



Set using ISO screws

STR-6200F

2410

General Export Model

USA Model 1st revision

Serial Number 801,351 and later

FM STEREO RECEIVER

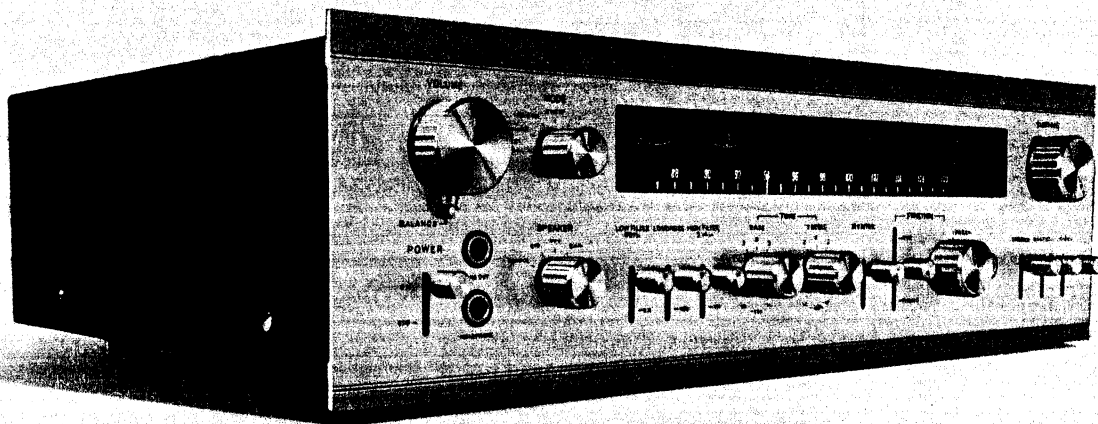

SONY®
SERVICE MANUAL

TABLE OF CONTENTS

	<i>Page</i>
SECTION 1 TECHNICAL DESCRIPTION	
1-1. Technical Specification	1
1-2. Detailed Circuit Analysis	2~12
LEVEL DIAGRAM	13
BLOCK DIAGRAM	
- Tuner Section -	14
- Audio Section -	15
SECTION 2 DISASSEMBLY AND REPLACEMENT PROCEDURES	
2-1. Tools Required	16
2-2. Hardware Identification Guide	16
2-3. Top Cover and Bottom Plate Removal	16
2-4. Front Panel Removal	16~17
2-5. Front Subchassis Removal	17
2-6. Dial-Cord Restringing	18~19
2-7. Mechanical Dial Calibration	20
2-8. Dial Scale Replacement	20
2-9. Pilot-Lamp Replacement	20
2-10. Meter Replacement	20
2-11. Control and Switch Replacement	20~21
2-12. Power Transistor Replacement	21
2-13. Rear Panel Removal	21
2-14. Replacement of Components Secured to The Rear Panel by Rivets	22
2-15. Chassis Layout	23
SECTION 3 ALIGNMENT AND ADJUSTMENT PROCEDURES	
3-1. Fm I-f Strip Alignment	24
3-2. Fm Discriminator Alignment	25
3-3. Fm Frequency Coverage Alignment	26
3-4. Fm Stereo Separation Adjustment	26~28
3-5. Muting Adjustment	28
3-6. Tuner Input-Meter Calibration	29
3-7. Tuning Meter Calibration	29~30
3-8. Power Supply Voltage Adjustment for Tuner Section	30
3-9. Power Amplifier Adjustment	30~31
SECTION 4 REPACKING	32
SECTION 5 DIAGRAMS	
Mounting Diagram	
- Balance/Volume/Loudness Control Board -	33
- Fm Front End -	34~35
- Fm I-f Board -	36~37
- Limiter Detector Board -	38~39
- MPX Board -	40~41
- Muting Board -	42~43
- Equalizer/Tone/Buffer Amplifier Board -	44~45
- Power Amplifier Board -	46~47
- Power Supply Board -	48~49
- Relay/Intermediary Board -	50
Schematic Diagram	
- Tuner Section -	51~52
- Audio Section -	53~54
SECTION 6 EXPLODED VIEW	55~58
SECTION 7 ELECTRICAL PARTS LIST	59~67

SECTION 1 TECHNICAL DESCRIPTION

1-1. TECHNICAL SPECIFICATIONS

Technical specifications for the STR-6200F are given in Table 1-1.

TABLE 1-1. TECHNICAL SPECIFICATIONS

Fm Tuner Section		
Antenna:	300 ohms balanced 75 ohms unbalanced	IM distortion: Less than 0.2% at continuous RMS power
Tuning range:	87.5 to 108 MHz	Frequency response: PHONO 1,2 : RIAA curve ± 0.5 dB TAPE : } 10 Hz to 100 kHz REC/PB : } ± 0 dB AUX 1,2,3 : } ± 3 dB
Sensitivity:	1.8 μ V (IHF usable sensitivity) 1.5 μ V (S/N, 30 dB) 1.2 μ V (S/N, 20 dB)	Input sensitivity and impedance: PHONO 1,2 : 1.4 mV, 47k TAPE : } REC/PB (input) : } 140 mV, 100k AUX 1,2,3 : }
S/N ratio:	70 dB	Signal output and impedance: REC OUT : 250 mV, 15k REC/PB out : 30 mV, 82k CENTER CHANNEL OUT; LINE OUT: 5V, 1k at 70W (8 Ω)
Capture ratio:	1.0 dB	S/N ratio: PHONO 1,2 : greater than 70 dB (weighting network "B")
Selectivity:	100 dB	TAPE : } greater than 90 dB REC/PB : } (weighting network "A") AUX 1,2,3 : }
Image rejection:	90 dB	Tone controls: BASS : ± 10 dB at 100 Hz (11 steps by 2 dB each) TREBLE: ± 10 dB at 10 kHz (11 steps by 2 dB each)
I-f rejection:	100 dB	Filters: HIGH: 12 dB/oct. above 9 kHz LOW : 12 dB/oct. below 50 Hz
Spurious rejection:	100 dB	Loudness control: +8 dB at 50 Hz +4.5 dB at 10 kHz (with 30 dB attenuation)
A-m suppression:	65 dB	Speaker equalizer: +6 dB at 50 Hz
Frequency response:	20 Hz to 15 kHz ± 0.5 dB	General
Stereo separation:	40 dB at 400 Hz	Power consumption: Approx. 180 watts (USA) Approx. 320 watts (Canada) Approx. 350 watts (General Export Model)
Harmonic distortion:	Mono: 0.2% IHF (400 Hz 100% Mod.) Stereo: 0.35% IHF (400 Hz 100% Mod.)	Power requirement: 117 volts only, 50/60 Hz ac (USA and Canada Model) 100, 117, 220, 240 volts, 50/60 Hz ac (General Export Model)
19 kHz, 38 kHz suppression:	70 dB	Dimensions: 483 mm (width) \times 145 mm (height) \times 405 mm (depth) 19" (width) \times 15 $\frac{11}{16}$ " (height) \times 15 $\frac{7}{8}$ " (depth)
SCA suppression:	65 dB	Net weight: 18.1 kg (39 lbs 15 ozs)
Muting level:	Less than 3 μ V	Shipping weight: 22.2 kg (49 lbs 4 ozs)
Audio Amplifier Section		
Dynamic power output:	360 watts (4 ohms), both channels operating	
(IHF constant power supply method)	245 watts (8 ohms), both channels operating	
Continuous RMS power:	90 watts (4 ohms) per channel, both channels operating 70 watts (8 ohms) per channel, both channel operating	
20 Hz to 20 kHz power:	60 watts (8 ohms) both channels operating	
Power band width:	10 Hz to 40 kHz, IHF	
Harmonic distortion:	Less than 0.2% at 1 kHz at continuous RMS power Less than 0.05% at 1 watt output	

* Design and specifications subject to change without notice.

1-2. DETAILED CIRCUIT ANALYSIS

The following describes the function or operation of all stages and controls. The text sequence follows signal paths. Stages are listed by transistor reference designation at the left margin; major components are also listed in a similar manner. Refer to the block diagram on page 14, 15 and the schematic diagram on page 51 to 54.

Stage/Control

Function

Front End Section

Balun B101	This is a transformer that matches either 75-ohm coaxial cable or 300-ohm twin lead to the tuner's input stage.
Rf amplifier Q101, Q105	The rf amplifier is designed to provide stable amplification, sharp selectivity at fm broadcast frequencies, and an optimum noise figure. Field-effect transistors are ideally suited for this job as they have characteristics similar to that of a triode and in addition have wide dynamic range. The latter characteristic results in very low cross-modulation products. The stage employs two FETs in a common-gate (similar to a grounded-grid circuit) configuration to compensate the tolerance of FET's operating characteristics. Triple-tuned coupling is employed between rf and mixer stages to provide sharp selectivity.
Local oscillator Q104	Supplies heterodyning voltage to the mixer via L105. The circuit is a modified Hartley type with feedback applied to the emitter from the tap on L105.
AFC circuit D101, D102 C126	An automatic frequency control circuit is incorporated in the oscillator circuit to eliminate frequency drift and the difficulty of precise tuning. The principle of afc operation is as follows: When the tuner is correctly tuned, the intermediate frequency is 10.7MHz and no dc correction voltage is produced by the ratio detector as shown in the "S" curve response of

Stage/Control

Function

Fig. 1-1. Thus the voltage applied to diode D101 is determined solely by the positive fixed reverse bias voltage supplied by zener diode D102. Now, assume that the local oscillator frequency changes by $+\Delta f$. This means that the new intermediate frequency is $10.7 + \Delta f$. See Fig. 1-1.

As the result a positive dc component is fed back to the anode of D101, decreasing the reverse voltage to it, and making D101's barrier capacitance increase. This decreases the local oscillator's frequency, since the series circuit composed of C126 and D101 is connected in parallel with the tank circuit of the local oscillator. Conversely, if the local oscillator frequency decreases a negative dc voltage is fed back to D101 increasing the local oscillator frequency.

Mixer Q102

Rf signals and local oscillator voltage are heterodyned in the base-emitter junction of mixer Q102 to produce 10.7MHz i-f output signal. IFT101 is a tuned transformer for 10.7MHz and its low impedance output winding supplies link coupling to the i-f preamplifier Q103.

I-f preamplifier Q103

The i-f signal coupled to the base of i-f preamplifier Q103 by the secondary winding of IFT101 is amplified to achieve a favorable signal-to-noise ratio before application to the filters in the i-f strip.

I-f Amplifier Section

I-f amplifiers Q201 to Q204

These i-f stages are basically RC coupled amplifiers that provide essentially flat response.

CF201 to CF208

The selectivity of this section is determined by the solid-state filters in the interstage coupling paths. These ceramic filters are made up of two individual sections that operate in a "trapped-energy" mode. The

<i>Stage/Control</i>	<i>Function</i>	<i>Stage/Control</i>	<i>Function</i>
	filters provide extremely sharp skirt selectivity and flat response inside the pass band. These filters determine overall selectivity in the tuner.		about 0.6 volts. Thus, the signal is limited in both directions to 1.2 volts peak-to-peak. The diodes provide symmetrical limiting.
TUNER INPUT meter M1	I-f signal from the collector of Q205 is coupled through C230 to rectifier D211. At this point in the circuit, the i-f signal is proportional to the rf signal strength for all but very-strong input signals. Therefore, the filtered dc output voltage of the rectifier is proportional to the rf signal strength, and is used to drive TUNER INPUT meter M1. R251 is provided to perform TUNER INPUT meter calibration.	I-f amplifier Q205	The diode limiters are passive devices and introduce loss. Therefore amplifiers, such as Q205 provide the additional gain needed to drive the limiters.
Diode limiters D201 to D208 D212, D213	Limiting is accomplished by these diode pairs, connected in parallel and poled in opposite directions. The diodes conduct when the voltage across them exceeds the barrier potential of	I-f buffer amplifier Q206	Q206 acts as a buffer amplifier supplying power to drive the muting circuit.
		Limiter-Detector Section	
		I-f amplifier Q301, Q302	These are conventional RC coupled amplifiers that supply the necessary interstage gain to drive the diode limiters (D301 to D304).
		I-f output Q303	Signal at the base of Q303 has had all amplitude variations removed by the preceding limiters, and only selected signals have been passed by ceramic filters.

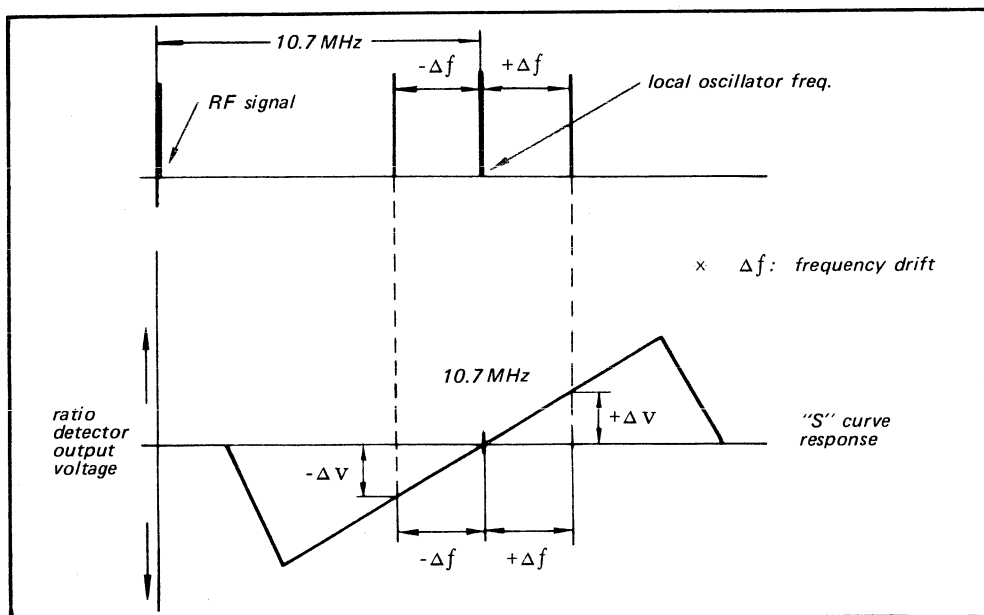

Fig. 1-1 Local oscillator frequency drift and afc voltage relationship

<i>Stage/Control</i>	<i>Function</i>
	Q303 provides power to drive the ratio detector.
Ratio detector D305, D306	IFT301 and diodes D305 and D306 form a balanced ratio detector that transforms the frequency-modulated signal into an audio signal. Output appears across C320.
TUNING meter M2	Center-zero meter assures correct tuning by utilizing the ratio detector's characteristic. As indicated in Fig. 1-1, no dc voltage is produced across connection of R320 and R321 and ground, when the tuner is correctly tuned. Deflection on the meter indicates the amount of deviation from the carrier frequency received. Note that the meter will indicate zero-reading when the tuner is not receiving any off-the-air signal.
R320, R321	
Emitter follower Q304	Q304 acts as a buffer amplifier between ratio detector and MPX decoder section. The emitter follower provides high input impedance and low output impedance.
SCA trap L303, C328	The composite signal containing monaural information from 0 to 15 kHz, the 19 kHz pilot carrier, and the fm stereo signal at 38 kHz, is fed to Q501 through trap L303~C328. This trap removes the unwanted SCA signals to feed a clean composite signal to the base of Q501 (the 19 kHz amplifier).
MPX Decoder Section	
19 kHz amplifier Q501	This stage serves two functions. It extracts the 19 kHz pilot signal by means of a tuned circuit at its drain, and provides a low-impedance source of composite stereo signal (without the pilot carrier) at its source. A series-resonant circuit in the emitter circuit eliminates the 19 kHz pilot signal in the composite stereo signal.
Frequency	Signals developed at the drain of

<i>Stage/Control</i>	<i>Function</i>
doubler MU501 D501, D502	Q501 are transformer coupled to a fullwave rectifier consisting of D501 and D502. The output of this rectifier is not filtered, resulting in two positive pulses for each input cycle. Thus, the 19 kHz pilot-carrier frequency is effectively doubled by D501 and D502. However, the waveform is not sinusoidal at the base of Q502.
38 kHz amplifier Q502	The 38 kHz pulses produced by D501 and D502 are amplified by Q502. The tank circuit at the collector of Q502 is tuned to 38 kHz to restore these pulses to a sinusoidal waveform. This signal is transformer coupled to the bridge-type demodulator to supply sampling drive for the demodulator.
STEREO lamp circuit Q503	The STEREO indicator lights when the FUNCTION switch is set to the FM AUTO STEREO or ST ONLY position and an fm stereo signal is received. The emitter of Q502 is connected to the base of Q503 (which is normally cut off). The circuit operates as follows: When a composite stereo signal is applied to the multiplex decoder, the 38 kHz pulses produced at the output of the frequency doubler yield a higher average current flow through Q503. This forces Q503 into conduction, lighting STEREO indicator lamp PL501.
Multiplex demodulator T501 D505, D506, D507, D508	The demodulator circuit employs four diodes in a balanced-bridge arrangement. This system has the advantage of cancelling residual rf components (38 kHz signal, some 19 kHz signal, and higher-order harmonics of these frequencies.) "L" and "R" components are developed at each side of the bridge as the result of demodulation (see Fig. 1-2), when the receiver is operated in the stereo mode. In the monaural mode,

<i>Stage/Control</i>	<i>Function</i>
	diodes D505 and D508 are forward biased by supply voltage through R505, the stereo indicator lamp, R512, R514 and R513, so these diodes merely act as small resistances. Under this condition, the monaural signal is applied to both "L" and "R" audio amplifiers.
De-emphasis capacitors and changeover switch C522, C523, C524, C525, C526, C527 S16	These capacitors provide the roll off at high audio frequencies necessary to compensate for pre-emphasis at the transmitter. S16 should be set to the proper time constant. Specified de-emphasis time constant is 75 micro-seconds in USA and CANADA, 50 micro-seconds in Europe.
HIGH BLEND switch S15	The HIGH BLEND switch allows the mixing of high frequency

<i>Stage/Control</i>	<i>Function</i>
Audio pre-amplifier Q504, Q506, Q505, Q507	audio signals between stereo channels. When placed in the IN position the switch operates to reduce the noise of demodulated stereo signal.
Separation control R547	Demodulated L and R signals are amplified by these stages to the level required at the input of the following low pass filter.
Low-pass filter LPF501	The network that connects the emitters of Q504 and Q505 provides a form of negative feedback between left and right channels. Any residual L signal in the R channel (which is about 180° out of phase) is cancelled out by the L signal from the L channel. The same is true of residual R signal in the L channel. R547 is therefore set for maximum separation.
	The filter removes all residual subcarrier components. It is important that these components be removed completely to prevent beat interference with bias oscillators in tape recorders fed from the tuner.

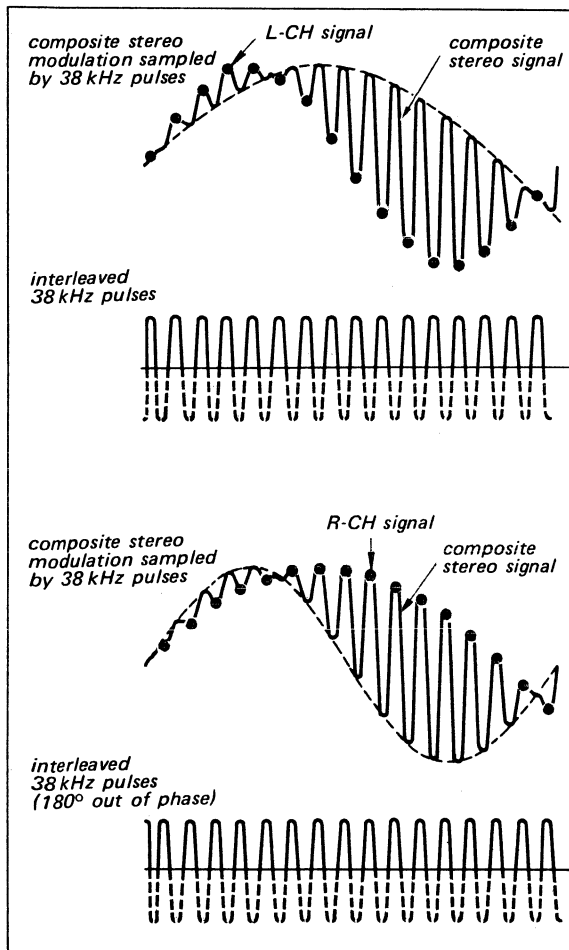

Fig. 1-2 Stereo demodulation operation

Muting Circuit Section

These circuits act to mute output when tuning is between stations or not sufficiently tuned to the center of a channel. They also work as one of the elements of FM MODE switch circuit.

Interstation muting Q409 D401, D402	The hiss and static of interstation noise are extracted from the emitter of Q304 and applied to the base of Q409. R420 and C402 in the coupling circuit filter out audio components so that the signal is primarily noise. Q409 amplifies the noise component and drives the voltage doubler, D401 and D402. When interstation noise is received the dc output of D401 and D402 brings Q406 into conduction.
Muting relay actuator Q408	This in turn, cuts off Q407 and the collector voltage of Q407 rises toward +B. The col-

Stage/Control

Function

lector of Q407 is coupled to the base of Q408. Thus, Q408 turns on as Q407 turns off. As the muting relay coil is in the collector circuit of Q408, the audio output of both channels is shorted to ground while the interstation noise appears at the ratio detector's output.

D403

D403 has the effect of controlling the sensitivity of noise amplifier Q409 to obtain a proper muting operation. That is, the sensitivity of Q409 increases when either Q405 or Q406 is "ON", shorting the emitter circuit of Q409 to ground through D403. However, it decreases when the receiver is tuned correctly, disconnecting the emitter bypass circuit D403 and Q405 and Q406. Thus, it prevents intermittent operation of the muting system.

Muting for the detuned condition Q401 to Q405

The muting relay is also actuated if a station is being received but there is a considerable tuning error. This muting circuit operates from the negative or positive output of the ratio detector when the received station is not at the center of the detector's "S" curve (see Fig. 1-3). Dc output from the ratio detector, developed across C320, is coupled to the gate of Q401. The operation of the related switching transistors is shown in Table 1-1.

Stage/Control

Function

Note that Q405 and Q406 share a common load and act as OR gate. If either Q405 or Q406 is ON, the muting relay will be energized.

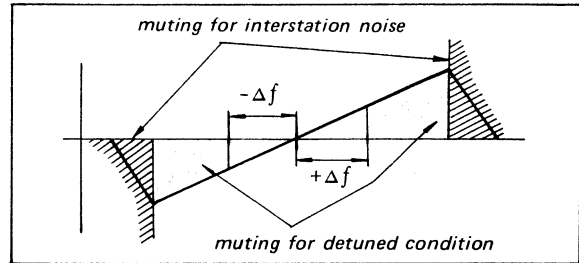

Fig. 1-3 Muting operation diagram

Muting for low level signals Q206, Q410 D209, D210

In addition to interstation and detuned-condition muting, the muting relay is also actuated if the signal level is below the value specified. This system operates as follows:

I-f signal from the collector of Q204 is coupled through C225 to a buffer amplifier Q206 and then fed to the rectifier-doubler consisting of diodes D209 and D210. At this point in the circuit, the i-f signal is proportional to the rf signal strength for all but very-strong input signals. Therefore, the filtered dc output voltage of the rectifier-doubler is proportional to the rf signal strength, and is used to drive the switching transistor Q410.

Q410 is cut off when input rf signal level is low, forcing Q405 into conduction, thus the muting relay is energized. When input rf signal level increases Q410

TABLE 1-1

Condition	Q402	Q403	Q404	Q405	Q407	Q408	Relay
Detuned to + Δf	OFF	OFF	OFF	ON	OFF	ON	short
Tuned correctly	ON	OFF	ON	OFF	ON	OFF	open
Detuned to - Δf	ON	ON	OFF	ON	OFF	ON	short

<i>Stage/Control</i>	<i>Function</i>
	turns ON and has no effect upon Q405's operation due to D404 in the coupling circuit between Q410 and Q405.
D405	D405 has the effect of controlling the sensitivity of i-f buffer amplifier Q206 to obtain a stable muting operation. That is, the sensitivity of Q206 increases when Q410 conducts, shorting the emitter circuit of Q206 to ground through D405 and R431 but it decreases when Q410 is cut off disconnecting the emitter by-pass circuit D405 and R431. Thus, it prevents the intermittent operation of the switching system.
MUTING switch S13	The muting system is disabled when the muting switch is set to OUT position. In this case a positive voltage is applied to the base of Q407 through R418. This turns on Q407 and keeps Q408 off. As the result the muting relay REL-1 is kept open.
Muting in the FM ST ONLY mode	The FM MODE switch has no effect upon the switching circuit in the FM AUTO ST position. When the FM MODE switch is in the ST ONLY position, Q408 is controlled by Q503. The latter is ON when 19 kHz pilot signal is detected in the frequency doubler circuit. When Q503 is ON, Q408 turns off opening the muting relay. If the output level of the frequency doubler should drop so that Q503 turns off, Q408 will conduct and mute the MPX decoder's output. Thus the tuner is muted except when a stereo signal is received.
Q411	This operates as a switching circuit which determines the operation of MPX decoder according to the position of MODE switch S4. Q411 operates only when MODE switch S4 is set to L+R position and stereo signal is received. In the L+R

<i>Stage/Control</i>	<i>Function</i>
	position, the output of frequency doubler is fed to the base of Q411 through S4 and D407. This drives Q411 into conduction. As the result, the frequency doubler's output is shorted to ground through R508, S4, D407 and the base-emitter circuit of Q411, preventing the STEREO lamp from lighting.
FM MODE switch S14	On the other hand, when FM MODE switch S14 is in the ST ONLY position and S4 is in the L+R position, Q408 is controlled by Q411 instead of Q503 as the base circuit of Q408 is connected to the collector of Q411 through S4 and S14. Note that the tuner is muted except when a stereo signal is received but the output obtained is monaural and the STEREO lamp will not light by means of MODE switch S4 and Q411.

Preamplifier Section

Equalizer amplifier Q601, Q602, Q603	This direct-coupled three stage amplifier amplifies the small signal provided by the phono cartridge to the level required at the input of the following tone-control amplifier.
Bias circuit	Dc bias voltage for Q601 is extracted from R613 in the emitter circuit of Q603 and fed back to the base of Q601 through R604 and R605. This dc negative feedback technique provides stable operation during temperature changes.
Equalization circuit	RIAA equalization is achieved by the negative-feedback loop containing R614, R615, R616, R606, C608 and C609. Be sure to use replacement components with the exact same values.
Equalization circuit	R619(8.2k) in the output circuit prevents interaction between left and right channel equalization when the MODE switch is set to L+R.

<i>Stage/Control</i>	<i>Function</i>	<i>Stage/Control</i>	<i>Function</i>
MODE switch S4	Selects the desired mode of operation. This switch may also be used for test purposes. The relation between the positions of the MODE switch and the outputs of the set are summarized in the table below.		negative-feedback type tone-control circuit. The output generated at the collector circuit of Q605 is fed back to the emitter circuit of Q604 through the treble and bass tone-control network.
MONITOR switch S3	Selects the signals from TAPE, AUX or equalizer output.	TREBLE control S6	Increase or decreases the amount of negative feedback voltage determined by the setting of S6. It has a range of ± 10 dB at 10 kHz.
VOLUME control RV602	The equalized phono signals and signals applied to the other input terminals are fed to the VOLUME control through the MONITOR and MODE switches. The level of the signal applied to the following tone-control amplifier is determined by the setting of RV602.	BASS control S7	Similar to the treble control except for filter components and frequency characteristics. This control has a range of ± 10 dB at 100 Hz.
LOUDNESS switch S5	This switch and R621, R622, C610, C611 compensate for the characteristics of the human ear which vary according to the loudness of the sound being heard. When this switch is set to ON and the VOLUME control is set for 30 dB attenuation, the overall frequency response is increased +8 dB at 50 Hz and +4.5 dB at 10 kHz with reference to the level at 1 kHz.	HIGH FILTER switch S8	Eliminates unwanted high-frequency components from the input signal (12 dB/oct above 9 kHz) in the IN position.
Tone-control amplifier Q604, Q605	This direct-coupled two-stage amplifier has basically flat response, but it operates as a	Emitter follower Q606	Q606 acts as a buffer amplifier between the high and low filters. The emitter follower provides high input impedance and low output impedance.
		LOW FILTER switch S9	High-pass filter cuts out unwanted low frequency components from the input signal. These unwanted low frequencies include rumble created by the turntable, record changer, or the

TABLE 1-2

RECEIVER OUTPUTS MODE SELECTOR SWITCH POSITION	SPEAKER OUT; LEFT	SPEAKER OUT; RIGHT	CENTER CHANNEL OUT	HEADPHONE OUT; LEFT	HEADPHONE OUT; RIGHT	LINE OUT; LEFT	LINE OUT; RIGHT	REC OUT; LEFT	REC OUT; RIGHT
CHECK L	L+R		L+R	L+R		L+R		L+R (L)	L+R (R)
CHECK R		L+R	L+R		L+R		L+R	L+R (L)	L+R (R)
REVERSE	R	L	L+R	R	L	R	L	L	R
STEREO	L	R	L+R	L	R	L	R	L	R
L+R	L+R	L+R	L+R	L+R	L+R	L+R	L+R	L+R	L+R
LEFT	L	L	L	L	L	L	L	L	R
RIGHT	R	R	R	R	R	R	R	L	R

Note: When the MONITOR switch is set to the TAPE, the REC OUT outputs provide the signals shown in parenthesis.

Stage/Control *Function*

record itself. This eliminates the low-frequency components from the input signal (12 dB/oct below 50 Hz) when the low filter switch is set to the ON position.

Power Amplifier Section

Preamplifier
Q801, Q802 Q801 and Q802 form a para-phase amplifier but signal output is extracted from the collector circuit of Q801. This circuit has various advantages in direct coupling systems. One is high stability despite temperature variations and another is high input impedance without reducing the amplifier's gain. The ac output appears across load resistor R806 (1.5k) in the collector circuit. An emitter decoupling circuit is formed by the emitter-base resistance of Q802, C803 and R809 in the base circuit of Q802.

An emitter circuit formed by the emitter-base resistance of Q802, C803 and R809 is essentially a frequency-selective ac by-pass to reduce the amplifier's gain at very low frequencies. Common emitter-resistor R805 keeps the dc current flow constant in Q801 and Q802, thus increasing the dc stability.

Dc balance adj.
RV801 The stabilized positive and negative power supply voltage are picked off by R844, D811, R846 and D810, and applied to RV801 or RV901. RV801 provides a stabilized bias voltage for transistor Q801 to set the output terminal voltage at zero dc.

SPEAKER EQUALIZER switch
S10 This switch changes the power amplifier's frequency response when it is set to the ON position compensating for insufficient bass response in some speaker systems. That is performed by decreasing the amount of negative feedback voltage at low frequencies determined by the

Stage/Control *Function*

series circuit consisting of R808 and C805.

Thermal compensation and noise suppressor
D801 As all the stages are directly coupled, dc stability is required. The negative temperature coefficient of D801 provides thermal compensation for the following driver stage. It also acts as a noise suppressor to reduce the popping noise due to unbalanced current flow in the following stages when the power switch is turned off.

Driver Q804 Though this stage is a conventional flat amplifier, it determines the output voltage swings because the following stages are basically emitter-followers. The ac load resistor for this stage is R814 (3.9k).

Dc bias adj.
(idling current)
Q803, RV802 Q803 is biased into conduction and operates as a small resistance providing the necessary forward bias on the two cascaded emitter-followers. RV802 controls the base bias of Q803, determining its emitter-collector impedance and thereby controls the dc bias voltage for the following complementary circuit.

Thermal compensator for dc bias
D802 The negative temperature coefficient of diode D802 provides thermal compensation for the complementary and power transistor circuits. D802 is attached to the power transistor's heat sink to detect temperature increases in the power transistors.

Complementary circuit
Q808, Q809 These transistors operate as emitter-followers to provide the current swings demanded at the output stages and also provide the necessary phase inversion. Phase inversion is performed by using PNP and NPN type transistors.

Power transistor
Q810, Q811 The output transistors Q810 and Q811 are connected directly to a power supply of about $\pm 51V$.

Stage/Control

Function

Q810 supplies power to the load during the positive half cycle and Q811 operates during the negative half cycle. As all the stages are directly coupled and designed to obtain zero potential at the output terminal, the large coupling capacitor at the output which may cause power loss or distortion at low frequencies is eliminated.

Protection circuit

Two kinds of protection circuits are employed in this power amplifier. One is a power transistor protection circuit and the other is a speaker system protection circuit.

Power transistor protection circuit

To protect overloaded power transistors from destruction, a new protection circuit is employed. In the event of a short circuit at the output terminals, the protection circuit holds down the current in the power transistor so as not to make it overheat and also limit the input drive signals. Fig. 1-4 shows a partial schematic diagram detailing the protection circuit. With reference to this diagram, the protection circuit operates as follows:

(Since the protection circuit is identical for positive-going half cycles and negative-going half

Stage/Control

Function

cycles, only the positive-going half cycle operation is described here.)

Q807 limits the positive-going half cycle of the drive voltage applied to the base of Q808 when power consumption at the Q810 collector exceeds the safety margin. Since power dissipation at the collector can be considered a function of collector voltage (B+ voltage) and current which flows in the power transistor, the trigger signal for Q807 is taken from the B+ line and emitter of Q810. Base voltage is partly determined by the ratio of resistance of R819 and series resistance of R828, R836 and RL (load). Base voltage is also determined by the current flow in the R836 and the collector voltage of Q810.

During normal operation, Q807 is cutoff. When excessive current flows in the power transistor or power dissipation at the collector of the power transistor exceeds the specified value, Q807 turns on and limit the input drive voltage to the power transistor. Limiting operation is also actuated by the condition of the load. The base voltage of Q807 is determined by the resistances R821, R823, R828, R836 and RL (load).

D807 prevents reverse voltage from being applied during the negative-going half cycle. Q807 turns on limiting the input drive voltage to the power transistor when the load resistance decreases to some extent. Under reactive load conditions in class B amplifiers, maximum current will flow when the voltage across the power transistor is maximum and this is the worst case for secondary breakdown. See Fig. 1-5. Since all speakers have reactive properties, the protection circuit must take care of this problem.

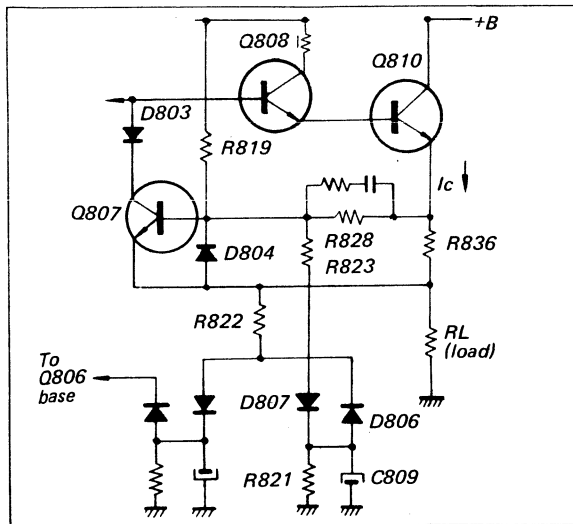

Fig. 1-4 Simplified protection circuit

Stage/Control

Function

Fig. 1-5 shows the operating load lines for one half of a class B output stage under conditions of equal load impedance; in one case the load is purely reactive, a load case would result in transistor failure. Through a complex network of resistors and transistors, D806, C809 and R821 change the base voltage of Q807 according to the reactive voltage induced in the load to provide proper protection. Diode D806 detects reactive voltage at the output terminal and charges C809. This voltage changes the bias on Q807 to compensate for the reactive voltage. D804 protects Q807 from breakdown between base and emitter due to detected reactive voltage across C809.

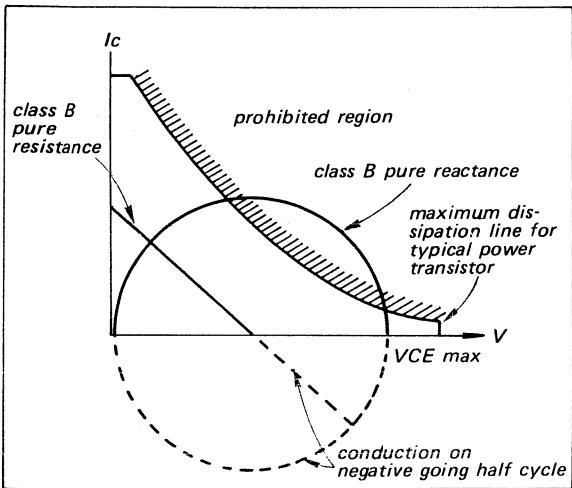

Fig. 1-5 Resistive and reactive load lines for class B output stage showing breakdown risk in purely resistive load

Speaker protection circuit

In a direct-coupled power amplifier, some faults in the prior transistor appears as a large unbalanced dc voltage across output terminal. This might damage a delicate speaker system. Therefore, the STR-6200F incorporates speaker protection circuit which operates as follows (refer to Fig. 1-6):
The output signal is extracted from the output terminal

Stage/Control

Function

through a low-pass filter (R23 or R24, C27 and C28) and fed to the bridge rectifier (D7, D8, D9 and D10). Because of this filter, the voltage applied to the bridge rectifier is only the very-low frequency or dc component caused by transistor faults. When the rectified dc voltage becomes large enough, it starts the Hartley oscillator (Q9 and T2). The oscillator's output is rectified by D11 and thus provides trigger voltage for SCR D16. When the trigger voltage is applied to the gate of SCR, the SCR turns on and shorts the base voltage of Q809 to ground through D15, the SCR, and D13. The base voltage of Q808 is also shorted to ground through D12, the SCR, and D14, stopping any current flow in the output stage and thus protecting the speaker system.
Note that the direction of diodes D15, SCR D16 and D12 which also ensure the speaker protection operation even if one of the power transistors is damaged by accident, forcing the other power transistor into secondary breakdown.

Power supply D5

A full-wave bridge rectifier (D5) and center-tapped transformer provide positive and negative

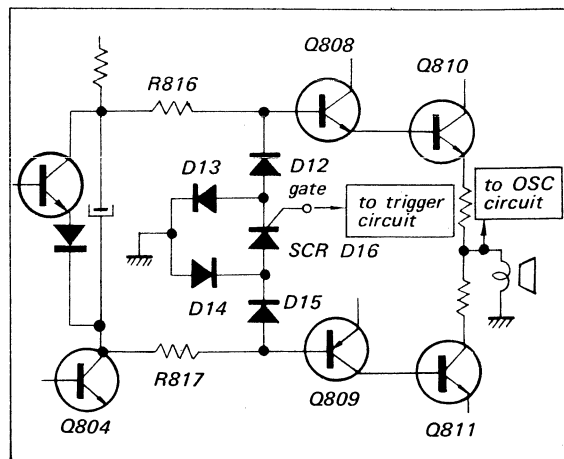
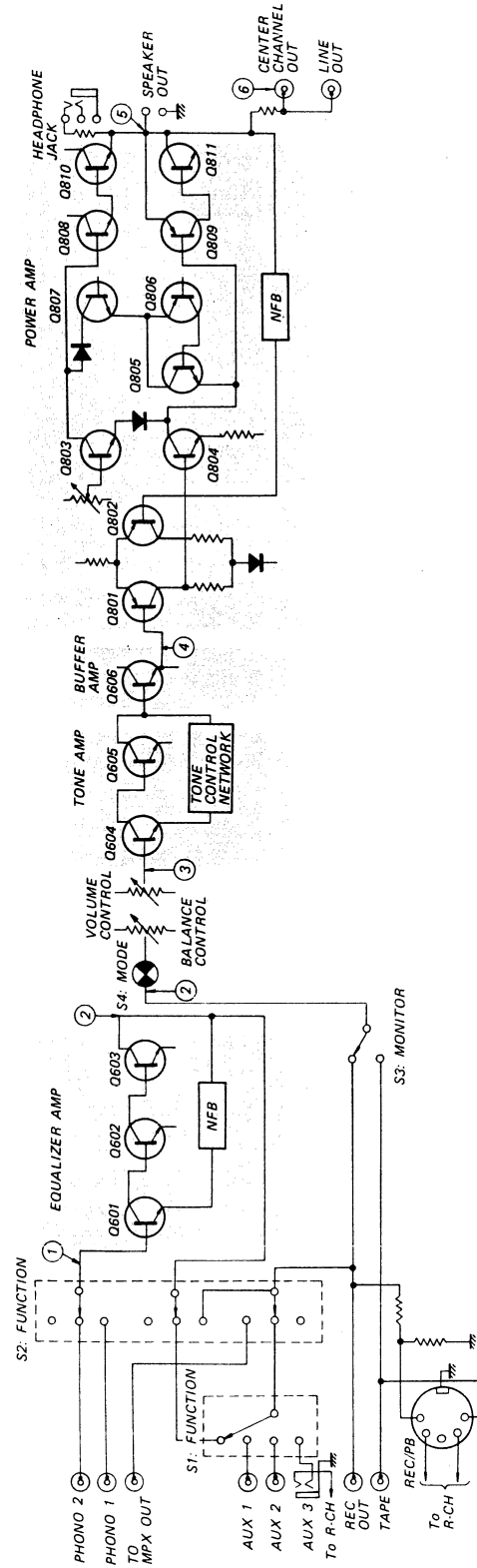
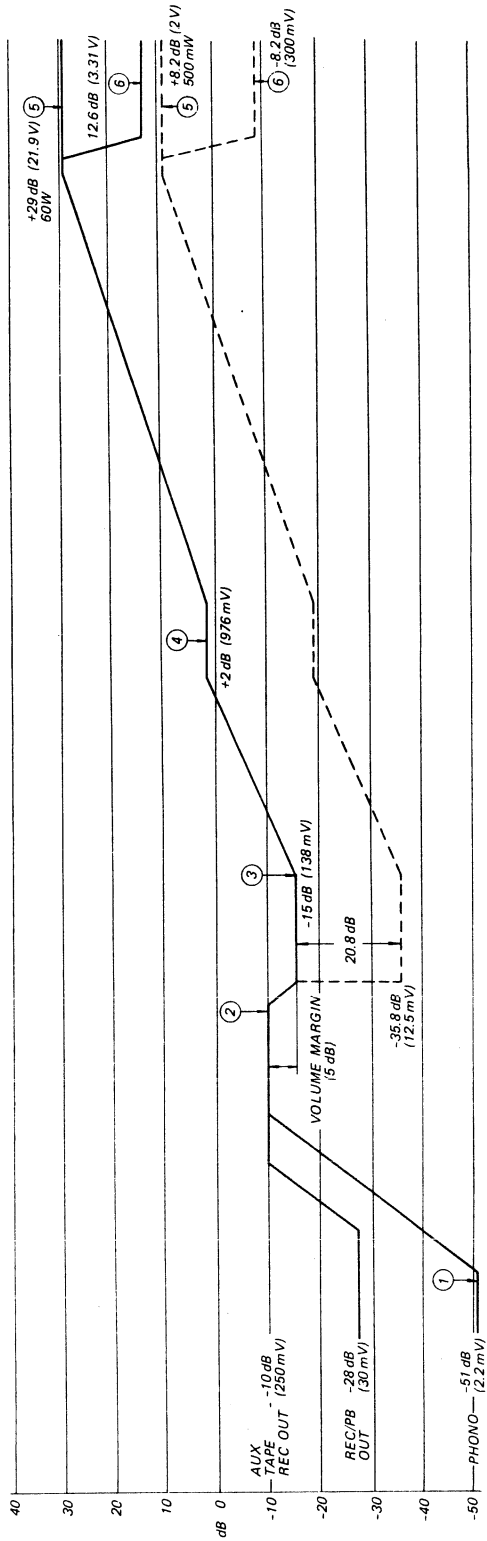

Fig. 1-6 Speaker protection circuit

<i>Stage/Control</i>	<i>Function</i>	<i>Stage/Control</i>	<i>Function</i>
	dc power supplies for the power amplifier.		RV1 with reference voltage supplied by voltage regulator Q1. A change in output voltage is detected at the base of Q3 and therefore alters the collector voltage. Since the collector of Q3 is directly coupled to the base of Q2, the change in output voltage alters the conduction of Q2 by the amount necessary to maintain the output voltage constant. An increase in output voltage causes an increase in the impedance (decrease in conduction) of Q2, and vice versa. The dc output voltage supplied to the tuner section is therefore extremely stable.
Rectifier D4, D6	A pair of half-wave rectifiers (D4 and D6) and filter capacitors (C17 and C14) supply additional dc power upon bridge-rectifier output for complementary stages.		
Ripple filter Q4, Q5	These components reduce the ripple voltages in the dc power supply for preamplifier and driver stages of the power amplifier section to an extremely-low value. Q4 and Q5 serve as an electronic filter to supply well filtered dc of about $\pm 55V$ to each stage.		
Voltage regulator Q1	Dc output from rectifier D21 and D22 is filtered by C3 and applied to series regulator Q1 to supply a well filtered 15V to the tuner section. Zener diodes D2 and D3, and capacitor C4 keep the base voltage of Q1 constant, so the emitter voltage of Q1 remains constant regardless of load or line voltage variations.	Muting circuit/ ripple filter Q6, Q7, Q8	This muting circuit prevents a loud "popping" noise due to initial current flow to the pre-amplifier stages that might damage a delicate high-fidelity speaker system. The muting is performed by bringing Q8(ripple filter) into conduction gradually by means of an associated switching circuit (Q6 and Q7) which has the proper time lag. The time lag is determined by the time constant of capacitor C24 and resistor R20 in the base circuit of Q6.
Voltage regulator Q2, Q3	Dc output from rectifier D1 is filtered by C3 and applied to series regulator Q2. Q3 compares a sample of the output voltage picked off across		

LEVEL DIAGRAM



STR-6200F

BLOCK DIAGRAM - Tuner Section -

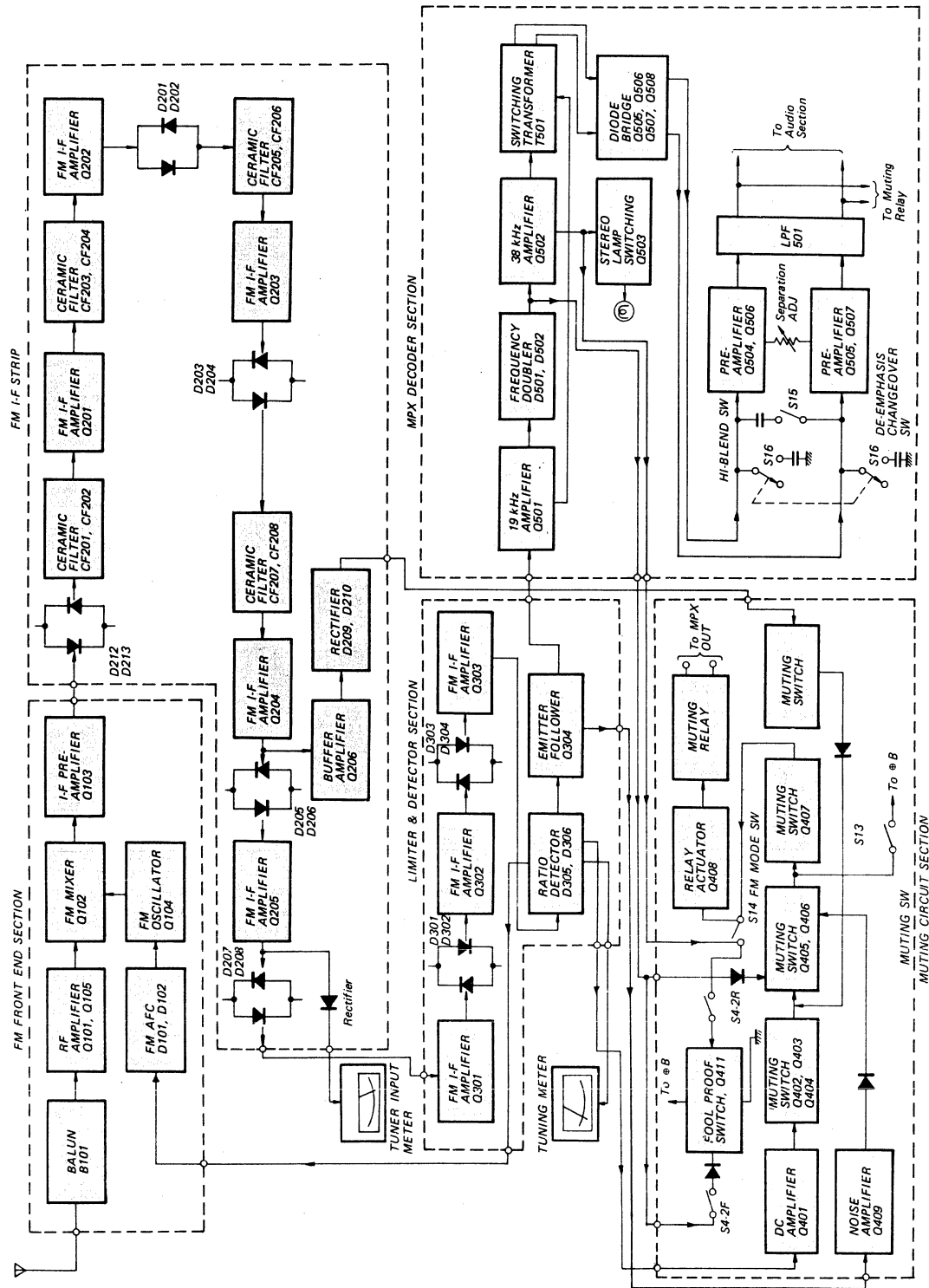

BLOCK DIAGRAM — Audio Section —

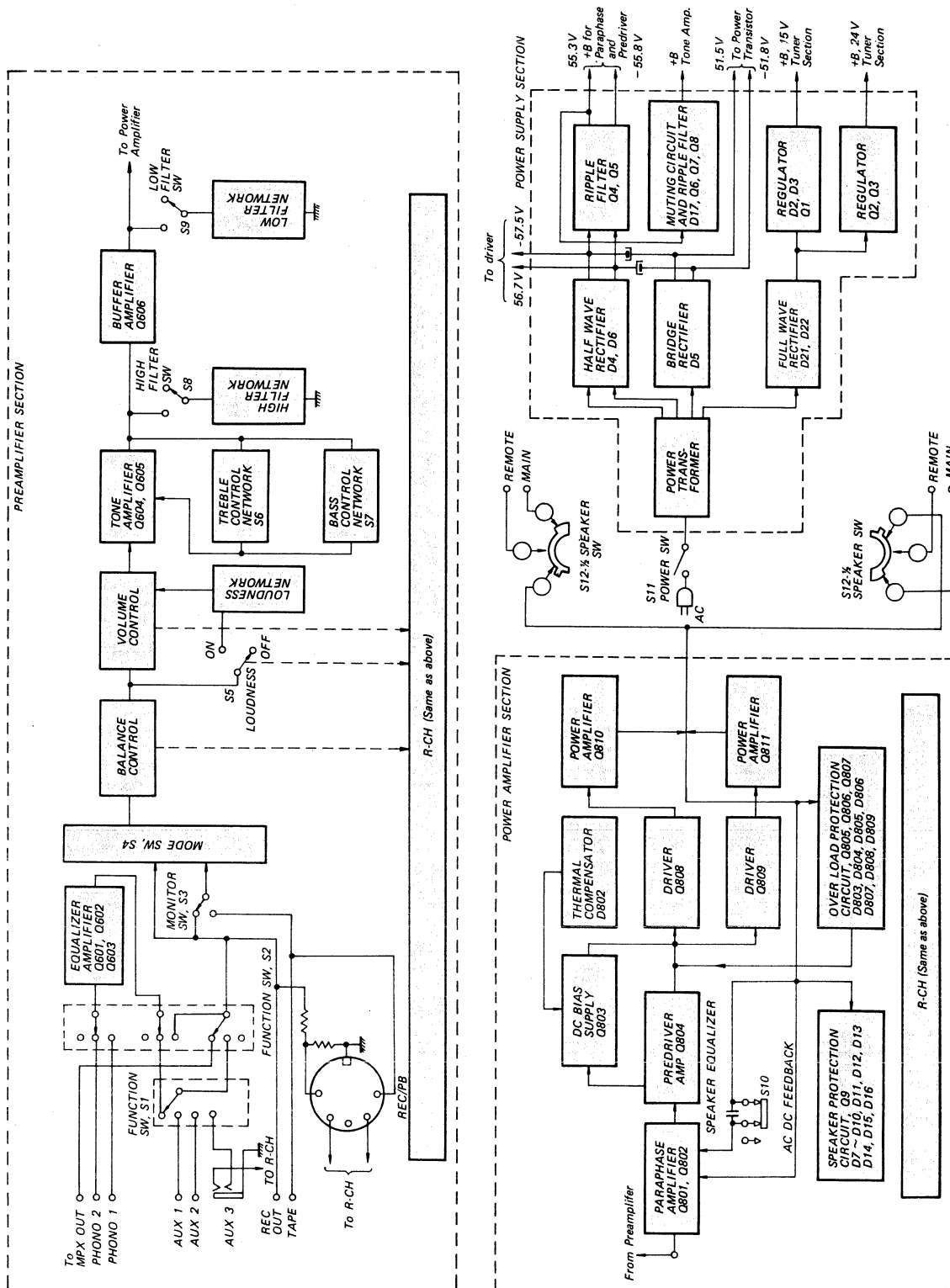

SECTION 2 DISASSEMBLY AND REPLACEMENT PROCEDURES

WARNING

Unplug the ac power cord before starting any disassembly or replacement procedures.

2-1. TOOLS REQUIRED

The following tools are required to perform disassembly and replacement procedures on the STR-6200F.

1. Screwdriver, Phillips-head
2. Screwdriver, 3 mm (1/8") blade
3. Pliers, long-nose
4. Diagonal cutters
5. Wrench, adjustable
6. Tweezers
7. Electric drill
8. Drill bits
9. Prick punch
10. Hammer, ball-peen
11. Soldering iron, 40 to 50 watts
12. Solder, rosin core
13. Cement solvent
14. Cement, contact
15. Silicone grease

2-2. HARDWARE IDENTIFICATION GUIDE

The following chart will help you to decipher the hardware codes given in this service manual.

Note: All screws in the STR-6200F are manufactured to the specifications of the International Organization for Standardization (ISO). This means that the new and old screws are not interchangeable because ISO screws have a different number of threads per mm compared to the old ones. The ISO screws have an identification mark on their heads as shown in Fig. 2-1.

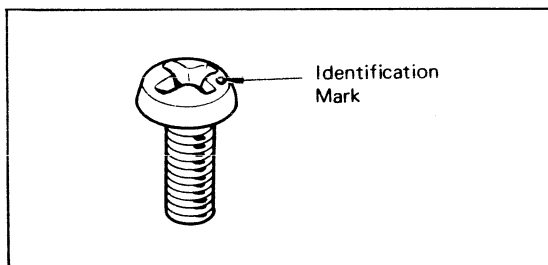

Fig. 2-1 ISO screw

Hardware Nomenclature

P	- Pan Head Screw		
PS	- Pan Head Screw with Spring Washer		
K	- Flat Countersunk Head Screw		
B	- Binding Head Screw		
RK	- Oval Countersunk Head Screw		
T	- Truss Head Screw		
R	- Round Head Screw		
F	- Flat Fillister Head Screw		
SC	- Set Screw		
E	- Retaining Ring (E Washer)		
	W	- Washer	
	SW	- Spring Washer	
	LW	- Lock Washer	
	N	- Nut	

- Example -

- Type of Slot: P
- Length in mm (L): 3
- Diameter in mm (D): 10
- Type of Head: 10

2-3. TOP COVER AND BOTTOM PLATE REMOVAL

1. Remove the two machine screws at each side of the receiver, and lift off the top cover.
2. Remove the ten self-tapping screws (\oplus B 3x6) at the bottom of the receiver (see Fig. 2-2) and pull the bottom plate in the direction indicated by the arrow in Fig. 2-2.

2-4. FRONT PANEL REMOVAL

1. Remove the top cover as described in Procedure 2-3.
2. Remove all control knobs and levers. The knobs can be removed by loosening the slotted set screws and pulling the knobs straight out. Note that the FUNCTION switch knob have two set screws. The levers are simply pulled off.

3. Remove the four screws (\oplus PS 4x6) behind the top edge of the front subchassis as shown in Fig. 2-4.
4. Remove the four self-tapping screws (\oplus B 3x6) at the front bottom of the chassis as shown in Fig. 2-2. This frees the front panel.

2-5. FRONT SUBCHASSIS REMOVAL

The front subchassis is the vertical member on which the dial scale, tuning meters and pilot lamps are attached. The front subchassis must be removed to re-string the dial cord.

1. Remove the top cover and front panel as described in Procedures 2-3 and 2-4.
2. Remove the two self-tapping screws (\oplus B 3x6) at each side of the chassis (see Fig. 2-4) and one screw (\oplus B 3x6) securing the terminal strip to the chassis as shown in Fig. 2-3.
3. Unsolder the lead wires from the dial lamp socket as shown in Fig. 2-3.
4. Take out the stereo lamp.
5. Referring to Fig. 2-5, remove the controls or bracket as given in the list below.

- VOLUME/BALANCE control
- MODE switch bracket
- POWER switch
- FM MODE switch
- HIGH BLEND switch

This frees the front subchassis as shown in Fig. 2-6.

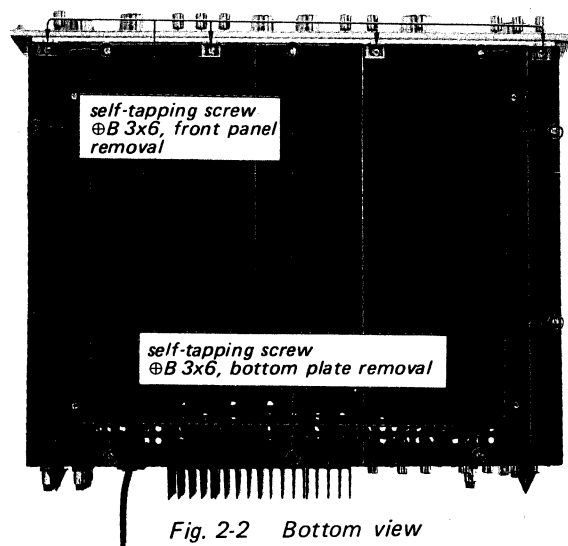

Fig. 2-2 Bottom view

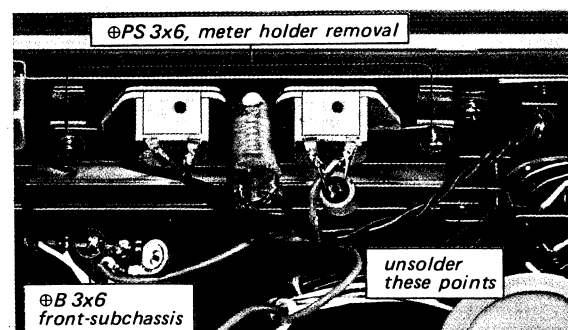

Fig. 2-3 Front subchassis removal

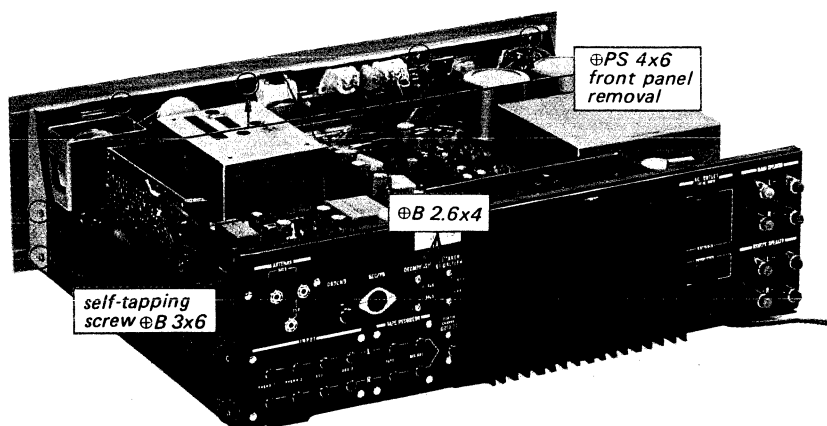

Fig. 2-4 Rear view

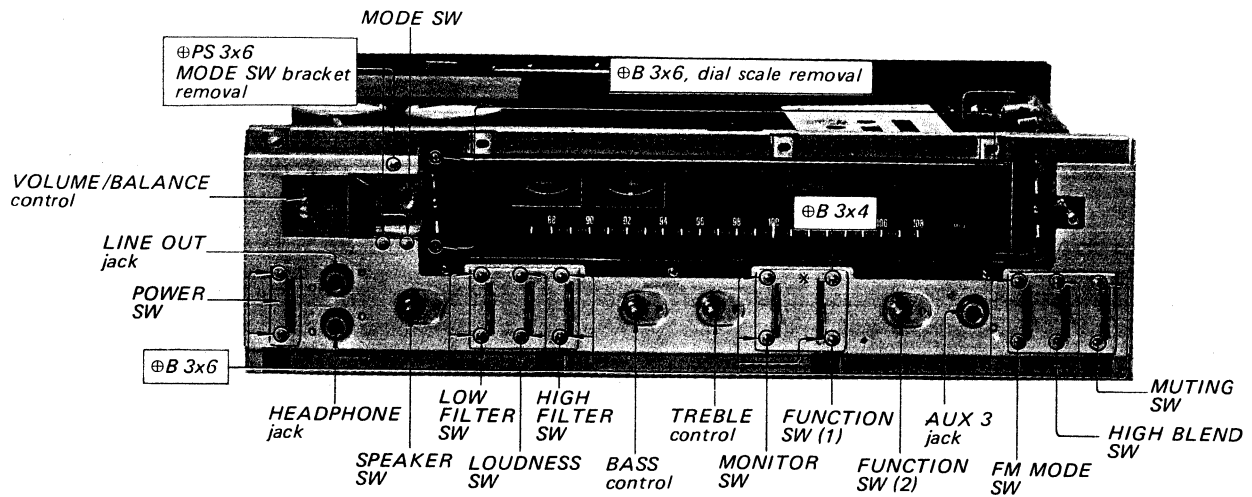

Fig. 2-5 Control and switch replacement

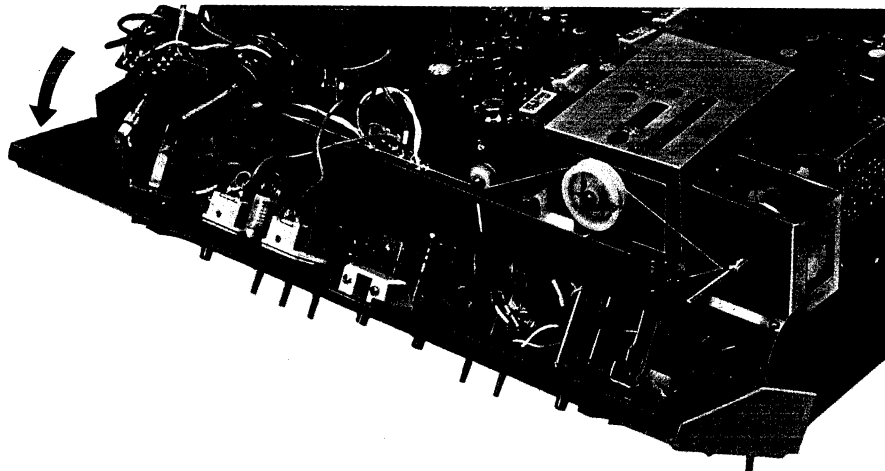

Fig. 2-6 Front subchassis removal

2-6. DIAL-CORD RESTRINGING

Preparation

1. Remove the front subchassis as described in Procedure 2-5.
2. Cut a 1,500 mm (59") length of dial cord.
3. Tie the end of the cord to a spring as shown in Fig. 2-7.
4. Rotate the tuning-capacitor drive drum fully counterclockwise (minimum capacitance position).

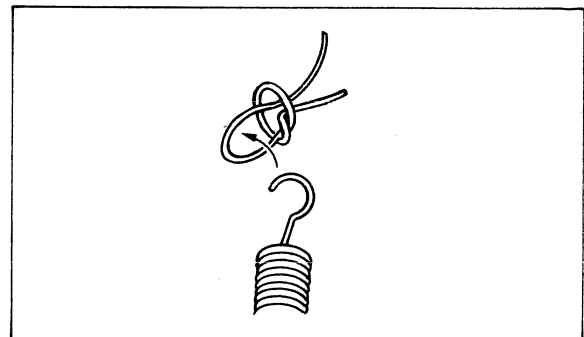

Fig. 2-7 Tying square knot to the coil spring

Procedure

While referring to Fig. 2-9, proceed as follows:

1. Hook the spring to one hole of the drive drum as shown in Fig. 2-8.
2. Run the cord through the slot in the rim of the drum and wrap a half counterclockwise turn in the inner groove. See Fig. 2-10.
3. Run the cord over pulley "A", "B" and "C" and, then wrap two and half clockwise turns around tuning shaft.
4. Wrap two and half counterclockwise turns around the drum from outer groove to inner

groove as shown in Fig. 2-10.

5. Pass the doubled end of the cord through the eyelet, then hook it to the spring as shown in Fig. 2-11.
6. Tighten the cord, then squeeze the eyelet so that the spring is under tension. Make a knot in the cord end to keep it from slipping out of the eyelet.
7. After completing the dial-cord stringing, make sure that the tuning system works properly. Apply a drop of contact cement to the finish point.

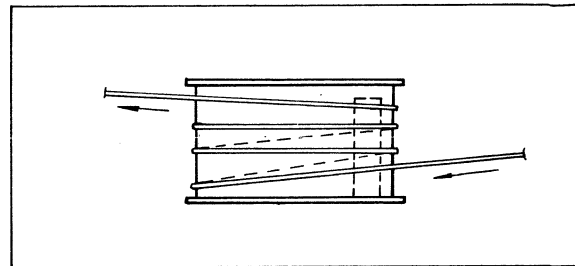

Fig. 2-10 Wrapping the dial cord

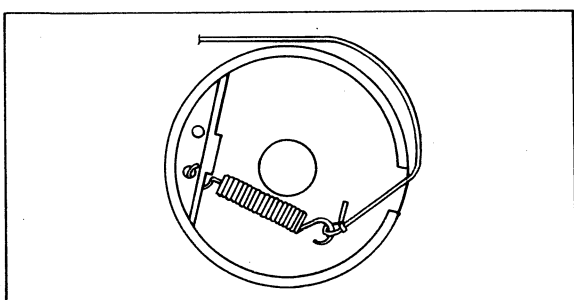

Fig. 2-8 Coil spring installation

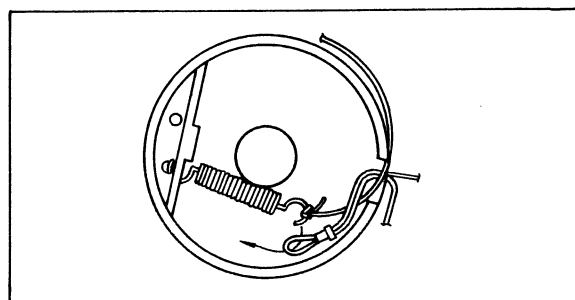

Fig. 2-11 Finishing dial cord stringing

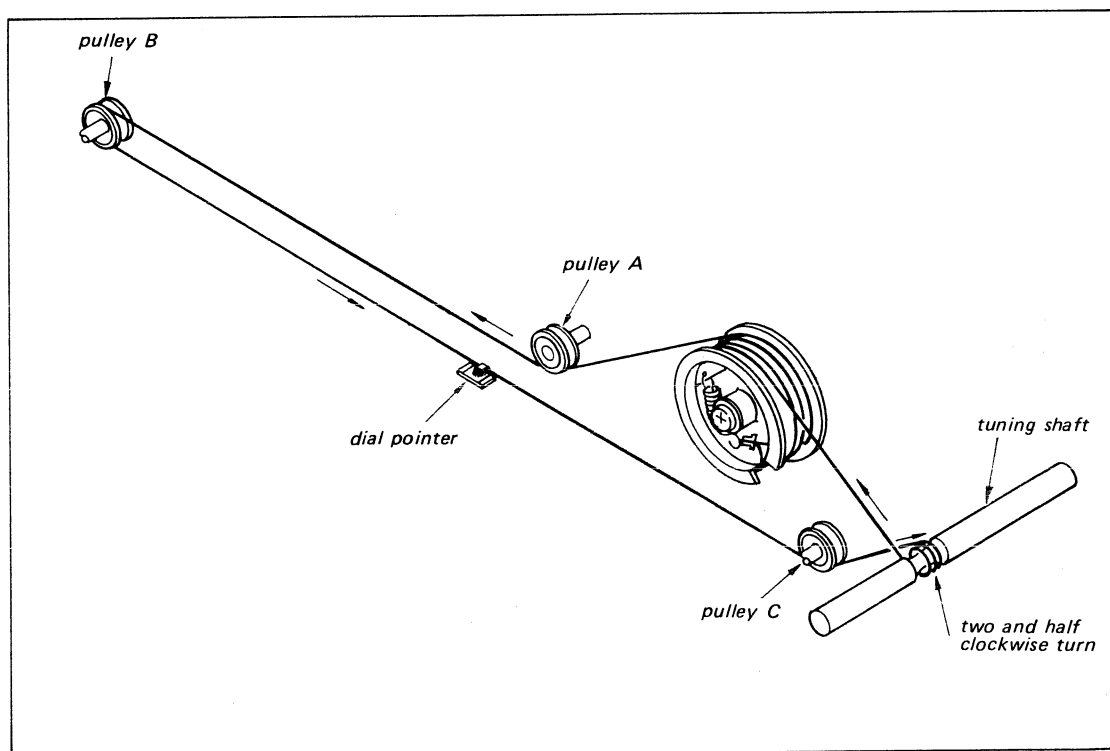

Fig. 2-9 Dial cord stringing

2-7. MECHANICAL DIAL CALIBRATION

Note: This is required after replacing the dial cord, dial scale or front-end assembly.

1. Put the dial pointer on the cord as shown in Fig. 2-12 and move it to a position where the pointer comes to about 4 mm ($\frac{1}{8}$ ") left from the lowest dial mark (87 MHz) as shown in Fig. 2-13, when the tuning-capacitor drive drum is rotated fully clockwise.
2. Apply a drop of contact cement to the tab of the dial pointer.

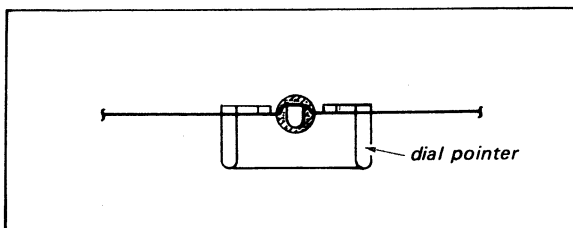

Fig. 2-12 Dial pointer installation

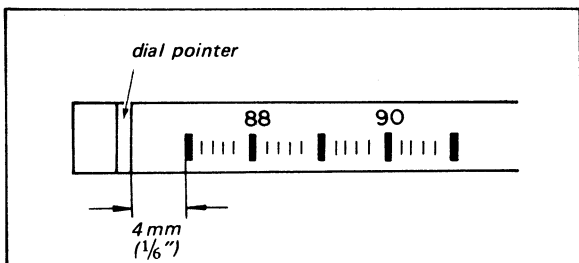

Fig. 2-13 Mechanical dial calibration

2-8. DIAL SCALE REPLACEMENT

1. Remove the top cover and front panel as described in Procedures 2-3 and 2-4.
2. Remove the two screws ($\text{#B } 3 \times 6$) securing the dial-scale holder to the front subchassis as shown in Fig. 2-5.
3. Remove the defective dial scale, and then install the replacement scale.

2-9. PILOT-LAMP REPLACEMENT

Prepare for replacement of any of the pilot lamps by removing the top cover as described in Procedure 2-3.

Meter Lamp

1. Straighten the tab of the meter-lamp holder to permit the removal of the meter-lamp socket.
2. Pull out the meter-lamp socket, and then unscrew the lamp from the socket and install the new lamp.

Stereo Lamp

1. Pull the lamp from its rubber holder with tweezers.
2. Unsolder the lead wires from the terminal strip, and then install the new lamp.

Dial Lamp

1. Remove the front panel as described in Procedure 2-4.
2. Pry out the defective lamp, and then install the new lamp.

2-10. METER REPLACEMENT

1. Remove the top cover as described in Procedure 2-3.
2. Unsolder the leads from the defective meter.
3. Remove the two screws ($\text{#PS } 3 \times 6$) securing the meter holder to the front subchassis as shown in Fig. 2-3.
4. Remove the meter, and install the new one.

2-11. CONTROL AND SWITCH REPLACEMENT

Prepare for replacing any of the controls or switches by removing the front panel as described in Procedure 2-4.

POWER, LOW FILTER, HIGH FILTER, MONITOR, FUNCTION (1), LOUDNESS, FM MODE, HIGH BLEND and MUTING Switches

1. Remove the two screws ($\text{#B } 3 \times 6$) securing switches to the front subchassis as shown in Fig. 2-5. Note that the upper screw of FUNCTION switch (1) is ($\text{#B } 3 \times 4$).
2. Unsolder the lead wires from the defective switch, and then install the replacement switch.

SPEAKER, MODE, FUNCTION (2) Switches and VOLUME/BALANCE Control

1. Remove the hex nuts that secure the switches or controls to the front subchassis as shown in Fig. 2-5.
2. Unsolder the lead wires from the defective switch or controls, and then install the new one.

HEADPHONE, LINE OUT and AUX-3 Jacks

1. Remove the front subchassis as described in Procedure 2-5.
2. Remove the two screws ($\text{#B } 3 \times 6$) securing the jack bracket to the front subchassis.

3. Unsolder the lead wires from the defective jack, and then install the new one.

2-12. POWER TRANSISTOR REPLACEMENT

1. Remove the top cover and bottom plate as described in Procedure 2-3.
2. Remove the four self-tapping screws ($\text{Ø} B 3 \times 8$) securing top heat sink bracket as shown in Fig. 2-14.
3. Remove the four self-tapping screws ($\text{Ø} B 3 \times 8$) securing a pair of heat sink to the chassis as shown in Fig. 2-15.
4. Carefully draw back the heat sink, see Fig. 2-16 and then remove the two screws ($\text{Ø} B 3 \times 14$), ($\text{Ø} B 3 \times 16$) and plate nut securing the power transistor and power transistor socket to the heat sink.
5. When replacing the power transistor, apply a coating of a heat-transferring grease to both sides of the insulating mica washer. Any excess grease squeezed out when the mounting bolts are tightened should be wiped off with a clean cloth. This prevents it from accumulating conductive dust particles that might eventually cause a short.

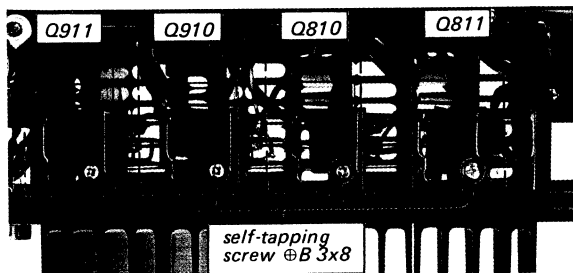

Fig. 2-14 Top heat sink bracket removal

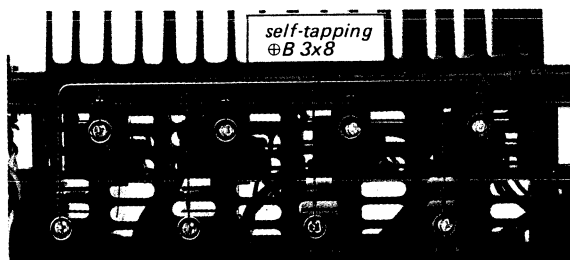

Fig. 2-15 Heat sink removal

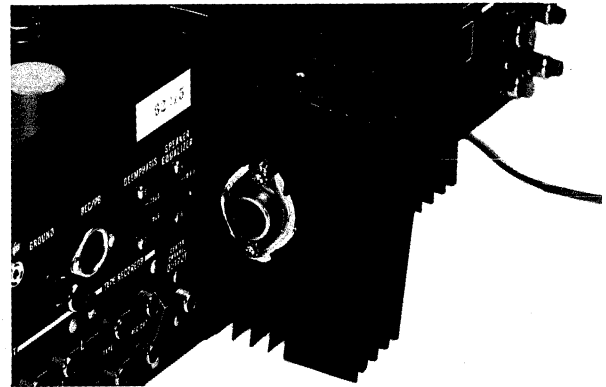

Fig. 2-16 Power transistor removal

2-13. REAR PANEL REMOVAL

1. Remove the top cover and bottom plate as described in Procedure 2-3.
2. Remove the self-tapping screw ($\text{Ø} B 3 \times 6$) securing the terminal strip to the chassis on which the fuse is soldered.
3. Remove the four screws ($\text{Ø} B 2.6 \times 4$) securing DE-EMPHASIS and SPEAKER EQUALIZER switches to the rear panel as shown in Fig. 2-4.
4. Unsolder the coaxial cable from the balun board and braided wire connecting between balun board and chassis.
5. Remove the two self-tapping screws ($\text{Ø} B 3 \times 6$) at each side of the chassis as shown in Fig. 2-4. This frees the rear panel as shown in Fig. 2-17.

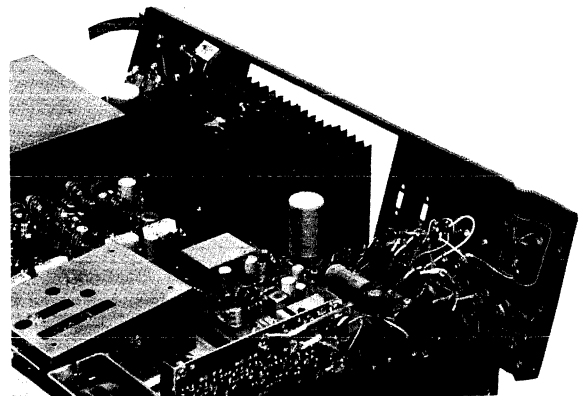

Fig. 2-17 Rear panel removal

2-14. REPLACEMENT OF COMPONENTS SECURED TO THE REAR PANEL BY RIVETS

1. Remove the rear panel as described in Procedure 2-13.
2. Bore out the rivets using a drill bit slightly larger in diameter than the rivet. See Fig. 2-18.
3. Punch out the remainder of the rivet with a nail set or prick punch.
4. Remove the defective component, and then install a new one.
5. Secure the new component with a suitable screw and nut, or a repair rivet screw (part number 3-701-402).

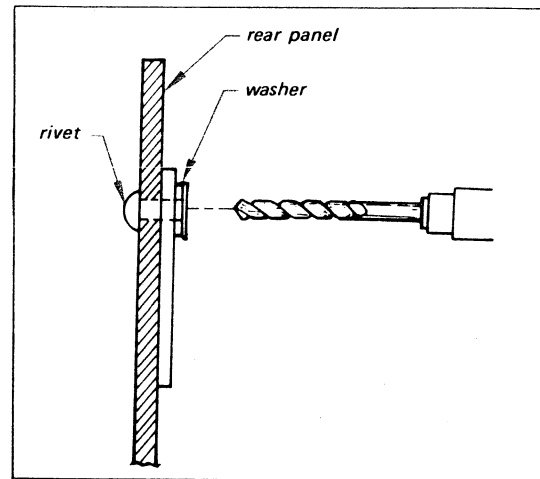
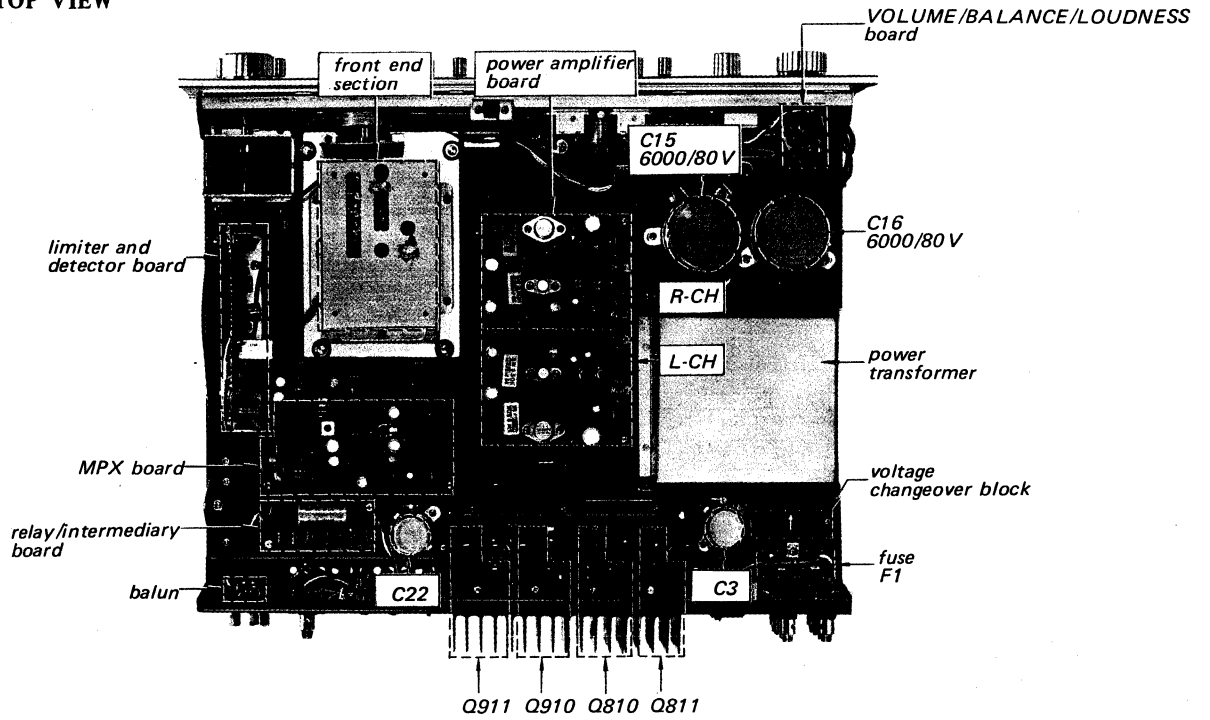

Fig. 2-18 Rivet replacement

2-15. CHASSIS LAYOUT

TOP VIEW



BOTTOM VIEW

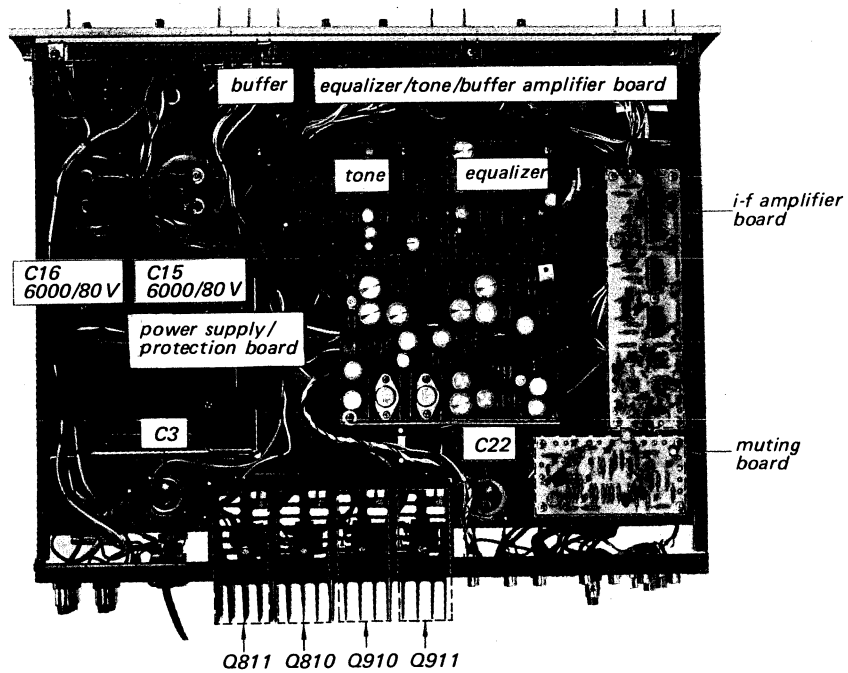

**SECTION 3
ALIGNMENT AND ADJUSTMENT PROCEDURES**

3-1. FM I-F STRIP ALIGNMENT

CAUTION

The ceramic filters in the fm i-f circuit are selected according to their specified center frequencies and color coded as shown in Fig. 3-1 and listed in Table 3-1. Check the color code of the filters to identify the same center frequency when replacing any of these filters.

**TABLE 3-1
FM I-F CERAMIC FILTERS**

Part No.	Color	Specified Center Freq.
1-403-564-11	red	10.70 MHz
1-403-564-21	black	10.66 MHz
1-403-564-31	white	10.74 MHz
1-403-564-41	green	10.62 MHz
1-403-564-51	yellow	10.78 MHz

Test Equipment Required

1. Standard fm signal generator
2. Ac VTVM
3. Oscilloscope
4. Alignment tools

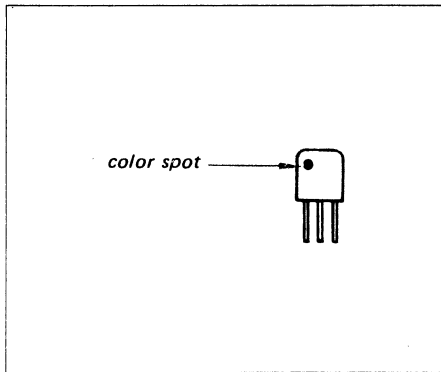

Fig. 3-1 Fm i-f ceramic filter

Note: Fm i-f strip alignment should be performed only after replacing IFT101 in the front end.

Preparation

1. Remove the top cover as described in Procedure 2-3.
2. Remove the front-end cover by loosening the two screws securing it to the chassis.
3. Connect the input cable of the ac VTVM to the REC OUT Jack (J606).
4. Connect the signal-generator's output to the

fm antenna terminal.

5. Short the connection point of R330 and C327 on the relay/intermediary board (AFC circuit) to ground as shown in Fig. 3-2.

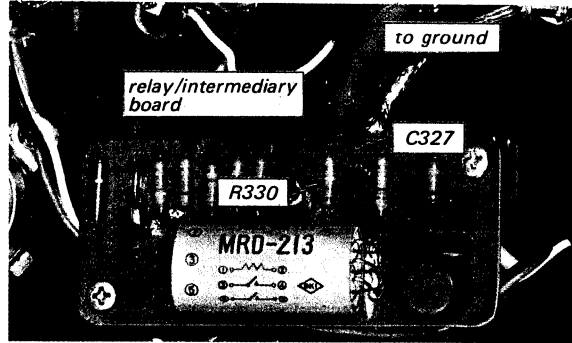

Fig. 3-2 Interruption of afc circuit

Procedure

1. With the equipment connected as shown in Fig. 3-4, set the signal-generator's controls as follows:
 - Carrier frequency.... 98 MHz
 - Modulation..... Fm, 400 Hz, 30% (22.5 kHz)
 - Output level 30 μ V (30 dB)
2. Set the receiver's controls as follows:
 - FUNCTION (2) switch FM
 - FM MODE switch AUTO ST
 - MODE switch STEREO
 - VOLUME control minimum
3. Precisely tune the set to the SSG's carrier frequency then turn the core of transformer IFT101 and primary side of discriminator transformer IFT301 (bottom core) (see Figs. 3-3 and 3-6) with the alignment tool to obtain maximum output.

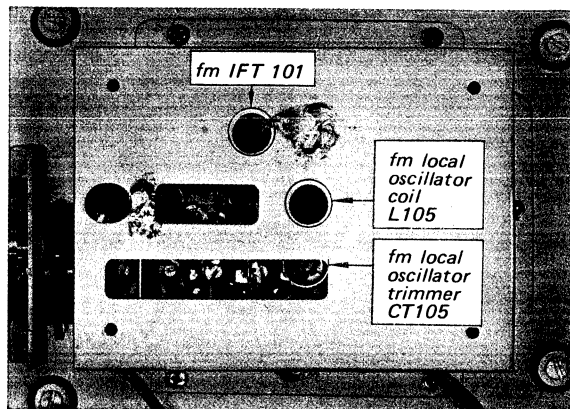

Fig. 3-3 Parts location

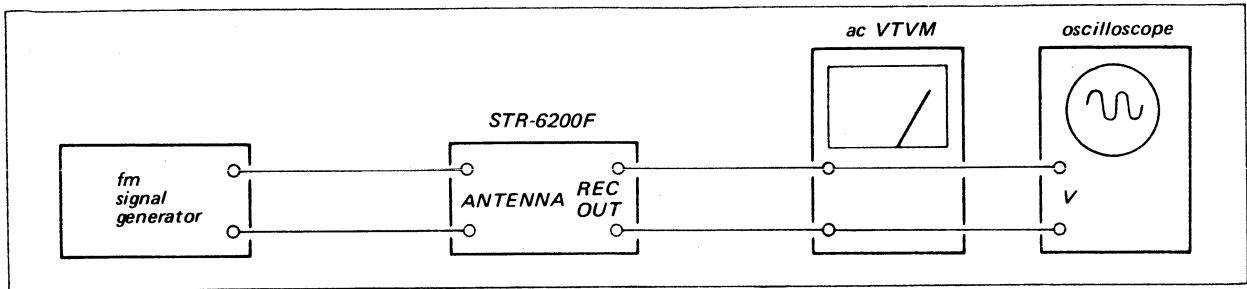

Fig. 3-4 Fm i-f, discriminator, muting and front end alignment test setup

3-2. FM DISCRIMINATOR ALIGNMENT

Note: There are two or three methods of discriminator alignment, but only the simplified method using the tuner's TUNING meter is described here.

Test Equipment Required

1. Oscilloscope
2. Alignment tools

Preparation

1. Remove the top cover as described in Procedure 2-3.
2. Connect the input cable of the oscilloscope to REC OUT Jack (J606).
3. Short the connection point of R330 and C327 on the relay/intermediary board (AFC circuit) to ground as shown in Fig. 3-2.

2. Adjust the controls of the oscilloscope to provide a visible indication of noise. Always watch the oscilloscope to confirm that the tuner is not receiving any off-the-air signal.
3. Turn the top core (secondary side) of IFT301 discriminator transformer (see Fig. 3-6) with a hex-head alignment tool to obtain a null-point reading on the tuning meter. If the discriminator transformer (IFT301) is not aligned correctly, some deviation on the tuning meter will be observed.

Note: Turn the core carefully and slowly. At both extreme positions of the top core, a null point will be observed. The real null point should be obtained in the middle of the core thread length.

4. Adjust the dc-balance control R319 (5k) (see Fig. 3-6) to obtain a symmetrical deflection of TUNING meter (see Fig. 3-14) when detuning higher or lower than the reference carrier frequency while applying rf signal as follows:
 Carrier frequency 98 MHz
 Modulation Fm, 400 Hz, 30%
 Output level 1,000 μ V (60 dB)
5. Repeat the above mentioned steps and fm i-f strip alignment (procedure 3-1) alternately two or three times.

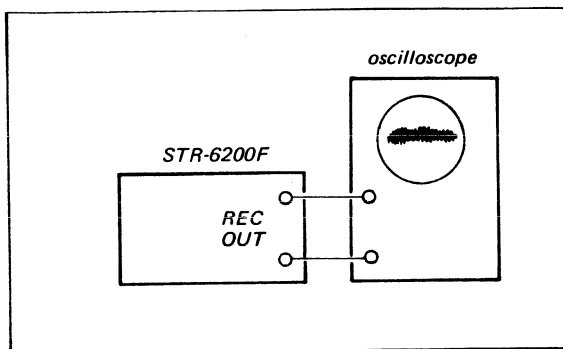

Fig. 3-5 Discriminator alignment test setup

Procedure

1. With the equipment connected as shown in Fig. 3-5, set the receiver's control as follows:
 FUNCTION (2) switch FM
 FM MODE switch AUTO ST
 MODE switch STEREO
 VOLUME control minimum
 No signal should be received.

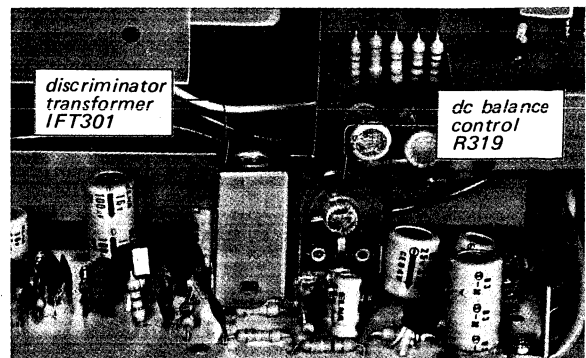

Fig. 3-6 Parts location

3-3. FM FREQUENCY COVERAGE ALIGNMENT

MODE switch STEREO
 VOLUME control minimum

CAUTION

Never attempt alignment of the front-end section except for the frequency-coverage and dial-calibration adjustments. The front-end section of the tuner has been carefully adjusted at the factory, so very little adjustment is necessary in the field. Alignment need not be performed when the front-end FET is replaced since changes in FET parameters have little effect upon tuning. If an rf-stage adjustment is required, ask your nearest SONY Service Station to send your unit to the Factory Service Center for a complete front-end alignment. Exercise caution when returning the faulty unit so that it is not damaged in transit. The warranty will not cover damage incurred in transit to the Factory Service Center.

Note: Before starting this alignment, the discriminator-transformer alignment should be performed.

Test Equipment Required

1. Standard fm signal generator
2. Ac VTVM
3. Alignment tools

Preparation

1. Remove the top cover as described in Procedure 2-3.
2. Short the connection point of R330 and C327 (AFC circuit) to ground as shown in Fig. 3-2.
3. Connect the equipment as shown in Fig. 3-4.
4. Set the receiver's controls as follows:
 FUNCTION (2) switch FM
 FM MODE switch AUTO ST

Generator Alignment

Follow the procedures given in Table 3-2 when performing this alignment with an fm signal generator. Be sure that the dial is mechanically calibrated as described in Procedure 2-6.

Off-the-Air Alignment

Accurate dial calibration and a frequency-coverage test can also be performed by utilizing off-the-air local fm signals. However, before performing the following procedure, be sure that the dial pointer is correctly positioned, as described in Procedure 2-6.

Procedure

1. Tune the receiver to the lowest-frequency station.
2. Check the dial scale for a calibration accuracy of ± 100 kHz from the carrier frequency of the station. If the dial-accuracy deviation exceeds this limit, turn the local-oscillator coil L105 slightly as shown in Fig. 3-3 until optimum dial calibration is obtained.
3. Tune the receiver to the highest-frequency station in your locality. If the dial-calibration error is excessive, adjust local-oscillator trimmer CT105 (see Fig. 3-3) to obtain maximum calibration accuracy.

3-4. FM STEREO SEPARATION ADJUSTMENT

Test Equipment Required

1. MPX generator
2. Fm signal generator
3. Audio oscillator

TABLE 3-2 FM FREQUENCY COVERAGE ALIGNMENT

Step	Coupling Between Front End and SSG	SSG Frequency and Output Level	Tuner Dial Indication	Scope Connection	Adjust	Indication
1.	Direct coupling	87.5 MHz 400 Hz 30% Mod. 30 μ V (30 dB)	87.5 MHz	REC OUT Jack (J606)	OSC coil L105 See Fig. 3-3	Maximum VTVM reading
2.	Same as above	108 MHz 400 Hz 30% Mod. 30 μ V (30 dB)	108 MHz	Same as above	OSC trimmer CT105 See Fig. 3-3	Same as above

4. Ac VTVM
5. Oscilloscope
6. Alignment tools

Preparation

Before starting the stereo-separation adjustment, check and adjust the phase between the 19-kHz pilot signal and the sub-channel signal in the MPX stereo generator as follows:

1. With the equipment connected as shown in Fig. 3-7, set the MPX and audio signal-generator's controls as follows:
 - MAIN CHANNEL OFF
 - SUB CHANNEL ON
 - PILOT (19 kHz) OFF
 - AUDIO OSCILLATOR
 - OUTPUT 400 Hz, 250 mV

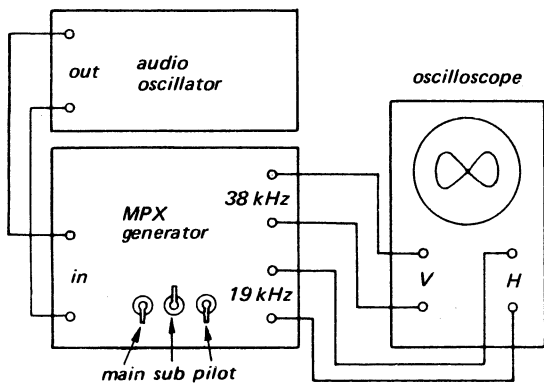

Fig. 3-7 MPX generator preadjustment

2. Adjust the oscilloscope controls to obtain a visible indication. Be sure the scope's horizontal display-switch is set for external input.
3. Turn the pilot-signal (19 kHz) phase control to obtain an in-phase and stable lissajous pattern as shown in Fig. 3-8.

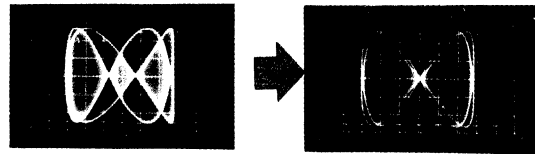

Fig. 3-8 Lissajous pattern

Procedure

1. Connect the equipment as shown in Fig. 3-9. Set the fm signal-generator's control as follows:
 - Carrier frequency 98 MHz
 - Output level 1,000 μV (60 dB)
 - Modulation:
 - Main channel (400 Hz) ... 33.75 kHz (45%)
 - Sub channel (38 kHz) 33.75 kHz (45%)
 - Pilot (19 kHz) 7.5 kHz (10%)

The above mentioned modulation levels can be set as follows:

- (a) With the equipment connected as shown in Fig. 3-9 set the MPX stereo generator controls as follows:
 - MAIN CHANNEL OFF
 - SUB CHANNEL OFF
 - 19 kHz (PILOT) ON
- (b) Adjust the 19-kHz signal level to obtain a 7.5-kHz deviation on the FM SSG modulation indicator.
- (c) Reset the MPX stereo-generator's control as follows:
 - MAIN CHANNEL ON
 - SUB CHANNEL OFF
 - 19 kHz (PILOT) OFF
 - INPUT SELECTOR L-CH
- (d) Adjust the audio-oscillator output (400 Hz) to obtain a 33.75-kHz deviation on the FM SSG modulation indicator.
- (e) Set all controls to the ON position.

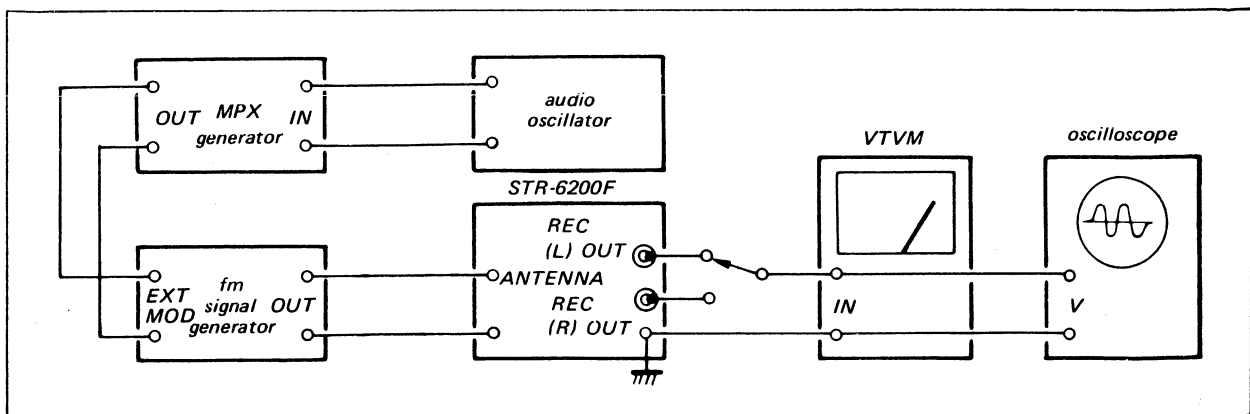

Fig. 3-9 Fm stereo separation adjustment test setup

2. Precisely tune the set to the SSG's carrier frequency, then turn the top core of switching transformer T501, to obtain maximum output at the left channel. See Fig. 3-10. Note that this adjustment has a close relationship with stereo distortion.
3. Record the output level of the left channel when the MPX generator input selector is set to the left channel.
4. Switch the input selector to the right channel and read the residual signal level in the left channel.
5. The output-level to residual-level ratio represents the separation. Adjust separation adj. control R547 (See Fig. 3-10) for minimum residual level. Check the right channel for separation. Usually, about an 8 to 9 dB difference in channel separation exists. Re-adjust R547 for minimum difference between left- and right-channel separation. While doing this, remember that the output level also changes according to the setting of R547.

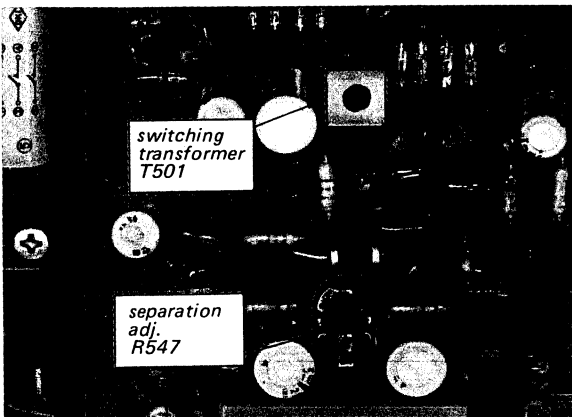

Fig. 3-10 Parts location

3-5. MUTING ADJUSTMENT

Note: Readjustment is necessary after replacing Q401 (FET) or if the muting point upon tuning meter deflection is not

symmetrical when detuning higher or lower than the reference carrier frequency. Two methods of muting adjustment are available, signal generator alignment and alignment by using an off-the-air signal. You can use either of them.

Signal Generator Adjustment

Test Equipment Required

1. Fm standard signal generator
2. Ac VTVM or oscilloscope
3. Screwdriver with 3 mm (1/8") blade

Preparation

1. Remove the top cover as described in Procedure 2-3.
2. Short the connection point of R330 and C327 on the relay/intermediary board (AFC circuit) to ground as shown in Fig. 3-2.

Procedure

1. With the equipment connected as shown in Fig. 3-4 set the signal generator's and receiver's controls as follows:

Carrier frequency 98 MHz
 Modulation Fm, 400 Hz, 30%
 Output level 1,000 μ V (60 dB)
 FUNCTION (2) switch ... FM
 FM MODE switch AUTO ST
 MUTING switch ON
 VOLUME control minimum

2. Follow the procedure given in Table 3-3. Note that the muting circuit should begin to operate at the symmetrical deflection point of higher or lower than the reference carrier frequency.

Off-the-Air Signal Alignment

Accurate muting circuit adjustment can also be performed by utilizing an off-the-air local fm signal instead of the fm SSG.

TABLE 3-3 MUTING ADJUSTMENT

Coupling Between Front End and SSG	SSG Frequency and Output Level	Tuner Dial Indication	Adjust	Remarks
Direct coupling	98 MHz 400 Hz 30% Mod. 1,000 μ V (60 dB)	98 MHz	R403 See Fig. 3-11 (MUTING Board)	Turn R403 to obtain proper muting operation.

3-6. TUNER INPUT-METER CALIBRATION

Test Equipment Required

1. Fm standard signal generator
2. Screwdriver with 3 mm (1/8") blade

Preparation

1. Remove the top cover as described in Procedure 2-3.

Procedure

1. With the equipment connected as shown in Fig. 3-4, set the receiver's controls as follows:
FUNCTION (2) switch FM
2. Follow the procedure given in Table 3-4.

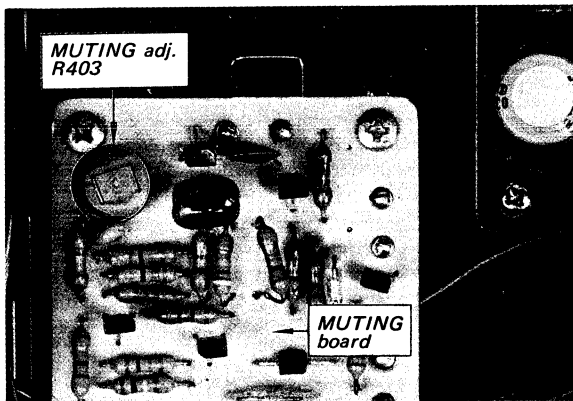

Fig. 3-11 Parts location

3-7. TUNING METER CALIBRATION

Test Equipment Required

1. Fm standard signal generator
2. Screwdriver with 3 mm (1/8") blade

Preparation

1. Remove the top cover as described in Procedure 2-3.

Procedure

1. With the equipment connected as shown in Fig. 3-4, set the receiver's controls as follows:
FUNCTION (2) switch FM
2. Follow the procedure given in Table 3-5.

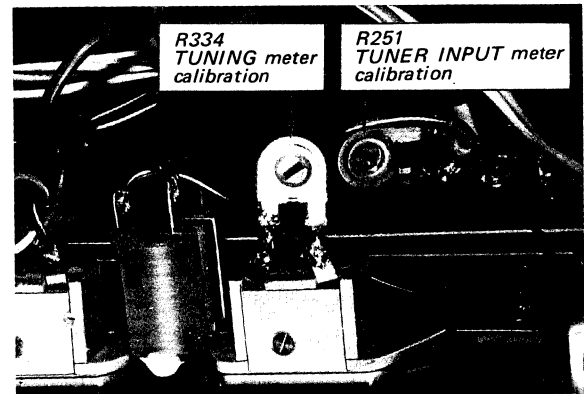

Fig. 3-12 Parts location

TABLE 3-4 TUNER INPUT-METER CALIBRATION

Coupling Between Front End and SSG	SSG Frequency and Output Level	Tuner Dial Indication	Adjust	Remarks
Direct coupling	98 MHz 400 Hz 30% Mod. 1,000 μ V (60 dB)	98 MHz	R251 See Fig. 3-12	Turn the R251 to obtain an indication of 2 ~ 3 mm (1/16 ~ 1/8") left from its maximum deflection as shown in Fig. 3-13.

TABLE 3-5 TUNING METER CALIBRAION

Coupling Between Front End and SSG	SSG Frequency and Output Level	Tuner Dial Indication	Adjust	Remarks
Direct coupling	98 MHz 400 Hz 30% Mod. 1,000 μ V (60 dB)	98 MHz	R334 See Fig. 3-12	Turn R334 to obtain the same specified deflection width when detuning higher or lower than the reference carrier frequency as shown in Fig. 3-14.

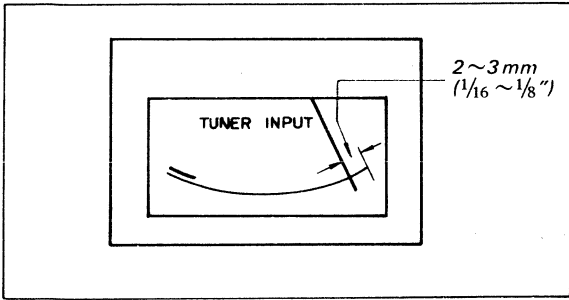

Fig. 3-13 TUNER INPUT meter calibration

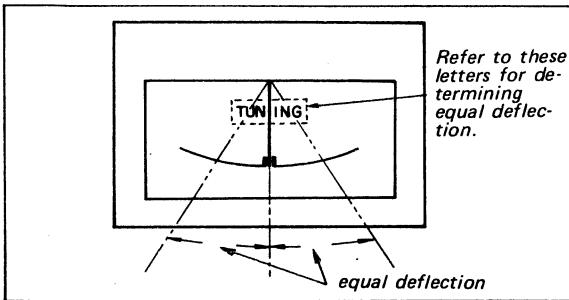

Fig. 3-14 TUNING meter calibration

3-8. POWER SUPPLY VOLTAGE ADJUSTMENT FOR TUNER SECTION

Test Equipment Required

1. Dc voltmeter:
Capable of measuring 25 V dc or more.
2. Screwdriver with 3 mm (1/8") blade

Preparation

1. Remove the bottom plate as described in Procedure 2-3.

Procedure

1. Turn the POWER switch to ON, and then measure the voltage between R8 (2.4k) and chassis as shown in Fig. 3-15.

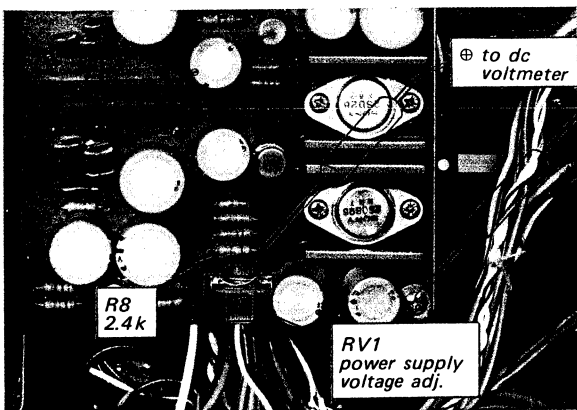

Fig. 3-15 Parts location

2. Adjust the semifixed resistor RV1 (see Fig. 3-15) to obtain a 24V reading on the meter.

3-9. POWER AMPLIFIER ADJUSTMENT

Note: There are two adjustment items in the power amplifier. One is dc-bias adjustment and the other is dc-balance adjustment. These adjustments should be alternately repeated two or three times after replacing any of the power transistors until the best operation is obtained.

Dc-Bias Adjustment

Serious deficiencies in performance, such as thermal runaway of power transistors, will result if this adjustment is improperly set.

CAUTION

To avoid accidental power transistor damage, increase the ac line voltage gradually, using a variable transformer, while measuring the voltage across emitter resistors (R836, R936) of power transistors alternately as shown in Fig. 3-16. Check to see that the reading does not exceed 25 mV. If it does, turn off the power as soon as possible, then check and repair the trouble in the power amplifier board.

Test Equipment Required

1. Dc millivoltmeter:
Capable of measuring dc voltage of 100 mV or less.
2. Variable transformer
3. Screwdriver with 3 mm (1/8") blade

Preparation

1. Remove the top cover as described in Procedure 2-3.
2. Connect the dc millivoltmeter across emitter resistor R836 (R936) of power transistor Q810 (Q910) as shown in Fig. 3-16.

Procedure

1. Apply a drop of cement solvent to the semifixed resistors on the power amplifier board, and then set the semifixed resistors (see Fig. 3-17) on the power amplifier board as follows:

- RV802 (L-CH, dc-bias)..... fully counter-clockwise
- RV902 (R-CH, dc-bias)..... fully clockwise
- RV801, RV901 mid position (dc-balance)



Fig. 3-16 Dc millivoltmeter connection

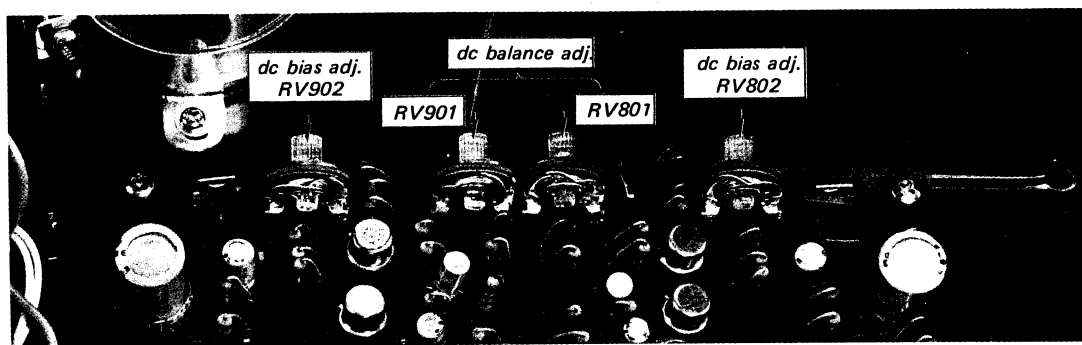

Fig. 3-17 Parts location

2. Set the variable transformer for minimum output.
3. Turn the POWER switch to ON, and then increase the line voltage up to the rated value.
4. Adjust RV802 and RV902 to obtain a 25 mV reading on the meter, and then follow the dc-balance adjustment.

Dc-Balance Adjustment

Excessive harmonic distortion at high levels or power transistor damage will result if this adjustment is improperly set.

Test Equipment Required

1. Dc null meter or dc millivoltmeter
2. Screwdriver with 3 mm ($1/8$ ") blade

Preparation

1. Set the SPEAKER switch to MAIN.
2. Connect the dc null meter or dc millivoltmeter to the MAIN speaker output terminal.

Procedure

1. Turn the POWER switch to ON, and then adjust RV801 (RV901) to obtain a 0V reading on the meter.
2. After 10 minutes warm-up, alternately repeat this and the dc-bias adjustment two or three times.
3. After completing the adjustment, apply a drop of lock paint to RV801 and RV902 (RV901 and RV902).

SECTION 4 REPACKING

The STR-6200F's original shipping carton and packing material are the ideal container for shipping the unit. However to secure the maximum pro-

tection, the STR-6200F must be repacked in these materials precisely as before. The proper repacking procedures are shown in Fig. 4-1.

- | | |
|---|--|
| X-37930-04
warranty card ass'y
(USA Model only) | 3-790-965-11
manual, instruction
(CANADA, General
Export Model) |
| X-44900-02
cloth, polishing | 3-790-965-31
manual, instruction
(USA Model) |
| 1-501-083
ribbon antenna, fm | 3-793-105
list, warranty station
(CANADA Model only) |
| 1-506-113
plug, shorting | 3-793-183
card, inspection |
| 1-506-138-11
phono plug, red | 3-796-836
SONY Hi-Fi warranty
(CANADA Model only) |
| 1-506-138-12
phono plug, white | 4-802-201
bag, polyethylene
(CANADA Model only) |
| 1-534-514-12
22
connecting cord, RK-81 | |
| 3-701-020
bag, polyethylene | |

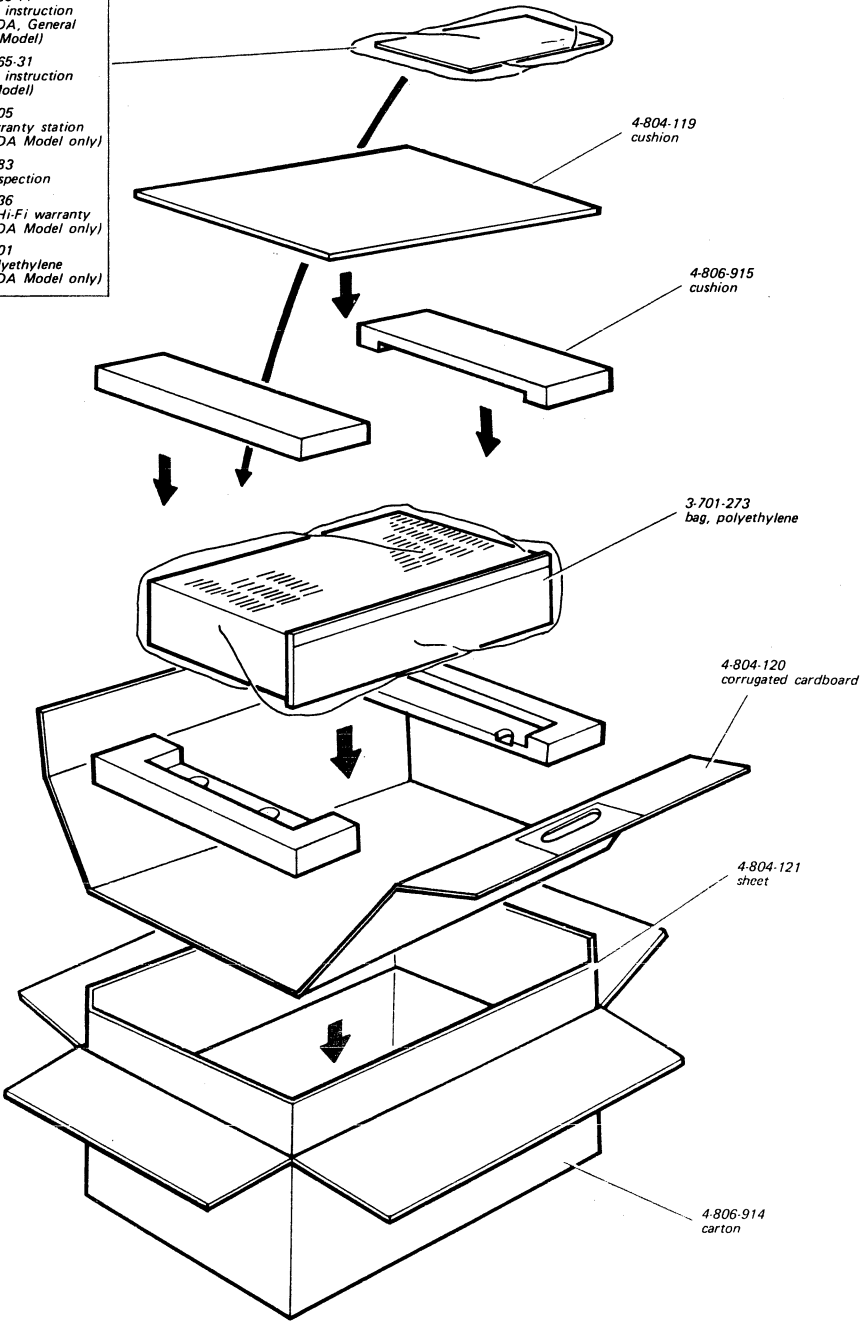

**SECTION 5
DIAGRAMS**

MOUNTING DIAGRAM – Balance/Volume/Loudness Control Board –

– Conductor Side –

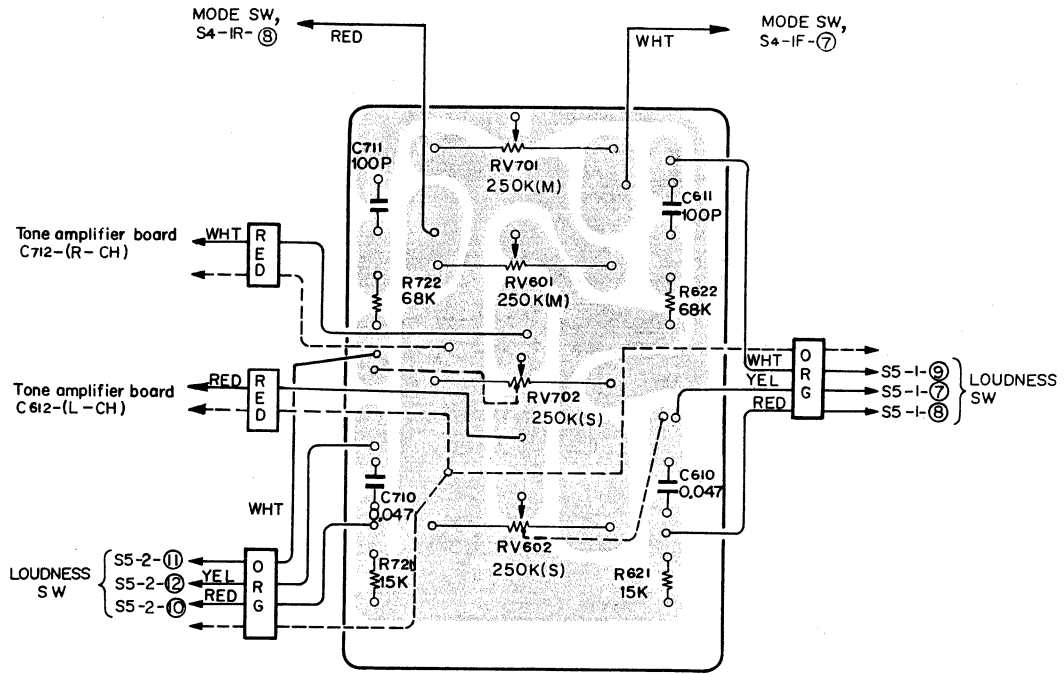

– Component Side –

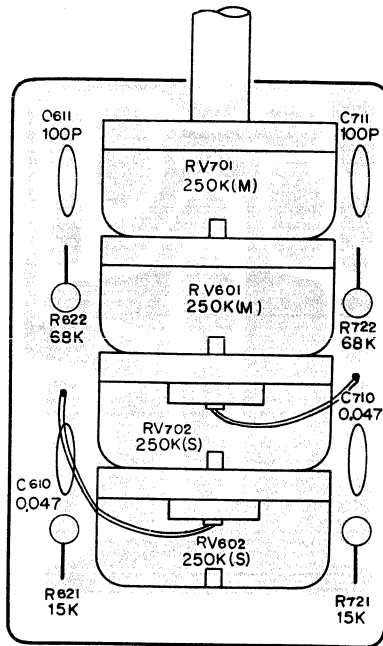

STR-6200F

MOUNTING DIAGRAM – Fm Front End –

– Conductor Side –

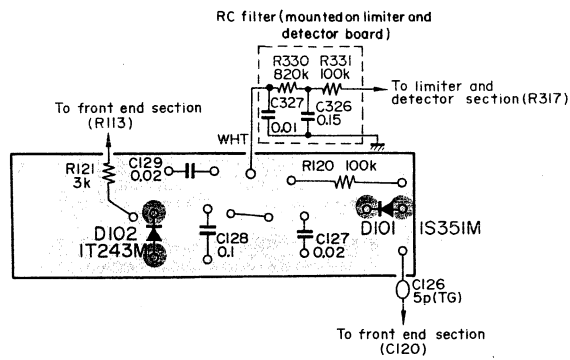
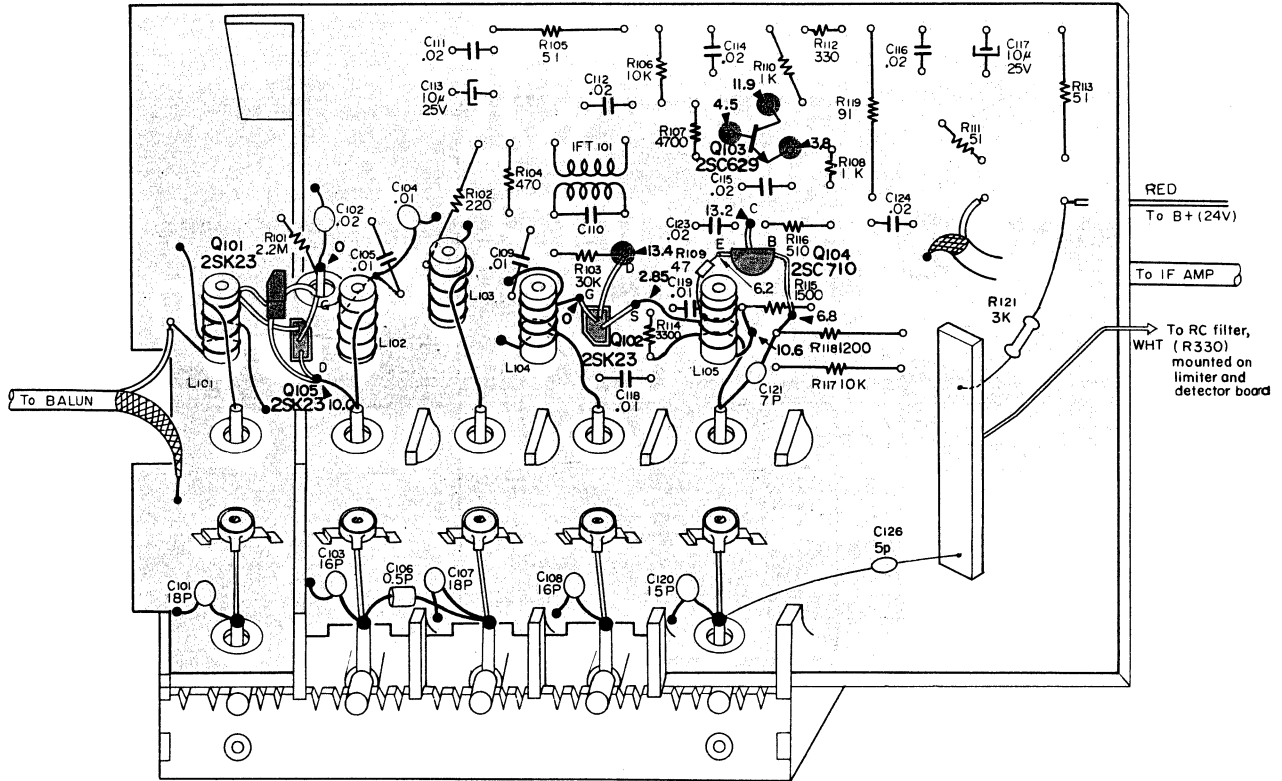

- Component Side -

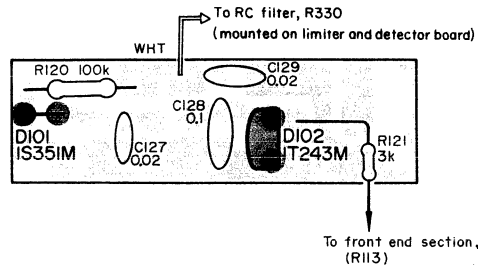
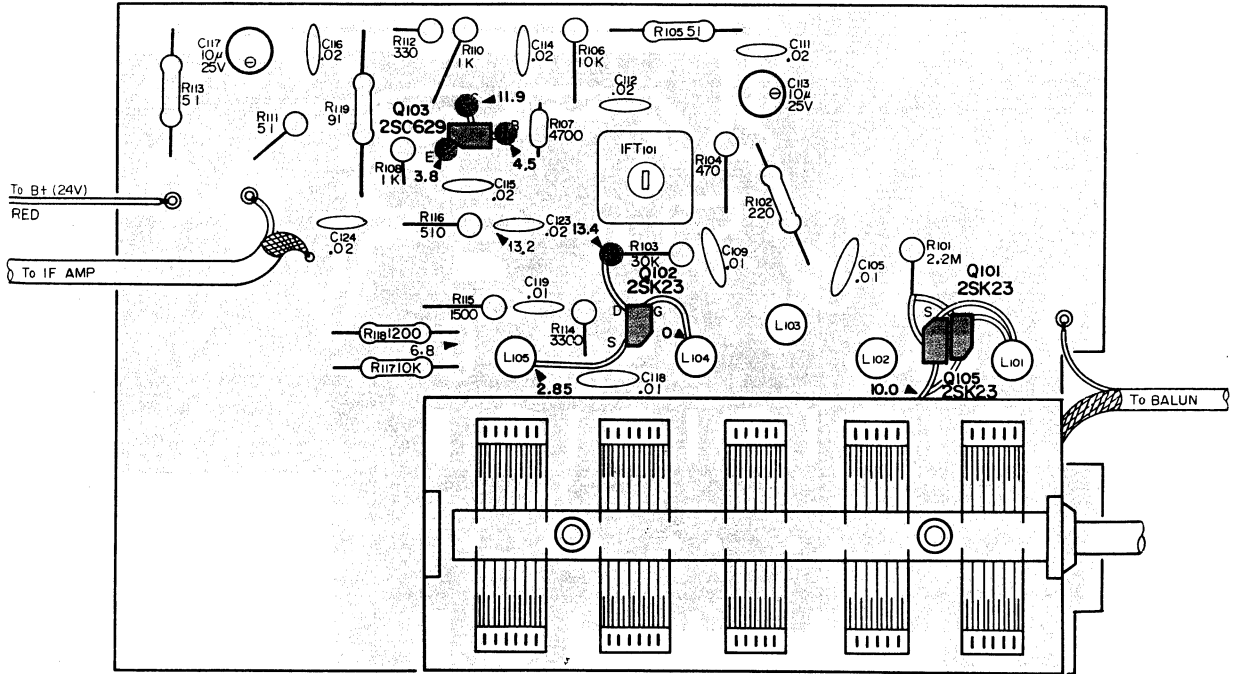

STR-6200F

MOUNTING DIAGRAM — Fm I-f Board —

— Conductor Side —

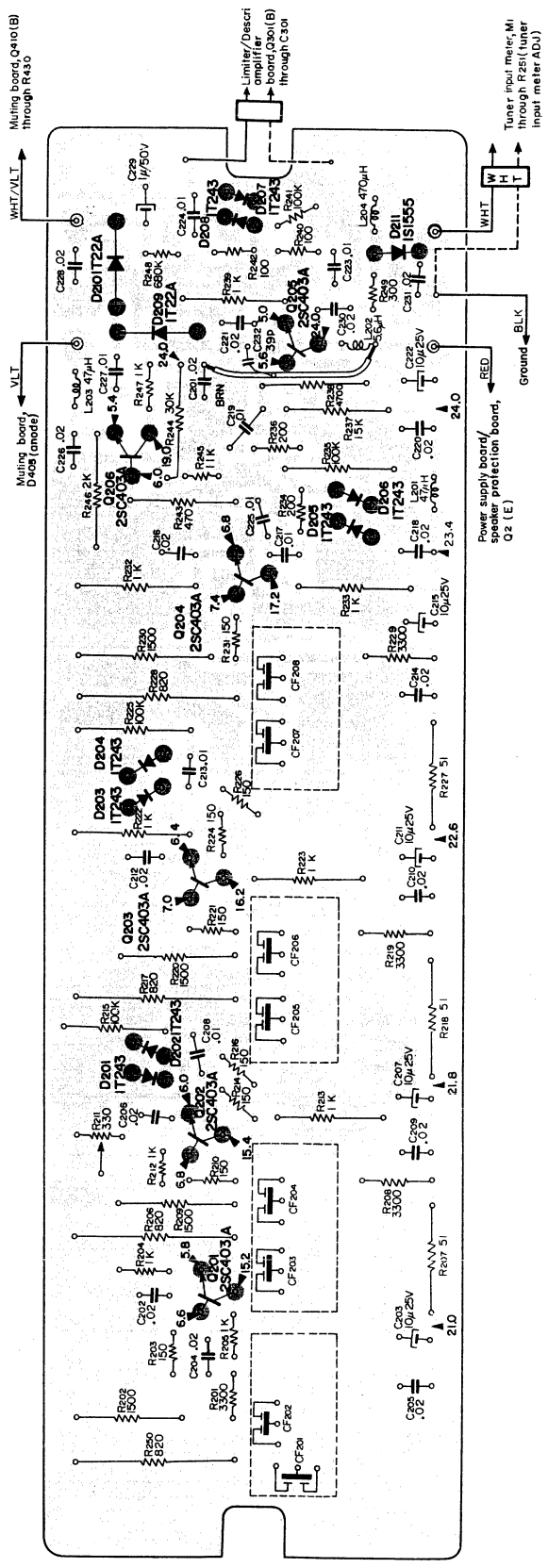

— Component Side —

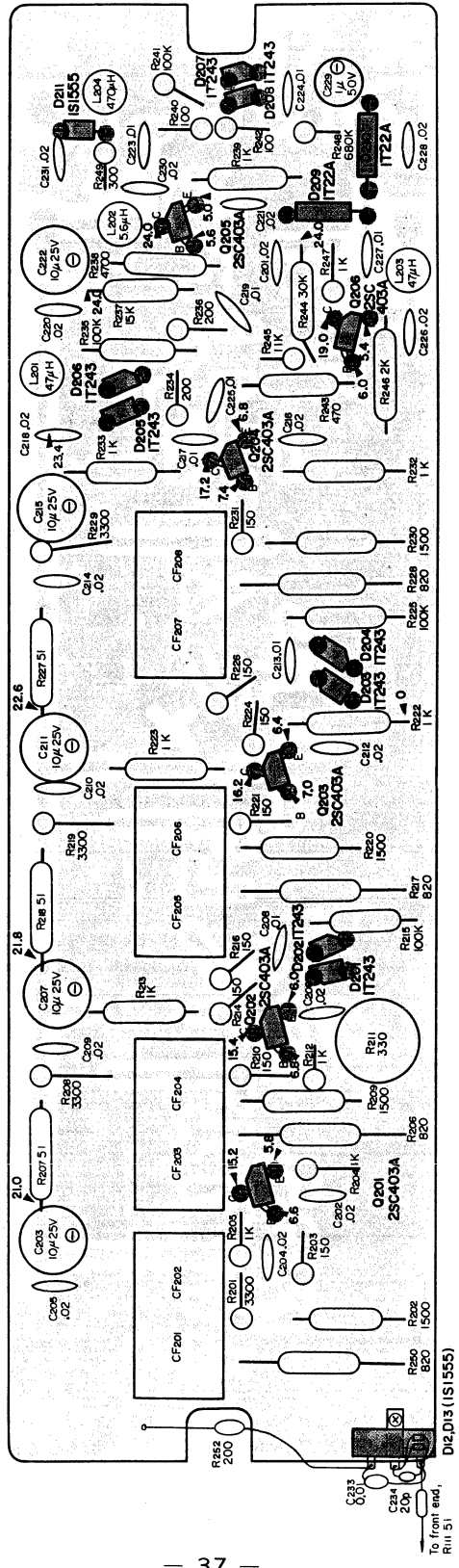

MOUNTING DIAGRAM – Limiter Detector Board –

– Conductor Side –

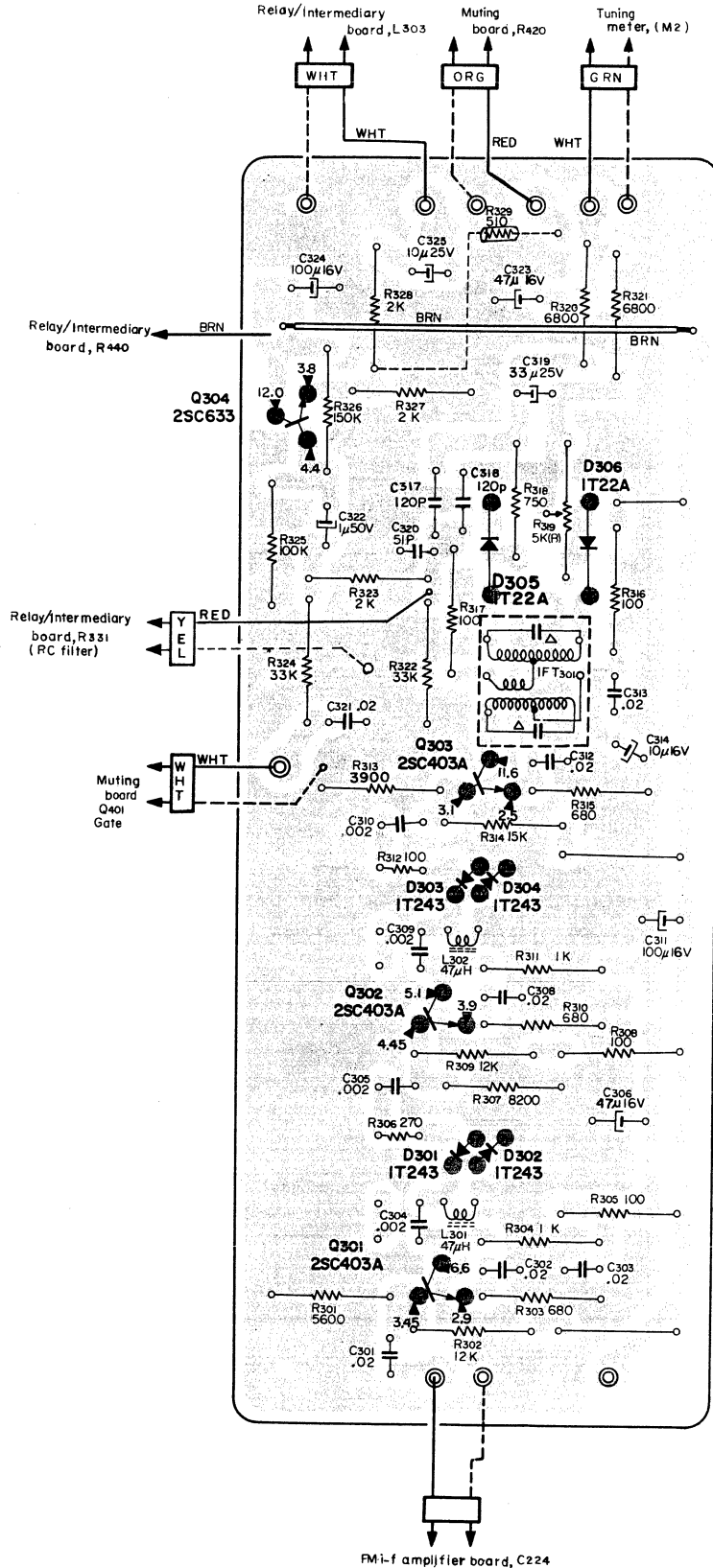

— Component Side —

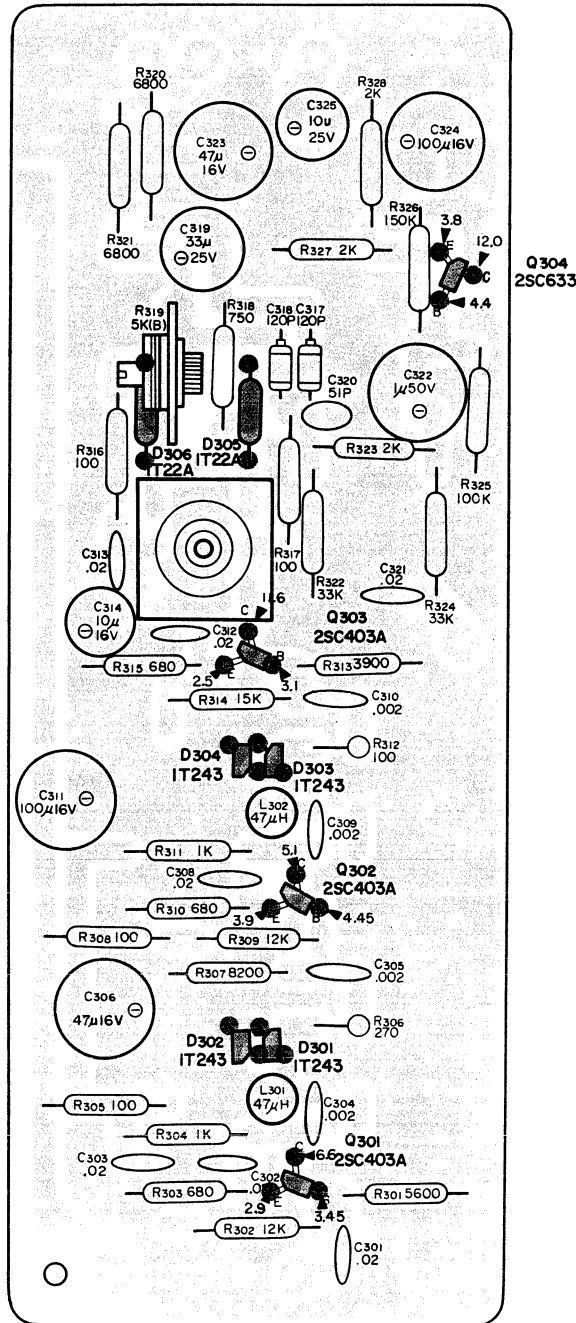

STR-6200F

MOUNTING DIAGRAM – MPX Board –

– Conductor Side –

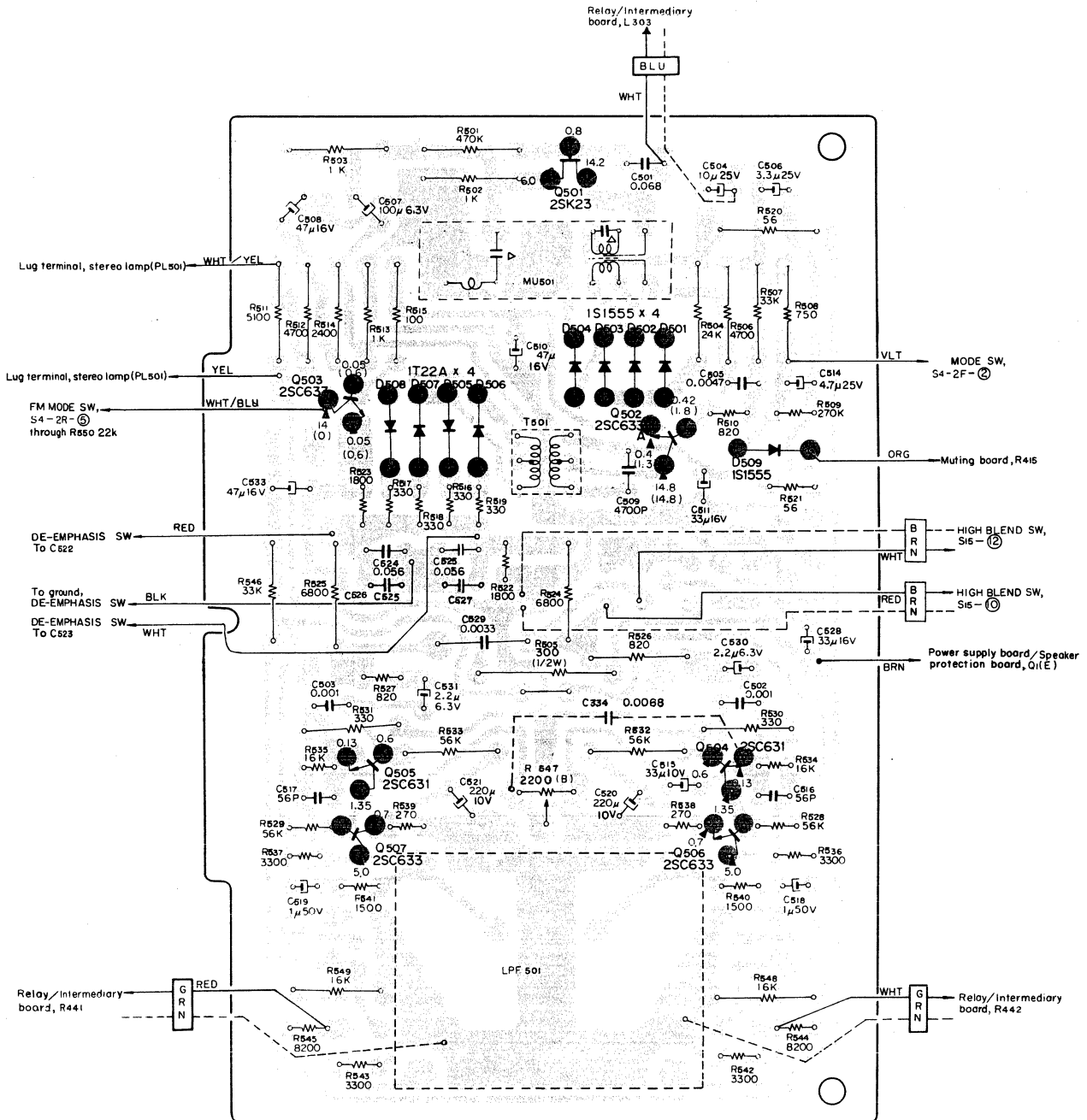

C334 is mounted on conductor side () ; STEREO OPERATION

— Component Side —

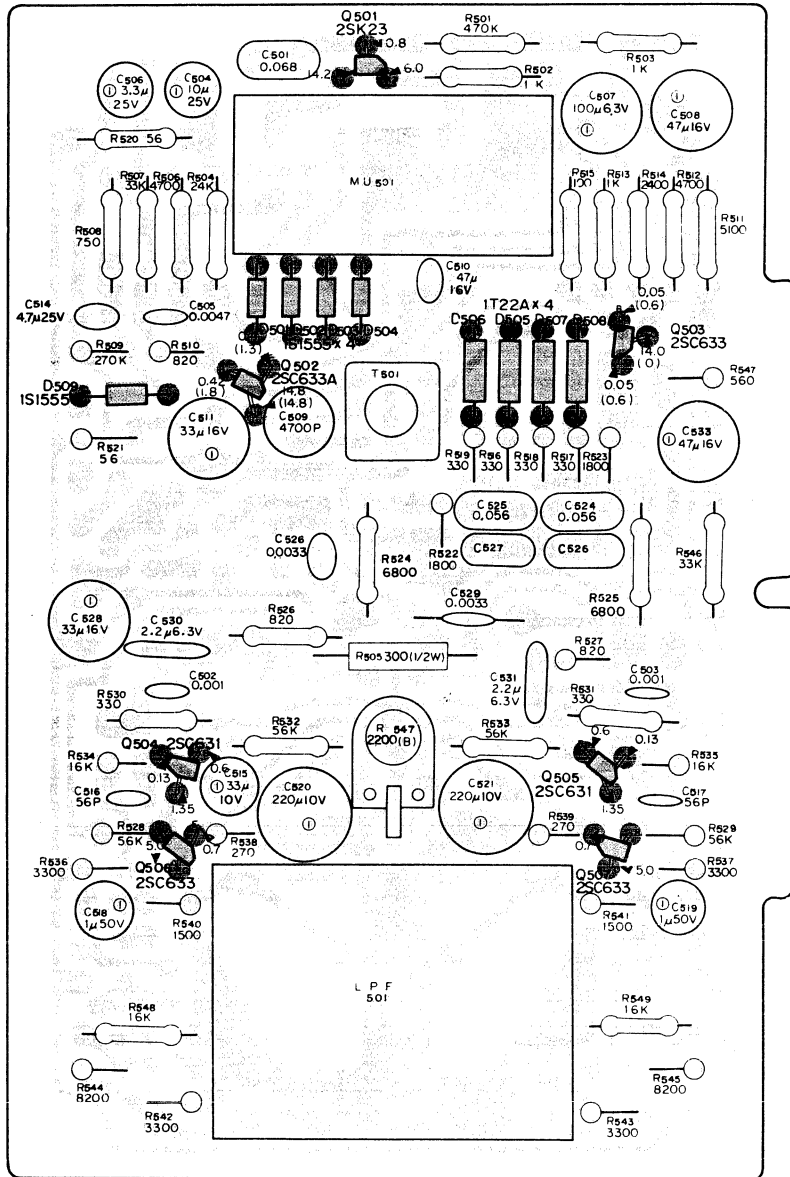

() ; STEREO OPERATION

STR-6200F

MOUNTING DIAGRAM – Muting Board –

– Conductor Side –

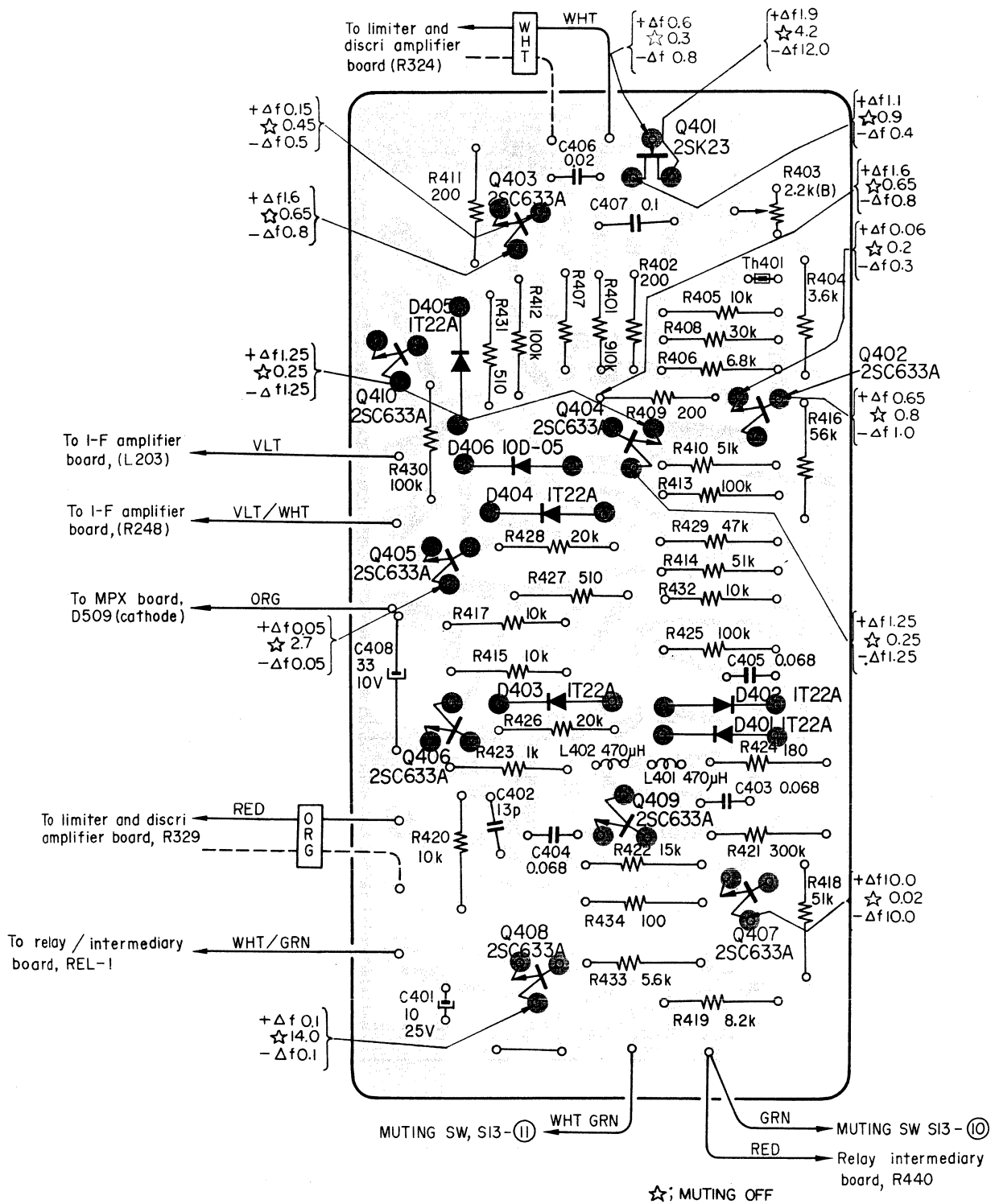

- Component Side -

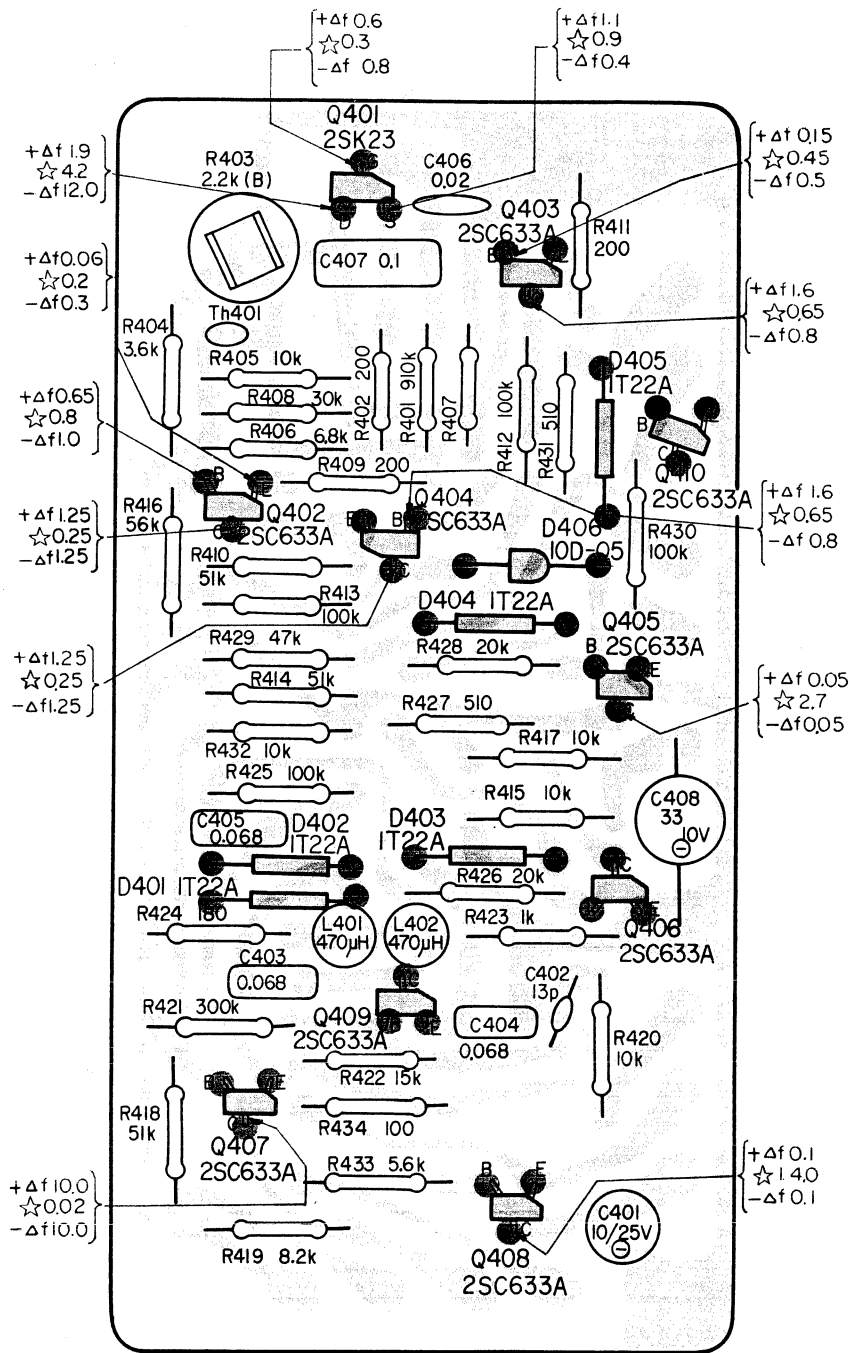

☆MUTING OFF

STR-620OF

MOUNTING DIAGRAM – Equalizer/Tone/Buffer Amplifier Board –

– Conductor Side –

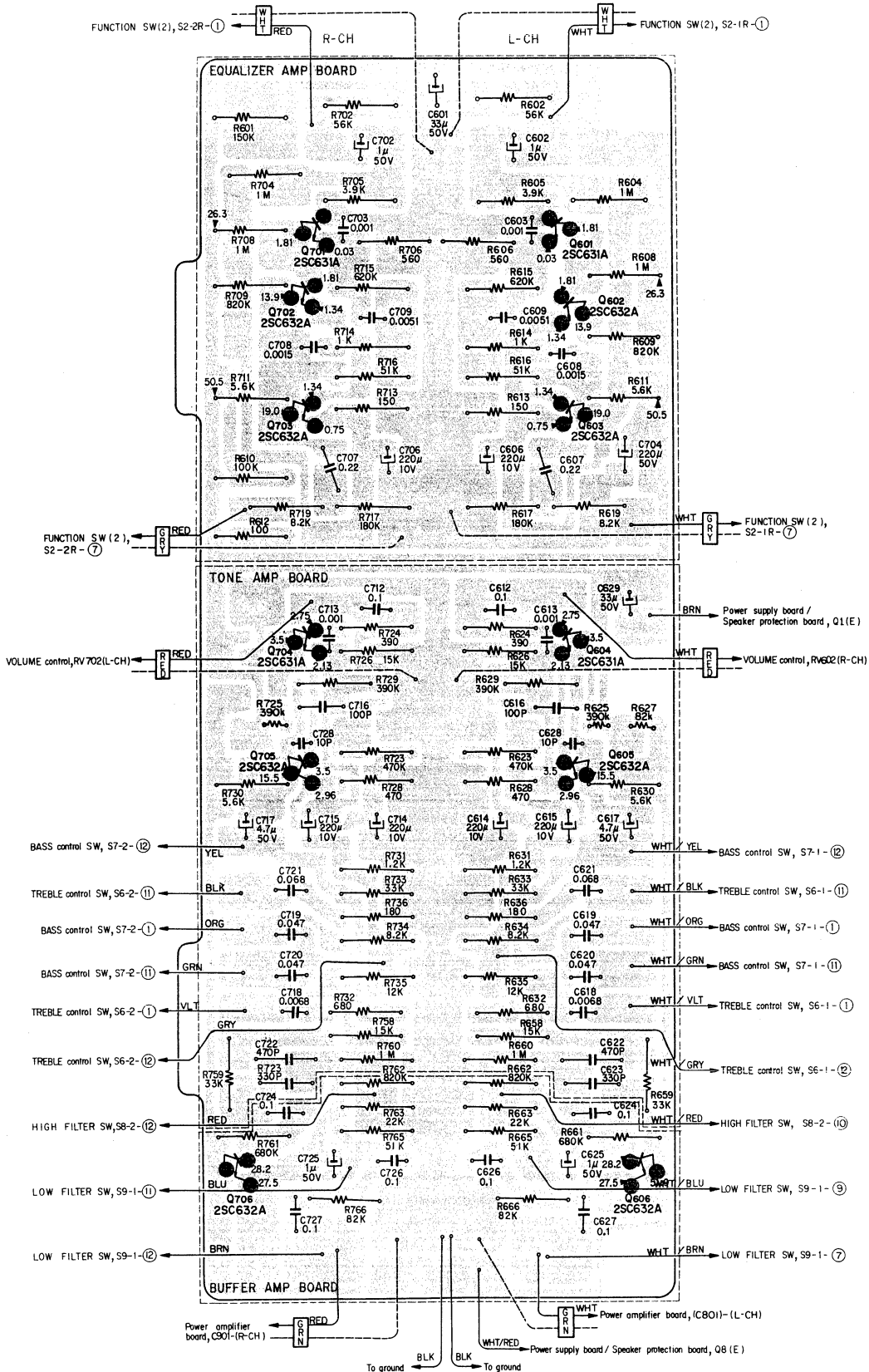

- Component Side -

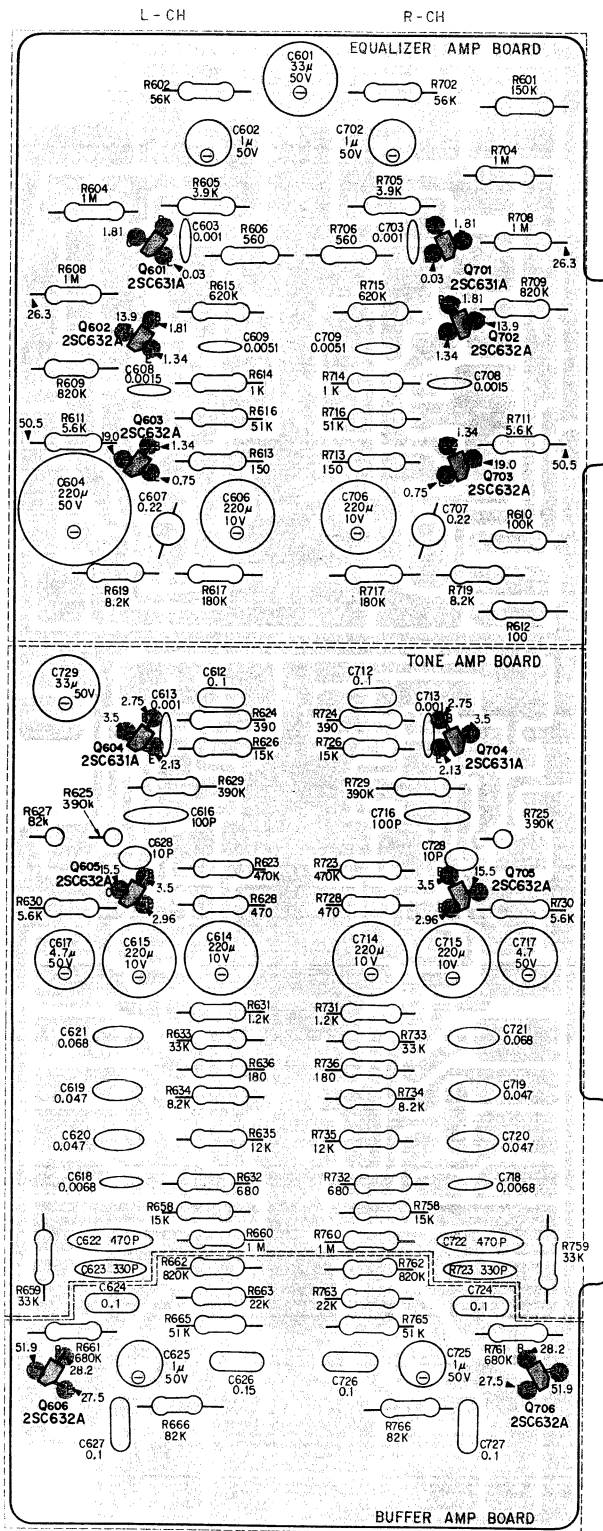

MOUNTING DIAGRAM - Power Amplifier Board -

- Conductor Side -

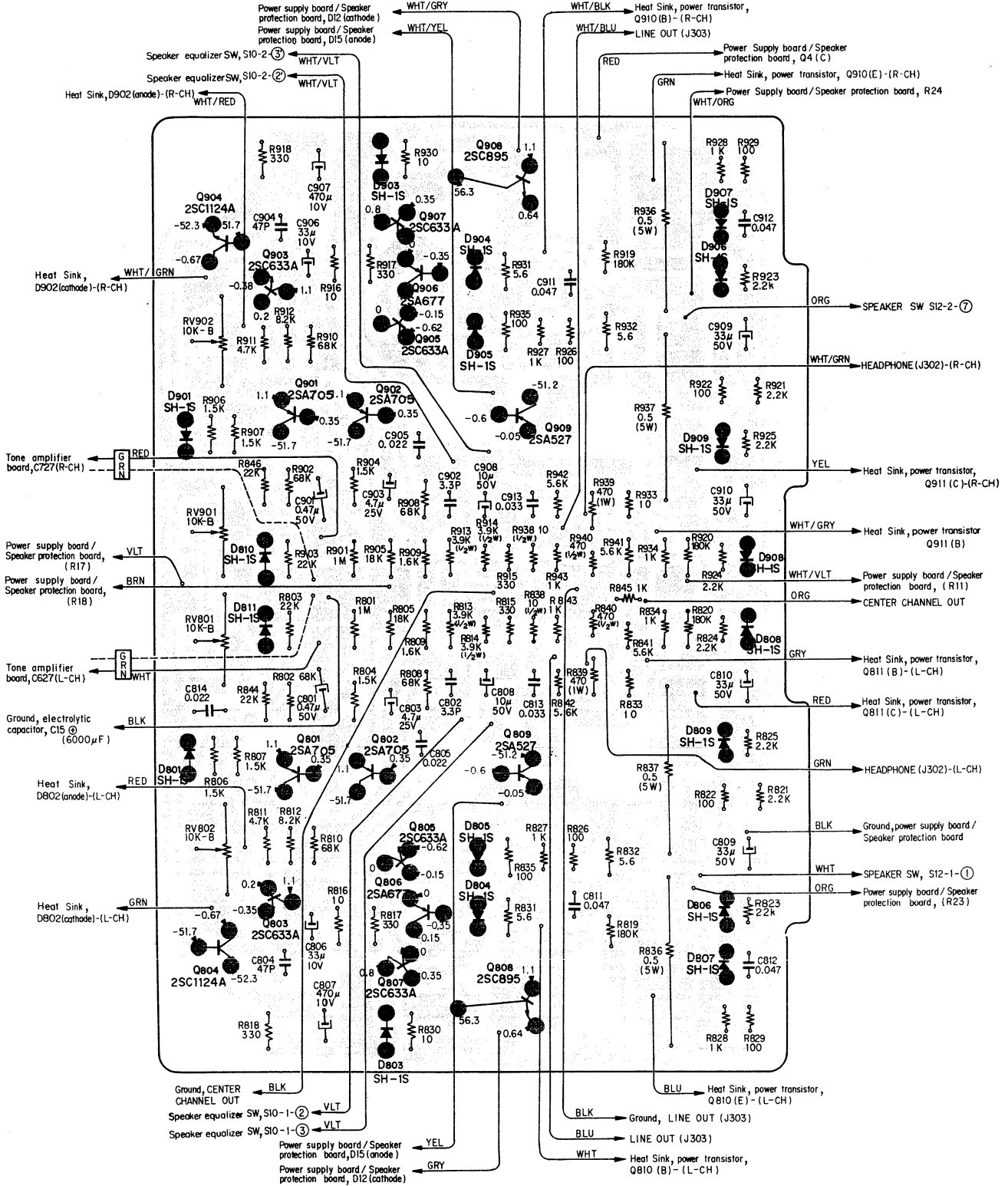

- Component Side -

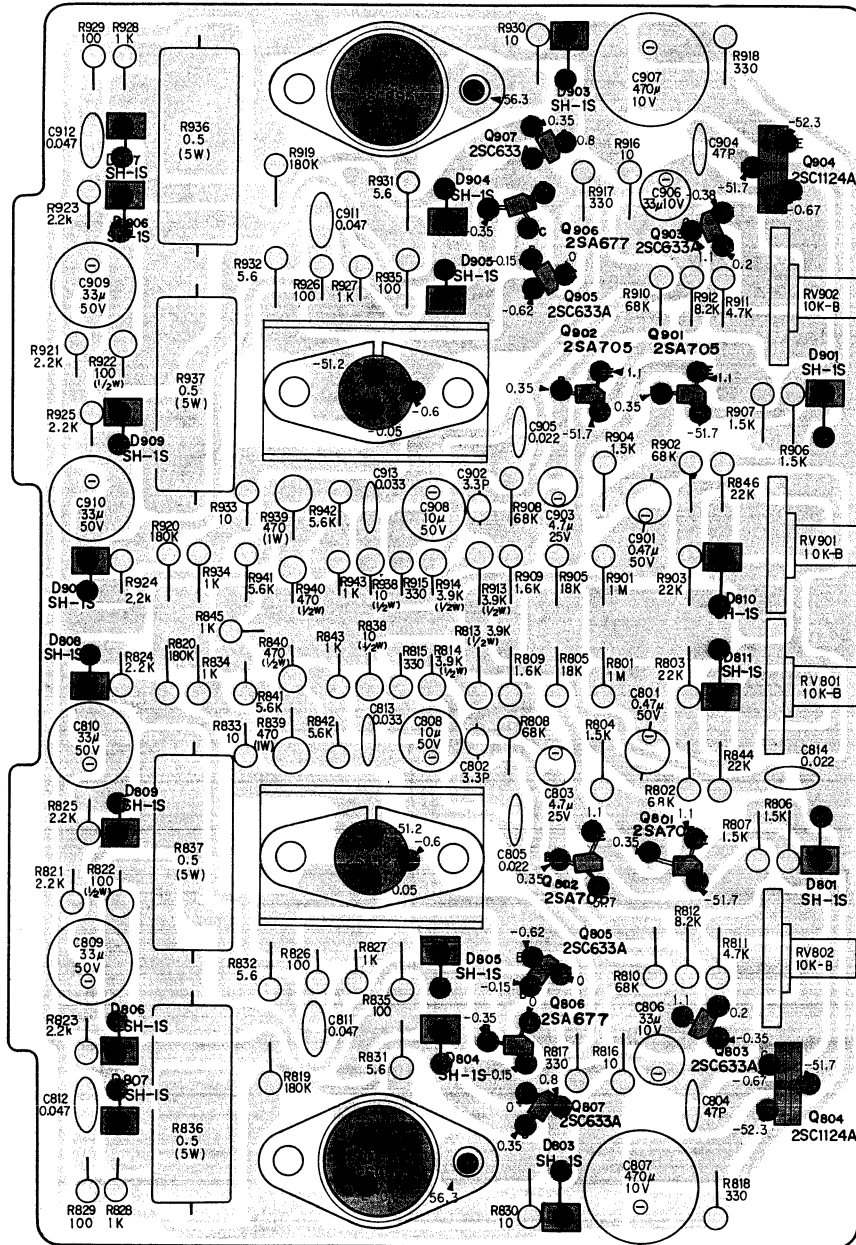

MOUNTING DIAGRAM – Power Supply Board –

– Conductor Side –

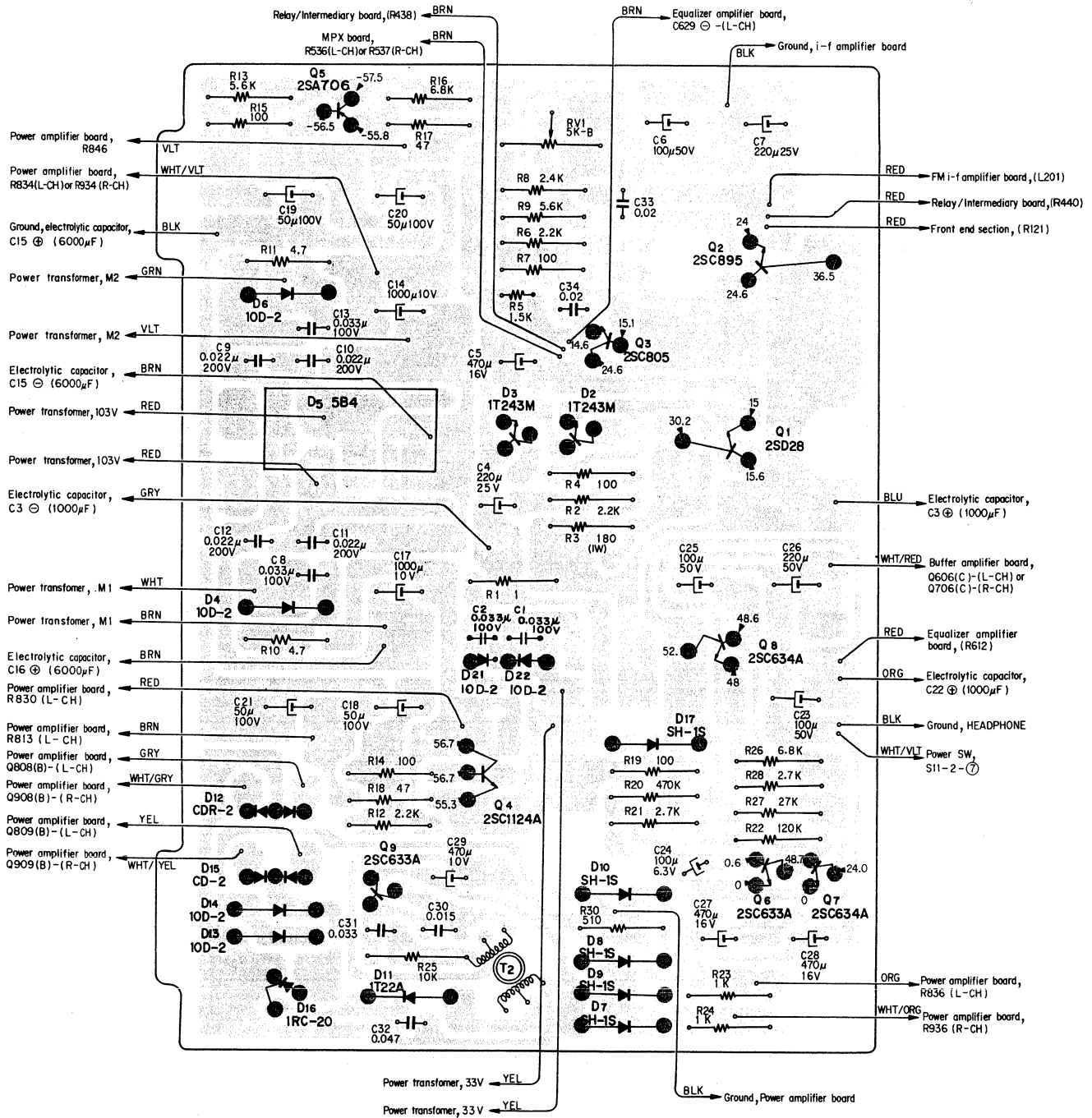

— Component Side —

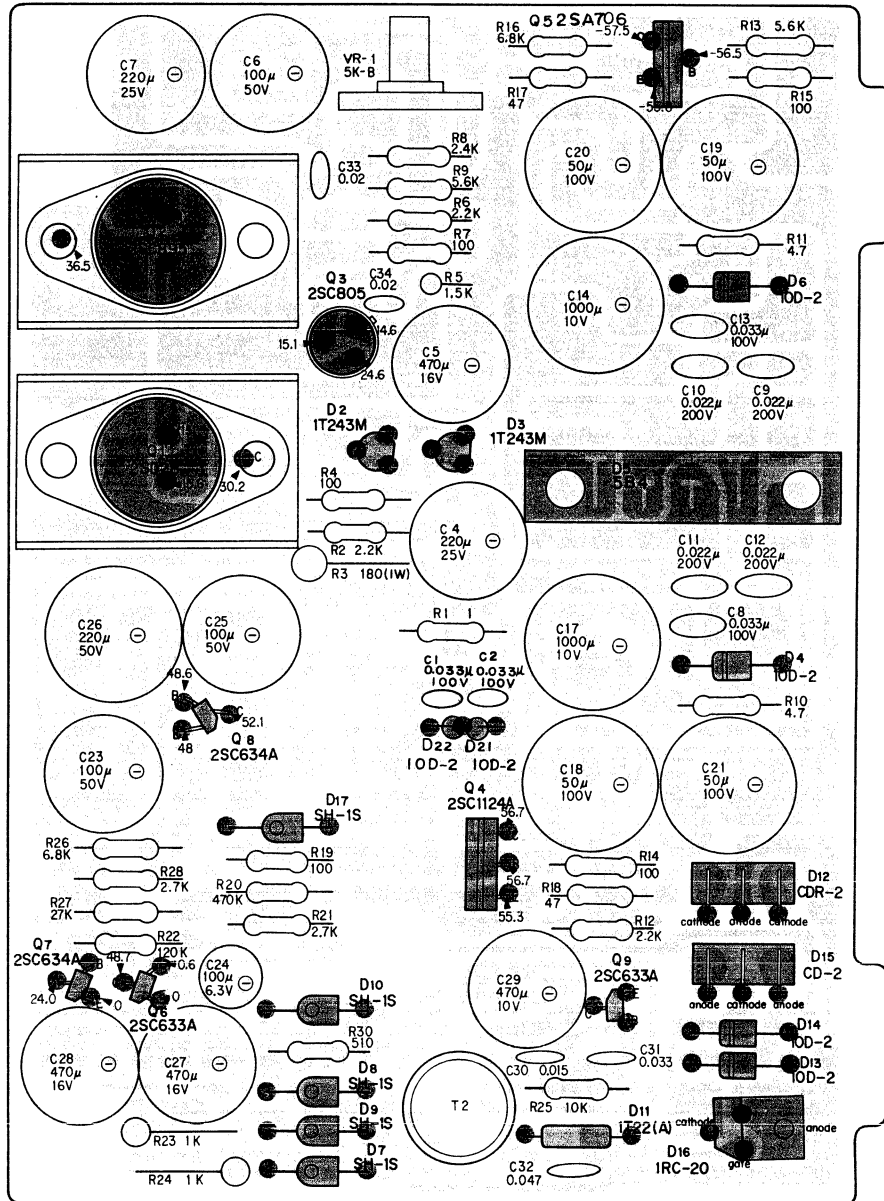

MOUNTING DIAGRAM — Relay/Intermediary Board —

— Conductor Side —

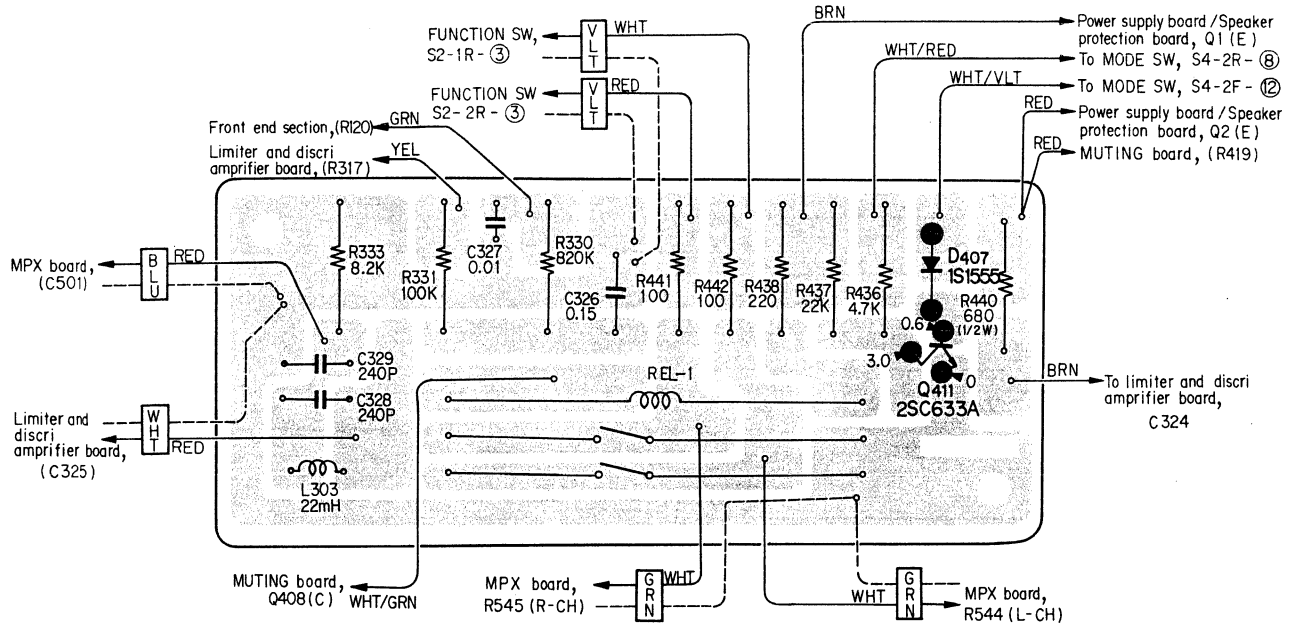

— Component Side —

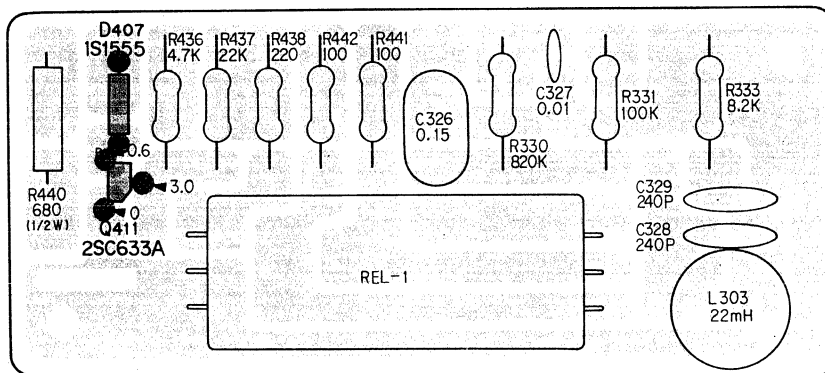

STR-6200F STR-6200F

SCHMATIC DIAGRAM – Tuner Section –

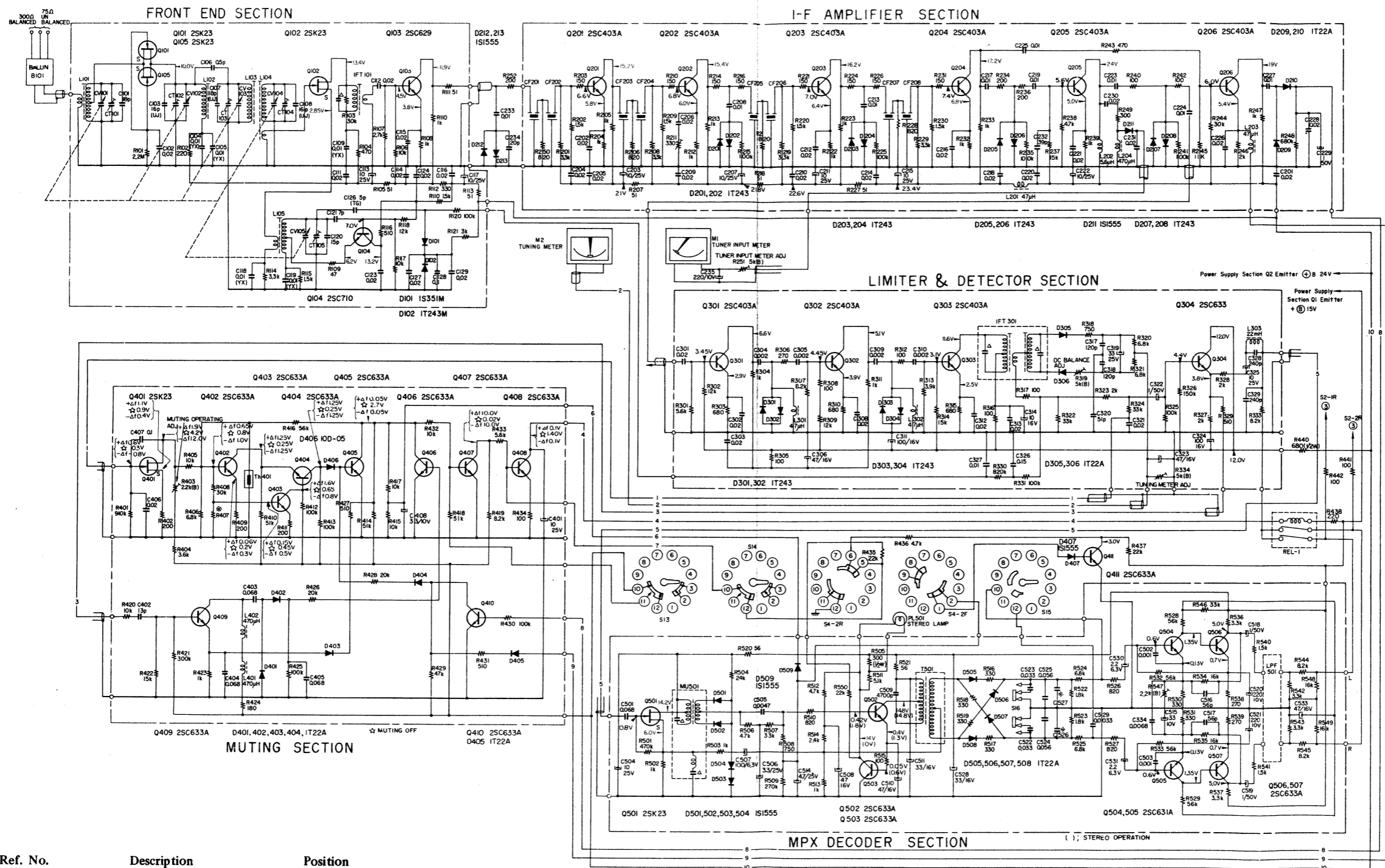

Ref. No.	Description	Position
S4	MODE SW (CHECK "L" - CHECK "R" - REVERSE - STEREO - L+R - LEFT - RIGHT)	L+R
S13	MUTING SW	ON
S14	FM MODE SW (AUTO ST - ST ONLY)	ST ONLY
S15	HIGH BLEND SW	OFF
S16	DE-EMPHASIS SW (50 μsec - 75 μsec)	75 μsec

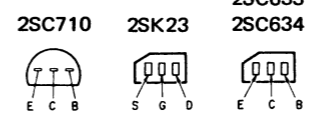
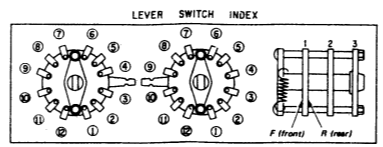
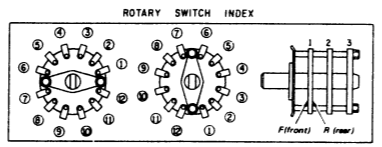

Note:
 All resistance values are in ohms. k=1,000, M=1,000k
 All capacitance values are in μF except as indicated with p, which means pF.
 All voltages represent an average value and should hold within ±20%.
 All voltages are dc measured with a VOM which has an input impedance of 20k ohms/volt. No signal in.

SONY
STR-6200F
 © 1970

STR-6200F STR-6200F

SCHEMATIC DIAGRAM — Audio Section —

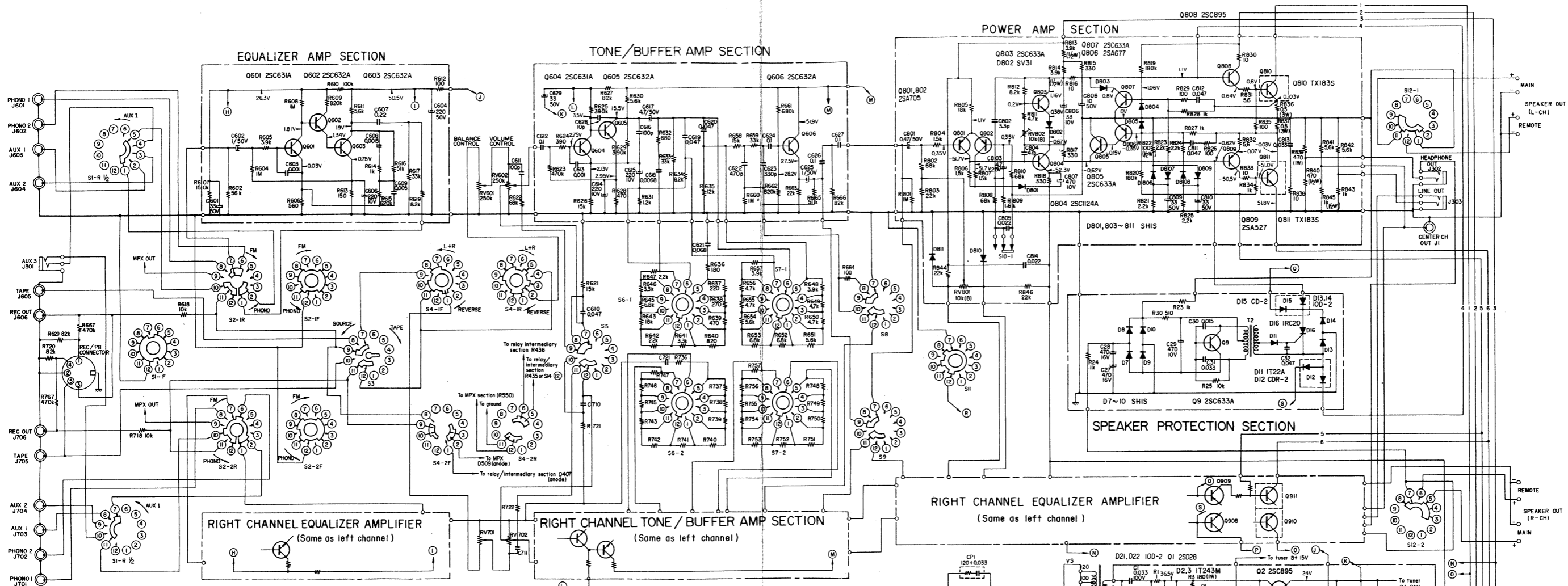

Ref. No.	Description	Position
S1	FUNCTION (1) SW (PHONO 2 - AUX 1 - AUX 2 - AUX 3)	PHONO 2
S2	FUNCTION (2) SW (FM - FUNCTION (1) - PHONO 1)	FUNCTION (1)
S3	MONITOR SW (SOURCE - TAPE)	SOURCE
S4	MODE SW (CHECK "L" - CHECK "R" - REVERSE - STEREO - L+R - LEFT - RIGHT)	STEREO
S5	LOUDNESS SW	ON
S6	TREBLE CONTROL	0dB
S7	BASS CONTROL	0dB
S8	HIGH FILTER	OFF
S9	LOW FILTER	OFF
S10	SPEAKER EQU. SW	OFF

Ref. No.	Description	Position
S11	POWER SW	OFF
S12	SPEAKER SW (REMOTE - OFF - MAIN - BOTH)	MAIN

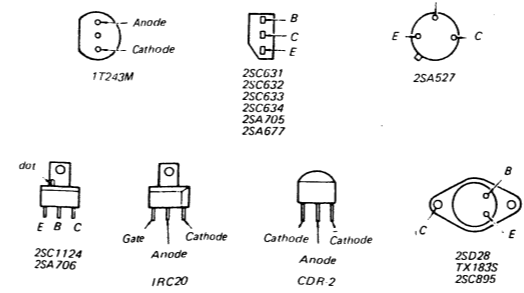
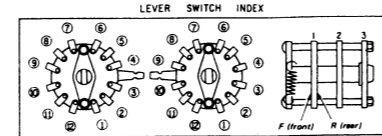
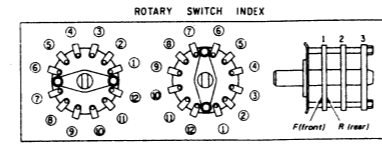

Note:
 All resistance values are in ohms. k = 1,000, M = 1,000k
 All capacitance values are in μ F except as indicated with p, which means μ F.
 All voltages represent an average value and should hold within $\pm 20\%$.
 All voltages are dc measured with a VOM which has an input impedance of 20k ohms/volt. No signal in.

SONY
STR-6200F
 © 1970

**SECTION 6
EXPLODED VIEW**

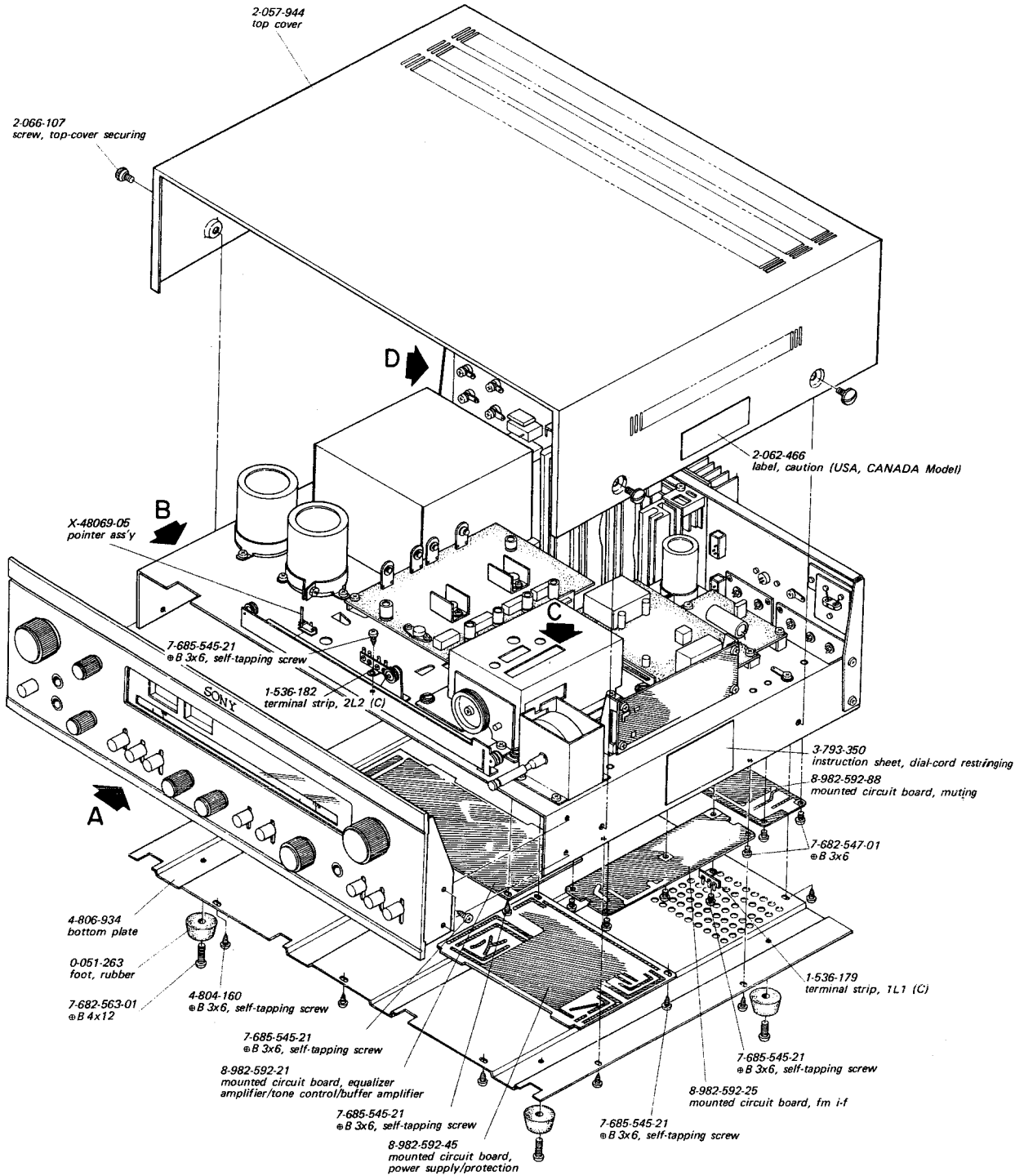

EXPLODED VIEW

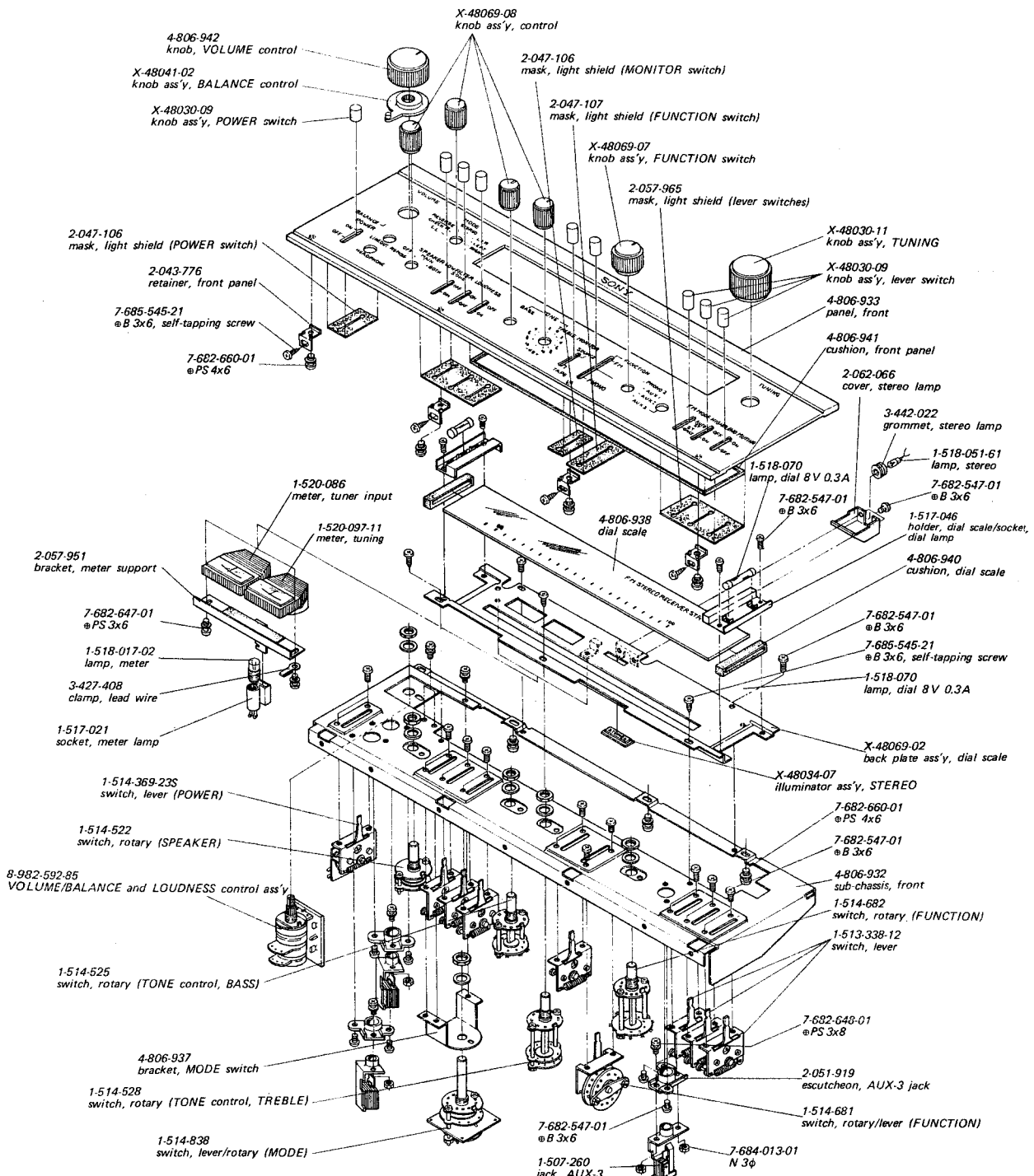

DETAIL "A" (TURN CLOCKWISE 90°)

EXPLODED VIEW

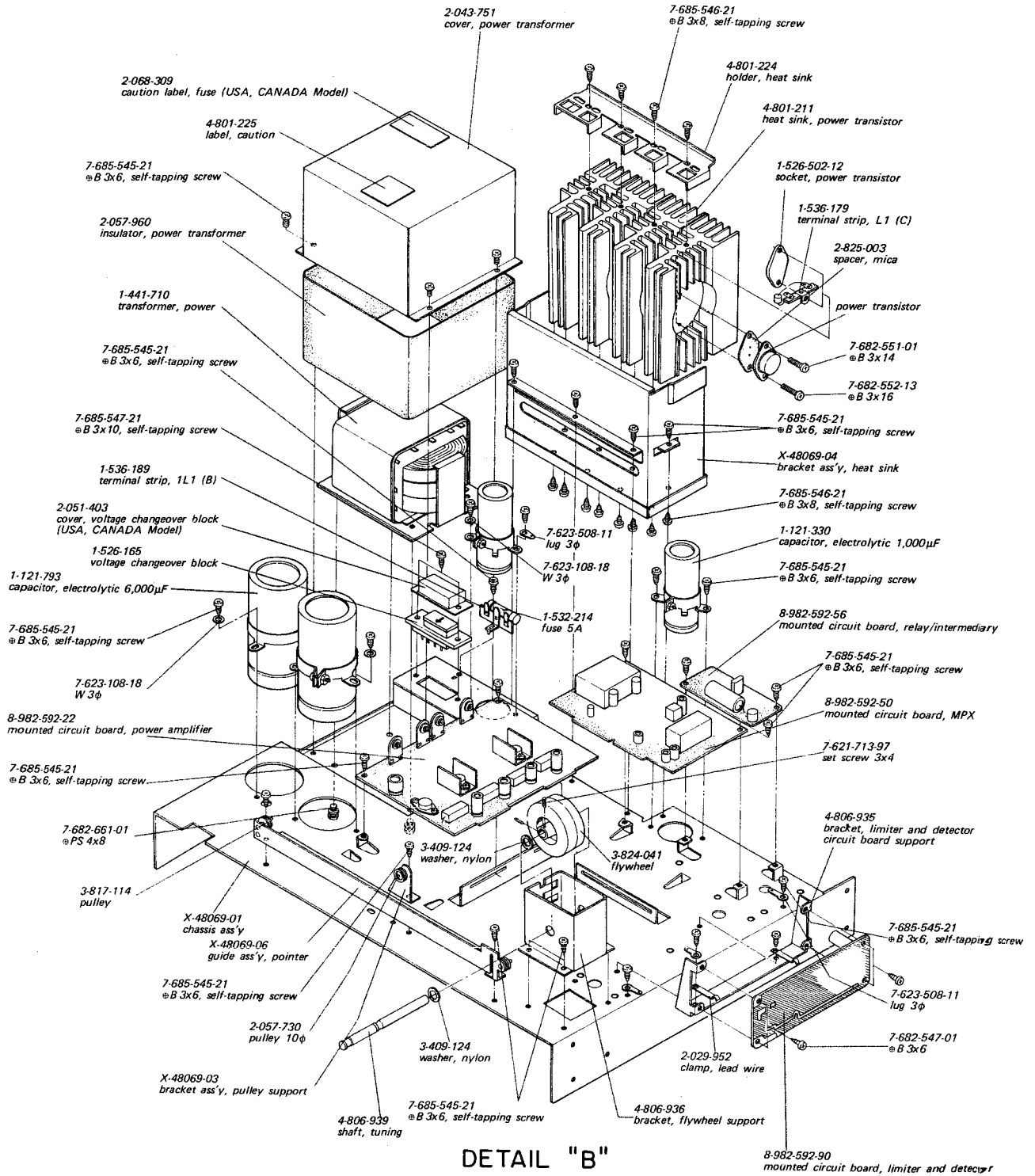

DETAIL "B"

STR-6200F

EXPLODED VIEW

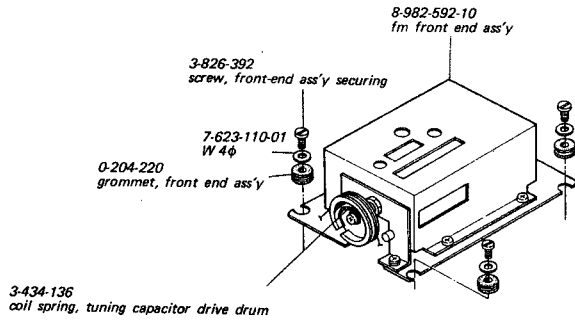

DETAIL "C"

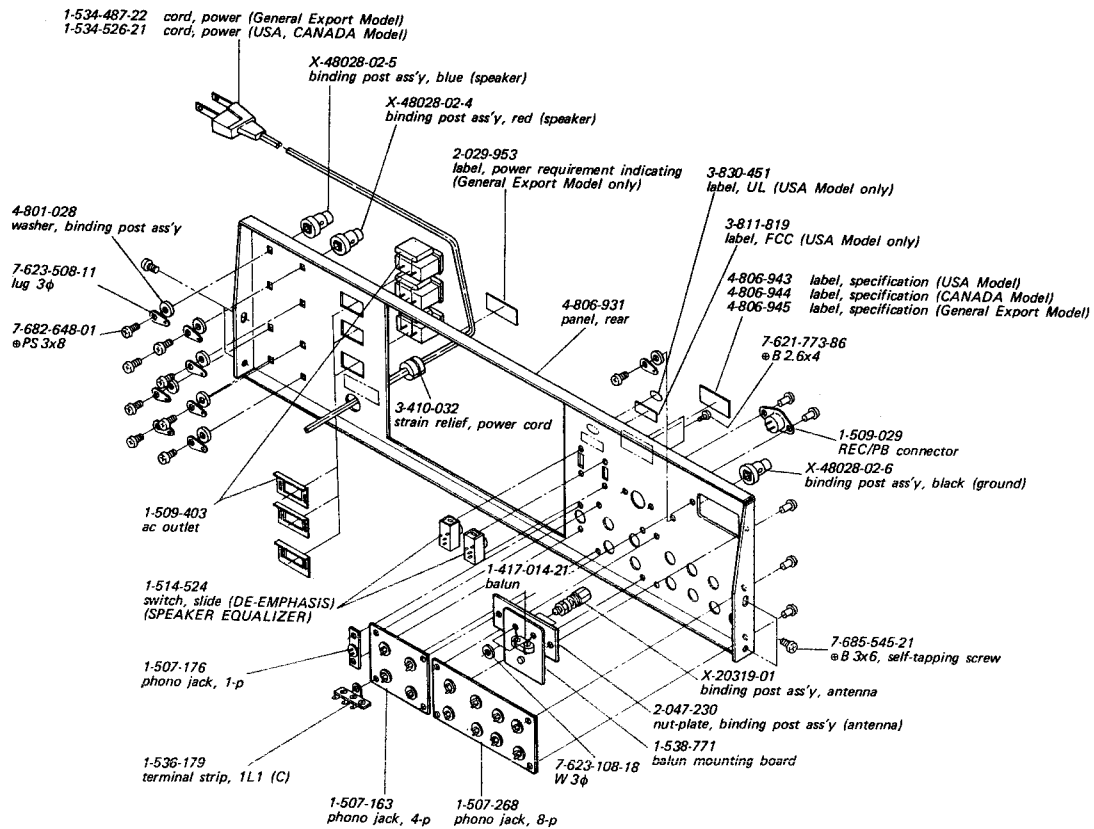

DETAIL "D"

**SECTION 7
ELECTRICAL PARTS LIST**

<u>Ref. No.</u>	<u>Part No.</u>	<u>Description</u>	<u>Ref. No.</u>	<u>Part No.</u>	<u>Description</u>
MOUNTED CIRCUIT BOARDS					
8-982-592-10		fm front end ass'y, FF-010BW	D407		diode 1S1555
8-982-592-21		equalizer amplifier/tone control/ buffer amplifier circuit board	D501		diode 1S1555
8-982-592-22		power amplifier circuit board	D502		diode 1S1555
8-982-592-25		fm i-f circuit board	D503		diode 1S1555
8-982-592-45		power supply/protection circuit board	D504		diode 1S1555
8-982-592-50		MPX circuit board	D505		diode 1T22A
8-982-592-56		relay/intermediary circuit board	D506		diode 1T22A
8-982-592-85		VOLUME/BALANCE and LOUDNESS control board	D507		diode 1T22A
8-982-592-88		muting circuit board	D508		diode 1T22A
8-982-592-90		limiter and discriminator circuit board	D509		diode 1S1555
SEMICONDUCTORS			D801 (D901)		diode SH1S
D101	diode	1S351M	D802 (D902)		varistor SV-31
D102	diode	1T243M	D803 (D903)		diode SH1S
D201	diode	1T243	D804 (D904)		diode SH1S
D202	diode	1T243	D805 (D905)		diode SH1S
D203	diode	1T243	D806 (D906)		diode SH1S
D204	diode	1T243	D807 (D907)		diode SH1S
D205	diode	1T243	D808 (D908)		diode SH1S
D206	diode	1T243	D809 (D909)		diode SH1S
D207	diode	1T243	D810		diode SH1S
D208	diode	1T243	D811		diode SH1S
D209	diode	1T22A	D2	diode	1T243M
D210	diode	1T22A	D3	diode	1T243M
D211	diode	1S1555	D4	diode	10D2
D212	diode	1S1555	D5	diode	5B4
D213	diode	1S1555	D6	diode	10D2
D301	diode	1T243	D7	diode	SH1S
D302	diode	1T243	D8	diode	SH1S
D303	diode	1T243	D9	diode	SH1S
D304	diode	1T243	D10	diode	SH1S
D305	diode	1T22A	D11	diode	1T22A
D306	diode	1T22A	D12	diode	CDR2
D401	diode	1T22A	D13	diode	10D2
D402	diode	1T22A	D14	diode	10D2
D403	diode	1T22A	D15	diode	CD2
D404	diode	1T22A	D16	SCR	1RC20
D405	diode	1T22A	D17	diode	SH1S
D406	diode	10D-05	D21 (D22)	diode	10D-2
			Th401	thermistor	S-10K
			Q101	FET	2SK23
			Q102	FET	2SK23
			Q103	transistor	2SC629
			Q104	transistor	2SC710
			Q105	FET	2SK23

<u>Ref. No.</u>	<u>Part No.</u>	<u>Description</u>
Q201	transistor	2SC403A
Q202	transistor	2SC403A
Q203	transistor	2SC403A
Q204	transistor	2SC403A
Q205	transistor	2SC403A
Q206	transistor	2SC403A
Q301	transistor	2SC403A
Q302	transistor	2SC403A
Q303	transistor	2SC403A
Q304	transistor	2SC633
Q401	FET	2SK23
Q402	transistor	2SC633A
Q403	transistor	2SC633A
Q404	transistor	2SC633A
Q405	transistor	2SC633A
Q406	transistor	2SC633A
Q407	transistor	2SC633A
Q408	transistor	2SC633A
Q409	transistor	2SC633A
Q410	transistor	2SC633A
Q411	transistor	2SC633A
Q501	FET	2SK23
Q502	transistor	2SC633A
Q503	transistor	2SC633A
Q504	transistor	2SC631A
Q505	transistor	2SC631A
Q506	transistor	2SC633A
Q507	transistor	2SC633A
Q601 (Q701)	transistor	2SC631A
Q602 (Q702)	transistor	2SC632A
Q603 (Q703)	transistor	2SC632A
Q604 (Q704)	transistor	2SC631A
Q605 (Q705)	transistor	2SC632A
Q606 (Q706)	transistor	2SC632A
Q801 (Q901)	transistor	2SA705
Q802 (Q902)	transistor	2SA705
Q803 (Q903)	transistor	2SC633A
Q804 (Q904)	transistor	2SC1124A
Q805 (Q905)	transistor	2SC633A
Q806 (Q906)	transistor	2SA677
Q807 (Q907)	transistor	2SC633A
Q808 (Q908)	transistor	2SC895
Q809 (Q909)	transistor	2SA527
Q810 (Q910)	transistor	TX-183S

<u>Ref. No.</u>	<u>Part No.</u>	<u>Description</u>
Q811 (Q911)	transistor	TX-183S
Q1	transistor	2SD28
Q2	transistor	2SC895
Q3	transistor	2SC805
Q4	transistor	2SC1124A
Q5	transistor	2SA706
Q6	transistor	2SC633A
Q7	transistor	2SC634A
Q8	transistor	2SC634A
Q9	transistor	2SC633A

TRANSFORMERS, COILS AND INDUCTORS

B101	1-417-014	balun
IFT101	1-403-295	IFT, fm
IFT301	1-403-291	transformer, discriminator
L101	1-401-368	coil, fm antenna
L102	1-425-514	coil, fm rf
L103	1-425-515	coil, fm rf
L104	1-425-516	coil, fm rf
L105	1-405-375	coil, fm osc.
L201	1-407-165	inductor, micro 47 μ H
L202	1-407-187	inductor, micro 5.6 μ H
L203	1-407-165	inductor, micro 47 μ H
L204	1-407-177	inductor, micro 470 μ H
L301	1-407-165	inductor, micro 47 μ H
L302	1-407-165	inductor, micro 47 μ H
L303	1-407-408	inductor, micro 22 mH
L401	1-407-177	inductor, micro 470 μ H
L402	1-407-177	inductor, micro 470 μ H
MU501	1-425-548	MPX unit
T1	1-441-710	transformer, power
T2	1-433-132	transformer, osc.
T501	1-425-260	transformer, switching 38 kHz

CAPACITORS

All capacitance values are in μ F except as indicated with p, which means μ μ F.

C101	1-102-893	18p (UJ) $\pm 5\%$	50V ceramic
C102	1-101-073	0.02 $\pm \frac{80}{20}\%$	25V ceramic
C103	1-102-879	16p (UJ) $\pm 5\%$	50V ceramic
C104	1-102-077	0.01 (YX) $\pm 20\%$	50V ceramic
C105	1-102-077	0.01 (YX) $\pm 20\%$	50V ceramic
C106	1-101-936	0.5p $\pm 10\%$	500V ceramic
C107	1-102-893	18p (UJ) $\pm 5\%$	50V ceramic
C108	1-102-879	16p (UJ) $\pm 5\%$	50V ceramic
C109	1-102-077	0.01 (YX) $\pm 20\%$	50V ceramic
C110		- included in IFT101 -	
C111	1-101-073	0.02 $\pm \frac{80}{20}\%$	25V ceramic

<u>Ref. No.</u>	<u>Part No.</u>	<u>Description</u>		<u>Ref. No.</u>	<u>Part No.</u>	<u>Description</u>	
C112	1-101-073	0.02	$\pm 80\%$ 25 V ceramic	C231	1-101-073	0.02	$\pm 80\%$ 25 V ceramic
C113	1-121-472	10	$\pm 100\%$ 25 V electrolytic	C232	1-101-876	39p	$\pm 5\%$ 50V ceramic
C114	1-101-073	0.02	$\pm 80\%$ 25 V ceramic	C233	1-101-072	0.01	$\pm 20\%$ 25 V ceramic
C115	1-101-073	0.02	$\pm 80\%$ 25 V ceramic	C234	1-101-864	20p	$\pm 5\%$ 50V ceramic
C116	1-101-073	0.02	$\pm 80\%$ 25 V ceramic	C235	1-121-420	220	$\pm 100\%$ 10V electrolytic
C117	1-121-472	10	$\pm 100\%$ 25 V electrolytic	C301	1-101-073	0.02	$\pm 80\%$ 25 V ceramic
C118	1-102-077	0.01 (YX)	$\pm 20\%$ 50V ceramic	C302	1-101-073	0.02	$\pm 80\%$ 25V ceramic
C119	1-102-077	0.01 (YX)	$\pm 20\%$ 50V ceramic	C303	1-101-073	0.02	$\pm 80\%$ 25V ceramic
C120	1-102-874	15 p	$\pm 5\%$ 50V ceramic	C304	1-101-919	0.002	$\pm 80\%$ 25V ceramic
C121	1-102-875	7 p	± 0.5 pF 50V ceramic	C305	1-101-919	0.002	$\pm 80\%$ 25V ceramic
C123	1-101-073	0.02	$\pm 80\%$ 25 V ceramic	C306	1-121-409	47	$\pm 100\%$ 16V electrolytic
C124	1-101-073	0.02	$\pm 80\%$ 25 V ceramic	C308	1-101-073	0.02	$\pm 80\%$ 25 V ceramic
C126	1-102-872	5 p(TG)	± 0.5 pF 50 V ceramic	C309	1-101-919	0.002	$\pm 80\%$ 25V ceramic
C127	1-101-073	0.02	$\pm 80\%$ 25 V ceramic	C310	1-101-919	0.002	$\pm 80\%$ 25V ceramic
C128	1-105-685-12	0.1	$\pm 10\%$ 50V mylar	C311	1-121-415	100	$\pm 100\%$ 16V electrolytic
C129	1-101-073	0.02	$\pm 80\%$ 25 V ceramic	C312	1-101-073	0.02	$\pm 80\%$ 25V ceramic
C201	1-101-073	0.02	$\pm 80\%$ 25 V ceramic	C313	1-101-073	0.02	$\pm 80\%$ 25 V ceramic
C202	1-101-073	0.02	$\pm 80\%$ 25 V ceramic	C314	1-121-471	10	$\pm 100\%$ 16 V electrolytic
C203	1-121-398	10	$\pm 100\%$ 25 V electrolytic	C315			- included in IFT301 -
C204	1-101-073	0.02	$\pm 80\%$ 25 V ceramic	C316			
C205	1-101-073	0.02	$\pm 80\%$ 25 V ceramic	C317	1-103-603	120p	$\pm 5\%$ 50V styrol
C206	1-101-073	0.02	$\pm 80\%$ 25 V ceramic	C318	1-103-603	120p	$\pm 5\%$ 50V styrol
C207	1-121-398	10	$\pm 100\%$ 25 V electrolytic	C319	1-121-404	33	$\pm 100\%$ 25 V electrolytic
C208	1-101-072	0.01	$\pm 80\%$ 25 V ceramic	C320	1-101-882	51 p	$\pm 5\%$ 50V ceramic
C209	1-101-073	0.02	$\pm 80\%$ 25 V ceramic	C321	1-101-073	0.02	$\pm 80\%$ 25 V ceramic
C210	1-101-073	0.02	$\pm 80\%$ 25 V ceramic	C322	1-121-391	1	$\pm 150\%$ 50V electrolytic
C211	1-121-398	10	$\pm 100\%$ 25 V electrolytic	C323	1-121-409	47	$\pm 100\%$ 16 V electrolytic
C212	1-101-073	0.02	$\pm 80\%$ 25 V ceramic	C324	1-121-415	100	$\pm 100\%$ 16 V electrolytic
C213	1-101-072	0.01	$\pm 80\%$ 25 V ceramic	C325	1-121-398	10	$\pm 100\%$ 25 V electrolytic
C214	1-101-073	0.02	$\pm 80\%$ 25 V ceramic	C326	1-105-687-12	0.15	$\pm 10\%$ 50V mylar
C215	1-121-398	10	$\pm 100\%$ 25 V electrolytic	C327	1-105-673-12	0.01	$\pm 10\%$ 50V mylar
C216	1-101-073	0.02	$\pm 80\%$ 25 V ceramic	C328	1-107-140	240p	$\pm 10\%$ 50V silver mica
C217	1-101-072	0.01	$\pm 80\%$ 25 V ceramic	C329	1-107-140	240p	$\pm 10\%$ 50V silver mica
C218	1-101-073	0.02	$\pm 80\%$ 25 V ceramic	C334	1-105-671-12	0.0068	$\pm 10\%$ 50V mylar
C219	1-101-072	0.01	$\pm 80\%$ 25 V ceramic	C401	1-121-398	10	$\pm 100\%$ 25 V electrolytic
C220	1-101-073	0.02	$\pm 80\%$ 25 V ceramic	C402	1-101-269	13p	$\pm 5\%$ 50V ceramic
C221	1-101-073	0.02	$\pm 80\%$ 25 V ceramic	C403	1-105-683-12	0.068	$\pm 10\%$ 50V mylar
C222	1-121-398	10	$\pm 100\%$ 25 V electrolytic	C404	1-105-683-12	0.068	$\pm 10\%$ 50V mylar
C223	1-101-072	0.01	$\pm 80\%$ 25 V ceramic	C405	1-105-683-12	0.068	$\pm 10\%$ 50V mylar
C224	1-101-072	0.01	$\pm 80\%$ 25 V ceramic	C406	1-101-073	0.02	$\pm 80\%$ 25 V ceramic
C225	1-101-072	0.01	$\pm 80\%$ 25 V ceramic	C407	1-105-685-12	0.1	$\pm 10\%$ 50V mylar
C226	1-101-073	0.02	$\pm 80\%$ 25 V ceramic	C408	1-121-402	33	$\pm 100\%$ 10V electrolytic
C227	1-101-072	0.01	$\pm 80\%$ 25 V ceramic	C501	1-105-683-12	0.068	$\pm 10\%$ 50V mylar
C228	1-101-073	0.02	$\pm 80\%$ 25 V ceramic	C502	1-105-661-12	0.001	$\pm 10\%$ 50V mylar
C229	1-121-391	1	$\pm 150\%$ 50V electrolytic	C503	1-105-661-12	0.001	$\pm 10\%$ 50V mylar
C230	1-101-073	0.02	$\pm 80\%$ 25 V ceramic				

STR-6200F

<u>Ref. No.</u>	<u>Part No.</u>	<u>Description</u>		<u>Ref. No.</u>	<u>Part No.</u>	<u>Description</u>	
C504	1-121-398	10	$\pm 100\%$ 25 V electrolytic	C613 (C713)	1-105-661-12	0.001	$\pm 10\%$ 50 V mylar
C505	1-105-669-12	0.0047	$\pm 10\%$ 50 V mylar	C614 (C714)	1-121-420	220	$\pm 100\%$ 10 V electrolytic
C506	1-121-392	3.3	$\pm 150\%$ 25 V electrolytic	C615 (C715)	1-121-420	220	$\pm 100\%$ 10 V electrolytic
C507	1-121-413	100	$\pm 100\%$ 6.3 V electrolytic	C616 (C716)	1-107-131	100p	$\pm 10\%$ 50 V silvered mica
C508	1-121-409	47	$\pm 100\%$ 16 V electrolytic	C617 (C717)	1-121-396	4.7	$\pm 100\%$ 50 V electrolytic
C509	1-103-575	4,700p	$\pm 5\%$ 50 V styrol	C618 (C718)	1-105-671-12	0.0068	$\pm 10\%$ 50 V mylar
C510	1-121-409	47	$\pm 100\%$ 16 V electrolytic	C619 (C719)	1-105-681-12	0.047	$\pm 10\%$ 50 V mylar
C511	1-121-403	33	$\pm 100\%$ 16 V electrolytic	C620 (C720)	1-105-681-12	0.047	$\pm 10\%$ 50 V mylar
C512)		- included in MU501 -		C621 (C721)	1-105-683-12	0.068	$\pm 10\%$ 50 V mylar
C513)				C622 (C722)	1-107-244	470p	$\pm 10\%$ 50 V silvered mica
C514	1-121-395	4.7	$\pm 150\%$ 25 V electrolytic	C623 (C723)	1-107-143	330p	$\pm 10\%$ 50 V silvered mica
C515	1-121-402	33	$\pm 100\%$ 10 V electrolytic	C624 (C724)	1-105-685-12	0.1	$\pm 10\%$ 50 V mylar
C516	1-101-884	56p	$\pm 5\%$ 50 V ceramic	C625 (C725)	1-121-391	1	$\pm 150\%$ 50 V electrolytic
C517	1-101-884	56p	$\pm 5\%$ 50 V ceramic	C626 (C726)	1-105-687-12	0.15	$\pm 10\%$ 50 V mylar
C518	1-121-391	1	$\pm 150\%$ 50 V electrolytic	C627 (C727)	1-105-685-12	0.1	$\pm 10\%$ 50 V mylar
C519	1-121-391	1	$\pm 150\%$ 50 V electrolytic	C628 (C728)	1-102-947	10p	$\pm 5\%$ 50 V ceramic
C520	1-121-420	220	$\pm 100\%$ 10 V electrolytic	C629	1-121-405	33.	$\pm 100\%$ 50 V electrolytic
C521	1-121-420	220	$\pm 100\%$ 10 V electrolytic	C801 (C901)	1-121-726	0.47	$\pm 150\%$ 50 V electrolytic
C522	1-105-679-12	0.033	$\pm 10\%$ 50 V mylar	C802 (C902)	1-107-044	3.3 p	± 0.5 pF 50 V silvered mica
C523	1-105-679-12	0.033	$\pm 10\%$ 50 V mylar	C803 (C903)	1-121-395	4.7	$\pm 150\%$ 25 V electrolytic
C524	1-105-682-12	0.056	$\pm 10\%$ 50 V mylar	C804 (C904)	1-107-015	47 p	$\pm 10\%$ 50 V silvered mica
C525	1-105-682-12	0.056	$\pm 10\%$ 50 V mylar	C805 (C905)	1-105-677-12	0.022	$\pm 10\%$ 50 V mylar
× C526	{ 1-105-673-12	0.01	$\pm 10\%$ 50 V mylar	C806 (C906)	1-121-402	33	$\pm 100\%$ 10 V electrolytic
	{ 1-105-671-12	0.0068	$\pm 10\%$ 50 V mylar	C807 (C907)	1-121-425	470	$\pm 100\%$ 10 V electrolytic
	{ 1-105-670-12	0.0056	$\pm 10\%$ 50 V mylar	C808 (C908)	1-121-738	10	$\pm 100\%$ 50 V electrolytic
* C527	{ 1-105-673-12	0.01	$\pm 10\%$ 50 V mylar	C809 (C909)	1-121-405	33	$\pm 100\%$ 50 V electrolytic
	{ 1-105-671-12	0.0068	$\pm 10\%$ 50 V mylar	C810 (C910)	1-121-405	33	$\pm 100\%$ 50 V electrolytic
	{ 1-105-670-12	0.0056	$\pm 10\%$ 50 V mylar	C811 (C911)	1-105-681-12	0.047	$\pm 10\%$ 50 V mylar
C528	1-121-403	33	$\pm 100\%$ 16 V electrolytic	C812 (C912)	1-105-681-12	0.047	$\pm 10\%$ 50 V mylar
C529	1-105-667-12	0.0033	$\pm 10\%$ 50 V mylar	C813 (C913)	1-105-679-12	0.033	$\pm 10\%$ 50 V mylar
C530	1-127-013	2.2	$\pm 20\%$ 6.3 V electrolytic (aluminum)	C814	1-105-757-12	0.022	$\pm 10\%$ 200 V mylar
C531	1-127-013	2.2	$\pm 20\%$ 6.3 V electrolytic (aluminum)	C1	1-105-719-12	0.033	$\pm 10\%$ 100 V mylar
C533	1-121-409	47	$\pm 100\%$ 16 V electrolytic	C2	1-105-719-12	0.033	$\pm 10\%$ 100 V mylar
C601	1-121-405	33	$\pm 100\%$ 50 V electrolytic	C3	1-121-924	1,000	$\pm 100\%$ 63 V electrolytic
C602 (C702)	1-121-391	1	$\pm 150\%$ 50 V electrolytic	C4	1-121-422	220	$\pm 100\%$ 25 V electrolytic
C603 (C703)	1-105-661-12	0.001	$\pm 10\%$ 50 V mylar	C5	1-121-426	470	$\pm 100\%$ 16 V electrolytic
C604	1-121-423	220	$\pm 100\%$ 50 V electrolytic	C6	1-121-417	100	$\pm 100\%$ 50 V electrolytic
C606 (C706)	1-121-420	220	$\pm 100\%$ 10 V electrolytic	C7	1-121-422	220	$\pm 100\%$ 25 V electrolytic
C607 (C707)	1-105-689-12	0.22	$\pm 10\%$ 50 V mylar	C8	1-105-719-12	0.033	$\pm 10\%$ 100 V mylar
C608 (C708)	1-106-005-12	0.0015	$\pm 5\%$ 50 V mylar	C9	1-105-757-12	0.022	$\pm 10\%$ 200 V mylar
C609 (C709)	1-106-018-12	0.0051	$\pm 5\%$ 50 V mylar	C10	1-105-757-12	0.022	$\pm 10\%$ 200 V mylar
C610 (C710)	1-105-681-12	0.047	$\pm 10\%$ 50 V mylar	C11	1-105-757-12	0.022	$\pm 10\%$ 200 V mylar
C611 (C711)	1-107-085	100p	$\pm 5\%$ 50 V silvered mica	C12	1-105-757-12	0.022	$\pm 10\%$ 200 V mylar
C612 (C712)	1-105-685-12	0.1	$\pm 10\%$ 50 V mylar	C13	1-105-719-12	0.033	$\pm 10\%$ 100 V mylar
				C14	1-121-736	1,000	$\pm 100\%$ 10 V electrolytic
				C15	1-121-925	6,000	$\pm 100\%$ 80 V electrolytic
				C16	1-121-925	6,000	$\pm 100\%$ 80 V electrolytic

* to be selected

<u>Ref. No.</u>	<u>Part No.</u>	<u>Description</u>		<u>Ref. No.</u>	<u>Part No.</u>	<u>Description</u>
C17	1-121-736	1,000	$\pm 100\%$	10V electrolytic	R116	1-244-666 510
C18	1-121-559	50	$\pm 100\%$	100V electrolytic	R117	1-244-697 10k
C19	1-121-559	50	$\pm 100\%$	100V electrolytic	R118	1-244-699 12k
C20	1-121-559	50	$\pm 100\%$	100V electrolytic	R119	1-244-648 91
C21	1-121-559	50	$\pm 100\%$	100V electrolytic	R120	1-244-721 100k
C22	1-121-924	1,000	$\pm 100\%$	63V electrolytic	R121	1-244-684 3k
C23	1-121-417	100	$\pm 100\%$	50V electrolytic	R201	1-242-685 3.3k
C24	1-121-413	100	$\pm 100\%$	6.3V electrolytic	R202	1-244-677 1.5k
C25	1-121-417	100	$\pm 100\%$	50V electrolytic	R203	1-242-653 150
C26	1-121-423	220	$\pm 100\%$	50V electrolytic	R204	1-242-673 1k
C27	1-121-426	470	$\pm 100\%$	16V electrolytic	R205	1-242-673 1k
C28	1-121-426	470	$\pm 100\%$	16V electrolytic	R206	1-244-671 820
C29	1-121-425	470	$\pm 100\%$	10V electrolytic	R207	1-244-642 51
C30	1-105-675-12	0.015	$\pm 10\%$	50V mylar	R208	1-242-685 3.3k
C31	1-105-679-12	0.033	$\pm 10\%$	50V mylar	R209	1-244-677 1.5k
C32	1-105-681-12	0.047	$\pm 10\%$	50V mylar	R210	1-242-653 150
C33	1-101-073	0.02	$\pm 80\%$ $\pm 20\%$	25V ceramic	R211	1-221-986 330 (B), semi-fixed
C34	1-101-073	0.02	$\pm 80\%$ $\pm 20\%$	25V ceramic	R212	1-244-673 1k
CT101	1-141-081	ceramic trimmer, antenna		R213	1-242-673 1k	
CT102	1-141-081	ceramic trimmer, rf		R214	1-242-653 150	
CT103	1-141-081	ceramic trimmer, rf		R215	1-244-721 100k	
CT104	1-141-081	ceramic trimmer, rf		R216	1-242-653 150	
CT105	1-141-094	ceramic trimmer, osc.		R217	1-244-671 820	
CV101	1-151-189	capacitor, tuning		R218	1-244-642 51	
CV102				R219	1-242-685 3.3k	
CV103				R220	1-244-677 1.5k	
CV104				R221	1-242-653 150	
CV105				R222	1-244-673 1k	
				R223	1-244-673 1k	
				R224	1-242-653 150	
				R225	1-244-721 100k	
				R226	1-242-653 150	
				R227	1-244-642 51	
				R228	1-244-671 820	
				R229	1-242-685 3.3k	
				R230	1-244-677 1.5k	
				R231	1-242-653 150	
				R232	1-244-673 1k	
				R233	1-244-673 1k	
				R234	1-242-656 200	
				R235	1-244-721 100k	
				R236	1-242-656 200	
				R237	1-244-701 15k	
				R238	1-244-689 4.7k	
				R239	1-244-673 1k	
				R240	1-242-649 100	
				R241	1-242-721 100k	
				R242	1-242-649 100	

RESISTORS

All resistance values are in ohms, $\pm 5\%$, $\frac{1}{4}$ watts and carbon type unless otherwise indicated.

R101	1-244-753	2.2M
R102	1-244-657	220
R103	1-244-708	30k
R104	1-244-665	470
R105	1-244-642	51
R106	1-244-697	10k
R107	1-244-689	4.7k
R108	1-244-673	1k
R110	1-244-673	1k
R111	1-244-642	51
R112	1-244-661	330
R113	1-244-642	51
R114	1-244-685	3.3k
R115	1-244-677	1.5k

STR-6200F

<u>Ref. No.</u>	<u>Part No.</u>	<u>Description</u>	<u>Ref. No.</u>	<u>Part No.</u>	<u>Description</u>
R243	1-244-665	470	R404	1-244-686	3.6k
R244	1-244-708	30k	R405	1-244-697	10k
R245	1-242-698	11k	R406	1-244-693	6.8k
R246	1-244-680	2k	* R407	1-244-713	47k
R247	1-242-673	1k		1-244-714	51k
R248	1-242-741	680k		1-244-715	56k
R249	1-242-660	300	R408	1-244-708	30k
R250	1-244-671	820	R409	1-244-656	200
R251	1-221-635	5k (B), semi-fixed	R410	1-244-714	51k
R252	1-244-656	200	R411	1-244-656	200
R301	1-244-691	5.6k	R412	1-244-721	100k
R302	1-244-699	12k	R413	1-244-721	100k
R303	1-244-669	680	R414	1-244-714	51k
R304	1-244-673	1k	R415	1-244-697	10k
R305	1-244-649	100	R416	1-244-715	56k
R306	1-242-659	270	R417	1-244-697	10k
R307	1-244-695	8.2k	R418	1-244-714	51k
R308	1-244-649	100	R419	1-244-695	8.2k
R309	1-244-699	12k	R420	1-244-697	10k
R310	1-244-669	680	R421	1-244-732	300k
R311	1-244-673	1k	R422	1-244-701	15k
R312	1-242-649	100	R423	1-244-673	1k
R313	1-244-687	3.9k	R424	1-244-655	180
R314	1-244-701	15k	R425	1-244-721	100k
R315	1-244-669	680	R426	1-244-704	20k
R316	1-244-649	100	R427	1-244-666	510
R317	1-244-649	100	R428	1-244-704	20k
R318	1-244-670	750	R429	1-244-713	47k
R319	1-221-389	5k (B), semi-fixed	R430	1-244-721	100k
R320	1-244-693	6.8k	R431	1-244-666	510
R321	1-244-693	6.8k	R432	1-244-697	10k
R322	1-244-709	33k	R433	1-244-691	5.6k
R323	1-244-680	2k	R434	1-244-649	100
R324	1-244-709	33k	R435	1-244-705	22k
R325	1-244-721	100k	R436	1-244-689	4.7k
R326	1-244-725	150k	R437	1-244-705	22k
R327	1-244-680	2k	R438	1-244-657	220
R328	1-244-680	2k	R440	1-202-569	680
R329	1-244-666	510	R441	1-244-649	100
R330	1-244-743	820k	R442	1-244-649	100
R331	1-244-721	100k	R501	1-244-737	470k
R333	1-244-695	8.2k	R502	1-244-673	1k
R334	1-221-635	5k (B), semi-fixed	R503	1-244-673	1k
R401	1-244-744	910k	R504	1-244-706	24k
R402	1-244-656	200	R505	1-202-560	300
R403	1-221-997	2.2k (B), semi-fixed	R506	1-244-689	4.7k
			R507	1-244-709	33k

±10% ½W composition

±10% ½W composition

* to be selected

<u>Ref. No.</u>	<u>Part No.</u>	<u>Description</u>	<u>Ref. No.</u>	<u>Part No.</u>	<u>Description</u>
R508	1-244-670	750	R606 (R706)	1-244-667	560
R509	1-244-731	270k	R608 (R708)	1-244-745	1 M
R510	1-244-671	820	R609 (R709)	1-244-743	820k
R511	1-244-690	5.1k	R610	1-244-721	100k
R512	1-244-689	4.7k	R611 (R711)	1-244-691	5.6k
R513	1-244-673	1k	R612	1-244-649	100
R514	1-244-682	2.4k	R613 (R713)	1-244-653	150
R515	1-244-649	100	R614 (R714)	1-244-673	1k
R516	1-244-661	330	R615 (R715)	1-244-740	620k
R517	1-244-661	330	R616 (R716)	1-244-714	51k
R518	1-244-661	330	R617 (R717)	1-244-709	33k
R519	1-244-661	330	R618 (R718)	1-244-697	10k
R520	1-244-643	56	R619 (R719)	1-244-695	8.2k
R521	1-244-643	56	R620 (R720)	1-244-719	82k
R522	1-244-679	1.8k	R621 (R721)	1-242-701	15k
R523	1-244-679	1.8k	R622 (R722)	1-242-717	68k
R524	1-244-693	6.8k	R623 (R723)	1-244-737	470k
R525	1-244-693	6.8k	R624 (R724)	1-244-663	390
R526	1-244-671	820	R625 (R725)	1-242-735	390k
R527	1-244-671	820	R626 (R726)	1-244-701	15k
R528	1-244-715	56k	R627	1-242-719	82k
R529	1-244-715	56k	R628 (R728)	1-244-665	470
R530	1-244-661	330	R629 (R729)	1-244-735	390k
R531	1-244-661	330	R630 (R730)	1-244-691	5.6k
R532	1-244-715	56k	R631 (R731)	1-244-675	1.2k
R533	1-244-715	56k	R632 (R732)	1-244-669	680
R534	1-244-702	16k	R633 (R733)	1-244-709	33k
R535	1-244-702	16k	R634 (R734)	1-244-695	8.2k
R536	1-244-685	3.3k	R635 (R735)	1-244-699	12k
R537	1-244-685	3.3k	R636 (R736)	1-244-655	180
R538	1-244-659	270	R637 (R737)	1-201-992	220 ±5% 1/8 W composition
R539	1-244-659	270	R638 (R738)	1-201-398	270 ±5% 1/8 W composition
R540	1-244-677	1.5k	R639 (R739)	1-201-618	470 ±5% 1/8 W composition
R541	1-244-677	1.5k	R640 (R740)	1-201-630	820 ±5% 1/8 W composition
R542	1-244-685	3.3k	R641 (R741)	1-202-013	3.3k ±5% 1/8 W composition
R543	1-244-685	3.3k	R642 (R742)	1-202-064	22k ±5% 1/8 W composition
R544	1-244-695	8.2k	R643 (R743)	1-202-059	18k ±5% 1/8 W composition
R545	1-244-695	8.2k	R645 (R745)	1-202-031	6.8k ±5% 1/8 W composition
R546	1-244-709	33k	R646 (R746)	1-202-013	3.3k ±5% 1/8 W composition
R547	1-222-947	2.2k (B), semi-fixed	R647 (R747)	1-202-005	2.2k ±5% 1/8 W composition
R548	1-244-702	16k	R648 (R748)	1-202-017	3.9k ±5% 1/8 W composition
R549	1-244-702	16k	R649 (R749)	1-202-022	4.7k ±5% 1/8 W composition
R550	1-244-705	22k	R650 (R750)	1-202-022	4.7k ±5% 1/8 W composition
R601	1-244-725	150k	R651 (R751)	1-202-027	5.6k ±5% 1/8 W composition
R602 (R702)	1-244-715	56k	R652 (R752)	1-202-031	6.8k ±5% 1/8 W composition
R604 (R704)	1-244-745	1M	R653 (R753)	1-202-031	6.8k ±5% 1/8 W composition
R605 (R705)	1-244-687	3.9k	R654 (R754)	1-202-027	5.6k ±5% 1/8 W composition

<u>Ref. No.</u>	<u>Part No.</u>	<u>Description</u>		<u>Ref. No.</u>	<u>Part No.</u>	<u>Description</u>	
R655 (R755)	1-202-022	4.7k	±5% 1/8W composition	R836 (R936)	1-207-294	0.5	±10% 3W wire-wound
R656 (R756)	1-202-022	4.7k	±5% 1/8W composition	R837 (R937)	1-207-294	0.5	±10% 3W wire-wound
R657 (R757)	1-202-017	3.9k	±5% 1/8W composition	R838 (R938)	1-202-525	10	±5% 1/2W composition
R658 (R758)	1-244-701	15k		R839 (R939)	1-206-089	470	±10% 1W metal-oxide
R659 (R759)	1-244-709	33k		R840 (R940)	1-202-565	470	±5% 1/2W composition
R660 (R760)	1-244-745	1M		R841 (R941)	1-242-691	5.6k	
R661 (R761)	1-244-741	680k		R842 (R942)	1-242-691	5.6k	
R662 (R762)	1-244-743	820k		R843 (R943)	1-242-673	1k	
R663 (R763)	1-244-705	22k		R844	1-242-705	22k	
R664	1-244-649	100		R845	1-242-673	1k	
R665 (R765)	1-244-714	51k		R846	1-242-705	22k	
R666 (R766)	1-244-719	82k		R847	1-244-742	750k	
R667 (R767)	1-244-737	470k		R1	1-244-601	1	
R801 (R901)	1-242-745	1M		R2	1-244-681	2.2k	
R802 (R902)	1-242-717	68k		R3	1-206-084	180	±10% 1W metal-oxide
R803 (R903)	1-242-705	22k		R4	1-244-649	100	
R804 (R904)	1-242-677	1.5k		R5	1-244-677	1.5k	
R805 (R905)	1-242-703	18k		R6	1-244-681	2.2k	
R806 (R906)	1-242-677	1.5k		R7	1-244-649	100	
R807 (R907)	1-242-677	1.5k		R8	1-244-682	2.4k	
R808 (R908)	1-242-717	68k		R9	1-244-691	5.6k	
R809 (R909)	1-242-678	1.6k		R10	1-244-617	4.7	
R810 (R910)	1-242-717	68k		R11	1-244-617	4.7	
R811 (R911)	1-242-689	4.7k		R12	1-244-681	2.2k	
R812 (R912)	1-242-695	8.2k		R13	1-244-691	5.6k	
R813 (R913)	1-202-587	3.9k	±5% 1/2W composition	R14	1-244-649	100	
R814 (R914)	1-202-587	3.9k	±5% 1/2W composition	R15	1-244-649	100	
R815 (R915)	1-242-661	330		R16	1-244-693	6.8k	
R816 (R916)	1-242-625	10		R17	1-244-641	47	
R817 (R917)	1-242-661	330		R18	1-244-641	47	
R818 (R918)	1-242-661	330		R19	1-244-649	100	
R819 (R919)	1-242-727	180k		R20	1-244-737	470k	
R820 (R920)	1-242-727	180k		R21	1-244-683	2.7k	
R821 (R921)	1-242-681	2.2k		R22	1-244-723	120k	
R822 (R922)	1-202-549	100	±5% 1/2W composition	R23	1-202-776	1k	±10% composition
R823 (R923)	1-242-681	2.2k		R24	1-202-776	1k	±10% composition
R824 (R924)	1-242-681	2.2k		R25	1-244-697	10k	
R825 (R925)	1-242-681	2.2k		R26	1-244-693	6.8k	
R826 (R926)	1-242-649	100		R27	1-244-707	27k	
R827 (R927)	1-242-673	1k		R28	1-244-683	2.7k	
R828 (R928)	1-242-673	1k		R29	1-202-645	1M	±10% 1/2W composition (USA, CANADA Model only)
R829 (R929)	1-242-649	100		R30	1-244-666	510	
R830 (R930)	1-242-625	10		RV601 (701)			
R831 (R931)	1-242-619	5.6		RV602 (702)	1-222-392	250k (N), variable	
R832 (R932)	1-242-619	5.6		RV801 (901)	1-221-967	10k (B), semi-fixed	
R833 (R933)	1-242-625	10		RV802 (902)	1-221-967	10k (B), semi-fixed	
R834 (R934)	1-242-673	1k					
R835 (R935)	1-242-649	100					

<u>Ref. No.</u>	<u>Part No.</u>	<u>Description</u>		
RV1	1-221-996	5k (B), semi-fixed		
SWITCHES				
S1	1-514-682	switch, rotary (FUNCTION 1)		
S2	1-514-681	switch, lever (FUNCTION 2)		
S3	1-513-338-12	switch, lever (MONITOR)		
S4	1-514-838	switch, rotary (MODE)		
S5	1-513-338-12	switch, lever (LOUDNESS)		
S6	1-514-528	switch, rotary (TONE control, TREBLE)		
S7	1-514-525	switch, rotary (TONE control, BASS)		
S8	1-513-338-12	switch, lever (HIGH FILTER)		
S9	1-513-338-12	switch, lever (LOW FILTER)		
S10	1-514-524	switch, slide (SPEAKER EQUALIZER)		
S11	1-514-369	switch, lever (POWER)		
S12	1-514-522	switch, rotary (SPEAKER)		
S13	1-513-338-12	switch, lever (MUTING)		
S14	1-513-338-12	switch, lever (FM MODE)		
S15	1-513-338-12	switch, lever (HIGH BLEND)		
S16	1-514-524	switch, slide (DE-EMPHASIS)		
FILTERS				
		(Color)	(Specified Center Freq.)	
CF201	1-403-564-11	fm i-f, ceramic red	10.70 MHz	
CF202	1-403-564-21	fm i-f, ceramic black	10.66 MHz	
CF203				
CF204	1-403-564-31	fm i-f, ceramic white	10.74 MHz	
CF205				
CF206				
CF207	1-403-564-41	fm i-f, ceramic green	10.62 MHz	
CF208	1-403-564-51	fm i-f, ceramic yellow	10.78 MHz	

<u>Ref. No.</u>	<u>Part No.</u>	<u>Description</u>
LPF501	1-231-088	filter, low-pass
MISCELLANEOUS		
	1-231-057	encapsulated component, 120Ω+0.033μF
	1-507-163	phono jack, 4-P
	1-507-176	phono jack, 1-P
	1-507-260	jack, HEADPHONE; LINE OUT; AUX-3
	1-507-268	phono jack, 8-P
	1-509-029	REC/PB connector
	1-509-403	AC outlet
	1-515-101	relay, 12V 700Ω
	1-517-021	socket, meter lamp
	1-517-046	holder, dial scale
	1-518-017-03	lamp, meter 8V 0.15A
	1-518-051-61	lamp, stereo 4.5V 40 mA
	1-518-070	lamp, dial 8V 0.3A
	1-520-086	meter, tuner input
	1-520-097-11	meter, tuning
	1-526-165	voltage changeover block
	1-526-502	socket, transistor
	1-532-214	fuse 5A
	1-533-051	socket, dial lamp
	1-534-487	cord, power (General Export Model)
	1-534-526	cord, power (USA, CANADA Model)
	1-536-179	terminal strip, 1L1 (C)
	1-536-182	terminal strip, 2L2 (C)
	1-536-189	terminal strip, 1L1 (B)
	1-538-771	balun mounting board

CORRECTION

March, 1973

Subject: Error on Schematic Diagram on Page 54

The drawing of the IRC 20 (SCR) shows the gate and cathode leads reversed.
The correct lead arrangement is as follows:

