

# STR-AV20L

## SERVICE MANUAL

AEP Model



### SPECIFICATIONS

#### Amplifier section

Continuous RMS power output

According to DIN 45500

35 + 35 watts (8 ohms)

At 1 kHz

38 + 38 watts (1% THD, 8 ohms)

40 + 40 watts (1% THD, 4 ohms)

Harmonic distortion

Less than 0.8% at rated output

Frequency response

PHONO: RIAA equalization curve  $\pm 0.5$  dB

CD/AUX

VIDEO

TAPE

10Hz - 50kHz  $\pm 0$  dB

$\pm 3$  dB

Inputs

	Sensitivity	Impedance	S/N (weighting network, input level)
PHONO	2.5 mV	50 kilohms	74 dB 72 dB* (A. 2.5 mV)
CD/AUX VIDEO TAPE	150 mV	50 kilohms	95 dB 80 dB* (A. 150 mV)

\* '78 IHF

Outputs

REC OUT, VIDEO (AUDIO) OUT	Voltage 150 mV Impedance 10 kilohms
SPEAKERS A, B	Accepts speakers of 8 - 16 ohms
HEADPHONES	Accepts low and high impedance headphones

Tone controls

BASS:  $\pm 8$  dB at 100 Hz

TREBLE:  $\pm 8$  dB at 10 kHz

Loudness

-8 dB at 100 Hz (att. 30 dB)

	FM tuner section	MW/LW tuner section
Tuning range	87.5 - 108 MHz	MW: 531 - 1602 kHz LW: 153 - 344 kHz
Antenna terminals	300 ohms, balanced 75 ohms, unbalanced	External antenna terminal
Intermediate frequency	10.7 MHz	450 kHz
Sensitivity at 50 dB quieting	17.3 dBf, 4 $\mu$ V (mono) 38.3 dBf, 45 $\mu$ V (stereo)	—
Usable sensitivity	11.2 dBf, 2 $\mu$ V (IHF)	Layout-free antenna MW: 55 dB/m (at 1000 kHz) LW: 64 dB/m (at 230 kHz) External antenna MW: 100 $\mu$ V (at 1000 kHz) LW: 100 $\mu$ V (at 230 kHz)
Signal-to-noise ratio	76 dB (mono) 70 dB (stereo)	54 dB (at 50 mV/m)
Harmonic distortion	0.15% (mono), 0.3% (stereo) at 1 kHz	0.3% (at 50 mV/m, 400 Hz)
Selectivity	60 dB at 400 kHz	35 dB at 9 kHz
Separation	45 dB at 1 kHz	
Frequency response	40 Hz - 12.5 kHz $\pm 0.5$ dB	

— Continued on Page 2 —

#### SAFETY-RELATED COMPONENT WARNING!!

COMPONENTS IDENTIFIED BY SHADING AND MARK  ON THE SCHEMATIC DIAGRAMS AND IN THE PARTS LIST ARE CRITICAL TO SAFE OPERATION. REPLACE THESE COMPONENTS WITH SONY PARTS WHOSE PART NUMBERS APPEAR AS SHOWN IN THIS MANUAL OR IN SUPPLEMENTS PUBLISHED BY SONY.

FM STEREO/FM-AM RECEIVER  
**SONY**®



AUD

**General System**  
Tuner section: PLL quartz-locked digital synthesizer system  
Preamplifier section: low-noise NF type equalizer amp  
Power amplifier section: quasi-complementary SEPP

**Power requirements**  
220 V AC, 50 Hz

**Power consumption**  
90 watts

**AC outlets**  
Two switched (total 100 watts)

**Dimensions**  
Approx. 430 x 105 x 295 mm (w/h/d)  
(17 x 4 1/4 x 11 5/8 inches)  
including projecting parts and controls

**Weight**  
Approx. 6.0 kg (13 lbs 4 oz) net  
Approx. 7.1 kg (15 lbs 11 oz) in shipping carton

**Accessories supplied**  
FM ribbon antenna (1)  
MW/LW layout-free antenna (1)

**TABLE OF CONTENTS**

**SECTION 1 GENERAL**  
1-1. Location and Function of Controls. . . . . 3

**SECTION 2 ADJUSTMENTS** . . . . . 4

**SECTION 3 DIAGRAMS**  
3-1. Mounting Diagram. . . . . 9  
3-2. Schematic Diagram . . . . . 13

**SECTION 4 EXPLODED VIEWS AND PARTS LIST** . . . . . 18

**SECTION 5 ELECTRICAL PARTS LIST** . . . . . 21

**FEATURES**

The STR-AV20L is a combined receiver and audio/video control center. You can listen to various audio/video program sources through the amplifier of the receiver and the speakers connected to it. In the tuner section, a quartz-locked digital synthesizer system allows precise tuning.  
A total of 10 FM/MW/LW stations can be preset.

Inputs	Outputs
<b>PHONO</b> Sensitivity: 2.5 mV Impedance: 50 kilohms S/N (weighting network, input level): 74 dB 72 dB* (A, 2.5 mV)	<b>REC OUT</b> Voltage: 150 mV Impedance: 10 kilohms
<b>CD/AUX</b> Sensitivity: 180 mV Impedance: 50 kilohms S/N (weighting network, input level): 85 dB 80 dB* (A, 180 mV)	<b>VIDEO (AUDIO) OUT</b> Accepts speakers of 8 - 16 ohms
<b>VIDEO</b> Sensitivity: 180 mV Impedance: 50 kilohms S/N (weighting network, input level): 85 dB 80 dB* (A, 180 mV)	<b>SPEAKERS A, B</b> Accepts low and high impedance headphones
<b>TAPE</b> Sensitivity: 180 mV Impedance: 50 kilohms S/N (weighting network, input level): 85 dB 80 dB* (A, 180 mV)	<b>HEADPHONES</b> Accepts low and high impedance headphones

Inputs	Outputs
<b>PHONO</b> Sensitivity: 2.5 mV Impedance: 50 kilohms S/N (weighting network, input level): 74 dB 72 dB* (A, 2.5 mV)	<b>REC OUT</b> Voltage: 150 mV Impedance: 10 kilohms
<b>CD/AUX</b> Sensitivity: 180 mV Impedance: 50 kilohms S/N (weighting network, input level): 85 dB 80 dB* (A, 180 mV)	<b>VIDEO (AUDIO) OUT</b> Accepts speakers of 8 - 16 ohms
<b>VIDEO</b> Sensitivity: 180 mV Impedance: 50 kilohms S/N (weighting network, input level): 85 dB 80 dB* (A, 180 mV)	<b>SPEAKERS A, B</b> Accepts low and high impedance headphones
<b>TAPE</b> Sensitivity: 180 mV Impedance: 50 kilohms S/N (weighting network, input level): 85 dB 80 dB* (A, 180 mV)	<b>HEADPHONES</b> Accepts low and high impedance headphones

Inputs	Outputs
<b>PHONO</b> Sensitivity: 2.5 mV Impedance: 50 kilohms S/N (weighting network, input level): 74 dB 72 dB* (A, 2.5 mV)	<b>REC OUT</b> Voltage: 150 mV Impedance: 10 kilohms
<b>CD/AUX</b> Sensitivity: 180 mV Impedance: 50 kilohms S/N (weighting network, input level): 85 dB 80 dB* (A, 180 mV)	<b>VIDEO (AUDIO) OUT</b> Accepts speakers of 8 - 16 ohms
<b>VIDEO</b> Sensitivity: 180 mV Impedance: 50 kilohms S/N (weighting network, input level): 85 dB 80 dB* (A, 180 mV)	<b>SPEAKERS A, B</b> Accepts low and high impedance headphones
<b>TAPE</b> Sensitivity: 180 mV Impedance: 50 kilohms S/N (weighting network, input level): 85 dB 80 dB* (A, 180 mV)	<b>HEADPHONES</b> Accepts low and high impedance headphones

**Outputs**  
REC OUT: Voltage 150 mV, Impedance 10 kilohms  
VIDEO (AUDIO) OUT: Accepts speakers of 8 - 16 ohms  
SPEAKERS A, B: Accepts low and high impedance headphones  
HEADPHONES: Accepts low and high impedance headphones



**SECTION 1 GENERAL**

**1-1. LOCATION AND FUNCTION OF CONTROLS**

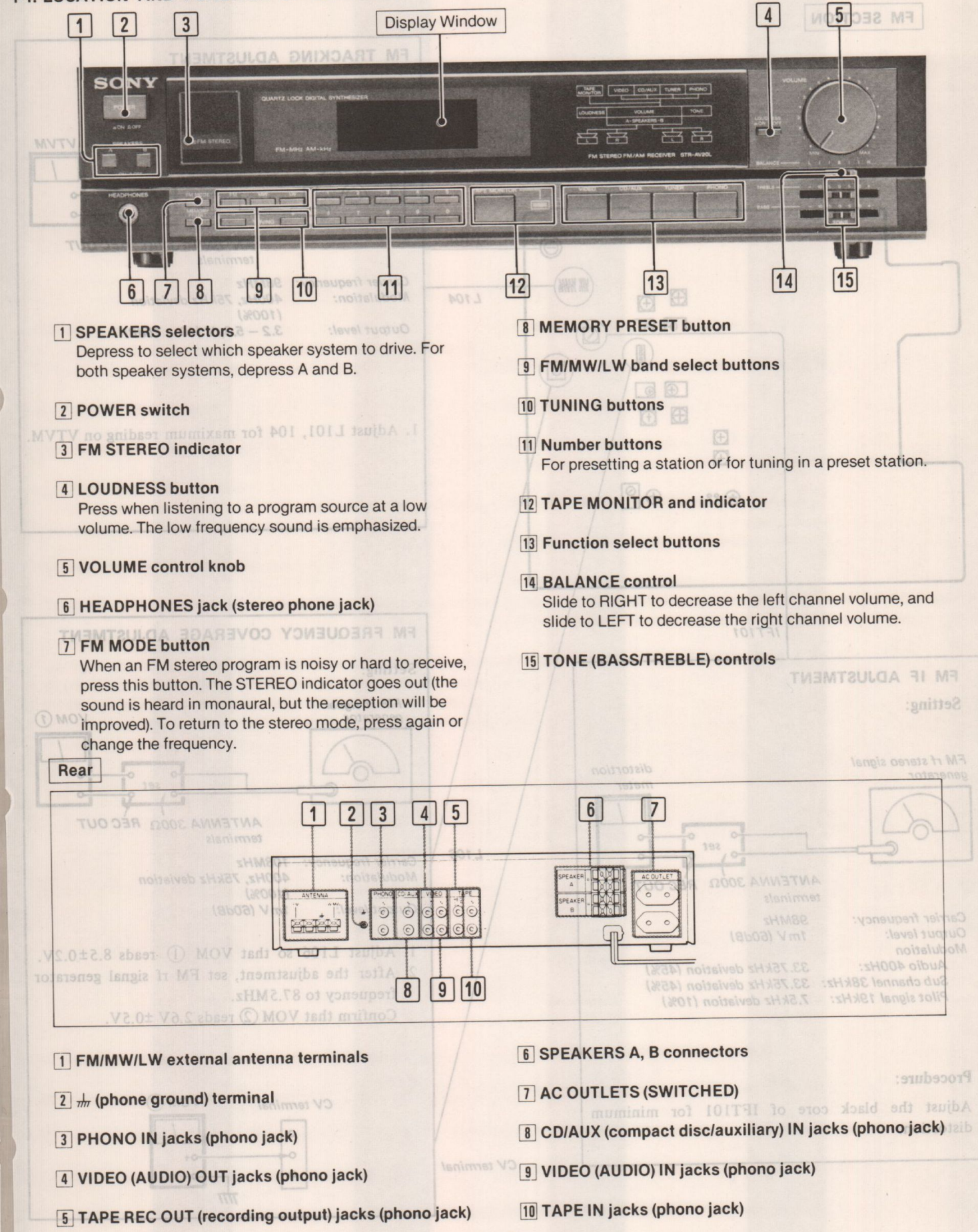

## SECTION 2 ADJUSTMENTS

### FM SECTION

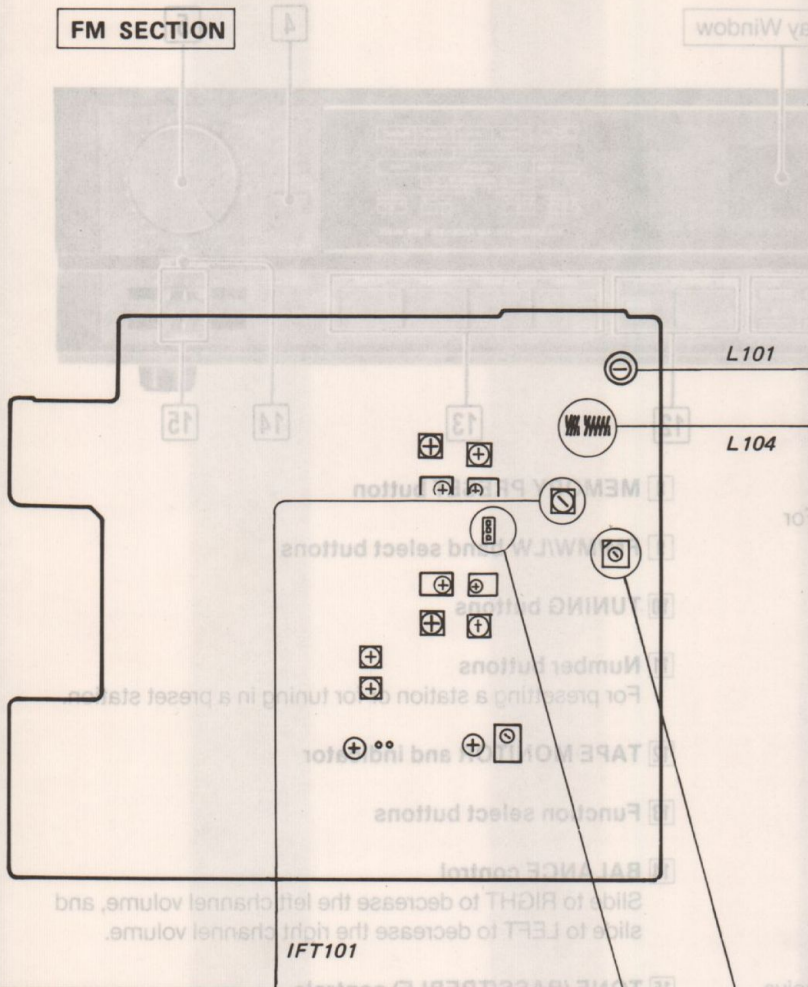

### FM TRACKING ADJUSTMENT

Setting:

FM rf stereo signal generator

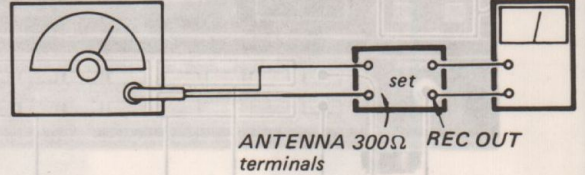

Carrier frequency: 98MHz  
 Modulation: 400Hz, 75kHz deviation (100%)  
 Output level: 3.2 - 5.3μV (10 - 15dB)

1. Adjust L101, 104 for maximum reading on VTVM.

### FM IF ADJUSTMENT

Setting:

FM rf stereo signal generator

distortion meter

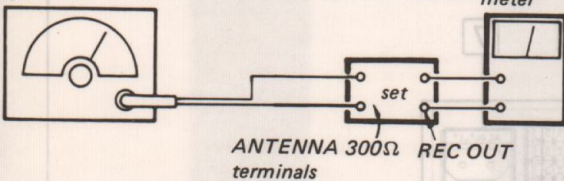

Carrier frequency: 98MHz  
 Output level: 1mV (60dB)  
 Modulation  
 Audio 400Hz: 33.75kHz deviation (45%)  
 Sub channel 38kHz: 33.75kHz deviation (45%)  
 Pilot signal 19kHz: 7.5kHz deviation (10%)

Procedure:

Adjust the black core of IFT101 for minimum distortion.

### FM FREQUENCY COVERAGE ADJUSTMENT

Setting:

FM rf signal generator

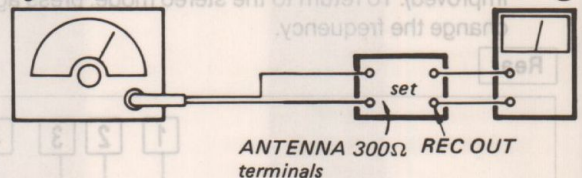

Carrier frequency: 108MHz  
 Modulation: 400Hz, 75kHz deviation (100%)  
 Output level: 1mV (60dB)

1. Adjust L106 so that VOM ① reads  $8.5 \pm 0.2V$ .
2. After the adjustment, set FM rf signal generator frequency to 87.5MHz. Confirm that VOM ② reads  $2.6V \pm 0.5V$ .

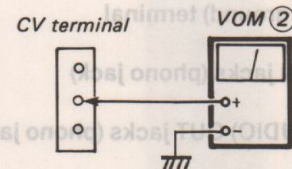

**FM Stereo Separation Adjustment**

**Procedure:**

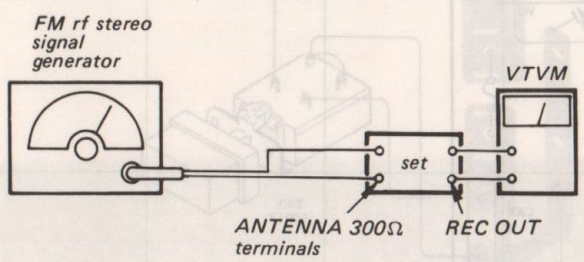

Carrier frequency: 98MHz  
 Output level: 1mV (60dB)  
 Modulation  
 Audio 400Hz: 33.75kHz deviation (45%)  
 Sub channel 38kHz: 33.75kHz deviation (45%)  
 Pilot signal 19kHz: 7.5kHz deviation (10%)

FM stereo signal generator output channel	VTVM connection	VTVM reading (dB)
L-CH	L-CH	(A)
R-CH	L-CH	Adjust RV202 for minimum reading.
R-CH	R-CH	(C)
L-CH	R-CH	Adjust RV201 for minimum reading.

L-CH Stereo separation: (A) - (B)  
 R-CH Stereo separation: (C) - (D)  
 The separations of both channels should be equal.

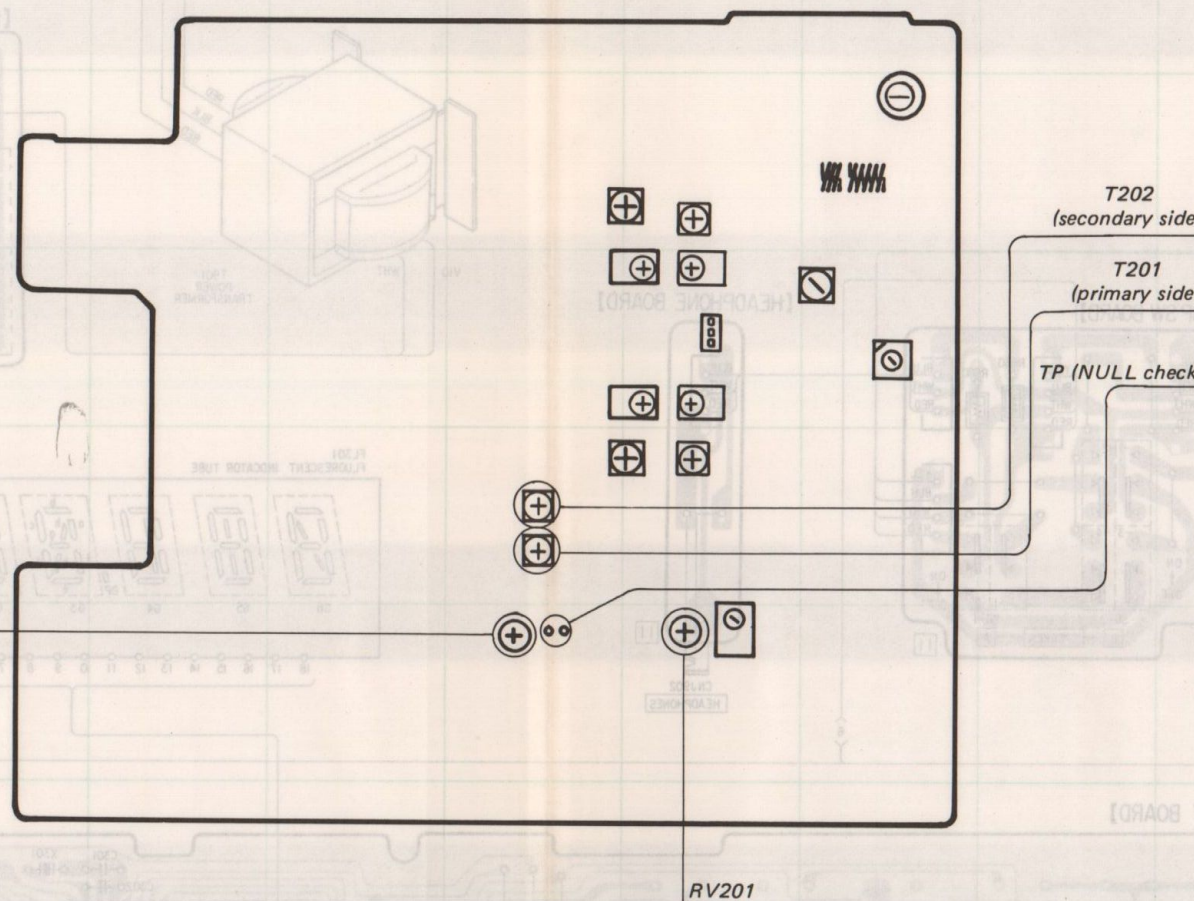

**FM Tuning Stop Adjustment**

**Setting:**

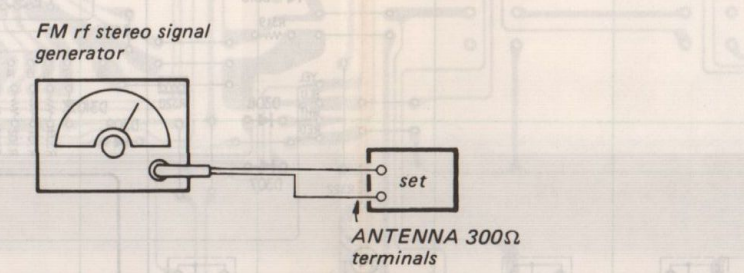

Carrier frequency: 98MHz  
 Output level: 14.3μV (23dB)  
 Modulation  
 Audio 400Hz: 33.75kHz deviation (45%)  
 Sub channel 38kHz: 33.75kHz deviation (45%)  
 Pilot signal 19kHz: 7.5kHz deviation (10%)

**Procedure:**  
 1. Tune the set to 98MHz by pressing the TUNING buttons.  
 2. Adjust RV201 so that the STEREO LED goes on.

**FM Discriminator Alignment**

**Setting:**

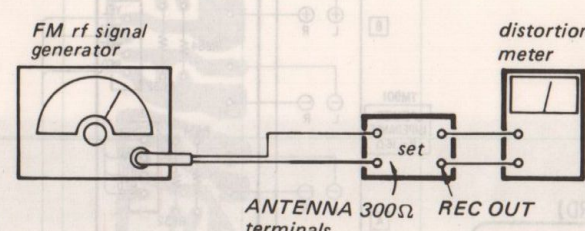

Carrier frequency: 98MHz  
 Modulation: 400Hz, 75kHz deviation (100%)  
 Output level: 1mV (60dB)

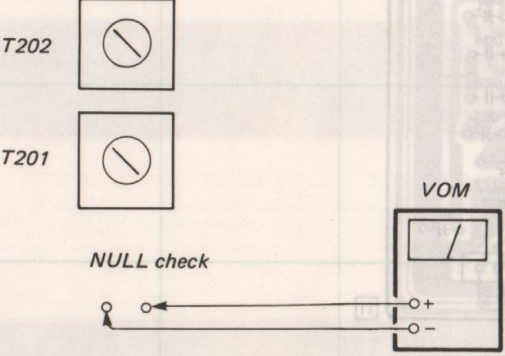

**Procedure:**  
 1. Tune the set to 98 MHz.  
 2. Adjust the green core (primary- side) of T201 for 0V reading on VOM.  
 3. Adjust the white core (secondary- side) of T202 for minimum distortion.

**Note:** When replacing the ceramic filter, perform this alignment. Repeat the secondary-side and primary-side alignments several times.

**AM SECTION**

Repeat the procedures in each adjustment several times, and the frequency coverage and tracking adjustments should be finally done by the trimmer capacitors.

**AM TRACKING ADJUSTMENT**

**Setting:**

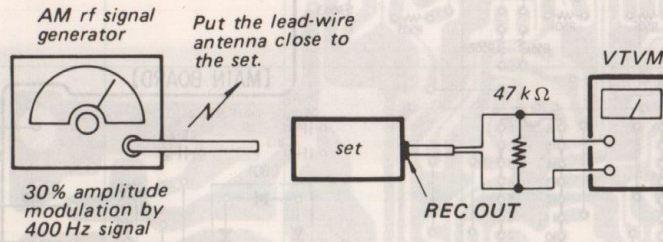

30% amplitude modulation by 400 Hz signal

**AM FREQUENCY COVERAGE ADJUSTMENT**

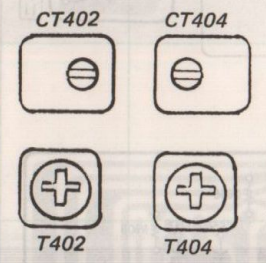
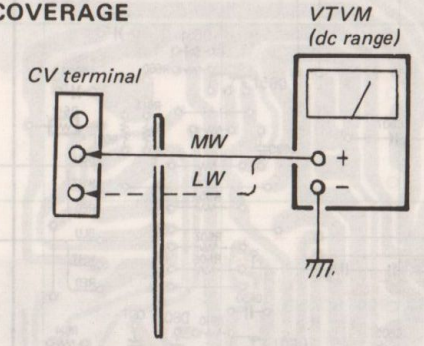

**MW**

Frequency display in set	Voltage at TP (CV)	Adjustment parts
1. 531kHz	1.1V ± 0.2V	T402
2. 1,602kHz	9.0V ± 0.2V	CT402

**LW**

Frequency display in set	Voltage at TP (CV)	Adjustment parts
1. 153kHz	1.0V ± 0.2V	T404
2. 344kHz	9.0V ± 0.2V	CT404

**Procedure:**

1. Tune the set to the SG signal.
2. Adjust for a maximum reading on VTVM.

**MW**

SG and set frequency	Adjustment parts	Reading on VTVM
1. 603kHz	T401	Maximum
2. 1404kHz	CT401	

**LW**

SG and set frequency	Adjustment parts	Reading on VTVM
1. 170kHz	T405	Maximum
2. 310kHz	CT403	

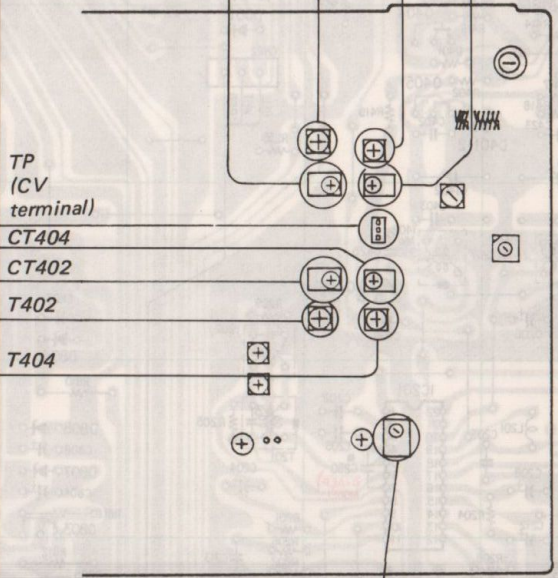

1,404kHz	T205
Adjust for a maximum reading on VTVM.	
AM IF ADJUSTMENT	

**IC BLOCK DIAGRAMS**

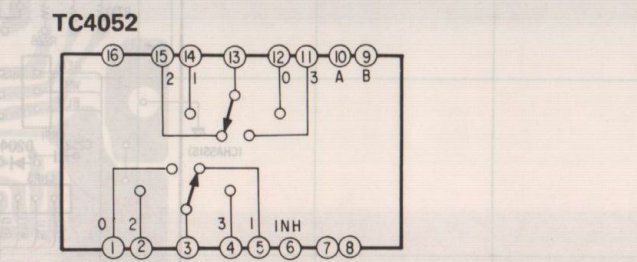
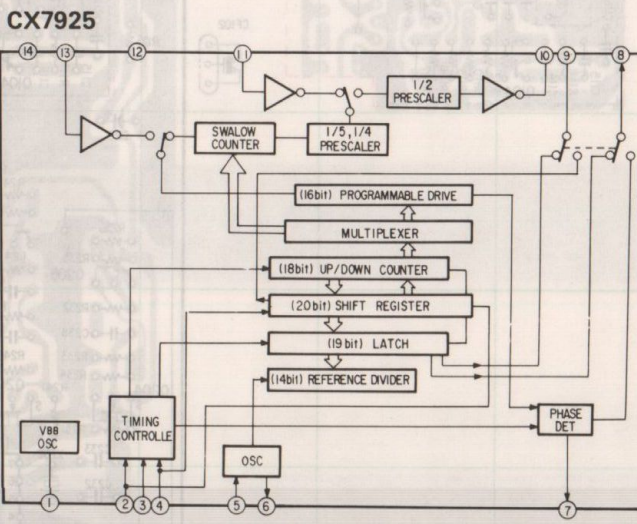
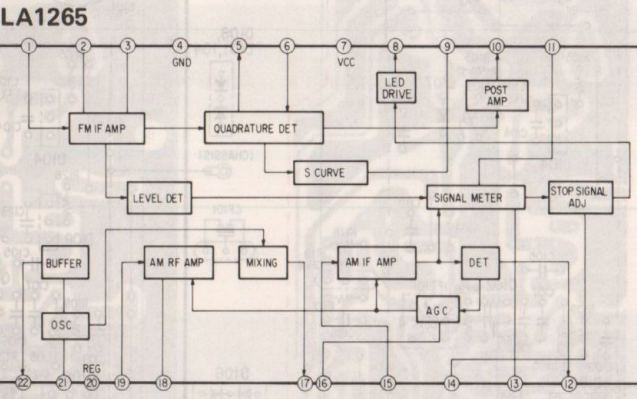
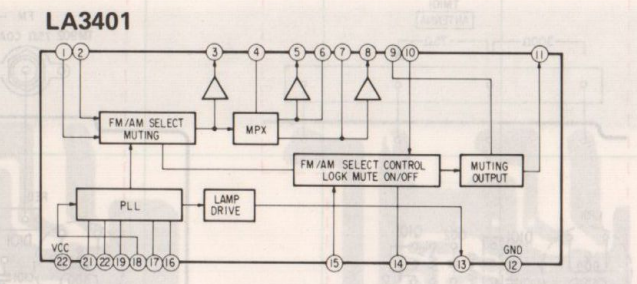

SECTION 3  
DIAGRAMS

STR-AV20L STR-AV20L

STR-AV20L STR-AV20L

3-1. MOUNTING DIAGRAM • See page 17 for Semiconductor Lead Layouts and Semiconductor Location.

- — parts extracted from the component side.
- — parts extracted from the conductor side.
- — part mounted on the conductor side.
- — indicates side identified with part number.

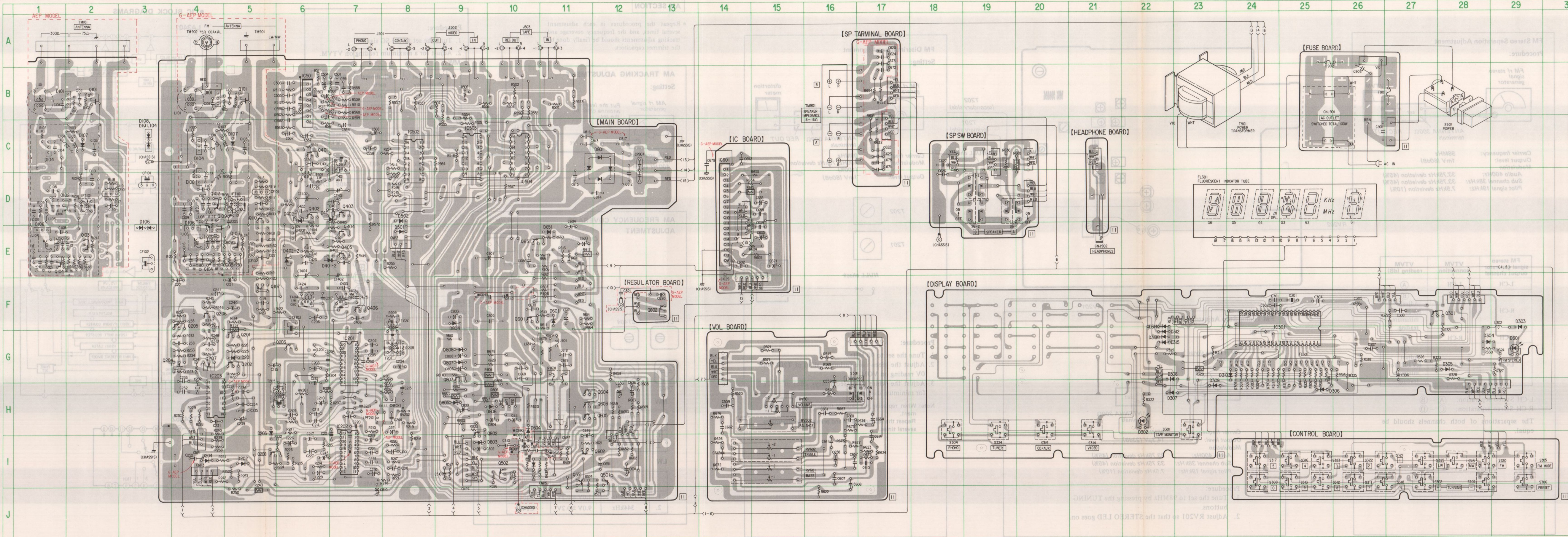

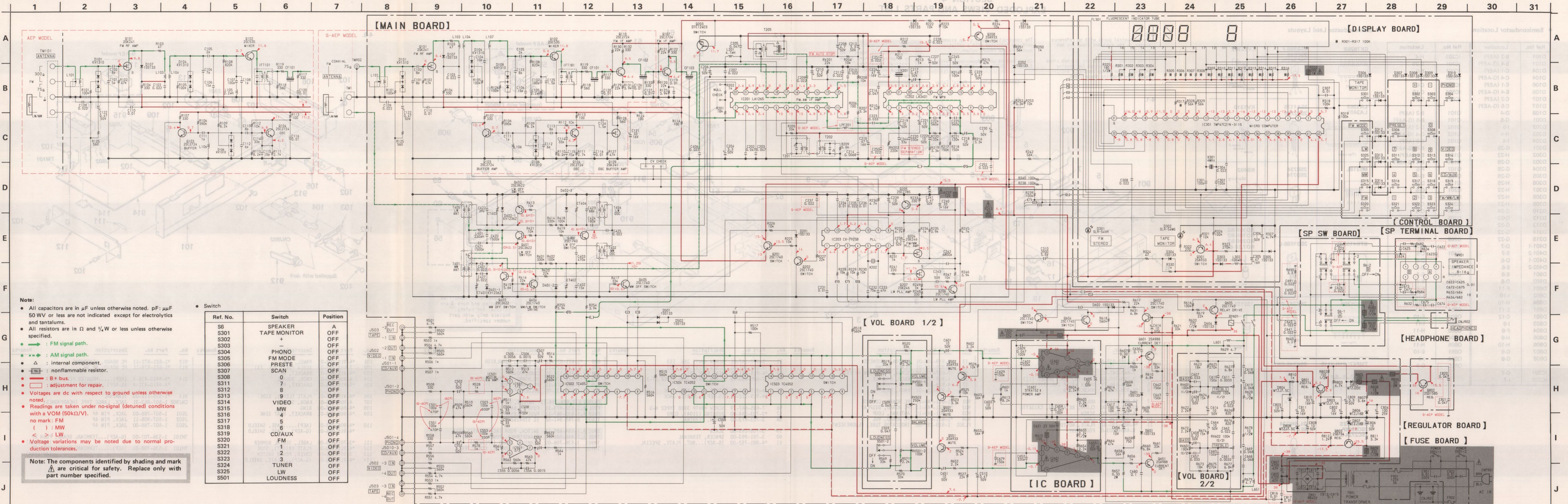

- Note:**
- All capacitors are in  $\mu\text{F}$  unless otherwise noted.  $\text{pF} = \mu\text{F} \times 10^{-6}$ . 50 WV or less are not indicated except for electrolytics and tantalums.
  - All resistors are in  $\Omega$  and  $1/4\text{W}$  or less unless otherwise specified.
  - — : FM signal path.
  - — : AM signal path.
  - $\Delta$  : internal component.
  - : nonflammable resistor.
  - — : B+ bus.
  - : adjustment for repair.
  - Voltages are dc with respect to ground unless otherwise noted.
  - Readings are taken under no-signal (detuned) conditions with a VOM (50k $\Omega$ /V).
  - no mark: FM
  - ( ) : MW
  - < > : LW
  - Voltage variations may be noted due to normal production tolerances.

• Switch

Ref. No.	Switch	Position
S6	SPEAKER	OFF
S301	TAPE MONITOR	OFF
S302	+	OFF
S303		OFF
S304	PHONO	OFF
S305	FM MODE	OFF
S306	PREST	OFF
S307	SCAN	OFF
S308	0	OFF
S311	7	OFF
S312	8	OFF
S313	9	OFF
S314	VIDEO	OFF
S315	MW	OFF
S316	4	OFF
S317	5	OFF
S318	6	OFF
S319	CD/AUX	OFF
S320	FM	OFF
S321	1	OFF
S322	2	OFF
S323	3	OFF
S324	TUNER	OFF
S325	LW	OFF
S501	LOUDNESS	OFF

**Note:** The components identified by shading and mark  $\Delta$  are critical for safety. Replace only with part number specified.

SECTION 4 EXPLODED VIEWS AND PARTS LIST

● Semiconductor Location

Table with 4 columns: Ref No., Location, Ref No., Location. Lists component locations for various ICs and diodes.

● Semiconductor Lead Layouts

Diagrams showing lead layouts for various semiconductor components like CX7925B, LA1265, M5218L, STK4152-II, TC4052BP, TMP47C21N-3115, DTC124ES, 2SA988-F, 2SA1175, 2SB734, 2SD1585-L, 2SK241-GR2, GL-5NG24, KV1236Z, KV1310, RB402, RD16E-B2, RD18E-B2, RD20E-B2, RD75E-B2, and 1SS133.

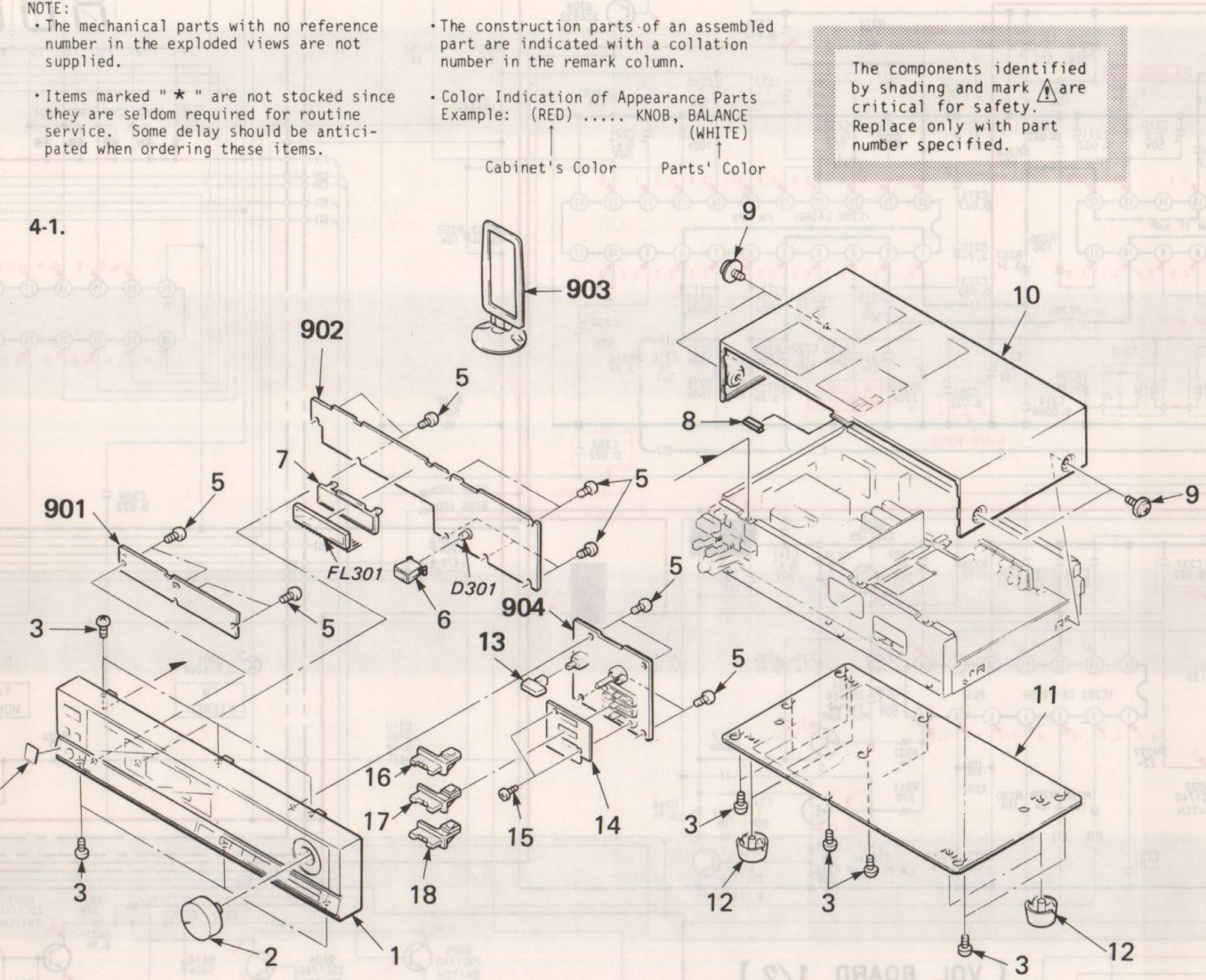

Parts list for diagram 4-1, including part numbers, descriptions, and remarks for items 1 through 18.

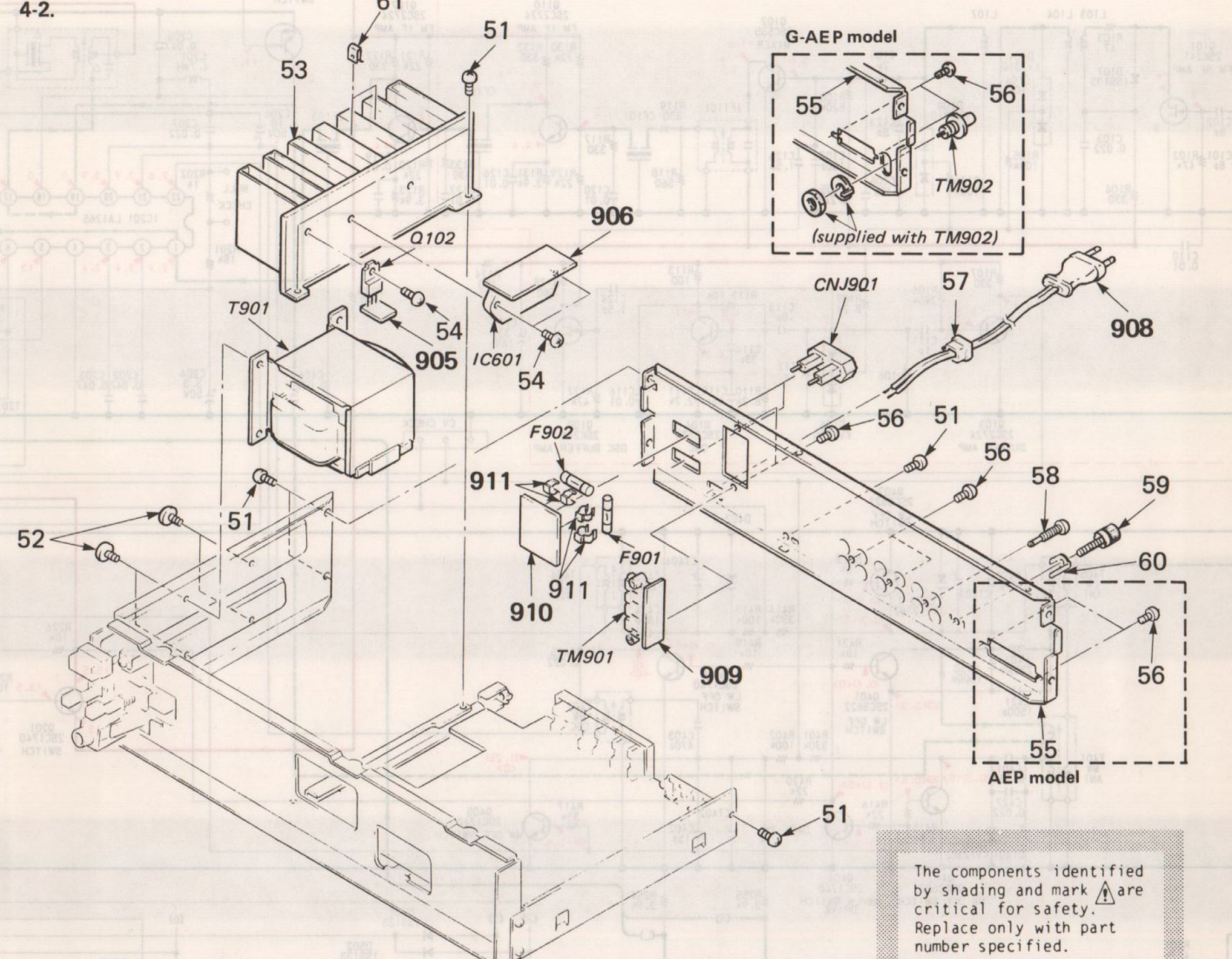

Parts list for diagram 4-2, including part numbers, descriptions, and remarks for items 1 through 61.

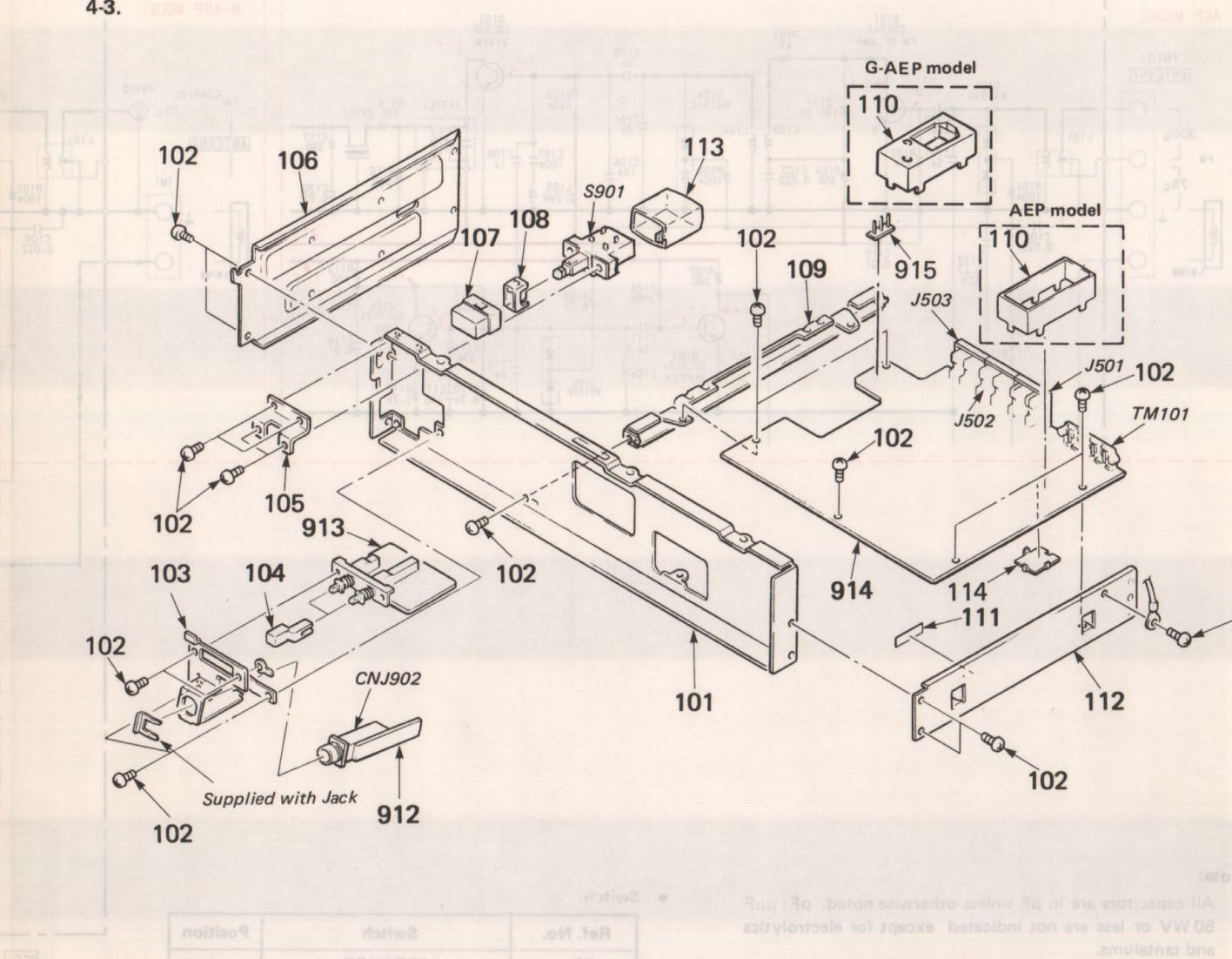

Parts list for diagram 4-3, including part numbers, descriptions, and remarks for items 1 through 114.

NOTE: The mechanical parts with no reference number in the exploded views are not supplied.

The construction parts of an assembled part are indicated with a collation number in the remark column.

The components identified by shading and mark are critical for safety. Replace only with part number specified.

## SECTION 5 ELECTRICAL PARTS LIST

## NOTE:

- Items marked " \* " are not stocked since they are seldom required for routine service. Some delay should be anticipated when ordering these items.
- If there are two or more same circuits in a set such as a stereophonic machine, only typical circuit parts may be indicated and capacitors and resistors in other same circuits may be omitted.

## CAPACITORS:

MF:μF, PF:μμF.

## RESISTORS

• All resistors are in ohms.

• F : nonflammable

## COILS

• MMH : mH, UH : μH

## SEMICONDUCTORS

In each case, U : μ, for example:

UA.... : μA..., UPA.... : μPA..., UPC.... : μPC,

UPD.... : μPD...

The components identified by shading and mark  are critical for safety. Replace only with part number specified.

## ELECTRICAL PARTS

Ref.No.	Part No.	Description			
901	*1-621-746-11	PC BOARD, CONTROL			
902	*1-621-745-11	PC BOARD, DISPLAY			
903	1-501-349-11	ANTENNA, LOOP			
904	*1-621-873-11	PC BOARD, VOL			
905	*1-621-877-11	PC BOARD, REGULATOR			
906	*1-621-875-11	PC BOARD, IC			
908	1-559-124-11	CORD, POWER			
909	*1-621-878-11	PC BOARD, SP TERMINAL			
910	*1-621-876-11	PC BOARD, FUSE			
911	1-533-131-00	HOLDER, FUSE			
912	*1-621-872-11	PC BOARD, HEADPHONE			
913	*1-621-879-11	PC BOARD, SP SW			
914	*A-4410-416-A	(AEP)....MOUNTED PCB, MAIN			
	*A-4410-431-A	(G-AEP)....MOUNTED PCB, MAIN			
915	*1-535-116-00	TERMINAL			
916	*1-560-060-00	PIN, CONNECTOR 2P			
917	*1-560-061-00	PIN, CONNECTOR 3P			
918	*1-562-249-00	SOCKET, CONNECTOR 4P			
919	*1-562-250-00	SOCKET, CONNECTOR 5P			
920	*1-562-251-00	SOCKET, CONNECTOR 6P			
921	*1-562-327-00	SOCKET, CONNECTOR 3P			
922	*1-562-564-11	SOCKET, CONNECTOR 8P			
923	*1-564-779-11	PLUG, CONNECTOR (2.5MM) 6P			
C101	1-102-807-00	(AEP)....CERAMIC 5PF	1PF	50V	
C101	1-102-945-00	(G-AEP)...CERAMIC 8PF	0.5PF	50V	
C102	1-102-945-00	CERAMIC 8PF	0.5PF	50V	
C103	1-161-055-00	CERAMIC 0.022MF	20%	25V	
C104	1-102-809-00	(AEP)....CERAMIC 7PF	1PF	50V	
C104	1-102-947-00	(G-AEP)...CERAMIC 10PF	0.5PF	50V	
C105	1-102-935-00	CERAMIC 2PF	0.25PF	50V	
C106	1-102-951-00	CERAMIC 15PF	5%	50V	
C107	1-102-106-00	CERAMIC 100PF	10%	50V	
C109	1-161-055-00	CERAMIC 0.022MF	20%	25V	
C108	1-102-934-00	(AEP)....CERAMIC 1PF	0.25PF	50V	
C110	1-161-034-00	(AEP)....CERAMIC 0.022PF	20%	25V	
C110	1-161-051-00	(G-AEP)...CERAMIC 0.01MF	20%	25V	
C111	1-102-934-00	CERAMIC 1PF	0.25PF	50V	
C112	1-102-943-00	CERAMIC 6PF	0.5PF	50V	
C113	1-102-945-00	CERAMIC 8PF	0.5PF	50V	
C114	1-102-963-00	CERAMIC 33PF	5%	50V	
C115	1-102-951-00	CERAMIC 15PF	5%	50V	
C116	1-161-051-00	CERAMIC 0.01MF	10%	50V	
C119	1-161-051-00	CERAMIC 0.01MF	10%	50V	
C120	1-161-051-00	CERAMIC 0.01MF	10%	50V	
C121	1-124-963-11	ELECT 33MF	20%	16V	

## ELECTRICAL PARTS

Ref.No.	Part No.	Description			
C122	1-124-902-00	ELECT 0.47MF	20%	50V	
C123	1-102-945-00	(G-AEP)...CERAMIC 8PF	0.5PF	50V	
C124	1-101-576-00	(G-AEP)...CERAMIC 1.5PF	0.25PF	50V	
C125	1-101-576-00	(G-AEP)...CERAMIC 1.5PF	0.25PF	50V	
C126	1-161-051-00	(G-AEP)...CERAMIC 0.01MF	10%	50V	
C127	1-161-051-00	(G-AEP)...CERAMIC 0.01MF	10%	50V	
C202	1-161-021-11	CERAMIC 0.047MF	10%	25V	
C203	1-161-021-11	CERAMIC 0.047MF	10%	25V	
C204	1-123-382-00	ELECT 3.3MF	20%	50V	
C205	1-161-021-11	CERAMIC 0.047MF	10%	25V	
C206	1-123-875-91	ELECT 10MF	20%	50V	
C207	1-161-055-00	CERAMIC 0.022MF	20%	25V	
C208	1-124-927-11	ELECT 4.7MF	20%	50V	
C209	1-161-055-00	CERAMIC 0.022MF	20%	25V	
C210	1-124-904-00	ELECT 2.2MF	20%	50V	
C211	1-161-055-00	CERAMIC 0.022MF	20%	25V	
C212	1-123-382-00	ELECT 3.3MF	20%	50V	
C213	1-161-055-00	CERAMIC 0.022MF	20%	25V	
C214	1-130-481-00	MYLAR 0.0068MF	10%	50V	
C215	1-124-477-11	ELECT 47MF	20%	16V	
C216	1-136-161-00	MYLAR 0.047MF	10%	50V	
C217	1-124-902-00	ELECT 0.47MF	20%	50V	
C218	1-123-875-91	ELECT 10MF	20%	50V	
C219	1-123-875-91	ELECT 10MF	20%	50V	
C220	1-102-112-00	CERAMIC 330PF	10%	50V	
C221	1-123-875-91	ELECT 10MF	20%	50V	
C222	1-123-875-91	ELECT 10MF	20%	50V	
C223	1-136-159-00	MYLAR 0.033MF	10%	50V	
C224	1-102-115-00	CERAMIC 560PF	10%	50V	
C225	1-102-115-00	CERAMIC 560PF	10%	50V	
C226	1-124-477-11	ELECT 47MF	20%	16V	
C227	1-124-791-11	ELECT 1MF	20%	50V	
C228	1-161-055-00	CERAMIC 0.022MF	20%	25V	
C229	1-124-902-00	ELECT 0.47MF	20%	50V	
C230	1-124-791-11	ELECT 1MF	20%	50V	
C231	1-161-051-00	CERAMIC 0.01MF	10%	50V	
C232	1-102-526-00	CERAMIC 75PF	5%	50V	
C233	1-101-880-00	CERAMIC 47PF	5%	50V	
C234	1-161-051-00	CERAMIC 0.01MF	10%	50V	
C235	1-161-055-00	CERAMIC 0.022MF	20%	25V	
C236	1-161-051-00	CERAMIC 0.01MF	10%	50V	
C237	1-161-055-00	(G-AEP)...CERAMIC 0.022MF	20%	25V	
C238	1-124-184-00	ELECT 3.3MF	20%	50V	
C239	1-123-875-91	ELECT 10MF	20%	50V	
C240	1-124-963-11	ELECT 33MF	20%	16V	



ELECTRICAL PARTS

Table with columns: Ref.No., Part No., Description, Value/Type, and Voltage. Includes parts like C241 (ELECT 0.47MF 20% 25V), C242 (CERAMIC 0.022MF 20% 25V), C243 (ELECT 1MF 20% 50V), etc.

The components identified by shading and mark Δ are critical for safety. Replace only with part number specified.

ELECTRICAL PARTS

Table with columns: Ref.No., Part No., Description, Value/Type, and Voltage. Includes parts like C607 (MYLAR 0.033MF 10% 50V), C608 (ELECT 0.22MF 20% 50V), C609 (MYLAR 0.047MF 10% 100V), etc.

ELECTRICAL PARTS

Table with columns: Ref.No., Part No., Description, Value/Type, and Voltage. Includes parts like C812 (FILM 0.1MF 5% 100V), C813 (FILM 0.1MF 5% 100V), C814 (FILM 0.1MF 5% 100V), etc.

The components identified by shading and mark Δ are critical for safety. Replace only with part number specified.

ELECTRICAL PARTS

Table with columns: Ref.No., Part No., Description, Value/Type, and Voltage. Includes parts like D803 (DIODE RD7.5E-B2), D804 (DIODE RD7.5E-B2), D805 (DIODE RD20E-B2), etc.

ELECTRICAL PARTS

Table with columns: Ref.No., Part No., Description, and values for various electrical components like transistors and resistors.

ELECTRICAL PARTS

Table with columns: Ref.No., Part No., Description, and values for various electrical components like resistors and carbon parts.

ELECTRICAL PARTS

Table with columns: Ref.No., Part No., Description, and values for various electrical components like resistors and carbon parts.

ELECTRICAL PARTS

Table with columns: Ref.No., Part No., Description, and values for various electrical components like resistors, carbon parts, and metal plates.

The components identified by shading and mark ▲ are critical for safety. Replace only with part number specified.

The components identified by shading and mark ▲ are critical for safety. Replace only with part number specified.

ELECTRICAL PARTS

Ref.No.	Part No.	Description	QTY	UNIT	REF. NO.
R661	1-249-435-11	CARBON	33K	5%	1/6W
R664	1-249-437-11	CARBON	47K	5%	1/6W
R672	1-249-421-11	CARBON	2.2K	5%	1/6W
R673	1-249-432-11	CARBON	18K	5%	1/6W
R674	1-249-431-11	CARBON	15K	5%	1/6W
R675	1-247-889-00	CARBON	270K	5%	1/6W
R676	1-249-416-11	CARBON	820	5%	1/6W
R677	1-249-427-11	CARBON	6.8K	5%	1/6W
R678	1-247-727-11	CARBON	10	5%	1/2W
R679	1-249-455-11	CARBON	4.7	5%	1/4W
R680	1-215-914-11	WIREWOUND	330	10%	2W F
R682	1-247-688-11	(G-AEP)...CARBON	10	5%	1/4W
R684	1-247-688-11	(G-AEP)...CARBON	10	5%	1/4W
R690	1-247-771-00	(G-AEP)...CARBON	3.3	5%	1/6W
R802	1-247-741-11	CARBON	150	5%	1/2W
R803	1-247-721-11	CARBON	4.7K	5%	1/4W
R805	1-247-700-11	CARBON	100	5%	1/4W F
R806	1-206-477-00	METAL OXIDE	39	5%	2W F
R807	1-247-722-11	CARBON	5.6K	5%	1/4W
R808	1-247-730-11	CARBON	18	5%	1/2W F
R809	1-247-743-11	CARBON	220	5%	1/2W F
R810	1-247-713-11	CARBON	1K	5%	1/4W
R811	1-247-719-11	CARBON	3.3K	5%	1/4W
R812	1-247-714-11	CARBON	1.2K	5%	1/4W
RV201	1-228-995-00	RES, ADJ, METAL GLAZE	22K		
RV202	1-228-998-00	RES, ADJ, METAL GLAZE	220K		
RV501	1-237-629-11	RES, VAR, CARBON	100K/100K		(VOLUME)
RV502	1-230-586-11	RES, VAR, SLIDE	250K		(BALANCE)
RV601	1-230-585-11	RES, VAR, SLIDE	100K/100K		(BASS)
RV602	1-230-585-11	RES, VAR, SLIDE	100K/100K		(TREBLE)
RY601	1-515-533-11	RELAY			
S6	1-570-270-11	SWITCH, PUSH (2 KEY)			(SPEAKER)
S301	1-554-303-21	SWITCH, KEY BOARD			(TAPE MONITOR)
S302	1-554-303-21	SWITCH, KEY BOARD			(TUNING +)
S303	1-554-303-21	SWITCH, KEY BOARD			(TUNING -)
S304	1-554-303-21	SWITCH, KEY BOARD			(PHONO)
S305	1-554-303-21	SWITCH, KEY BOARD			(FM MODE)
S306	1-554-303-21	SWITCH, KEY BOARD			(PRESET)
S308	1-554-303-21	SWITCH, KEY BOARD			(0)
S311	1-554-303-21	SWITCH, KEY BOARD			(7)
S312	1-554-303-21	SWITCH, KEY BOARD			(8)
S313	1-554-303-21	SWITCH, KEY BOARD			(9)
S314	1-554-303-21	SWITCH, KEY BOARD			(VIDEO)
S315	1-554-303-21	SWITCH, KEY BOARD			(MW)
S316	1-554-303-21	SWITCH, KEY BOARD			(4)

ELECTRICAL PARTS

Ref.No.	Part No.	Description	QTY	UNIT	REF. NO.
S317	1-554-303-21	SWITCH, KEY BOARD			(5)
S318	1-554-303-21	SWITCH, KEY BOARD			(6)
S319	1-554-303-21	SWITCH, KEY BOARD			(CD/AUX)
S320	1-554-303-21	SWITCH, KEY BOARD			(FM)
S321	1-554-303-21	SWITCH, KEY BOARD			(1)
S322	1-554-303-21	SWITCH, KEY BOARD			(2)
S323	1-554-303-21	SWITCH, KEY BOARD			(3)
S324	1-554-303-21	SWITCH, KEY BOARD			(FM/MW/LW)
S325	1-554-303-21	SWITCH, KEY BOARD			(LW)
S501	1-570-584-11	SWITCH, PUSH (1 KEY)			(LOUDNESS)
S901	1-554-685-11	SWITCH, PUSH (AC POWER)			(1 KEY)
T201	1-404-650-11	COIL, DISCRIMINATOR			
T202	1-404-651-11	COIL, DISCRIMINATOR			
T205	1-404-713-11	TRANSFORMER, IF			
T401	1-402-197-11	COIL (ANTENNA)			
T402	1-406-089-11	COIL (OSC)			
T404	1-406-090-11	COIL (OSC)			
T405	1-402-071-11	COIL (ANT)			
T901	1-448-849-11	TRANSFORMER, POWER			
TM101	1-536-707-00	(G-AEP)...TERMINAL BOARD, PUSH 2P			(ANTENNA)
TM101	1-536-708-00	(AEP)...TERMINAL BOARD, PUSH 4P			(ANTENNA)
TM901	1-536-706-00	TERMINAL BOARD (SPEAKER)			
TM902	1-561-919-00	(G-AEP)...SOCKET, CONNECTOR			
X201	1-567-250-11	OSCILLATOR, CERAMIC			
X202	1-567-125-00	VIBRATOR, CRYSTAL			
X301	1-527-822-00	OSCILLATOR, CERAMIC			

ACCESSORY & PACKING MATERIAL

Part No.	Description
1-501-291-21	(AEP)...ANTENNA, FEEDER
3-701-630-00	BAG, POLYETHYLENE
3-765-953-11	(G-AEP)...MANUAL, INSTRUCTION
3-765-953-41	(AEP)...MANUAL, INSTRUCTION
4-858-078-00	SHEET, PROTECTION
4-906-822-01	FRAME, REINFORCEMENT
4-919-137-71	INDIVIDUAL CARTON
4-919-138-01	CUSHION, LOWER
4-919-139-01	CUSHION, UPPER

TROUBLESHOOTING

PROBLEM	SOLUTION
STEREO indicator flickers or does not light up when FM stereo programs are received.	<ul style="list-style-type: none"> <li>Adjust the antenna or check an external FM antenna connection.</li> <li>Press FM MODE to disengage the stereo mode.</li> </ul>
The figures in the display window do not stop at the desired station during sweep tuning.	<ul style="list-style-type: none"> <li>Adjust the antenna.</li> <li>Tune in the station using the direct access tuning.</li> </ul>
Stations cannot be tuned in correctly when the number button is pressed.	<ul style="list-style-type: none"> <li>Memorize the frequency correctly.</li> </ul>
MW/LW stations cannot be tuned in.	<ul style="list-style-type: none"> <li>Connect the supplied LW/MW layout-free antenna to the LW/MW external ANTENNA terminals.</li> </ul>
Audio is not heard.	<ul style="list-style-type: none"> <li>Check the speaker and program source connections.</li> <li>Check that the appropriate Function or TAPE MONITOR button is pressed.</li> <li>Check the SPEAKERS selectors.</li> </ul>
One channel does not transmit audio, or the volume from the left and right speakers is unbalanced.	<ul style="list-style-type: none"> <li>Adjust the BALANCE control.</li> <li>Check the speaker connections.</li> </ul>
There is an abrupt loss of sound from one or both of the speakers.	<ul style="list-style-type: none"> <li>Turn off the receiver, and check the speaker terminals or speaker cord for a short. (This symptom may occur when the protection circuit inside the unit activates.)</li> </ul>
Sound transmitted from the speaker is reversed.	<ul style="list-style-type: none"> <li>Connect the speaker correctly.</li> </ul>
Severe hum or noise is heard.	<ul style="list-style-type: none"> <li>Use shielded connecting cords.</li> <li>Separate the audio components and the TV.</li> <li>Connect the ground wire to the ANTENNA ground terminal.</li> <li>Clean any dirty plugs and jacks with a cloth lightly moistened with alcohol.</li> </ul>

The components identified by shading and mark  $\Delta$  are critical for safety. Replace only with part number specified.

The components identified by shading and mark  $\Delta$  are critical for safety. Replace only with part number specified.

TROUBLESHOOTING

PROBLEM	SOLUTION
SEVERE HUM OR NOISE IS HEARD.	<ul style="list-style-type: none"> <li>• Clean any dirty plugs and jacks with a cloth lightly moistened with alcohol.</li> <li>• Separate the audio components and the TV.</li> <li>• Connect the ground wire to the ANTENNA ground terminal.</li> <li>• Use shielded connecting cords.</li> <li>• Connect the speaker correctly.</li> </ul>
SOUND TRANSMITTED FROM THE SPEAKER IS REVERSED.	<ul style="list-style-type: none"> <li>• Turn off the receiver, and check the speaker terminals or speaker cord for a short.</li> <li>• (This symptom may occur when the protection circuit inside the unit activates.)</li> </ul>
THERE IS AN ABRUPT LOSS OF SOUND FROM ONE OR BOTH OF THE SPEAKERS.	<ul style="list-style-type: none"> <li>• Check the speaker connections.</li> <li>• Adjust the BALANCE control.</li> </ul>
ONE CHANNEL DOES NOT TRANSMIT AUDIO, OR THE VOLUME FROM THE LEFT AND RIGHT SPEAKERS IS UNBALANCED.	<ul style="list-style-type: none"> <li>• Check the SPEAKERS selector.</li> <li>• Check that the appropriate FUNCTION or TAPE MONITOR button is pressed.</li> <li>• Check the speaker and program source connections.</li> </ul>
MW/LW STATIONS CANNOT BE TUNED IN.	<ul style="list-style-type: none"> <li>• Connect the supplied LW/MW layout-free antenna to the LW/MW external ANTENNA terminals.</li> </ul>
STATIONS CANNOT BE TUNED IN CORRECTLY WHEN THE NUMBER BUTTON IS PRESSED.	<ul style="list-style-type: none"> <li>• Memorize the frequency correctly.</li> </ul>
THE FIGURES IN THE DISPLAY WINDOW DO NOT STOP AT THE DESIRED STATION DURING SWEEP TUNING.	<ul style="list-style-type: none"> <li>• Tune in the station using the direct access tuning.</li> <li>• Adjust the antenna.</li> </ul>
STEREO INDICATOR FLICKERS OR DOES NOT LIGHT UP WHEN FM STEREO PROGRAMS ARE RECEIVED.	<ul style="list-style-type: none"> <li>• Press FM MODE to disengage the stereo mode.</li> <li>• Adjust the antenna or check an external FM antenna connection.</li> </ul>