

# STR-AV220/AV220A/AV320R/AV320RA

## SERVICE MANUAL

*AEP Model*  
STR-AV220A/320RA

*UK Model*  
STR-AV320R

*West Germany Model*

STR-AV220/320R



Photo : STR-AV320

### SPECIFICATIONS

#### Amplifier section

Continuous RMS power output

STR-AV220/AV220A :

25 W + 25 W (4/8 ohms, at 40 Hz - 20 kHz  
less than 0.8% total harmonic distortion)

STR-AV320R(WG)/AV320RA :

40 W + 40 W (4/8 ohms, at 40 Hz - 20 kHz  
less than 0.8% total harmonic distortion)

STR-AV320R(UK) : 50W+50W (4/8 ohms, at 40Hz-20kHz  
less than 0.8% total harmonic distortion)

Power output

IEC/DIN : STR-AV220/AV220A

30 W + 30 W (4 ohms at 1 kHz 0.7%)

STR-AV320R (WG) /AV320RA

50 W + 50 W (4 ohms at 1 kHz 0.7%)

STR-AV320R (UK)

55W+55W (8 ohms at 1kHz 0.7%)

Harmonic distortion

Less than 0.8% at rated output

Frequency response

PHONO: RIAA equalization curve  $\pm 0.5$  dB

CD

VIDEO | 40 Hz - 50 kHz  $\pm 0.5$  dB

TAPE

Inputs

	Sensitivity	Impedance	S/N (weighting network, input level)
PHONO	2.5 mV	50 kilohms	74 dB 72 dB* (A, 2.5 mV)
CD VIDEO TAPE	150 mV	50 kilohms	95 dB 80 dB* (A, 150 mV)

\* '78 IHF

#### Outputs

REC OUT, VIDEO (AUDIO) OUT	Voltage 150 mV Impedance 10 kilohms
SPEAKER A, B	Accepts speakers of 4 - 16 ohms
HEADPHONES	Accepts low and high impedance headphones

Tone controls

BASS:  $\pm 10$  dB at 100 Hz

TREBLE:  $\pm 10$  dB at 10 kHz

Muting

-20 dB (STR-AV320RA only)

DBFB

+12 dB at 70 Hz

#### Tuner section

	FM tuner section	AM tuner section
Tuning range	87.5 - 108 MHz	531 - 1,602 kHz
Antenna terminals	75 ohms, unbalanced	External antenna terminal
Sensitivity at 50 dB quieting	18.3 dBf, 4.5 $\mu$ V (mono) 38.3 dBf, 45 $\mu$ V (stereo)	—
Usable sensitivity	11.2 dBf, 2 $\mu$ V (IHF)	Loop antenna: 500 $\mu$ V (at 1,000 kHz)

- Continued on page 2 -



FM STEREO FM-AM RECEIVER  
**SONY**®

	FM tuner section	AM tuner section
Signal-to-noise ratio	76 dB (mono) 70 dB (stereo)	54 dB (at 50 mV/m)
Harmonic distortion	0.3% (mono), 0.5% (stereo) at 1 kHz	0.5% (at 50 mV/m, 400 Hz)
Selectivity	60 dB at 400 kHz	30 dB at 9 kHz
Separation	45 dB at 1 kHz	—
Frequency response	30 Hz - 15 kHz $\pm 3$ dB	—

**General System**

Tuner section: PLL quartz-locked digital synthesizer system  
 Pre-amplifier section: low-noise NF type equalizer amp  
 Power amplifier section: quasi-complementary SEPP

**Power requirements**

220V AC, 50/60Hz : AEP, West Germany Model  
 240V AC, 50/60Hz : UK Model

**Power consumption**

STR-AV220 / AV220A : 85W  
 STR-AV320R (WG) / AV320RA : 120W  
 STR-AV320R (UK) : 230W  
 In standby condition: 5 watts (STR-AV320RA / AV320R)

**AC outlets**

One switched (100 watts) (STR-AV320RA / AV320R)

**Dimensions**

Approx. 430 × 110 × 300 mm (w/h/d)  
 (17 × 4 3/16 × 11 7/8 inches)  
 including projecting parts and controls

**Weight**

Approx. 5.8 kg (12 lb 13 oz) net (STR-AV220 / AV220A)  
 Approx. 6.5 kg (14 lb 5 oz) net (STR-AV320R / AV320RA)

**Accessories supplied**

FM wire antenna (1)  
 AM loop antenna (1)  
 Remote Commander RM-S103 (1)  
 Remote Commander RM-U203 (1) (STR-AV320R:UK)  
 Sony batteries SUM 3(NS) (2)

Design and specifications subject to change without notice.

**TABLE OF CONTENTS**

<u>Section</u>	<u>Title</u>	<u>Page</u>
<b>1. GENERAL</b>		
1-1.	Location and Function of Controls.....	3
<b>2. ELECTRICAL ADJUSTMENTS</b> .....		4
<b>3. DIAGRAMS</b>		
3-1.	Block Diagram .....	5
3-2.	Semiconductor Lead Layouts.....	8
3-3.	Printed Wiring Boards -Main Section- .....	9
3-4.	Schematic Diagram -Main Section- .....	13
3-5.	Printed Wiring Boards -Tuner Section- .....	17
3-6.	Schematic Diagram -Tuner Section-.....	19
3-7.	IC Block Diagrams .....	18
3-8.	Explanation of IC301 ( $\mu$ PD75206).....	21
<b>4. EXPLODED VIEWS</b> .....		23
<b>5. ELECTRICAL PARTS LIST</b> .....		26

**CAUTION**

Danger of explosion if battery is incorrectly replaced. Replace only with the same or equivalent type recommended by the equipment manufacturer. Discard used batteries according to manufacturer's instructions.

**ADVARSELI**

Lithiumbatteri-Eksplosjonsfare ved feilagtig handling.  
 Udskiftning ma kun ske med batteri af samme fabrikat og type.  
 Lever det brugte batteri tiibage til leverand  $\phi$  ren.

**ADVARSEL**

Lithiumbatteri-Eksplosjonsfare.  
 Ved utskifting benyttes kun batteri som anbefalt av apparatfabrikanten.  
 Brukt batteri returneres apparatleverand  $\phi$  ren.

**VARNING**

Explosionsfara vid felaktigh batteribyte.  
 Anvand samma batterityp eller en ekvivalent typ som rekommenderas av apparattillverkaren.  
 Kassera anvant batteri enligt fabrikantens instruktion.

**VAROITUS**

Paristo voi rajahtaa, jos se on virheellisesti asennettu.  
 Vaihda paristo aincastaan laitevalmistajan suosittelemaan tyyppiin. Havita kaytetty paristo valmistajan ohjeiden mukaisesti.

**SAFETY-RELATED COMPONENT WARNING!!**

COMPONENTS IDENTIFIED BY MARK  $\Delta$  OR DOTTED LINE WITH MARK  $\Delta$  ON THE SCHEMATIC DIAGRAMS AND IN THE PARTS LIST ARE CRITICAL TO SAFE OPERATION. REPLACE THESE COMPONENTS WITH SONY PARTS WHOSE PART NUMBERS APPEAR AS SHOWN IN THIS MANUAL OR IN SUPPLEMENTS PUBLISHED BY SONY.

## SECTION 1 GENERAL

### 1-1. LOCATION AND FUNCTION OF CONTROLS

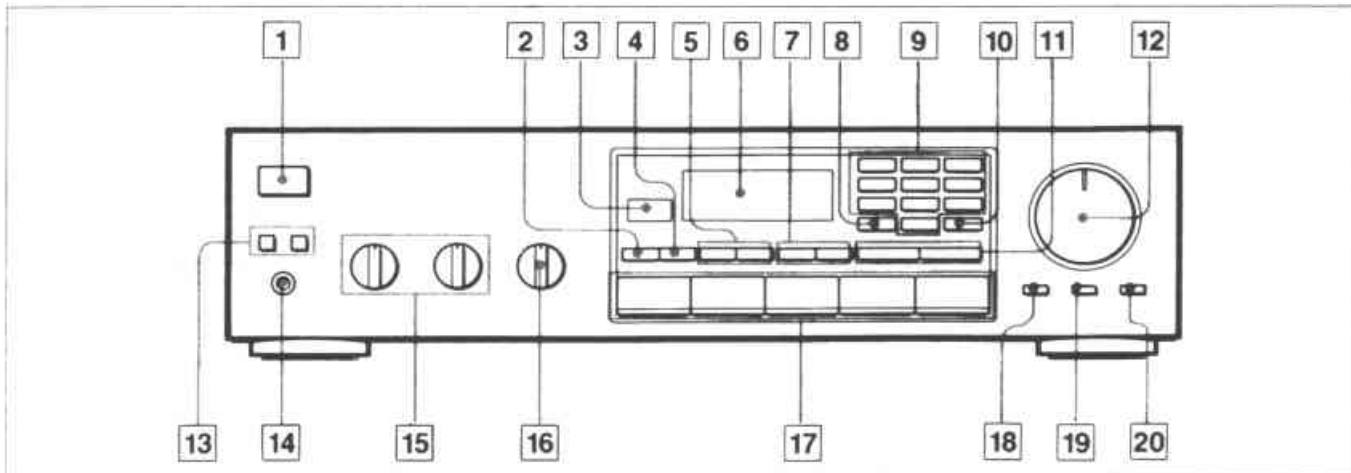

- [1] POWER switch**
- [2] DIRECT TUNING button**
- [3] Remote sensor (STR-AV320RA only)**
- [4] FM MODE button**  
When an FM stereo program is noisy or hard to receive, press this button. The STEREO indicator goes out (the sound is heard in monaural, but the reception will be improved). To return to the stereo mode, press again or change the frequency.
- [5] BAND selectors**
- [6] Display window**
- [7] TUNING +/- buttons**
- [8] MEMORY button**
- [9] Numeric buttons**
- [10] SHIFT button**
- [11] PRESET +/- buttons**
- [12] VOLUME control and indicator**  
The indicator is only equipped with the STR-AV320RA.
- [13] SPEAKERS selectors**  
Depress to select which speaker system to drive. For both speaker systems, depress A and B.
- [14] HEADPHONES jack (stereo phone jack)**
- [15] TONE controls**  
Turn the TREBLE control to adjust the high frequency sound. Turn BASS control to adjust the low frequency sound.
- [16] BALANCE control**  
Turn clockwise to decrease the left channel volume, and turn counterclockwise to decrease the right channel volume.
- [17] Function selectors**
- [18] DBFB (Dynamic Bass Feed Back) button and indicator**  
To reinforce the bass frequency sound, press this button.
- [19] MUTING button and indicator (STR-AV320RA only)**  
Press to attenuate the sound level immediately (-20 dB attenuation). Pressing this button makes the indicator be lighted. To restore the sound level, press again.
- [20] SURROUND button and indicator**  
To obtain the surround effect, press this button.

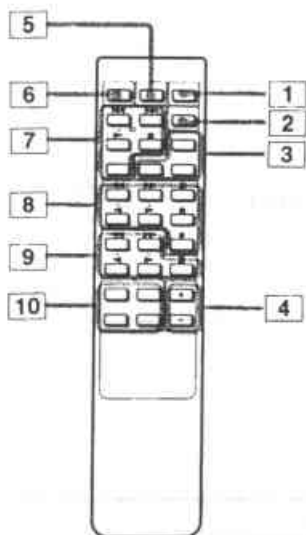

- [1] POWER button**
- [2] DBFB button**
- [3] TUNER PRESET +/- and SHIFT buttons**
- [4] VOLUME +/- buttons**
- [5] SURROUND button**
- [6] MUTING button**

- [7] CD player operation buttons**  
D. (disc) SKIP: When your CD player is equipped with a multi-disc changer, use this button to select loaded disc.  
CD ▶: Selects the CD function and starts CD-playback.
- [8] DECK B operation buttons (also for single tape deck)**  
DECK B ◀/▶: Select tape function and start tape playback on deck B.
- [9] DECK A operation buttons**  
DECK A ◀/▶: Select tape function and start tape playback on deck A.
- [10] Function select buttons**

#### Notes on the remote commander

For the functions other than the receiver's own ones, the remote commander is effective only with Sony components having a remote sensor with  mark.

## SECTION 2 ELECTRICAL ADJUSTMENTS

### FM SECTION

#### • FM Discriminator (NULL) Adjustment

Setting :

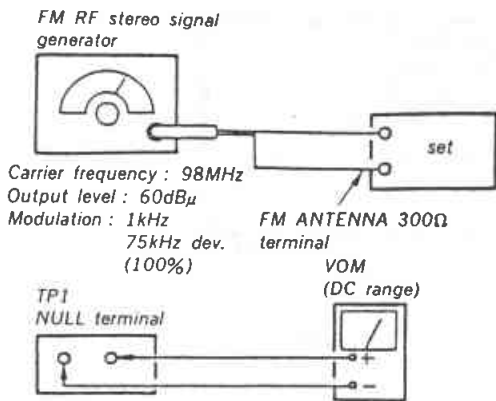

#### Procedure :

1. Tune the set to 98MHz.
2. Adjust T21 for 0V reading on the VOM.

Note : FM Tuning Level adjustment should be made after FM discriminator adjustment.

#### • FM Stereo Operation Level Adjustment

Setting :

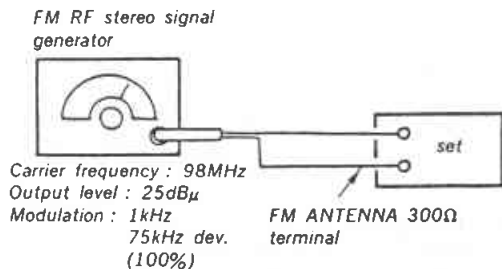

#### Procedure :

1. Tune the set to 98MHz.
2. Adjust RV24 so that the STEREO LED goes on.

#### Note on Ceramic Filter (CF1, 2) Replacement.

This set employs two ceramic filters (CF1, 2) which should have the same color marking to identify their center frequency. Therefore FM IF offset adjustment by (\* A, \* B) connection is necessary to match the center frequency of the ceramic filters used with FM intermediate frequency.

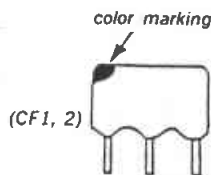

#### • FM Stereo Separation Adjustment

Setting :

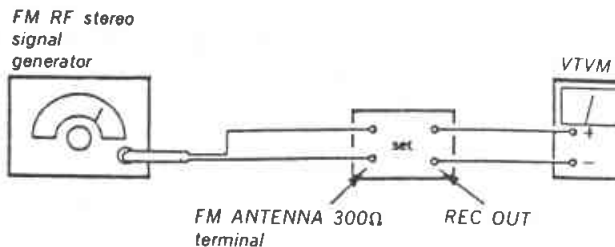

#### Procedure :

Tune the set to 98MHz.

FM stereo signal generator output channel	VTVM connection	VTVM reading (dB)
L-CH	L-CH	Ⓐ
R-CH	L-CH	Ⓑ Adjust RV21 for minimum reading.
R-CH	R-CH	Ⓒ
L-CH	R-CH	Ⓓ Adjust RV21 for minimum reading.

L-CH Stereo separation : Ⓐ - Ⓑ

R-CH Stereo separation : Ⓒ - Ⓓ

The separations of both channels should be equal.

○ : short

× : open

Ceramic filter		Connection		FM intermediate frequency (MHz)
Color mark	Center frequency (MHz)	* A (D326)	* B (D327)	
White	10.750	×	○	10.750
Red	10.700	×	×	10.700
Black	10.650	○	○	10.650

**AM SECTION**

• AM Meter Adjustment

Setting :

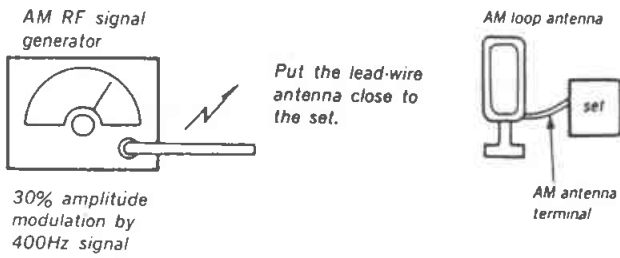

**Procedure :**

1. Tune the set to 1,050kHz.
2. Adjust the RV23 so that the 5 point segment of the signal meter goen on.

Adjustment Location : tuner board

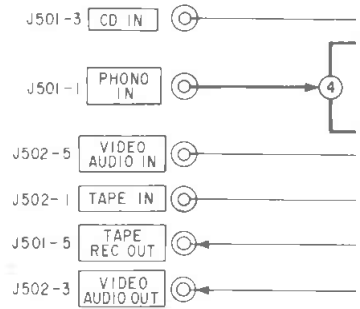
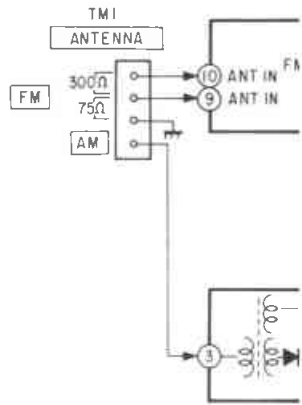
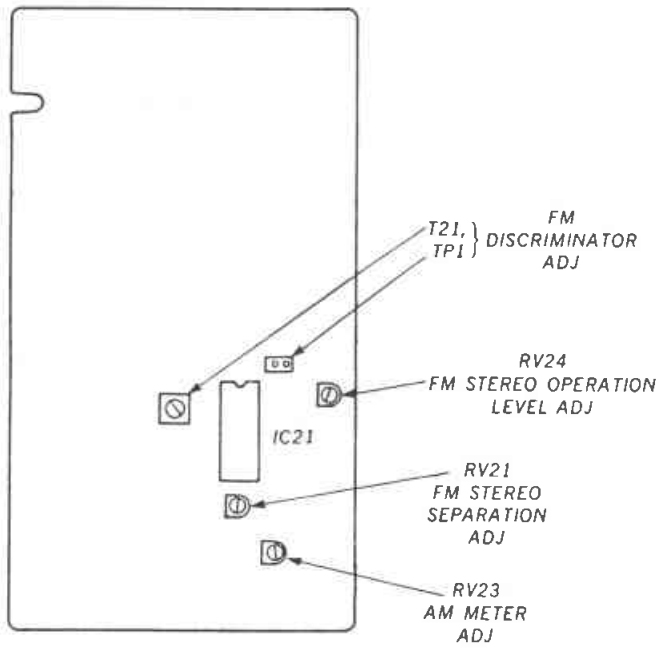

— R-CH IS OM

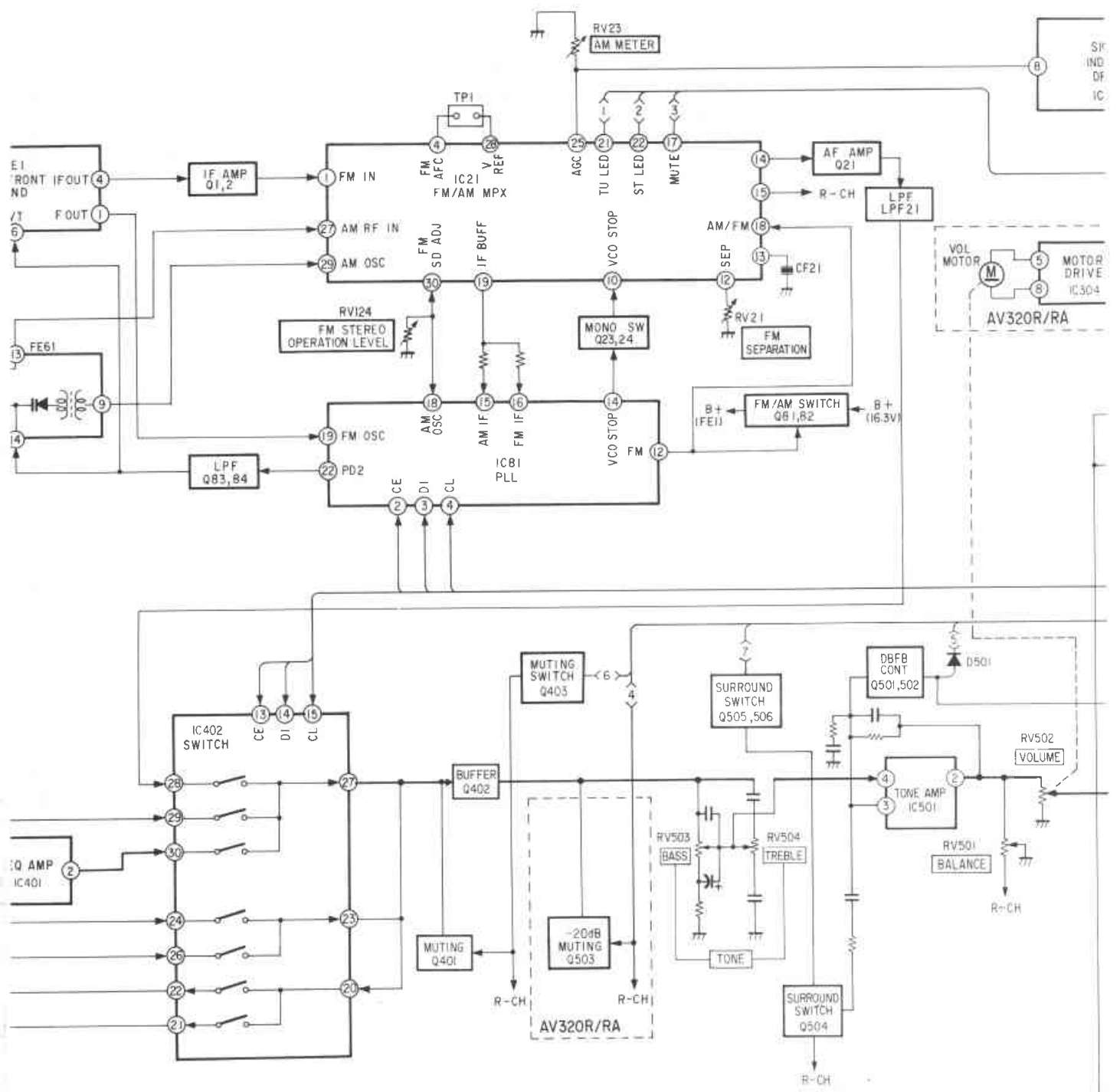

MISSION —

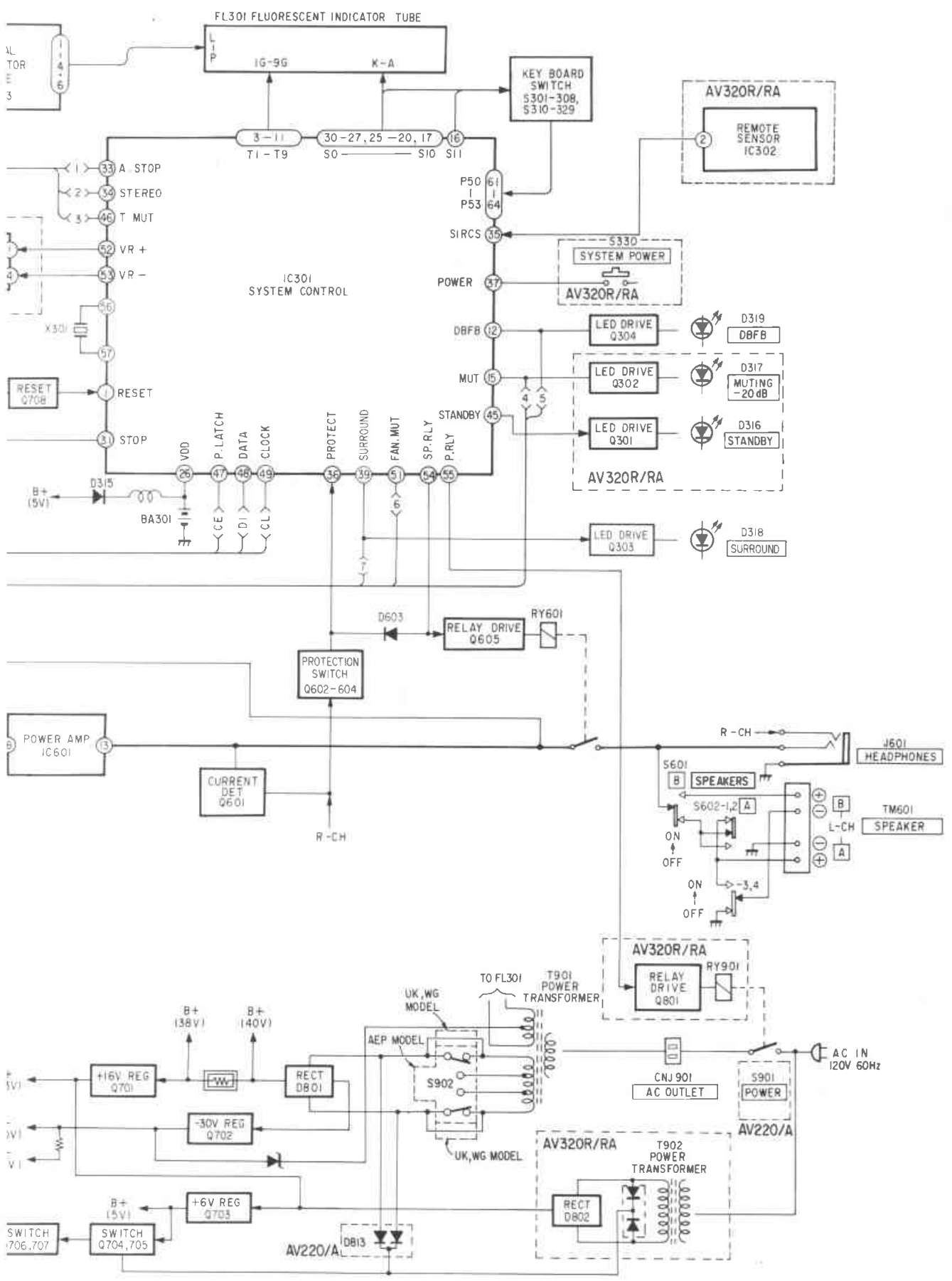

### CIRCUIT BOARDS LOCATION

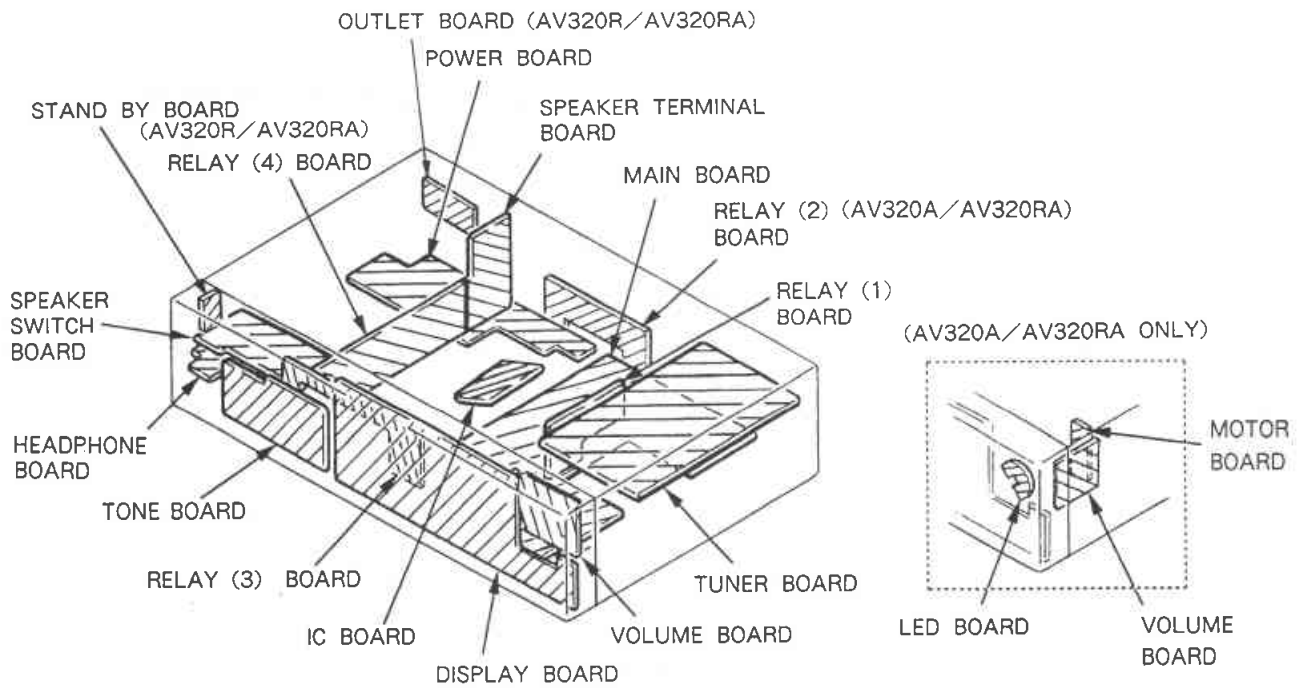

### 3.2. SEMICONDUCTOR LEAD LAYOUTS

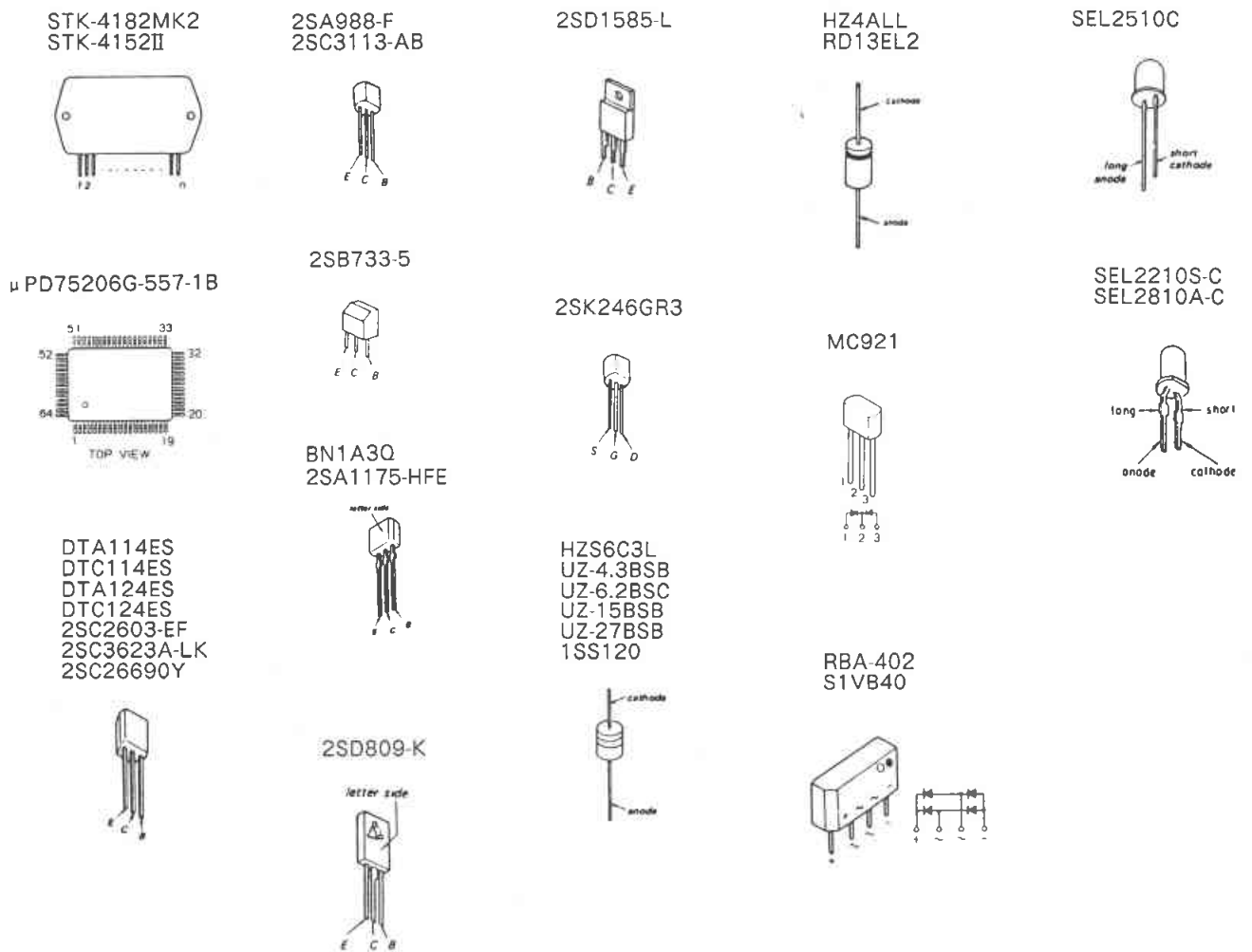



• SEMICONDUCTOR LOCATION

Ref. No.	Location	Ref. No.	Location
IC301	C-3	D312	B-2
IC302	C-1	D313	D-2
IC303	D-4	D314	C-4
IC304	B-10	D315	C-4
IC401	C-13	D316	D-1
IC402	D-15	D317	B-10
IC501	C-30	D318	B-10
IC601	F-19	D319	B-9
		D320	D-3
		D322	D-8
Q301	D-1		
Q302	C-8		
Q303	C-8	D323	D-8
Q304	C-8	D324	D-8
Q401	D-16	D326	C-8
		D327	D-8
		D328	I-4
Q402	F-15		
Q403	I-15		
Q451	D-16	D401	I-15
Q452	F-15	D402	I-15
Q501	C-28	D501	C-28
		D502	C-28
		D601	F-17
Q502	C-29		
Q503	C-27		
Q504	C-28	D602	I-16
Q505	C-27	D603	I-17
Q506	C-28	D604	J-16
		D605	J-15
		D607	I-17
Q551	C-28		
Q552	C-29		
Q553	C-27	D651	F-17
Q601	F-17	D702	I-16
Q602	E-17	D703	J-17
		D704	H-16
		D705	H-16
Q603	E-18		
Q604	E-18		
Q605	I-17	D706	B-17
Q651	F-18	D707	B-17
Q701	I-16	D708	C-17
		D709	J-15
		D710	I-14
Q702	H-16		
Q703	C-17		
Q704	C-17	D711	I-14
Q705	C-17	D801	D-17
Q706	D-17	D802	J-21
		D803	H-21
Q707	D-17		
Q708	J-14	AV220/AV220A	
Q709	I-14	D813 B-18	
Q801	I-21	AV320R/AV320RA	
D301	C-6	D813 J-21	
D302	C-6		
D303	C-6		
D304	C-6		
D305	C-5		
D306	C-5		
D307	C-5		
D308	C-5		
D309	C-5		
D311	C-4		

Note :

- : parts extracted from the component side.
- : parts mounted on the conductor side.
- \*A, \*B : See Page 4 for Note on Ceramic Filter (CF1, 2) Replacement.

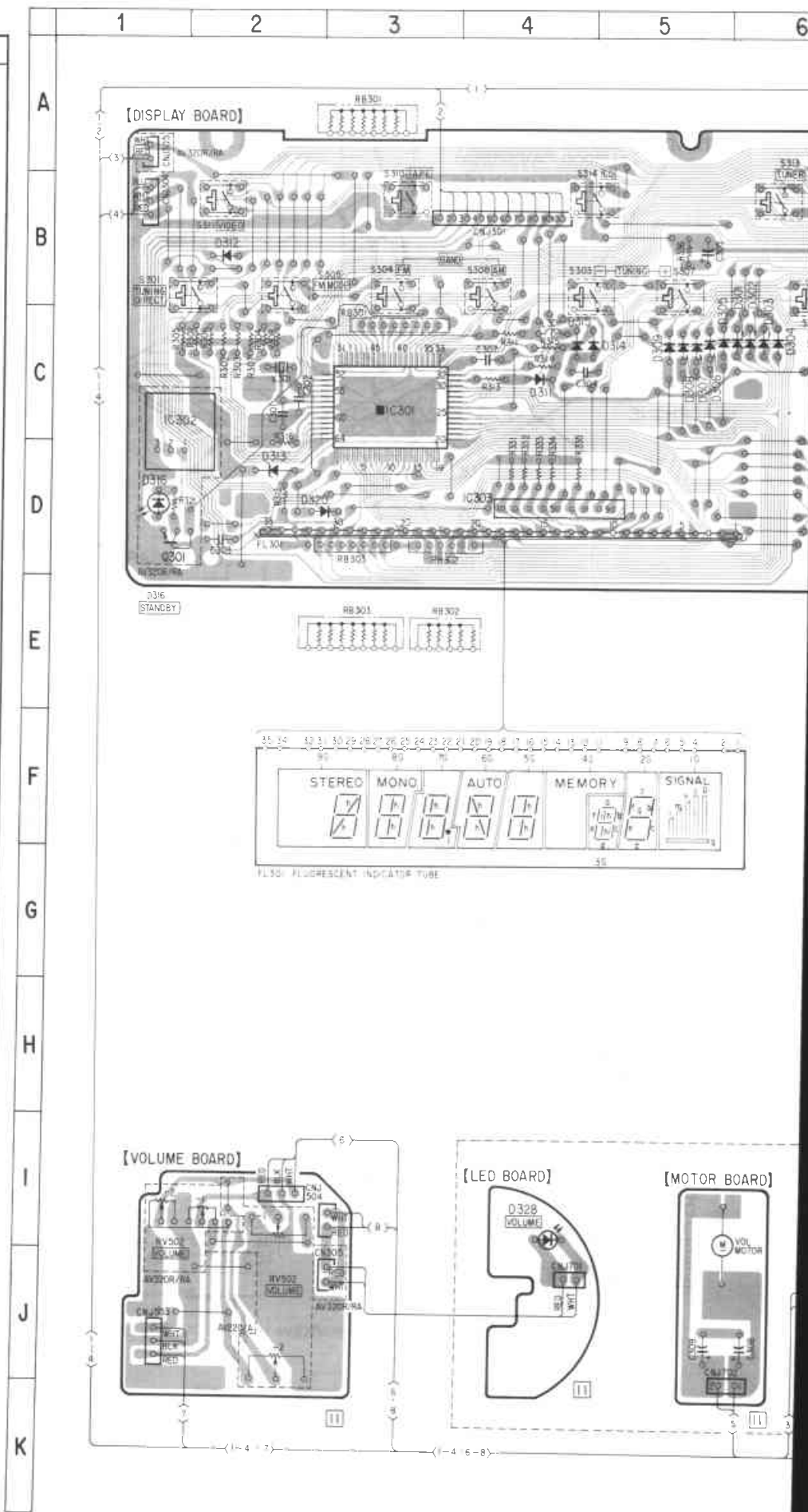

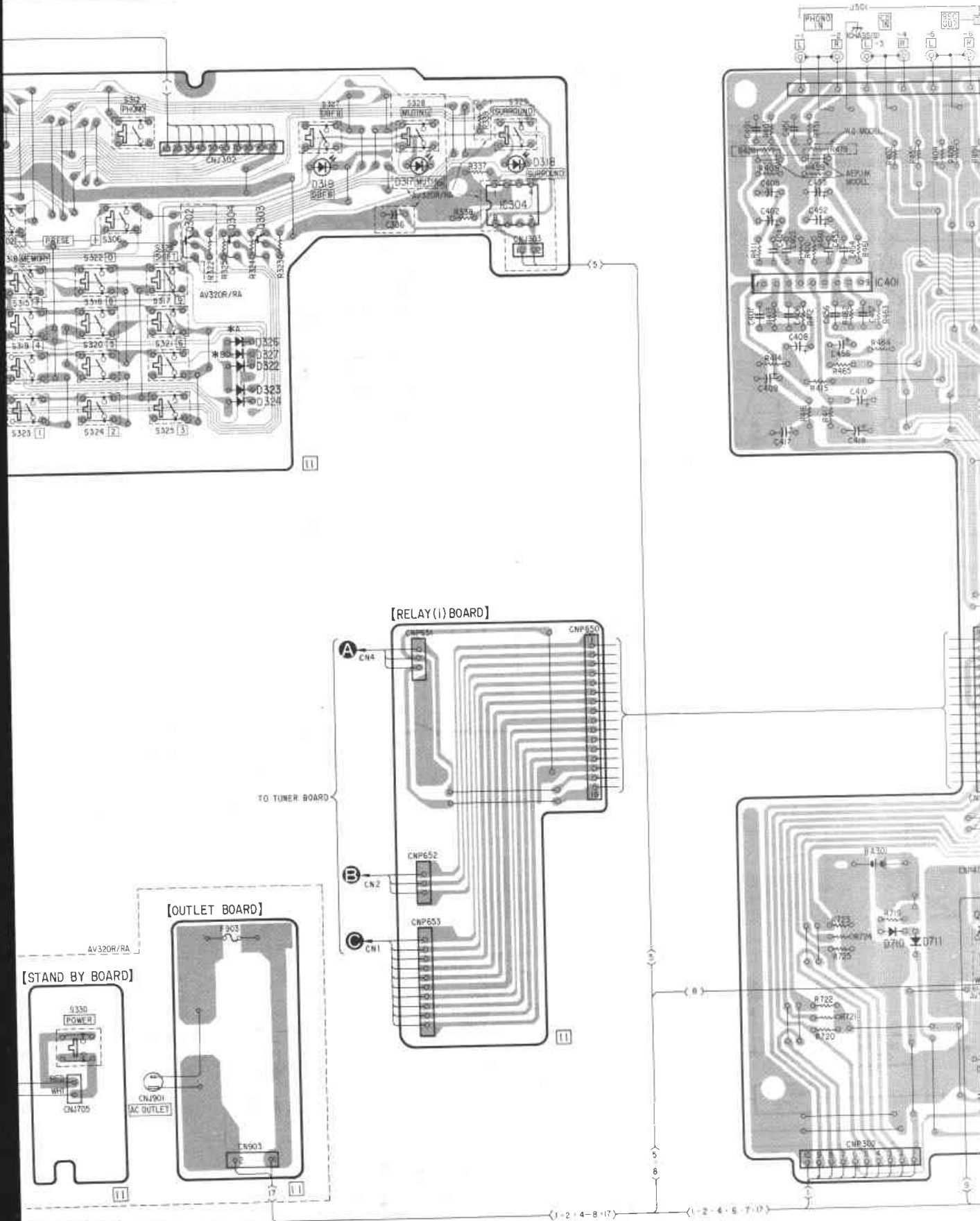

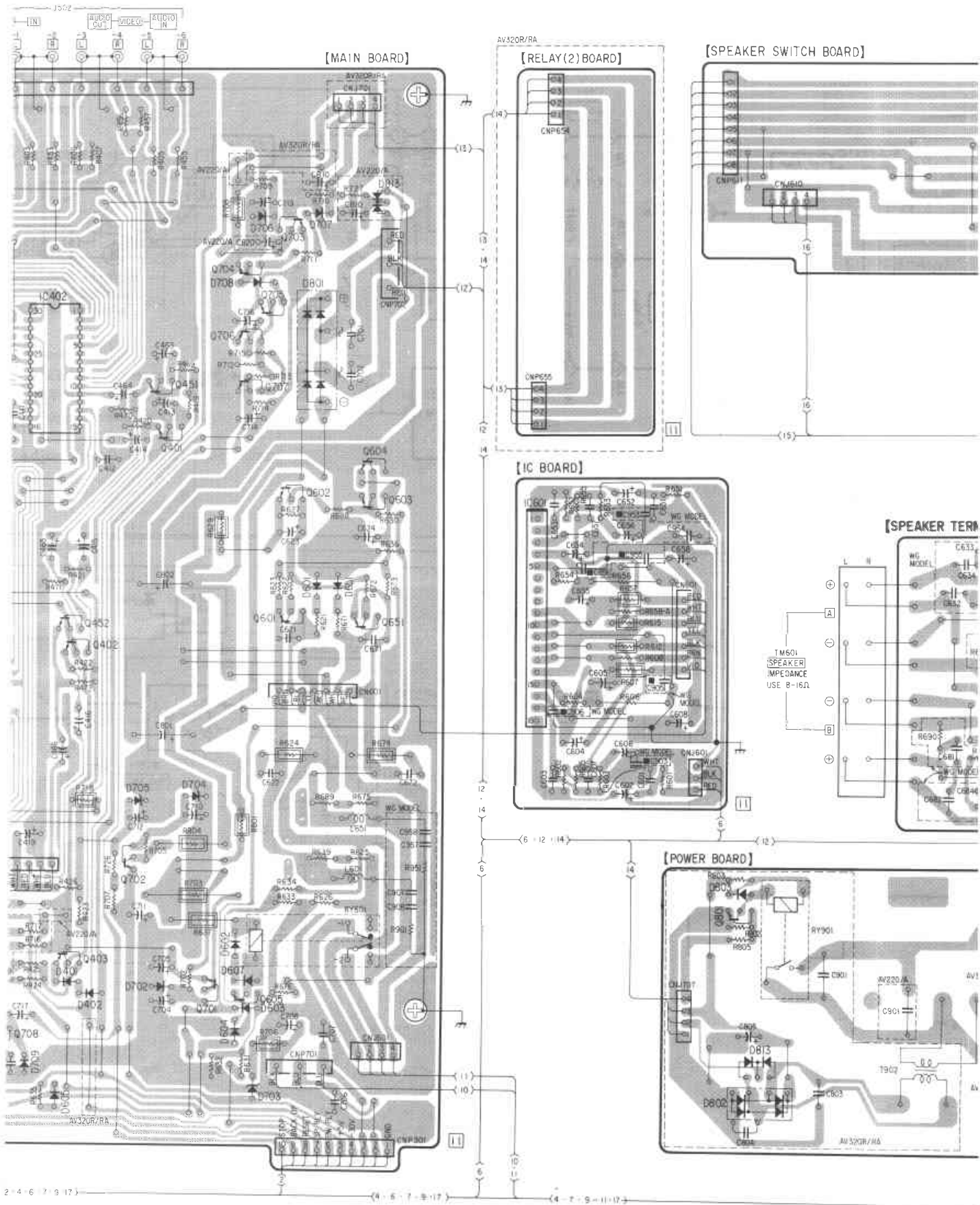

2-4-6-7-9-17

4-5-7-9-17

4-7-9-11-17

[HP BOARD]

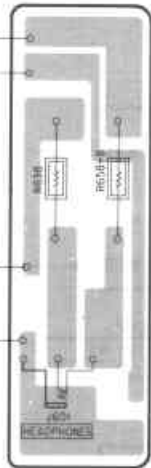

[TONE BOARD]

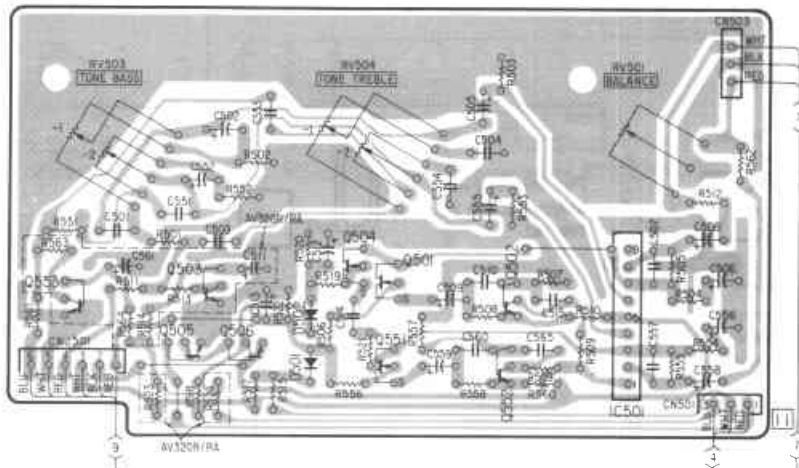

[RELAY(3) BOARD]

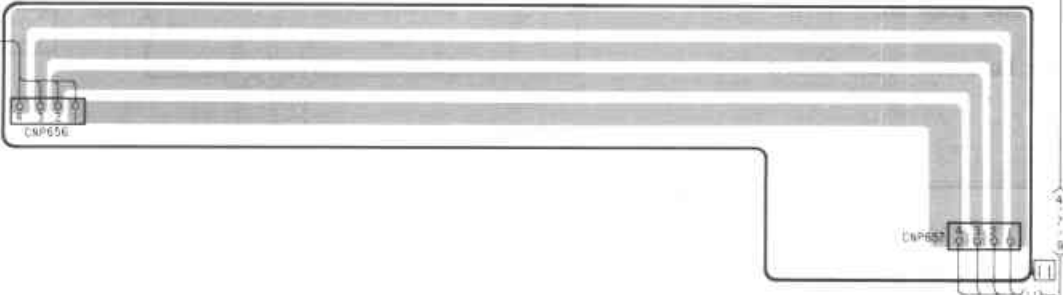

[RELAY(4) BOARD]

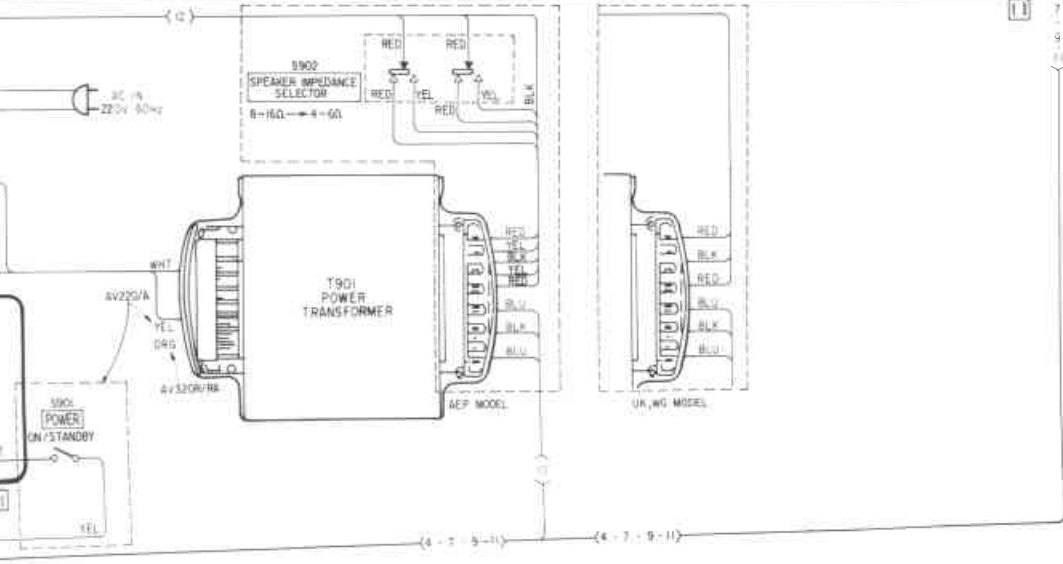







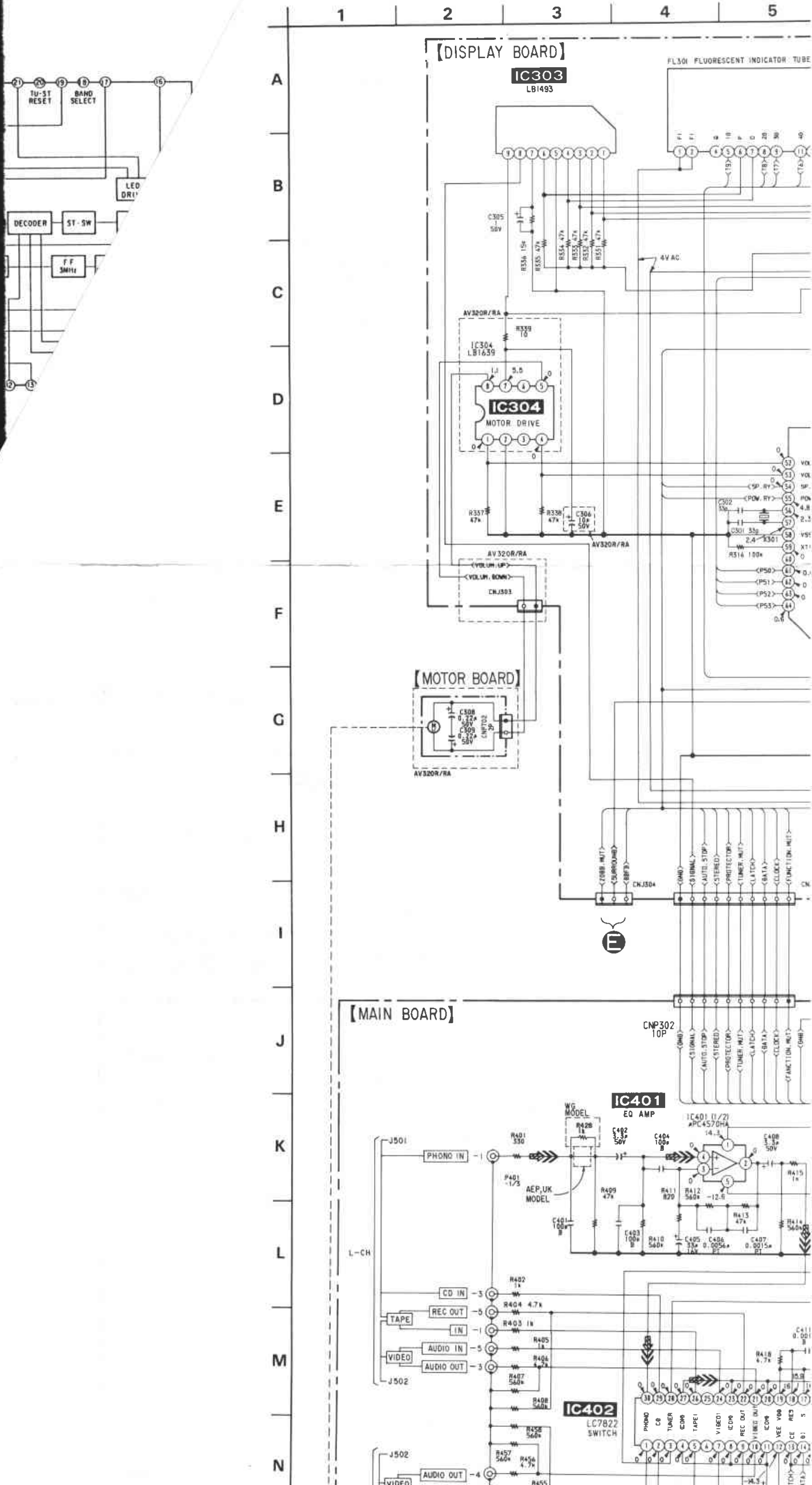



IC81 LC7218

IC50

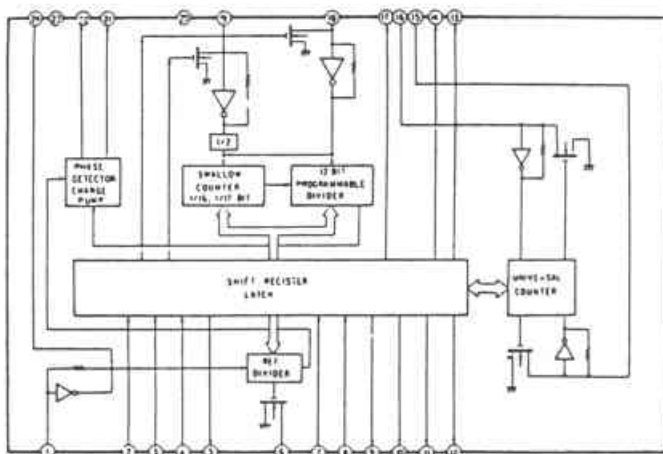
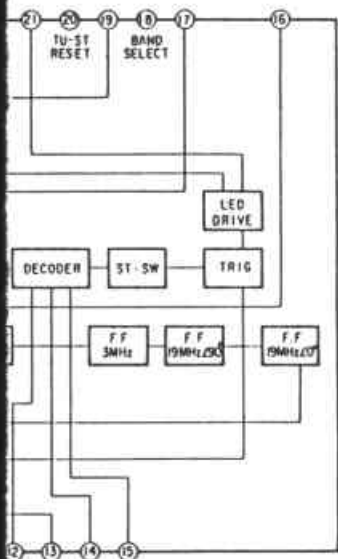

IC303 LB1493

IC5

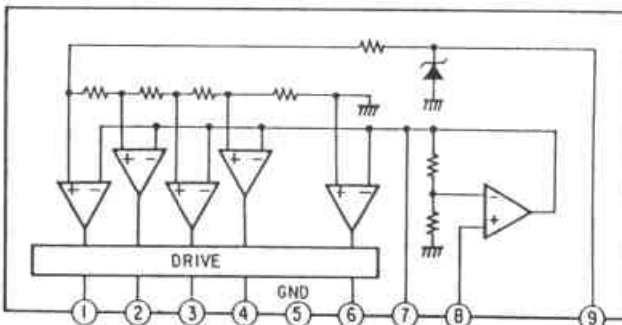

AGRAM - TUNER SECTION -



[TUNER BOARD]

\* : Refer to "Note on Ceramic Filter (CF1, 2) Replacement" on page 4.

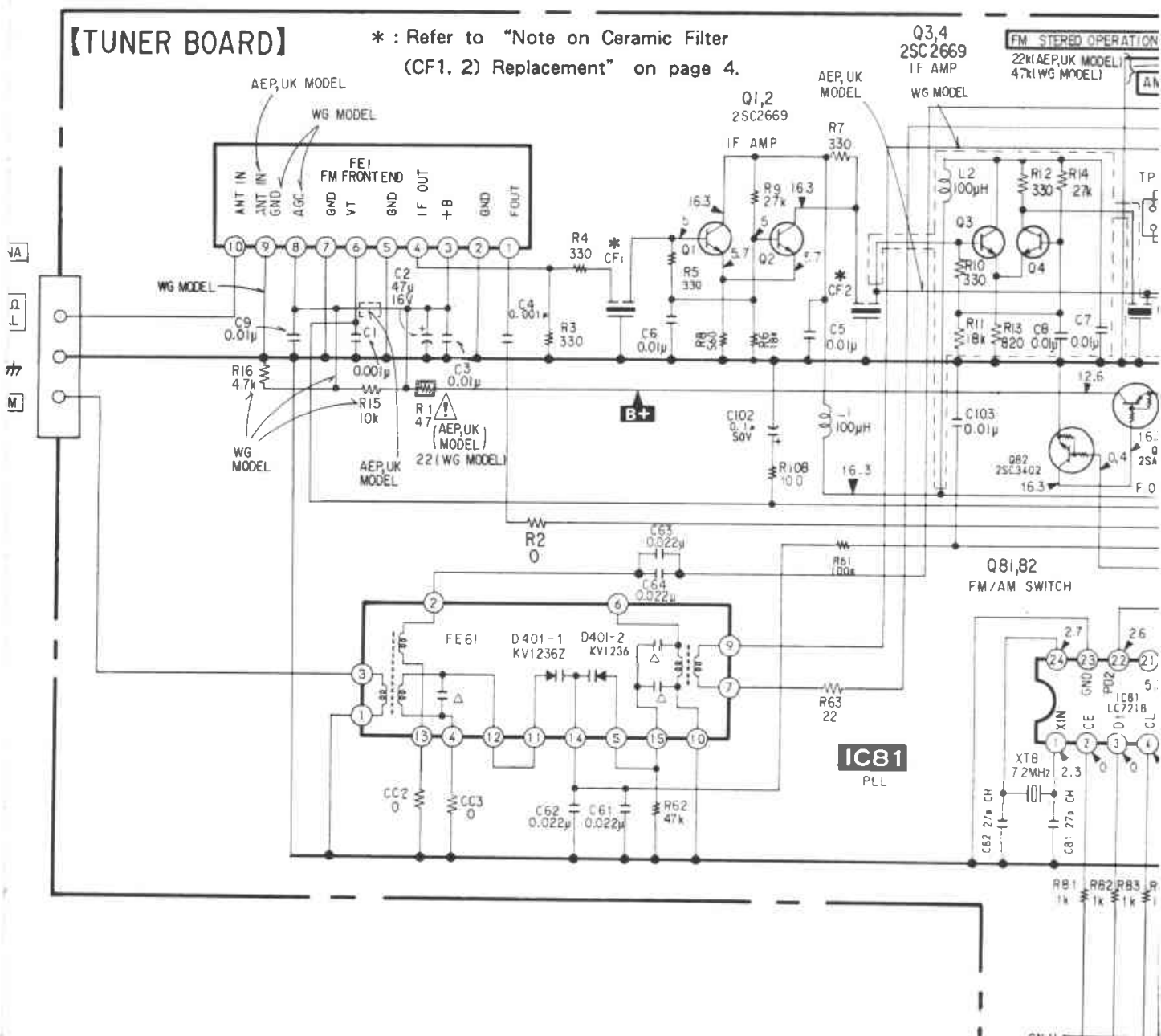

LC7822

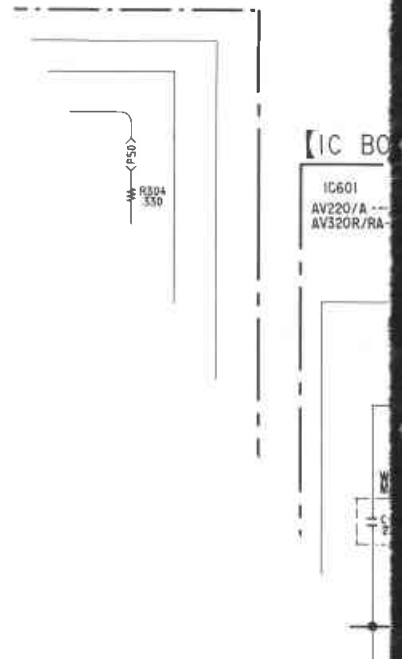
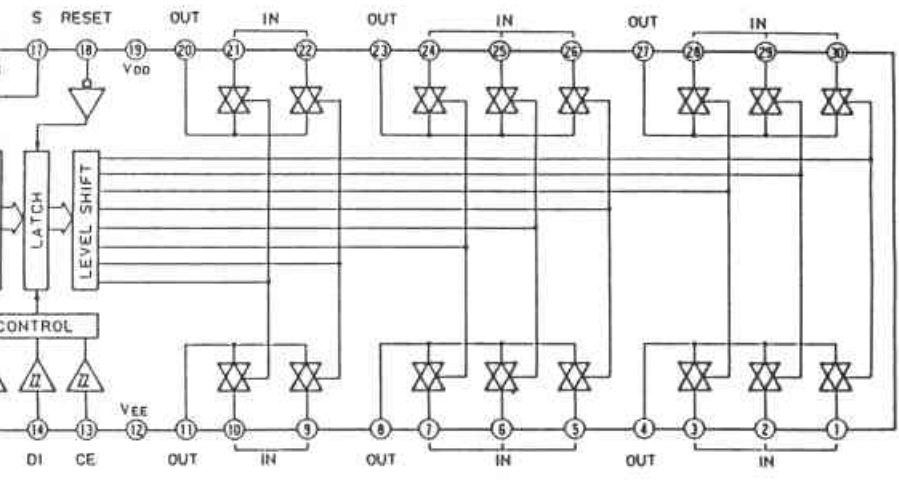

3 LB1639

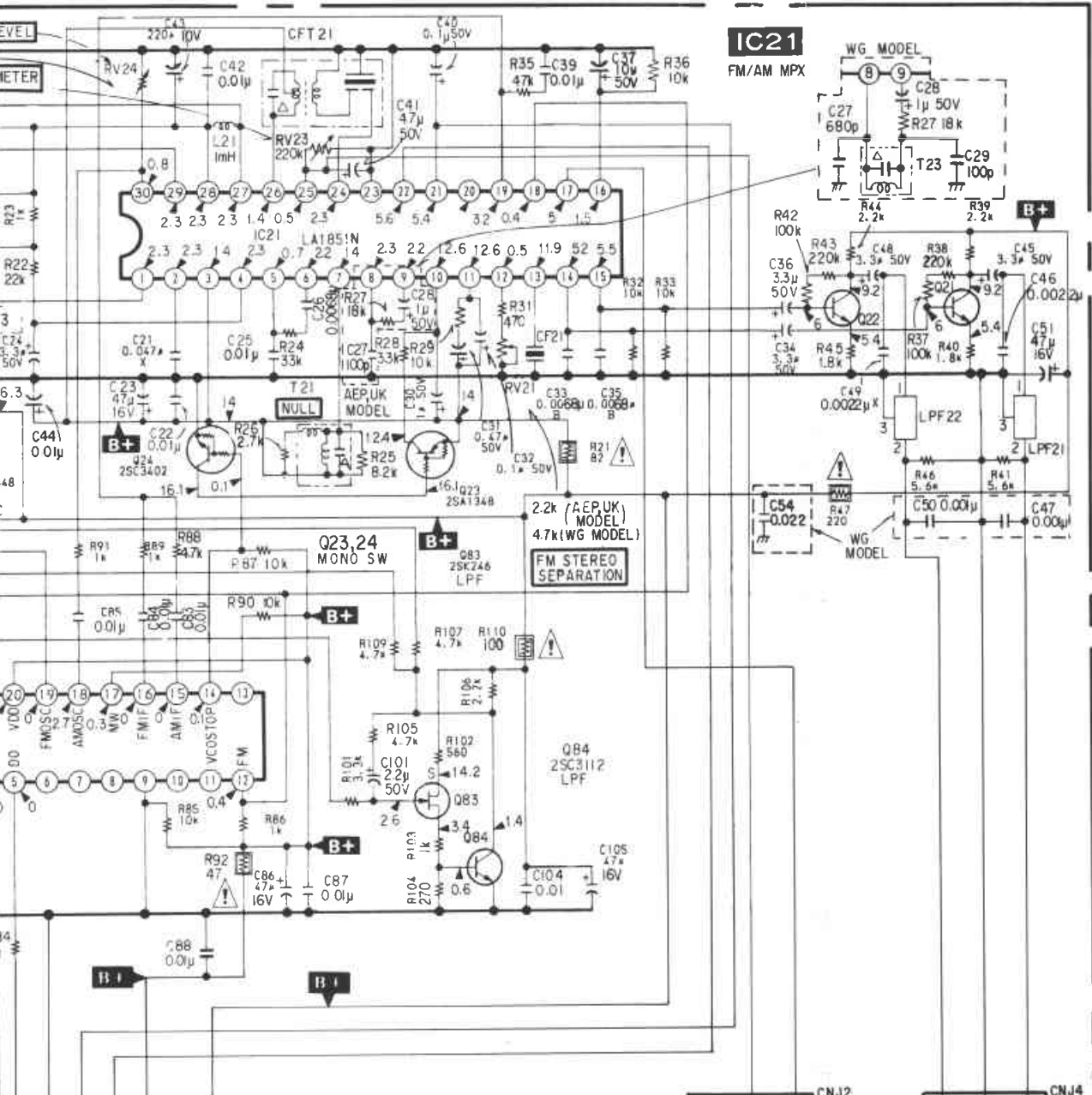
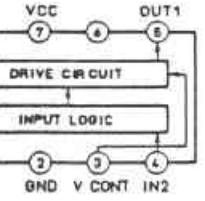

IC21 FM/AM MPX

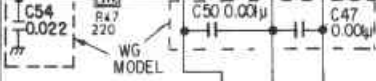
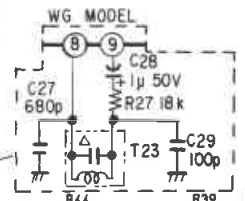

CNJ2

CNJ4

BOARD]

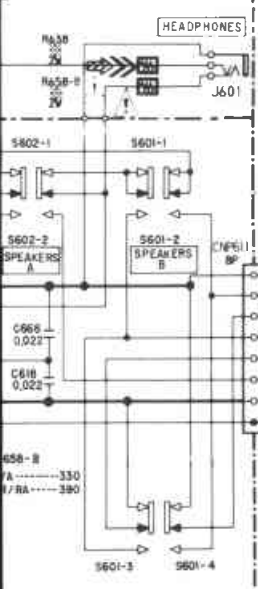

[SP TERMINAL BOARD]

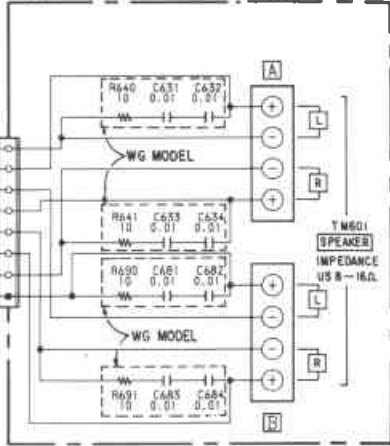

AKER SWITCH BOARD]

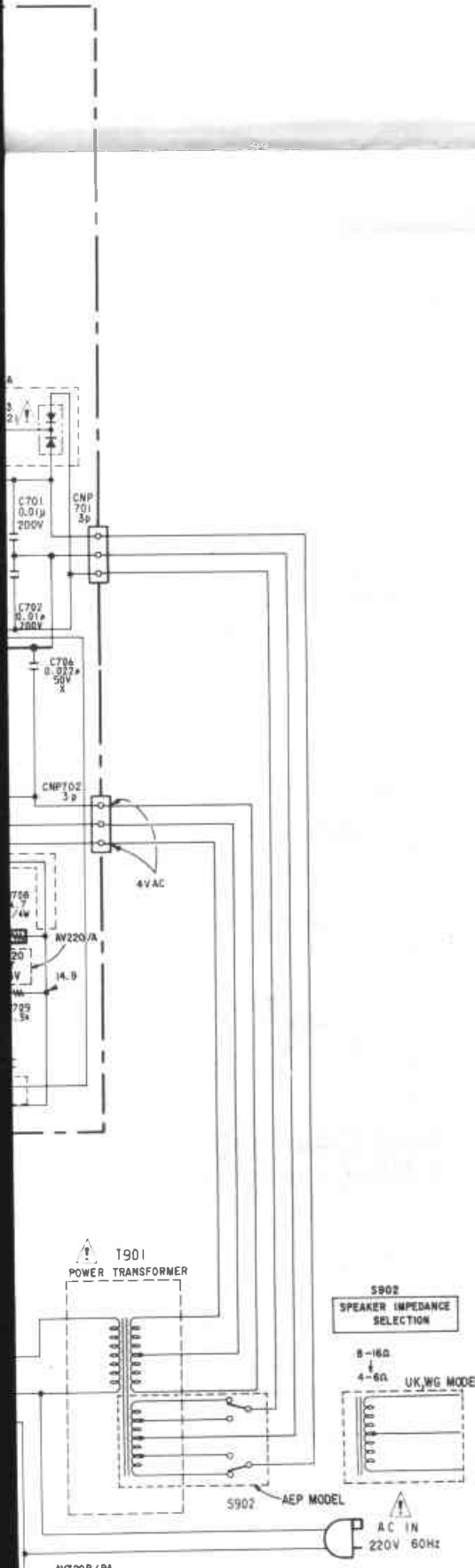

Note :

- \*A, \*B : See Page 4 for Note on Ceramic Filter (CF1, 2 and 3) Replacement.
- All capacitors are in  $\mu F$  unless otherwise noted. pF :  $\mu \mu F$  50WV or less are not indicated except for electrolytics and tantalums.
- All resistors are in  $\Omega$  and  $1/4W$  or less unless otherwise specified.
- % : indicates tolerance.
- $\Delta$  : internal component.
-  : nonflammable resistor.

Note: The components identified by mark  $\Delta$  or dotted line with mark  $\Delta$  are critical for safety. Replace only with part number specified.

— : B+ Line

ARD)

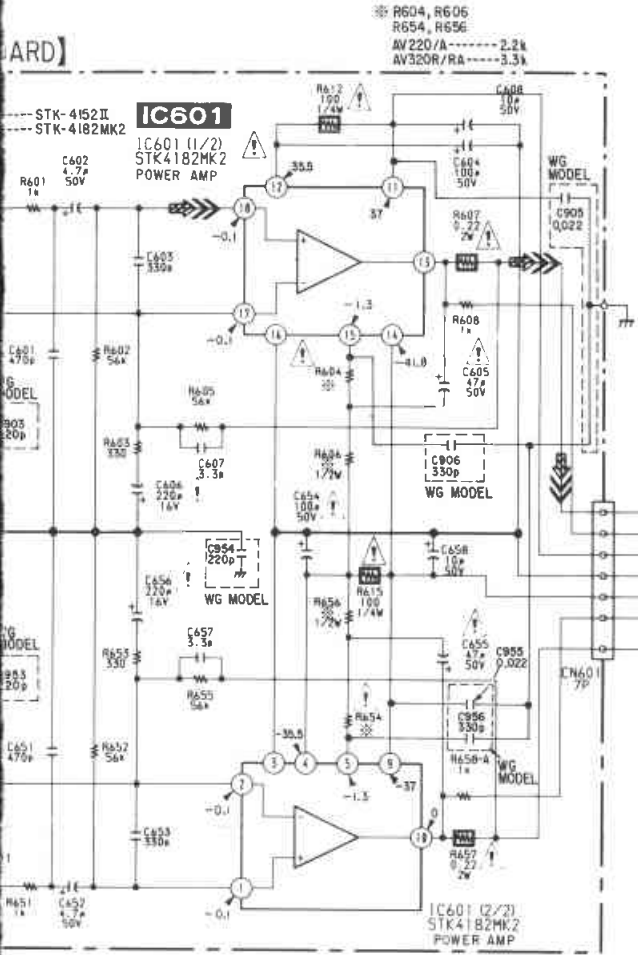

[STAND BY BOARD]

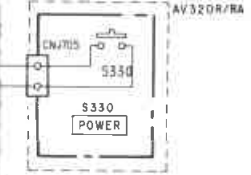

<-30V>  
 <-PPV,RY>  
 <-F>  
 <-RESET>  
 <-F>  
 <-STOP>  
 <-SP,RY>

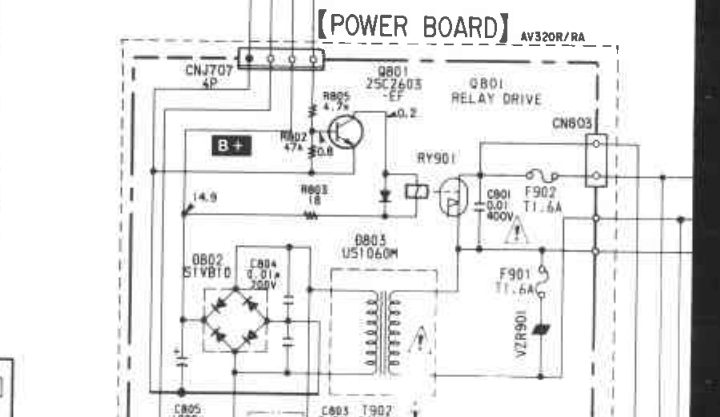
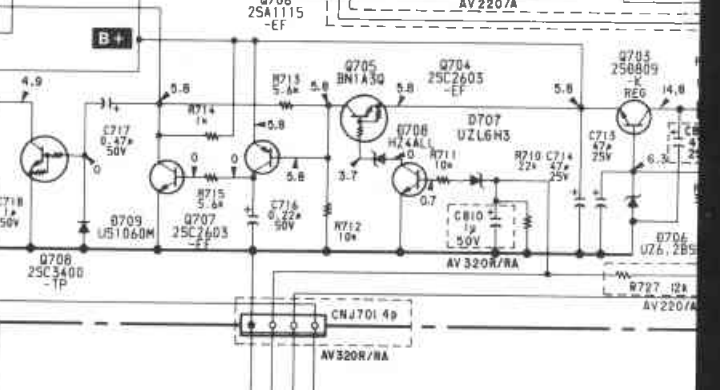
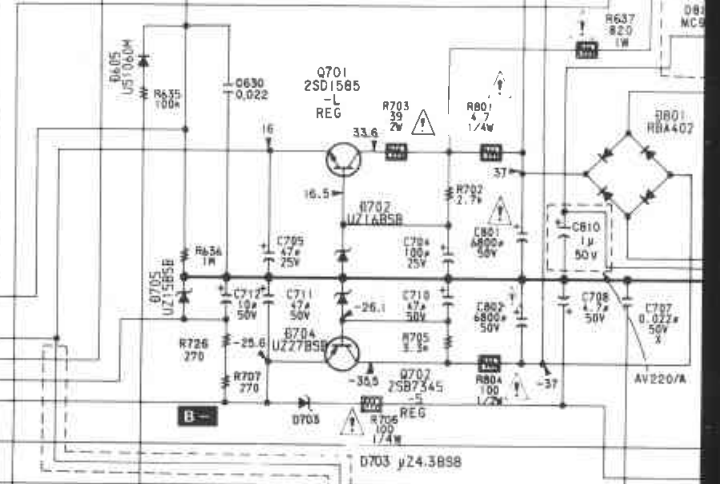
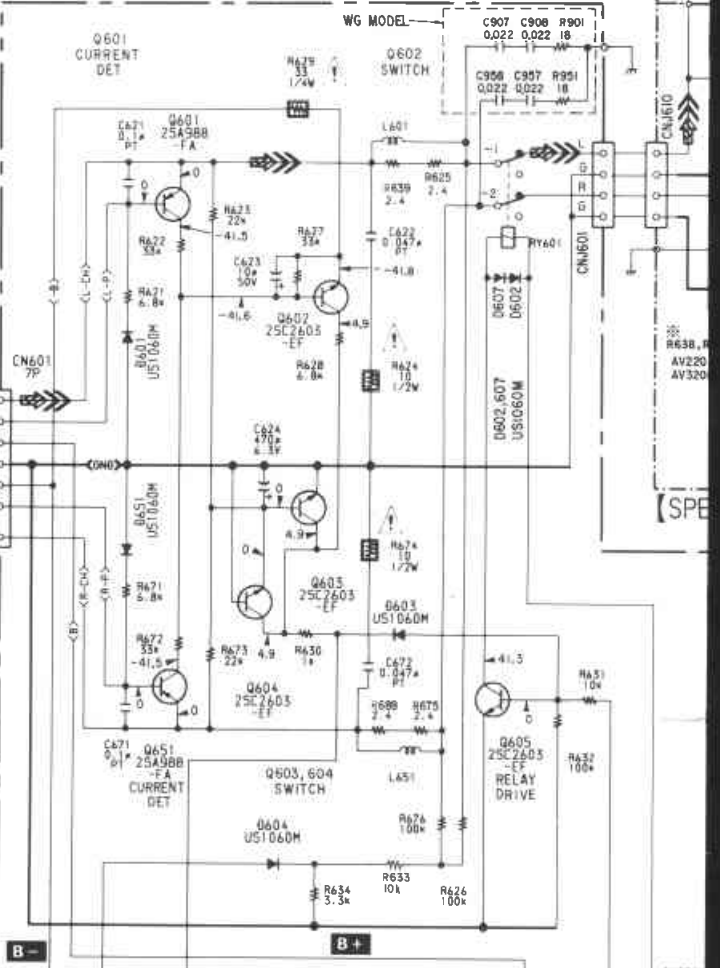
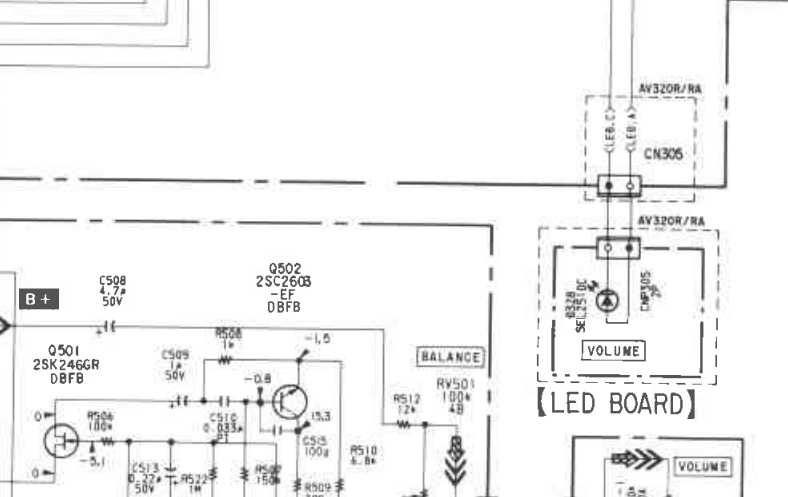
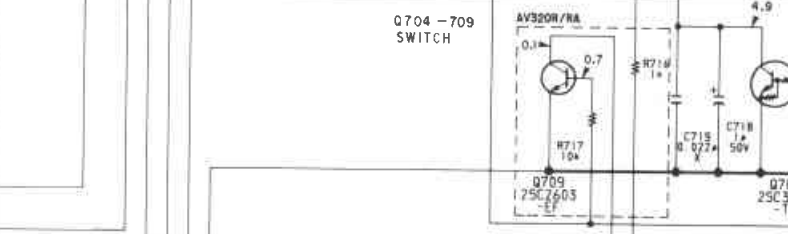

[HP

[SPE

AV220/A

D81 MC9

D801 RBA407

AV220/A

AV220/A

AV220/A

AV220/A

AV220/A

AV220/A

AV220/A

AV220/A

AV220/A

AV220/A

AV220/A

AV220/A

AV220/A

AV220/A

AV220/A

AV220/A

AV220/A

AV220/A

AV220/A

AV220/A

AV220/A

AV220/A

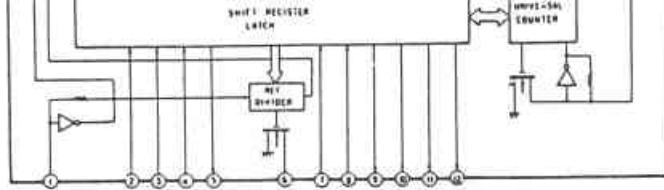
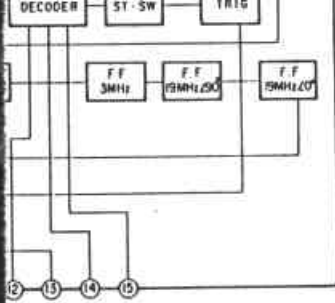

IC303 LB1493

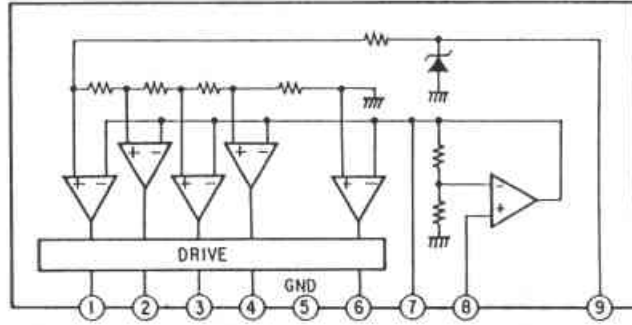

IC50



AGRAM -TUNER SECTION-

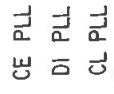
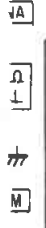
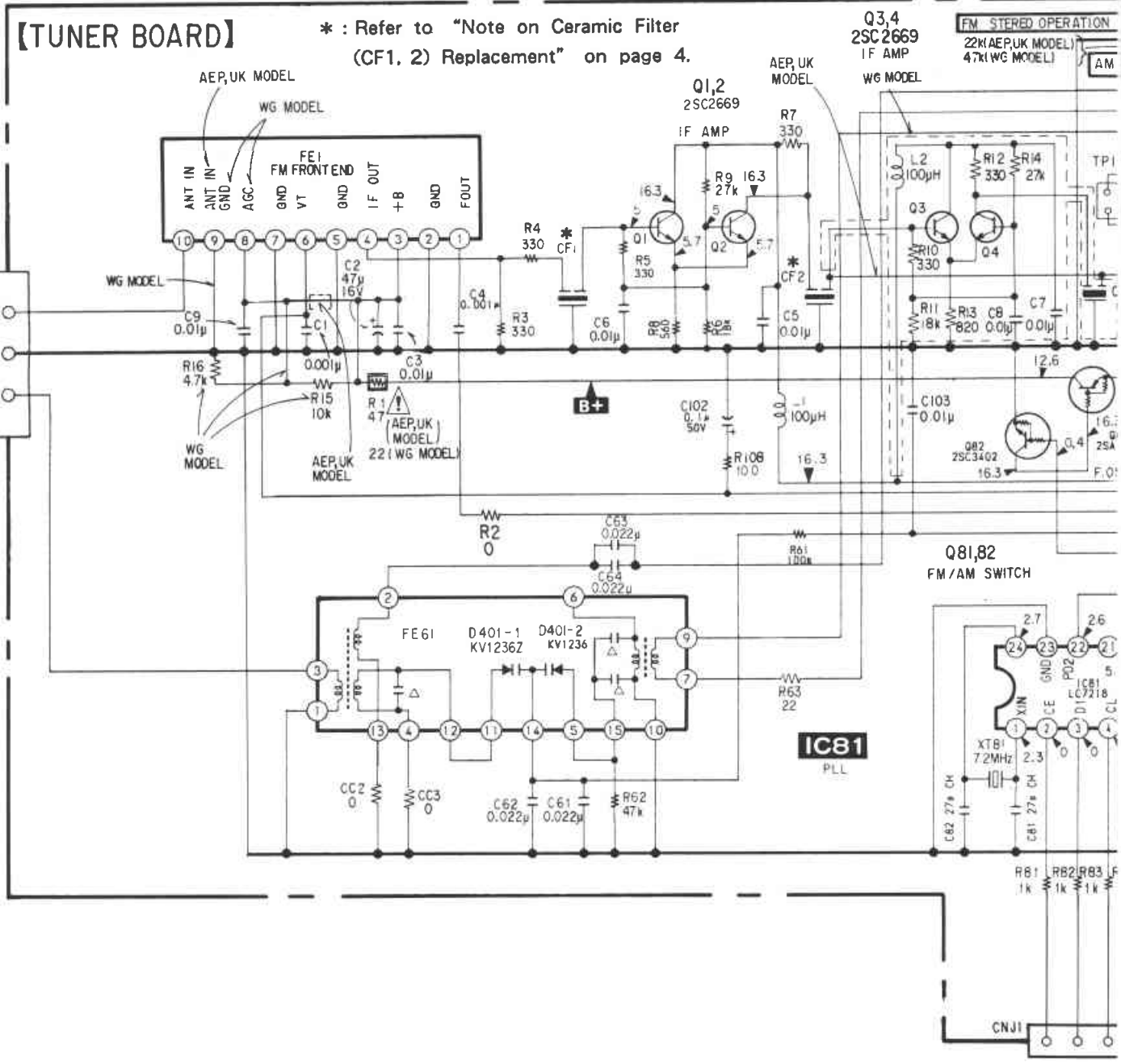

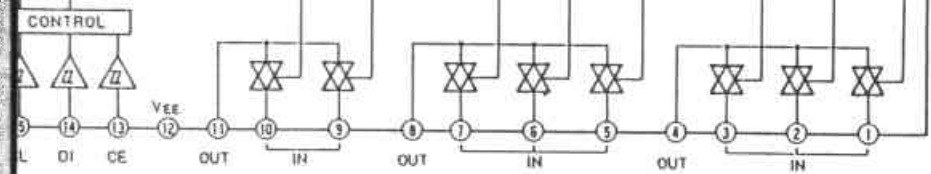

3 LB1639

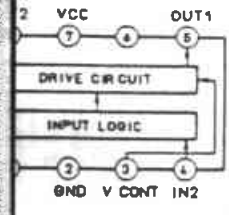

10 11 12 13 14 15 16

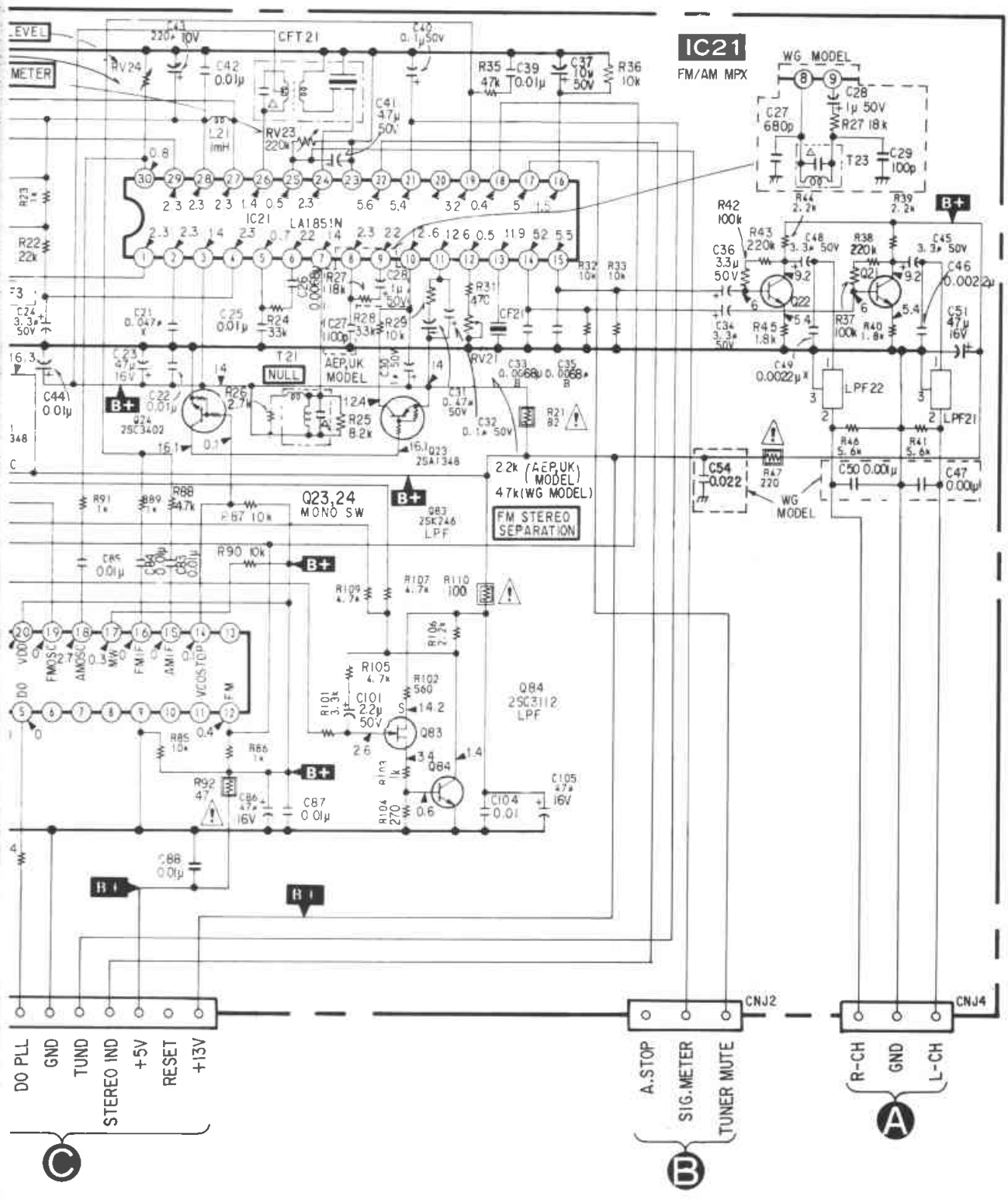

3-5. PRINTED WIRING BOARDS - TUNER SECTION -

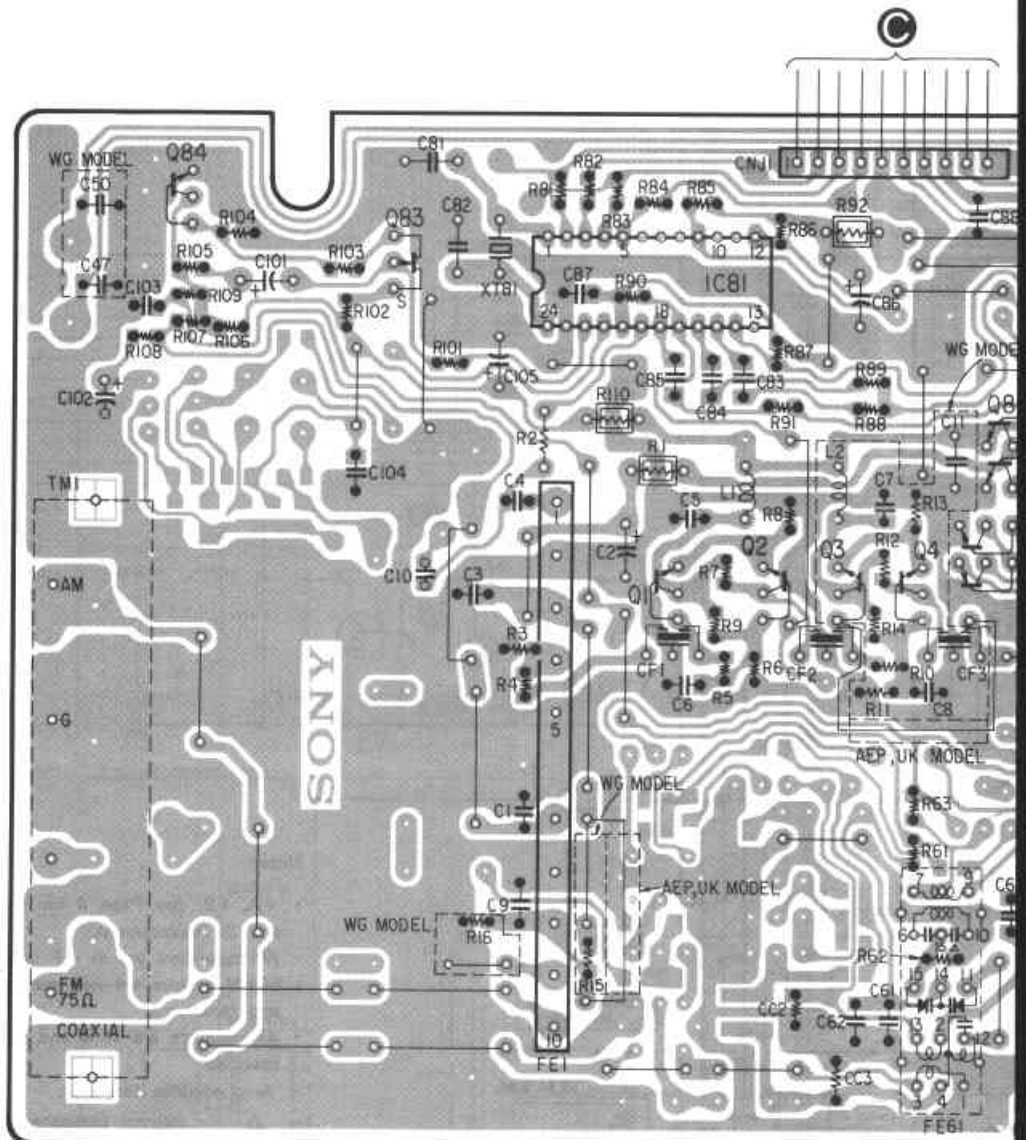

IC21 LA1851N

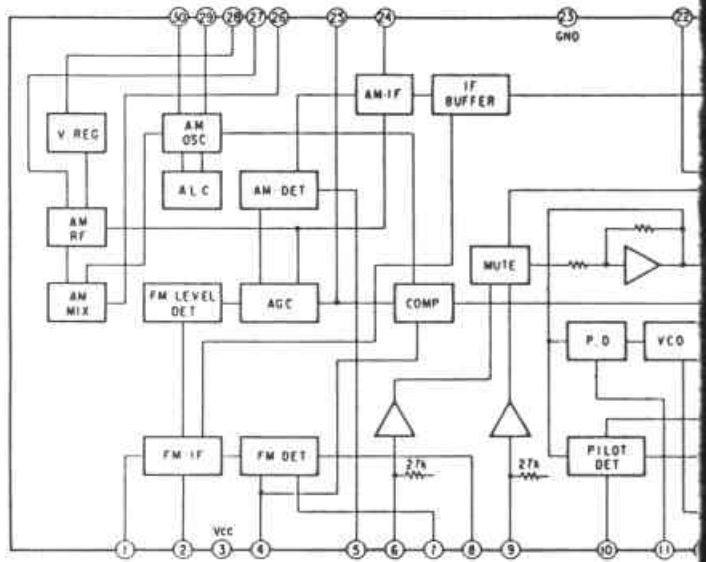

3-6. SCHEMATIC DI

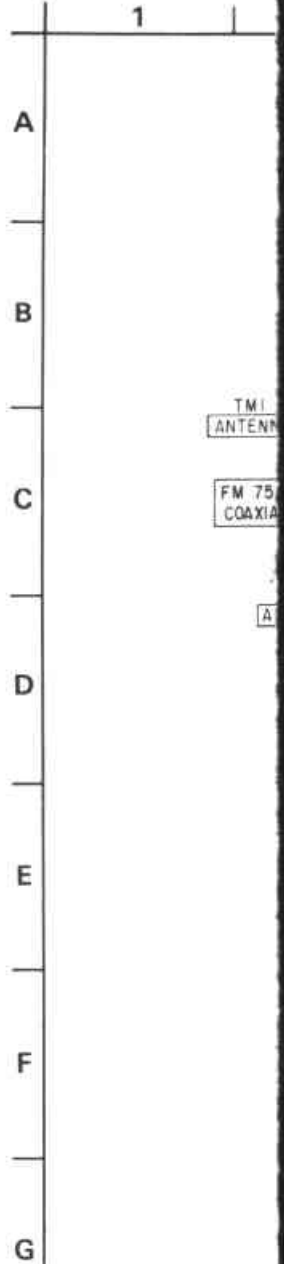
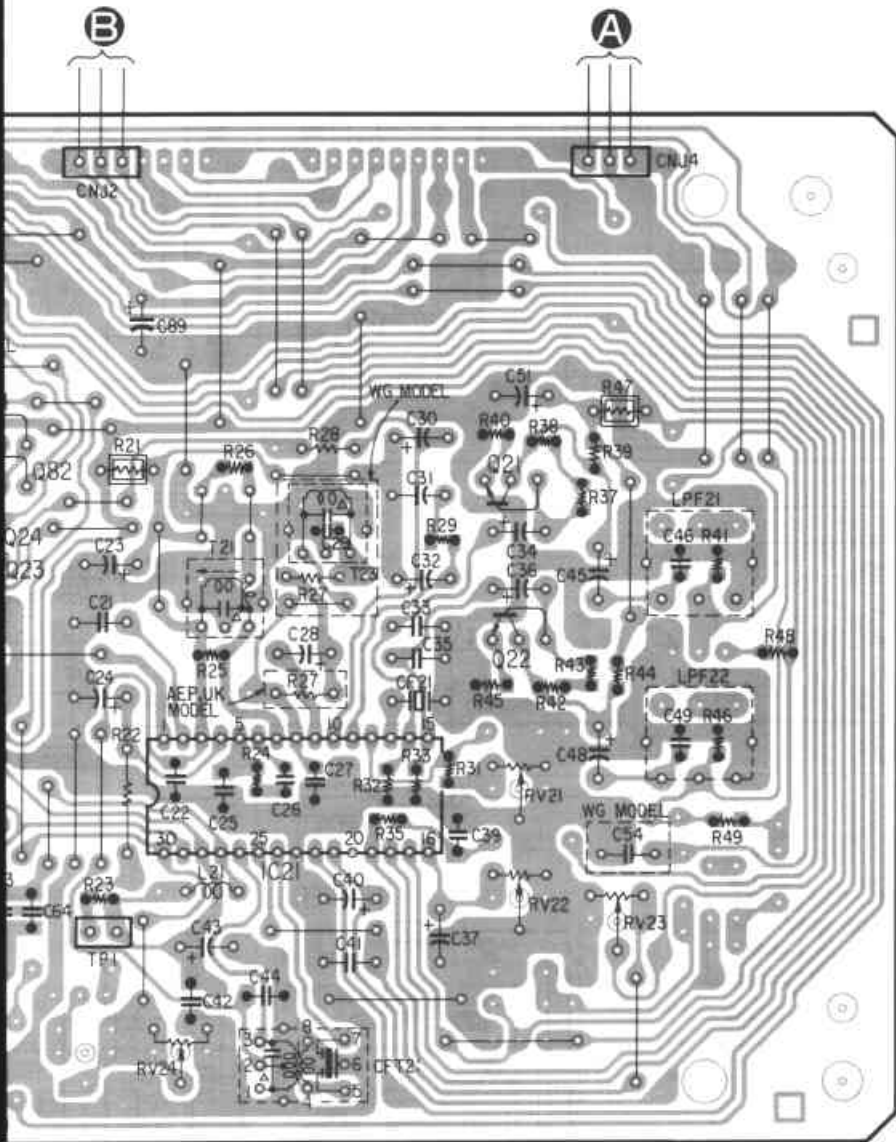



3-7. EXPLANATION OF IC301 ( $\mu$ PD75206)

PIN No.	SIGNAL NAME	FUNCTION	I/O	ACTIVE
1	RESET	Micro Computer RESET	I	L
2	T0	FL tube indication (invalid) digit	O	H
3	T1	FL tube indication digit	T1 O	H
4	T2	FL tube indication digit	T2 O	H
5	T3	FL tube indication digit	T3 O	H
6	T4	FL tube indication digit	T4 O	H
7	T5	FL tube indication digit	T5 O	H
8	T6	FL tube indication digit	T6 O	H
9	T7	FL tube indication digit	T7 O	H
10	T8	FL tube indication digit	T8 O	H
11	T9	FL tube SIGNAL indication digit	T9 O	H
12	T10/PH3	DBFB Output	O	H
13	T11/PH2	IF WIDE/NARROW Output	O	H
14	T12/PH1	Adapter Output	O	H
15	T13/PH0	-20dB Muting Output	O	H
16	T14/S11	FL tube indication Segment/Diode	S11 O	H
17	T15/S10	FL tube indication Segment/Diode	S10 O	H
18	V road	FL tube pulldown power supply	-	-
19	V pre	FL tube driver power supply	-	-
20	S9	FL tube indication Segment/Diode	S9 O	H
21	S8	FL tube indication Segment/Key Scan	S8 O	H
22	S7	FL tube indication Segment/Key Scan	S7 O	H
23	S6	FL tube indication Segment/Key Scan	S6 O	H
24	S5	FL tube indication Segment/Key Scan	S5 O	H
25	S4	FL tube indication Segment/Key Scan	S4 O	H
26	Vdd	Micro Computer power supply	-	-
27	S3	FL tube indication Segment/Key Scan	S3 O	H
28	S2	FL tube indication Segment/Key Scan	S2 O	H
29	S1	FL tube indication Segment/Key Scan	S1 O	H
30	S0	FL tube indication Segment/Key Scan	S0 O	H
31	P00/INT4	Signal to cut power supply	STOP I	L
32	P01/SCK	Serial latch for electrical adjustment use	SI. LAT I	L

-Continued on page 22-

PIN No.	SIGNAL NAME	FUNCTION	I/O	ACTIVE
33	P02/S0	Tuner Auto Stop input ASTP	I	L
34	P03/S1	Tuner Stereo input STEREO	I	L
35	P10/INT0	Remote Control Signal input SIRCS	I	L
36	P11/INT1	Protector input PROTECT	I	L
37	P12/INT2	System Power Key input PKEY	I	L
38	P13/T10	Adapter Mechanical Switch input AKEY	I	H
39	P20	Surround output SURROUND	O	H
40	P21	Video Control A VCRA	O	H
41	P22	Video Control B VCRB	O	H
42	P23/BUZ	Video Inhibit VCRI	O	H
43	P30	Protector Muting PMUT	O	L
44	P31	Source Direct Output	O	H
45	P32	Standby LED Output STANBY	O	H
46	P33	Tuner Muting TMUTE	O	H
47	P60	PLL/7822 Latch PLAT	O	H
48	P61	PLL/7822/SI Data DATA	I/O	H
49	P62	PLL/7822/SI Clock CLOCK	I/O	H
50	P63	IF WIDE/NARROW Display output	O	H
51	P40	Function Muting FMUTE	O	L
52	P41	Motor Volume UP VOL+	O	H
53	P42	Motor Volume DOWN VOL-	O	H
54	P43	Speaker Relay SP. RY	O	H
55	PP0	Power Relay POW. RY	O	H
56	X1	Ceramic Oscillator	-	-
57	X2	Ceramic Oscillator	-	-
58	Vss	Micro Computer GND	-	-
59	XT1	-	-	-
60	XT2	-	-	-
61	P50	P50 Key Scan Input	I	H
62	P51	P51 Key Scan Input	I	H
63	P52	P52 Key Scan Input	I	H
64	P53	P53 Key Scan Input	I	H

## SECTION 4 EXPLODED VIEWS

**NOTE:**

- The mechanical parts with no reference number in the exploded views are not supplied.
- The construction parts of an assembled part are indicated with a collation number in the remark column.
- Items marked "\*" are not stocked since they are seldom required for routine service. Some delay should be anticipated when ordering these items.

- Due to standardization, parts with part number suffix -XX and -X may be different from the parts specified in the components used on the set.

- Color Indication of Appearance Parts  
Example:

(RED) ... KNOB, BALANCE (WHITE)



Cabinet's Color



Parts Color

- WG: West Germany

The components identified by mark or dotted line with mark are critical for safety. Replace only with part number specified.

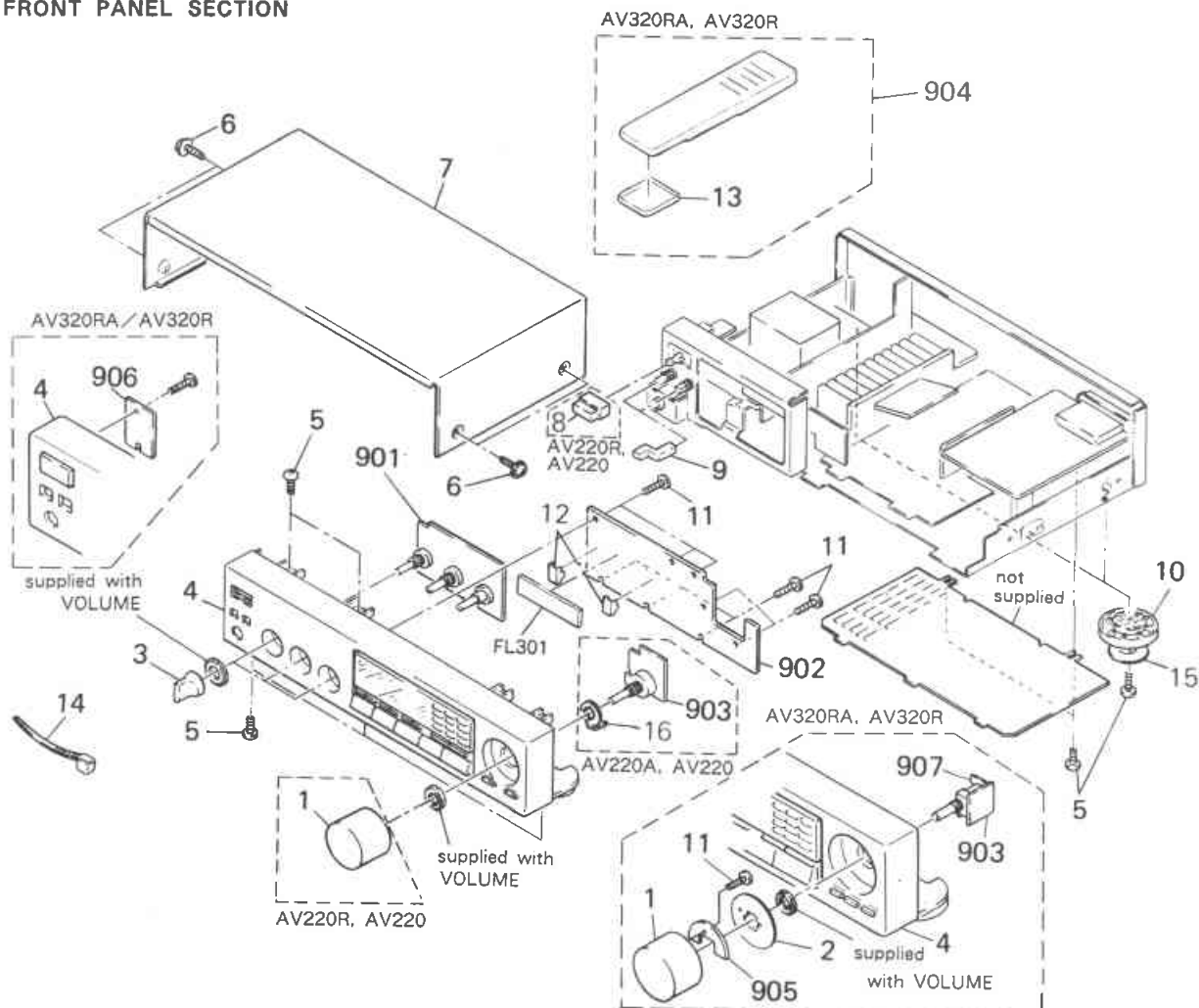
**(1) FRONT PANEL SECTION**

No.	Part No.	Description	Remarks	No.	Part No.	Description	Remarks
1	4-925-121-01	{AV320R/RA}...KNOB (V2)		15	4-923-836-11	CUSHION	
2	4-925-121-71	{AV220/A}...KNOB (V2)		16	*4-925-044-01	{AV220/A}...BRACKET (VOL GROUND)	
3	*4-931-603-01	{AV320R/RA}...SPACER		901	*A-4334-398-A	{AV320R/RA}...MOUNTED PCB, TONE	
4	4-916-745-01	KNOB (DIA.21)			*A-4334-413-A	{AV220/A}...MOUNTED PCB, TONE	
5	X-4906-831-1	{AV320R/RA}...PANEL ASSY, FRONT		902	*A-4334-002-A	{AV220/A}...MOUNTED PCB, DISPLAY	
6	X-4906-834-1	{AV220/A}...PANEL ASSY, FRONT			*A-4334-997-A	{AV320R/RA}...MOUNTED PCB, DISPLAY	
7	7-682-548-04	SCREW +BVT 3X8 (S)		903	*1-634-063-11	PC BOARD, VOLUME	
8	3-704-366-01	SCREW (CASE) (M3X8)		904	1-465-420-11	{AV320R:UK}...REMOTE COMMANDER (RM-U203)	
9	4-925-066-11	CASE			1-465-423-11	{AV320RA,AV320R:WG}...REMOTE COMMANDER (RM-S103)	
10	3-354-912-01	{AV220/A}...KNOB, POWER		905	*1-634-064-11	{AV320R/RA}...PC BOARD, LED	
11	4-906-872-01	KNOB, SQUARE		906	*1-634-068-11	{AV320R/RA}...PC BOARD, STAND BY	
12	X-3304-938-2	FOOT ASSY		907	*1-634-061-11	{AV320R/RA}...PC BOARD, MOTOR	
13	7-685-534-19	SCREW +BTP 2.6X8 TYPE2 N-S		FL301	1-519-509-11	INDICATOR TUBE, FLUORESCENT	
14	*4-924-989-11	HOLDER (FL TUBE)					
15	2-181-754-01	{AV320RA,AV320R:WG}...COVER, BATTERY					
16	4-925-079-01	{AV320R:UK}...COVER(6), BATTERY					
17	3-701-748-00	CLAMP					

(2) CHASSIS SECTION-1

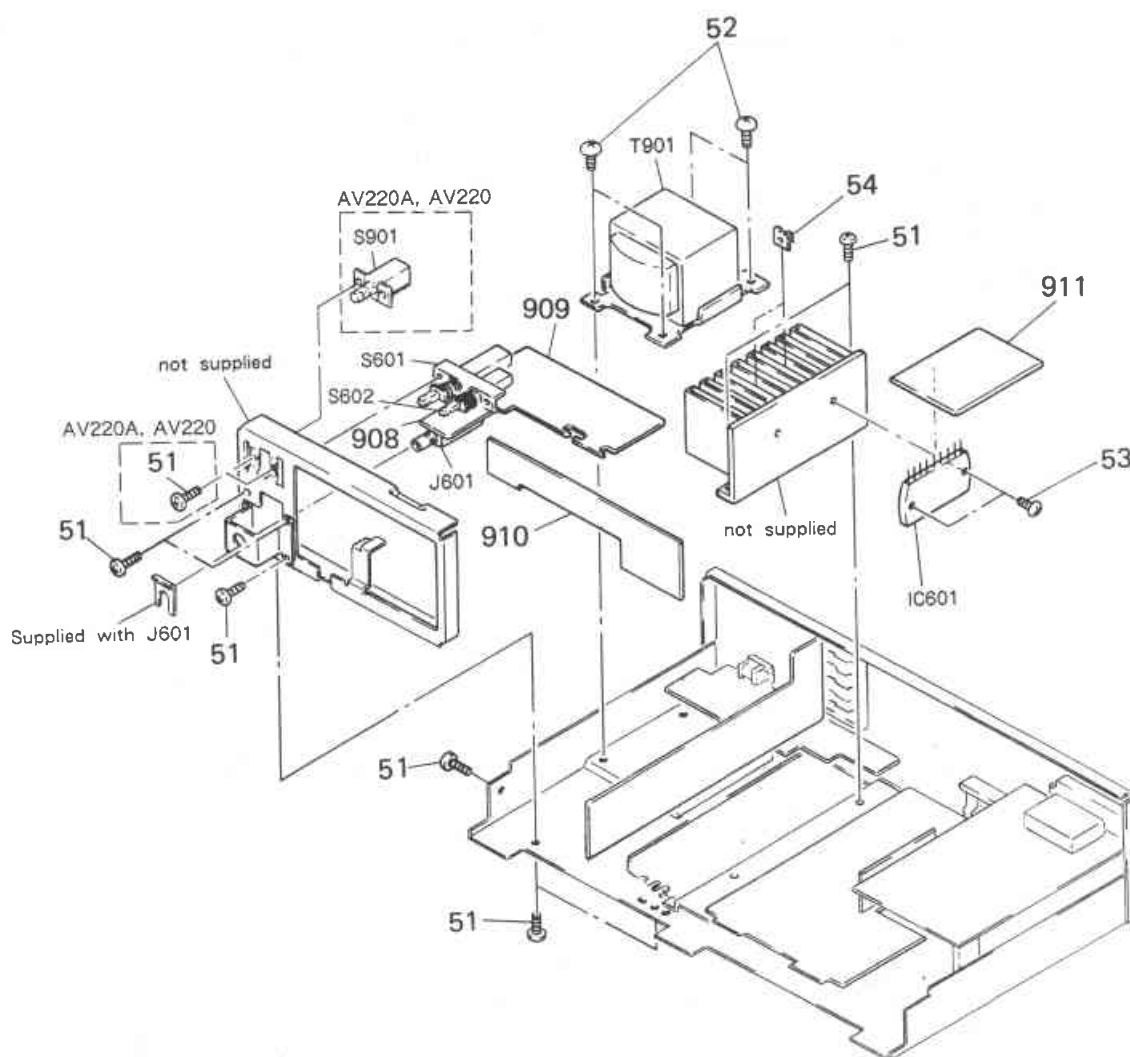







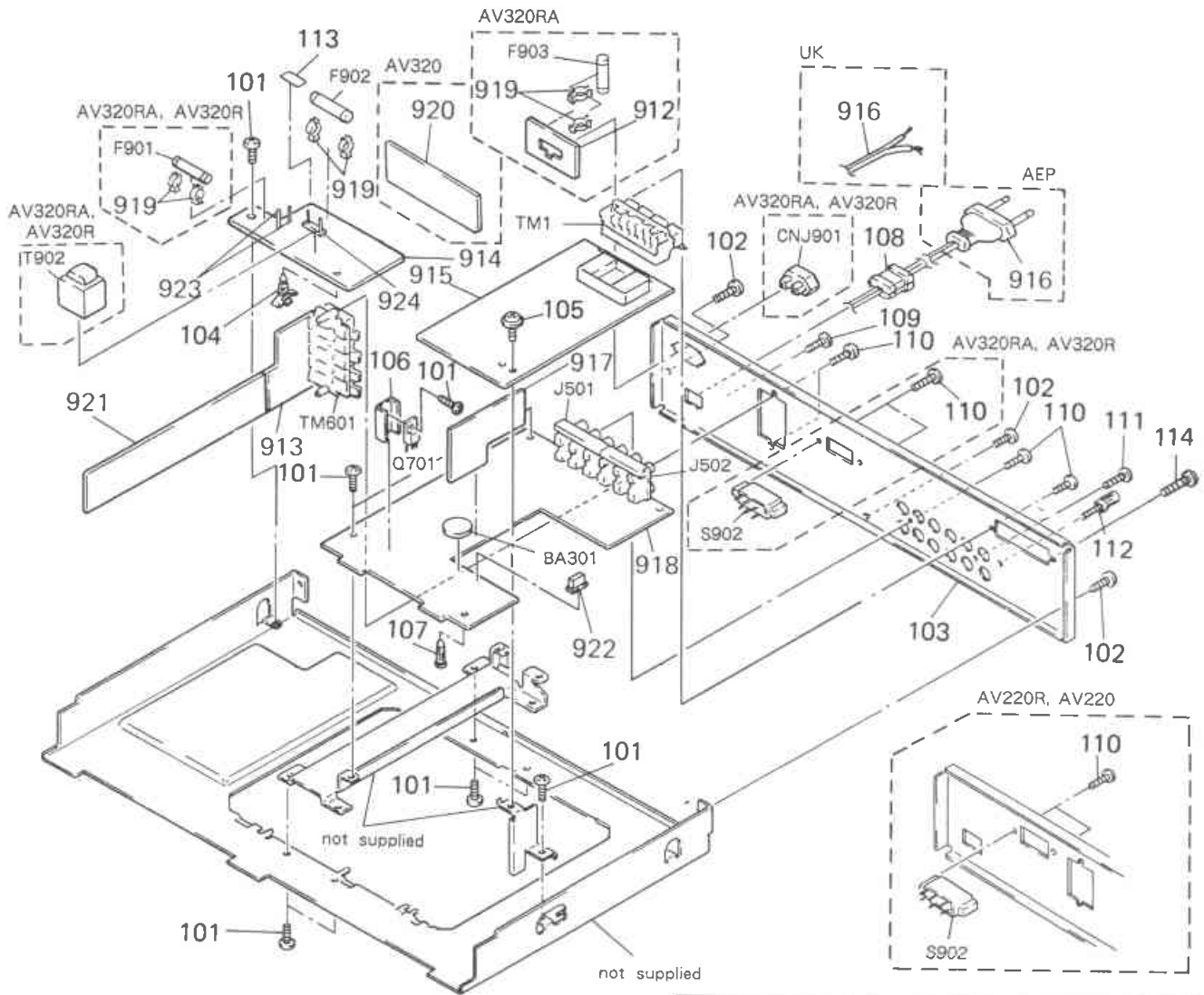



**Note:** The components identified by mark  $\Delta$  or dotted line with mark  $\Delta$  are critical for safety. Replace only with part number specified.

No.	Part No.	Description	Remarks	No.	Part No.	Description	Remarks
51	7-682-548-04	SCREW +BVTT 3X8 (S)		J601	1-507-863-51	JACK, LARGE TYPE (HEADPHONES)	
52	7-682-560-04	SCREW +BVTT 4X6 (S)		S601	1-571-485-11	SWITCH, PUSH (2 KEY)(SPEAKER A)	
53	7-685-650-79	SCREW +BVTP 3X16 TYPE2 N-S		S602	1-571-485-11	SWITCH, PUSH (2 KEY)(SPEAKER B)	
54	*4-881-752-01	(WG)...NUT, PLATE, SPECIAL		S901	$\Delta$ 1-554-685-11	(AV220/A)...SWITCH, PUSH (AC POWER)(1 KEY)	
908	*1-634-070-11	PC BOARD, HEADPHONE		T901	$\Delta$ 1-449-758-11	(AV320R:UK)...TRANSFORMER, POWER	
909	*1-634-069-11	PC BOARD, SPEAKER SWITCH		T901	$\Delta$ 1-449-760-11	(AV320R:WG)...TRANSFORMER, POWER	
910	*1-634-067-11	PC BOARD, RELAY (3)		T901	$\Delta$ 1-449-761-11	(AV220).....TRANSFORMER, POWER	
911	*1-634-060-11	PC BOARD, IC		T901	$\Delta$ 1-450-140-11	(AV320RA).....TRANSFORMER, POWER	
IC601	8-749-900-34	(AV320R/RA)...IC STK4182MK2		T901	$\Delta$ 1-450-141-11	(AV220A).....TRANSFORMER, POWER	
IC601	$\Delta$ 8-749-941-52	(AV220/A)...IC STK4152IT					

(3) CHASSIS SECTION-2



Note: The components identified by mark  or dotted line with mark  are critical for safety. Replace only with part number specified.

No.	Part No.	Description	Remarks	No.	Part No.	Description	Remarks
101	7-682-548-04	SCREW +BVTT 3X8 (S)		917	*1-634-065-11	PC BOARD, RELAY (1)	
102	7-682-548-09	SCREW +BVTT 3X8 (S)		918	*A-4334-070-A	(AV220).....MOUNTED PCB, MAIN	
103	*4-931-096-41	(AV320RA).....PANEL, BACK			*A-4334-073-A	(AV320R:WG).....MOUNTED PCB, MAIN	
	*4-931-096-51	(AV320R:WG).....PANEL, BACK			*A-4334-996-A	(AV320RA,AV320R:UK).....MOUNTED PCB, MAIN	
	*4-931-096-61	(AV220A).....PANEL, BACK			*A-4334-999-A	(AV220A).....MOUNTED PCB, MAIN	
	*4-931-096-71	(AV220).....PANEL, BACK		919	1-533-183-11	HOLDER, FUSE	
	*4-931-096-81	(AV320R:UK).....PANEL, BACK		920	*1-634-066-11	(AV320R/RA)....PC BOARD, RELAY (2)	
104	*3-346-265-11	HOLDER, PC BOARD		921	*1-634-073-11	PC BOARD, RELAY (4)	
105	2-383-566-00	SCREW		922	*1-565-514-11	SOCKET, CONNECTOR 2P	
106	*4-800-403-11	HEAT SINK		923	1-535-416-00	TERMINAL	
107	*3-669-610-00	SPACER		924	*1-560-265-00	BASE POST (U-TYPE)	
108	*3-703-244-00	BUSHING (2104), CORD		BA301	1-528-120-00	BATTERY, LITHIUM (CR-2025)	
109	7-685-647-79	SCREW +BTP 3X10 TYPE2 N-S		CNJ901	 1-526-751-00	(AV320R:UK).....OUTLET, AC(AC OUTLET)	
110	7-685-647-79	SCREW +BVTP 3X10 TYPE2 N-S		CNJ901	 1-526-794-11	(AV320RA,AV320R:WG).....OUTLET, AC(AC OUTLET)	
111	7-621-849-00	SCREW, TAPPING		F901	 1-532-973-11	(AV320R/RA)....FUSE (1.6A)	
112	3-706-165-00	SCREW		F902	 1-532-967-11	(AV220/A).....FUSE (1.25A)	
113	3-701-947-12	(AV220/A)....LABEL (T1.25A), FUSE		F902	 1-532-973-11	(AV320R/RA)....FUSE (1.6A)	
114	3-704-242-01	(WG)....SCREW, TERMINAL, +BVTP CLAW		F903	 1-532-973-11	(AV320R/RA)....FUSE (1.6A)	
912	*1-635-428-11	(AV320R/RA)....PC BOARD, OUTLET		J501	1-565-320-11	JACK, PIN 6P (PHONE/CD/TAPE)	
913	*1-634-071-11	PC BOARD, SPEAKER TERMINAL		J502	1-565-320-11	JACK, PIN 6P (VIDEO/TAPE)	
914	*A-4334-003-A	(AV220/A).....MOUNTED PCB, POWER		Q701	R-729-107-25	TRANSISTOR 2SD1585-L	
	*A-4334-998-A	(AV320R/RA)....MOUNTED PCB, POWER		S902	1-570-046-21	(AEP)....SWITCH, VOLTAGE CHANGE	
915	*A-4303-280-A	(AEP,UK)....MOUNTED PCB, TUNER				(SPEAKER IMPEDANCE SELECTOR)	
	*A-4303-281-A	(WG).....MOUNTED PCB, TUNER		T902	 1-448-523-11	(AV320R/RA)....TRANSFORMER, POWER	
		(TCB007-2JK2)		TM1	*1-537-138-31	(AEP,UK)....TERMINAL BOARD (ANT)	
		(TCB007-2KK2)		TM601	 1-153-706-00	TERMINAL BOARD(SP) (SPEAKER A/B)	
916	 1-555-750-00	(AEP,WG).....CORD, POWER					
	 1-556-035-00	(AV320:UK)....CORD, POWER					

## SECTION 5 ELECTRICAL PARTS LIST

**NOTE:**

- Due to standardization, replacements in the parts list may be different from the parts specified in the diagrams or the components used on the set.
- Items marked "\*" are not stocked since they are seldom required for routine service. Some delay should be anticipated when ordering these items.
- If there are two or more same circuits in a set such as a stereophonic machine, only typical circuit parts may be indicated and capacitors and resistors in other same circuits may be omitted.

**CAPACITORS:**  
MF:  $\mu$ F, PF:  $\mu$ F.

**RESISTORS**  
• All resistors are in ohms.  
• F: nonflammable

**COILS**  
• MMH: mH, UH:  $\mu$ H

**SEMICONDUCTORS**  
In each case, U:  $\mu$ , for example:  
UA...:  $\mu$ A..., UPA...:  $\mu$ PA...,  
UPC...:  $\mu$ PC, UPD...:  $\mu$ PD...  
• WG: West Germany



The components identified by mark or dotted line with mark are critical for safety. Replace only with part number specified.

Ref.No.	Part No.	Description	Ref.No.	Part No.	Description
901	*A-4334-398-A	(AV320R/RA)...MOUNTED PCB, TONE	C7	1-162-440-11	(WG)...CERAMIC MELF 0.01MF 20% 16V
	*A-4334-413-A	(AV220/A)....MOUNTED PCB, TONE	C8	1-162-440-11	(WG)...CERAMIC MELF 0.01MF 20% 16V
			C9	1-162-440-11	CERAMIC MELF 0.01MF 20% 16V
902	*A-4334-002-A	(AV220/A)....MOUNTED PCB, DISPLAY	C10	1-162-516-11	CERAMIC CHIP 100PF 10% 50V
	*A-4334-997-A	(AV320R/RA)...MOUNTED PCB, DISPLAY	C11	1-101-005-00	(WG)...CERAMIC 0.022MF
903	*1-634-063-11	PC BOARD, VOLUME	C21	1-161-021-11	CERAMIC 0.047MF X
904	1-465-420-11	(AV320R:UK)...REMOTE COMMANDER(RM-U203)	C22	1-162-440-11	CERAMIC MELF 0.01MF 20% 16V
	1-465-423-11	(AV320R/RA:AEP,WG) ...REMOTE COMMANDER(RM-S103)	C23	1-124-477-11	ELECT 47MF
			C24	1-123-382-00	ELECT 3.3MF
905	*1-634-064-11	(AV320R/RA)...PC BOARD, LED	C25	1-162-440-11	CERAMIC MELF 0.01MF 20% 16V
906	*1-634-068-11	(AV320R/RA)...PC BOARD, STAND BY	C26	1-162-527-11	CERAMIC CHIP 6800PF 20% 12V
907	*1-634-061-11	(AV320R/RA)...PC BOARD, MOTOR	C27	1-162-521-11	(WG)....CERAMIC CHIP 6800PF 20% 50V
908	*1-634-070-11	PC BOARD, HEADPHONE	C27	1-162-516-11	(AEP,UK)...CERAMIC CHIP 100PF 10% 50V
909	*1-634-069-11	PC BOARD, SPEAKER SWITCH	C28	1-124-791-11	ELECT 1.0MF
910	*1-634-067-11	PC BOARD, RELAY (3)	C30	1-124-791-11	ELECT 1.0MF
911	*1-634-060-11	PC BOARD, 1C	C31	1-124-902-00	ELECT 0.47MF
912	*1-635-428-11	(AV320R/RA)...PC BOARD, OUTLET	C32	1-124-463-00	ELECT 0.1MF
913	*1-634-071-11	PC BOARD, SPEAKER TERMINAL	C33	1-130-481-00	PE TEREPHTHALATE 0.0068MF
914	*A-4334-003-A	(AV220/A)....MOUNTED PCB, POWER	C34	1-123-382-00	ELECT 3.3MF
	*A-4334-998-A	(AV320R/RA)...MOUNTED PCB, POWER	C35	1-130-481-00	PE TEREPHTHALATE 0.0068MF
915	*A-4303-280-A	(AEP,UK) ...MOUNTED PCB, TUNER	C36	1-123-382-00	ELECT 3.3MF
		(TCB007-2JK2)	C37	1-123-875-11	ELECT 10MF
	*A-4303-281-A	(WG)...MOUNTED PCB, TUNER	C39	1-162-440-11	CERAMIC MELF 0.01MF 20% 16V
		(TCB007-2KK2)	C40	1-124-463-00	ELECT 0.1MF
			C41	1-124-927-11	ELECT 4.7MF
916	1-555-750-00	(AEP,WG)....CORD, POWER	C42	1-162-440-11	CERAMIC MELF 0.01MF 20% 16V
	1-556-035-00	(AV320:UK)...CORD, POWER	C43	1-126-176-11	ELECT 220MF
917	*1-634-065-11	PC BOARD, RELAY (1)	C44	1-162-440-11	CERAMIC MELF 0.01MF 20% 16V
918	*A-4334-070-A	(AV220).....MOUNTED PCB, MAIN	C45	1-123-382-00	ELECT 3.3MF
	*A-4334-073-A	(AV320R:WG).....MOUNTED PCB, MAIN	C46	1-162-524-11	CERAMIC CHIP 2200PF 20% 12V
	*A-4334-996-A	(AV320RA,AV320R:UK).... MOUNTED PCB, MAIN	C47	1-162-522-11	(WG)...CERAMIC CHIP 1000PF 20% 25V
	*A-4334-999-A	(AV220A).....MOUNTED PCB, MAIN	C48	1-123-382-00	ELECT 3.3MF
919	1-533-183-11	HOLDER, FUSE	C49	1-162-524-11	CERAMIC CHIP 2200PF 20% 12V
920	*1-634-066-11	(AV320R/RA)...PC BOARD, RELAY (2)	C50	1-162-522-11	(WG)...CERAMIC CHIP 1000PF 20% 12V
921	*1-634-073-11	PC BOARD, RELAY (4)	C51	1-124-477-11	ELECT 47MF
922	*1-565-514-11	SOCKET, CONNECTOR 2P	C54	1-101-005-00	(WG)...CERAMIC 0.022MF
923	1-535-416-00	TERMINAL	C61	1-162-624-11	CERAMIC MELF 22000PF 25V
924	*1-560-265-00	BASE POST (U-TYPE)	C62	1-162-624-11	CERAMIC MELF 22000PF 25V
8A301	1-528-120-00	BATTERY, LITHIUM (CR-2025)	C63	1-162-624-11	CERAMIC MELF 22000PF 25V
C1	1-162-522-11	CERAMIC CHIP 1000PF 20% 25V	C64	1-162-624-11	CERAMIC MELF 22000PF 25V
C2	1-124-477-11	ELECT 47MF	C81	1-102-961-00	CERAMIC 27PF CH
C3	1-162-440-11	CERAMIC MELF 0.01MF 20% 16V	C82	1-102-961-00	CERAMIC 27PF CH
C4	1-162-522-11	CERAMIC CHIP 1000PF 20% 25V	C83	1-162-440-11	CERAMIC MELF 0.01MF 20% 16V
C5	1-162-440-11	CERAMIC MELF 0.01MF 20% 16V			
C6	1-162-440-11	CERAMIC MELF 0.01MF 20% 16V			

Ref.No.	Part No.	Description					Ref.No.	Part No.	Description				
C84	1-162-440-11	CERAMIC MELF	0.01MF				C507	1-101-880-00	CERAMIC	47PF		10%	50V
C85	1-162-440-11	CERAMIC MELF	0.01MF	20%	16V		C508	1-126-163-11	ELECT	4.7MF		20%	50V
C86	1-124-477-11	ELECT	47MF	20%	16V		C509	1-131-347-00	TANTALUM	1MF		10%	25V
C87	1-162-440-11	CERAMIC MELF	0.01MF	20%	16V		C510	1-130-489-00	MYLAR	0.033MF		5%	50V
C88	1-162-440-11	CERAMIC MELF	0.01MF	20%	16V		C511	1-124-791-11	(AV320R/RA)...ELECT	1MF		20%	50V
C101	1-124-925-11	ELECT	2.2MF				C512	1-124-464-11	ELECT	0.22MF		20%	50V
C102	1-124-463-00	ELECT	0.1MF				C513	1-124-464-11	ELECT	0.22MF		20%	50V
C103	1-162-440-11	CERAMIC MELF	0.01MF	20%	16V		C514	1-130-493-00	MYLAR	0.068MF		5%	50V
C104	1-162-440-11	CERAMIC MELF	0.01MF	20%	16V		C515	1-102-106-00	CERAMIC	100PF		10%	50V
C105	1-124-477-11	ELECT	47MF				C551	1-130-489-00	MYLAR	0.033MF		5%	50V
C301	1-162-211-31	CERAMIC	33PF	5%	50V		C552	1-124-250-00	ELECT	0.15MF		20%	50V
C302	1-162-211-31	CERAMIC	33PF	5%	50V		C553	1-130-481-00	MYLAR	0.0068MF		5%	50V
C303	1-161-055-00	CERAMIC	0.022MF	10%	50V		C554	1-130-489-00	MYLAR	0.033MF		5%	50V
C304	1-161-055-00	CERAMIC	0.022MF	10%	50V		C555	1-126-163-11	ELECT	4.7MF		20%	50V
C305	1-124-791-11	ELECT	1MF	20%	50V		C556	1-124-925-11	ELECT	2.2MF		20%	50V
C306	1-123-875-11	(AV320R/RA)					C557	1-101-880-00	CERAMIC	47PF		10%	50V
C307	1-136-746-11	FILM ...ELECT	10MF	20%	50V		C558	1-126-163-11	ELECT	4.7MF		20%	50V
C308	1-124-464-11	(AV320R/RA)					C559	1-131-347-00	TANTALUM	1MF		10%	25V
C309	1-124-464-11	(AV320R/RA)					C560	1-130-489-00	MYLAR	0.033MF		5%	50V
C401	1-102-106-00	CERAMIC	100PF	10%	50V		C561	1-124-791-11	(AV320R/RA)...ELECT	1MF		20%	50V
C402	1-123-382-00	ELECT	3.3MF	20%	50V		C565	1-102-106-00	CERAMIC	100PF		10%	50V
C403	1-102-106-00	CERAMIC	100PF	10%	50V		C601	1-162-286-31	CERAMIC	220PF		10%	50V
C404	1-102-106-00	CERAMIC	100PF	10%	50V		C602	1-124-927-11	ELECT	4.7MF		20%	50V
C405	1-124-963-11	ELECT	33MF	20%	16V		C603	1-162-288-31	CERAMIC	330PF		10%	50V
C406	1-130-480-00	MYLAR	0.0056MF	5%	50V		C604	1-124-122-11	ELECT	100MF		20%	50V
C407	1-130-473-00	MYLAR	0.0015MF	5%	50V		C605	1-124-910-11	ELECT	47MF		20%	50V
C408	1-123-382-00	ELECT	3.3MF	20%	50V		C606	1-124-120-11	ELECT	220MF		20%	16V
C409	1-124-477-11	ELECT	47MF	20%	25V		C607	1-162-193-31	CERAMIC	3.3PF		10%	50V
C410	1-124-477-11	ELECT	47MF	20%	25V		C608	1-123-875-11	ELECT	10MF		20%	50V
C411	1-102-074-00	CERAMIC	0.001MF	10%	50V		C618	1-161-055-00	CERAMIC	0.022MF		10%	25V
C412	1-102-106-00	CERAMIC	100PF	10%	50V		C621	1-130-495-00	MYLAR	0.1MF		5%	50V
C413	1-124-927-11	ELECT	4.7MF	20%	50V		C622	1-130-491-00	MYLAR	0.047MF		5%	50V
C414	1-123-382-00	ELECT	3.3MF	20%	50V		C623	1-123-875-11	ELECT	10MF		20%	50V
C415	1-123-382-00	ELECT	3.3MF	20%	50V		C624	1-124-472-11	ELECT	470MF		20%	6.3V
C416	1-123-875-11	ELECT	10MF	20%	50V		C630	1-161-055-00	CERAMIC	0.022MF		10%	50V
C417	1-124-478-11	ELECT	100MF	20%	25V		C631	1-161-051-00	(WG)...CERAMIC	0.01MF		10%	50V
C418	1-124-478-11	ELECT	100MF	20%	25V		C632	1-161-051-00	(WG)...CERAMIC	0.01MF		10%	50V
C419	1-124-478-11	ELECT	100MF	20%	25V		C633	1-161-051-00	(WG)...CERAMIC	0.01MF		10%	50V
C451	1-102-106-00	CERAMIC	100PF	10%	50V		C634	1-161-051-00	(WG)...CERAMIC	0.01MF		10%	50V
C452	1-123-382-00	ELECT	3.3MF	20%	50V		C651	1-162-286-31	CERAMIC	220PF		10%	50V
C453	1-102-106-00	CERAMIC	100PF	10%	50V		C652	1-124-927-11	ELECT	4.7MF		20%	50V
C454	1-102-106-00	CERAMIC	100PF	10%	50V		C653	1-162-288-31	CERAMIC	330PF		10%	50V
C455	1-124-963-11	ELECT	33MF	20%	16V		C654	1-124-122-11	ELECT	100MF		20%	50V
C456	1-130-480-00	MYLAR	0.0056MF	5%	50V		C655	1-124-910-11	ELECT	47MF		20%	50V
C457	1-130-473-00	MYLAR	0.0015MF	5%	50V		C656	1-124-120-11	ELECT	220MF		20%	16V
C458	1-123-382-00	ELECT	3.3MF	20%	50V		C657	1-162-193-31	CERAMIC	3.3PF		10%	50V
C463	1-126-163-11	ELECT	4.7MF	20%	50V		C658	1-123-875-11	ELECT	10MF		20%	50V
C464	1-123-382-00	ELECT	3.3MF	20%	50V		C668	1-161-055-00	CERAMIC	0.022MF		10%	25V
C465	1-123-382-00	ELECT	3.3MF	20%	50V		C671	1-130-495-00	MYLAR	0.1MF		5%	50V
C466	1-123-875-11	ELECT	10MF	20%	50V		C672	1-130-491-00	MYLAR	0.047MF		5%	50V
C501	1-130-489-00	MYLAR	0.033MF	5%	50V		C681	1-161-051-00	(WG)...CERAMIC	0.01MF		10%	50V
C502	1-124-250-00	ELECT	0.15MF	20%	50V		C682	1-161-051-00	(WG)...CERAMIC	0.01MF		10%	50V
C503	1-130-481-00	MYLAR	0.0068MF	5%	50V		C683	1-161-051-00	(WG)...CERAMIC	0.01MF		10%	50V
C504	1-130-489-00	MYLAR	0.033MF	5%	50V		C701	1-106-367-00	MYLAR	0.01MF		5%	200V
C505	1-126-163-11	ELECT	4.7MF	20%	50V								
C506	1-124-925-11	ELECT	2.2MF	20%	50V								

Ref.No.	Part No.	Description				
C702	1-106-367-00	MYLAR	0.01MF	5%	200V	
C704	1-124-478-11	ELECT	100MF	20%	25V	
C705	1-124-477-11	ELECT	47MF	20%	25V	
C706	1-161-055-00	CERAMIC	0.022MF	10%	50V	
C707	1-161-055-00	CERAMIC	0.022MF	10%	50V	
C708	1-124-927-11	ELECT	4.7MF	20%	50V	
C710	1-124-910-11	ELECT	47MF	20%	50V	
C711	1-124-910-11	ELECT	47MF	20%	50V	
C712	1-123-875-11	ELECT	10MF	20%	50V	
C713	1-124-477-11	ELECT	47MF	20%	25V	
C714	1-124-477-11	ELECT	47MF	20%	25V	
C716	1-124-464-11	ELECT	0.22MF	20%	50V	
C717	1-124-902-00	ELECT	0.47MF	20%	50V	
C718	1-124-791-11	ELECT	1MF	20%	50V	
C719	1-161-055-00	CERAMIC	0.022MF	10%	50V	
C801	1-126-307-11	ELECT	6800MF	20%	50V	
C802	1-126-307-11	ELECT	6800MF	20%	50V	
C803	1-106-367-00	(AV320R/RA)..MYLAR	0.01MF	5%	200V	
C804	1-106-367-00	(AV320R/RA)..MYLAR	0.01MF	5%	200V	
C805	1-124-557-11	(AV320R/RA)..ELECT	1000MF	20%	25V	
C810	1-124-791-11	ELECT	1MF	20%	50V	
C820	1-124-477-11	(AV220/A)..ELECT	47MF	20%	25V	
C901	1-161-744-00	CERAMIC	0.01MF		400V	
C903	1-162-286-31	(WG)..CERAMIC	220PF	10%	50V	
C905	1-161-055-00	(WG)..CERAMIC	0.022MF	10%	50V	
C906	1-162-288-31	(WG)..CERAMIC	330PF	10%	50V	
C907	1-161-055-00	(WG)..CERAMIC	0.022MF	10%	50V	
C908	1-161-055-00	(WG)..CERAMIC	0.022MF	10%	50V	
C953	1-162-286-31	(WG)..CERAMIC	220PF	10%	50V	
C954	1-162-286-31	(WG)..CERAMIC	220PF	10%	50V	
C955	1-161-055-00	(WG)..CERAMIC	0.022MF	10%	50V	
C956	1-162-288-31	(WG)..CERAMIC	330PF	10%	50V	
C957	1-161-055-00	(WG)..CERAMIC	0.022MF	10%	50V	
C958	1-161-055-00	(WG)..CERAMIC	0.022MF	10%	50V	
CC2	1-249-366-11	CARBON MELF	0	5%	1/5W	
CC3	1-249-366-11	CARBON MELF	0	5%	1/5W	
CC11	1-249-366-11	(AEP,UK)..CARBON MELF	0	5%	1/5W	
CC12	1-249-366-11	(WG).....CARBON MELF	0	5%	1/5W	
CF1	1-567-389-11	FILTER, CERAMIC				
CF2	1-567-389-11	FILTER, CERAMIC				
CF3	1-567-389-11	(WG)..FILTER, CERAMIC				
CF21	1-577-075-11	OSCILLATOR, CERAMIC				
CFT21	1-404-853-11	TRANSFORMER, IF (CERAMIC FILTER)				
CN305	*1-564-777-11	(AV320R/RA).. PLUG, CONNECTOR (2.5MM) 2P				
CN803	*1-535-139-00	BASE POST 19MM (10MM PITCH) 2P				
CNJ1	*1-569-387-11	SOCKET, CONNECTOR (PC BOARD) 10P				
CNJ2	*1-569-380-11	SOCKET, CONNECTOR (PC BOARD) 3P				
CNJ4	*1-569-380-11	SOCKET, CONNECTOR (PC BOARD) 3P				
CNJ201	*1-569-411-11	SOCKET, CONNECTOR (PC BOARD) 16P				
CNJ301	*1-562-334-00	SOCKET, CONNECTOR 10P				
CNJ302	*1-562-334-00	SOCKET, CONNECTOR 10P				
CNJ303	*1-506-778-11	(AV320R/RA).. PLUG, CONNECTOR (2.5MM) 2P				
CNJ304	*1-506-680-11	PLUG, CONNECTOR (2.5MM) 3P				
CNJ305	*1-506-778-11	(AV320R/RA).. PLUG, CONNECTOR (2.5MM) 2P				
CNJ503	*1-506-707-31	PLUG, CONNECTOR (2.5MM) 3P				
CNJ601	*1-506-680-11	PLUG, CONNECTOR (2.5MM) 3P				
CNJ610	*1-569-509-11	CONNECTOR (SOCKET) 4P				
CNJ611	*1-562-573-11	SOCKET, CONNECTOR 8P				
CNJ701	*1-564-778-11	(AV320R/RA).. PLUG, CONNECTOR (2.5MM) 4P				
CNJ901	1-526-751-00	(AV320R:UK)..OUTLET, AC (AC OUTLET)				
CNJ901	1-526-794-11	(AV320RA:AV320R:WG) ..OUTLET, AC (AC OUTLET)				

Ref.No.	Part No.	Description
CNP301	1-565-419-11	PIN, CONNECTOR 10P
CNP302	1-565-419-11	PIN, CONNECTOR 10P
CNP401	*1-564-779-11	PLUG, CONNECTOR (2.5MM) 6P
CNP611	*1-569-508-11	PIN, CONNECTOR 8P
CNP650	*1-569-410-11	PIN, CONNECTOR (PC BOARD) 16P
CNP651	*1-569-388-11	PIN, CONNECTOR (PC BOARD) 3P
CNP652	*1-569-388-11	PIN, CONNECTOR (PC BOARD) 3P
CNP653	*1-569-395-11	PIN, CONNECTOR (PC BOARD) 10P
CNP654	*1-506-529-11	(AV320R/RA)..PIN CONNECTOR, B-B 4P
CNP655	*1-506-529-11	(AV320R/RA)..PIN CONNECTOR, B-B 4P
CNP656	*1-506-529-11	PIN CONNECTOR, B-B 4P
CNP657	*1-506-529-11	PIN CONNECTOR, B-B 4P
CNP658	*1-565-513-11	PIN, CONNECTOR 2P
CNP701	*1-535-116-00	TERMINAL
CNP701-A	*1-564-777-11	(AV320R/RA).. PLUG, CONNECTOR (2.5MM) 2P
CNP702	*1-535-116-00	TERMINAL
D301	8-719-912-20	DIODE 1SS120
D302	8-719-912-20	DIODE 1SS120
D303	8-719-912-20	DIODE 1SS120
D304	8-719-912-20	DIODE 1SS120
D305	8-719-912-20	DIODE 1SS120
D306	8-719-912-20	DIODE 1SS120
D307	8-719-912-20	DIODE 1SS120
D308	8-719-912-20	DIODE 1SS120
D309	8-719-912-20	DIODE 1SS120
D311	8-719-912-20	DIODE 1SS120
D312	8-719-912-20	DIODE 1SS120
D313	8-719-914-11	DIODE HZ4ALL
D314	8-719-912-20	DIODE 1SS120
D315	8-719-912-20	DIODE 1SS120
D316	8-719-301-38	(AV320R/RA)..DIODE SEL2210S-C (STANDBY)
D317	8-719-301-52	(AV320R/RA)..DIODE SEL2810A-C (MUTING)
D318	8-719-301-52	DIODE SEL2810A-C (SURROUND)
D319	8-719-301-52	DIODE SEL2810A-C (DBFB)
D320	8-719-912-20	DIODE 1SS120
D322	8-719-912-20	DIODE 1SS120
D323	8-719-912-20	DIODE 1SS120
D324	8-719-912-20	DIODE 1SS120
D326	8-719-912-20	DIODE 1SS120
D327	8-719-912-20	DIODE 1SS120
D328	8-719-303-00	(AV320R/RA)..DIODE SEL2510C (VOLUME)
D401	8-719-912-20	DIODE 1SS120
D402	8-719-912-20	DIODE 1SS120
D501	8-719-912-20	DIODE 1SS120
D502	8-719-912-20	DIODE 1SS120
D601	8-719-912-20	DIODE 1SS120
D602	8-719-912-20	DIODE 1SS120
D603	8-719-912-20	DIODE 1SS120
D604	8-719-912-20	DIODE 1SS120
D605	8-719-912-20	DIODE 1SS120
D607	8-719-912-20	DIODE 1SS120
D651	8-719-912-20	DIODE 1SS120
D702	8-719-010-86	DIODE RD13EL2
D703	8-719-010-29	DIODE UZ-4.3BSB
D704	8-719-011-07	DIODE UZ-27BSB
D705	8-719-010-82	DIODE UZ-15BSB
D706	8-719-010-47	DIODE UZ-6.2BSC
D707	8-719-933-41	DIODE HZS6C3L
D708	8-719-914-11	DIODE HZ4ALL
D709	8-719-912-20	DIODE 1SS120
D710	8-719-912-20	DIODE 1SS120
D711	8-719-912-20	DIODE 1SS120

Note: The components identified by mark  or dotted line with mark  are critical for safety. Replace only with part number specified.



Ref.No.	Part No.	Description
D801	8-719-312-09	DIODE RBA-402
D802	8-719-511-40	(AV320R/RA)...DIODE S1VB40
D803	8-719-912-20	(AV320R/RA)...DIODE ISS120
D813	8-719-000-06	DIODE MC921
F901	△ 1-532-973-11	(AV320R/RA)...FUSE (1.6A)
F902	△ 1-532-967-11	(AV220/A)...FUSE (1.25A)
F902	△ 1-532-973-11	(AV320R/RA)...FUSE (1.6A)
F903	△ 1-532-973-11	(AV320R/RA)...FUSE (1.6A)
FE1	1-463-857-11	(WG).....FRONT END, FM
FE1	1-463-862-21	(AEP,UK)...FRONT END, FM
FE61	1-236-461-11	ENCAPSULATED COMPONENT
FL301	1-519-509-11	INDICATOR TUBE, FLUORESCENT
IC21	8-759-821-45	IC LA1851N
IC81	8-759-820-91	IC LC7218
IC301	8-759-149-47	IC UPD75206G-557-1B
IC302	8-749-920-59	(AV320R/RA)...IC AIQH3020S
IC303	8-759-800-95	IC LB1493
IC304	8-759-820-62	(AV320R/RA)...IC LB1639
IC401	8-759-112-93	IC UPC4570HA-1
IC402	8-759-805-14	IC LC7822
IC501	8-759-112-93	IC UPC4570HA-1
IC601	8-749-900-34	(AV320R/RA)...IC STK4182MK2
IC601	8-749-941-52	(AV220/A)...IC STK415211
J501	1-565-320-11	JACK, PIN 6P (PHONE/CD/TAPE)
J502	1-565-320-11	JACK, PIN 6P (VIDEO/TAPE)
J601	1-507-863-51	JACK, LARGE TYPE (HEADPHONES)
L1	1-410-521-11	MICRO INDUCTOR 100UH
L2	1-410-521-11	(WG)...MICRO INDUCTOR 100UH
L21	1-410-171-11	MICRO INDUCTOR 1MMH
L301	1-410-521-11	INDUCTOR 100UH
L601	*1-420-872-00	COIL, AIR CORE
L651	*1-420-872-08	COIL, AIR CORE
LPF21	1-235-164-00	FILTER, LOW PASS
LPF22	1-235-164-00	FILTER, LOW PASS
Q1	8-729-230-99	TRANSISTOR 2SC26690Y
Q2	8-729-230-99	TRANSISTOR 2SC26690Y
Q3	8-729-230-99	(WG)...TRANSISTOR 2SC26690Y
Q4	8-729-230-99	(WG)...TRANSISTOR 2SC26690Y
Q21	8-729-119-78	TRANSISTOR 2SC2785-HFE
Q22	8-729-119-78	TRANSISTOR 2SC2785-HFE
Q23	8-729-900-61	TRANSISTOR DTA114ES
Q24	8-729-900-80	TRANSISTOR DTC114ES
Q81	8-729-900-61	TRANSISTOR DTA114ES
Q82	8-729-900-80	TRANSISTOR DTC114ES
Q83	8-729-202-67	TRANSISTOR 2SK246GR3
Q84	8-729-230-93	TRANSISTOR 2SC3113-AB
Q301	8-729-900-36	(AV320R/RA)...TRANSISTOR DTC124ES
Q302	8-729-900-36	(AV320R/RA)...TRANSISTOR DTC124ES
Q303	8-729-900-36	TRANSISTOR DTC124ES
Q304	8-729-900-36	TRANSISTOR DTC124ES
Q401	8-729-107-84	TRANSISTOR 2SC3623A-LK
Q402	8-729-620-05	TRANSISTOR 2SC2603-EF
Q403	8-729-119-76	TRANSISTOR 2SA1175-HFE
Q451	8-729-107-84	TRANSISTOR 2SC3623A-LK
Q452	8-729-620-05	TRANSISTOR 2SC2603-EF
Q501	8-729-202-67	TRANSISTOR 2SK246-GR3
Q502	8-729-620-05	TRANSISTOR 2SC2603-EF

Ref.No.	Part No.	Description
Q503	8-729-141-30	(AV320R/RA)...TRANSISTOR 2SC3623A-LK
Q504	8-729-202-67	TRANSISTOR 2SK246-GR3
Q505	8-729-900-36	TRANSISTOR DTC124ES
Q506	8-729-900-63	TRANSISTOR DTA124ES
Q551	8-729-202-67	TRANSISTOR 2SK246-GR3
Q552	8-729-620-05	TRANSISTOR 2SC2603-EF
Q553	8-729-141-30	(AV320R/RA)...TRANSISTOR 2SC3623A-LK
Q601	8-729-108-14	TRANSISTOR 2SA988-F
Q602	8-729-620-05	TRANSISTOR 2SC2603-EF
Q603	8-729-620-05	TRANSISTOR 2SC2603-EF
Q604	8-729-620-05	TRANSISTOR 2SC2603-EF
Q605	8-729-620-05	TRANSISTOR 2SC2603-EF
Q651	8-729-108-14	TRANSISTOR 2SA988-F
Q701	8-729-107-25	TRANSISTOR 2SD1585-L
Q702	8-729-113-34	TRANSISTOR 2SB733-5
Q703	8-729-180-92	TRANSISTOR 2SD809-K
Q704	8-729-620-05	TRANSISTOR 2SC2603-EF
Q705	8-729-115-22	TRANSISTOR BN1A3Q
Q706	8-729-119-76	TRANSISTOR 2SA1175-HFE
Q707	8-729-620-05	TRANSISTOR 2SC2603-EF
Q708	8-729-900-36	TRANSISTOR DTC124ES
Q709	8-729-620-05	(AV320R/RA)...TRANSISTOR 2SC2603-EF
Q801	8-729-620-05	(AV320R/RA)...TRANSISTOR 2SC2603-EF
R1	1-249-397-11	(WG)...CARBON (SMALL) 22
R1	1-249-401-11	(AEP,UK)...CARBON (SMALL) 47
R3	1-249-329-11	CARBON MELF 330 5% 1/8W
R4	1-249-329-11	CARBON MELF 330 5% 1/8W
R5	1-249-329-11	CARBON MELF 330 5% 1/8W
R6	1-249-350-11	CARBON MELF 18K 5% 1/8W
R7	1-249-329-11	CARBON MELF 330 5% 1/8W
R8	1-249-332-11	CARBON MELF 560 5% 1/8W
R9	1-249-352-11	CARBON MELF 27K 5% 1/8W
R10	1-249-329-11	(WG)...CARBON MELF 330 5% 1/8W
R11	1-249-350-11	(WG)...CARBON MELF 18K 5% 1/8W
R12	1-249-329-11	(WG)...CARBON MELF 330 5% 1/8W
R13	1-249-334-11	(WG)...CARBON MELF 820 5% 1/8W
R14	1-249-352-11	(WG)...CARBON MELF 27K 5% 1/8W
R15	1-249-347-11	(WG)...CARBON MELF 10K 5% 1/8W
R16	1-249-343-11	(WG)...CARBON MELF 4.7K 5% 1/8W
R21	1-249-404-00	CARBON (SMALL) 82
R22	1-249-433-11	CARBON (SMALL) 22K
R23	1-249-335-11	CARBON MELF 1K 5% 1/8W
R24	1-249-353-11	CARBON MELF 33K 5% 1/8W
R25	1-249-346-11	CARBON MELF 8.2K 5% 1/8W
R26	1-249-340-11	(WG)...CARBON MELF 2.7K 5% 1/8W
R27	1-249-432-11	CARBON (SMALL) 18K
R28	1-249-423-11	CARBON (SMALL) 3.3K
R29	1-249-347-11	CARBON MELF 10K 5% 1/8W
R31	1-249-331-11	CARBON MELF 470 5% 1/8W
R32	1-249-347-11	CARBON MELF 10K 5% 1/8W
R33	1-249-347-11	CARBON MELF 10K 5% 1/8W
R35	1-249-355-11	CARBON MELF 47K 5% 1/8W
R36	1-249-429-11	CARBON (SMALL) 10K
R37	1-249-359-11	CARBON MELF 100K 5% 1/8W
R38	1-249-363-11	CARBON MELF 220K 5% 1/8W

Note: The components identified by mark △ or dotted line with mark △ are critical for safety. Replace only with part number specified.

Ref.No.	Part No.	Description				
R39	1-249-339-11	CARBON MELF	2.2K	5%	1/8W	
R40	1-249-338-11	CARBON MELF	1.8K	5%	1/8W	
R41	1-249-344-11	CARBON MELF	5.6K	5%	1/8W	
R42	1-249-359-11	CARBON MELF	100K	5%	1/8W	
R43	1-249-363-11	CARBON MELF	220K	5%	1/8W	
R44	1-249-339-11	CARBON MELF	2.2K	5%	1/8W	
R45	1-249-338-11	CARBON MELF	1.8K	5%	1/8W	
R46	1-249-344-11	CARBON MELF	5.6K	5%	1/8W	
R47	1-249-409-11	CARBON (SMALL) 220				
R48	1-249-359-11	CARBON MELF	100K	5%	1/8W	
R49	1-249-359-11	CARBON MELF	100K	5%	1/8W	
R61	1-249-359-11	CARBON MELF	100K	5%	1/8W	
R62	1-249-355-11	CARBON MELF	47K	5%	1/8W	
R63	1-249-315-11	CARBON MELF	22	5%	1/8W	
R81	1-249-335-11	CARBON MELF	1K	5%	1/8W	
R82	1-249-335-11	CARBON MELF	1K	5%	1/8W	
R83	1-249-335-11	CARBON MELF	1K	5%	1/8W	
R84	1-249-335-11	CARBON MELF	1K	5%	1/8W	
R85	1-249-347-11	CARBON MELF	10K	5%	1/8W	
R86	1-249-355-11	CARBON MELF	1K	5%	1/8W	
R87	1-249-347-11	CARBON MELF	10K	5%	1/8W	
R88	1-249-343-11	CARBON MELF	4.7K	5%	1/8W	
R89	1-249-335-11	CARBON MELF	1K	5%	1/8W	
R90	1-249-347-11	CARBON MELF	10K	5%	1/8W	
R91	1-249-335-11	CARBON MELF	1K	5%	1/8W	
R92	1-249-401-11	CARBON (SMALL) 47				
R101	1-249-341-11	CARBON MELF	3.3K	5%	1/8W	
R102	1-249-332-11	CARBON MELF	560	5%	1/8W	
R103	1-249-335-11	CARBON MELF	1K	5%	1/8W	
R104	1-249-328-11	CARBON MELF	270	5%	1/8W	
R105	1-249-343-11	CARBON MELF	4.7K	5%	1/8W	
R106	1-249-339-11	CARBON MELF	2.2K	5%	1/8W	
R107	1-249-343-11	CARBON MELF	4.7K	5%	1/8W	
R108	1-249-323-11	CARBON MELF	100	5%	1/8W	
R109	1-249-343-11	CARBON MELF	4.7K	5%	1/8W	
R110	1-249-405-11	CARBON (SMALL) 100				
R301	1-249-411-11	CARBON	330	5%	1/4W	
R302	1-249-411-11	CARBON	330	5%	1/4W	
R303	1-249-411-11	CARBON	330	5%	1/4W	
R304	1-249-411-11	CARBON	330	5%	1/4W	
R305	1-249-429-11	CARBON	10K	5%	1/4W	
R306	1-249-429-11	CARBON	10K	5%	1/4W	
R307	1-249-429-11	CARBON	10K	5%	1/4W	
R308	1-249-429-11	CARBON	10K	5%	1/4W	
R311	1-249-429-11	CARBON	10K	5%	1/4W	
R312	1-249-431-11	CARBON	15K	5%	1/4W	
R313	1-249-417-11	CARBON	1K	5%	1/4W	
R314	1-249-441-11	CARBON	100K	5%	1/4W	
R315	1-249-437-11	CARBON	47K	5%	1/4W	
R316	1-249-441-11	CARBON	100K	5%	1/4W	
R321	1-249-410-11	(AV320R/RA)...CARBON	270	5%	1/4W	
R322	1-249-410-11	CARBON	270	5%	1/4W	
R323	1-249-410-11	CARBON	270	5%	1/4W	
R324	1-249-410-11	CARBON	270	5%	1/4W	
R325	1-249-441-11	CARBON	100K	5%	1/4W	
R331	1-249-437-11	CARBON	47K	5%	1/4W	
R332	1-249-437-11	CARBON	47K	5%	1/4W	

Ref.No.	Part No.	Description				
R333	1-249-437-11	CARBON	47K	5%	1/4W	
R334	1-249-437-11	CARBON	47K	5%	1/4W	
R335	1-249-437-11	CARBON	47K	5%	1/4W	
R336	1-249-431-11	CARBON	15K	5%	1/4W	
R337	1-249-437-11	CARBON	47K	5%	1/4W	
R338	1-249-437-11	CARBON	47K	5%	1/4W	
R339	1-249-393-11	(AV320R/RA)...CARBON	10	5%	1/4W	
R401	1-249-411-11	CARBON	330	5%	1/4W	
R402	1-249-417-11	CARBON	1K	5%	1/4W	
R403	1-249-417-11	CARBON	1K	5%	1/4W	
R404	1-249-425-11	CARBON	4.7K	5%	1/4W	
R405	1-249-417-11	CARBON	1K	5%	1/4W	
R406	1-249-425-11	CARBON	4.7K	5%	1/4W	
R407	1-247-897-11	CARBON	560K	5%	1/4W	
R408	1-247-897-11	CARBON	560K	5%	1/4W	
R409	1-249-437-11	CARBON	47K	5%	1/4W	
R410	1-247-897-11	CARBON	560K	5%	1/4W	
R411	1-249-416-11	CARBON	820	5%	1/4W	
R412	1-247-897-11	CARBON	560K	5%	1/4W	
R413	1-249-437-11	CARBON	47K	5%	1/4W	
R414	1-247-897-11	CARBON	560K	5%	1/4W	
R415	1-249-417-11	CARBON	1K	5%	1/4W	
R416	1-249-411-11	CARBON	330	5%	1/4W	
R417	1-249-411-11	CARBON	330	5%	1/4W	
R418	1-249-425-11	CARBON	4.7K	5%	1/4W	
R419	1-249-425-11	CARBON	4.7K	5%	1/4W	
R420	1-249-437-11	CARBON	47K	5%	1/4W	
R421	1-247-901-11	CARBON	820K	5%	1/4W	
R422	1-249-425-11	CARBON	4.7K	5%	1/4W	
R423	1-249-441-11	CARBON	100K	5%	1/4W	
R424	1-249-421-11	CARBON	2.2K	5%	1/4W	
R425	1-249-441-11	CARBON	100K	5%	1/4W	
R426	1-249-405-11	CARBON	100	5%	1/4W	
R428	1-249-417-11	(WG)...CARBON	1K	5%	1/4W	
R451	1-249-411-11	CARBON	330	5%	1/4W	
R452	1-249-417-11	CARBON	1K	5%	1/4W	
R453	1-249-417-11	CARBON	1K	5%	1/4W	
R454	1-249-425-11	CARBON	4.7K	5%	1/4W	
R455	1-249-417-11	CARBON	1K	5%	1/4W	
R456	1-249-425-11	CARBON	4.7K	5%	1/4W	
R457	1-247-897-11	CARBON	560K	5%	1/4W	
R458	1-247-897-11	CARBON	560K	5%	1/4W	
R459	1-249-437-11	CARBON	47K	5%	1/4W	
R460	1-247-897-11	CARBON	560K	5%	1/4W	
R461	1-249-416-11	CARBON	820	5%	1/4W	
R462	1-247-897-11	CARBON	560K	5%	1/4W	
R463	1-249-437-11	CARBON	47K	5%	1/4W	
R464	1-247-897-11	CARBON	560K	5%	1/4W	
R465	1-249-417-11	CARBON	1K	5%	1/4W	
R469	1-249-425-11	CARBON	4.7K	5%	1/4W	
R470	1-249-437-11	CARBON	47K	5%	1/4W	
R471	1-247-901-11	CARBON	320K	5%	1/4W	
R472	1-249-425-11	CARBON	4.7K	5%	1/4W	
R478	1-249-417-11	(WG)...CARBON	1K	5%	1/4W	
R501	1-249-429-11	CARBON	10K	5%	1/4W	
R502	1-249-421-11	CARBON	2.2K	5%	1/4W	
R503	1-249-441-11	CARBON	100K	5%	1/4W	

Ref.No.	Part No.	Description			
R504	1-249-427-11	CARBON	6.8K	5%	1/4W
R505	1-249-438-11	CARBON	56K	5%	1/4W
R506	1-249-441-11	CARBON	100K	5%	1/4W
R507	1-247-883-00	CARBON	150K	5%	1/4W
R508	1-249-417-11	CARBON	1K	5%	1/4W
R509	1-249-412-11	CARBON	390	5%	1/4W
R510	1-249-427-11	CARBON	6.8K	5%	1/4W
R511	1-249-417-11	CARBON	1K	5%	1/4W
R512	1-249-430-11	CARBON	12K	5%	1/4W
R513	1-249-404-00	(AV320R/RA)...CARBON	82	5%	1/4W
R514	1-249-429-11	(AV320R/RA)...CARBON	10K	5%	1/4W
R515	1-249-434-11	CARBON	27K	5%	1/4W
R516	1-249-434-11	CARBON	27K	5%	1/4W
R517	1-249-441-11	CARBON	100K	5%	1/4W
R518	1-249-441-11	CARBON	100K	5%	1/4W
R519	1-249-441-11	CARBON	100K	5%	1/4W
R520	1-247-903-00	CARBON	1M	5%	1/4W
R521	1-249-428-11	CARBON	8.2K	5%	1/4W
R522	1-247-903-00	CARBON	1M	5%	1/4W
R523	1-249-441-11	(AV320R/RA)...CARBON	100K	5%	1/4W
R524	1-249-426-11	(AV320R/RA)...CARBON	5.6K	5%	1/4W
R551	1-249-429-11	CARBON	10K	5%	1/4W
R552	1-249-421-11	CARBON	2.2K	5%	1/4W
R553	1-249-441-11	CARBON	100K	5%	1/4W
R554	1-249-427-11	CARBON	6.8K	5%	1/4W
R555	1-249-438-11	CARBON	56K	5%	1/4W
R556	1-249-441-11	CARBON	100K	5%	1/4W
R557	1-247-883-00	CARBON	150K	5%	1/4W
R558	1-249-417-11	CARBON	1K	5%	1/4W
R559	1-249-412-11	CARBON	390	5%	1/4W
R560	1-249-427-11	CARBON	6.8K	5%	1/4W
R561	1-249-417-11	CARBON	1K	5%	1/4W
R562	1-249-430-11	CARBON	12K	5%	1/4W
R563	1-249-404-00	(AV320R/RA)...CARBON	82	5%	1/4W
R564	1-249-429-11	(AV320R/RA)...CARBON	10K	5%	1/4W
R601	1-249-417-11	CARBON	1K	5%	1/4W
R602	1-249-438-11	CARBON	56K	5%	1/4W
R603	1-249-411-11	CARBON	330	5%	1/4W
R604	1-249-421-11	(AV220/A)...CARBON	2.2K	5%	1/4W
R604	1-249-423-11	(AV320R/RA)...CARBON	3.3K	5%	1/4W
R605	1-249-438-11	CARBON	56K	5%	1/4W
R606	1-247-756-11	(AV220/A)...CARBON	2.2K	5%	1/2W
R606	1-247-758-11	(AV320R/RA)...CARBON	3.3K	5%	1/2W
R607	△1-217-151-00	RES, METAL PLATE 0.22			
R608	1-249-417-11	CARBON	1K	5%	1/4W
R612	△1-249-405-11	CARBON	100	5%	1/4W F
R615	△1-249-405-11	CARBON	100	5%	1/4W F
R621	1-249-427-11	CARBON	6.8K	5%	1/4W
R622	1-249-435-11	CARBON	33K	5%	1/4W
R623	1-249-433-11	CARBON	22K	5%	1/4W
R624	△1-247-727-11	CARBON	10	5%	1/2W F
R625	1-247-768-00	CARBON	2.4	5%	1/4W
R626	1-249-441-11	CARBON	100K	5%	1/4W
R627	1-249-435-11	CARBON	33K	5%	1/4W
R628	1-249-427-11	CARBON	6.8K	5%	1/4W
R629	△1-249-399-11	CARBON	33	5%	1/4W F

Ref.No.	Part No.	Description			
R630	1-249-417-11	CARBON	1K	5%	1/4W
R631	1-249-429-11	CARBON	10K	5%	1/4W
R632	1-249-441-11	CARBON	100K	5%	1/4W
R633	1-249-429-11	CARBON	10K	5%	1/4W
R634	1-249-423-11	CARBON	3.3K	5%	1/4W
R635	1-249-441-11	CARBON	100K	5%	1/4W
R636	1-247-903-00	CARBON	1M	5%	1/4W
R637	△1-215-866-11	(AV220/A)...METAL OXIDE	330	5%	1W F
R637	△1-216-432-00	(AV320R/RA)...METAL OXIDE	820	5%	1W F
R638	△1-215-889-00	(AV220/A)...METAL OXIDE	330	5%	2W F
R638	△1-216-454-11	(AV320R/RA)...METAL OXIDE	390	5%	2W F
R639	1-247-768-00	CARBON	2.4	5%	1/4W
R640	1-249-393-11	(WG)...CARBON	10	5%	1/4W
R641	1-249-393-11	(WG)...CARBON	10	5%	1/4W
R651	1-249-417-11	CARBON	1K	5%	1/4W
R652	1-249-438-11	CARBON	56K	5%	1/4W
R653	1-249-411-11	CARBON	330	5%	1/4W
R654	1-249-421-11	(AV220/A)...CARBON	2.2K	5%	1/4W
R654	1-249-423-11	(AV320R/RA)...CARBON	3.3K	5%	1/4W
R655	1-249-438-11	CARBON	56K	5%	1/4W
R656	1-247-756-11	(AV220/A)...CARBON	2.2K	5%	1/2W
R656	1-247-758-11	(AV320R/RA)...CARBON	3.3K	5%	1/2W
R657	1-217-151-00	RES, METAL PLATE 0.22			
R658-A	1-249-417-11	CARBON	1K	5%	1/4W
R658-B	1-215-889-00	(AV220/A)...METAL OXIDE	330	5%	2W F
R658-B	1-216-454-11	(AV320R/RA)...METAL OXIDE	390	5%	2W F
R671	1-249-427-11	CARBON	6.8K	5%	1/4W
R672	1-249-435-11	CARBON	33K	5%	1/4W
R673	1-249-433-11	CARBON	22K	5%	1/4W
R674	△1-247-727-11	CARBON	10	5%	1/2W F
R675	1-247-768-00	CARBON	2.4	5%	1/4W
R676	1-249-441-11	CARBON	100K	5%	1/4W
R689	1-247-768-00	CARBON	2.4	5%	1/4W
R690	1-249-393-11	(WG)...CARBON	10K	5%	1/4W
R691	1-249-393-11	(WG)...CARBON	10K	5%	1/4W
R702	1-249-422-11	CARBON	2.7K	5%	1/4W
R703	△1-216-448-11	METAL OXIDE	39	5%	2W F
R705	1-249-423-11	CARBON	3.3K	5%	1/4W
R706	△1-249-405-11	CARBON	100	5%	1/4W F
R707	1-249-410-11	CARBON	270	5%	1/
R708	△1				
R709	1-249-423-11	CARBON	3.3K	5%	1/4W
R710	1-249-429-11	(AV220/A)...CARBON	10K	5%	1/4W
R710	1-249-433-11	(AV320R/RA)...CARBON	22K	5%	1/4W
R711	1-249-429-11	CARBON	10K	5%	1/4W
R712	1-249-429-11	CARBON	10K	5%	1/4W
R713	1-249-426-11	CARBON	5.6K	5%	1/4W
R714	1-249-417-11	CARBON	1K	5%	1/4W
R715	1-249-426-11	CARBON	5.6K	5%	1/4W
R716	1-249-417-11	(AV320R/RA)...CARBON	1K	5%	1/4W

Note: The components identified by mark △ or dotted line with mark △ are critical for safety. Replace only with part number specified.

Ref.No.	Part No.	Description	Ref.No.	Part No.	Description
R717	1-249-429-11	(AV320R/RA)...CARBON 10K 5% 1/4W	S317	1-554-303-21	SWITCH, KEY BOARD (9)
R718	$\Delta$ 1-249-401-11	CARBON 47 5% 1/4W F	S318	1-554-303-21	SWITCH, KEY BOARD (MEMORY)
R719	1-249-425-11	CARBON 4.7K 5% 1/4W	S319	1-554-303-21	SWITCH, KEY BOARD (4)
R720	1-249-437-11	CARBON 47K 5% 1/4W	S320	1-554-303-21	SWITCH, KEY BOARD (5)
R721	1-249-413-11	CARBON 470 5% 1/4W	S321	1-554-303-21	SWITCH, KEY BOARD (6)
R722	1-249-437-11	CARBON 47K 5% 1/4W	S322	1-554-303-21	SWITCH, KEY BOARD (0)
R723	1-249-437-11	CARBON 47K 5% 1/4W	S323	1-554-303-21	SWITCH, KEY BOARD (1)
R724	1-249-437-11	CARBON 47K 5% 1/4W	S324	1-554-303-21	SWITCH, KEY BOARD (2)
R725	1-249-437-11	CARBON 47K 5% 1/4W	S325	1-554-303-21	SWITCH, KEY BOARD (3)
R726	1-249-410-11	(AV320R/RA)...CARBON 270 5% 1/4W	S326	1-554-303-21	SWITCH, KEY BOARD (SHIFT)
R726	1-249-430-11	(AV220/A)...CARBON 12K 5% 1/4W	S327	1-554-303-21	SWITCH, KEY BOARD (DBFB)
R727	1-249-437-11	(AV220/A)... CARBON 47K 5% 1/4W	S328	1-554-303-21	(AV320R/RA)...SWITCH, KEY BOARD (MUTING -20dB)
R801	$\Delta$ 1-249-389-11	CARBON 4.7 5% 1/4W F	S329	1-554-303-21	SWITCH, KEY BOARD (SURROUND)
R802	1-249-437-11	(AV320R/RA)...CARBON 47K 5% 1/4W	S330	1-554-303-21	(AV320R/RA)..SWITCH, KEY BOARD (SYSTEM POWER)(POWER)
R803	1-249-396-11	(AV320R/RA)...CARBON 18 5% 1/4W	S601	1-571-485-11	SWITCH, PUSH (2 KEY)(SPEAKER A)
R804	$\Delta$ 1-247-739-11	(AV320R/RA)...CARBON 100 5% 1/2W F	S602	1-571-485-11	SWITCH, PUSH (2 KEY)(SPEAKER B)
R804	$\Delta$ 1-249-482-11	(AV220/A)...CARBON 4.7 5% 1/2W F	S901	$\Delta$ 1-554-685-11	(AV220/A)...SWITCH, PUSH (AC POWER)(1 KEY)
R805	1-249-425-11	(AV320R/RA)...CARBON 4.7K 5% 1/4W	S902	1-570-046-21	(AEP)..SWITCH, VOLTAGE CHANGE (SPEAKER IMPEDANCE SELECTOR)
R901	1-249-396-11	(WG)...CARBON 18 5% 1/4W	T21	1-404-807-11	TRANSFORMER, DISCRIMINATOR
R951	1-249-396-11	(WG)...CARBON 18 5% 1/4W	T23	1-236-465-11	(WG)...ENCAPSULATED COMPONENT
RB301	1-233-081-11	COMPOSITION CIRCUIT BLOCK	T901	$\Delta$ 1-449-758-11	(AV320R:UK)...TRANSFORMER, POWER
RB302	1-232-955-11	COMPOSITION CIRCUIT BLOCK	T901	$\Delta$ 1-449-760-11	(AV320R:WG)...TRANSFORMER, POWER
RB303	1-232-998-11	COMPOSITION CIRCUIT BLOCK	T901	$\Delta$ 1-449-761-11	(AV220)...TRANSFORMER, POWER
RV21	1-238-013-11	RES. ADJ. CARBON 2.2K (FM STEREO SPARATION)	T901	$\Delta$ 1-450-140-11	(AV320RA)...TRANSFORMER, POWER
RV23	1-238-021-11	RES. ADJ. CARBON 220K (AM METER)	T901	$\Delta$ 1-450-141-11	(AV220A)...TRANSFORMER, POWER
RV24	1-236-019-11	(WG)..... RES. ADJ. CARBON 47K (FM STEREO OPERATION LEVEL)	T902	$\Delta$ 1-448-523-11	(AV320R/RA)...TRANSFORMER, POWER
RV24	1-238-017-11	(AEP,UK)... RES. ADJ. CARBON 22K (FM STEREO OPERATION LEVEL)	TM1	*1-537-138-31	(AEP,UK)...TERMINAL BOARD (ANT)
RV501	1-238-942-11	RES. VAR. CARBON 100K (BALANCE)	TM601	$\Delta$ 1-536-706-00	TERMINAL BOARD (SPEAKER A/B)
RV502	1-238-074-11	(AV220/A)...RES. VAR. CARBON 100K/100K (VOLUME)	TP1	*1-560-060-00	PIN, CONNECTOR 2P
RV502	1-238-943-11	(AV320R/RA)...RES. VAR. CARBON 100K/100K (VOLUME)	VZR901	$\Delta$ 1-807-180-11	(AV320R/RA)..VARISTOR SNR-14A300K
RV503	1-238-941-11	RES. VAR. CARBON 50K/50K (TONE BASS)	X301	1-567-170-00	OSCILLATOR, CERAMIC (4.194MHz)
RV504	1-238-941-11	RES. VAR. CARBON 50K/50K (TONE TREBLE)	XT81	1-577-126-11	VIBRATOR, CRYSTAL
RY601	1-515-533-11	RELAY	<b>ACCESSORY &amp; PACKING MATERIAL</b>		
RY901	1-515-720-11	(AV320R/RA)...RELAY	1-465-420-11	(AV320R:UK)...REMOTE COMMANDER (RM-U203)	
S301	1-554-303-21	SWITCH, KEY BOARD (TUNING DIRECT)	1-465-420-11	(AV320RA, AV320R:WG)... REMOTE COMMANDER (RM-S103)	
S302	1-554-303-21	SWITCH, KEY BOARD (PRESET -)	1-501-369-11	(AEP,UK)...ANTENNA	
S303	1-554-303-21	SWITCH, KEY BOARD (TUNING -)	1-501-374-11	ANTENNA, LOOP	
S304	1-554-303-21	SWITCH, KEY BOARD (BAND FM)	2-181-754-01	(AV320RA/AV320R)...COVER, BATTERY	
S305	1-554-303-21	SWITCH, KEY BOARD (FM MODE)	3-751-607-11	(AEP)...MANUAL, INSTRUCTION (ENGLISH, F, E)	
S306	1-554-303-21	SWITCH, KEY BOARD (PRESET +)	3-751-607-41	(UK)...MANUAL, INSTRUCTION (ENGLISH)	
S307	1-554-303-21	SWITCH, KEY BOARD (TUNING +)	3-751-607-51	(AEP)...MANUAL, INSTRUCTION (D, NL, S)	
S308	1-554-303-21	SWITCH, KEY BOARD (BAND AM)	3-751-607-61	(WG)...MANUAL, INSTRUCTION (D)	
S310	1-554-303-21	SWITCH, KEY BOARD (TAPE)	3-751-651-41	INSTRUCTION	
S311	1-554-303-21	SWITCH, KEY BOARD (VIDEO)	4-925-079-01	(AV320R:UK)...COVER(6), BATTERY	
S312	1-554-303-21	SWITCH, KEY BOARD (PHONO)	*4-931-010-01	CUSHION (BOTTOM)	
S313	1-554-303-21	SWITCH, KEY BOARD (TUNING)	*4-931-011-01	CUSHION (TOP)	
S314	1-554-303-21	SWITCH, KEY BOARD (CD)	*4-938-141-01	(AV320R/RA)...INDIVIDUAL CARTON	
S315	1-554-303-21	SWITCH, KEY BOARD (7)	*4-931-097-01	(AV220/A)...INDIVIDUAL CARTON	
S316	1-554-303-21	SWITCH, KEY BOARD (8)	F : FRENCH	D : GERMAN	
			E : SPANISH	NL : DUTCH	
				S : SWEDISH	