

STR-D1090/D2090

SERVICE MANUAL

US Model
Canadian Model
E Model
STR-D1090

US Model
Canadian Model
STR-D2090



Photo : STR-D2090

SPECIFICATIONS

Audio Power Specifications

POWER OUTPUT AND TOTAL HARMONIC DISTORTION

With 8-ohm load, both channels driven, from 20 - 20,000 Hz, rated 120 watts per channel minimum RMS power, with no more than 0.04 % total harmonic distortion from 250 milliwatts to rated output.

	Surround mode	Stereo mode
FRONT	75 W + 75 W	120 W + 120 W
CENTER*	75 W	—
REAR	30 W + 30 W	—

* (only in the DOLBY, THEATER and LIVE modes)

Other Specifications

Dynamic power output (in the stereo mode)	8 ohms, at 1 kHz IHF	185 + 185 watts
	4 ohms, at 1 kHz IHF	235 + 235 watts
Frequency response	PHONO	RIAA equalization curve ± 0.5 dB
	CD, DAT, TAPE 1,2 VIDEO 1,2,3	10 Hz — 20 kHz ± 1 dB

Damping factor (8 ohms, at 1kHz)		50
Input sensitivity/ impedance	PHONO MM	4 mV, 50 kilohms
	DAT, CD, VIDEO 1,2,3 TAPE 1,2	250 mV 50 kilohms
S/N	PHONO MM	87 dB 79 dB** (A,2.5mV)
	DAT, CD VIDEO 1,2,3 TAPE 1,3	105 dB 85 dB** (A,150mV)
Output sensitivity/ impedance	DAT OUT, TAPE OUT 1,2 VIDEO 1	250 mV 10 kilohms
	SPEAKERS	Accepts speakers of 8-16 ohms
	HEADPHONES	Accepts headphones of high and low impedance
	SURROUND OUT REAR	2.5 V, 1kilohm
	SURROUND OUT CENTER	2.5 V, 1kilohm
	SURROUND OUT MONO	1 V, 1kilohm
	MUTING	-20dB
DBFB	+10 dBat 70Hz	

** '78IHF

— Continued next page —

FM STEREO/FM-AM RECEIVER
SONY®



Digital signal processor section

Modulation (A/D conversion)		High Density Linear Converter
Demonstration (D/A conversion)		High Density Linear Converter (Pulse D/A Converter)
Sampling frequency		48 kHz
Equalizer	Band	3-band, Bass/treble Mid
	Turnover frequency	Bass: 125 Hz — 1 kHz Treble: 1 kHz — 8 kHz
	Center frequency	Mid: 54 — 8 kHz
	Level	±10 dB, 1 dB step
	Slope (Q)	3-step selectable, Wide, Mid, Narrow
Surround	ROOM SIZE	16-step adjustable
	WALL	16-step adjustable
	SEAT POSITION F/R	16-step adjustable
	SEAT POSITION L/R	16-step adjustable
	EFFECT LEVEL	20-step adjustable
	REVERB TIME	16-step adjustable
	DELAY TIME**	15.0 ms-30.0 ms, 0.1 ms step
	REAR LEVEL	+10 — -50 dB, 1 dB step
	CENTER LEVEL***	+10 — -50 dB, 1 dB step
	INPUT BALANCE	Automatic

** (only in the DOLBY mode)

*** (only in the DOLBY, THEATER and LIVE modes)

FM tuner section

Frequency range		87.5 — 108.0 MHz
Antenna terminals		75 ohms, unbalanced
Sensitivity at 50 dB		18.3 dBf, 4.5 μV (mono) 38.3 dBf, 45 μV (stereo)
Usable sensitivity		11.2 dBf, 2 μV (IHF)
S/N	Mono	80 dB
	Stereo	74 dB
Harmonic distortion at 1 kHz	Mono	0.3 %
	Stereo	0.5 %
IM distortion	Mono	0.3 %
	Stereo	0.5 %
Separation		45 dB at 1 kHz
Frequency response		30 Hz — 15 kHz $^{+0}_{-2}$ dB
Selectivity		60 dB at 400 kHz
Capture ratio		1.2 dB
AM suppression ratio		54 dB
Image response ratio		70 dB

IF response ratio		70 dB
Spurious response ratio		80 dB
RF intermodulation at 800 kHz		60 dB
Auto tuning threshold	Low	30 dBf
	High	50 dBf

AM tuner section

Frequency range	530 — 1710 kHz (with 10 kHz interval) 531 — 1710 kHz (with 9 kHz interval)
Antenna	Loop antenna
Usable sensitivity	50 dB/m (at 1,000 kHz or 999 kHz)
S/N	54 dB (at 50 mV/m)
Harmonic distortion	0.5% (50 mV/m, 400 Hz)
Selectivity	35 dB (9 kHz), 40 dB (10 kHz)
Auto tuning threshold	55 dB/m

Video section

Inputs	VIDEO 1,2,3: 1 Vp-p 75 ohms
Outputs	VIDEO 1, MONITOR: 1 Vp-p 75 ohms

General

		STR-D2090	STR-D1090
System	Tuner section	PLL quartz-locked digital synthesizer system	
	Preamplifier section	Low-noise NF type equalizer	
	Power amplifier section	Pure-complimentary SEPP	
Power requirements		120 V AC, 60 Hz	
Power consumption		USA model: 260 watts Canada model: 320 VA	
AC outlets		Two switched, total 120 watts	
Dimensions (including projecting parts and controls)		Approx. 430 x 148 x 385 mm (17 x 5 ¹³ / ₁₆ x 15 ³ / ₁₆ inches)	
Weight		Approx. 13.6 kg (30 lb)	Approx. 13.2 kg (29 lb 1 oz)

Supplied accessories

- FM wire antenna (1)
- AM loop antenna (1)
- Remote commander
- RM-P321(STR-D2090) (1)
- RM-U221(STR-D1090) (1)
- Sony Batteries SUM-3(NS) (2)

Design and specifications are subject to change without notice.

SAFETY CHECK-OUT

After correcting the original service problem, perform the following safety check before releasing the set to the customer:

Check the antenna terminals, metal trim, "metallized" knobs, screws, and all other exposed metal parts for AC leakage. Check leakage as described below.

LEAKAGE TEST

The AC leakage from any exposed metal part to earth ground and from all exposed metal parts to any exposed metal part having a return to chassis, must not exceed 0.5 mA (500 microampers). Leakage current can be measured by any one of three methods.

1. A commercial leakage tester, such as the Simpson 229 or RCA WT-540A. Follow the manufacturers' instructions to use these instruments.
2. A battery-operated AC milliammeter. The Data Precision 245 digital multimeter is suitable for this job.
3. Measuring the voltage drop across a resistor by means of a VOM or battery-operated AC voltmeter. The "limit" indication is 0.75 V, so analog meters must have an accurate low-voltage scale. The Simpson 250 and Sanwa SH-63Trd are examples of a passive VOM that is suitable. Nearly all battery operated digital multimeters that have a 2 V AC range are suitable. (See Fig. A)

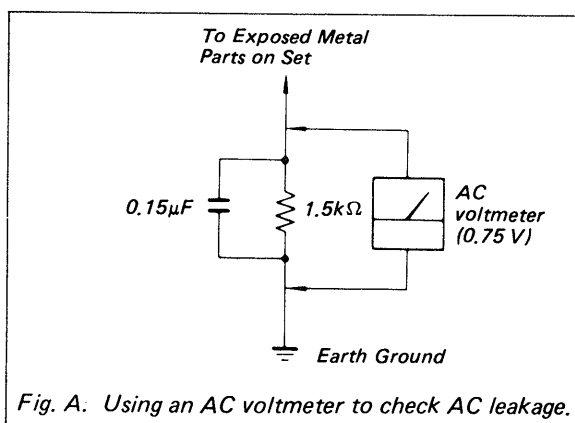



SAFETY-RELATED COMPONENT WARNING!!
COMPONENTS IDENTIFIED BY MARK  OR DOTTED LINE WITH MARK  ON THE SCHEMATIC DIAGRAMS AND IN THE PARTS LIST ARE CRITICAL TO SAFE OPERATION. REPLACE THESE COMPONENTS WITH SONY PARTS WHOSE PART NUMBERS APPEAR AS SHOWN IN THIS MANUAL OR IN SUPPLEMENTS PUBLISHED BY SONY.

TABLE OF CONTENTS

<u>Section</u>	<u>Title</u>	<u>Page</u>
SECTION 1. GENERAL	4
SECTION 2. DISASSEMBLY	9
SECTION 3. ELECTRICAL ADJUSTMENTS	10
SECTION 4. DIAGRAMS		
4-1.	Circuit Boards Location	13
4-2.	Semiconductor Lead Layouts	13
4-3.	Printed Wiring Boards—TUNER Section—	15
4-4.	Schematic Diagrams—TUNER Section—	17
4-5.	Schematic Diagrams—MAIN Section—	21
4-6.	Printed Wiring Boards—MAIN Section—	25
4-7.	Schematic Diagrams—DIGITAL Section—	32
4-8.	Printed Wiring Boards—DIGITAL Section—	35
4-9.	Printed Wiring Boards—DISPLAY Section—	38
4-10.	Schematic Diagrams—DISPLAY Section—	41
4-11.	Schematic Diagram—VDP Section—	44
4-12.	Printed Wiring Board—VDP Section—	47
SECTION 5. EXPLODED VIEWS		
5-1.	Front Panel Section	52
5-2.	Chassis Section	53
5-3.	Main Board Section	54
SECTION 6. ELECTRICAL PARTS LIST	55

MODEL IDENTIFICATION

— Model Number Portion —

STR-D1090
STR-D2090

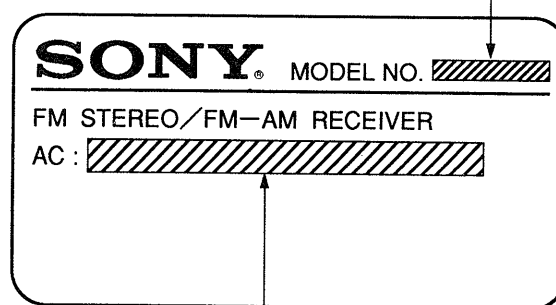

US model: 120V~60Hz 260W
Canadian model: 120V~60Hz 320VA
E model: 120/220/240V~50/60Hz 260W

**ATTENTION AU COMPOSANT AYANT RAPPORT
À LA SÉCURITÉ!**

LES COMPOSANTS IDENTIFIÉS PAR UNE MARQUE  SUR LES DIAGRAMMES SCHÉMATIQUES ET LA LISTE DES PIÈCES SONT CRITIQUES POUR LA SÉCURITÉ DE FONCTIONNEMENT. NE REMPLACER CES COMPOSANTS QUE PAR DES PIÈCES SONY DONT LES NUMÉROS SONT DONNÉS DANS CE MANUEL OU DANS LES SUPPLÉMENTS PUBLIÉS PAR SONY.

Connecting Audio Equipment

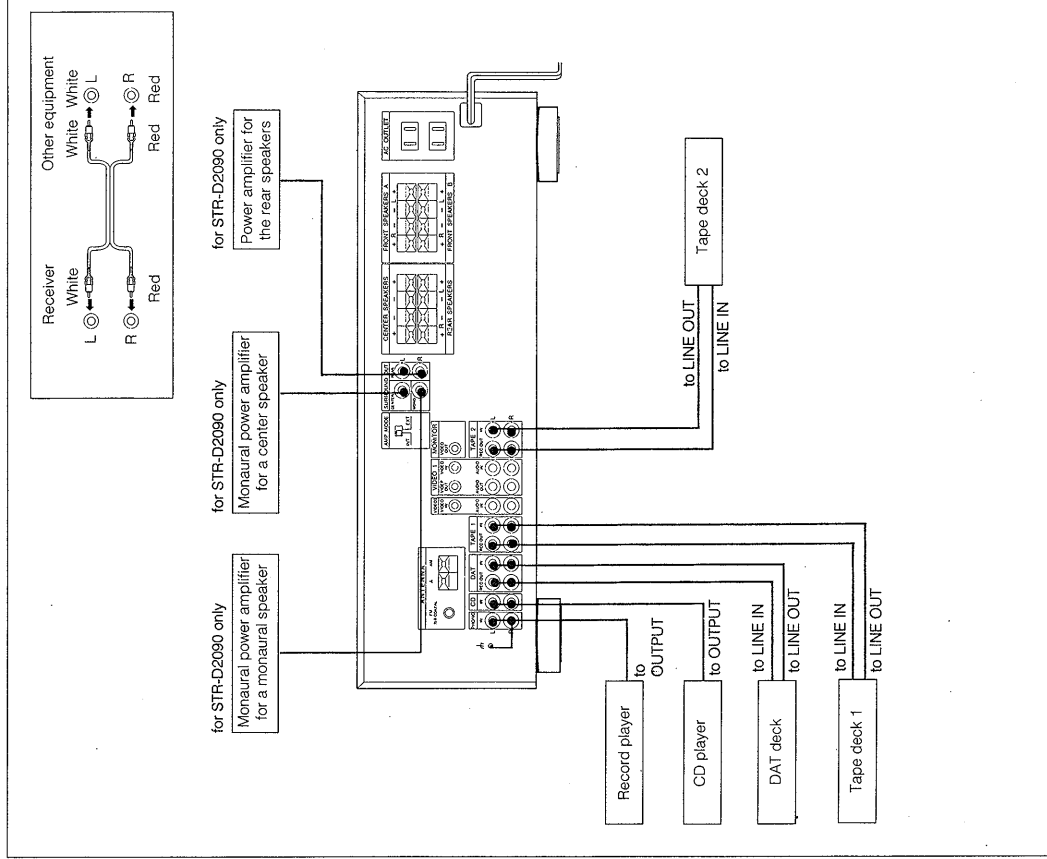

Sound field

- 10 recommended sound field programs (combination of surround and parametric equalizer settings) are preset in the factory for easy use. You can also store up to 10 settings you created in the memory.
- Combined use of the sound field programs and the preset stations allow you to enjoy broadcast listening immediately with the memorized sound field settings.

ON SCREEN function (STR-D2090 only)

- This function allows you to monitor the operation being performed on the monitor TV.

TITLE function (STR-D2090 only)

- With this function, you can edit a title and superimpose on your picture.

Remote commander supplied

- The STR-D1090 is supplied with the RM-U221. The STR-D2090 is supplied with the RM-P321 which can "learn" the various functions of other remote commanders of the infrared type.

On the FUNCTION/SOUND FIELD/PRESET TUNING buttons

There are two kinds of modes for the FUNCTION/SOUND FIELD/PRESET TUNING buttons. One is the "Auto mode" and the other is the "Manual mode".

- **Auto mode**
The FUNCTION/SOUND FIELD/PRESET TUNING buttons are factory preset to the auto mode. After one of the FUNCTION buttons is pressed, these buttons change to the SOUND FIELD mode automatically. When the TUNER button is pressed, these buttons function as numeric buttons.
- **Manual mode**
When you press the POWER switch while pressing the MODE SELECT button, the FUNCTION/SOUND FIELD/PRESET TUNING buttons are set to the manual mode. With the MODE SELECT button, you can select the desired mode.

To return to the auto mode, perform the same procedure again.
This manual describes the operations in the manual mode. However, "Quick Reference" is described in the Auto mode.

On operation

Before making program source connections, be sure to turn the power switch off and unplug the unit.

On cleaning the cabinet

Clean the cabinet, panel and controls with a soft cloth lightly moistened with mild detergent solution. Do not use any type of abrasive pad, scouring powder, or solvent such as alcohol or benzene.

For the customers in the U.S.A.

For detailed safety precautions, see the "IMPORTANT SAFEGUARDS" leaflet.

If you have any question or problem concerning your unit, please consult your nearest Sony dealer.

Introduction

Overview

The STR-D2090/D1090 is an FM Stereo/FM-AM receiver and audio/video control center.
You can enjoy various audio/video program sources with this unit.

TV/video programs

- You can enjoy TV or CATV programs with FM simulcast.
- Sounds from various audio program sources can be added on video tapes during editing.

Tuner

- Precise tuning is ensured by a quartz lock digital synthesizer.
- Station Index system allows you to tune into a station quickly.

Powerful surround sound

- By connecting the power amplifier to the SURROUND OUT jacks of this unit, you can obtain powerful surround sound.

Digital surround processor

- The STR-D2090/D1090 electronically reproduces the reflected sound (early reflection) and reverb sound (reverberation) by using its digital signal processor, and allows you to obtain the acoustics of various situations.
- **DOLBY PRO LOGIC:** The STR-D2090 and STR-D1090 incorporate the Dolby Pro Logic Surround Decoder which has the same functions for playback as movie theaters and gives a theater-like experience in your listening room, naturally reproducing the audio sound field.

Manufactured under license from Dolby Laboratories Licensing Corporation. Additionally licensed under one or more of the following patents: U.S. numbers 3,632,886, 3,746,782, and 3,959,500; Canadian numbers 1,004,603 and 1,037,877; "DOLBY" and the double-D symbol DD are trademarks of Dolby Laboratories Licensing Corporation.

Digital parametric equalizer

- You can enjoy audio program sources with appropriate equalization curve by controlling the level of the desired 3 frequency bands.

Precautions

On safety

- Operate the unit only on 120 V AC, 60 Hz.
- Should any solid object or liquid fall into the cabinet, unplug the unit and have it checked by qualified personnel before operating it any further.
- Unplug the unit from the wall outlet if it is not to be used for an extended period of time. To disconnect the cord, pull it out by grasping the plug. Never pull the cord itself.
- One blade of the plug is larger than the other for the purpose of safety and will fit into the power outlet only one way. If you are unable to insert the plug fully into the outlet, contact your dealer.

Hooking Up the System

Connecting Video Equipment

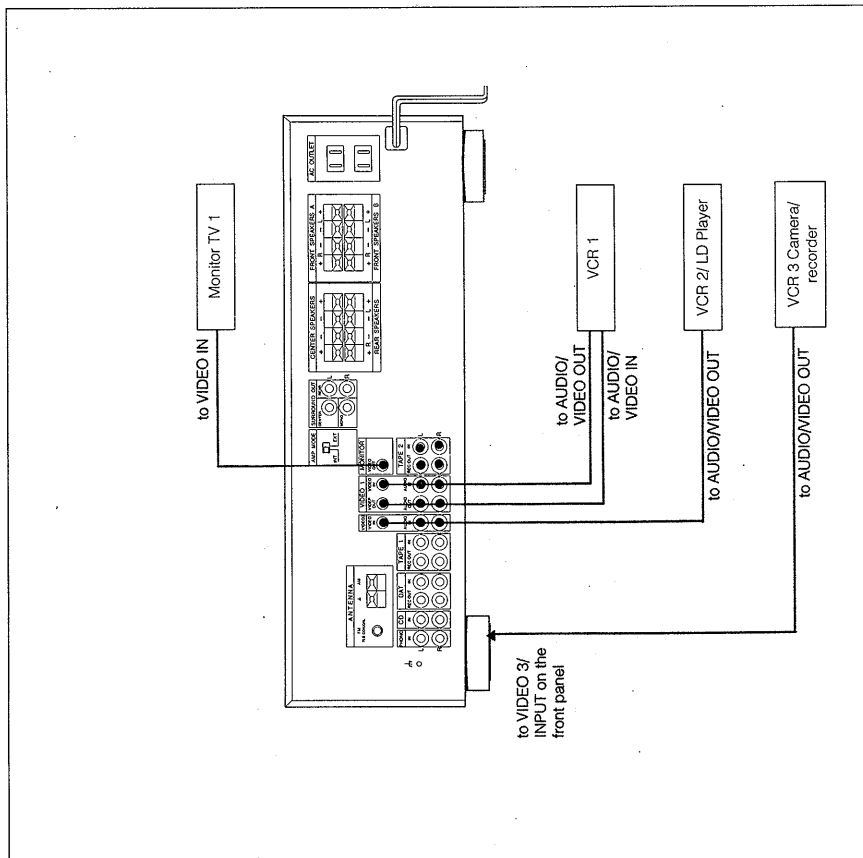

Caution for STR-D2090
 When the MONITOR VIDEO OUT jack is connected and ON SCREEN ON/OFF is set to ON, the cursor mode operation buttons cannot be used for the other functions than the ON SCREEN function.

Connecting Speaker Systems

Front, rear and center speakers can be connected to this unit.

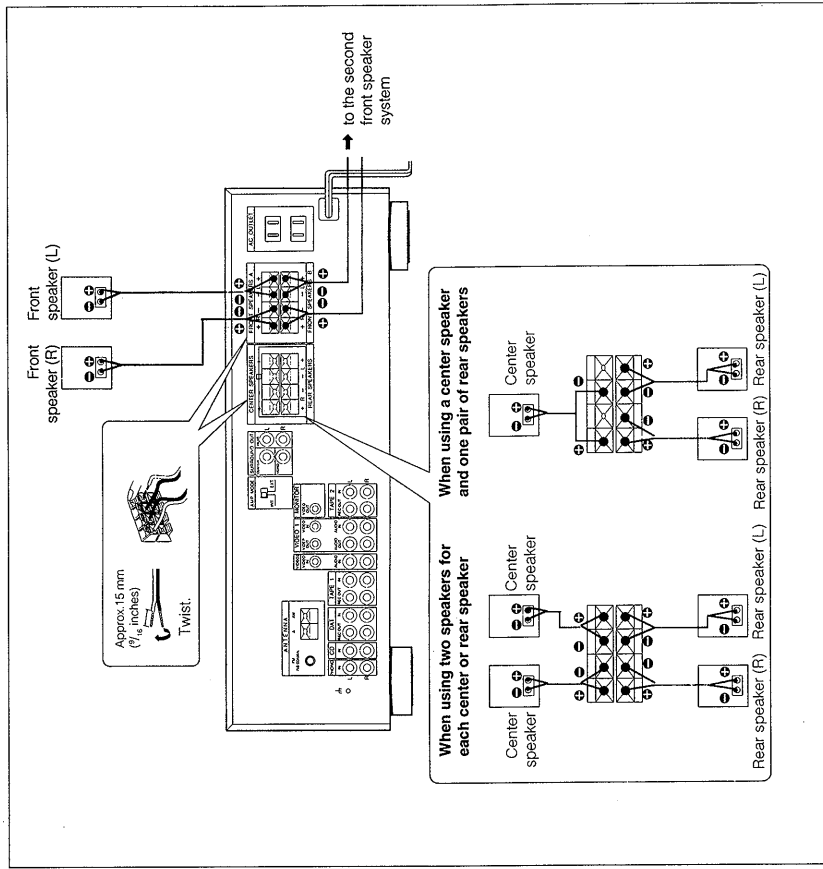

Note

- When connecting the speaker cord to the speaker terminal, make sure that the polarity (+ and -) of the speaker cord is correct. If the polarity is reversed at either speaker, the sound will be distorted and will lack bass.

Speaker impedance and power capability

This receiver is designed to work best with speakers having nominal impedance from 8 to 16 ohms. Be sure to use a speaker system with adequate nominal impedance and power handling capabilities. When using two center speakers, use the speakers having nominal impedance from 4 to 16 ohms.

Hooking Up the System

Connecting the external power amplifier (for STR-D2090 only)

By connecting the external power amplifier to this receiver, you can obtain a powerful sound.

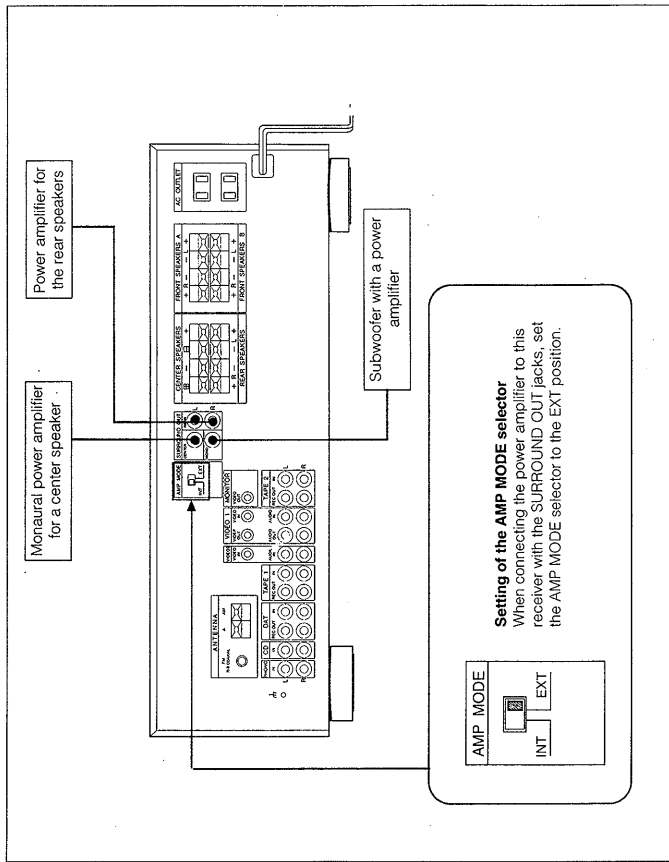

When connecting a monaural power amplifier for a center speaker
Connect the input jack of the power amplifier to the SURROUND CENTER jack of this receiver.

When connecting a subwoofer with a power amplifier
Connect the line input jack of the subwoofer to the SURROUND MONO jack of this receiver.
When using subwoofer not having a power amplifier, connect through a monaural power amplifier.

When connecting a power amplifier for the rear speakers
Connect the input jacks of the power amplifier to the SURROUND OUT REAR jacks of this receiver.

Connecting to the Power Outlet

By connecting the power cord of the other audio equipment to SWITCHED AC OUTLET, this unit can supply the power source to the other audio equipment.

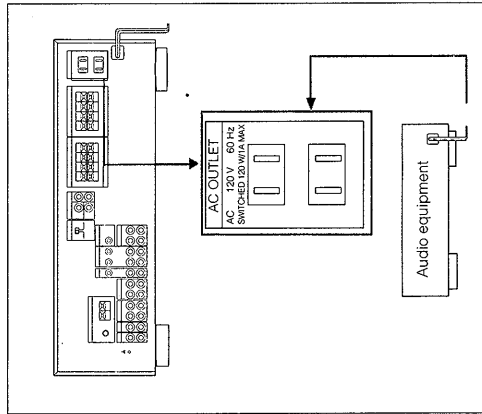

Caution

Be careful that the total power consumption of each equipment connected to the outlets on the receiver does not exceed 120 watts.
Do not connect electrical home appliances such as an electric iron, fan, TV, or other high-wattage equipment to these outlets.

Parts Identification

Front Panel

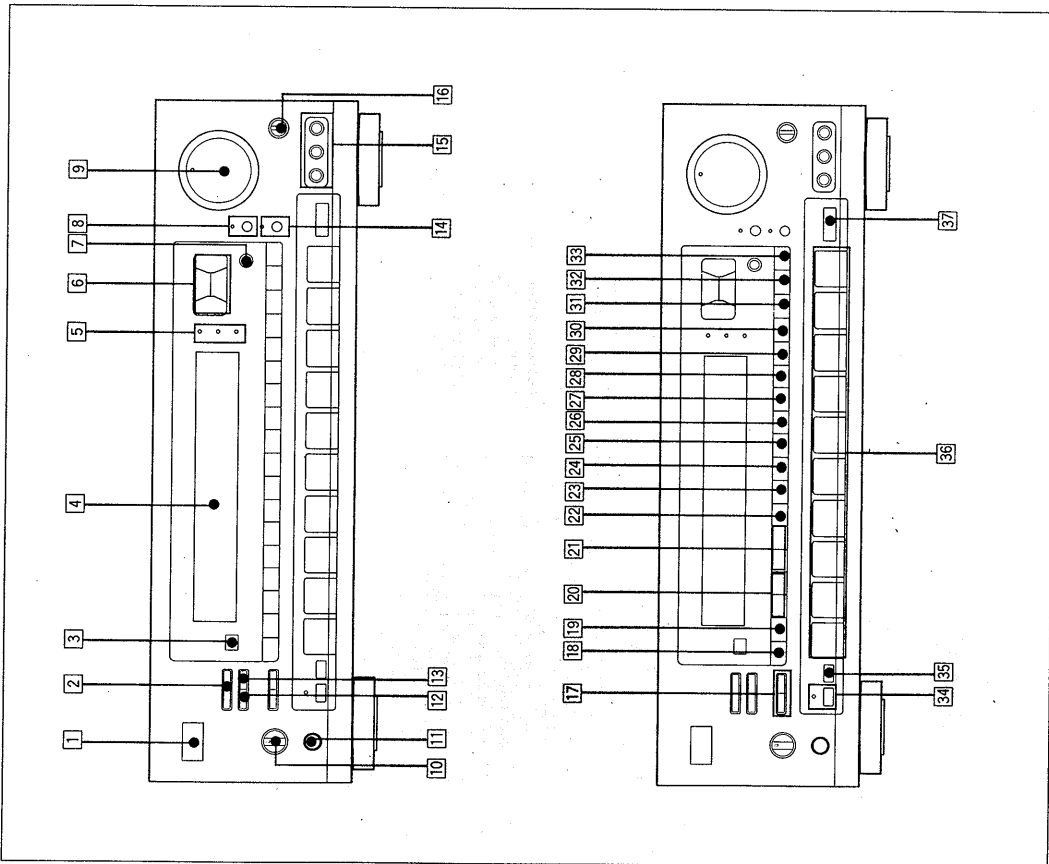

- 1 POWER switch
- 2 ON SCREEN ON/OFF button (STR-D2090 only)
- 3 Remote sensor
- 4 Display window
- 5 CURSOR MODE indicators
(See pages 18, 23, 32, 33, 35, 38.)
- 6 Cursor mode operation buttons
(See pages 8, 18, 23, 32, 33, 35, 38, 40)
- 7 CURSOR MODE/TITLE MENU button
(TITLE MENU button; STR-D2090 only)
(See pages 18, 23, 32, 33, 35, 38, 40.)
- 8 DBFB button and indicator (See page 16.)
- 9 MASTER VOLUME control (See page 16.)
- 10 SPEAKERS selector (See page 16.)
- 11 HEADPHONES jack
- 12 TITLE ON/OFF button (STR-D2090 only)
(See pages 40, 41.)
- 13 TITLE IN/OUT button (STR-D2090 only)
(See page 41.)
- 14 MUTING button and indicator (See page 16.)
- 15 VIDEO 3/INPUT jacks
- 16 BALANCE control (See page 16.)
- 17 EDIT VIDEO/AUDIO buttons (See pages 27, 28.)
- 18 DISPLAY GRAPHIC button (See page 38.)
- 19 DISPLAY INDEX button (See pages 20, 24.)
- 20 INDEX/SELECT TUNING +/- buttons
(See pages 20, 24.)
- 21 PRESET TUNING +/- buttons (See pages 22, 24.)
- 22 TUNING LEVEL button (See page 20.)
- 23 MEMORY button (See pages 18, 21, 23.)
- 24 DIRECT TUNING button (See page 19.)
- 25 FM MODE button (See page 19.)
- 26 FM/AM button (See pages 19, 20.)
- 27 SOUND FIELD LINK button (See page 39.)
- 28 SOUND FIELD ON/OFF button (See pages 32, 33.)
- 29 SOUND FIELD USER/PRESET button
(See pages 35, 38, 39.)
- 30 Dolby PRO LOGIC MODE button
(See pages 31, 32.)
- 31 EQUALIZER FLAT button (See page 38.)
- 32 EQUALIZER SLOPE button (See page 36.)
- 33 EQUALIZER BAND button (See page 38.)
- 34 TAPE 2 MONITOR button and indicator
(See page 26.)
- 35 SHIFT button (See pages 21, 22, 23.)
- 36 FUNCTION/SOUND FIELD/PRESET TUNING buttons
(See page 4.)
- 37 MODE SELECT button

Parts Identification

Remote Commander

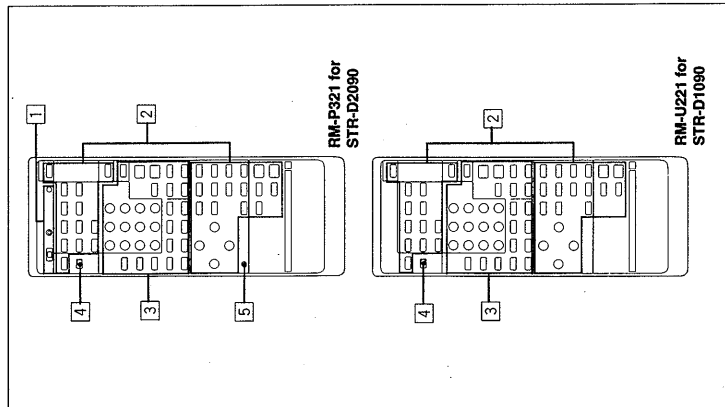

1 Program control section

Mode selector and indicator
 SONY STD: To control Sony equipment.
 USER STD: To control equipment whose remote control functions are stored.
 LEARN: To store functions of other remote commanders emitting infrared rays.
 PROGRAM CLEAR: Clears the stored functions.

2 Receiver control section

FUNCTION:
 DAT, CD, TUNER, PHONO, VIDEO 1, VIDEO 2, VIDEO 3, TAPE, DIGITAL 1, 2: The each function is selected and the each unit enters its operating mode automatically. (DIGITAL 1 and 2 do not function.)
 SYSTEM OFF: Turns off the power of the whole system.
 POWER: Turns on the power of the receiver.

SOUND FIELD buttons
 U/P (user/preset): Selects the USER or PRESET mode.
 MODE: Selects the sound field mode.
 ON/OFF: Turns on/off the sound field system.
 BAND: Selects the frequency band of the equalizer.
 EQ: Turns on/off the setting of TONE controls.
 T. (test) TONE: Generates a pink noise signal that is sent in succession to each speaker.
CURSOR MODE: Select CURSOR MODE.
 CURSOR operating buttons
 REAR LEVEL +/- buttons: Control the volume of rear speakers (surround level).
 CENTER LEVEL +/- buttons: Control the volume of center speaker (surround level).
 DBFB button: Turns on/off the DBFB (Dynamic Bass Feedback).
 MUTING button: Mutes the sound.
 MASTER VOL +/- buttons: Control the receiver volume.
 SLEEP: Set to the SLEEP timer mode. In this mode, the unit is automatically turned off after the designated time.

3 Other equipment control section

Numeric buttons (1 to 0): Designate the number.
 >10: Designate the number more than 10.
 ENTER: Press after designating the TV/VCR channel.
 SHIFT: Select the memory page (A, B or C).
 TV/VIDEO selector: Selects the program to see: TV or VIDEO.
 ANT TV/VTR button: Selects the output signal from the antenna terminal on the VCR, either a TV signal or VCR programs.
 CHIPRESET +/- buttons: Select a preset channel.
 INDEX: Set to the index tuning mode.
 ◀◀/▶▶: Fast winding/manual search
 ●/◀▶: Recording
 ▶▶/▶▶: Play
 ■/■: Stop
 II: Pause
 ◀◀/▶▶: Locates a desired selection.
 REV/FWD: Press ● and REV or FWD at the same time.
 D (disc) SKIP: Disc skip (for a CD player equipped with a multi-disc changer)
 SELECT: Changes the settings of the FUNCTION buttons.

4 SYSTEM/TV mode switch in TV mode (When setting the SYSTEM/TV selector to TV)

Only MUTING, MASTER VOL +/- and the operative buttons in TV section on the list described on the next page can be used.

5 RESET button

Resets the remote commander to the initial state.

SECTION 2 DISASSEMBLY

NOTE: Follow the disassembly procedure in the numerical order given.

2-1. CASE REMOVAL

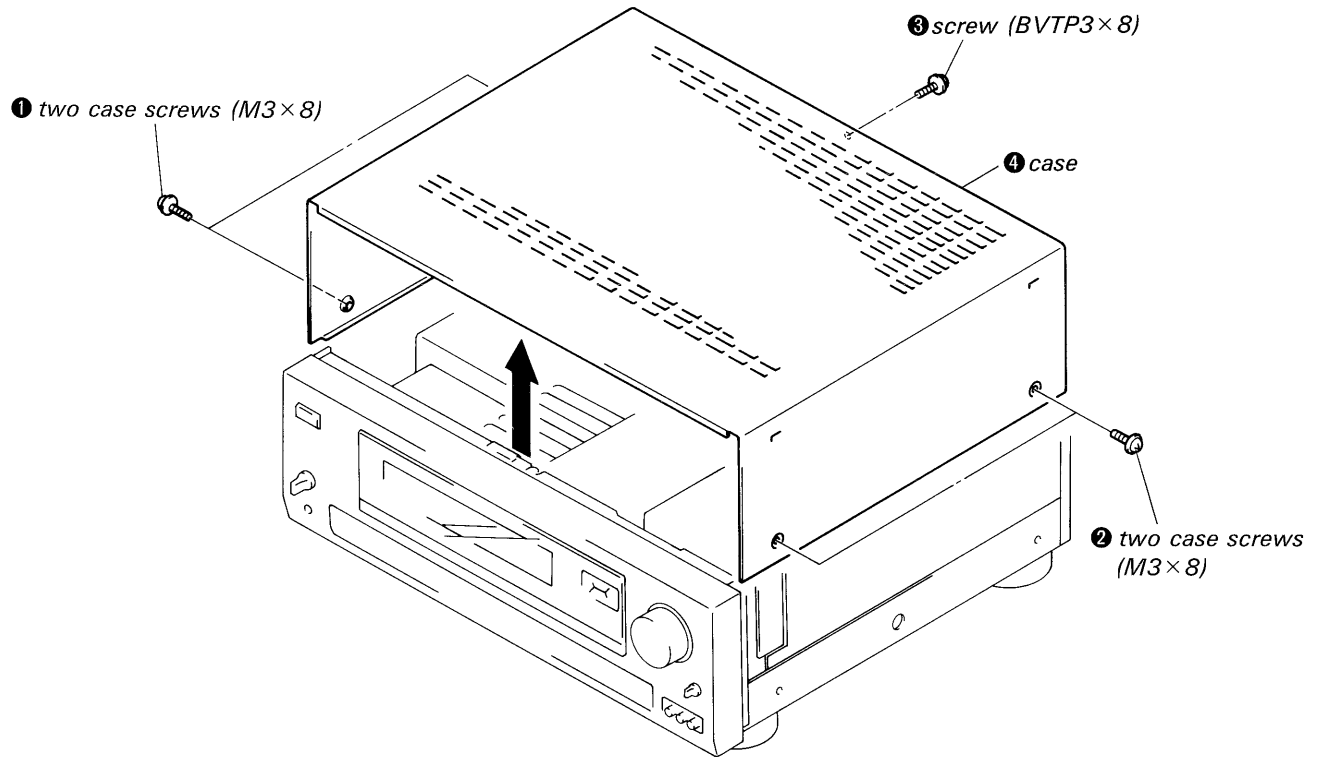

2-2. SURROUND BOARD REMOVAL

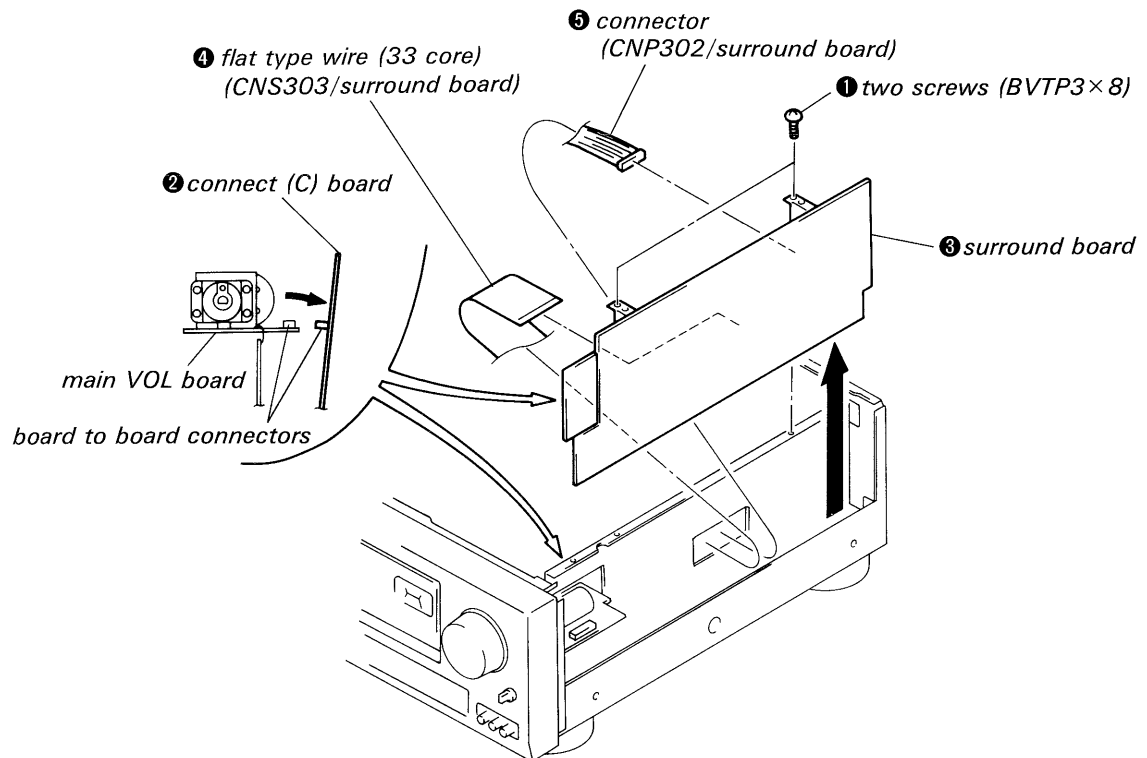

SECTION 3 ELECTRICAL ADJUSTMENTS

FM SECTION

• FM Discriminator (NULL) Adjustment

Setting :

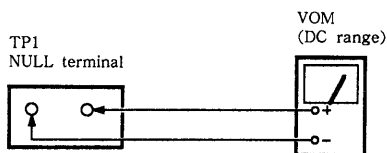
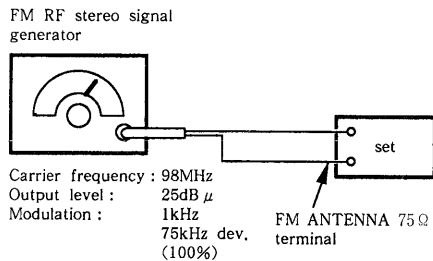

Procedure :

1. Tune the set to 98MHz.
2. Adjust T21 for 0V reading on the VOM.

Note : FM Tuning level adjustment should be made after FM discriminator adjustment.

• FM Tuning Level Adjustment

Setting :

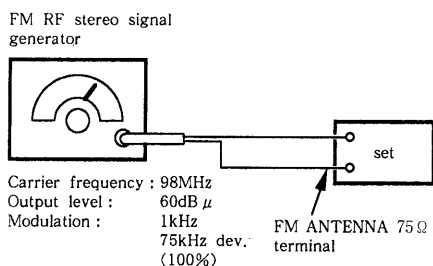

Procedure :

1. Tune the set to 98MHz.
2. Adjust RV24 so that the Voltage of IC10 @ pin is set to low.

Note on Ceramic Filter (CF1, 2) Replacement. (DISPLAY BOARD)

This set employs two ceramic filters (CF1, 2) which should have the same color marking to identify their center frequency. Therefore FM IF offset adjustment by (*A, *B) connection is necessary to match the center frequency of the ceramic filters used with FM intermediate frequency.

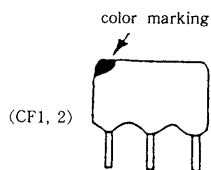

• FM Stereo Separation Adjustment

Setting :

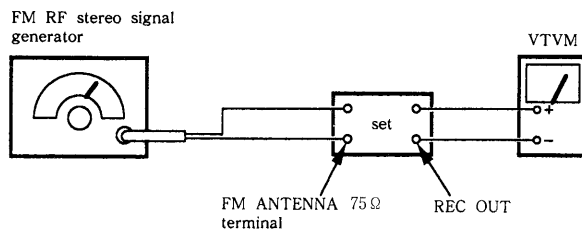

Carrier frequency : 98MHz
Output level : 60dB μ
Modulation :
Audio (1kHz) : 33.75kHz dev. (45%)
Pilot (19kHz) : 7.5kHz dev. (10%)
Sub-channel (38kHz) : 33.75kHz dev. (45%)

Procedure :

Tune the set to 98MHz.

FM stereo signal generator output channel	VTVM connection	VTVM reading (dB)
L-CH	L-CH	Ⓐ
R-CH	L-CH	Ⓑ Adjust RV21 for minimum reading.
R-CH	R-CH	Ⓒ
L-CH	R-CH	Ⓓ Adjust RV21 for minimum reading.

L-CH Stereo separation : Ⓐ - Ⓑ

R-CH Stereo separation : Ⓒ - Ⓓ

The separations of both channels should be equal.

○ : short
× : open

Ceramic filter		Connection		FM intermediate frequency (MHz)
Color mark	Center frequency (MHz)	*A (D217)	*B (D218)	
White	10,750	×	○	10,750
Red	10,700	×	×	10,700
Black	10,650	○	×	10,650

• Auto Stop Level Adjustment

Setting :

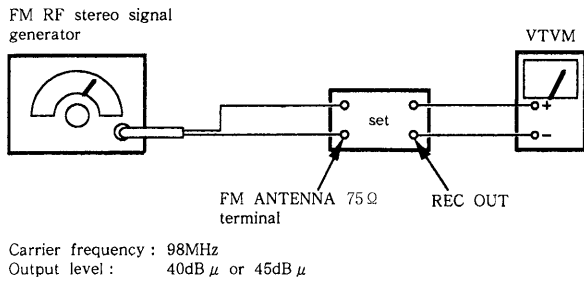

Procedure :

1. Push the TUNING LEVEL switch to High.
2. Adjust RV25 so that the voltage of IC10 ② pin is set to low.

AM SECTION

• AM Tuning Level

Setting :

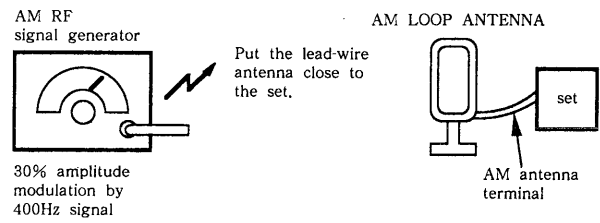

Procedure :

1. Tune the set to 1,050kHz.
2. Adjust the RV22 so that the voltage of IC10 ② pin is set to low.

Adjustment Location:

[TUNER VIDEO BOARD] – Component side –

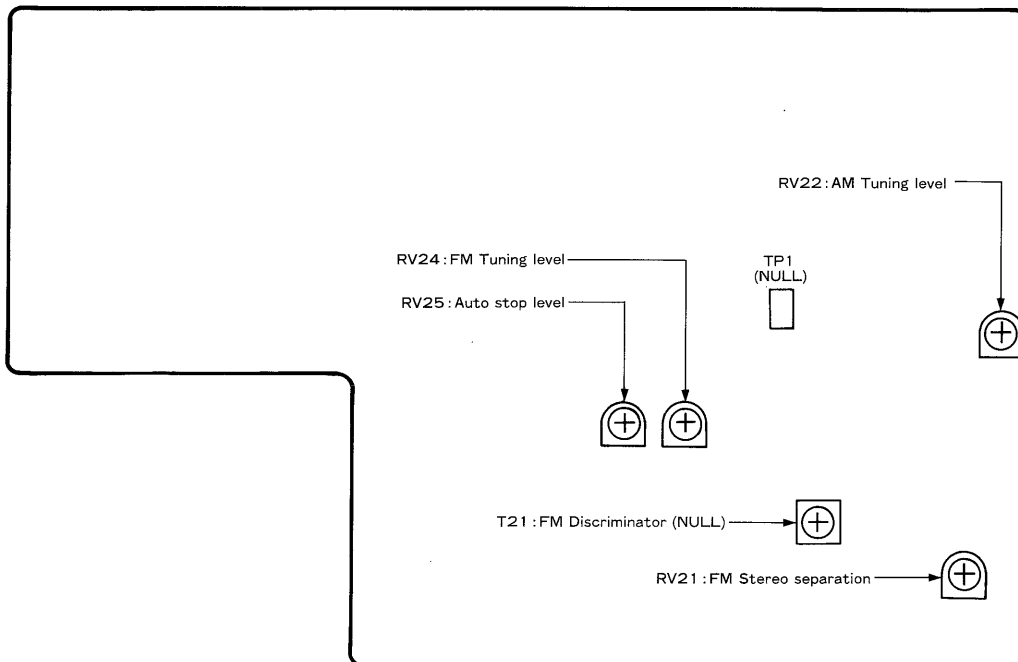

ONSCREEN SECTION

Color Burst Signal Adjustment

Setting:

Signal: None
Frequency counter: TP101

Procedure:

Adjust to 3.579545MHz with CT101

H.sync Signal Adjustment

Setting:

Signal: None
Frequency counter: TP106

Procedure:

Adjust to 15.734kHz with RV105

Color Reproducibility Adjustment

Procedure:

1. Push **RTA** and **7** buttons at once while pushing **TAPE 2** button
2. Adjust the picture frame as shown in Fig. A when using a color bar chart for adjustment with RV104

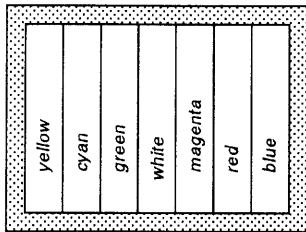

Fig. A. (picture of monitor screen)

Clock-High Adjustment

Setting:

Signal: None
Frequency counter: TP103

Procedure:

1. Short TP104 and GND
2. Adjust to 23.5MHz with RV105

Clock-Low Adjustment

Setting:

Signal: None
Frequency counter: TP103

Procedure:

1. Short TP105 and GND
2. Adjust to 18.9MHz with RV106

Adjustment Location:

[ONSCREEN BOARD] — Component side —

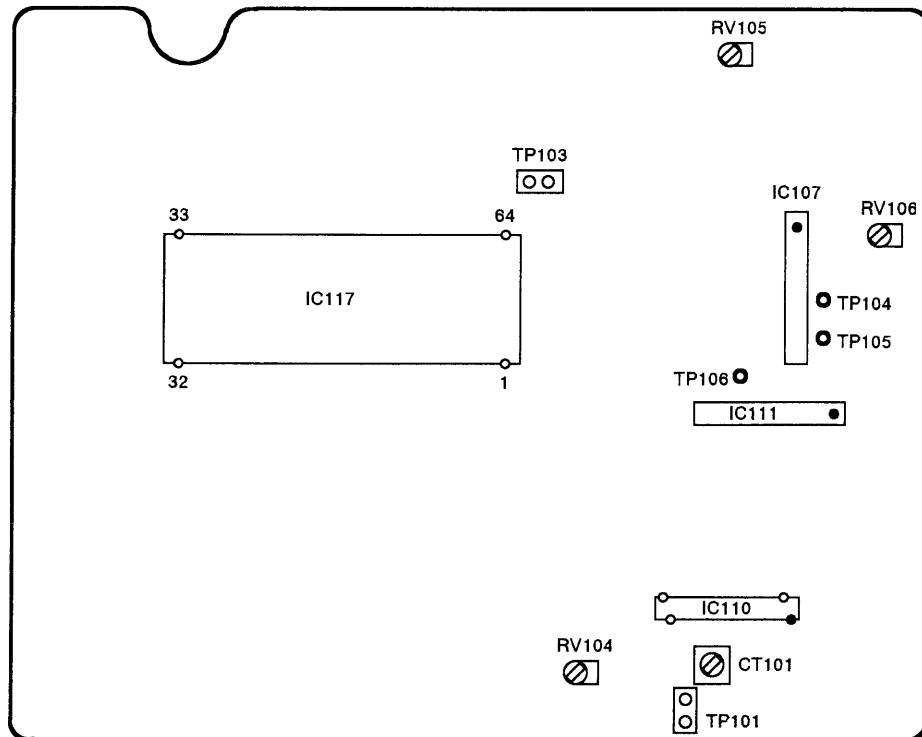

SECTION 4 DIAGRAMS

4-1. CIRCUIT BOARDS LOCATION

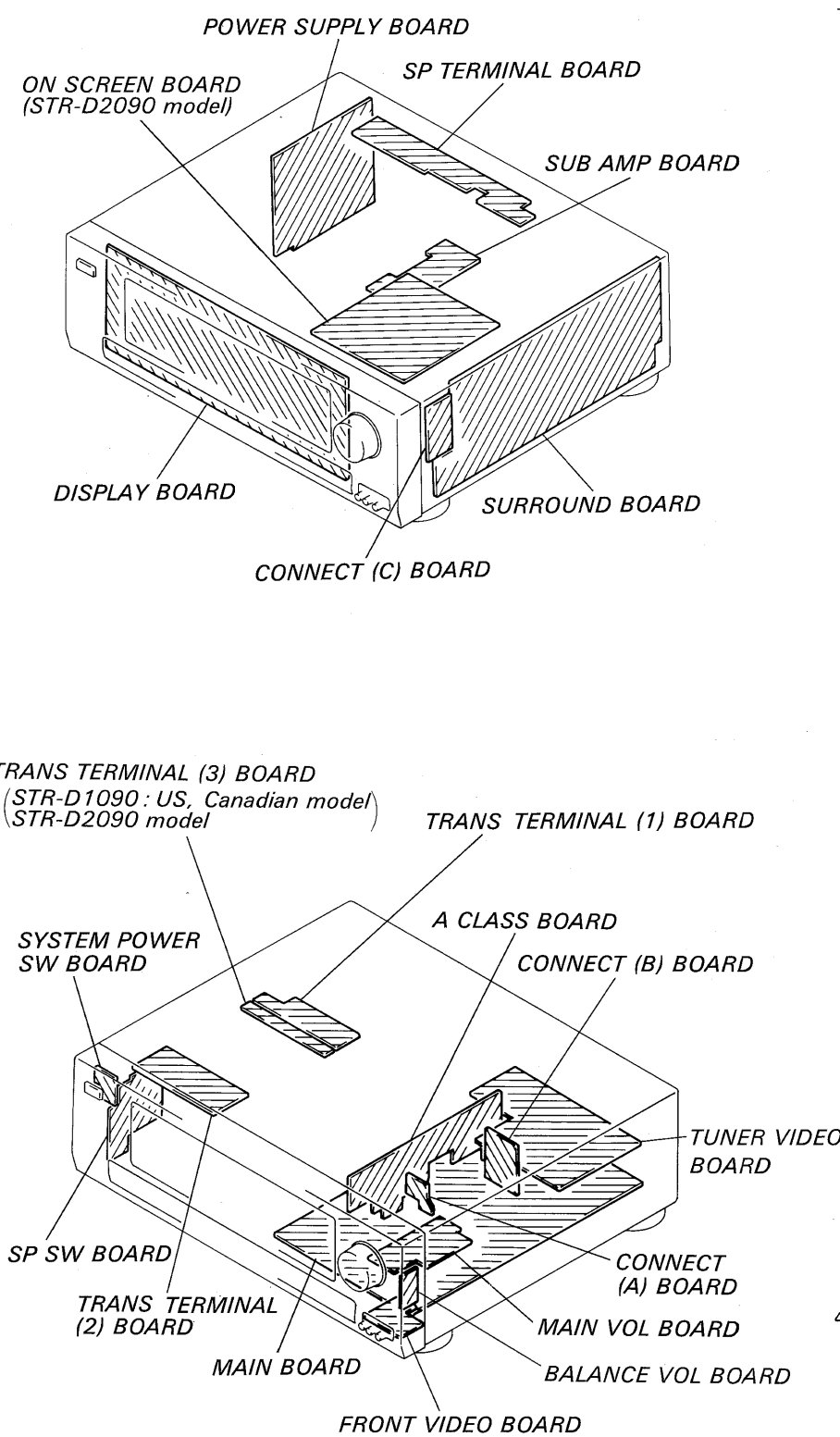

4-2. SEMICONDUCTOR LEAD LAYOUTS

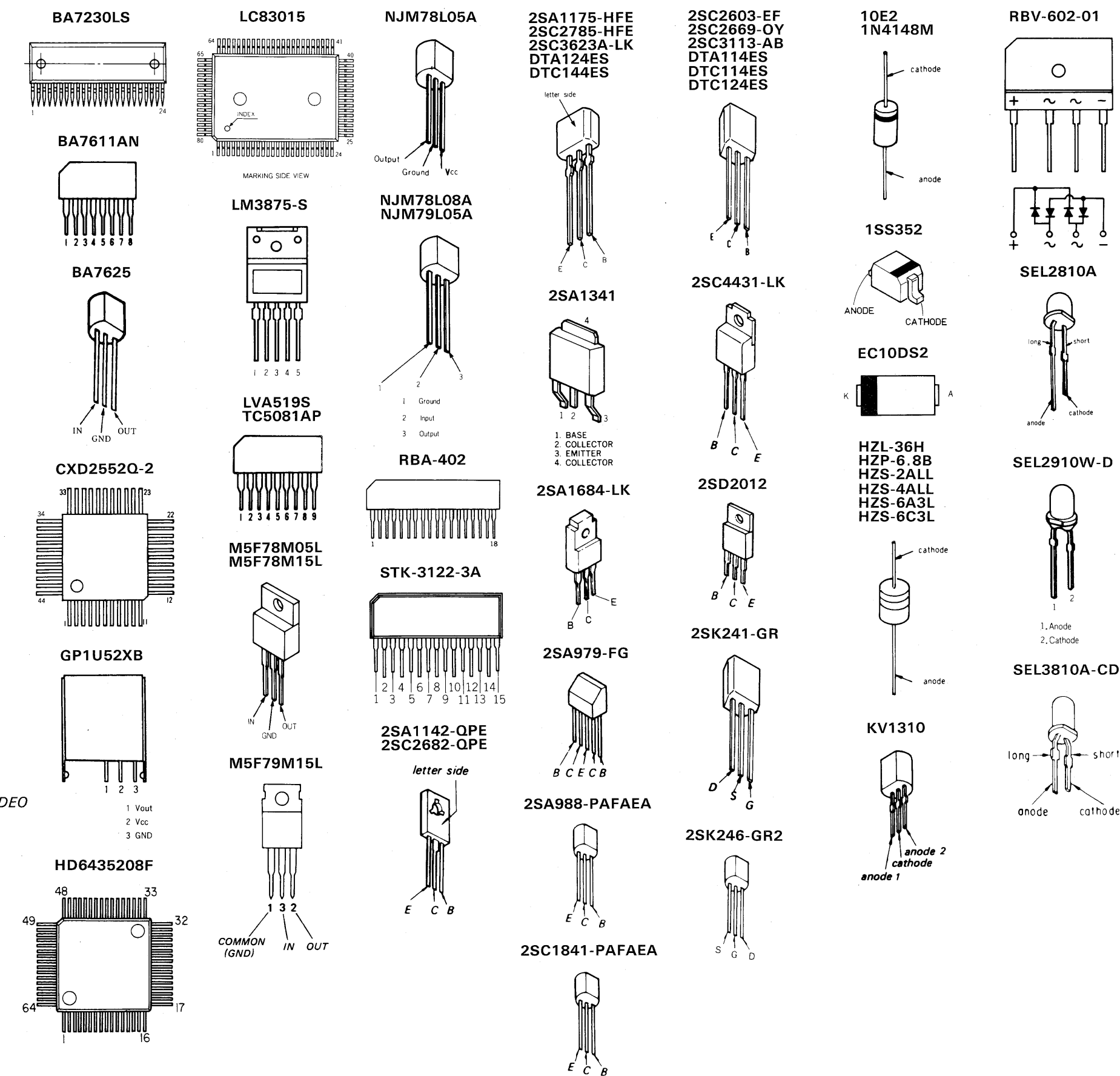

4-3. PRINTED WIRING BOARDS - TUNER Section -

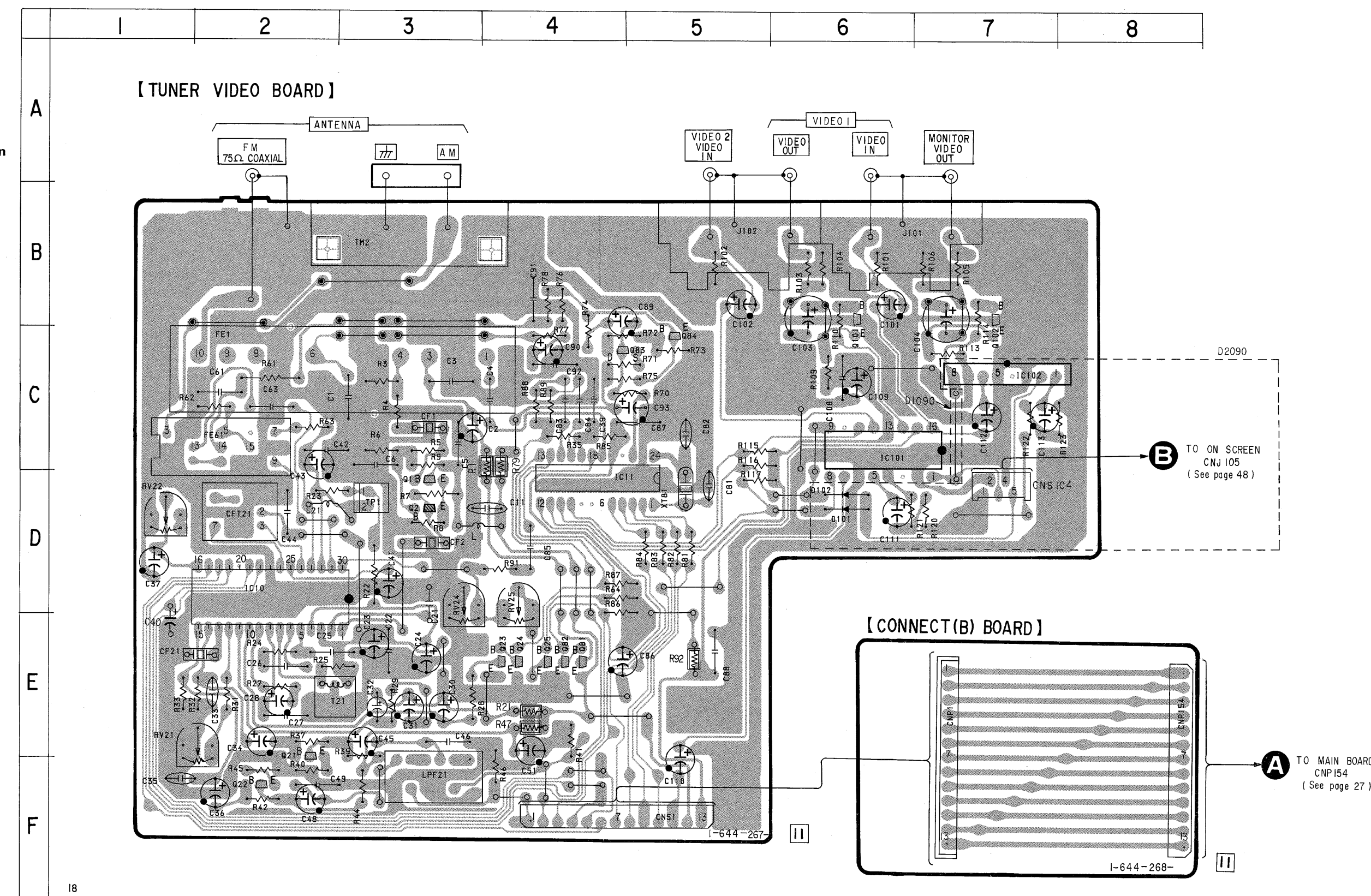

● Semiconductor Location

Ref. No.	Location
D101	D-6
D102	D-6
IC10	D-2
IC11	D-4
IC101	C-6
IC102	C-7
Q1	D-3
Q2	D-3
Q21	E-2
Q22	F-2
Q23	E-4
Q24	E-4
Q25	E-4
Q81	E-4
Q82	E-4
Q83	C-4
Q84	C-5
Q101	B-6
Q102	B-7

Note:
 ○ — parts extracted from the component side.
 ● — parts extracted from the conductor side.
 ● ■ — parts mounted on the conductor side.

4-4. SCHEMATIC DIAGRAM —TUNER Section—

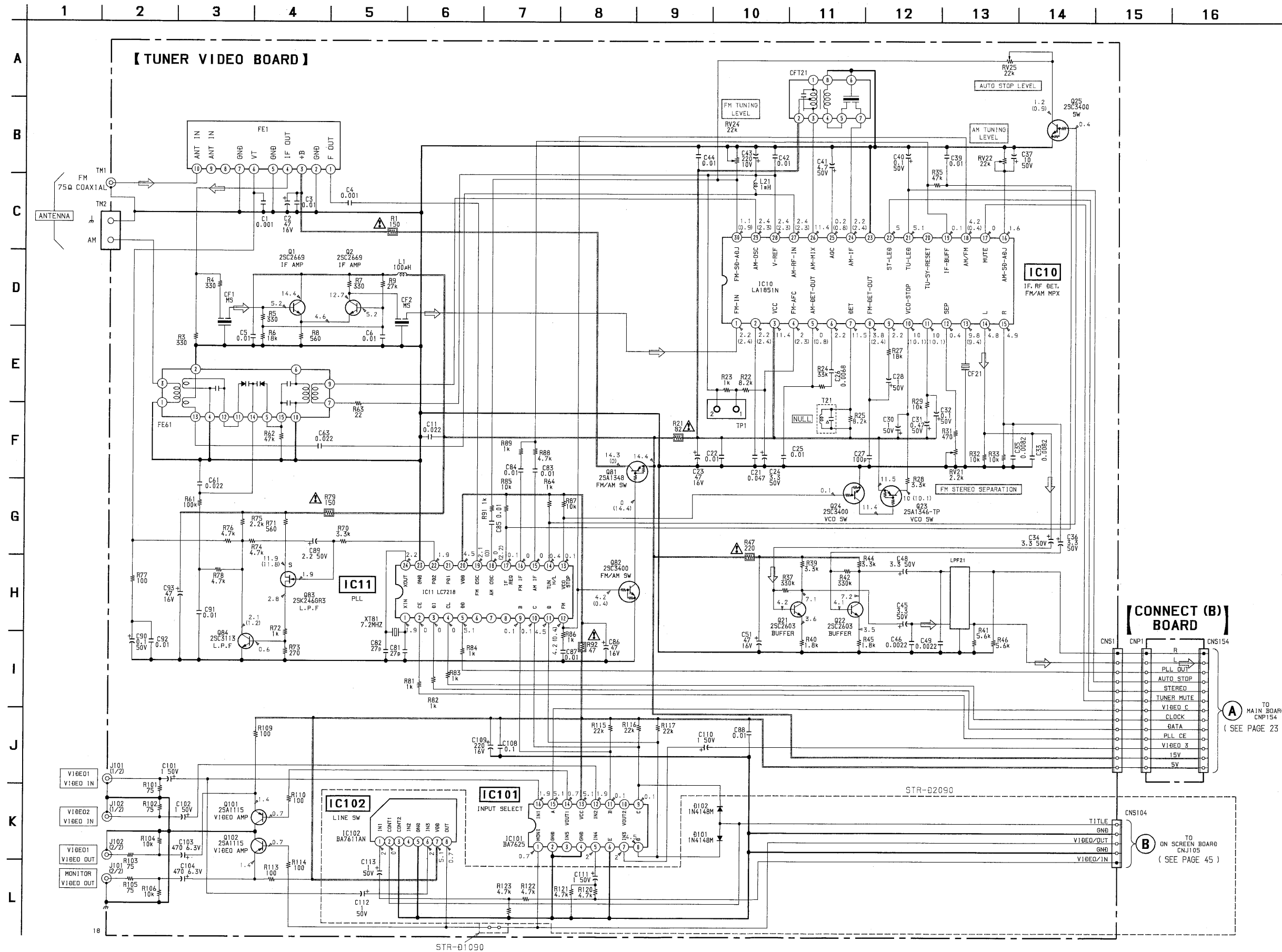

- Note:**
- All capacitors are in μF unless otherwise noted. pF : μpF 50WV or less are not indicated except for electrolytics and tantalums.
 - All resistors are in Ω and $\frac{1}{4}\text{W}$ or less unless otherwise specified.
 - : nonflammable resistor.

Note: The components identified by mark or dotted line with mark are critical for safety. Replace only with part number specified.

Note: Les composants identifiés par une marque sont critiques pour la sécurité. Ne les remplacer que par une pièce portant le numéro spécifié.

- : B+ Line
- : B- Line
- : adjustment for repair.
- Voltages are dc with respect to ground under no-signal (detuned) conditions.
- Voltages are taken with a VOM (Input Impedance $10\text{M}\Omega$). Voltage variations may be noted due to normal production tolerances.
- Signal path. : FM

● IC Block Diagrams

IC10 LA1851N

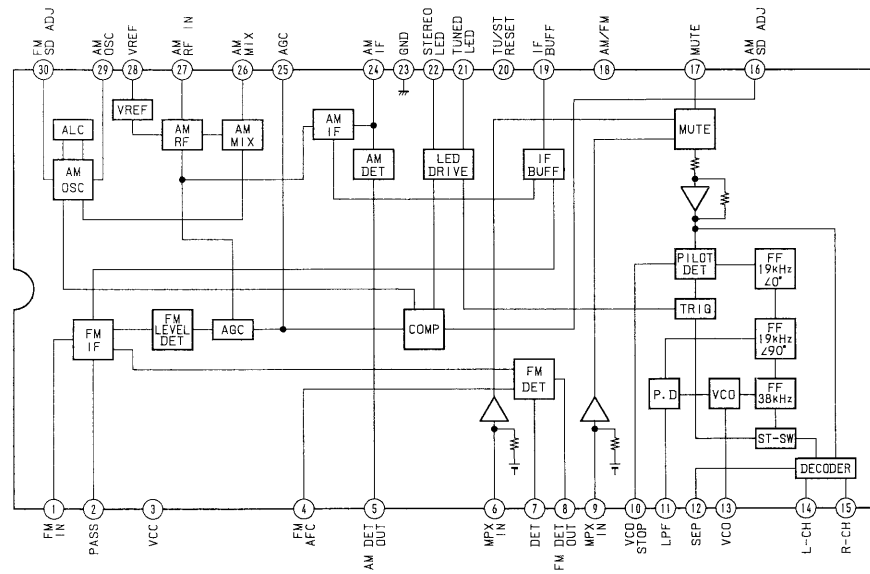

IC101 BA7625

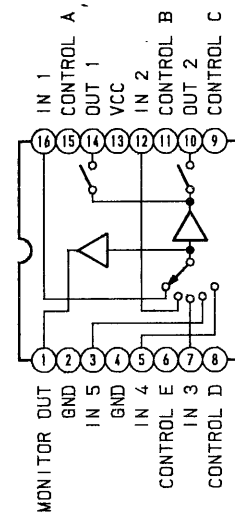

IC11 LC7218

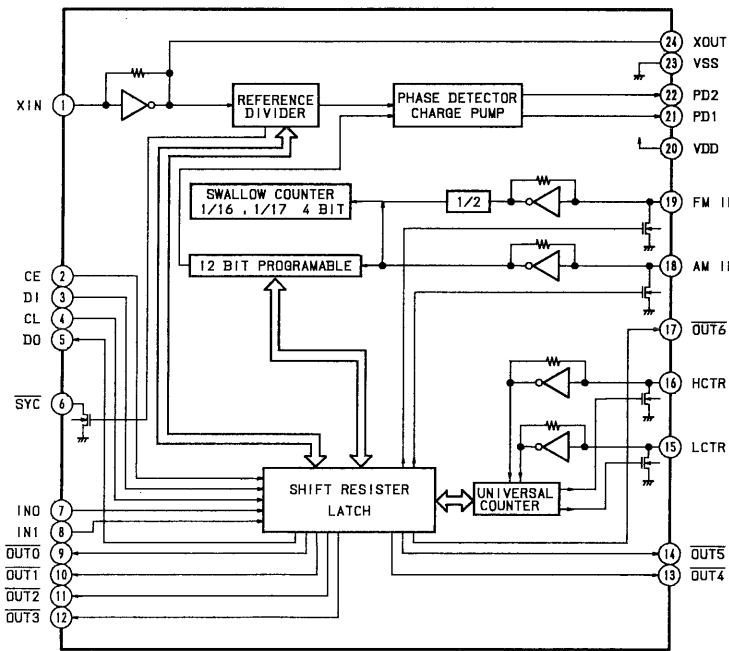

IC102 BA7611AN

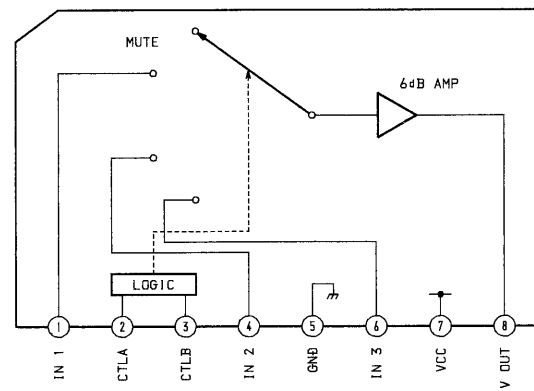

4-5. SCHEMATIC DIAGRAM —MAIN Section—

● IC Block Diagrams

IC231 LB1639

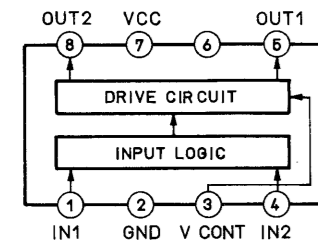

IC510, 511 LC7822

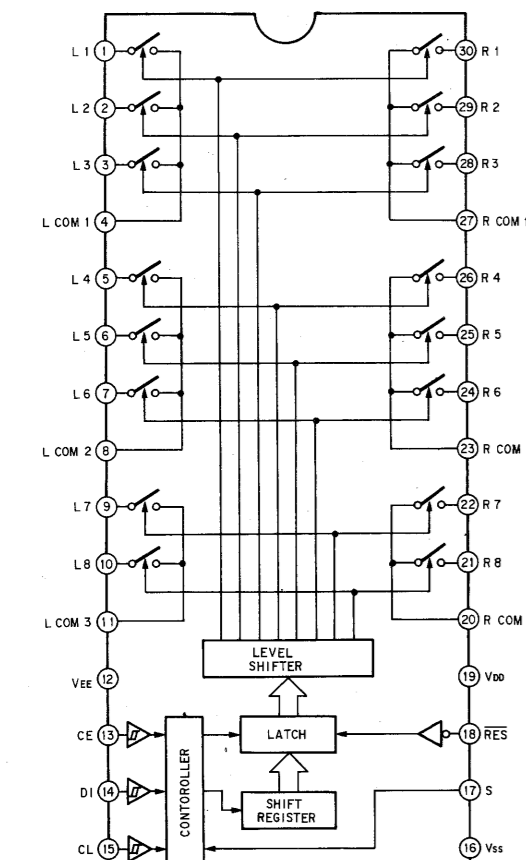

Note:

- All capacitors are in μF unless otherwise noted. pF : μF 50WV or less are not indicated except for electrolytics and tantalums.
- All resistors are in Ω and $1/4\text{W}$ or less unless otherwise specified.
- : nonflammable resistor.

Note:

The components identified by mark or dot are critical for safety. Replace only with part number specified.

Note:

Les composants identifiés par une marque sont critiques pour la sécurité. Ne les remplacer que par une pièce portant le numéro spécifié.

- : B+ Line
 - : B- Line
 - : adjustment for repair.
 - Voltages are dc with respect to ground under no-signal (detuned) conditions.
 - Voltages are taken with a VOM (Input Impedance 10M Ω). Voltage variations may be noted due to normal production tolerances.
 - Signal path.
 - : FM
 - : CD
- CND : Canadian

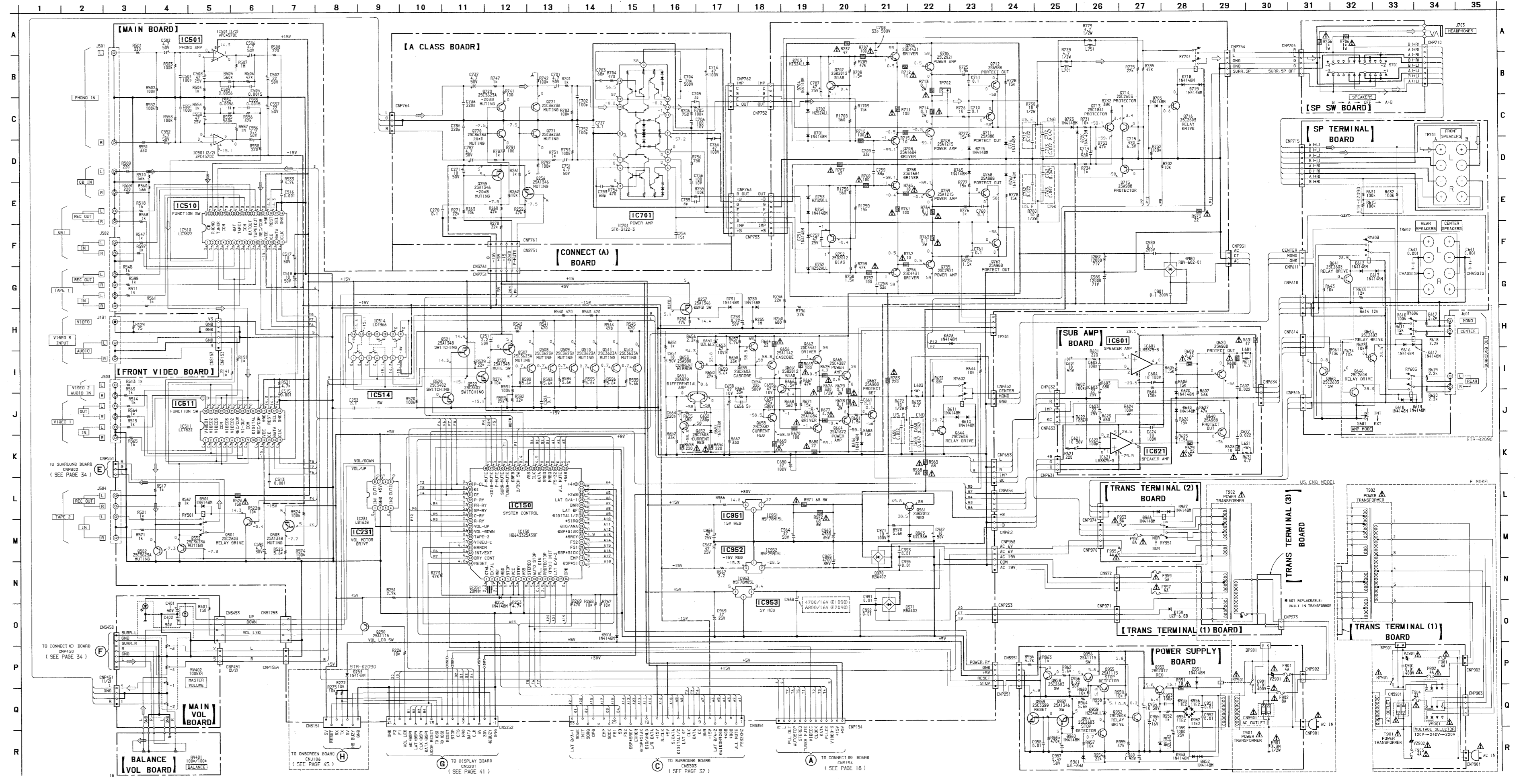

4-6. PRINTED WIRING BOARDS—MAIN Section—
 • See page 13 for Circuit Boards Location and Semiconductor Lead Layouts.

• Semiconductor Location

Ref. No.	Location	Ref. No.	Location	Ref. No.	Location
D150	K-29	D963	H-9	Q655	J-7
D252	F-14	D966	K-25	Q656	J-7
D253	E-12	D967	K-25	Q657	K-9
D501	I-18	D970	G-7	Q658	I-9
D610	H-10	D971	G-9	Q662	J-8
D611	H-10	D973	F-13	Q663	J-9
D612	B-11	D980	H-13	Q664	K-9
D613	B-11			Q665	K-8
D616	B-16	IC150	F-14	Q667	J-9
D617	B-16	IC231	G-13	Q702	K-16
D618	B-14	IC501	D-17	Q704	J-17
D619	B-14	IC510	F-17	Q705	K-17
D620	J-2	IC511	H-17	Q708	J-16
D623	G-13	IC514	E-10	Q709	K-15
D640	J-5	IC601	K-2	Q711	J-15
D651	I-8	IC621	K-5	Q712	J-17
D652	I-8	IC701	H-22	Q713	J-16
D654	I-9	IC951	E-8	Q714	J-16
D701	J-16	IC952	D-8	Q715	J-16
D702	J-16	IC953	F-9	Q716	H-12
D703	J-17			Q720	F-22
D704	J-17	Q250	G-12	Q721	F-22
D705	G-13	Q255	F-22	Q752	J-11
D715	J-15	Q256	F-21	Q754	J-10
D716	J-17	Q257	G-12	Q755	K-11
D718	H-13	Q501	I-18	Q758	J-11
D719	H-13	Q502	J-18	Q767	J-10
D720	J-16	Q503	H-16	Q768	J-12
D723	J-17	Q507	E-11	Q770	F-22
D730	H-12	Q508	E-11	Q771	F-22
D731	H-12	Q509	F-10	Q952	B-25
D751	J-10	Q510	F-10	Q953	D-26
D752	J-10	Q511	F-10	Q954	D-25
D753	J-11	Q512	F-11	Q955	C-25
D754	J-12	Q520	E-9	Q956	C-25
D765	J-12	Q521	E-9	Q957	C-25
D766	I-10	Q522	F-10	Q958	D-25
D951	B-26	Q523	E-11	Q959	B-25
D952	E-25	Q524	J-18	Q961	G-9
D953	E-26	Q620	J-2		
D954	E-25	Q640	J-4		
D955	E-25	Q641	B-12		
D956	E-25	Q644	H-10		
D957	E-25	Q645	B-17		
D958	D-25	Q646	B-17		
D959	D-25	Q651	I-8		
D960	C-25	Q652	I-8		
D961	D-25	Q653	I-8		

Note:
 ○ — parts extracted from the component side.
 ● — parts extracted from the conductor side.
 ■ — parts mounted on the conductor side.

CND : Canadian

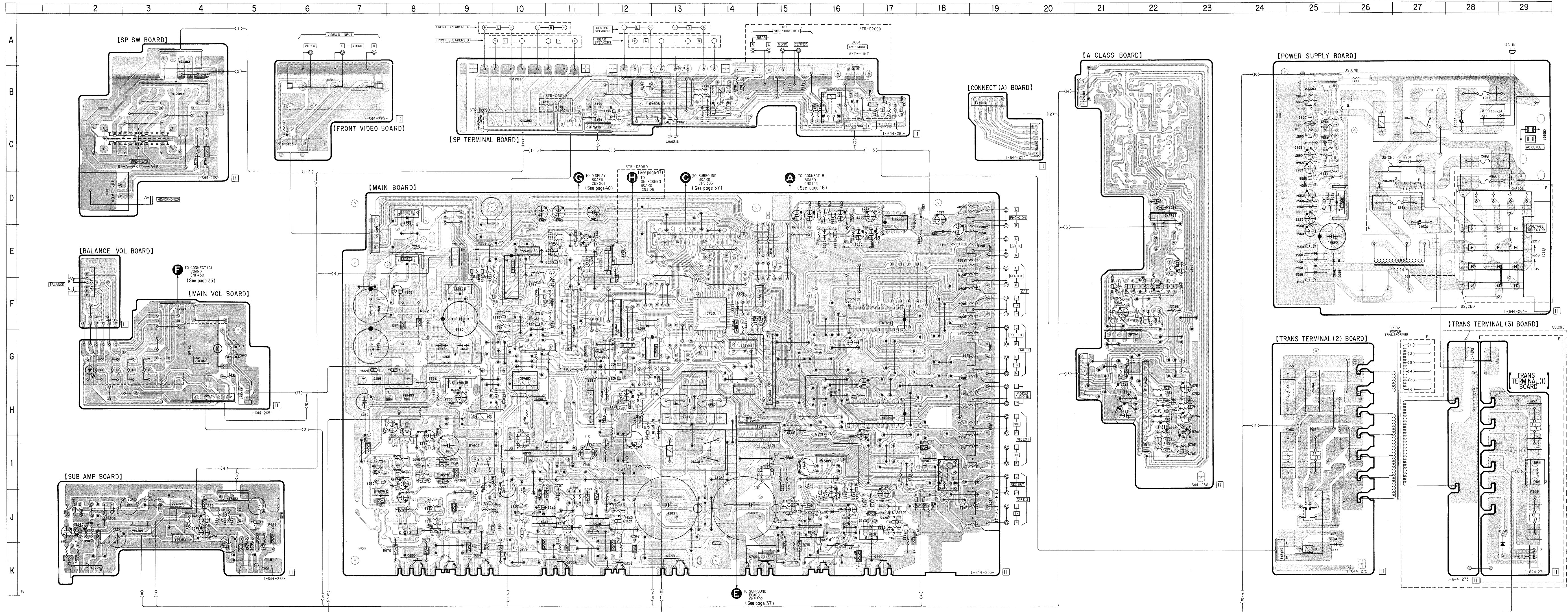

IC301 CS5339-KP

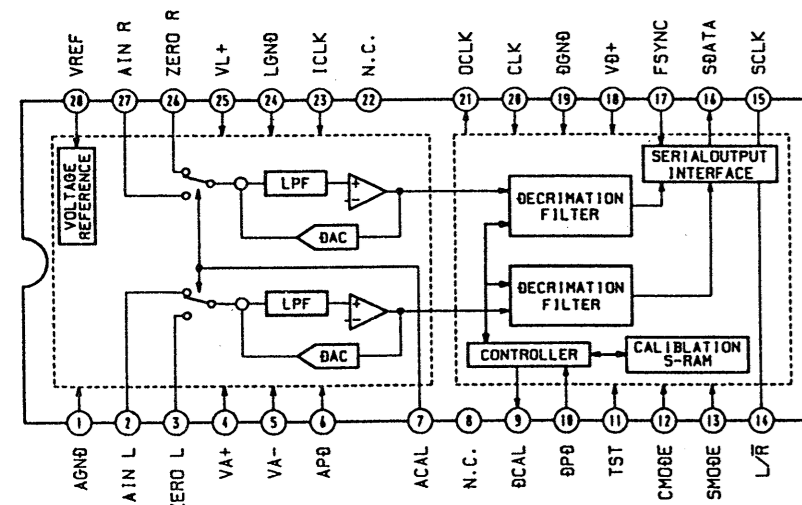

IC307 LC7883K

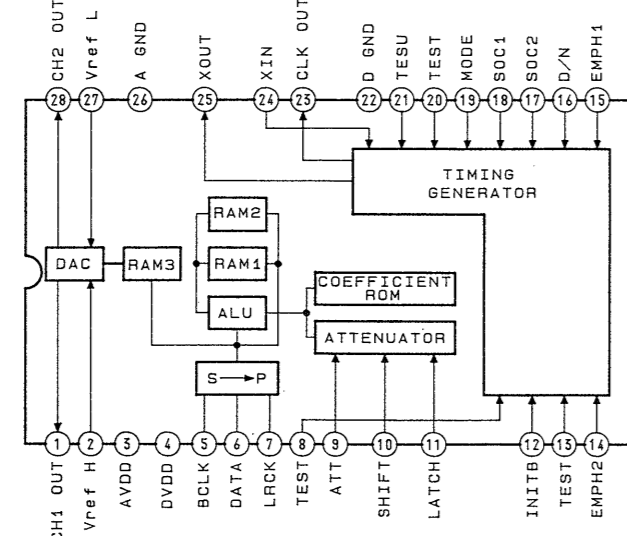

IC405 CXD2560M

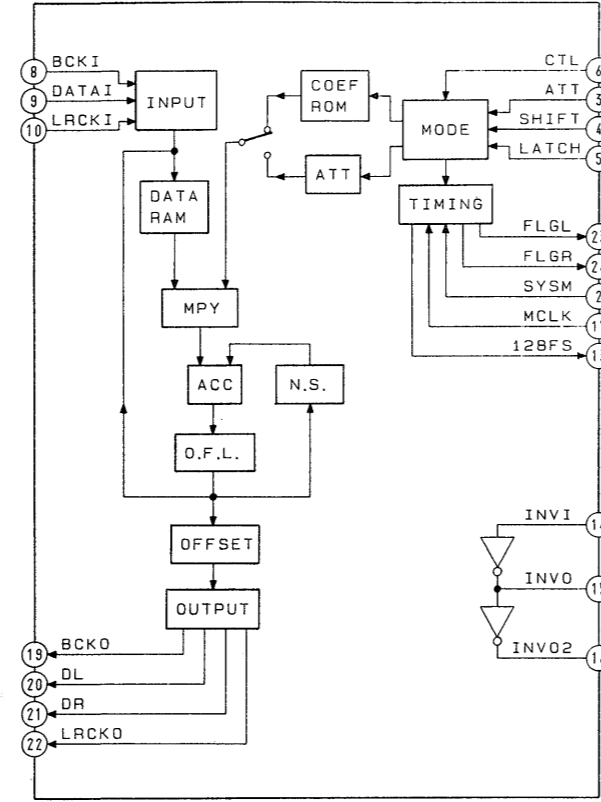

IC406 LC324256-10

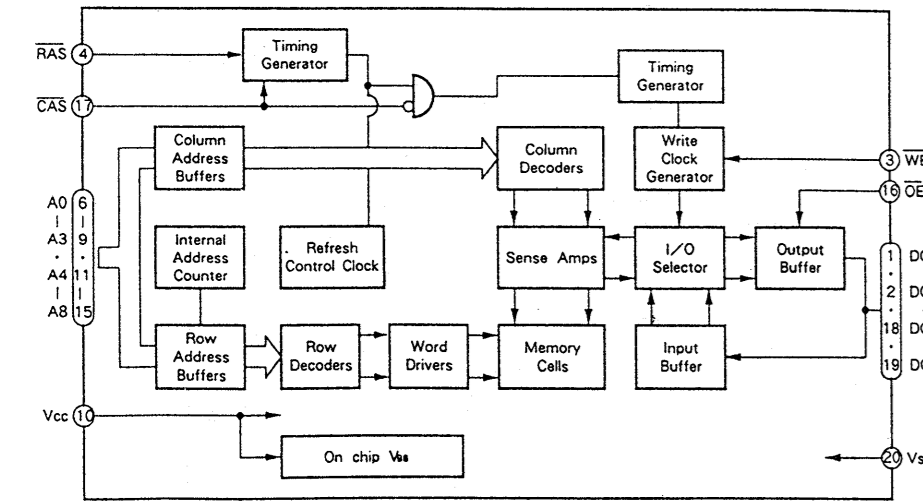

IC408 CXD2552Q-2

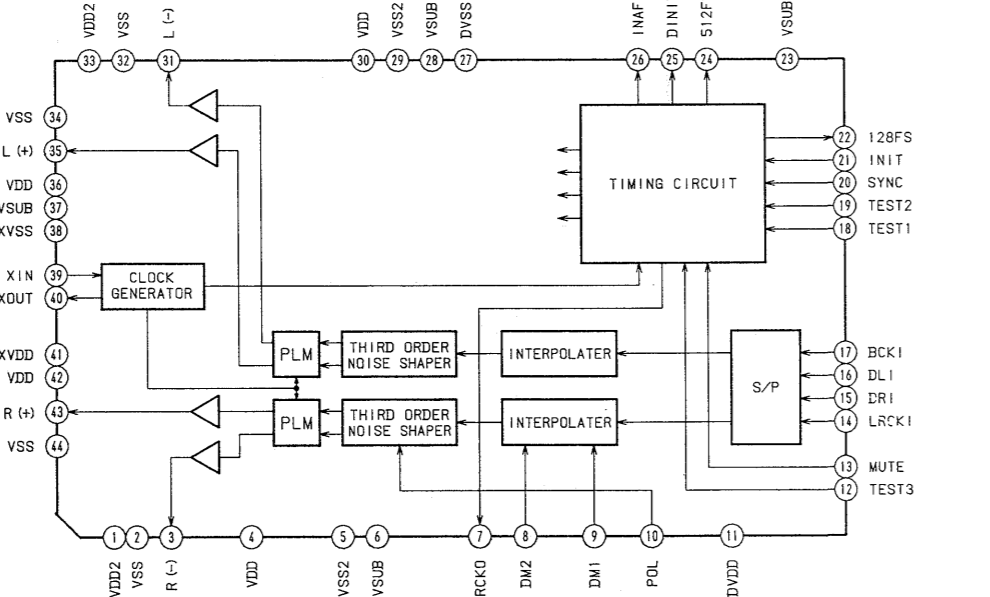

IC409 TC5081AP

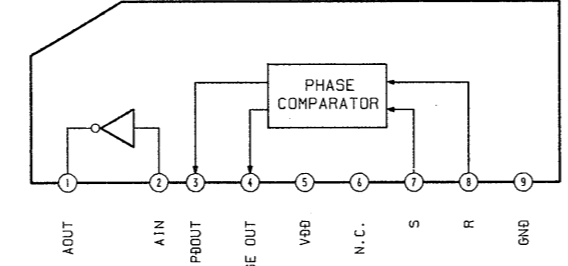

IC417 YM3623B

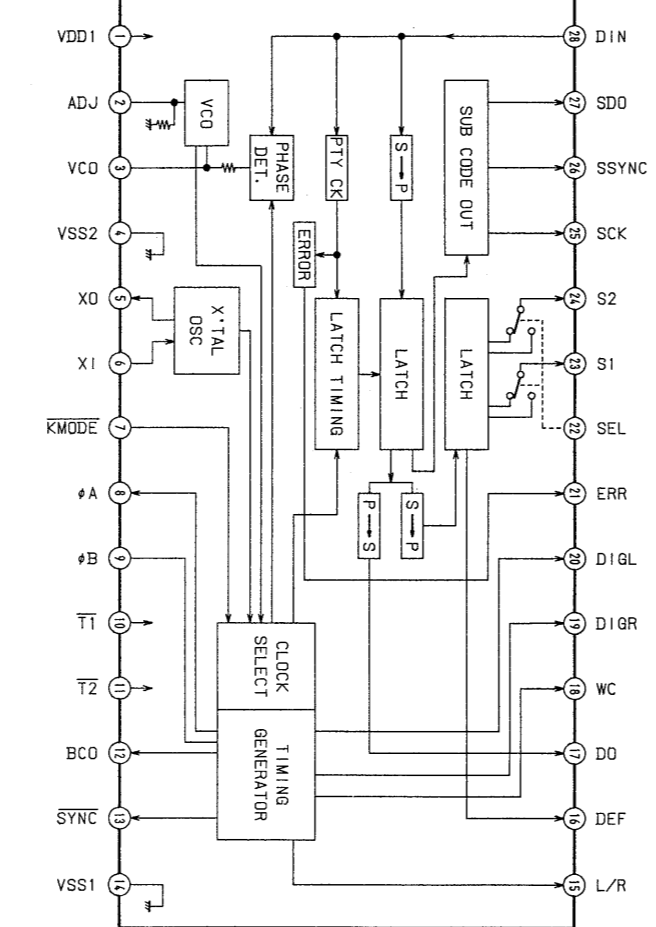

IC410 SN74HC393ANS

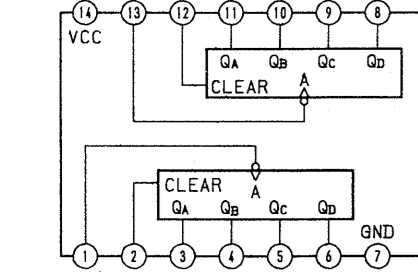

IC418 LC7535

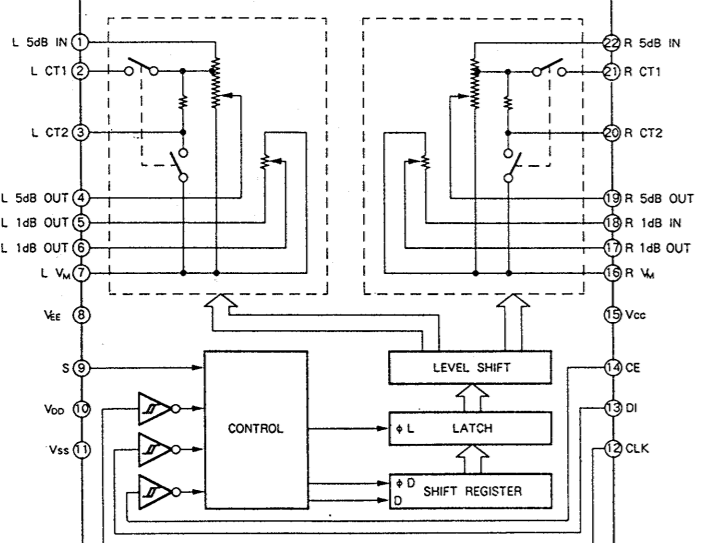

IC420 LA2730

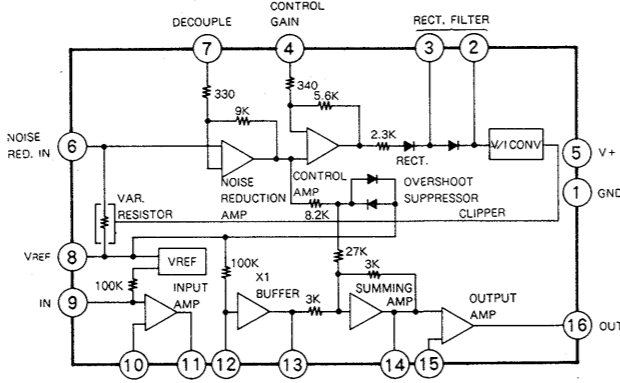

- Note:**
- All capacitors are in μF unless otherwise noted. pF : μF 50WV or less are not indicated except for electrolytics and tantalums.
 - All resistors are in Ω and $1/4\text{W}$ or less unless otherwise specified.
 - : nonflammable resistor.
- Note:**
The components identified by mark **A** or dotted line with mark **A** are critical for safety. Replace only with part number specified.
- Note:**
Les composants identifiés par une marque **A** ou une ligne pointillée avec la marque **A** sont critiques pour la sécurité. Ne les remplacer que par une pièce portant le numéro spécifié.
- : B+ Line
 - : B- Line
 - : adjustment for repair.
 - Voltages are dc with respect to ground under no-signal (detuned) conditions.
 - Voltages are taken with a VOM (input impedance 10M Ω). Voltage variations may be noted due to normal production tolerances.
 - Signal path: : FM

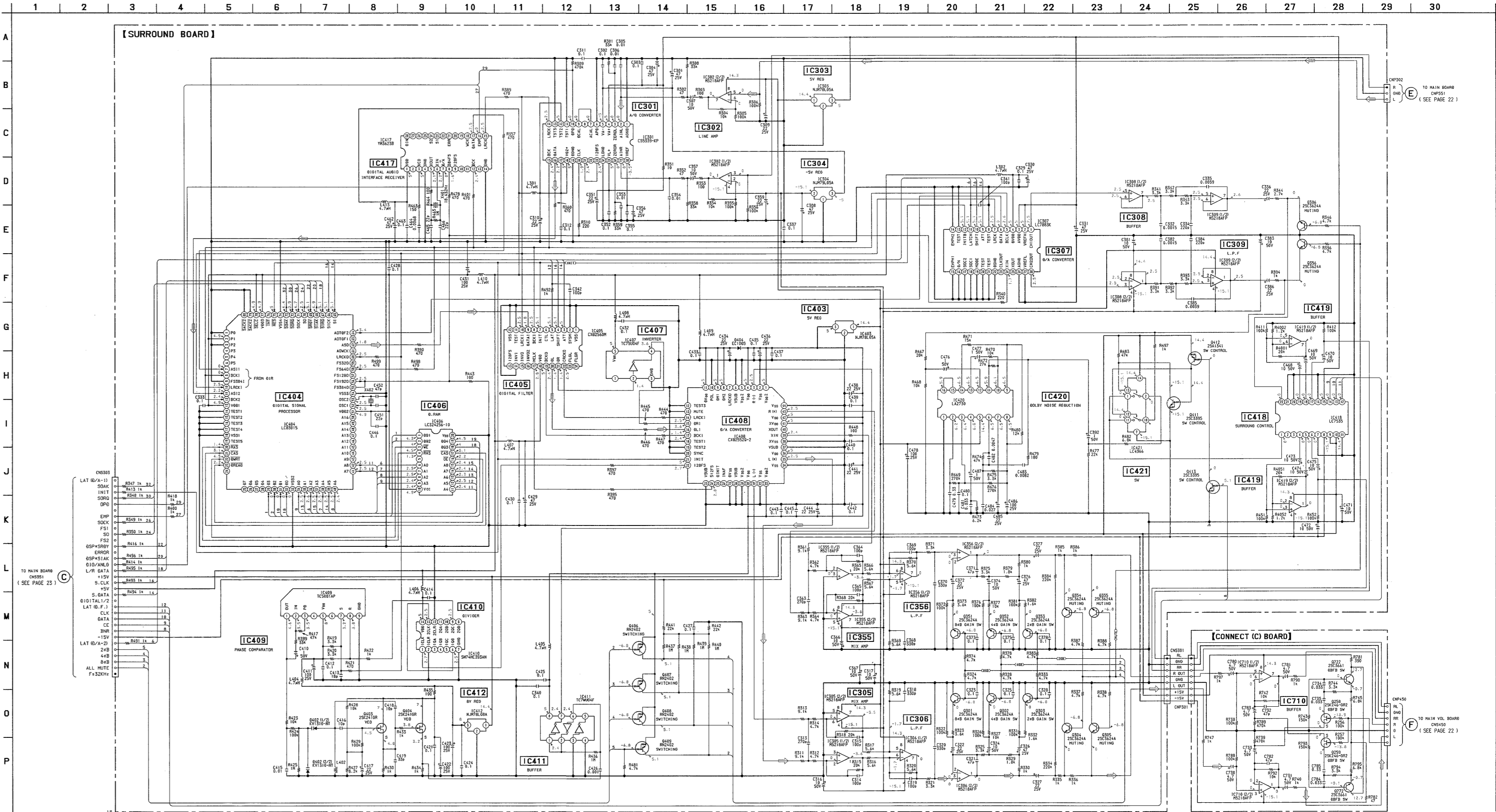

4-8. PRINTED WIRING BOARDS —DIGITAL Section—
 • See page 13 for Circuit Boards Location and Semiconductor Lead Layouts.

● Semiconductor Location

Ref. No.	Location	Ref. No.	Location
D402	D-8	Q258	B-2
D404	C-7	Q259	B-2
		Q301	C-4
IC301	C-13	Q302	B-4
IC302	B-12	Q303	B-4
IC303	B-11	Q304	B-4
IC304	B-11	Q305	B-4
IC305	B-6	Q306	D-5
IC306	B-5	Q351	C-4
IC307	E-9	Q352	C-4
IC308	F-8	Q353	C-4
IC309	F-7	Q354	D-4
IC355	C-6	Q355	D-4
IC356	C-5	Q356	F-7
IC403	C-6	Q403	D-7
IC404	C-10	Q404	D-7
IC405	C-9	Q406	D-6
IC406	B-10	Q407	D-5
IC407	C-8	Q408	D-5
IC408	C-7	Q409	D-5
IC409	D-8	Q411	F-4
IC410	B-8	Q412	F-4
IC411	D-7	Q413	F-3
IC412	F-10	Q722	B-2
IC417	E-13	Q772	B-2
IC418	E-4		
IC419	E-5		
IC420	E-6		
IC421	F-4		
IC710	C-2		

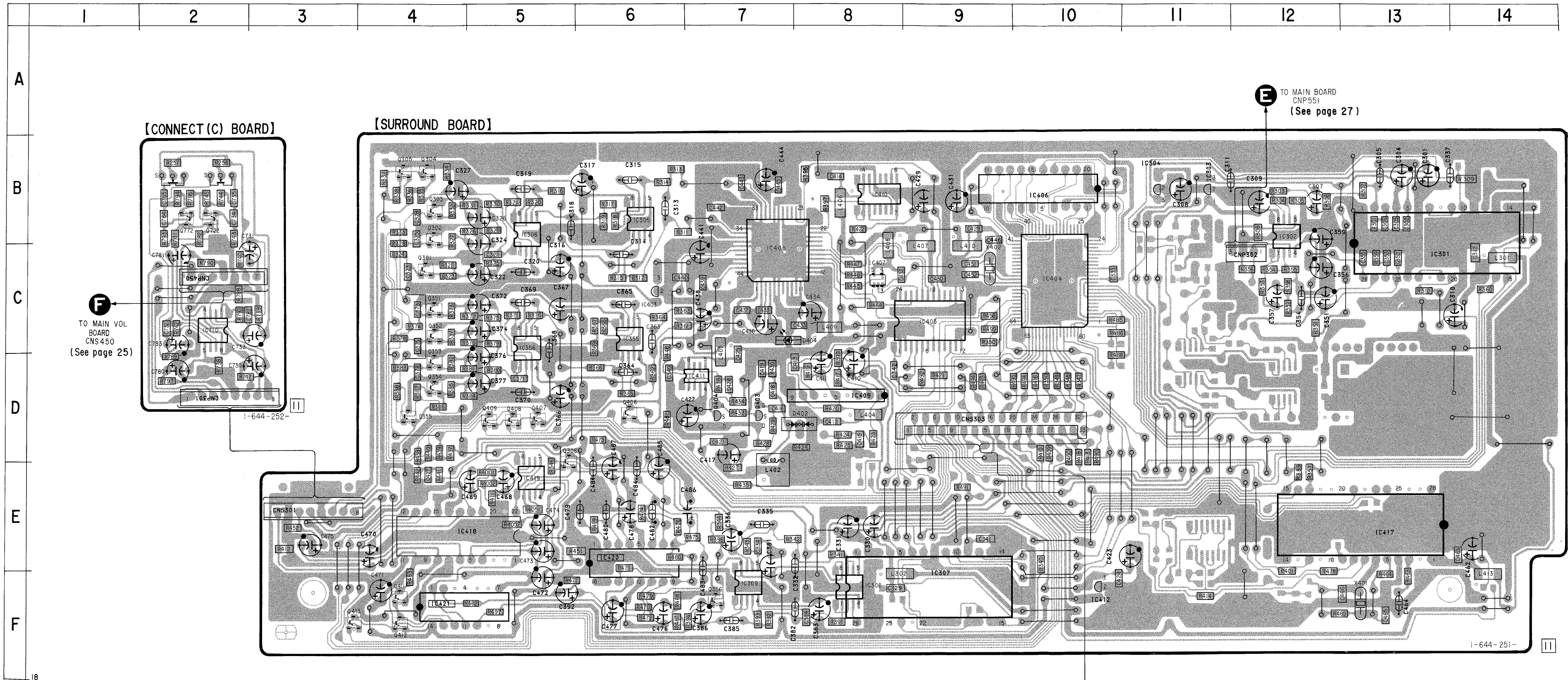

F TO MAIN VOL BOARD CNS 450 (See page 25)

E TO MAIN BOARD CNP 551 (See page 27)

C TO MAIN BOARD CNS 351 (See page 27)

Note:
 ● ○ : parts extracted from the component side.
 ● ○ : parts extracted from the conductor side.
 ● ■ : parts mounted on the conductor side.

4-9. PRINTED WIRING BOARDS —DISPLAY Section— • See page 13 for Circuit Boards Location and Semiconductor Lead Layouts.

● Semiconductor Location

Ref. No.	Location	Ref. No.	Location
D202	D-14	IC201	D-4
D203	E-11	IC202	D-6
D204	D-11	IC203	D-9
D205	D-11	IC204	D-3
D209	D-12		
D211	B-2	Q201	E-2
D212	C-14	Q202	E-2
D217	D-9	Q203	B-13
D218	D-9	Q213	B-13
D220	E-9	Q223	B-13
D223	B-5		
D224	B-6		
D225	B-7		
D226	B-9		
D227	B-10		
D228	B-11		
D229	B-12		
D230	B-13		
D231	B-3		
D232	B-4		
D233	B-5		
D234	B-6		
D235	B-7		
D236	B-8		
D237	B-9		
D238	B-10		
D239	B-11		
D240	B-12		
D241	B-3		
D242	B-4		
D243	B-5		
D244	B-6		
D245	B-7		
D246	B-9		
D247	B-10		
D248	B-11		
D249	B-12		
D250	B-13		
D251	D-2		
D252	D-11		

Note:
 ● ○ — : parts extracted from the component side.
 ● — : parts extracted from the conductor side.
 ● ■ : parts mounted on the conductor side.

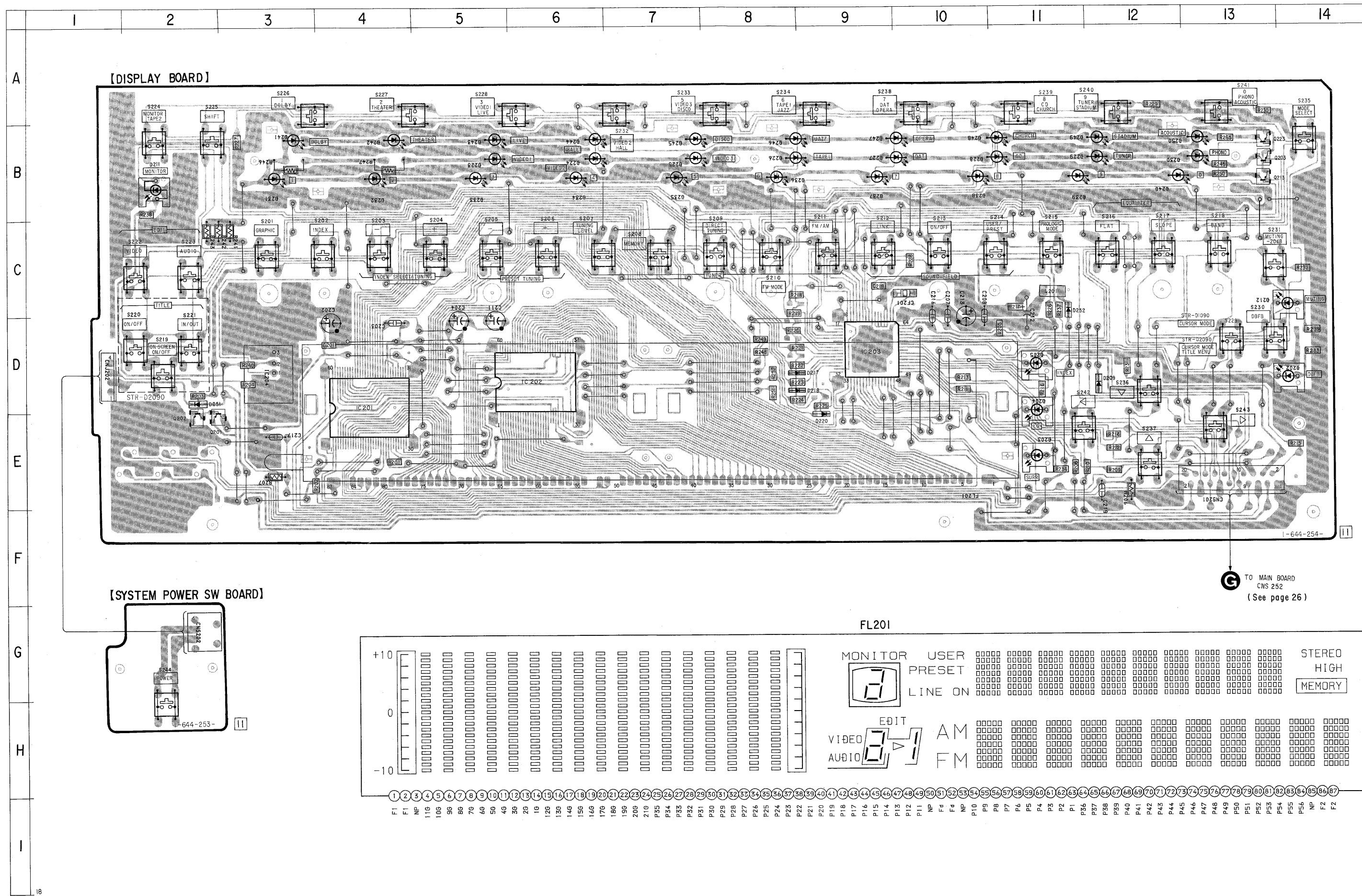

[SYSTEM POWER SW BOARD]

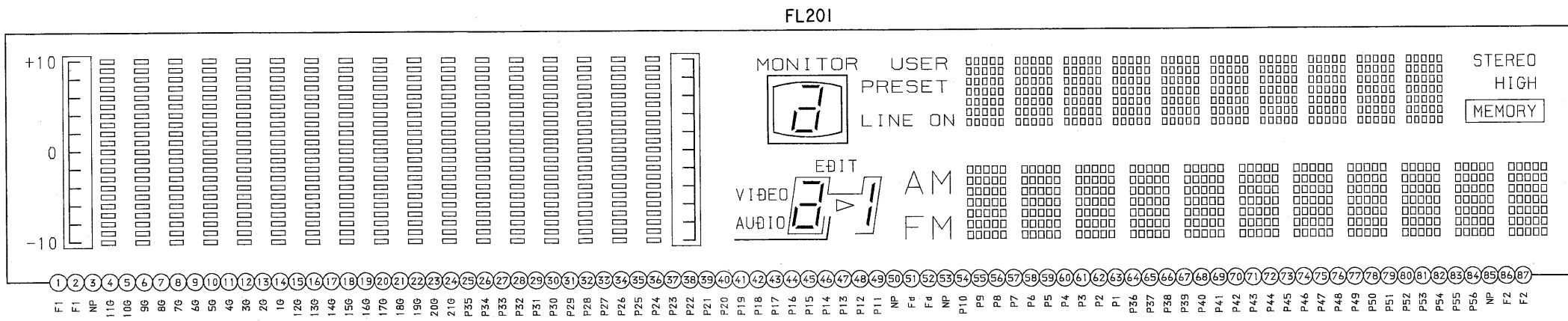
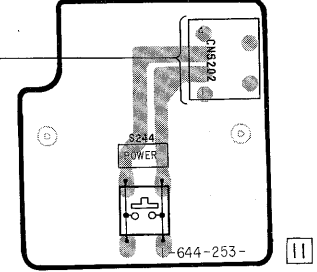

TO MAIN BOARD
 CNS 252
 (See page 26)

4-10. SCHEMATIC DIAGRAMS —DISPLAY Section—

● IC Block Diagram

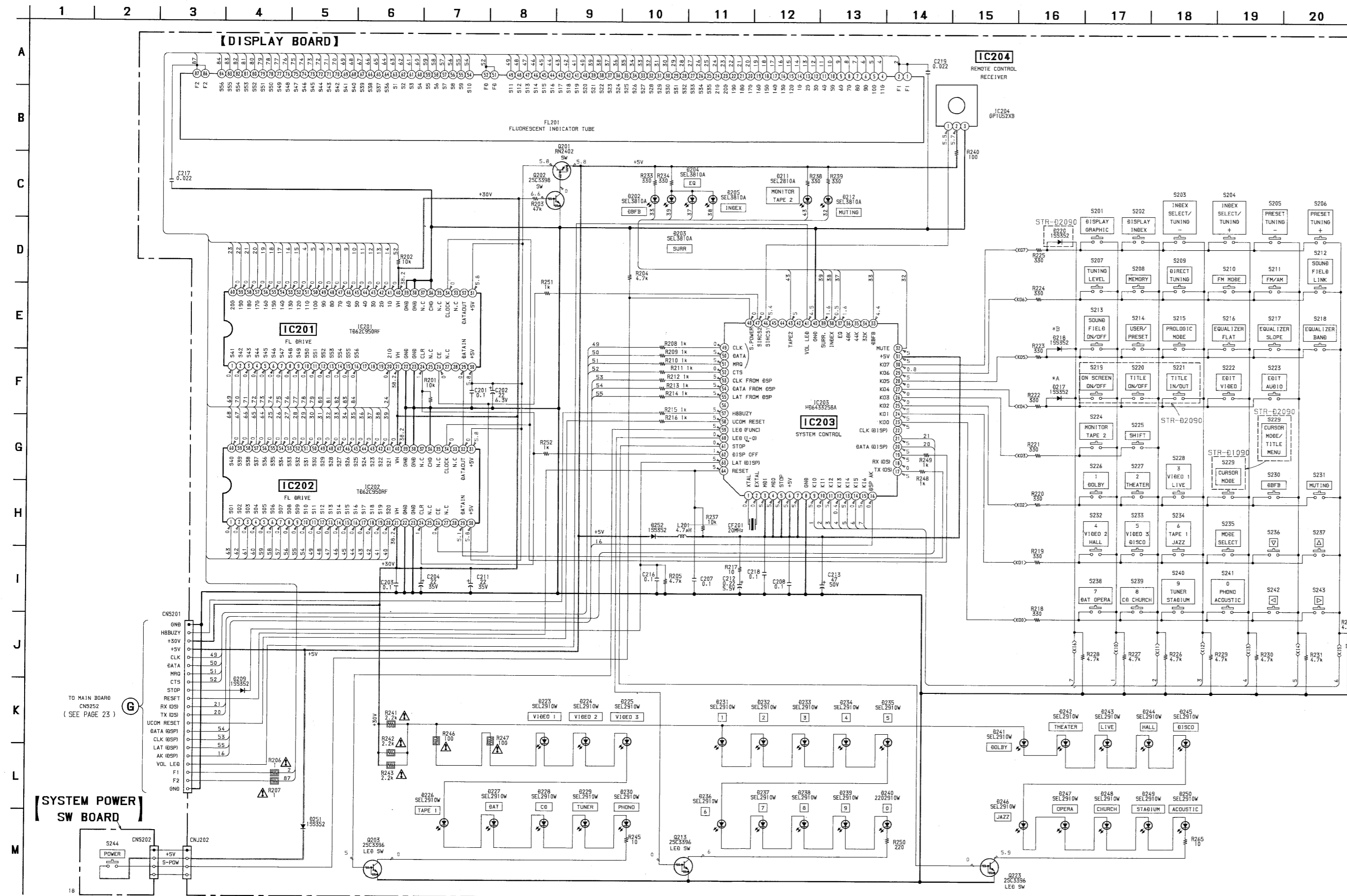

IC201, 202 TD62C950RF

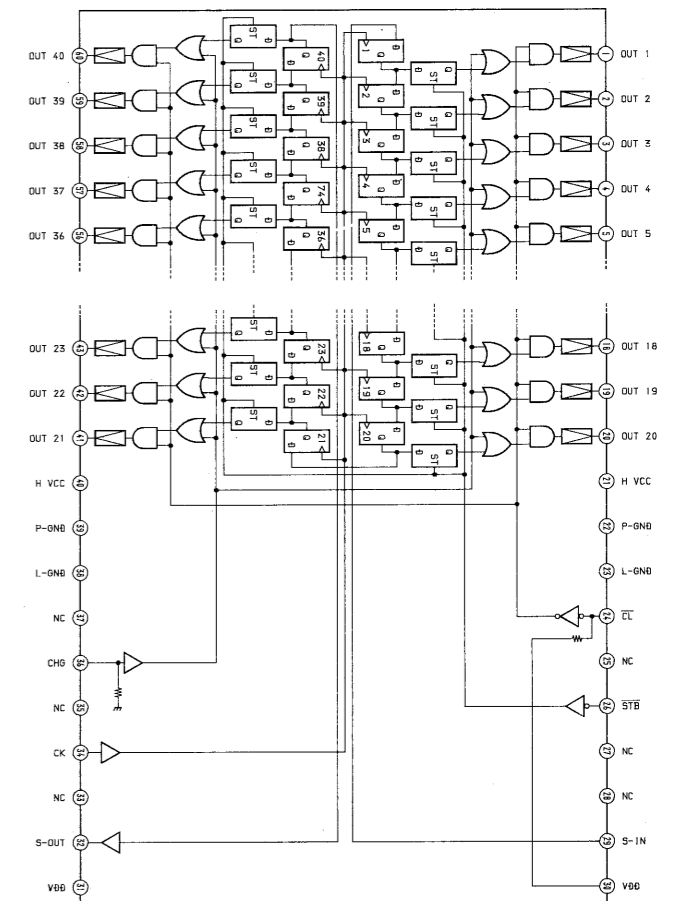

- Note:**
- All capacitors are in μF unless otherwise noted. pF : μF 50WV or less are not indicated except for electrolytics and tantalums.
 - All resistors are in Ω and $1/4\text{W}$ or less unless otherwise specified.
 - : nonflammable resistor.

Note:
The components identified by mark or dotted line with mark are critical for safety. Replace only with part number specified.

Note:
Les composants identifiés par une marque sont critiques pour la sécurité. Ne les remplacer que par une pièce portant le numéro spécifié.

- : B+ Line
- : B- Line
- : adjustment for repair.
- Voltages are dc with respect to ground under no-signal (detuned) conditions.
- Voltages are taken with a VOM (Input Impedance 10M Ω). Voltage variations may be noted due to normal production tolerances.
- See page10 for *A, *B note.

4-12. PRINTED WIRING BOARD —VDP Section— (STR-2090 only)

• See page 13 for Circuit Boards Location and Semiconductor Lead Layouts.

● Semiconductor Location

Ref. No.	Location
IC105	E-2
IC106	E-2
IC107	D-2
IC108	E-3
IC110	B-2
IC111	C-2
IC113	C-3
IC114	D-3
IC115	C-3
IC117	D-4
IC118	E-4
IC119	E-5
IC120	D-6
IC121	E-6
IC123	A-6
IC124	A-5
IC125	B-4
IC126	A-5
IC127	D-3
IC128	C-6
IC129	A-6
IC130	D-5
IC171	C-3
Q112	B-1
Q113	A-1
Q114	A-1
Q115	D-2
Q116	B-2
Q117	B-1
Q118	C-4
Q119	D-2
Q120	A-2

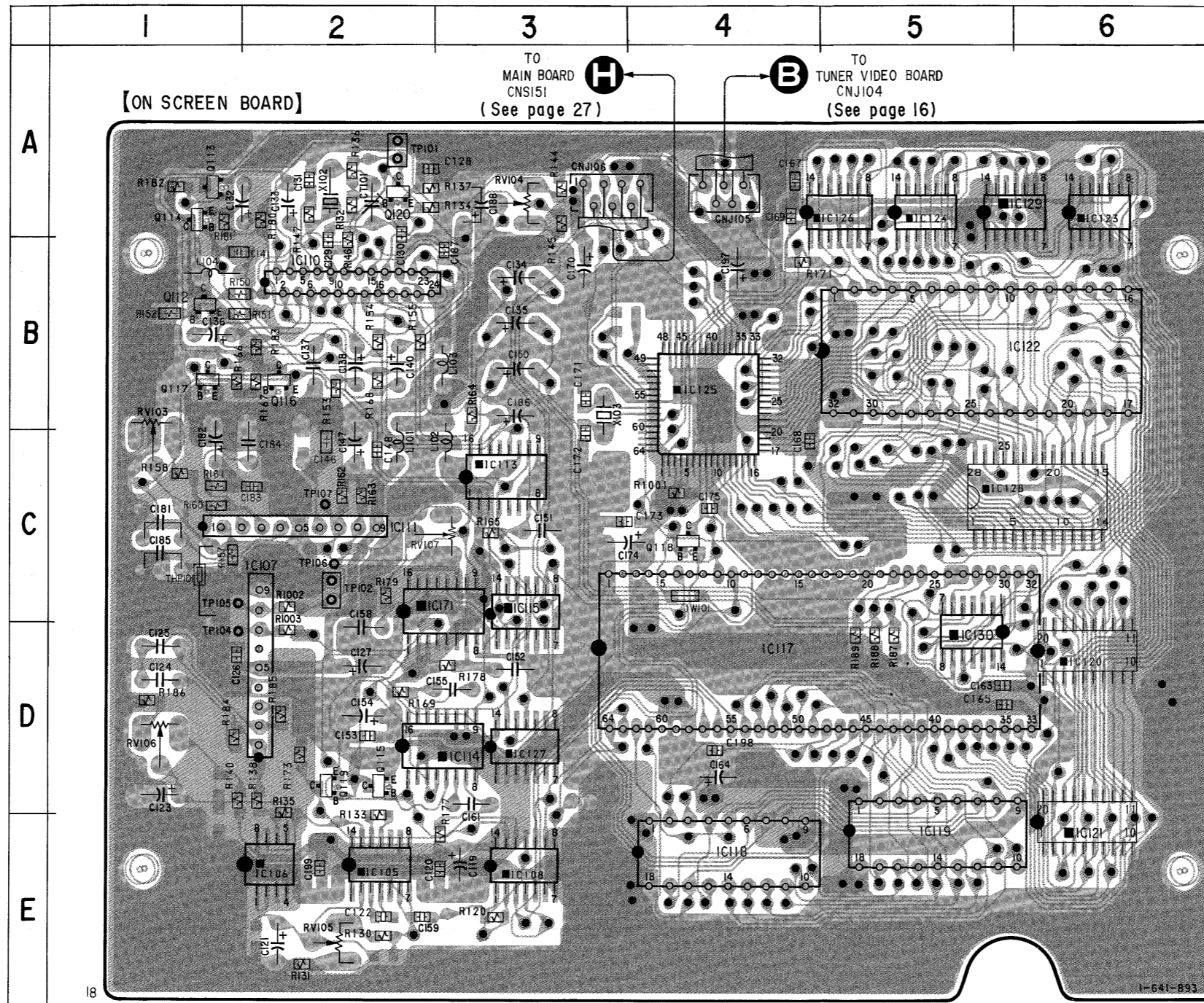

Note:

- : parts extracted from the component side.
- : parts extracted from the conductor side.
- : parts mounted on the conductor side.
- : Through hole
- ▨ : Pattern on the side which is seen.
- ◻ : Pattern of the rear side.

● IC Block Diagrams

IC105 SN74LS628NS

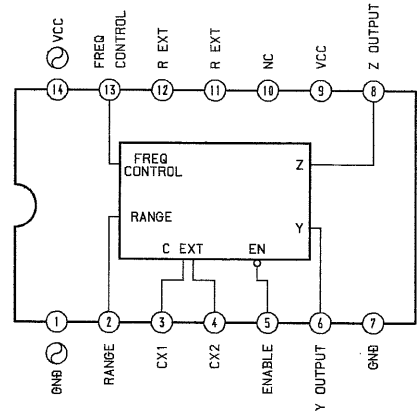

IC107 TC5081AP

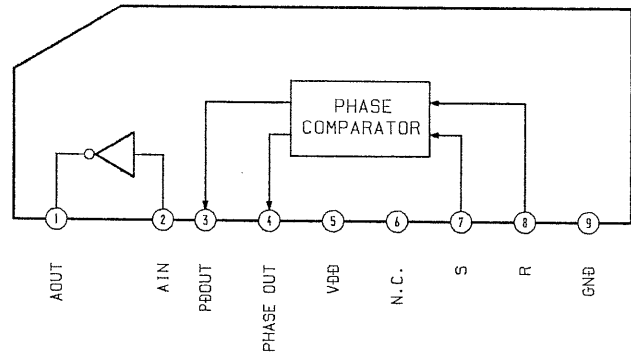

IC110 BA7230LS

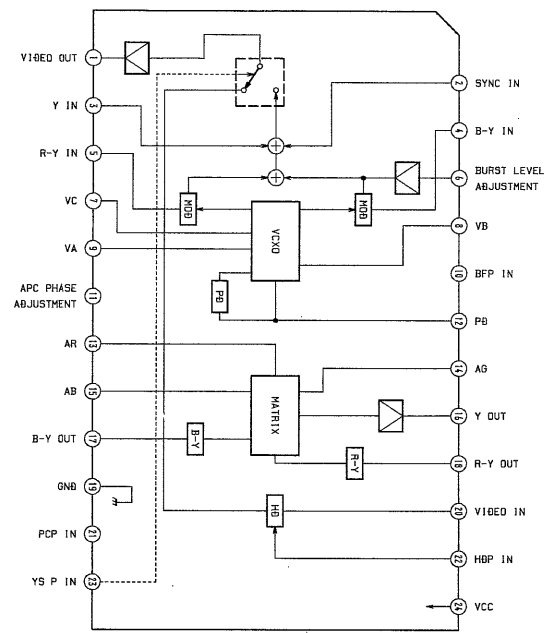

IC111 LVA519S

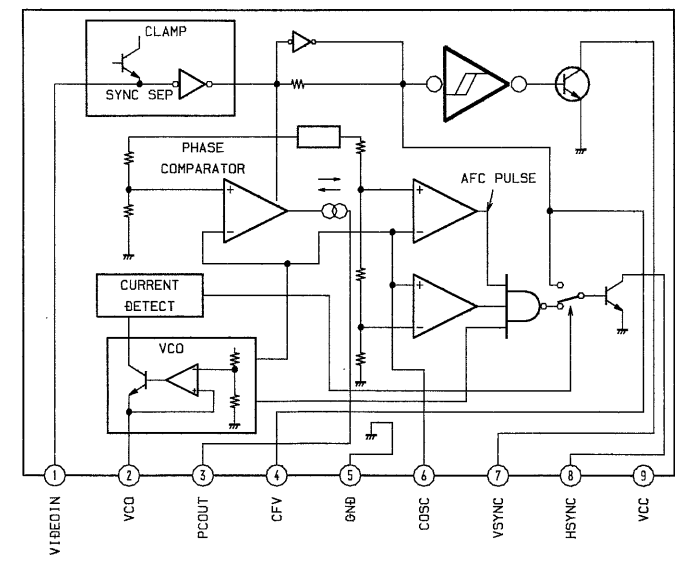

IC117 V9938

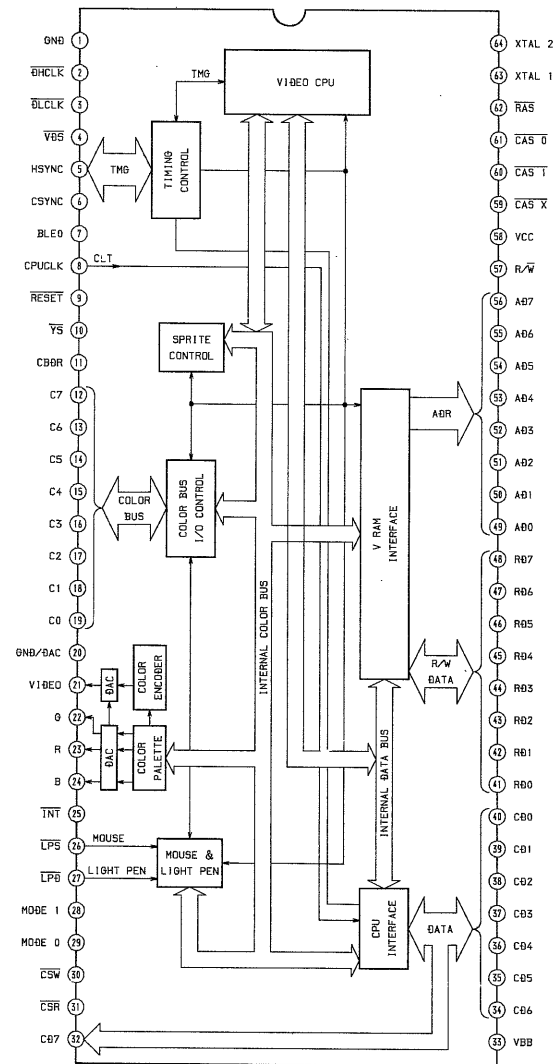

IC118, 119 MB81464-12

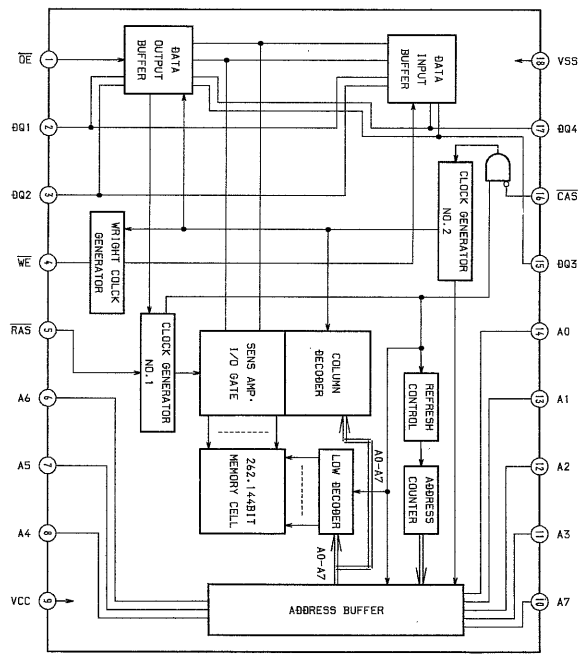

IC120 SN74HC573BNS

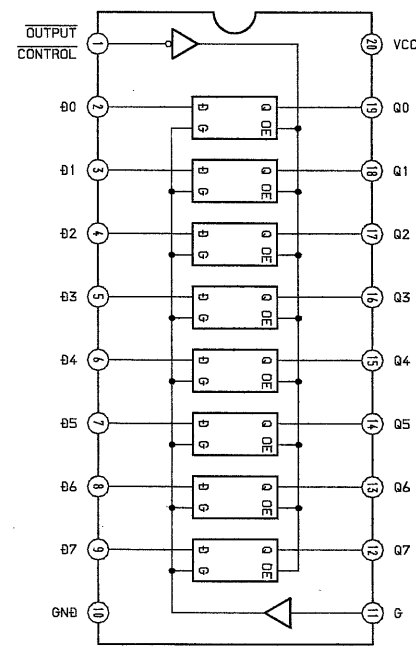

IC121 SN74HC541ANS

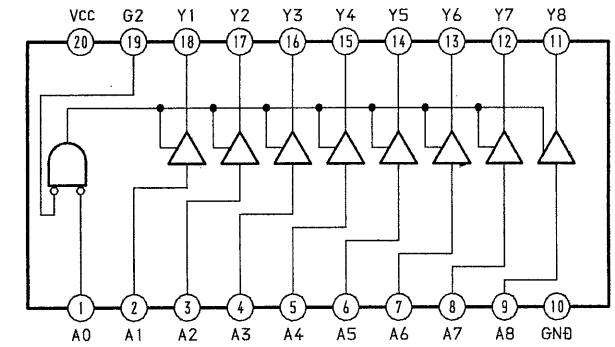

IC122 HN27C101AP12-R001

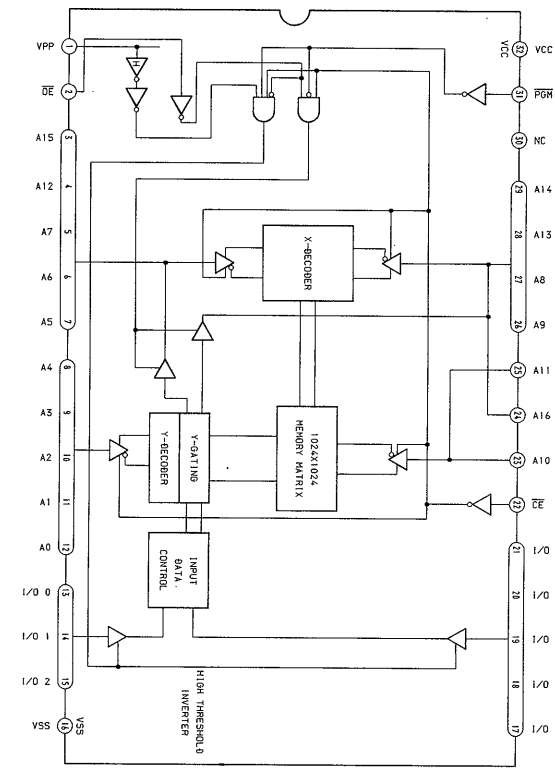

IC125 HD6435208F

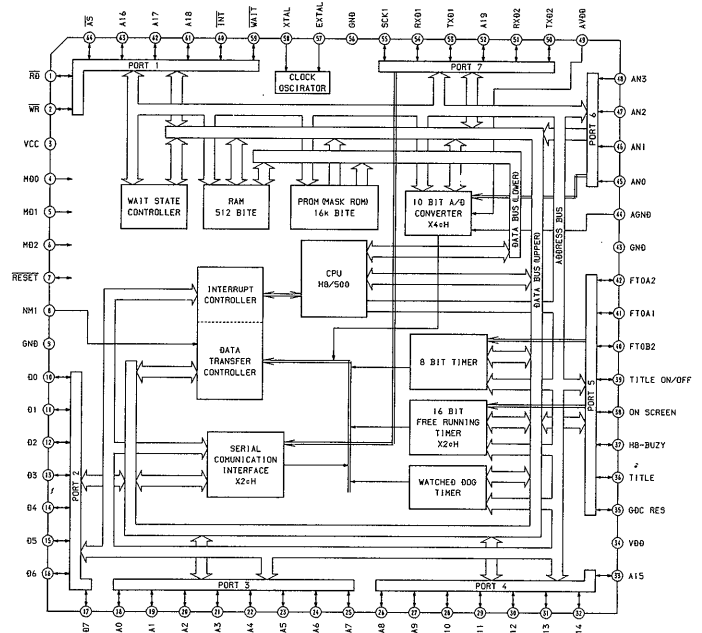

IC128 LC3664RML-12

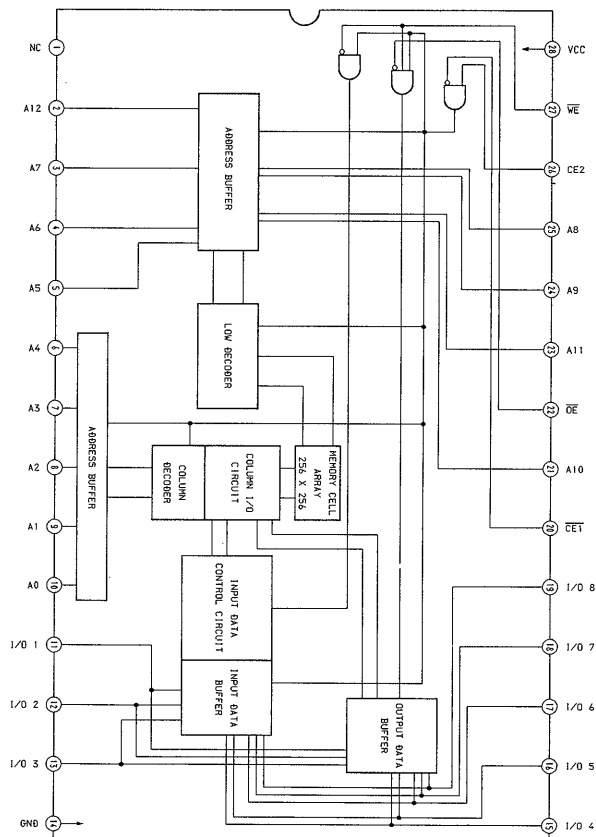

SECTION 5 EXPLODED VIEWS

NOTE:

- XX, -X mean standardized parts, so they may have some differences from the original one.

- Color Indication of Appearance Parts

Example:

KNOB, BALANCE(WHITE)...(RED)

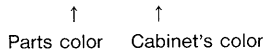

- Items marked " * " are not stocked since they are seldom required for routine service. Some delay should be anticipated when ordering these items.
- The mechanical parts with no reference number in the exploded views are not supplied.
- hardware (#mark) list is given in the last of this parts list.

CND : Canadian

The components identified by mark or dotted line with mark are critical for safety. Replace only with part number specified.

Les composants identifiés par une marque sont critiques pour la sécurité. Ne les remplacer que par une pièce portant le numéro spécifié.

5-1. FRONT PANEL SECTION

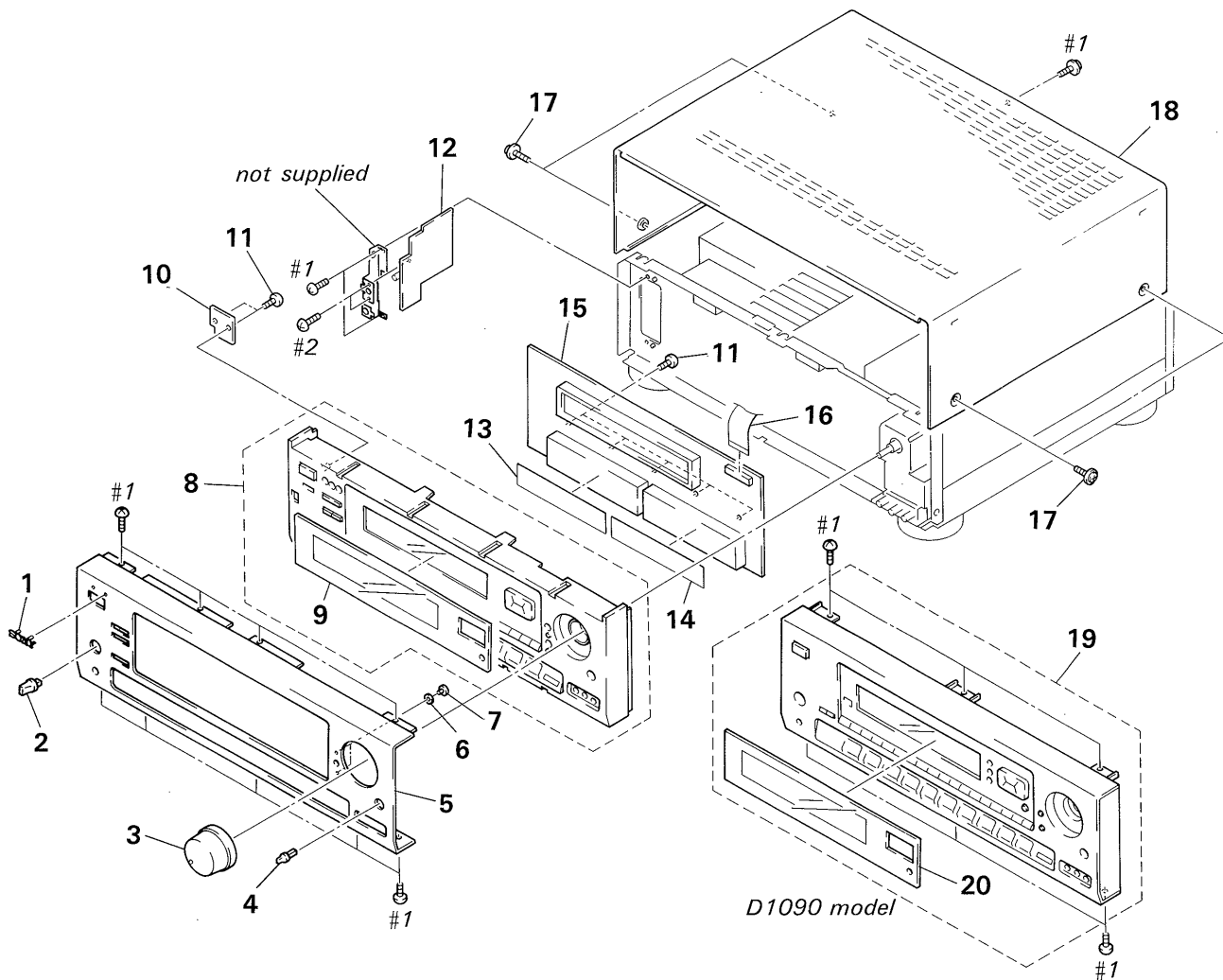



Ref. No.	Part No.	Description	Remark
1	4-908-848-01	EMBLEM, SONY (D2090)	
2	4-908-097-21	KNOB (SPEAKER)	
3	X-4941-650-1	KNOB (A) ASSY (VOLUME) (D2090)	
3	X-4943-036-1	KNOB ASSY (VOLUME) (D1090)	
4	4-925-014-01	KNOB (DIA. 10) (BALANCE)	
5	4-952-498-01	PANEL (F), FRONT (D2090)	
* 6	4-927-881-01	SHEET, ADHESIVE (D2090)	
7	4-938-518-01	INDICATOR (C) (D2090)	
8	X-4942-708-1	PANEL (B) ASSY, FRONT (D2090)	
9	4-952-486-11	PLATE (A), INDICATION (D2090)	
* 10	1-644-253-11	SYSTEM POWER SW BOARD	

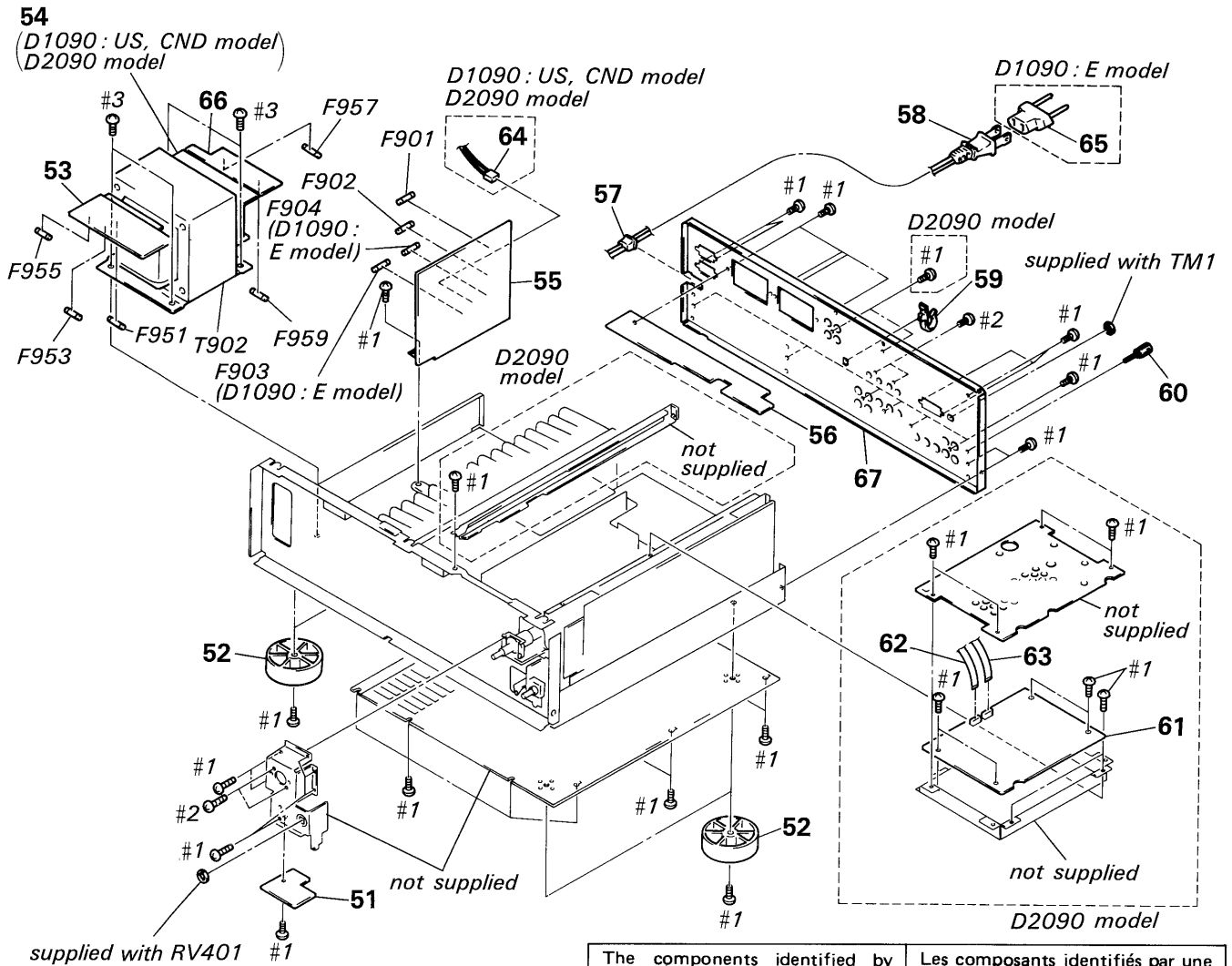

Ref. No.	Part No.	Description	Remark
11	4-951-620-01	SCREW (2. 6X8), +BVTP	
* 12	1-644-263-11	SP SW BOARD	
* 13	4-954-181-01	PLATE (F), INDICATION (1-5)	
* 14	4-954-181-11	PLATE (F), INDICATION (6-10)	
* 15	A-4347-945-A	DISPLAY BOARD, COMPLETE (D2090)	
* 15	A-4347-977-A	DISPLAY BOARD, COMPLETE (D1090)	
16	1-690-091-11	WIRE, FLAT TYPE (21 CORE)	
17	3-704-366-01	SCREW (CASE) (M3X8)	
* 18	4-927-877-11	CASE	
19	X-4942-707-1	PANEL ASSY, FRONT (D1090)	
20	4-952-486-01	PLATE (A), INDICATION (D1090)	















5-2. CHASSIS SECTION



The components identified by mark  or dotted line with mark  are critical for safety. Replace only with part number specified.

Les composants identifiés par une marque  sont critiques pour la sécurité. Ne les remplacer que par une pièce portant le numéro spécifié.

Ref. No.	Part No.	Description	Remark
* 51	1-644-270-11	FRONT VIDEO BOARD	
52	X-4942-706-1	FOOT (58175) ASSY	
* 53	1-644-272-11	TRANS TERMINAL (2) BOARD	
* 54	1-644-273-11	TRANS TERMINAL (3) BOARD	(D1090:US,CND/D2090)
* 55	A-4347-955-A	POWER SUPPLY BOARD, COMPLETE	(D1090:US,CND/D2090)
* 55	A-4347-956-A	POWER SUPPLY BOARD, COMPLETE	(D1090:E)
* 56	1-644-261-11	SP TERMINAL BOARD	
* 57	3-703-244-00	BUSHING (2104), CORD	
 58	1-575-975-11	CORD, POWER (D1090:US,CND/D2090)	
 58	1-590-074-11	CORD, POWER (D1090:E)	
* 59	4-949-235-01	HOOK	
60	4-947-010-01	SCREW, FEEDER FIXED	
* 61	A-4347-944-A	ON SCREEN BOARD, COMPLETE (D2090)	
62	1-575-777-11	WIRE, FLAT TYPE (5 CORE) (D2090)	
63	1-690-421-11	WIRE, FLAT TYPE (7 CORE) (D2090)	
64	1-696-073-21	LEAD (WITH CONNECTOR) (2 CORE)	(D1090:US,CND/D2090)
 65	1-569-007-11	ADAPTER, CONVERSION 2P (D1090:E)	
* 66	1-644-271-12	TRANS TERMINAL (1) BOARD	

Ref. No.	Part No.	Description	Remark
* 67	4-952-499-01	PANEL, BACK (D1090:US)	
* 67	4-952-499-11	PANEL, BACK (D1090:CND)	
* 67	4-952-499-21	PANEL, BACK (D1090:E)	
* 67	4-952-499-31	PANEL, BACK (D2090:US)	
* 67	4-952-499-41	PANEL, BACK (D2090:CND)	
 F901	1-532-350-00	FUSE (4A) (D1090:E)	
 F901	1-576-108-11	FUSE (4A) (D1090:US,CND/D2090)	
 F902	1-532-350-00	FUSE (4A) (D1090:E)	
 F902	1-532-749-11	FUSE, GLASS TUBE (8A)	(D1090:US,CND/D2090)
 F903	1-532-350-00	FUSE (4A) (D1090:E)	
 F904	1-532-350-00	FUSE (4A) (D1090:E)	
 F951	1-532-749-11	FUSE, GLASS TUBE (8A)	
 F953	1-532-749-11	FUSE, GLASS TUBE (8A)	
 F955	1-576-108-11	FUSE (4A)	
 F957	1-576-109-11	FUSE (5A)	
 F959	1-576-109-11	FUSE (5A)	
 T902	1-697-009-11	TRANSFORMER, POWER (D1090:US/D2090:US)	
 T902	1-697-010-11	TRANSFORMER, POWER (D1090:CND/D2090:CND)	
 T902	1-697-011-11	TRANSFORMER, POWER (D1090:E)	

5-3. MAIN BOARD SECTION

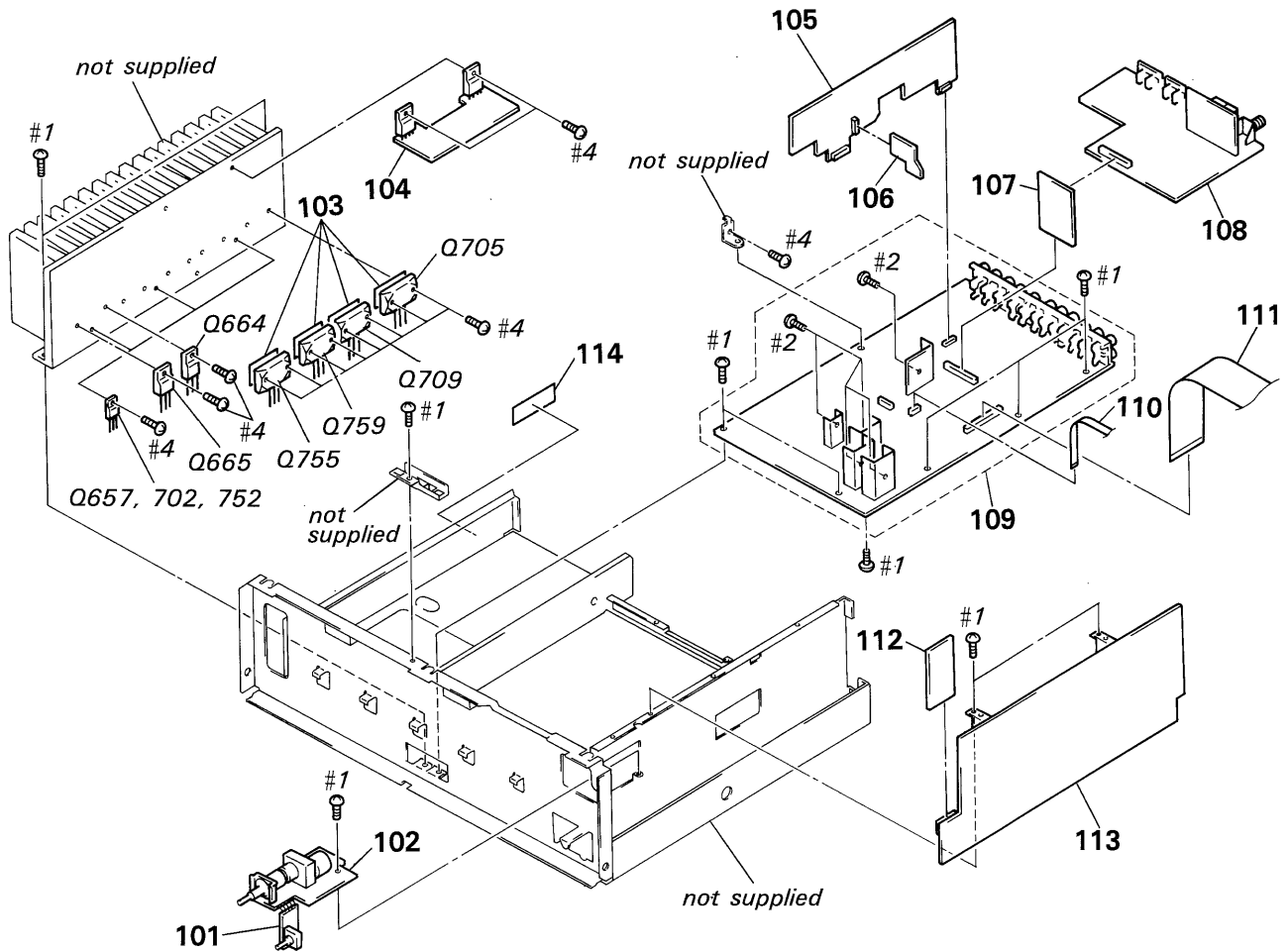

Ref. No.	Part No.	Description	Remark
* 101	1-644-266-11	BALANCE VOL BOARD	
* 102	1-644-265-11	MAIN VOL BOARD	
103	4-885-901-31	SHEET, RADIATION	
* 104	A-4347-960-A	SUB AMP BOARD, COMPLETE	
* 105	A-4347-975-A	A CLASS BOARD, COMPLETE	
* 106	1-644-257-11	CONNECT (A) BOARD	
* 107	1-644-268-11	CONNECT (B) BOARD	
* 108	A-4347-938-A	TUNER VIDEO BOARD, COMPLETE (D2090)	
* 108	A-4347-954-A	TUNER VIDEO BOARD, COMPLETE (D1090)	
* 109	A-4347-940-A	MAIN BOARD, COMPLETE (D2090:US)	
* 109	A-4347-941-A	MAIN BOARD, COMPLETE (D2090:CND)	
* 109	A-4347-974-A	MAIN BOARD, COMPLETE (D1090:CND)	
* 109	A-4356-005-A	MAIN BOARD, COMPLETE (D1090:US, E)	
110	1-575-848-11	WIRE, FLAT TYPE (5 CORE)	

Ref. No.	Part No.	Description	Remark
111	1-696-550-11	WIRE (FLAT TYPE) (33 CORE)	
* 112	A-4356-309-A	CONNECT (C) BOARD, COMPLETE	
* 113	A-4347-979-A	SURROUND BOARD, COMPLETE	
* 114	3-703-044-26	LABEL, CAUTION	
Q657	8-729-209-15	TRANSISTOR 2SD2012	
Q664	8-729-321-24	TRANSISTOR 2SA1672-0Y	
Q665	8-729-321-21	TRANSISTOR 2SC4387-0Y	
Q702	8-729-209-15	TRANSISTOR 2SD2012	
Q705	8-729-320-96	TRANSISTOR 2SC2921-0PY	
Q709	8-729-320-73	TRANSISTOR 2SA1215-0Y	
Q752	8-729-209-15	TRANSISTOR 2SD2012	
Q755	8-729-320-96	TRANSISTOR 2SC2921-0PY	
Q759	8-729-320-73	TRANSISTOR 2SA1215-0Y	

SECTION 6
ELECTRICAL PARTS LIST

A CLASS

BALANCE VOL

NOTE:

- Due to standardization, replacements in the parts list may be different from the parts specified in the diagrams or the components used on the set.
- -XX and -X mean standardized parts, so they may have some difference from the original one.
- RESISTORS
All resistors are in ohms.
METAL: Metal-film resistor.
METAL OXIDE: Metal oxide-film resistor.
F: nonflammable

- Items marked "*" are not stocked since they are seldom required for routine service. Some delay should be anticipated when ordering these items.
- SEMICONDUCTORS
In each case, u: μ , for example:
uA.: μ A. uPA.: μ PA.
uPB.: μ PB. uPC.: μ PC. uPD.: μ PD.
- CAPACITORS
uF: μ F
- COILS
uH: μ H

The components identified by mark Δ or dotted line with mark Δ are critical for safety. Replace only with part number specified.

Les composants identifiés par une marque Δ sont critiques pour la sécurité. Ne les remplacer que par une pièce portant le numéro spécifié.

When indicating parts by reference number, please include the board.

Ref. No.	Part No.	Description	Remark
*	A-4347-975-A	A CLASS BOARD, COMPLETE ***** < CAPACITOR >	
C270	1-136-165-00	FILM 0.1uF 5% 50V	
C271	1-124-907-11	ELECT 10uF 20% 50V	
C701	1-124-927-11	ELECT 4.7uF 20% 100V	
C702	1-164-070-11	CERAMIC 100PF 5% 50V	
C703	1-162-219-31	CERAMIC 68PF 5% 50V	
C704	1-102-316-00	CERAMIC 15PF 5% 500V	
C705	1-102-936-00	CERAMIC 3.0PF +-0.25PF 50V	
C706	1-124-443-00	ELECT 100uF 20% 10V	
C716	1-124-931-11	ELECT 47uF 20% 100V	
C727	1-164-159-11	CERAMIC 0.1uF 50V	
C736	1-164-077-11	CERAMIC 220PF 5% 50V	
C737	1-124-927-11	ELECT 4.7uF 20% 100V	
C751	1-124-927-11	ELECT 4.7uF 20% 100V	
C752	1-164-070-11	CERAMIC 100PF 5% 50V	
C753	1-162-219-31	CERAMIC 68PF 5% 50V	
C754	1-102-316-00	CERAMIC 15PF 5% 500V	
C755	1-102-936-00	CERAMIC 3.0PF +-0.25PF 50V	
C756	1-124-443-00	ELECT 100uF 20% 10V	
C766	1-124-931-11	ELECT 47uF 20% 100V	
C786	1-164-077-11	CERAMIC 220PF 5% 50V	
C787	1-124-927-11	ELECT 4.7uF 20% 100V	
		< CONNECTOR >	
CNP761	1-691-163-11	PIN, CONNECTOR 6P	
* CNP762	1-691-175-11	CONNECTOR (BOARD TO BOARD) 5P	
CNP763	1-691-178-11	CONNECTOR (BOARD TO BOARD) 8P	
CNP764	1-564-507-11	PLUG, CONNECTOR 4P	
		< COIL >	
* L701	1-420-872-00	COIL, AIR CORE	
		< IC >	
IC701	8-749-921-85	IC STK-3122-3	
		< TRANSISTOR >	
Q255	8-729-900-63	TRANSISTOR DTA124ES	

Ref. No.	Part No.	Description	Remark
Q256	8-729-900-63	TRANSISTOR DTA124ES	
Q720	8-729-141-30	TRANSISTOR 2SC3623A-LK	
Q721	8-729-141-30	TRANSISTOR 2SC3623A-LK	
Q770	8-729-141-30	TRANSISTOR 2SC3623A-LK	
Q771	8-729-141-30	TRANSISTOR 2SC3623A-LK	
		< RESISTOR >	
R259	1-249-437-11	CARBON 47K 5% 1/4W	
R260	1-249-437-11	CARBON 47K 5% 1/4W	
R261	1-249-417-11	CARBON 1K 5% 1/4W	
R262	1-249-429-11	CARBON 10K 5% 1/4W	
R263	1-249-429-11	CARBON 10K 5% 1/4W	
R270	1-249-433-11	CARBON 22K 5% 1/4W	
R271	1-249-433-11	CARBON 22K 5% 1/4W	
R701	1-249-417-11	CARBON 1K 5% 1/4W	
R703	1-249-441-11	CARBON 100K 5% 1/4W	
R704	1-249-413-11	CARBON 470 5% 1/4W	
R705	1-249-441-11	CARBON 100K 5% 1/4W	
R706	1-247-828-11	CARBON 750 5% 1/4W	
R741	1-249-405-11	CARBON 100 5% 1/4W	
R742	1-249-441-11	CARBON 100K 5% 1/4W	
R747	1-249-417-11	CARBON 1K 5% 1/4W	
R751	1-249-417-11	CARBON 1K 5% 1/4W	
R753	1-249-441-11	CARBON 100K 5% 1/4W	
R754	1-249-413-11	CARBON 470 5% 1/4W	
R755	1-249-441-11	CARBON 100K 5% 1/4W	
R756	1-247-828-11	CARBON 750 5% 1/4W	
R791	1-249-405-11	CARBON 100 5% 1/4W	
R792	1-249-441-11	CARBON 100K 5% 1/4W	
R797	1-249-417-11	CARBON 1K 5% 1/4W	

*	1-644-266-11	BALANCE VOL BOARD *****	
		< VARIABLE RESISTOR >	
RV401	1-241-963-11	RES, VAR, CARBON 100K/100K (BALANCE)	

CONNECT (A)

CONNECT (B)

CONNECT (C)

DISPLAY

Ref. No.	Part No.	Description	Remark
*	1-644-257-11	CONNECT (A) BOARD *****	
		< CONNECTOR >	
* CNS751	1-691-176-11	CONNECTOR (BOARD TO BOARD) 6P	
* CNS761	1-691-176-11	CONNECTOR (BOARD TO BOARD) 6P	

*	1-644-268-11	CONNECT (B) BOARD *****	
		< CONNECTOR >	
CNP1	1-691-170-11	PIN, CONNECTOR 13P	
		< CONNECTOR >	
* CNS154	1-691-183-11	CONNECTOR (BOARD TO BOARD) 13P	

*	A-4356-309-A	CONNECT(C) BOARD, COMPLETE *****	
		< CAPACITOR >	
C730	1-124-927-11	ELECT 4.7uF 20% 100V	
C731	1-124-927-11	ELECT 4.7uF 20% 100V	
C732	1-163-109-00	CERAMIC CHIP 47PF 5% 50V	
C733	1-124-927-11	ELECT 4.7uF 20% 100V	
C734	1-163-989-11	CERAMIC CHIP 0.033uF 10% 25V	
C735	1-164-336-11	CERAMIC CHIP 0.33uF 25V	
C780	1-124-927-11	ELECT 4.7uF 20% 100V	
C781	1-124-927-11	ELECT 4.7uF 20% 100V	
C782	1-163-109-00	CERAMIC CHIP 47PF 5% 50V	
C783	1-124-927-11	ELECT 4.7uF 20% 100V	
C784	1-163-989-11	CERAMIC CHIP 0.033uF 10% 25V	
C785	1-164-336-11	CERAMIC CHIP 0.33uF 25V	
		< CONNECTOR >	
CNP301	1-573-146-11	PLUG, CONNECTOR 8P	
CNP450	1-691-164-11	PIN, CONNECTOR 7P	
		< IC >	
IC710	8-759-636-55	IC M5218AFP	
		< TRANSISTOR >	
Q258	8-729-201-56	TRANSISTOR 2SK246-GR2	
Q259	8-729-201-56	TRANSISTOR 2SK246-GR2	
Q722	8-729-802-80	TRANSISTOR 2SC3661	
Q772	8-729-802-80	TRANSISTOR 2SC3661	

Ref. No.	Part No.	Description	Remark
		< RESISTOR >	
R256	1-216-097-00	METAL CHIP 100K 5% 1/10W	
R257	1-216-097-00	METAL CHIP 100K 5% 1/10W	
R738	1-216-097-00	METAL CHIP 100K 5% 1/10W	
R739	1-216-113-00	METAL CHIP 470K 5% 1/10W	
R740	1-216-049-00	METAL CHIP 1K 5% 1/10W	
R742	1-216-073-00	METAL CHIP 10K 5% 1/10W	
R743	1-216-101-00	METAL CHIP 150K 5% 1/10W	
R744	1-216-061-00	METAL CHIP 3.3K 5% 1/10W	
R745	1-216-069-00	METAL CHIP 6.8K 5% 1/10W	
R747	1-216-049-00	METAL CHIP 1K 5% 1/10W	
R781	1-216-039-00	METAL CHIP 390 5% 1/10W	
R782	1-216-017-00	METAL CHIP 47 5% 1/10W	
R788	1-216-097-00	METAL CHIP 100K 5% 1/10W	
R789	1-216-113-00	METAL CHIP 470K 5% 1/10W	
R790	1-216-049-00	METAL CHIP 1K 5% 1/10W	
R792	1-216-073-00	METAL CHIP 10K 5% 1/10W	
R793	1-216-101-00	METAL CHIP 150K 5% 1/10W	
R794	1-216-061-00	METAL CHIP 3.3K 5% 1/10W	
R795	1-216-069-00	METAL CHIP 6.8K 5% 1/10W	
R797	1-216-049-00	METAL CHIP 1K 5% 1/10W	

*	A-4347-977-A	DISPLAY BOARD, COMPLETE (D1090)	
*	A-4347-945-A	DISPLAY BOARD, COMPLETE (D2090) *****	
*	4-952-472-01	HOLDER (S), FL TUBE	
*	4-952-473-01	HOLDER (S), LED	
		< CAPACITOR >	
C201	1-164-004-11	CERAMIC CHIP 0.1uF 10% 25V	
C202	1-124-638-11	ELECT 22uF 20% 10V	
C203	1-136-165-00	FILM 0.1uF 5% 50V	
C204	1-124-916-11	ELECT 22uF 20% 63V	
C207	1-136-165-00	FILM 0.1uF 5% 50V	
C208	1-136-165-00	FILM 0.1uF 5% 50V	
C211	1-126-233-11	ELECT 22uF 20% 50V	
C212	1-125-486-11	DOUBLE LAYERS 0.22F 5.5V	
C213	1-124-910-11	ELECT 47uF 20% 50V	
C216	1-136-165-00	FILM 0.1uF 5% 50V	
C217	1-164-097-11	CERAMIC 0.022uF 50V	
C218	1-164-004-11	CERAMIC CHIP 0.1uF 10% 25V	
C219	1-164-097-11	CERAMIC 0.022uF 50V	
		< FILTER >	
CF201	1-567-849-11	OSCILLATOR, CERAMIC 20MHz	

DISPLAY

Ref.No.	Part No.	Description	Remark
		< JACK >	
* CNJ202	1-565-480-11	CONNECTOR, BOARD TO BOARD 4P	
		< CONNECTOR >	
CNS201	1-695-382-11	PIN, CONNECTOR (PC BOARD) 21P (D1090)	
* CNS201	1-568-864-11	SOCKET, CONNECTOR 21P (D2090)	
		< DIODE >	
D202	8-719-313-72	LED SEL3810A-CD (DBFB)	
D203	8-719-313-72	LED SEL3810A-CD (SURRE)	
D204	8-719-313-72	LED SEL3810A-CD (EQ)	
D205	8-719-313-72	LED SEL3810A-CD (INDEX)	
D209	8-719-016-74	DIODE 1SS352	
D211	8-719-313-45	LED SEL2810A (MONITOR)	
D212	8-719-313-72	LED SEL3810A-CD (MUTING)	
D217	8-719-016-74	DIODE 1SS352	
D218	8-719-016-74	DIODE 1SS352	
D220	8-719-016-74	DIODE 1SS352 (D2090)	
D223	8-719-302-68	LED SEL2910W-D (VIDEO1)	
D224	8-719-302-68	LED SEL2910W-D (VIDEO3)	
D225	8-719-302-68	LED SEL2910W-D (TAPE1)	
D226	8-719-302-68	LED SEL2910W-D (DAT)	
D227	8-719-302-68	LED SEL2910W-D (CD)	
D228	8-719-302-68	LED SEL2910W-D (TUNER)	
D229	8-719-302-68	LED SEL2910W-D (TUNER)	
D230	8-719-302-68	LED SEL2910W-D (PHONO)	
D231	8-719-302-68	LED SEL2910W-D (1)	
D232	8-719-302-68	LED SEL2910W-D (2)	
D233	8-719-302-68	LED SEL2910W-D (3)	
D234	8-719-302-68	LED SEL2910W-D (4)	
D235	8-719-302-68	LED SEL2910W-D (5)	
D236	8-719-302-68	LED SEL2910W-D (6)	
D237	8-719-302-68	LED SEL2910W-D (7)	
D238	8-719-302-68	LED SEL2910W-D (8)	
D239	8-719-302-68	LED SEL2910W-D (9)	
D240	8-719-302-68	LED SEL2910W-D (0)	
D241	8-719-302-68	LED SEL2910W-D (DOLBY)	
D242	8-719-302-68	LED SEL2910W-D (THEATER)	
D243	8-719-302-68	LED SEL2910W-D (LIVE)	
D244	8-719-302-68	LED SEL2910W-D (HALL)	
D245	8-719-302-68	LED SEL2910W-D (DISCO)	
D246	8-719-302-68	LED SEL2910W-D (JAZZ)	
D247	8-719-302-68	LED SEL2910W-D (OPERA)	
D248	8-719-302-68	LED SEL2910W-D (CHURCH)	
D249	8-719-302-68	LED SEL2910W-D (STADIUM)	
D250	8-719-302-68	LED SEL2910W-D (ACOUSTIC)	
D251	8-719-016-74	DIODE 1SS352	
D252	8-719-016-74	DIODE 1SS352	

Ref.No.	Part No.	Description	Remark
		< FILTER >	
FL201	1-519-724-11	INDICATOR TUBE, FLUORESCENT	
		< IC >	
IC201	8-759-075-35	IC TD62C950RF	
IC202	8-759-075-35	IC TD62C950RF	
IC203	8-759-087-62	IC HD6433258A	
IC204	8-749-920-83	IC GP1U52XB	
		< COIL >	
L201	1-410-377-31	INDUCTOR CHIP 4.7uH	
		< TRANSISTOR >	
Q201	8-729-207-68	TRANSISTOR RN2402	
Q202	8-729-805-41	TRANSISTOR 2SC3398	
Q203	8-729-805-43	TRANSISTOR 2SC3396	
Q213	8-729-805-43	TRANSISTOR 2SC3396	
Q223	8-729-805-43	TRANSISTOR 2SC3396	
		< RESISTOR >	
R201	1-216-073-00	METAL CHIP 10K 5% 1/10W	
R202	1-216-073-00	METAL CHIP 10K 5% 1/10W	
R203	1-216-089-00	METAL CHIP 47K 5% 1/10W	
R204	1-216-065-00	METAL CHIP 4.7K 5% 1/10W	
R205	1-216-065-00	METAL CHIP 4.7K 5% 1/10W	
△R206	1-249-381-11	CARBON 1 5% 1/4W F	
△R207	1-249-381-11	CARBON 1 5% 1/4W F	
R208	1-216-049-00	METAL CHIP 1K 5% 1/10W	
R209	1-216-049-00	METAL CHIP 1K 5% 1/10W	
R210	1-216-049-00	METAL CHIP 1K 5% 1/10W	
R211	1-216-049-00	METAL CHIP 1K 5% 1/10W	
R212	1-216-049-00	METAL CHIP 1K 5% 1/10W	
R213	1-216-049-00	METAL CHIP 1K 5% 1/10W	
R214	1-216-049-00	METAL CHIP 1K 5% 1/10W	
R215	1-216-049-00	METAL CHIP 1K 5% 1/10W	
R216	1-216-049-00	METAL CHIP 1K 5% 1/10W	
R217	1-216-001-00	METAL CHIP 10 5% 1/10W	
R218	1-216-037-00	METAL CHIP 330 5% 1/10W	
R219	1-216-037-00	METAL CHIP 330 5% 1/10W	
R220	1-216-037-00	METAL CHIP 330 5% 1/10W	
R221	1-216-037-00	METAL CHIP 330 5% 1/10W	
R222	1-216-037-00	METAL CHIP 330 5% 1/10W	
R223	1-216-037-00	METAL CHIP 330 5% 1/10W	
R224	1-216-037-00	METAL CHIP 330 5% 1/10W	
R225	1-216-037-00	METAL CHIP 330 5% 1/10W	
R226	1-216-065-00	METAL CHIP 4.7K 5% 1/10W	
R227	1-216-065-00	METAL CHIP 4.7K 5% 1/10W	
R228	1-216-065-00	METAL CHIP 4.7K 5% 1/10W	

The components identified by mark △ or dotted line with mark △ are critical for safety. Replace only with part number specified.

Les composants identifiés par une marque △ sont critiques pour la sécurité. Ne les remplacer que par une pièce portant le numéro spécifié.

DISPLAY

FRONT VIDEO

MAIN

Ref. No.	Part No.	Description	Remark
R229	1-216-065-00	METAL CHIP	4.7K 5% 1/10W
R230	1-216-065-00	METAL CHIP	4.7K 5% 1/10W
R231	1-216-065-00	METAL CHIP	4.7K 5% 1/10W
R232	1-216-065-00	METAL CHIP	4.7K 5% 1/10W
R233	1-216-037-00	METAL CHIP	330 5% 1/10W
R234	1-216-037-00	METAL CHIP	330 5% 1/10W
R237	1-216-073-00	METAL CHIP	10K 5% 1/10W
R238	1-216-037-00	METAL CHIP	330 5% 1/10W
R239	1-216-037-00	METAL CHIP	330 5% 1/10W
R240	1-216-025-00	METAL CHIP	100 5% 1/10W
△R241	1-249-421-11	CARBON	2.2K 5% 1/4W F
△R242	1-249-421-11	CARBON	2.2K 5% 1/4W F
△R243	1-249-421-11	CARBON	2.2K 5% 1/4W F
R245	1-216-001-00	METAL CHIP	10 5% 1/10W
△R246	1-249-405-11	CARBON	100 5% 1/4W F
△R247	1-249-405-11	CARBON	100 5% 1/4W F
R248	1-216-049-00	METAL CHIP	1K 5% 1/10W
R249	1-216-049-00	METAL CHIP	1K 5% 1/10W
R250	1-216-033-00	METAL CHIP	220 5% 1/10W
R251	1-216-049-00	METAL CHIP	1K 5% 1/10W
R252	1-216-049-00	METAL CHIP	1K 5% 1/10W
R265	1-216-001-00	METAL CHIP	10 5% 1/10W
< SWITCH >			
S201	1-554-303-21	SWITCH, TACTILE (DISPLAY:GRAPHIC)	
S202	1-554-303-21	SWITCH, TACTILE (DISPLAY:INDEX)	
S203	1-554-303-21	SWITCH, TACTILE (INDEX SELECT/TUNING:-)	
S204	1-554-303-21	SWITCH, TACTILE (INDEX SELECT/TUNING:+)	
S205	1-554-303-21	SWITCH, TACTILE (PRESET TUNING:-)	
S206	1-554-303-21	SWITCH, TACTILE (PRESET TUNING:+)	
S207	1-554-303-21	SWITCH, TACTILE (TUNING LEVEL)	
S208	1-554-303-21	SWITCH, TACTILE (MEMORY)	
S209	1-554-303-21	SWITCH, TACTILE (DIRECT TUNING)	
S210	1-554-303-21	SWITCH, TACTILE (FM MODE)	
S211	1-554-303-21	SWITCH, TACTILE (FM/AM)	
S212	1-554-303-21	SWITCH, TACTILE (SOUND FIELD:LINK)	
S213	1-554-303-21	SWITCH, TACTILE (SOUND FIELD:ON/OFF)	
S214	1-554-303-21	SWITCH, TACTILE (SOUND FIELD:USER/PRESET)	
S215	1-554-303-21	SWITCH, TACTILE (PROLOGIC MODE)	
S216	1-554-303-21	SWITCH, TACTILE (FLAT)	
S217	1-554-303-21	SWITCH, TACTILE (SLOPE)	
S218	1-554-303-21	SWITCH, TACTILE (BAND)	
S219	1-554-303-21	SWITCH, TACTILE (ON SCREEN ON/OFF) (D2090)	
S220	1-554-303-21	SWITCH, TACTILE (TITLE:ON/OFF) (D2090)	
S221	1-554-303-21	SWITCH, TACTILE (TITLE:IN/OUT) (D2090)	
S222	1-554-303-21	SWITCH, TACTILE (EDIT:VIDEO)	
S223	1-554-303-21	SWITCH, TACTILE (EDIT:AUDIO)	
S224	1-554-303-21	SWITCH, TACTILE (TAPE2)	

Ref. No.	Part No.	Description	Remark
S225	1-554-303-21	SWITCH, TACTILE (SHIFT)	
S226	1-554-303-21	SWITCH, TACTILE (1, DOLBY)	
S227	1-554-303-21	SWITCH, TACTILE (2, THEATER)	
S228	1-554-303-21	SWITCH, TACTILE (3, VIDEO1, LIVE)	
S229	1-554-303-21	SWITCH, TACTILE (CURSOL MODE) (D1090)	
S229	1-554-303-21	SWITCH, TACTILE (CURSOL MODE, TITLE MENU) (D2090)	
S230	1-554-303-21	SWITCH, TACTILE (DBFB)	
S231	1-554-303-21	SWITCH, TACTILE (MUTING -20dB)	
S232	1-554-303-21	SWITCH, TACTILE (4, VIDEO2, HALL)	
S233	1-554-303-21	SWITCH, TACTILE (5, VIDEO3, DISCO)	
S234	1-554-303-21	SWITCH, TACTILE (6, TAPE1, JAZZ)	
S235	1-554-303-21	SWITCH, TACTILE (MODE SELECT)	
S236	1-554-303-21	SWITCH, TACTILE (▽)	
S237	1-554-303-21	SWITCH, TACTILE (△)	
S238	1-554-303-21	SWITCH, TACTILE (7, DATA, OPERA)	
S239	1-554-303-21	SWITCH, TACTILE (8, CD, CHURCH)	
S240	1-554-303-21	SWITCH, TACTILE (9, TUNER, STADIUM)	
S241	1-554-303-21	SWITCH, TACTILE (0, PHONO, ACOUSTIC)	
S242	1-554-303-21	SWITCH, TACTILE (<4)	
S243	1-554-303-21	SWITCH, TACTILE (>)	

*	1-644-270-11	FRONT VIDEO BOARD	

< CONNECTOR >			
* CNS153	1-565-482-11	CONNECTOR, BOARD TO BOARD 6P	
< JACK >			
J131	1-580-174-31	JACK, PIN (3P FRONT) (VIDEO3 INPUT)	
< RESISTOR >			
R129	1-247-804-11	CARBON	75 5% 1/4W

*	A-4356-005-A	MAIN BOARD, COMPLETE (D1090:US, E)	
*	A-4347-974-A	MAIN BOARD, COMPLETE (D1090:CND)	
*	A-4347-940-A	MAIN BOARD, COMPLETE (D2090:US)	
*	A-4347-941-A	MAIN BOARD, COMPLETE (D2090:CND)	

	7-682-547-04	SCREW +BVTT	3X6 (S)
*	4-904-446-01	PLATE, GROUND	
*	4-942-204-01	PLATE, GROUND	
*	4-880-403-11	HEAT SINK	
*	3-309-144-21	HEAT SINK	
*	4-931-903-01	HEAT SINK (DI)	

The components identified by mark △ or dotted line with mark △ are critical for safety. Replace only with part number specified.	Les composants identifiés par une marque △ sont critiques pour la sécurité. Ne les remplacer que par une pièce portant le numéro spécifié.
--	--

MAIN

Ref. No.	Part No.	Description	Remark			Ref. No.	Part No.	Description	Remark		
< CAPACITOR >											
C251	1-124-925-11	ELECT	2.2uF	20%	100V	C715	1-124-472-11	ELECT	470uF	20%	10V
C252	1-164-159-11	CERAMIC	0.1uF		50V	C757	1-124-477-11	ELECT	47uF	20%	25V
C253	1-124-464-11	ELECT	0.22uF	20%	50V	C758	1-102-233-00	CERAMIC	33PF	10%	500V
C501	1-162-282-31	CERAMIC	100PF	10%	50V	C759	1-102-233-00	CERAMIC	33PF	10%	500V
C502	1-124-927-11	ELECT	4.7uF	20%	100V	C760	1-136-165-00	FILM	0.1uF	5%	50V
C503	1-124-477-11	ELECT	47uF	20%	25V	C761	1-136-165-00	FILM	0.1uF	5%	50V
C504	1-130-480-00	MYLAR	0.0056uF	5%	50V	C762	1-136-157-00	FILM	0.022uF	5%	50V (US, E)
C505	1-106-347-00	MYLAR	1500PF	5%	200V	C762	1-136-161-00	FILM	0.047uF	5%	50V (CND)
C506	1-124-927-11	ELECT	4.7uF	20%	100V	C763	1-136-161-00	FILM	0.047uF	5%	50V (CND)
C507	1-126-233-11	ELECT	22uF	20%	50V	C962	1-124-907-11	ELECT	10uF	20%	50V
C513	1-162-294-11	CERAMIC	0.001uF	10%	50V	C963	1-126-955-11	ELECT	4700uF	20%	35V
C515	1-162-294-31	CERAMIC	0.001uF	10%	50V	C964	1-124-910-11	ELECT	47uF	20%	50V
C516	1-162-294-31	CERAMIC	0.001uF	10%	50V	C965	1-126-955-11	ELECT	4700uF	20%	35V
C517	1-124-907-11	ELECT	10uF	20%	50V	C966	1-124-477-11	ELECT	47uF	20%	25V
C518	1-124-907-11	ELECT	10uF	20%	50V	C967	1-124-477-11	ELECT	47uF	20%	25V
C526	1-164-159-11	CERAMIC	0.1uF		50V	C968	1-124-898-11	ELECT	4700uF	20%	16V(D1090)
C551	1-162-282-31	CERAMIC	100PF	10%	50V	C968	1-126-017-11	ELECT	6800uF	20%	16V(D2090)
C552	1-124-927-11	ELECT	4.7uF	20%	100V	C969	1-124-477-11	ELECT	47uF	20%	25V
C553	1-124-477-11	ELECT	47uF	20%	25V	C971	1-124-667-11	ELECT	10uF	20%	100V
C554	1-130-480-00	MYLAR	0.0056uF	5%	50V	C980	1-106-391-12	MYLAR	0.1uF	5%	200V
C555	1-106-347-00	MYLAR	1500PF	5%	200V	C981	1-106-391-12	MYLAR	0.1uF	5%	200V
C556	1-124-927-11	ELECT	4.7uF	20%	100V	C982	1-125-752-11	ELECT	12000uF	20%	71V
C557	1-126-233-11	ELECT	22uF	20%	50V	C983	1-125-752-11	ELECT	12000uF	20%	71V
C590	1-124-927-11	ELECT	4.7uF	20%	100V	C991	1-164-096-11	CERAMIC	0.01uF		50V
C651	1-124-907-11	ELECT	10uF	20%	50V	C992	1-164-096-11	CERAMIC	0.01uF		50V
C652	1-164-083-11	CERAMIC	680PF	10%	50V	C993	1-164-096-11	CERAMIC	0.01uF		50V
C653	1-124-126-00	ELECT	47uF	20%	10V	C994	1-164-096-11	CERAMIC	0.01uF		50V
C654	1-161-959-00	CERAMIC	22PF	10%	500V	< FILTER >					
C655	1-124-126-00	ELECT	47uF	20%	10V	CF251	1-567-849-11	OSCILLATOR, CERAMIC	20MHz		
C656	1-164-014-11	CERAMIC	5PF	0.25PF	50V	< CONNECTOR >					
C657	1-161-959-00	CERAMIC	22PF	10%	500V	* CNP153	1-560-330-00	CONNECTOR PIN	(L)		
C658	1-124-126-00	ELECT	47uF	20%	10V	CNP154	1-691-170-11	PIN, CONNECTOR	13P		
C659	1-136-157-00	FILM	0.022uF	5%	50V (US, E)	* CNP251	1-691-767-11	PLUG, CONNECTOR	5P		
C659	1-136-161-00	FILM	0.047uF	5%	50V (CND)	* CNP253	1-564-506-11	PLUG, CONNECTOR	3P		
C660	1-136-161-00	FILM	0.047uF	5%	50V (CND)	* CNP551	1-564-506-11	PLUG, CONNECTOR	3P		
C661	1-136-165-00	FILM	0.1uF	5%	50V	* CNP554	1-564-506-11	PLUG, CONNECTOR	3P		
C663	1-164-077-11	CERAMIC	220PF	10%	50V	* CNP651	1-564-506-11	PLUG, CONNECTOR	3P		
C680	1-124-931-11	ELECT	47uF	20%	100V	* CNP652	1-564-104-00	PIN, CONNECTOR	(B3P-VH) 3P		
C707	1-124-477-11	ELECT	47uF	20%	25V	* CNP653	1-564-508-11	PLUG, CONNECTOR	5P		
C708	1-102-233-00	CERAMIC	33PF	10%	500V	* CNP654	1-564-507-11	PLUG, CONNECTOR	4P		
C709	1-102-233-00	CERAMIC	33PF	10%	500V	CNP751	1-691-163-11	PIN, CONNECTOR	6P		
C710	1-136-165-00	FILM	0.1uF	5%	50V	CNP752	1-691-162-11	PIN, CONNECTOR	5P		
C711	1-136-165-00	FILM	0.1uF	5%	50V	CNP753	1-691-165-11	PIN, CONNECTOR	8P		
C712	1-136-157-00	FILM	0.022uF	5%	50V (US, E)	* CNP754	1-564-242-00	PIN, CONNECTOR	5P		
C712	1-136-161-00	FILM	0.047uF	5%	50V (CND)	* CNP951	1-564-104-00	PIN, CONNECTOR	(B3P-VH) 3P		
C713	1-136-161-00	FILM	0.047uF	5%	50V (CND)	* CNP953	1-564-242-00	PIN, CONNECTOR	5P		
C714	1-124-925-11	ELECT	2.2uF	20%	100V						

MAIN

Ref. No.	Part No.	Description	Remark
		< CONNECTOR >	
* CNS151	1-568-826-11	SOCKET, CONNECTOR 7P (D2090)	
CNS252	1-568-838-11	PIN, CONNECTOR (PC BOARD) 21P	
* CNS253	1-568-824-11	SOCKET, CONNECTOR 5P	
CNS351	1-695-218-11	SOCKET, CONNECTOR 33P	
		< DIODE >	
D252	8-719-987-63	DIODE 1N4148M	
D253	8-719-987-63	DIODE 1N4148M (D2090)	
D501	8-719-987-63	DIODE 1N4148M	
D610	8-719-987-63	DIODE 1N4148M	
D611	8-719-987-63	DIODE 1N4148M	
D623	8-719-987-63	DIODE 1N4148M	
D651	8-719-933-35	DIODE HZS6A3L	
D652	8-719-987-63	DIODE 1N4148M	
D654	8-719-987-63	DIODE 1N4148M	
D701	8-719-987-63	DIODE 1N4148M	
D702	8-719-985-35	DIODE HZS2ALL	
D703	8-719-985-35	DIODE HZS2ALL	
D704	8-719-987-63	DIODE 1N4148M	
D705	8-719-987-63	DIODE 1N4148M	
D715	8-719-987-63	DIODE 1N4148M	
D716	8-719-987-63	DIODE 1N4148M	
D718	8-719-987-63	DIODE 1N4148M	
D719	8-719-987-63	DIODE 1N4148M	
D720	8-719-987-63	DIODE 1N4148M	
D723	8-719-987-63	DIODE 1N4148M	
D730	8-719-987-63	DIODE 1N4148M	
D731	8-719-987-63	DIODE 1N4148M	
D751	8-719-987-63	DIODE 1N4148M	
D752	8-719-985-35	DIODE HZS2ALL	
D753	8-719-985-35	DIODE HZS2ALL	
D754	8-719-987-63	DIODE 1N4148M	
D765	8-719-987-63	DIODE 1N4148M	
D766	8-719-987-63	DIODE 1N4148M	
D963	8-719-002-76	DIODE UZL-36H	
D970	8-719-312-09	DIODE RBA-402	
D971	8-719-312-09	DIODE RBA-402	
D973	8-719-987-63	DIODE 1N4148M	
D980	8-719-302-38	DIODE RBV-602-01	
		< IC >	
IC150	8-759-095-18	IC HD643325A39F	
IC231	8-759-820-62	IC LB1639	
IC501	8-759-111-44	IC uPC4570C-1	
IC510	8-759-805-14	IC LC7822	
IC511	8-759-805-14	IC LC7822	
IC514	8-759-801-01	IC LC4966	

Ref. No.	Part No.	Description	Remark
IC951	8-759-604-40	IC M5F78M15L	
IC952	8-759-604-46	IC M5F79M15L	
IC953	8-759-604-35	IC M5F78M05L	
		< JACK >	
J501	1-691-260-11	JACK, PIN 6P	
J502	1-691-260-11	JACK, PIN 6P	
J503	1-691-260-11	JACK, PIN 6P	
J504	1-573-520-11	JACK, PIN 4P	
		< COIL >	
* L602	1-420-872-00	COIL, AIR CORE	
* L751	1-420-872-00	COIL, AIR CORE	
		< TRANSISTOR >	
Q250	8-729-119-76	TRANSISTOR 2SA1175-HFE	
Q257	8-729-900-63	TRANSISTOR DTA124ES	
Q501	8-729-620-05	TRANSISTOR 2SC2603-EF	
Q502	8-729-141-30	TRANSISTOR 2SC3623A-LK	
Q503	8-729-900-61	TRANSISTOR DTA114ES	
Q507	8-729-141-30	TRANSISTOR 2SC3623A-LK	
Q508	8-729-141-30	TRANSISTOR 2SC3623A-LK	
Q509	8-729-141-30	TRANSISTOR 2SC3623A-LK	
Q510	8-729-141-30	TRANSISTOR 2SC3623A-LK	
Q511	8-729-141-30	TRANSISTOR 2SC3623A-LK	
Q512	8-729-141-30	TRANSISTOR 2SC3623A-LK	
Q520	8-729-900-80	TRANSISTOR DTC114ES	
Q521	8-729-900-61	TRANSISTOR DTA114ES	
Q522	8-729-900-80	TRANSISTOR DTC114ES	
Q523	8-729-900-61	TRANSISTOR DTA114ES	
Q552	8-729-141-30	TRANSISTOR 2SC3623A-LK	
Q644	8-729-620-05	TRANSISTOR 2SC2603-EF	
Q651	8-729-620-18	TRANSISTOR 2SA979-FG	
Q652	8-729-620-05	TRANSISTOR 2SC2603-EF	
Q653	8-729-140-82	TRANSISTOR 2SA988-PAFAEA	
Q655	8-729-620-05	TRANSISTOR 2SC2603-EF	
Q656	8-729-141-06	TRANSISTOR 2SA1142-QPE	
Q657	8-729-209-15	TRANSISTOR 2SD2012	
Q658	8-729-141-05	TRANSISTOR 2SC2682-QPE	
Q662	8-729-141-46	TRANSISTOR 2SC4431-LK	
Q663	8-729-141-37	TRANSISTOR 2SA1684-LK	
Q664	8-729-321-24	TRANSISTOR 2SA1672-OY	
Q665	8-729-321-21	TRANSISTOR 2SC4387-OY	
Q667	8-729-140-82	TRANSISTOR 2SA988-PAFAEA	
Q702	8-729-209-15	TRANSISTOR 2SD2012	
Q704	8-729-141-46	TRANSISTOR 2SC4431-LK	
Q705	8-729-320-96	TRANSISTOR 2SC2921-OPY	
Q708	8-729-141-37	TRANSISTOR 2SA1684-LK	
Q709	8-729-320-73	TRANSISTOR 2SA1215-OY	

MAIN

Ref. No.	Part No.	Description	Remark	Ref. No.	Part No.	Description	Remark
Q711	8-729-140-82	TRANSISTOR 2SA988-PAFAEA		R522	1-249-429-11	CARBON 10K 5%	1/4W
Q712	8-729-140-82	TRANSISTOR 2SA988-PAFAEA		R523	1-249-426-11	CARBON 5.6K 5%	1/4W
Q713	8-729-140-84	TRANSISTOR 2SC1841-PAFAEA		R524	1-249-441-11	CARBON 100K 5%	1/4W
Q714	8-729-620-05	TRANSISTOR 2SC2603-EF		△R526	1-249-407-11	CARBON 150 5%	1/4W F
Q715	8-729-140-82	TRANSISTOR 2SA988-PAFAEA		R531	1-249-425-11	CARBON 4.7K 5%	1/4W
Q716	8-729-620-05	TRANSISTOR 2SC2603-EF		R533	1-249-425-11	CARBON 4.7K 5%	1/4W
Q752	8-729-209-15	TRANSISTOR 2SD2012		R539	1-249-433-11	CARBON 22K 5%	1/4W
Q754	8-729-141-46	TRANSISTOR 2SC4431-LK		R540	1-249-413-11	CARBON 470 5%	1/4W
Q755	8-729-320-96	TRANSISTOR 2SC2921-OPY		R541	1-249-413-11	CARBON 470 5%	1/4W
Q758	8-729-141-37	TRANSISTOR 2SA1684-LK		R542	1-249-413-11	CARBON 470 5%	1/4W
Q759	8-729-320-73	TRANSISTOR 2SA1215-OY		R543	1-249-413-11	CARBON 470 5%	1/4W
Q767	8-729-140-82	TRANSISTOR 2SA988-PAFAEA		R544	1-249-413-11	CARBON 470 5%	1/4W
Q768	8-729-140-82	TRANSISTOR 2SA988-PAFAEA		R545	1-249-413-11	CARBON 470 5%	1/4W
Q961	8-729-209-15	TRANSISTOR 2SD2012		R547	1-249-417-11	CARBON 1K 5%	1/4W
		< RESISTOR >		R548	1-249-417-11	CARBON 1K 5%	1/4W
R141	1-249-417-11	CARBON 1K 5%	1/4W	R551	1-249-411-11	CARBON 330 5%	1/4W
R191	1-249-417-11	CARBON 1K 5%	1/4W	R552	1-249-441-11	CARBON 100K 5%	1/4W
R251	1-249-422-11	CARBON 2.7K 5%	1/4W	R553	1-249-441-11	CARBON 100K 5%	1/4W
R252	1-249-441-11	CARBON 100K 5%	1/4W	R554	1-249-417-11	CARBON 1K 5%	1/4W
R253	1-249-425-11	CARBON 4.7K 5%	1/4W	R555	1-247-897-11	CARBON 560K 5%	1/4W
R255	1-247-903-00	CARBON 1M 5%	1/4W	R556	1-249-437-11	CARBON 47K 5%	1/4W
R258	1-249-437-11	CARBON 47K 5%	1/4W	R557	1-247-903-00	CARBON 1M 5%	1/4W
R266	1-249-429-11	CARBON 10K 5%	1/4W	R558	1-249-409-11	CARBON 220 5%	1/4W
R267	1-249-429-11	CARBON 10K 5%	1/4W	R559	1-249-409-11	CARBON 220 5%	1/4W
R268	1-249-429-11	CARBON 10K 5%	1/4W	R560	1-249-438-11	CARBON 56K 5%	1/4W
R269	1-249-413-11	CARBON 470 5%	1/4W	R561	1-249-417-11	CARBON 1K 5%	1/4W
R272	1-249-429-11	CARBON 10K 5%	1/4W (D2090)	R563	1-249-417-11	CARBON 1K 5%	1/4W
R273	1-249-437-11	CARBON 47K 5%	1/4W	R564	1-249-417-11	CARBON 1K 5%	1/4W
R274	1-249-429-11	CARBON 10K 5%	1/4W	R565	1-249-417-11	CARBON 1K 5%	1/4W
R275	1-249-429-11	CARBON 10K 5%	1/4W (D2090)	R567	1-249-417-11	CARBON 1K 5%	1/4W
R501	1-249-411-11	CARBON 330 5%	1/4W	R568	1-249-417-11	CARBON 1K 5%	1/4W
R502	1-249-441-11	CARBON 100K 5%	1/4W	R571	1-249-417-11	CARBON 1K 5%	1/4W
R503	1-249-441-11	CARBON 100K 5%	1/4W	R574	1-249-441-11	CARBON 100K 5%	1/4W
R504	1-249-417-11	CARBON 1K 5%	1/4W	R589	1-249-433-11	CARBON 22K 5%	1/4W
R505	1-247-897-11	CARBON 560K 5%	1/4W	R590	1-249-426-11	CARBON 5.6K 5%	1/4W
R506	1-249-437-11	CARBON 47K 5%	1/4W	R591	1-249-441-11	CARBON 100K 5%	1/4W
R507	1-247-903-00	CARBON 1M 5%	1/4W	R592	1-249-433-11	CARBON 22K 5%	1/4W
R508	1-249-409-11	CARBON 220 5%	1/4W	R593	1-249-426-11	CARBON 5.6K 5%	1/4W
R509	1-249-409-11	CARBON 220 5%	1/4W	R594	1-249-426-11	CARBON 5.6K 5%	1/4W
R510	1-249-438-11	CARBON 56K 5%	1/4W	R595	1-249-426-11	CARBON 5.6K 5%	1/4W
R511	1-249-417-11	CARBON 1K 5%	1/4W	R596	1-249-426-11	CARBON 5.6K 5%	1/4W
R513	1-249-417-11	CARBON 1K 5%	1/4W	R597	1-249-417-11	CARBON 1K 5%	1/4W
R514	1-249-417-11	CARBON 1K 5%	1/4W	R598	1-249-417-11	CARBON 1K 5%	1/4W
R515	1-249-417-11	CARBON 1K 5%	1/4W	R599	1-249-426-11	CARBON 5.6K 5%	1/4W
R517	1-249-417-11	CARBON 1K 5%	1/4W	R635	1-260-072-11	CARBON 4.7 5%	1/2W
R518	1-249-417-11	CARBON 1K 5%	1/4W	R644	1-249-429-11	CARBON 10K 5%	1/4W
R520	1-249-441-11	CARBON 100K 5%	1/4W	R650	1-249-434-11	CARBON 27K 5%	1/4W
R521	1-249-417-11	CARBON 1K 5%	1/4W	R651	1-249-417-11	CARBON 1K 5%	1/4W
				R652	1-249-435-11	CARBON 33K 5%	1/4W

The components identified by mark △ or dotted line with mark △ are critical for safety. Replace only with part number specified.

Les composants identifiés par une marque △ sont critiques pour la sécurité. Ne les remplacer que par une pièce portant le numéro spécifié.

MAIN

MAIN VOL

Ref. No.	Part No.	Description	Remark
△R653	1-249-409-11	CARBON	220 5% 1/4W F
△R654	1-249-409-11	CARBON	220 5% 1/4W F
R655	1-249-415-11	CARBON	680 5% 1/4W
R656	1-249-421-11	CARBON	2. 2K 5% 1/4W
R657	1-249-425-11	CARBON	4. 7K 5% 1/4W
R658	1-249-435-11	CARBON	33K 5% 1/4W
R659	1-249-426-11	CARBON	5. 6K 5% 1/4W
R662	1-249-411-11	CARBON	330 5% 1/4W
R663	1-249-435-11	CARBON	33K 5% 1/4W
△R664	1-249-397-11	CARBON	22 5% 1/4W F
△R665	1-249-405-11	CARBON	100 5% 1/4W F
R666	1-249-419-11	CARBON	1. 5K 5% 1/4W
R667	1-249-437-11	CARBON	47K 5% 1/4W
R668	1-249-414-11	CARBON	560 5% 1/4W
△R669	1-249-397-11	CARBON	22 5% 1/4W F
△R670	1-249-405-11	CARBON	100 5% 1/4W F
R671	1-249-431-11	CARBON	15K 5% 1/4W
R672	1-260-076-11	CARBON	10 5% 1/2W
△R675	1-249-389-11	CARBON	4. 7 5% 1/4W F
△R676	1-249-411-11	CARBON	330 5% 1/4W F
△R677	1-249-389-11	CARBON	4. 7 5% 1/4W F
△R678	1-217-611-00	RES, METAL PLATE	0. 1 2W
△R679	1-217-611-00	RES, METAL PLATE	0. 1 2W
R680	1-249-397-11	CARBON	22 5% 1/4W
△R681	1-249-419-11	CARBON	1. 5K 5% 1/4W F
R683	1-249-431-11	CARBON	15K 5% 1/4W
R692	1-249-435-11	CARBON	33K 5% 1/4W
R702	1-249-429-11	CARBON	10K 5% 1/4W
△R707	1-249-405-11	CARBON	100 5% 1/4W F
R708	1-249-419-11	CARBON	1. 5K 5% 1/4W
R709	1-249-437-11	CARBON	47K 5% 1/4W
△R710	1-249-405-11	CARBON	100 5% 1/4W F
△R711	1-249-405-11	CARBON	100 5% 1/4W F
△R712	1-249-393-11	CARBON	10 5% 1/4W F
△R713	1-217-611-00	RES, METAL PLATE	0. 1 2W
△R714	1-217-611-00	RES, METAL PLATE	0. 1 2W
△R715	1-249-393-11	CARBON	10 5% 1/4W F
R725	1-249-419-11	CARBON	1. 5K 5% 1/4W
R726	1-249-417-11	CARBON	1K 5% 1/4W
R727	1-249-431-11	CARBON	15K 5% 1/4W
R728	1-249-431-11	CARBON	15K 5% 1/4W
R729	1-260-072-11	CARBON	4. 7 5% 1/2W
R730	1-260-076-11	CARBON	10 5% 1/2W
R731	1-249-429-11	CARBON	10K 5% 1/4W
R732	1-249-436-11	CARBON	39K 5% 1/4W
R733	1-249-437-11	CARBON	47K 5% 1/4W
R734	1-249-417-11	CARBON	1K 5% 1/4W
R735	1-249-434-11	CARBON	27K 5% 1/4W
△R737	1-249-401-11	CARBON	47 5% 1/4W F

Ref. No.	Part No.	Description	Remark
R746	1-249-433-11	CARBON	22K 5% 1/4W
R750	1-249-415-11	CARBON	680 5% 1/4W
△R757	1-249-405-11	CARBON	100 5% 1/4W F
R758	1-249-419-11	CARBON	1. 5K 5% 1/4W
R759	1-249-437-11	CARBON	47K 5% 1/4W
△R760	1-249-405-11	CARBON	100 5% 1/4W F
△R761	1-249-405-11	CARBON	100 5% 1/4W F
△R762	1-249-393-11	CARBON	10 5% 1/4W F
△R763	1-217-611-00	RES, METAL PLATE	0. 1 2W
△R764	1-217-611-00	RES, METAL PLATE	0. 1 2W
△R765	1-249-393-11	CARBON	10 5% 1/4W F
R775	1-249-419-11	CARBON	1. 5K 5% 1/4W
R776	1-249-417-11	CARBON	1K 5% 1/4W
R777	1-249-431-11	CARBON	15K 5% 1/4W
R778	1-249-431-11	CARBON	15K 5% 1/4W
R779	1-260-072-11	CARBON	4. 7 5% 1/2W
R780	1-260-076-11	CARBON	10 5% 1/2W
△R783	1-247-743-11	CARBON	220 5% 1/2W F
R785	1-249-437-11	CARBON	47K 5% 1/4W
△R787	1-249-401-11	CARBON	47 5% 1/4W F
R796	1-249-433-11	CARBON	22K 5% 1/4W
R966	1-249-381-11	CARBON	1 5% 1/4W
R967	1-249-385-11	CARBON	2. 2 5% 1/6W
△R968	1-249-403-11	CARBON	68 5% 1/4W F
△R969	1-249-403-11	CARBON	68 5% 1/4W F
R970	1-249-426-11	CARBON	5. 6K 5% 1/4W
△R971	1-215-910-00	METAL OXIDE	68 5% 3W F
△R972	1-215-910-00	METAL OXIDE	68 5% 3W F
△R973	1-249-397-11	CARBON	22 5% 1/4W F
R1708	1-249-414-11	CARBON	560 5% 1/4W
R1709	1-249-431-11	CARBON	15K 5% 1/4W
R1758	1-249-414-11	CARBON	560 5% 1/4W
R1759	1-249-431-11	CARBON	15K 5% 1/4W
< RELAY >			
RY501	1-515-614-11	RELAY	
RY602	1-515-676-11	RELAY	
RY701	1-515-741-21	RELAY	
< TEST PIN >			
* TP701	1-560-062-00	PIN, CONNECTOR	4P
* TP702	1-560-060-00	PIN, CONNECTOR	2P

* 1-644-265-11	MAIN VOL BOARD		

< CAPACITOR >			
C401	1-124-903-11	ELECT	1uF 20% 50V

The components identified by mark △ or dotted line with mark △ are critical for safety. Replace only with part number specified.	Les composants identifiés par une marque △ sont critiques pour la sécurité. Ne les remplacer que par une pièce portant le numéro spécifié.
--	--

MAIN VOL

ON SCREEN

Ref.No.	Part No.	Description	Remark		
C402	1-124-903-11	ELECT	1uF	20%	50V
		< CONNECTOR >			
* CNP451	1-564-510-11	PLUG, CONNECTOR 7P			
		< CONNECTOR >			
* CNS450	1-691-177-11	CONNECTOR (BOARD TO BOARD) 7P			
* CNS453	1-568-824-11	SOCKET, CONNECTOR 5P			
		< RESISTOR >			
R401	1-249-407-11	CARBON	150	5%	1/4W
		< VARIABLE RESISTOR >			
RV402	1-241-563-11	RES, VAR, CARBON 100KX4 (MASTER VOLUME)			

* A-4347-944-A	ON SCREEN BOARD, COMPLETE (D2090)				

		< CAPACITOR >			
C119	1-124-907-11	ELECT	10uF	20%	50V
C120	1-164-004-11	CERAMIC CHIP	0.1uF	10%	25V
C121	1-124-907-11	ELECT	10uF	20%	50V
C122	1-163-227-11	CERAMIC CHIP	10PF	5%	50V
C123	1-126-096-11	ELECT	10uF	20%	35V
C124	1-136-162-00	FILM	0.056uF	5%	50V
C125	1-136-153-00	FILM	0.01uF	5%	50V
C126	1-164-004-11	CERAMIC CHIP	0.1uF	10%	25V
C127	1-124-907-11	ELECT	10uF	20%	50V
C128	1-164-004-11	CERAMIC CHIP	0.1uF	10%	25V
C129	1-164-232-11	CERAMIC CHIP	0.01uF		50V
C130	1-163-243-11	CERAMIC CHIP	47PF	5%	50V
C131	1-163-115-00	CERAMIC CHIP	82PF	5%	50V
C132	1-124-907-11	ELECT	10uF	20%	50V
C133	1-124-903-11	ELECT	1uF	20%	50V
C134	1-124-903-11	ELECT	1uF	20%	50V
C135	1-124-903-11	ELECT	1uF	20%	50V
C136	1-124-903-11	ELECT	1uF	20%	50V
C137	1-136-161-00	FILM	0.047uF	5%	50V
C138	1-124-903-11	ELECT	1uF	20%	50V
C140	1-126-096-11	ELECT	10uF	20%	35V
C141	1-163-241-11	CERAMIC CHIP	39PF	5%	50V
C146	1-163-204-00	CERAMIC CHIP	910PF	5%	50V
C147	1-124-477-11	ELECT	47uF	20%	25V
C148	1-164-004-11	CERAMIC CHIP	0.1uF	10%	25V
C150	1-124-903-11	ELECT	1uF	20%	50V
C151	1-130-475-00	MYLAR	0.0022uF	5%	50V
C152	1-130-475-00	MYLAR	0.0022uF	5%	50V

Ref.No.	Part No.	Description	Remark		
C153	1-164-004-11	CERAMIC CHIP	0.1uF	10%	25V
C154	1-124-477-11	ELECT	47uF	20%	25V
C155	1-130-475-00	MYLAR	0.0022uF	5%	50V
C158	1-130-477-00	MYLAR	0.0033uF	5%	50V
C159	1-164-004-11	CERAMIC CHIP	0.1uF	10%	25V
C161	1-130-473-00	MYLAR	0.0015uF	5%	50V
C163	1-164-004-11	CERAMIC CHIP	0.1uF	10%	25V
C164	1-124-477-11	ELECT	47uF	20%	25V
C165	1-164-004-11	CERAMIC CHIP	0.1uF	10%	25V
C167	1-164-004-11	CERAMIC CHIP	0.1uF	10%	25V
C168	1-164-004-11	CERAMIC CHIP	0.1uF	10%	25V
C169	1-164-004-11	CERAMIC CHIP	0.1uF	10%	25V
C170	1-124-477-11	ELECT	47uF	20%	25V
C171	1-163-234-11	CERAMIC CHIP	20PF	5%	50V
C172	1-163-234-11	CERAMIC CHIP	20PF	5%	50V
C173	1-164-004-11	CERAMIC CHIP	0.1uF	10%	25V
C174	1-124-477-11	ELECT	47uF	20%	25V
C175	1-164-004-11	CERAMIC CHIP	0.1uF	10%	25V
C181	1-136-165-00	FILM	0.1uF	5%	50V
C182	1-124-925-11	ELECT	2.2uF	20%	100V
C183	1-163-037-11	CERAMIC CHIP	0.022uF	10%	25V
C184	1-136-154-00	FILM	0.012uF	5%	50V
C185	1-130-476-00	MYLAR	0.0027uF	5%	50V
C186	1-123-382-00	ELECT	3.3uF	20%	100V
C187	1-164-004-11	CERAMIC CHIP	0.1uF	10%	25V
C188	1-124-477-11	ELECT	47uF	20%	25V
C197	1-124-477-11	ELECT	47uF	20%	25V
C198	1-164-004-11	CERAMIC CHIP	0.1uF	10%	25V
C199	1-164-004-11	CERAMIC CHIP	0.1uF	10%	25V
		< JACK >			
* CNJ105	1-568-824-11	SOCKET, CONNECTOR 5P			
* CNJ106	1-568-826-11	SOCKET, CONNECTOR 7P			
		< TRIMMER >			
CT101	1-141-227-00	CAP, TRIMMER	20PF		
		< IC >			
IC105	8-759-931-47	IC	SN74LS628NS		
IC106	8-759-636-55	IC	M5218AFP		
IC107	8-759-250-81	IC	TC5081AP		
IC108	8-759-927-29	IC	SN74HCU04ANS		
IC110	8-759-914-57	IC	BA7230LS		
IC111	8-759-996-03	IC	LVA519S		
IC113	8-759-902-88	IC	SN74LS123NS		
IC114	8-759-907-81	IC	SN74LS221NS		
IC115	8-759-925-85	IC	SN74HC32ANS		
IC117	8-759-922-51	IC	V9938		

ON SCREEN

Ref. No.	Part No.	Description	Remark	Ref. No.	Part No.	Description	Remark
IC118	8-759-922-42	IC MB81464-12		R151	1-216-041-00	METAL CHIP 470 5%	1/10W
IC119	8-759-922-42	IC MB81464-12		R152	1-216-065-00	METAL CHIP 4.7K 5%	1/10W
IC120	8-759-926-80	IC SN74HC573BNS		R153	1-216-059-00	METAL CHIP 2.7K 5%	1/10W
IC121	8-759-926-77	IC SN74HC541ANS		R154	1-216-059-00	METAL CHIP 2.7K 5%	1/10W
IC122	8-759-066-22	IC HN27C101AP12-R001		R155	1-216-065-00	METAL CHIP 4.7K 5%	1/10W
IC123	8-759-927-46	IC SN74HC00ANS		R156	1-216-053-00	METAL CHIP 1.5K 5%	1/10W
IC124	8-759-927-46	IC SN74HC00ANS		R157	1-216-105-00	METAL CHIP 220K 5%	1/10W
IC125	8-759-048-99	IC HD6435208F		R158	1-216-066-00	METAL CHIP 5.1K 5%	1/10W
IC126	8-759-925-82	IC SN74HC21ANS		R160	1-216-083-00	METAL CHIP 27K 5%	1/10W
IC127	8-759-925-76	IC SN74HC08ANS		R161	1-216-059-00	METAL CHIP 2.7K 5%	1/10W
IC128	8-759-824-06	IC LC3664RML-12		R162	1-216-073-00	METAL CHIP 10K 5%	1/10W
IC129	8-759-925-78	IC SN74HC10ANS		R163	1-216-073-00	METAL CHIP 10K 5%	1/10W
IC130	8-759-925-76	IC SN74HC08ANS		R164	1-216-097-00	METAL CHIP 100K 5%	1/10W
IC171	8-759-902-88	IC SN74LS123NS		R165	1-216-063-00	METAL CHIP 3.9K 5%	1/10W
		< COIL >		R166	1-216-049-00	METAL CHIP 1K 5%	1/10W
L101	1-410-470-11	INDUCTOR 10uH		R167	1-216-049-00	METAL CHIP 1K 5%	1/10W
L102	1-410-470-11	INDUCTOR 10uH		R168	1-216-041-00	METAL CHIP 470 5%	1/10W
L103	1-410-470-11	INDUCTOR 10uH		R169	1-216-085-00	METAL CHIP 33K 5%	1/10W
L104	1-410-478-11	INDUCTOR 47uH		R171	1-216-073-00	METAL CHIP 10K 5%	1/10W
		< TRANSISTOR >		R173	1-216-073-00	METAL CHIP 10K 5%	1/10W
Q112	8-729-216-22	TRANSISTOR 2SA1162-G		R177	1-216-689-11	METAL CHIP 39K 0.5%	1/10W
Q113	8-729-216-22	TRANSISTOR 2SA1162-G		R178	1-216-093-00	METAL CHIP 68K 5%	1/10W
Q114	8-729-216-22	TRANSISTOR 2SA1162-G		R179	1-216-064-00	METAL CHIP 4.3K 5%	1/10W
Q115	8-729-113-13	TRANSISTOR FA1A4M-L33		R180	1-216-041-00	METAL CHIP 470 5%	1/10W
Q116	8-729-216-22	TRANSISTOR 2SA1162-G		R181	1-216-041-00	METAL CHIP 470 5%	1/10W
Q117	8-729-113-13	TRANSISTOR FA1A4M-L33		R182	1-216-065-00	METAL CHIP 4.7K 5%	1/10W
Q118	8-729-113-13	TRANSISTOR FA1A4M-L33		R183	1-216-055-00	METAL CHIP 1.8K 5%	1/10W
Q119	8-729-113-72	TRANSISTOR FN1A4M-M33		R184	1-216-069-00	METAL CHIP 6.8K 5%	1/10W
Q120	8-729-100-66	TRANSISTOR 2SC1623-L6		R185	1-216-057-00	METAL CHIP 2.2K 5%	1/10W
		< RESISTOR >		R186	1-216-063-00	METAL CHIP 3.9K 5%	1/10W
R120	1-216-105-00	METAL CHIP 220K 5%	1/10W	R187	1-216-057-00	METAL CHIP 2.2K 5%	1/10W
R130	1-216-049-00	METAL CHIP 1K 5%	1/10W	R188	1-216-057-00	METAL CHIP 2.2K 5%	1/10W
R131	1-216-059-00	METAL CHIP 2.7K 5%	1/10W	R189	1-216-057-00	METAL CHIP 2.2K 5%	1/10W
R132	1-216-097-00	METAL CHIP 100K 5%	1/10W	R1001	1-216-081-00	METAL CHIP 22K 5%	1/10W
R133	1-216-045-00	METAL CHIP 680 5%	1/10W	R1002	1-216-073-00	METAL CHIP 10K 5%	1/10W
R134	1-216-097-00	METAL CHIP 100K 5%	1/10W	R1003	1-216-073-00	METAL CHIP 10K 5%	1/10W
R135	1-216-067-00	METAL CHIP 5.6K 5%	1/10W			< VARIABLE RESISTOR >	
R136	1-216-073-00	METAL CHIP 10K 5%	1/10W	RV103	1-241-761-11	RES, ADJ, CERMET 1K	
R137	1-216-073-00	METAL CHIP 10K 5%	1/10W	RV104	1-238-600-11	RES, ADJ, CARBON 10K	
R138	1-216-073-00	METAL CHIP 10K 5%	1/10W	RV105	1-238-597-11	RES, ADJ, CARBON 1K	
R140	1-216-039-00	METAL CHIP 390 5%	1/10W	RV106	1-238-598-11	RES, ADJ, CARBON 2.2K	
R144	1-216-085-00	METAL CHIP 33K 5%	1/10W	RV107	1-241-761-11	RES, ADJ, CERMET 1K	
R145	1-216-067-00	METAL CHIP 5.6K 5%	1/10W			< THERMISTOR(POSITIVE) >	
R146	1-216-043-00	METAL CHIP 560 5%	1/10W	THP101	1-806-366-11	THERMISTOR (POSITIVE)	
R147	1-216-051-00	METAL CHIP 1.2K 5%	1/10W				
R150	1-216-065-00	METAL CHIP 4.7K 5%	1/10W				

ON SCREEN

POWER SUPPLY

Ref. No.	Part No.	Description	Remark
		< TEST PIN >	
* TP101	1-560-060-00	PIN, CONNECTOR 2P	
* TP102	1-560-060-00	PIN, CONNECTOR 2P	
		< VIBRATOR >	
X102	1-567-505-11	OSCILLATOR, CRYSTAL 3.58MHz	
X103	1-577-121-11	VIBRATOR, CRYSTAL 20MHz	

*	A-4347-955-A	POWER SUPPLY BOARD, COMPLETE (US, CND)	
*	A-4347-956-A	POWER SUPPLY BOARD, COMPLETE (E)	

	1-533-225-11	HOLDER, FUSE	
*	3-309-144-21	HEAT SINK	
	7-682-547-04	SCREW +BVTT 3X6 (S)	
		< BASE POST >	
* BP901	1-535-139-00	BASE POST 19MM (10MM PITCH) 2P	
		< CAPACITOR >	
Δ C901	1-161-744-00	CERAMIC 0.01uF 400V	
C951	1-101-004-00	CERAMIC 0.01uF 50V	
C952	1-101-004-00	CERAMIC 0.01uF 50V	
C953	1-164-073-11	CERAMIC 100PF 10% 50V	
C954	1-124-907-11	ELECT 10uF 20% 50V	
C955	1-124-477-11	ELECT 47uF 20% 25V	
C956	1-124-464-11	ELECT 0.22uF 20% 50V	
C957	1-124-902-00	ELECT 0.47uF 20% 50V	
C958	1-101-004-00	CERAMIC 0.01uF 50V	
C959	1-124-557-11	ELECT 1000uF 20% 25V	
C960	1-124-903-11	ELECT 1uF 20% 50V	
		< CONNECTOR >	
* CNP901	1-564-321-00	PIN, CONNECTOR 2P	
* CNP902	1-580-628-11	PIN, CONNECTOR 3P	
	CNP903	1-568-106-11 PIN, CONNECTOR 4P (E)	
		< CONNECTOR >	
Δ CNS901	1-540-060-11	OUTLET, AC (POLAR) (AC OUTLET)	
* CNS951	1-691-767-11	PLUG (MICRO CONNECTOR) 5P	
		< DIODE >	
D951	8-719-987-63	DIODE 1N4148M	
D952	8-719-987-63	DIODE 1N4148M	
D953	8-719-987-63	DIODE 1N4148M	
D954	8-719-200-02	DIODE 10E2	
D955	8-719-200-02	DIODE 10E2	

Ref. No.	Part No.	Description	Remark
D956	8-719-200-02	DIODE 10E2	
D957	8-719-200-02	DIODE 10E2	
D958	8-719-933-41	DIODE HZS6C3L	
D959	8-719-985-53	DIODE HZS4ALL	
D960	8-719-987-63	DIODE 1N4148M	
D961	8-719-933-41	DIODE HZS6C3L	
		< FUSE >	
Δ F901	1-532-350-00	FUSE (4A) (E)	
Δ F901	1-576-108-11	FUSE (4A) (US, CND)	
Δ F902	1-532-350-00	FUSE (4A) (E)	
Δ F902	1-532-749-11	FUSE, GLASS TUBE (8A) (US, CND)	
Δ F903	1-532-350-00	FUSE (4A) (E)	
Δ F904	1-532-350-00	FUSE (4A) (E)	
		< TRANSISTOR >	
Q952	8-729-620-05	TRANSISTOR 2SC2603-EF	
Q953	8-729-209-15	TRANSISTOR 2SD2012	
Q954	8-729-620-05	TRANSISTOR 2SC2603-EF	
Q955	8-729-119-76	TRANSISTOR 2SA1175-HFE	
Q956	8-729-119-76	TRANSISTOR 2SA1175-HFE	
Q957	8-729-900-63	TRANSISTOR DTA124ES	
Q958	8-729-620-05	TRANSISTOR 2SC2603-EF	
Q959	8-729-900-89	TRANSISTOR DTC144ES	
		< RESISTOR >	
R901	1-202-725-00	SOLID 3.3M 10% 1/2W (US, CND)	
Δ R951	1-247-691-11	CARBON 18 5% 1/4W F	
R952	1-249-417-11	CARBON 1K 5% 1/4W	
R954	1-249-433-11	CARBON 22K 5% 1/4W	
R955	1-249-437-11	CARBON 47K 5% 1/4W	
R956	1-249-425-11	CARBON 4.7K 5% 1/4W	
R957	1-249-429-11	CARBON 10K 5% 1/4W	
R958	1-249-417-11	CARBON 1K 5% 1/4W	
R959	1-249-429-11	CARBON 10K 5% 1/4W	
R960	1-249-429-11	CARBON 10K 5% 1/4W	
R962	1-249-426-11	CARBON 5.6K 5% 1/4W	
R963	1-249-417-11	CARBON 1K 5% 1/4W	
R964	1-249-426-11	CARBON 5.6K 5% 1/4W	
R965	1-247-895-00	CARBON 470K 5% 1/4W	
		< RELAY >	
Δ RY901	1-515-701-11	RELAY (US, CND)	
Δ RY901	1-515-617-11	RELAY (E)	
		< TRANSFORMER >	
Δ T901	1-448-517-21	TRANSFORMER, POWER (US, CND)	
Δ T901	1-448-523-11	TRANSFORMER, POWER (E)	

The components identified by mark Δ or dotted line with mark Δ are critical for safety. Replace only with part number specified.

Les composants identifiés par une marque Δ sont critiques pour la sécurité. Ne les remplacer que par une pièce portant le numéro spécifié.

POWER SUPPLY

SP SW

SP TERMINAL

SUB AMP

Ref. No.	Part No.	Description	Remark
< VOLTAGE SELECTOR >			
△VS901	1-571-437-11	SWITCH, POWER VOLTAGE CHANGE (VOLTAGE SELECTOR) (E)	
< VARISTOR >			
△VZ901	1-807-180-11	VARISTOR SNR-14A300K	
△VZ902	1-807-293-31	VARISTOR SNR-14A221U (E)	

*	1-644-263-11	SP SW BOARD	

< CONNECTOR >			
* CNP704	1-564-242-00	PIN, CONNECTOR 5P	
* CNP710	1-564-674-11	PIN, CONNECTOR 8P	
< JACK >			
J703	1-563-347-11	JACK, LARGE TYPE (HEADPHONES)	
< RESISTOR >			
△R736	1-215-869-11	METAL OXIDE 1K 5% 1W F	
△R786	1-215-869-11	METAL OXIDE 1K 5% 1W F	
< SWITCH >			
S701	1-571-973-11	SWITCH, ROTARY (SPEAKERS)	

*	1-644-261-11	SP TERMINAL BOARD	

< CAPACITOR >			
C641	1-162-294-31	CERAMIC 0.001uF 10% 50V	
C642	1-162-294-31	CERAMIC 0.001uF 10% 50V	
< CONNECTOR >			
* CNP610	1-564-519-11	PLUG, CONNECTOR 4P	
* CNP611	1-564-104-00	PIN, CONNECTOR (B3P-VH) 3P	
* CNP614	1-564-519-11	PLUG, CONNECTOR 4P	
* CNP615	1-564-518-11	PLUG, CONNECTOR 3P	
* CNP715	1-564-674-11	PIN, CONNECTOR 8P	
< DIODE >			
D612	8-719-987-63	DIODE 1N4148M	
D613	8-719-987-63	DIODE 1N4148M	
D616	8-719-987-63	DIODE 1N4148M (D2090)	
D617	8-719-987-63	DIODE 1N4148M (D2090)	
D618	8-719-987-63	DIODE 1N4148M (D2090)	
D619	8-719-987-63	DIODE 1N4148M (D2090)	

Ref. No.	Part No.	Description	Remark
< JACK >			
J601	1-695-219-11	JACK, PIN 4P (SURROUND OUT) (D2090)	
< TRANSISTOR >			
Q641	8-729-620-05	TRANSISTOR 2SC2603-EF	
Q645	8-729-620-05	TRANSISTOR 2SC2603-EF (D2090)	
Q646	8-729-620-05	TRANSISTOR 2SC2603-EF (D2090)	
Q960	8-729-620-05	TRANSISTOR 2SC2603-EF	
< RESISTOR >			
R610	1-249-441-11	CARBON 100K 5% 1/4W (D2090)	
R611	1-249-430-11	CARBON 12K 5% 1/4W (D2090)	
R613	1-249-430-11	CARBON 12K 5% 1/4W (D2090)	
R614	1-249-430-11	CARBON 12K 5% 1/4W (D2090)	
R615	1-249-441-11	CARBON 100K 5% 1/4W (D2090)	
R617	1-249-421-11	CARBON 2.2K 5% 1/4W (D2090)	
R618	1-249-421-11	CARBON 2.2K 5% 1/4W (D2090)	
R619	1-249-421-11	CARBON 2.2K 5% 1/4W (D2090)	
R620	1-249-421-11	CARBON 2.2K 5% 1/4W (D2090)	
R631	1-249-441-11	CARBON 100K 5% 1/4W (D2090)	
R632	1-249-441-11	CARBON 100K 5% 1/4W (D2090)	
R633	1-249-429-11	CARBON 10K 5% 1/4W (D2090)	
R634	1-249-429-11	CARBON 10K 5% 1/4W (D2090)	
R643	1-249-429-11	CARBON 10K 5% 1/4W	
R961	1-249-429-11	CARBON 10K 5% 1/4W	
< RELAY >			
RY603	1-515-790-11	RELAY	
RY605	1-515-793-11	RELAY	
RY606	1-515-793-11	RELAY (D2090)	
< SWITCH >			
S601	1-692-196-11	SWITCH, SLIDE (AMP MODE) (D2090)	
< TERMINAL >			
TM602	1-536-706-00	TERMINAL BOARD (SP) (FRONT SPEAKERS A, B)	
TM701	1-536-706-00	TERMINAL BOARD (SP) (CENTER SPEAKERS, REAR SPEAKERS)	

*	A-4347-960-A	SUB AMP BOARD, COMPLETE	

< CAPACITOR >			
C601	1-124-907-11	ELECT 10uF 20% 50V	
C602	1-162-282-31	CERAMIC 100PF 10% 50V	
C603	1-126-233-11	ELECT 22uF 20% 50V	
C604	1-124-667-11	ELECT 10uF 20% 100V	

The components identified by mark △ or dotted line with mark △ are critical for safety. Replace only with part number specified.	Les composants identifiés par une marque △ sont critiques pour la sécurité. Ne les remplacer que par une pièce portant le numéro spécifié.
--	--

SUB AMP

SURROUND

Ref. No.	Part No.	Description	Remark		
C607	1-136-157-00	FILM	0.022uF	5%	50V
C621	1-124-907-11	ELECT	10uF	20%	50V
C622	1-162-282-31	CERAMIC	100PF	10%	50V
C623	1-126-233-11	ELECT	22uF	20%	50V
C624	1-124-667-11	ELECT	10uF	20%	100V
C627	1-136-157-00	FILM	0.022uF	5%	50V
< CONNECTOR >					
* CNP631	1-564-506-11	PLUG, CONNECTOR 3P			
* CNP632	1-564-506-11	PLUG, CONNECTOR 3P			
* CNP633	1-564-506-11	PLUG, CONNECTOR 3P			
CNP634	1-691-766-11	PLUG, CONNECTOR 4P			
< DIODE >					
D620	8-719-987-63	DIODE 1N4148M			
D640	8-719-987-63	DIODE 1N4148M			
< IC >					
IC601	8-759-085-89	IC LM3875-S			
IC621	8-759-085-89	IC LM3875-S			
< COIL >					
* L601	1-420-872-00	COIL, AIR CORE			
* L621	1-420-872-00	COIL, AIR CORE			
< TRANSISTOR >					
Q620	8-729-140-82	TRANSISTOR 2SA988-PAFAEA			
Q640	8-729-140-82	TRANSISTOR 2SA988-PAFAEA			
< RESISTOR >					
R601	1-249-409-11	CARBON	220	5%	1/4W
R602	1-249-441-11	CARBON	100K	5%	1/4W
R603	1-249-415-11	CARBON	680	5%	1/4W
R604	1-249-441-11	CARBON	100K	5%	1/4W
R605	1-249-419-11	CARBON	1.5K	5%	1/4W
R606	1-249-431-11	CARBON	15K	5%	1/4W
R607	1-249-438-11	CARBON	56K	5%	1/4W
△R608	1-249-393-11	CARBON	10	5%	1/4W F
△R609	1-217-151-00	RES, METAL PLATE	0.22		2W
R611	1-249-389-11	CARBON	4.7	5%	1/4W
R621	1-249-409-11	CARBON	220	5%	1/4W
R622	1-249-441-11	CARBON	100K	5%	1/4W
R623	1-249-420-11	CARBON	1.8K	5%	1/4W
R624	1-249-441-11	CARBON	100K	5%	1/4W
R625	1-249-419-11	CARBON	1.5K	5%	1/4W
R626	1-249-431-11	CARBON	15K	5%	1/4W
R627	1-249-437-11	CARBON	47K	5%	1/4W
△R628	1-249-393-11	CARBON	10	5%	1/4W F

Ref. No.	Part No.	Description	Remark		
△R629	1-217-151-00	RES, METAL PLATE	0.22		2W
R631	1-249-389-11	CARBON	4.7	5%	1/4W
△R691	1-249-401-11	CARBON	47	5%	1/4W F

*	A-4347-979-A SURROUND BOARD, COMPLETE				

< CAPACITOR >					
C301	1-124-477-11	ELECT	47uF	20%	25V
C302	1-164-004-11	CERAMIC CHIP	0.1uF	10%	25V
C303	1-164-004-11	CERAMIC CHIP	0.1uF	10%	25V
C304	1-124-477-11	ELECT	47uF	20%	25V
C305	1-136-153-00	FILM	0.01uF	5%	50V
C306	1-164-232-11	CERAMIC CHIP	0.01uF		50V
C307	1-124-907-11	ELECT	10uF	20%	50V
C308	1-124-477-11	ELECT	47uF	20%	25V
C309	1-126-233-11	ELECT	22uF	20%	50V
C310	1-126-233-11	ELECT	22uF	20%	50V
C311	1-136-165-00	FILM	0.1uF	5%	50V
C312	1-164-004-11	CERAMIC CHIP	0.1uF	10%	25V
C313	1-110-340-11	MYLAR	270PF	5%	50V
C314	1-164-073-11	CERAMIC	100PF	10%	50V
C315	1-164-073-11	CERAMIC	100PF	10%	50V
C316	1-124-907-11	ELECT	10uF	20%	50V
C317	1-124-907-11	ELECT	10uF	20%	50V
C318	1-110-341-11	MYLAR	330PF	5%	50V
C319	1-164-073-11	CERAMIC	100PF	10%	50V
C320	1-110-341-11	MYLAR	330PF	5%	50V
C321	1-163-109-00	CERAMIC CHIP	47PF	5%	50V
C322	1-126-233-11	ELECT	22uF	20%	50V
C323	1-164-004-11	CERAMIC CHIP	0.1uF	10%	25V
C324	1-124-907-11	ELECT	10uF	20%	50V
C325	1-164-004-11	CERAMIC CHIP	0.1uF	10%	25V
C326	1-124-477-11	ELECT	47uF	20%	25V
C327	1-126-233-11	ELECT	22uF	20%	50V
C328	1-164-004-11	CERAMIC CHIP	0.1uF	10%	25V
C329	1-164-004-11	CERAMIC CHIP	0.1uF	10%	25V
C330	1-124-477-11	ELECT	47uF	20%	25V
C331	1-124-477-11	ELECT	47uF	20%	25V
C332	1-130-473-00	MYLAR	0.0015uF	5%	50V
C333	1-164-004-11	CERAMIC CHIP	0.1uF	10%	25V
C334	1-163-001-11	CERAMIC CHIP	220PF	10%	50V
C335	1-130-478-00	MYLAR	0.0039uF	5%	50V
C336	1-126-233-11	ELECT	22uF	20%	50V
C337	1-136-165-00	FILM	0.1uF	5%	50V
C340	1-164-004-11	CERAMIC CHIP	0.1uF	10%	25V
C341	1-164-004-11	CERAMIC CHIP	100PF	5%	50V
C342	1-164-004-11	CERAMIC CHIP	100PF	5%	50V

The components identified by mark △ or dotted line with mark △ are critical for safety. Replace only with part number specified.

Les composants identifiés par une marque △ sont critiques pour la sécurité. Ne les remplacer que par une pièce portant le numéro spécifié.

SURROUND

Ref. No.	Part No.	Description	Remark	Ref. No.	Part No.	Description	Remark
C351	1-126-233-11	ELECT	22uF 20% 50V	C429	1-124-477-11	ELECT	47uF 20% 25V
C352	1-164-004-11	CERAMIC CHIP	0.1uF 10% 25V	C430	1-164-004-11	CERAMIC CHIP	0.1uF 10% 25V
C353	1-164-232-11	CERAMIC CHIP	0.01uF 50V	C431	1-124-478-11	ELECT	100uF 20% 25V
C354	1-136-153-00	FILM	0.01uF 5% 50V	C432	1-164-004-11	CERAMIC CHIP	0.1uF 10% 25V
C355	1-164-004-11	CERAMIC CHIP	0.1uF 10% 25V	C433	1-164-004-11	CERAMIC CHIP	0.1uF 10% 25V
C356	1-124-477-11	ELECT	47uF 20% 25V	C434	1-126-233-11	ELECT	22uF 20% 50V
C357	1-124-907-11	ELECT	10uF 20% 50V	C435	1-164-004-11	CERAMIC CHIP	0.1uF 10% 25V
C359	1-126-233-11	ELECT	22uF 20% 50V	C436	1-126-233-11	ELECT	22uF 20% 50V
C363	1-110-340-11	MYLAR	270PF 5% 50V	C437	1-164-004-11	CERAMIC CHIP	0.1uF 10% 25V
C364	1-164-073-11	CERAMIC	100PF 10% 50V	C438	1-126-233-11	ELECT	22uF 20% 50V
C365	1-164-073-11	CERAMIC	100PF 10% 50V	C439	1-164-004-11	CERAMIC CHIP	0.1uF 10% 25V
C366	1-124-907-11	ELECT	10uF 20% 50V	C440	1-164-004-11	CERAMIC CHIP	0.1uF 10% 25V
C367	1-124-907-11	ELECT	10uF 20% 50V	C441	1-126-233-11	ELECT	22uF 20% 50V
C368	1-110-341-11	MYLAR	330PF 5% 50V	C442	1-164-004-11	CERAMIC CHIP	0.1uF 10% 25V
C369	1-164-073-11	CERAMIC	100PF 10% 50V	C443	1-164-004-11	CERAMIC CHIP	0.1uF 10% 25V
C370	1-110-341-11	MYLAR	330PF 5% 50V	C444	1-126-233-11	ELECT	22uF 20% 50V
C371	1-163-109-00	CERAMIC CHIP	47PF 5% 50V	C445	1-164-004-11	CERAMIC CHIP	0.1uF 10% 25V
C372	1-126-233-11	ELECT	22uF 20% 50V	C446	1-164-004-11	CERAMIC CHIP	0.1uF 10% 25V
C373	1-164-004-11	CERAMIC CHIP	0.1uF 10% 25V	C451	1-163-235-11	CERAMIC CHIP	22PF 5% 50V
C374	1-124-907-11	ELECT	10uF 20% 50V	C452	1-163-243-11	CERAMIC CHIP	47PF 5% 50V
C375	1-164-004-11	CERAMIC CHIP	0.1uF 10% 25V	C462	1-124-477-11	ELECT	47uF 20% 25V
C376	1-124-477-11	ELECT	47uF 20% 25V	C463	1-164-004-11	CERAMIC CHIP	0.1uF 10% 25V
C377	1-126-233-11	ELECT	22uF 20% 50V	C464	1-130-481-00	MYLAR	0.0068uF 5% 50V
C378	1-164-004-11	CERAMIC CHIP	0.1uF 10% 25V	C465	1-163-235-11	CERAMIC CHIP	22PF 5% 50V
C381	1-124-907-11	ELECT	10uF 20% 50V	C466	1-163-235-11	CERAMIC CHIP	22PF 5% 50V
C382	1-130-473-00	MYLAR	0.0015uF 5% 50V	C468	1-124-907-11	ELECT	10uF 20% 50V
C383	1-124-907-11	ELECT	10uF 20% 50V	C469	1-124-907-11	ELECT	10uF 20% 50V
C384	1-163-001-11	CERAMIC CHIP	220PF 10% 50V	C470	1-124-907-11	ELECT	10uF 20% 50V
C385	1-130-478-00	MYLAR	0.0039uF 5% 50V	C471	1-124-907-11	ELECT	10uF 20% 50V
C386	1-126-233-11	ELECT	22uF 20% 50V	C472	1-124-907-11	ELECT	10uF 20% 50V
C392	1-124-903-11	ELECT	1uF 20% 50V	C473	1-124-907-11	ELECT	10uF 20% 50V
C410	1-124-903-11	ELECT	1uF 20% 50V	C474	1-124-907-11	ELECT	10uF 20% 50V
C411	1-124-478-11	ELECT	100uF 20% 25V	C475	1-124-907-11	ELECT	10uF 20% 50V
C412	1-164-004-11	CERAMIC CHIP	0.1uF 10% 25V	C476	1-124-903-11	ELECT	1uF 20% 50V
C413	1-163-099-00	CERAMIC CHIP	18PF 5% 50V	C477	1-124-903-11	ELECT	1uF 20% 50V
C414	1-164-004-11	CERAMIC CHIP	0.1uF 10% 25V	C478	1-124-478-11	ELECT	100uF 20% 25V
C415	1-164-232-11	CERAMIC CHIP	0.01uF 50V	C479	1-136-171-00	FILM	0.33uF 5% 50V
C416	1-163-093-00	CERAMIC CHIP	10PF 5% 50V	C480	1-136-165-00	FILM	0.1uF 5% 50V
C417	1-126-233-11	ELECT	22uF 20% 50V	C481	1-136-159-00	FILM	0.033uF 5% 50V
C418	1-163-093-00	CERAMIC CHIP	10PF 5% 50V	C482	1-130-479-00	MYLAR	0.0047uF 5% 50V
C419	1-163-105-00	CERAMIC CHIP	33PF 5% 50V	C483	1-130-482-00	MYLAR	0.0082uF 5% 50V
C421	1-164-004-11	CERAMIC CHIP	0.1uF 10% 25V	C484	1-136-158-00	FILM	0.027uF 5% 50V
C422	1-124-478-11	ELECT	100uF 20% 25V	C485	1-126-233-11	ELECT	22uF 20% 50V
C423	1-124-478-11	ELECT	100uF 20% 25V	C486	1-124-478-11	ELECT	100uF 20% 25V
C424	1-164-004-11	CERAMIC CHIP	0.1uF 10% 25V	C487	1-124-903-11	ELECT	1uF 20% 50V
C425	1-164-004-11	CERAMIC CHIP	0.1uF 10% 25V	< CONNECTOR >			
C426	1-163-009-11	CERAMIC CHIP	0.001uF 10% 50V	* CNP302 1-564-506-11 PLUG, CONNECTOR 6P			
C427	1-164-004-11	CERAMIC CHIP	0.1uF 10% 25V				
C428	1-164-004-11	CERAMIC CHIP	0.1uF 10% 25V				

SURROUND

Ref. No.	Part No.	Description	Remark	Ref. No.	Part No.	Description	Remark
		< CONNECTOR >		L413	1-410-377-31	INDUCTOR CHIP 4.7uH	
* CNS301	1-565-484-11	CONNECTOR, BOARD TO BOARD 8P				< TRANSISTOR >	
CNS303	1-695-218-11	SOCKET, CONNECTOR 33P		Q301	8-729-107-46	TRANSISTOR 2SC3624A-L15	
		< DIODE >		Q302	8-729-107-46	TRANSISTOR 2SC3624A-L15	
D402	8-719-918-45	DIODE KV1310		Q303	8-729-107-46	TRANSISTOR 2SC3624A-L15	
D404	8-719-210-33	DIODE EC10DS2		Q304	8-729-107-46	TRANSISTOR 2SC3624A-L15	
		< IC >		Q305	8-729-107-46	TRANSISTOR 2SC3624A-L15	
IC301	8-759-504-36	IC CS5339-KP		Q306	8-729-107-46	TRANSISTOR 2SC3624A-L15	
IC302	8-759-636-55	IC M5218AFP		Q351	8-729-107-46	TRANSISTOR 2SC3624A-L15	
IC303	8-759-708-05	IC NJM78L05A		Q352	8-729-107-46	TRANSISTOR 2SC3624A-L15	
IC304	8-759-700-65	IC NJM79L05A		Q353	8-729-107-46	TRANSISTOR 2SC3624A-L15	
IC305	8-759-636-55	IC M5218AFP		Q354	8-729-107-46	TRANSISTOR 2SC3624A-L15	
IC306	8-759-636-55	IC M5218AFP		Q355	8-729-107-46	TRANSISTOR 2SC3624A-L15	
IC307	8-759-040-59	IC LC7883K		Q356	8-729-107-46	TRANSISTOR 2SC3624A-L15	
IC308	8-759-636-55	IC M5218AFP		Q403	8-729-200-56	TRANSISTOR 2SK241-GR	
IC309	8-759-636-55	IC M5218AFP		Q404	8-729-200-56	TRANSISTOR 2SK241-GR	
IC355	8-759-636-55	IC M5218AFP		Q406	8-729-207-68	TRANSISTOR RN2402	
IC356	8-759-636-55	IC M5218AFP		Q407	8-729-207-68	TRANSISTOR RN2402	
IC403	8-759-708-05	IC NJM78L05A		Q408	8-729-207-68	TRANSISTOR RN2402	
IC404	8-759-075-34	IC LC83015		Q409	8-729-207-68	TRANSISTOR RN2402	
IC405	8-752-342-65	IC CXD2560M		Q411	8-729-805-45	TRANSISTOR 2SC3395	
IC406	8-759-823-77	IC LC324256-10		Q412	8-729-805-69	TRANSISTOR 2SA1341	
IC407	8-759-243-19	IC TC7SU04F		Q413	8-729-805-45	TRANSISTOR 2SC3395	
IC408	8-752-335-52	IC CXD2552Q-2				< RESISTOR >	
IC409	8-759-250-81	IC TC5081AP		R301	1-216-085-00	METAL CHIP 33K 5% 1/10W	
IC410	8-759-926-74	IC SN74HC393ANS		R302	1-216-017-00	METAL CHIP 47 5% 1/10W	
IC411	8-759-242-70	IC TC7WU04F		R303	1-216-025-00	METAL CHIP 100 5% 1/10W	
IC412	8-759-708-08	IC NJM78L08A		R304	1-216-073-00	METAL CHIP 10K 5% 1/10W	
IC417	8-759-973-98	IC YM3623B		R305	1-216-097-00	METAL CHIP 100K 5% 1/10W	
IC418	8-759-820-11	IC LC7535		R306	1-216-097-00	METAL CHIP 100K 5% 1/10W	
IC419	8-759-636-55	IC M5218AFP		R308	1-216-085-00	METAL CHIP 33K 5% 1/10W	
IC420	8-759-823-24	IC LA2730		R309	1-216-113-00	METAL CHIP 470K 5% 1/10W	
IC421	8-759-801-01	IC LC4966		R310	1-216-033-00	METAL CHIP 220 5% 1/10W	
		< COIL >		R311	1-216-072-00	METAL CHIP 9.1K 5% 1/10W	
L301	1-410-377-31	INDUCTOR CHIP 4.7uH		R312	1-216-065-00	METAL CHIP 4.7K 5% 1/10W	
L302	1-410-377-31	INDUCTOR CHIP 4.7uH		R313	1-216-072-00	METAL CHIP 9.1K 5% 1/10W	
L402	1-426-850-11	COIL (RF)		R314	1-216-065-00	METAL CHIP 4.7K 5% 1/10W	
L404	1-410-377-31	INDUCTOR CHIP 4.7uH		R315	1-216-080-00	METAL CHIP 20K 5% 1/10W	
L405	1-410-377-31	INDUCTOR CHIP 4.7uH		R316	1-216-067-00	METAL CHIP 5.6K 5% 1/10W	
L406	1-410-377-31	INDUCTOR CHIP 4.7uH		R317	1-216-067-00	METAL CHIP 5.6K 5% 1/10W	
L407	1-410-377-31	INDUCTOR CHIP 4.7uH		R318	1-216-080-00	METAL CHIP 20K 5% 1/10W	
L408	1-410-377-31	INDUCTOR CHIP 4.7uH		R319	1-216-067-00	METAL CHIP 5.6K 5% 1/10W	
L409	1-410-377-31	INDUCTOR CHIP 4.7uH		R320	1-216-067-00	METAL CHIP 5.6K 5% 1/10W	
L410	1-410-377-31	INDUCTOR CHIP 4.7uH		R321	1-216-061-00	METAL CHIP 3.3K 5% 1/10W	
				R322	1-216-097-00	METAL CHIP 100K 5% 1/10W	
				R323	1-216-062-00	METAL CHIP 3.6K 5% 1/10W	

SURROUND

Ref. No.	Part No.	Description	Remark			Ref. No.	Part No.	Description	Remark		
R324	1-216-065-00	METAL CHIP	4.7K	5%	1/10W	R375	1-216-061-00	METAL CHIP	3.3K	5%	1/10W
R325	1-216-061-00	METAL CHIP	3.3K	5%	1/10W	R376	1-216-097-00	METAL CHIP	100K	5%	1/10W
R326	1-216-097-00	METAL CHIP	100K	5%	1/10W	R377	1-216-073-00	METAL CHIP	10K	5%	1/10W
R327	1-216-073-00	METAL CHIP	10K	5%	1/10W	R378	1-216-065-00	METAL CHIP	4.7K	5%	1/10W
R328	1-216-065-00	METAL CHIP	4.7K	5%	1/10W	R379	1-216-055-00	METAL CHIP	1.8K	5%	1/10W
R329	1-216-055-00	METAL CHIP	1.8K	5%	1/10W	R380	1-216-049-00	METAL CHIP	1K	5%	1/10W
R330	1-216-049-00	METAL CHIP	1K	5%	1/10W	R381	1-216-097-00	METAL CHIP	100K	5%	1/10W
R331	1-216-097-00	METAL CHIP	100K	5%	1/10W	R382	1-216-054-00	METAL GLAZE	1.6K	5%	1/10W
R332	1-216-054-00	METAL GLAZE	1.6K	5%	1/10W	R383	1-216-065-00	METAL CHIP	4.7K	5%	1/10W
R333	1-216-065-00	METAL CHIP	4.7K	5%	1/10W	R384	1-216-105-00	METAL CHIP	220K	5%	1/10W
R334	1-216-105-00	METAL CHIP	220K	5%	1/10W	R385	1-216-049-00	METAL CHIP	1K	5%	1/10W
R335	1-216-049-00	METAL CHIP	1K	5%	1/10W	R386	1-216-049-00	METAL CHIP	1K	5%	1/10W
R336	1-216-049-00	METAL CHIP	1K	5%	1/10W	R387	1-216-065-00	METAL CHIP	4.7K	5%	1/10W
R337	1-216-065-00	METAL CHIP	4.7K	5%	1/10W	R388	1-216-065-00	METAL CHIP	4.7K	5%	1/10W
R338	1-216-065-00	METAL CHIP	4.7K	5%	1/10W	R389	1-216-041-00	METAL CHIP	470	5%	1/10W
R340	1-216-033-00	METAL CHIP	220	5%	1/10W	R390	1-216-041-00	METAL CHIP	470	5%	1/10W
R341	1-216-061-00	METAL CHIP	3.3K	5%	1/10W	R391	1-216-061-00	METAL CHIP	3.3K	5%	1/10W
R342	1-216-061-00	METAL CHIP	3.3K	5%	1/10W	R392	1-216-061-00	METAL CHIP	3.3K	5%	1/10W
R343	1-216-061-00	METAL CHIP	3.3K	5%	1/10W	R393	1-216-061-00	METAL CHIP	3.3K	5%	1/10W
R344	1-216-059-00	METAL CHIP	2.7K	5%	1/10W	R394	1-216-049-00	METAL CHIP	1K	5%	1/10W
R346	1-216-065-00	METAL CHIP	4.7K	5%	1/10W	R395	1-216-041-00	METAL CHIP	470	5%	1/10W
R347	1-216-049-00	METAL CHIP	1K	5%	1/10W	R396	1-216-065-00	METAL CHIP	4.7K	5%	1/10W
R348	1-216-049-00	METAL CHIP	1K	5%	1/10W	R397	1-216-041-00	METAL CHIP	470	5%	1/10W
R349	1-216-049-00	METAL CHIP	1K	5%	1/10W	R399	1-216-085-00	METAL CHIP	33K	5%	1/10W
R350	1-216-049-00	METAL CHIP	1K	5%	1/10W	R400	1-216-049-00	METAL CHIP	1K	5%	1/10W
R351	1-216-001-00	METAL CHIP	10	5%	1/10W	R401	1-216-041-00	METAL CHIP	470	5%	1/10W
R352	1-216-017-00	METAL CHIP	47	5%	1/10W	R409	1-216-049-00	METAL CHIP	1K	5%	1/10W
R353	1-216-025-00	METAL CHIP	100	5%	1/10W	R410	1-216-049-00	METAL CHIP	1K	5%	1/10W
R354	1-216-073-00	METAL CHIP	10K	5%	1/10W	R411	1-216-097-00	METAL CHIP	100K	5%	1/10W
R355	1-216-097-00	METAL CHIP	100K	5%	1/10W	R412	1-216-097-00	METAL CHIP	100K	5%	1/10W
R356	1-216-097-00	METAL CHIP	100K	5%	1/10W	R413	1-216-049-00	METAL CHIP	1K	5%	1/10W
R357	1-216-041-00	METAL CHIP	470	5%	1/10W	R414	1-216-049-00	METAL CHIP	1K	5%	1/10W
R358	1-216-085-00	METAL CHIP	33K	5%	1/10W	R416	1-216-049-00	METAL CHIP	1K	5%	1/10W
R359	1-216-085-00	METAL CHIP	33K	5%	1/10W	R417	1-216-089-00	METAL CHIP	47K	5%	1/10W
R360	1-216-041-00	METAL CHIP	470	5%	1/10W	R418	1-216-049-00	METAL CHIP	1K	5%	1/10W
R361	1-216-072-00	METAL CHIP	9.1K	5%	1/10W	R419	1-216-061-00	METAL CHIP	3.3K	5%	1/10W
R362	1-216-065-00	METAL CHIP	4.7K	5%	1/10W	R420	1-216-061-00	METAL CHIP	3.3K	5%	1/10W
R363	1-216-072-00	METAL CHIP	9.1K	5%	1/10W	R421	1-216-041-00	METAL CHIP	470	5%	1/10W
R364	1-216-065-00	METAL CHIP	4.7K	5%	1/10W	R422	1-216-049-00	METAL CHIP	1K	5%	1/10W
R365	1-216-080-00	METAL CHIP	20K	5%	1/10W	R423	1-216-073-00	METAL CHIP	10K	5%	1/10W
R366	1-216-067-00	METAL CHIP	5.6K	5%	1/10W	R424	1-216-097-00	METAL CHIP	100K	5%	1/10W
R367	1-216-067-00	METAL CHIP	5.6K	5%	1/10W	R425	1-216-121-00	METAL CHIP	1M	5%	1/10W
R368	1-216-080-00	METAL CHIP	20K	5%	1/10W	R426	1-216-295-00	METAL CHIP	0	5%	1/10W
R369	1-216-067-00	METAL CHIP	5.6K	5%	1/10W	R427	1-216-071-00	METAL CHIP	8.2K	5%	1/10W
R370	1-216-067-00	METAL CHIP	5.6K	5%	1/10W	R428	1-216-073-00	METAL CHIP	10K	5%	1/10W
R371	1-216-061-00	METAL CHIP	3.3K	5%	1/10W	R429	1-216-097-00	METAL CHIP	100K	5%	1/10W
R372	1-216-097-00	METAL CHIP	100K	5%	1/10W	R430	1-216-049-00	METAL CHIP	1K	5%	1/10W
R373	1-216-062-00	METAL CHIP	3.6K	5%	1/10W	R433	1-216-049-00	METAL CHIP	1K	5%	1/10W
R374	1-216-065-00	METAL CHIP	4.7K	5%	1/10W	R434	1-216-049-00	METAL CHIP	1K	5%	1/10W

SURROUND

SYSTEM POWER SW

TRANS TERMINAL (1)

TRANS TERMINAL (2)

Ref. No.	Part No.	Description	Remark		
R435	1-216-025-00	METAL CHIP	100	5%	1/10W
R436	1-216-121-00	METAL CHIP	1M	5%	1/10W
R437	1-216-121-00	METAL CHIP	1M	5%	1/10W
R438	1-216-121-00	METAL CHIP	1M	5%	1/10W
R439	1-216-121-00	METAL CHIP	1M	5%	1/10W
R440	1-216-121-00	METAL CHIP	1M	5%	1/10W
R441	1-216-081-00	METAL CHIP	22K	5%	1/10W
R442	1-216-081-00	METAL CHIP	22K	5%	1/10W
R443	1-216-025-00	METAL CHIP	100	5%	1/10W
R444	1-216-041-00	METAL CHIP	470	5%	1/10W
R445	1-216-041-00	METAL CHIP	470	5%	1/10W
R446	1-216-041-00	METAL CHIP	470	5%	1/10W
R447	1-216-041-00	METAL CHIP	470	5%	1/10W
R448	1-216-025-00	METAL CHIP	100	5%	1/10W
R451	1-216-097-00	METAL CHIP	100K	5%	1/10W
R452	1-216-097-00	METAL CHIP	100K	5%	1/10W
R463	1-216-029-00	METAL CHIP	150	5%	1/10W
R464	1-216-025-00	METAL CHIP	100	5%	1/10W
R465	1-216-121-00	METAL CHIP	1M	5%	1/10W
R467	1-216-080-00	METAL CHIP	20K	5%	1/10W
R468	1-216-073-00	METAL CHIP	10K	5%	1/10W
R469	1-216-107-00	METAL CHIP	270K	5%	1/10W
R470	1-216-073-00	METAL CHIP	10K	5%	1/10W
R471	1-216-077-00	METAL CHIP	15K	5%	1/10W
R472	1-216-083-00	METAL CHIP	27K	5%	1/10W
R473	1-216-068-00	METAL CHIP	6.2K	5%	1/10W
R474	1-216-089-00	METAL CHIP	47K	5%	1/10W
R475	1-216-061-00	METAL CHIP	3.3K	5%	1/10W
R476	1-216-107-00	METAL CHIP	270K	5%	1/10W
R477	1-216-081-00	METAL CHIP	22K	5%	1/10W
R478	1-216-041-00	METAL CHIP	470	5%	1/10W
R479	1-216-031-00	METAL CHIP	180	5%	1/10W
R480	1-216-075-00	METAL CHIP	12K	5%	1/10W
R481	1-216-065-00	METAL CHIP	4.7K	5%	1/10W
R482	1-216-069-00	METAL CHIP	6.8K	5%	1/10W
R483	1-216-089-00	METAL CHIP	47K	5%	1/10W
R485	1-216-295-00	METAL CHIP	0	5%	1/10W
R486	1-216-295-00	METAL CHIP	0	5%	1/10W
R488	1-216-295-00	METAL CHIP	0	5%	1/10W
R490	1-216-049-00	METAL CHIP	1K	5%	1/10W
R491	1-216-049-00	METAL CHIP	1K	5%	1/10W
R492	1-216-049-00	METAL CHIP	1K	5%	1/10W
R493	1-216-049-00	METAL CHIP	1K	5%	1/10W
R494	1-216-049-00	METAL CHIP	1K	5%	1/10W
R495	1-216-049-00	METAL CHIP	1K	5%	1/10W
R496	1-216-049-00	METAL CHIP	1K	5%	1/10W
R497	1-216-049-00	METAL CHIP	1K	5%	1/10W
R498	1-216-041-00	METAL CHIP	470	5%	1/10W
R499	1-216-041-00	METAL CHIP	470	5%	1/10W

Ref. No.	Part No.	Description	Remark		
R4001	1-216-080-00	METAL CHIP	20K	5%	1/10W
R4002	1-216-051-00	METAL CHIP	1.2K	5%	1/10W
R4051	1-216-080-00	METAL CHIP	20K	5%	1/10W
R4052	1-216-051-00	METAL CHIP	1.2K	5%	1/10W
< VIBRATOR >					
X401	1-577-269-11	VIBRATOR, CRYSTAL	18.432Hz		
X402	1-567-970-11	VIBRATOR, CRYSTAL			

*	1-644-253-11	SYSTEM POWER SW BOARD			

< CONNECTOR >					
*	CNS202	1-565-295-11	PLUG, CONNECTOR	4P	
< SWITCH >					
S244	1-554-303-21	SWITCH, TACTILE (POWER)			

*	1-644-271-12	TRANS TERMINAL(1) BOARD			

1-533-225-11	HOLDER, FUSE				
< CONNECTOR >					
* CNP971	1-564-506-11	PLUG, CONNECTOR	3P		
* CNP972	1-564-214-11	PIN, CONNECTOR (B3PS-VH)	3P		
* CNP973	1-564-321-00	PIN, CONNECTOR	2P (US, CND)		
< DIODE >					
△D150	8-719-014-82	DIODE	UZP-6.8B		
< FUSE >					
△F957	1-576-109-11	FUSE (5A)			
△F959	1-576-109-11	FUSE (5A)			

*	1-644-272-11	TRANS TERMINAL(2) BOARD			

1-533-225-11	HOLDER, FUSE				
< CONNECTOR >					
* CNP970	1-564-242-00	PIN, CONNECTOR	5P		
* CNP974	1-564-506-11	PLUG, CONNECTOR	3P		
< DIODE >					
D966	8-719-987-63	DIODE	1N4148M		
D967	8-719-987-63	DIODE	1N4148M		

The components identified by mark \triangle or dotted line with mark. \triangle are critical for safety. Replace only with part number specified.

Les composants identifiés par une marque \triangle sont critiques pour la sécurité. Ne les remplacer que par une pièce portant le numéro spécifié.

TRANS TERMINAL (2)

TRANS TERMINAL (3)

TUNER VIDEO

Ref. No.	Part No.	Description	Remark
< FUSE >			
△F951	1-532-749-11	FUSE, GLASS TUBE (8A)	
△F953	1-532-749-11	FUSE, GLASS TUBE (8A)	
△F955	1-576-108-11	FUSE (4A)	
< RELAY >			
RY951	1-515-894-11	RELAY	

*	1-644-273-11	TRANS TERMINAL (3) BOARD (US, CND)	

*	A-4347-954-A	TUNER VIDEO BOARD, COMPLETE (D1090)	
*	A-4347-938-A	TUNER VIDEO BOARD, COMPLETE (D2090)	

< CAPACITOR >			
C1	1-162-294-31	CERAMIC 0.001uF 10% 50V	
C2	1-124-477-11	ELECT 47uF 20% 25V	
C3	1-161-379-00	CERAMIC 0.01uF 20% 25V	
C4	1-162-294-31	CERAMIC 0.001uF 10% 50V	
C5	1-161-379-00	CERAMIC 0.01uF 20% 25V	
C6	1-161-379-00	CERAMIC 0.01uF 20% 25V	
C11	1-164-097-11	CERAMIC 0.022uF 50V	
C21	1-161-021-11	CERAMIC 0.047uF 10% 25V	
C22	1-161-379-00	CERAMIC 0.01uF 20% 25V	
C23	1-124-477-11	ELECT 47uF 20% 25V	
C24	1-123-382-00	ELECT 3.3uF 20% 100V	
C25	1-161-379-00	CERAMIC 0.01uF 20% 25V	
C26	1-161-329-00	CERAMIC 0.0068uF 30% 16V	
C27	1-162-282-31	CERAMIC 100PF 10% 50V	
C28	1-124-903-11	ELECT 1uF 20% 50V	
C30	1-124-903-11	ELECT 1uF 20% 50V	
C31	1-124-902-00	ELECT 0.47uF 20% 50V	
C32	1-124-463-00	ELECT 0.1uF 20% 50V	
C33	1-130-482-00	MYLAR 0.0082uF 5% 50V	
C34	1-123-382-00	ELECT 3.3uF 20% 100V	
C35	1-130-482-00	MYLAR 0.0082uF 5% 50V	
C36	1-123-382-00	ELECT 3.3uF 20% 100V	
C37	1-124-907-11	ELECT 10uF 20% 50V	
C39	1-161-379-00	CERAMIC 0.01uF 20% 25V	
C40	1-124-463-00	ELECT 0.1uF 20% 50V	
C41	1-124-927-11	ELECT 4.7uF 20% 100V	
C42	1-161-379-00	CERAMIC 0.01uF 20% 25V	
C43	1-126-176-11	ELECT 220uF 20% 10V	
C44	1-161-379-00	CERAMIC 0.01uF 20% 25V	
C45	1-123-382-00	ELECT 3.3uF 20% 100V	
C46	1-161-375-00	CERAMIC 0.0022uF 20% 50V	

Ref. No.	Part No.	Description	Remark
C48	1-123-382-00	ELECT 3.3uF 20% 100V	
C49	1-161-375-00	CERAMIC 0.0022uF 20% 50V	
C51	1-124-477-11	ELECT 47uF 20% 25V	
C61	1-161-494-00	CERAMIC 0.022uF 25V	
C63	1-161-494-00	CERAMIC 0.022uF 25V	
C81	1-102-961-00	CERAMIC 27PF 5% 50V	
C82	1-102-961-00	CERAMIC 27PF 5% 50V	
C83	1-161-379-00	CERAMIC 0.01uF 20% 25V	
C84	1-161-379-00	CERAMIC 0.01uF 20% 25V	
C85	1-161-379-00	CERAMIC 0.01uF 20% 25V	
C86	1-124-477-11	ELECT 47uF 20% 25V	
C87	1-161-379-00	CERAMIC 0.01uF 20% 25V	
C88	1-161-379-00	CERAMIC 0.01uF 20% 25V	
C89	1-124-925-11	ELECT 2.2uF 20% 100V	
C90	1-124-463-00	ELECT 0.1uF 20% 50V	
C91	1-161-379-00	CERAMIC 0.01uF 20% 25V	
C92	1-161-379-00	CERAMIC 0.01uF 20% 25V	
C93	1-124-477-11	ELECT 47uF 20% 25V	
C101	1-124-903-11	ELECT 1uF 20% 50V	
C102	1-124-903-11	ELECT 1uF 20% 50V	
C103	1-124-472-11	ELECT 470uF 20% 10V	
C104	1-124-472-11	ELECT 470uF 20% 10V	
C108	1-164-159-11	CERAMIC 0.1uF 50V	
C109	1-124-120-11	ELECT 220uF 20% 25V	
C110	1-124-903-11	ELECT 1uF 20% 50V	
C111	1-124-903-11	ELECT 1uF 20% 50V (D2090)	
C112	1-124-903-11	ELECT 1uF 20% 50V (D2090)	
C113	1-124-903-11	ELECT 1uF 20% 50V (D2090)	
< FILTER >			
CF1	1-567-389-11	FILTER, CERAMIC	
CF2	1-567-389-11	FILTER, CERAMIC	
CF21	1-577-075-11	OSCILLATOR, CERAMIC	
< TRANSFORMER >			
CFT21	1-404-853-11	TRANSFORMER, IF (CERAMIC FILTER)	
< CONNECTOR >			
* CNS1	1-691-183-11	CONNECTOR (BOARD TO BOARD) 13P	
* CNS104	1-568-824-11	SOCKET, CONNECTOR 5P (D2090)	
< DIODE >			
D101	8-719-987-63	DIODE 1N4148M (D2090)	
D102	8-719-987-63	DIODE 1N4148M (D2090)	
< FRONTEND >			
FE1	1-693-201-11	FRONT END, FM	
FE61	1-236-461-11	ENCAPSULATED COMPONENT	

The components identified by mark △ or dotted line with mark △ are critical for safety. Replace only with part number specified.

Les composants identifiés par une marque △ sont critiques pour la sécurité. Ne les remplacer que par une pièce portant le numéro spécifié.

TUNER VIDEO

Ref. No.	Part No.	Description	Remark	Ref. No.	Part No.	Description	Remark
< IC >							
IC10	8-759-821-45	IC LA1851N		R29	1-249-429-11	CARBON 10K 5% 1/4W	
IC11	8-759-820-91	IC LC7218		R31	1-249-413-11	CARBON 470 5% 1/4W	
IC101	8-759-991-77	IC BA7625		R32	1-249-429-11	CARBON 10K 5% 1/4W	
IC102	8-759-056-91	IC BA7611AN		R33	1-249-429-11	CARBON 10K 5% 1/4W	
< JACK >							
J101	1-568-751-51	JACK, PIN (2P SHIELD TYPE)		R35	1-249-437-11	CARBON 47K 5% 1/4W	
J102	1-568-751-51	JACK, PIN (2P SHIELD TYPE)		R37	1-247-891-00	CARBON 330K 5% 1/4W	
< COIL >							
L1	1-410-521-11	INDUCTOR 100uH		R39	1-249-423-11	CARBON 3.3K 5% 1/4W	
L21	1-410-171-11	INDUCTOR 1mH		R40	1-249-420-11	CARBON 1.8K 5% 1/4W	
< FILTER >							
LPF21	1-235-221-00	FILTER, LOW PASS		R41	1-249-426-11	CARBON 5.6K 5% 1/4W	
< TRANSISTOR >							
Q1	8-729-230-XX	TRANSISTOR 2SC2669-OY		R42	1-247-891-00	CARBON 330K 5% 1/4W	
Q2	8-729-230-XX	TRANSISTOR 2SC2669-OY		R44	1-249-423-11	CARBON 3.3K 5% 1/4W	
Q21	8-729-119-78	TRANSISTOR 2SC2785-HFE		R45	1-249-420-11	CARBON 1.8K 5% 1/4W	
Q22	8-729-119-78	TRANSISTOR 2SC2785-HFE		R46	1-249-426-11	CARBON 5.6K 5% 1/4W	
Q23	8-729-900-61	TRANSISTOR DTA114ES		△R47	1-249-409-11	CARBON 220 5% 1/4W F	
Q24	8-729-900-36	TRANSISTOR DTC124ES		R61	1-249-441-11	CARBON 100K 5% 1/4W	
Q25	8-729-900-36	TRANSISTOR DTC124ES		R62	1-249-437-11	CARBON 47K 5% 1/4W	
Q81	8-729-900-61	TRANSISTOR DTA114ES		R63	1-249-397-11	CARBON 22 5% 1/4W	
Q82	8-729-900-36	TRANSISTOR DTC124ES		R64	1-249-417-11	CARBON 1K 5% 1/4W	
Q83	8-729-202-67	TRANSISTOR 2SK246-GR3		R70	1-249-423-11	CARBON 3.3K 5% 1/4W	
Q84	8-729-230-93	TRANSISTOR 2SC3113-AB		R71	1-249-414-11	CARBON 560 5% 1/4W	
Q101	8-729-119-76	TRANSISTOR 2SA1175-HFE		R72	1-249-417-11	CARBON 1K 5% 1/4W	
Q102	8-729-119-76	TRANSISTOR 2SA1175-HFE		R73	1-249-410-11	CARBON 270 5% 1/4W	
< RESISTOR >							
△R1	1-249-407-11	CARBON 150 5% 1/4W	F	R74	1-249-425-11	CARBON 4.7K 5% 1/4W	
R3	1-249-411-11	CARBON 330 5% 1/4W		R75	1-249-421-11	CARBON 2.2K 5% 1/4W	
R4	1-249-411-11	CARBON 330 5% 1/4W		R76	1-249-425-11	CARBON 4.7K 5% 1/4W	
R5	1-249-411-11	CARBON 330 5% 1/4W		R77	1-249-405-11	CARBON 100 5% 1/4W	
R6	1-249-432-11	CARBON 18K 5% 1/4W		R78	1-249-425-11	CARBON 4.7K 5% 1/4W	
R7	1-249-411-11	CARBON 330 5% 1/4W		△R79	1-249-407-11	CARBON 150 5% 1/4W F	
R8	1-249-414-11	CARBON 560 5% 1/4W		R81	1-249-417-11	CARBON 1K 5% 1/4W	
R9	1-249-434-11	CARBON 27K 5% 1/4W		R82	1-249-417-11	CARBON 1K 5% 1/4W	
△R21	1-249-405-11	CARBON 100 5% 1/4W	F	R83	1-249-417-11	CARBON 1K 5% 1/4W	
R22	1-249-428-11	CARBON 8.2K 5% 1/4W		R84	1-249-417-11	CARBON 1K 5% 1/4W	
R23	1-249-417-11	CARBON 1K 5% 1/4W		R85	1-249-429-11	CARBON 10K 5% 1/4W	
R24	1-249-435-11	CARBON 33K 5% 1/4W		R86	1-249-417-11	CARBON 1K 5% 1/4W	
R25	1-249-428-11	CARBON 8.2K 5% 1/4W		R87	1-249-429-11	CARBON 10K 5% 1/4W	
R27	1-249-432-11	CARBON 18K 5% 1/4W		R88	1-249-425-11	CARBON 4.7K 5% 1/4W	
R28	1-249-423-11	CARBON 3.3K 5% 1/4W		R89	1-249-417-11	CARBON 1K 5% 1/4W	
				R91	1-249-417-11	CARBON 1K 5% 1/4W	
				△R92	1-249-401-11	CARBON 47 5% 1/4W F	
				R101	1-247-804-11	CARBON 75 5% 1/4W	
				R102	1-247-804-11	CARBON 75 5% 1/4W	
				R103	1-247-804-11	CARBON 75 5% 1/4W	
				R104	1-249-429-11	CARBON 10K 5% 1/4W	
				R105	1-247-804-11	CARBON 75 5% 1/4W	
				R106	1-249-429-11	CARBON 10K 5% 1/4W	
				R109	1-249-405-11	CARBON 100 5% 1/4W	
				R110	1-249-405-11	CARBON 100 5% 1/4W	
				R113	1-249-405-11	CARBON 100 5% 1/4W	
				R114	1-249-405-11	CARBON 100 5% 1/4W	

The components identified by mark △ or dotted line with mark △ are critical for safety. Replace only with part number specified.

Les composants identifiés par une marque △ sont critiques pour la sécurité. Ne les remplacer que par une pièce portant le numéro spécifié.

TUNER VIDEO

Ref. No.	Part No.	Description	Remark
R115	1-249-433-11	CARBON	22K 5% 1/4W
R116	1-249-433-11	CARBON	22K 5% 1/4W
R117	1-249-433-11	CARBON	22K 5% 1/4W
R120	1-249-425-11	CARBON	4.7K 5% 1/4W (D2090)
R121	1-249-425-11	CARBON	4.7K 5% 1/4W (D2090)
< VARIABLE RESISTOR >			
RV21	1-241-628-11	RES, ADJ, CARBON	2.2K
RV22	1-241-631-11	RES, ADJ, CARBON	22K
RV24	1-241-631-11	RES, ADJ, CARBON	22K
RV25	1-241-631-11	RES, ADJ, CARBON	22K
< TRANSFORMER >			
T21	1-404-807-11	TRANSFORMER, DISCRIMINATOR	
< TERMINAL >			
* TM1	1-562-907-11	CONNECTOR, F-J (ANTENNA:FM)	
TM2	1-536-707-00	TERMINAL BOARD, PUSH 2P (ANTENNA:AM)	
< TEST PIN >			
* TP1	1-560-060-00	PIN, CONNECTOR 2P	
< VIBRATOR >			
XT81	1-577-126-11	VIBRATOR, CRYSTAL 7.2MHz	

MISCELLANEOUS			

16	1-690-091-11	WIRE, FLAT TYPE (21 CORE)	
△58	1-575-975-11	CORD, POWER (US, CND)	
△58	1-590-074-11	CORD, POWER (E)	
62	1-575-777-11	WIRE, FLAT TYPE (5 CORE) (D2090)	
63	1-690-421-11	WIRE, FLAT TYPE (7 CORE) (D2090)	
64	1-696-073-21	LEAD (WITH CONNECTOR) (2 CORE) (US, CND)	
△65	1-569-007-11	ADAPTER, CONVERSION 2P (E)	
110	1-575-848-11	WIRE, FLAT TYPE (5 CORE)	
111	1-696-550-11	WIRE (FLAT TYPE) (33 CORE)	
△F901	1-532-350-00	FUSE (4A) (E)	
△F901	1-576-108-11	FUSE (4A) (US, CND)	
△F902	1-532-350-00	FUSE (4A) (E)	
△F902	1-532-749-11	FUSE, GLASS TUBE (8A) (US, CND)	
△F903	1-532-350-00	FUSE (4A) (E)	
△F904	1-532-350-00	FUSE (4A) (E)	
△F951	1-532-749-11	FUSE, GLASS TUBE (8A)	
△F953	1-532-749-11	FUSE, GLASS TUBE (8A)	
△F955	1-576-108-11	FUSE (4A)	

Ref. No.	Part No.	Description	Remark
△F957	1-576-109-11	FUSE (5A)	
△F959	1-576-109-11	FUSE (5A)	
Q657	8-729-209-15	TRANSISTOR 2SD2012	
Q664	8-729-321-24	TRANSISTOR 2SA1672-OY	
Q665	8-729-321-21	TRANSISTOR 2SC4387-OY	
Q702	8-729-209-15	TRANSISTOR 2SD2012	
Q705	8-729-320-96	TRANSISTOR 2SC2921-OPY	
Q709	8-729-320-73	TRANSISTOR 2SA1215-OY	
Q752	8-729-209-15	TRANSISTOR 2SD2012	
Q755	8-729-320-96	TRANSISTOR 2SC2921-OPY	
Q759	8-729-320-73	TRANSISTOR 2SA1215-OY	
△T902	1-697-009-11	TRANSFORMER, POWER (US)	
△T902	1-697-010-11	TRANSFORMER, POWER (CND)	
△T902	1-697-011-11	TRANSFORMER, POWER (E)	

ACCESSORIES & PACKING MATERIALS

1-501-374-11	ANTENNA, LOOP
1-693-098-11	COMMANDER, STANDARD (RM-P321) (D2090/D1090:E)
1-693-099-11	COMMANDER, STANDARD (RM-U221) (D1090:US, CND)
3-755-227-21	MANUAL, INSTRUCTION (ENGLISH)
3-755-227-31	MANUAL, INSTRUCTION (FRENCH) (CND)
4-925-079-01	COVER (6), BATTERY
* 4-927-854-01	CUSHION
* 4-954-571-01	INDIVIDUAL CARTON (D2090)
* 4-954-572-01	INDIVIDUAL CARTON (D1090)
9-910-999-33	INSTRUCTION (US)

HARDWARE LIST

#1	7-685-646-79	SCREW +BVTP 3X8 TYPE2 IT-3
#2	7-682-547-04	SCREW +BVTT 3X6 (S)
#3	7-682-561-04	SCREW +BVTT 4X8 (S)
#4	7-685-648-79	SCREW +BVTP 3X12 TYPE2 IT-3

<p>The components identified by mark △ or dotted line with mark. △ are critical for safety. Replace only with part number specified.</p>	<p>Les composants identifiés par une marque △ sont critiques pour la sécurité. Ne les remplacer que par une pièce portant le numéro spécifié.</p>
--	---

STR-D1090 / D2090

SONY[®] SERVICE MANUAL

US Model
Canadian Model
E Model
STR-D1090

US Model
Canadian Model
STR-D2090

SUPPLEMENT-1

File this Supplement with the Service Manual.

Subject : Block diagram

• BLOCK DIAGRAM 1

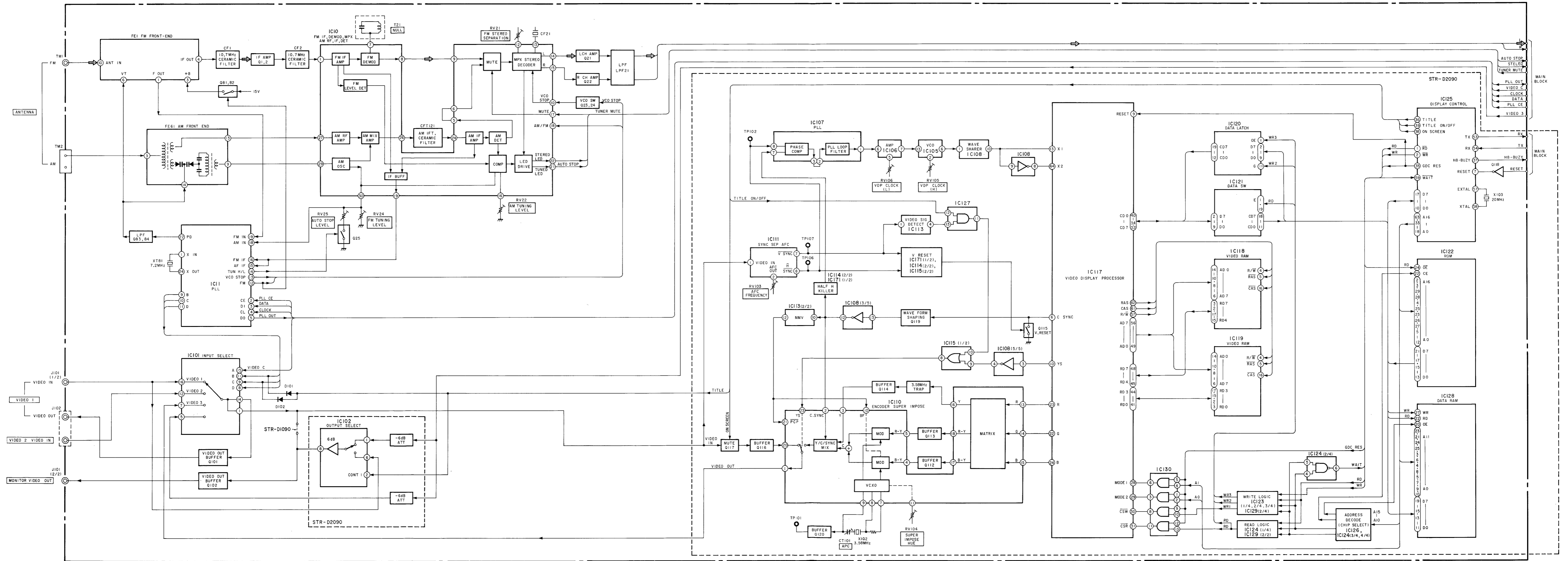

BLOCK DIAGRAM 2

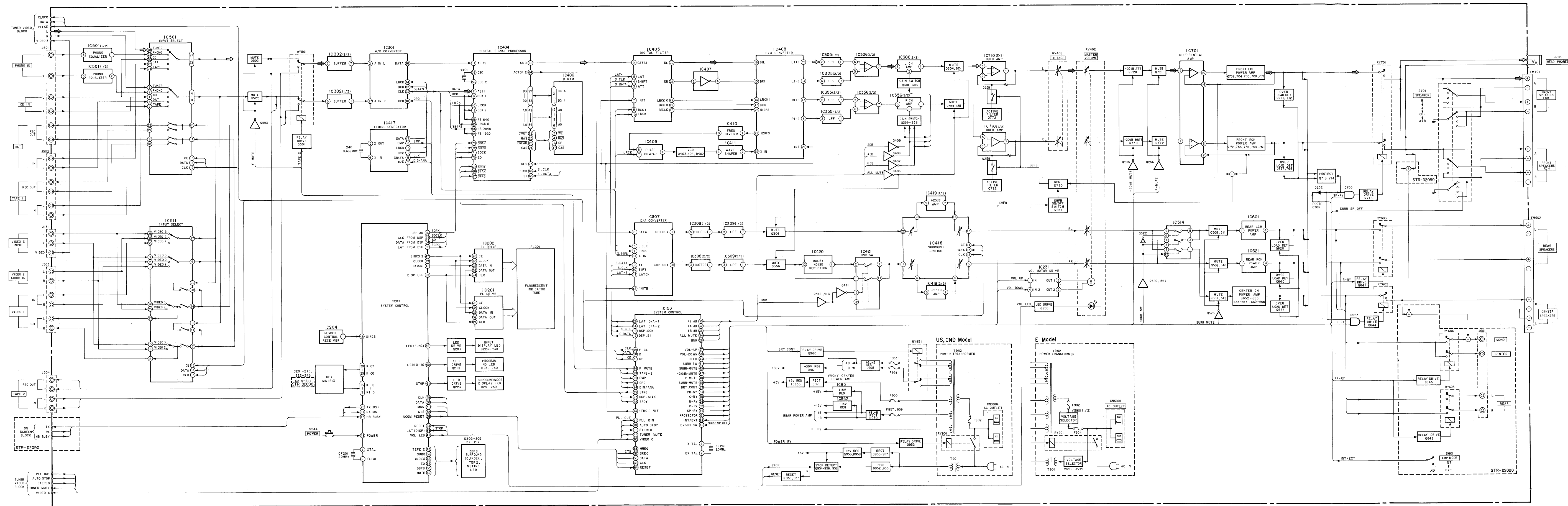

STR-D1090/D2090

SONY[®] SERVICE MANUAL

US Model
Canadian Model
E Model
STR-D1090

SUPPLEMENT-2

US Model
Canadian Model
STR-D2090

File this Supplement with the Service Manual.

Subject:

1. Addition of IC710 on A CLASS board
2. Change of SURROUND board
3. Correction of semiconductor lead layouts

1. Addition of IC710 on A CLASS board.

 : Added portion

• 4-5. SCHEMATIC DIAGRAM — MAIN Section — (Service Manual Page 23.)

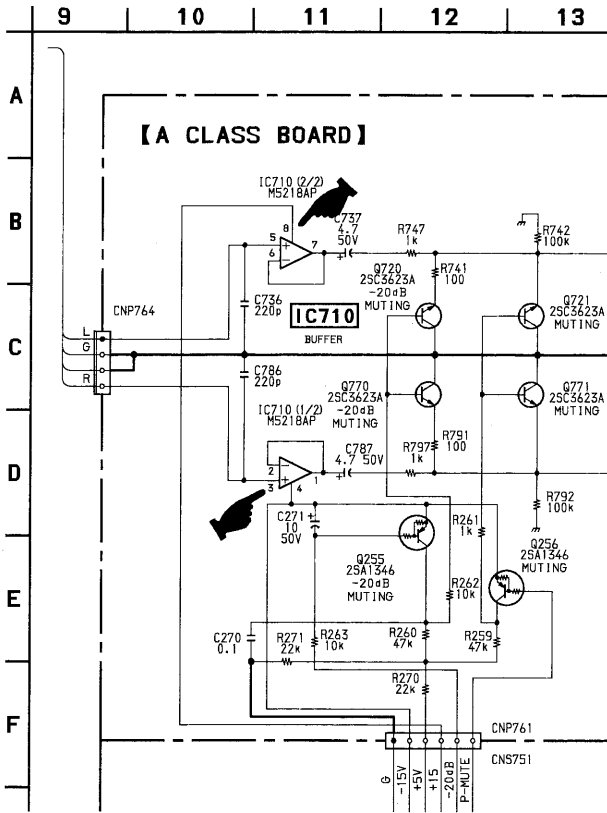

• 4-6. PRINTED WIRING BOARDS — MAIN Section — (Service Manual Page 28.)

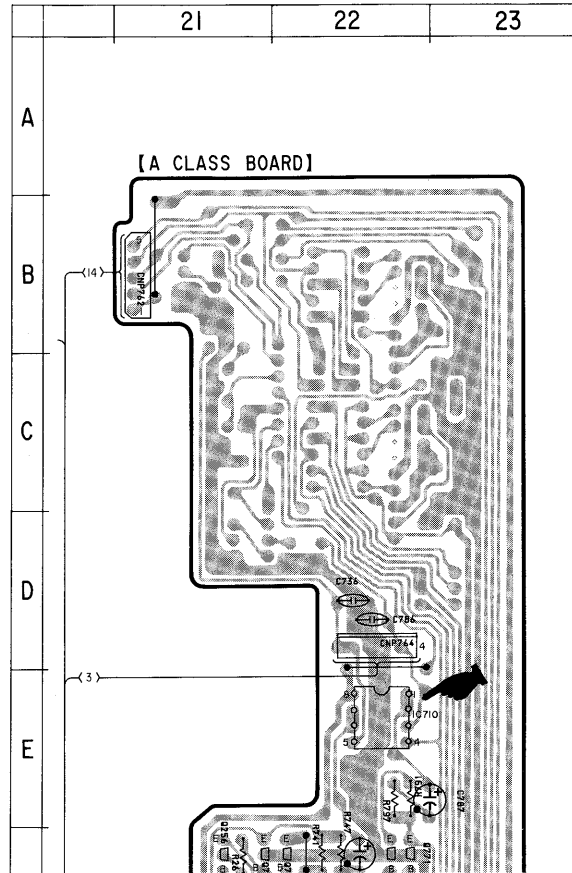

• SECTION 6. ELECTRICAL PARTS LIST

Page	INCORRECT		CORRECT	
	Ref. No.	Part No.	Description	
55				IC710 8-759-634-51 IC M5218AP 

2. Change of SURROUND board.

• 4-7. SCHEMATIC DIAGRAM — DIGITAL Section — (Service Manual Page 32.)

➔ : Added and changed portion

1 2 3 4 5 6 7 8 9 10 11 12 13 14 15 16 17 18 19 20 21 22 23

A
B
C
D
E
F
G
H
I
J
K
L
M
N
O
P

[SURROUND BOARD]

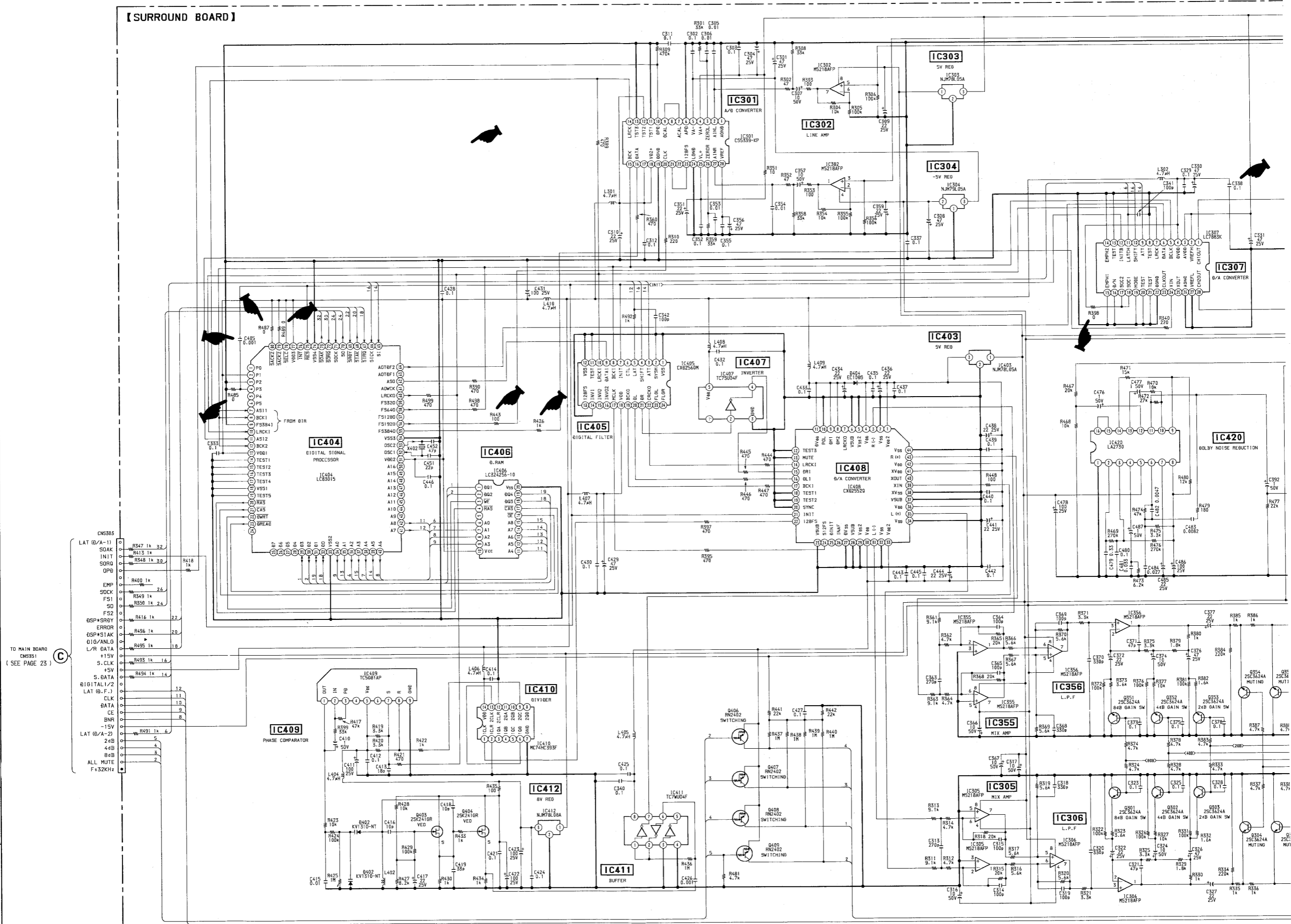

• SECTION 6. ELECTRICAL PARTS LIST (SURROUND board)
(Service Manual Page 67—71.)

Page	Ref. No.	Former Parts			New Parts		
		Part No.	Description	Part No.	Description		
67	C338	_____		1-164-004-11	CERAMIC CHIP	0.1uF	10% 25V
68	C405	_____		1-163-009-11	CERAMIC CHIP	0.001uF	10% 50V
	C462	1-124-477-11	ELECT 47uF 20% 25V	_____			
	C463	1-164-004-11	CERAMIC CHIP 0.1uF 10% 25V	_____			
	C464	1-130-481-00	MYLAR 0.0068uF 5% 50V	_____			
	C465	1-163-235-11	CERAMIC CHIP 22PF 5% 50V	_____			
	C466	1-163-235-11	CERAMIC CHIP 22PF 5% 50V	_____			
69	IC408	8-752-335-52	IC CXD2552Q-2	8-752-334-87	IC CXD2552Q		
	IC410	8-759-926-74	IC SN74HC393ANS	8-759-013-94	IC MC74HC393F		
	L413	1-410-377-31	INDUCTOR CHIP 4.7uH	_____			
70	R357	1-216-041-00	METAL CHIP 470 5% 1/10W	_____			
	R398	_____		1-216-295-00	METAL CHIP	0 5% 1/10W	
	R401	1-216-041-00	METAL CHIP 470 5% 1/10W	_____			
	R414	1-216-049-00	METAL CHIP 1K 5% 1/10W	_____			
	R426	1-216-295-00	METAL CHIP 0 5% 1/10W	1-216-049-00	METAL CHIP	1K 5% 1/10W	
71	R443	1-216-025-00	METAL CHIP 100 5% 1/10W	1-216-049-00	METAL CHIP	1K 5% 1/10W	
	R463	1-216-029-00	METAL CHIP 150 5% 1/10W	_____			
	R464	1-216-025-00	METAL CHIP 100 5% 1/10W	_____			
	R465	1-216-121-00	METAL CHIP 1M 5% 1/10W	_____			
	R478	1-216-041-00	METAL CHIP 470 5% 1/10W	_____			
	R486	1-216-295-00	METAL CHIP 0 5% 1/10W	_____			
	R487	_____		1-216-295-00	METAL CHIP	0 5% 1/10W	
	R488	1-216-295-00	METAL CHIP 0 5% 1/10W	_____			
	R489	_____		1-216-295-00	METAL CHIP	0 5% 1/10W	
	X401	1-577-269-11	VIBRATOR, CRYSTAL 18.432MHz	_____			

3. Correction of semiconductor lead layouts.

- SEMICONDUCTOR LEAD LAYOUTS
(Service Manual Page 13.)

 : Corrected portion

