

STR-A27/D209/D259

SERVICE MANUAL

STR-A27, STR-D209 and STR-259 are the tuner and amplifier section in LBT-A27CDM, LBT-D209CD and LBT-D259CD respectively.

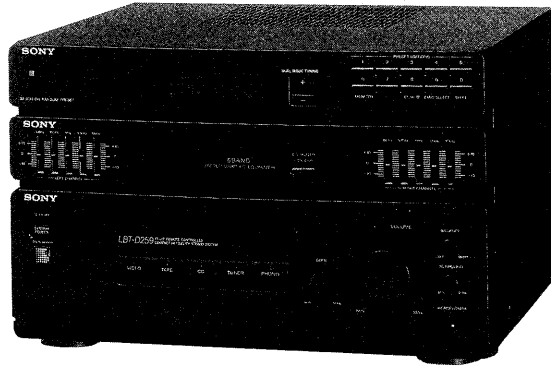

PHOTO: STR - D259

Canadian Model
STR-D259

AEP Model

UK Model

STR-D209/D259

E Model

Australian Model

STR-A27

SPECIFICATIONS

Stereo FM-AM receiver

Tuner

System FM stereo
FM/AM superheterodyne tuner

FM tuner section

Tuning range 87.5 to 108 MHz (EXCEPT EE)
65.0 to 74.0 MHz (EE)

Antenna 75 ohms unbalanced

Intermediate frequency 10.7 MHz

AM tuner section

Tuning range MW:530 to 1710 kHz (Canadian model)
522 to 1611 kHz (Italian model)
531 to 1602 kHz (9 kHz step) } (E model)
531 to 1710 kHz (10 kHz step)
531 to 1602 kHz (Other models)

LW:153 to 279 kHz
SW:5.95 to 17.90 kHz (Mideasten model)

Antenna AM loop antenna
External antenna terminal

Intermediate frequency 450 kHz

Amplifier

DIN power output 30 W + 30 W (6 ohms, at 1 kHz)

Continuous RMS power output 35 W + 35 W (6 ohms, at 1 kHz, 5% THD)

Music power output 60 W + 60 W (6 ohms)

Input	Jack type	Sensitivity	Impedance
VIDEO IN	Phono	300 mV	47 kohms
PHONO IN	Phono	3 mV	47 kohms

Output	Jack type	Impedance
SURROUND SPEAKER	Phono	Accepts speakers of 16 ohms
HEADPHONES	Stereophone	Accepts headphones of 8 ohms or more

Frequency response VIDEO: 15 Hz to 50 kHz $^{+0}_{-3}$ dB

General

Power requirements 220 - 230 V AC, 50/60 Hz (AEP, IT, EE, G)
120 V AC, 60 Hz (CND)
240 V-AC, 50 Hz (UK)
110 - 120 V/220 - 240 V-AC,
50 Hz/60 Hz (E, AUS)

Power consumption 100 W (AEP, AE2, IT, EE, G, UK)
115 W (CND)
170 W (E, AUS, AU2)

Mass Approx. 5.9 kg

Dimensions Approx. 355 × 225 × 330 mm
(w/h/d, including projections)

STEREO FM-AM RECEIVER
SONY®

TABLE OF CONTENTS

— MODEL IDENTIFICATION —

(Specification Label)

STR-A27, STR-D209, STR-D259

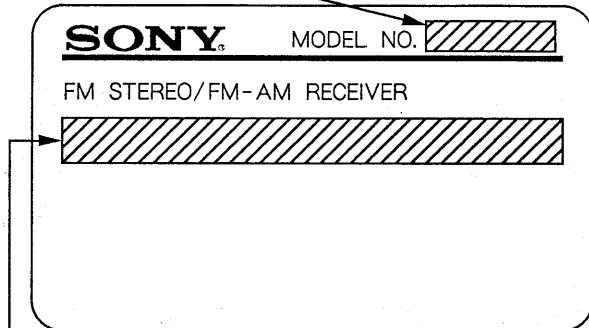



- CND model : AC : 120V 60Hz 115W
- AEP, IT, EE, G model : AC : 220V-230V~50/60Hz
100W
- UK model : AC : 240V~50Hz 100W
- E, AUS model : AC : 110-120V/220-
240V~50/60Hz 170W

Note : CND : Canadian model
 G : German
 IT : Italian model
 EE : East European model
 AUS, AU2 : Australian model

● CAUTION

Be sure to use insulation sheet (A4-959-364-01) when replacing power transformer because it is safely related part.

SAFETY-RELATED COMPONENT WARNING!!

COMPONENTS IDENTIFIED BY MARK  OR DOTTED LINE WITH MARK  ON THE SCHEMATIC DIAGRAMS AND IN THE PARTS LIST ARE CRITICAL TO SAFE OPERATION. REPLACE THESE COMPONENTS WITH SONY PARTS WHOSE PART NUMBERS APPEAR AS SHOWN IN THIS MANUAL OR IN SUPPLEMENTS PUBLISHED BY SONY.

<u>Section</u>	<u>Title</u>	<u>Page</u>
1. GENERAL	3
2. DISASSEMBLY		
2-1. Front Panel	4
2-2. Panel Board	4
2-3. Amplifier Board	5
2-4. Main/Tuner Board	5
3. ADJUSTMENT	6
4. DIAGRAMS		
4-1. Schematic Diagram — Tuner Section —	7
4-2. Printed Wiring Board — Main Section —	11
4-3. Schematic Diagram — Main Section —	15
4-4. Schematic Diagram — Display Section —	19
4-5. Printed Wiring Board — Display Section —	23
4-6. Circuit Boards Location	26
4-7. Semiconductor Lead Layouts	26
5. EXPLODED VIEWS		
5-1. Front Section	27
5-2. Back Panel Section	29
6. ELECTRICAL PARTS LIST	30

ATTENTION AU COMPOSANT AYANT RAPPORT À LA SÉCURITÉ!

LES COMPOSANTS IDENTIFIÉS PAR UNE MARQUE  SUR LES DIAGRAMMES SCHÉMATIQUES ET LA LISTE DES PIÈCES SONT CRITIQUES POUR LA SÉCURITÉ DE FONCTIONNEMENT. NE REMPLACER CES COMPOSANTS QUE PAR DES PIÈCES SONY DONT LES NUMÉROS SONT DONNÉS DANS CE MANUEL OU DANS LES SUPPLÉMENTS PUBLIÉS PAR SONY.

SECTION 1 GENERAL

This section is extracted from instruction manual.

Location of Controls

Refer to the pages indicated in parentheses for details.

Tuner

- 1 Display window
- 2 DUAL MODE TUNING + / - buttons (20, 22)
- 3 MEMORY button (22)
- 4 Numeric buttons (22)
- 5 SHIFT button (22)
- 6 BAND SELECT button (20)
- 7 ST/MUTE button (20,22)

Graphic Equalizer

- 8 5 BAND GRAPHIC EQUALIZER controls (16)
- 9 EQUALIZER switch (16)

Amplifier

- 10 SYSTEM POWER button (14)
- 11 Function selectors and indicators (VIDEO/TAPE/CD/TUNER/PHONO)
- 12 BALANCE control (16)
- 13 SURROUND control (16)
- 14 HEADPHONES jack
- 15 VOLUME control and indicator (16)
- 16 DBFB (dynamic bass feedback) control (16)

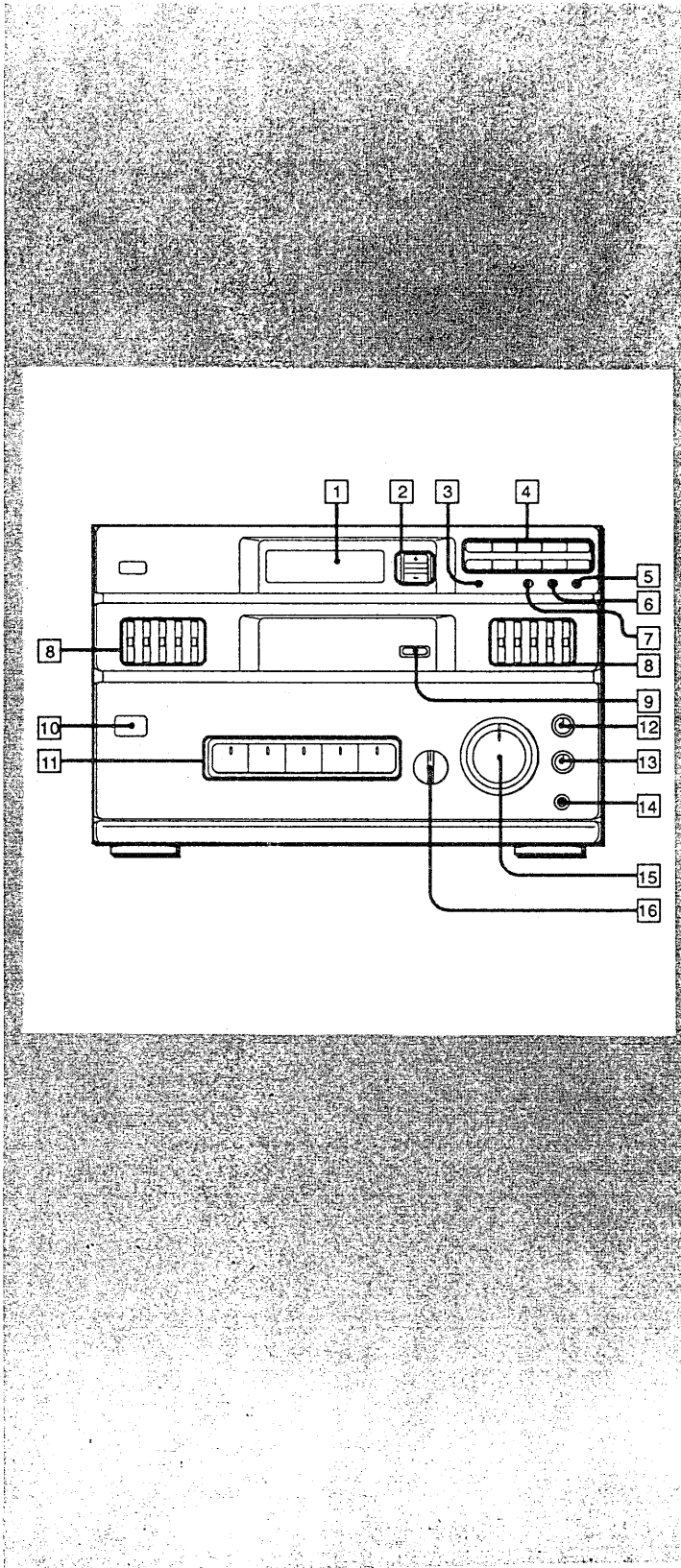

SECTION 2 DISASSEMBLY

NOTE: Follow the disassembly procedure in the numerical order given.

2-1. FRONT PANEL

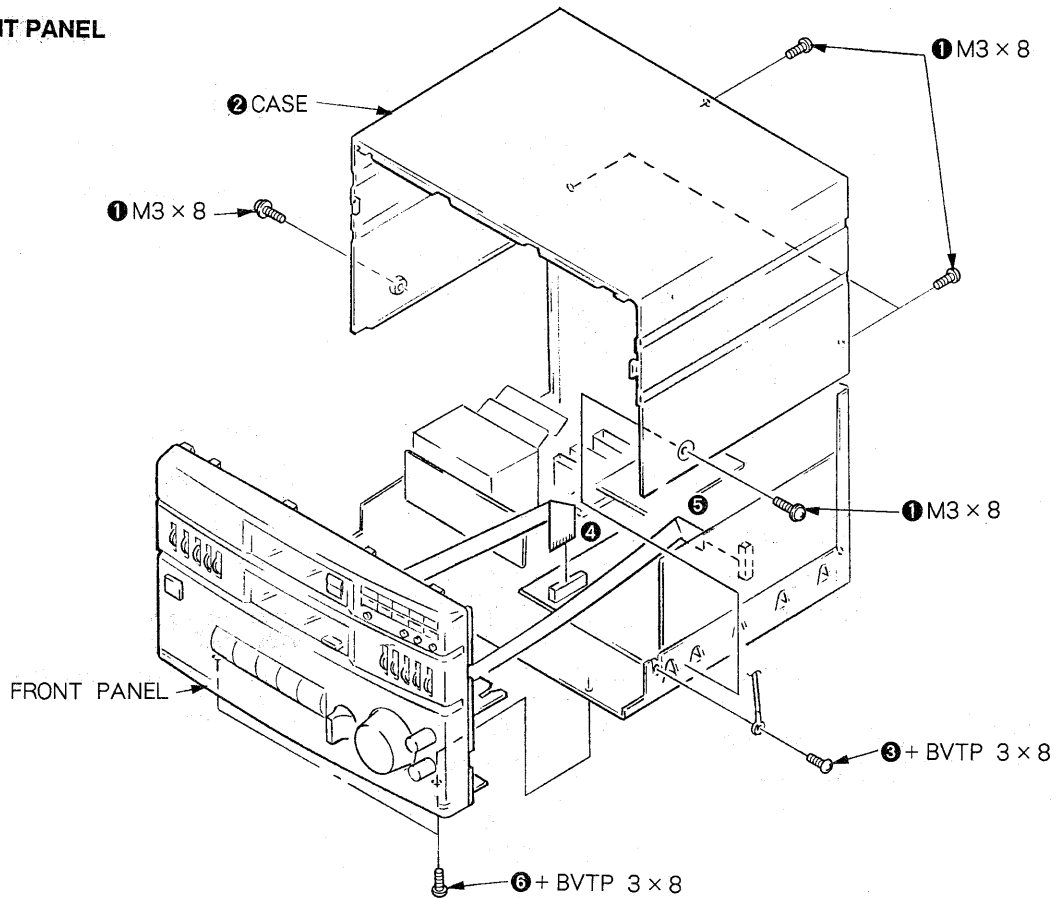

2-2. PANEL BOARD

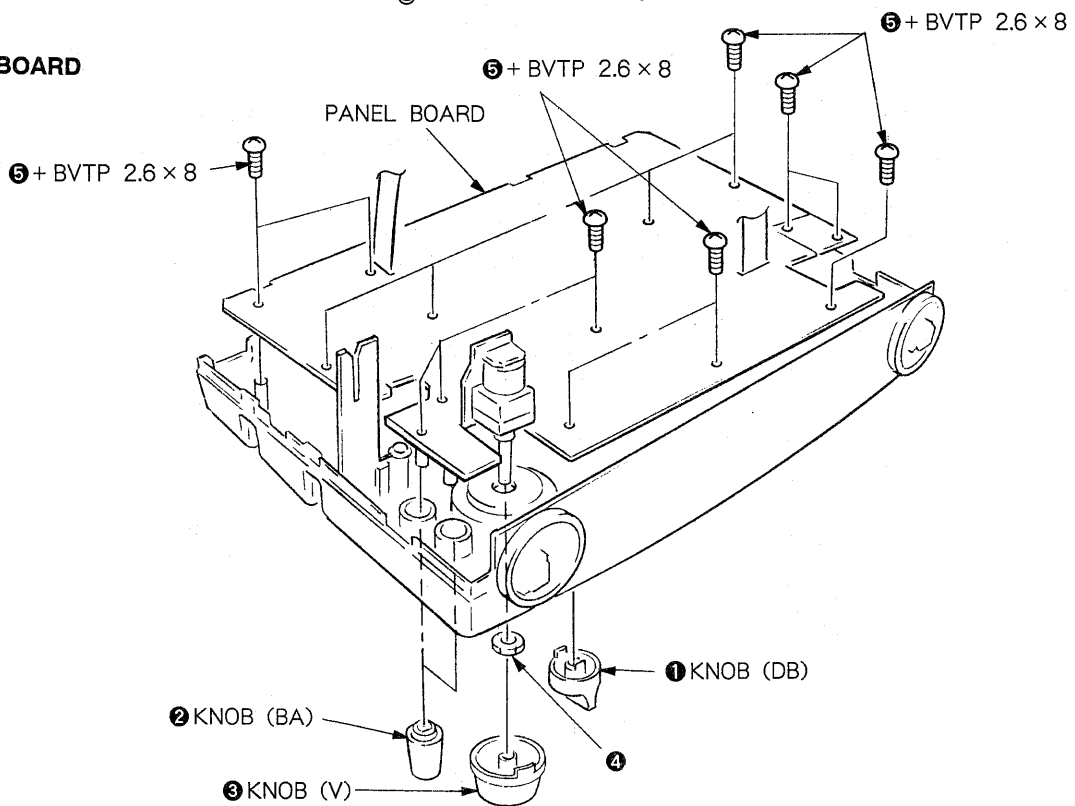

2-3. POWER AMPLIFIER BOARD

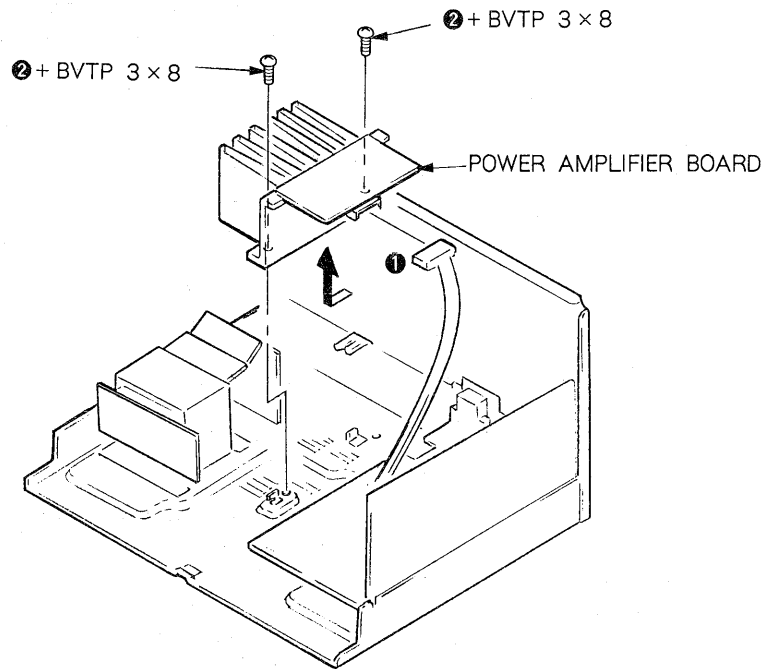

2-4. MAIN /TUNER BOARD

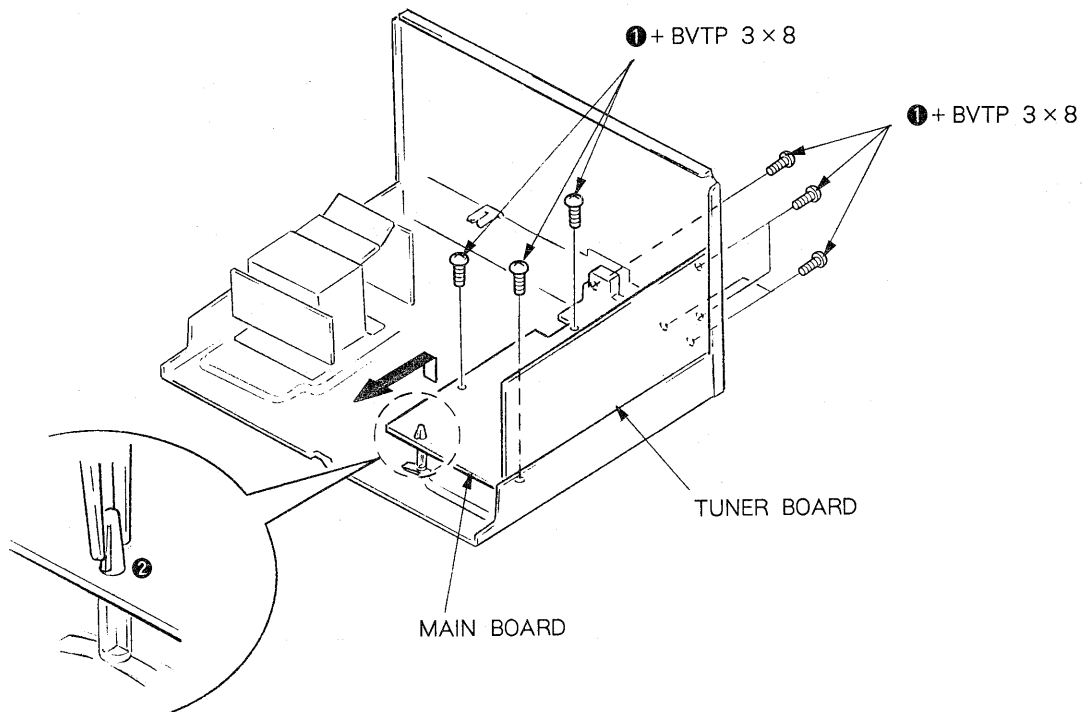

SECTION 3 ADJUSTMENTS

Note: As a front-end (FE301) is difficult to repair if faulty, replace it with new one.

TUNER SECTION

FM SECTION ADJUSTMENTS

Setting :

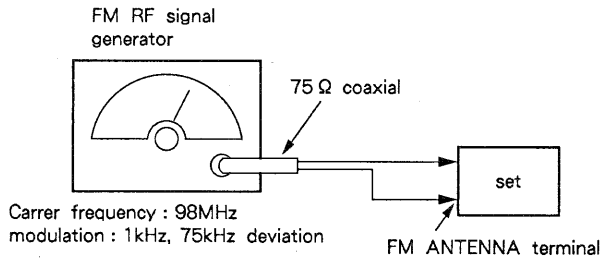

• TUNER OUT CHECK POINT

Speaker out receive 98MHz 60dB μ (1mV) and set the SPEAKER out to 10dBs by VOLUME.

Speaker load : 6 Ω both CH

FM NULL Adjustment

Procedure :

1. Supply a 60dB μ (1mV) 98MHz signal from the ANTENNA terminal.
2. Tune the set to 98MHz.
3. Adjust T301 for 0V reading on the measurement point.

FM Tuned Indication Lighting Level Adjustment

Band : FM

ST/MUTE SW : OFF

Procedure :

1. Supply a $24 \pm 1 \mu V$ ($20 \pm 4dB\mu$ (EE)) ($25 \pm 4dB\mu$ (EXCEPT EE)) 98MHz signal from the ANTENNA terminal.
2. Tune the set to 98MHz.
3. Adjust RV302 so that the FL601 **TUNED** light up.

Adjustment Location: main board

- Repeat the procedures in each adjustment several times, and the frequency coverage and tracking adjustments should be finally done by trimmer capacitors.

AM SECTION ADJUSTMENT

Setting :

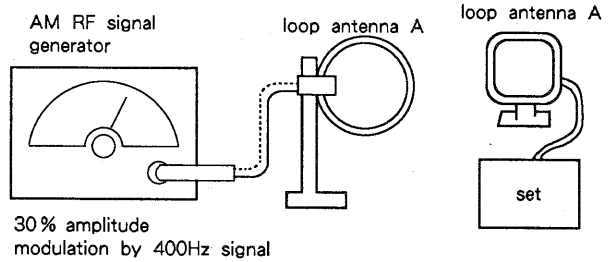

AM Tuned Indication Lighting Level Adjustment

Band : AM

Procedure :

1. Set loop antenna input level to 94dB μ /m, 1050 kHz and no signal tuned light should not on.
2. Tune the set to 1050kHz
3. Adjust RV301 so that the FL601 **TUNED** light up.

Adjustment Location: tuner board

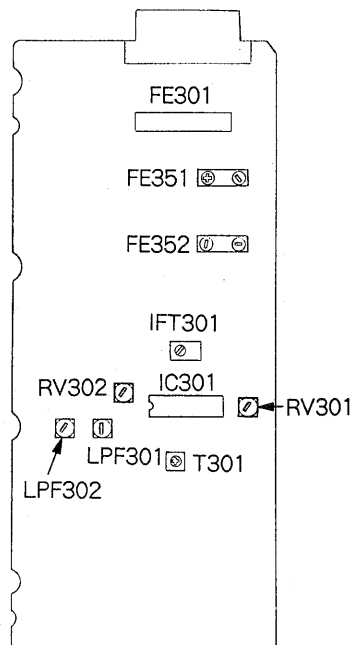

• Semiconductor Location

Ref. No.	Location	Ref. No.	Location
D351 (B)	E-6	IC1306	C-12
D1201	E-19	IC1601	J-19
D1202	E-15		
D1203	E-15	Q301 (E)	D-3
D1204	G-15	Q302 (E)	D-3
D1205	C-14	Q303 (E)	E-3
D1251	G-19	Q303 (B)	E-7
D1302	E-12	Q304 (E)	E-3
D1303	E-12	Q304 (B)	E-7
D1304	E-12	Q305 (E)	I-3
D1305	E-13	Q305 (B)	I-7
D1306	E-13	Q306 (E)	I-3
D1307	J-23	Q306 (B)	I-7
D1309	I-23	Q307 (E)	H-4
D1311	I-24	Q307 (B)	H-4
D1316	H-12	Q308 (E)	H-4
D1317	J-12	Q308 (B)	H-8
D1318	D-13	Q309 (E)	H-4
D1319	D-14	Q309 (B)	H-9
D1321	B-27	Q351 (B)	D-7
D1322	C-27	Q352 (B)	D-7
D1323	E-13	Q353 (B)	E-7
D1324	E-13	Q354 (B)	E-7
D1341	I-14	Q355 (B)	E-6
D1345	I-13	Q356 (B)	E-7
D1347	J-16	Q501 (E)	F-1
D1354	B-25	Q501 (B)	F-6
D1355	B-25	Q502 (E)	F-1
D1368	D-14	Q502 (B)	F-6
D1369	D-13	Q521 (E)	C-4
D1370	J-24	Q521 (B)	C-9
		Q522 (E)	B-4
IC301 (E)	G-2	Q522 (B)	B-9
IC301 (B)	G-7	Q531 (B)	D-8
IC501 (E)	E-4	Q532 (B)	C-9
IC501 (B)	E-9	Q1201	E-19
IC1001	D-11	Q1202	H-18
IC1002	G-11	Q1203	H-18
IC1003	I-11	Q1204	H-15
IC1201	F-20	Q1251	G-19
IC1202	F-15	Q1301	J-23
IC1302	J-12	Q1302	J-13
IC1303	I-14	Q1304	I-15
IC1304	H-13	Q1305	I-15
IC1305	H-14		

(B) : ★ B

(E) : EXCEPT ★ B

Note on Mounting Diagram :

- : Parts extracted from the component side.
- : Pattern on the side which is seen.

• Model name and destination shown by * 1 to * 11.

- * 1 : A27 : Australian
- * 2 : A27 : E, AU2
- * 3 : D209 : UK
- * 4 : D209 : Italian
- * 5 : D209 : East European
- * 6 : D209 : German
- * 7 : D209 : AEP, AE2
- * 8 : D259 : Italian
- * 9 : D259 : AEP, AE2
- * 10 : D259 : UK
- * 11 : D259 : Canadian
- ★ A : * 4, 6, 8
- ★ B : * 3, 5, 7, 9, 10
- ★ C : 209 : AEP, * 3, 6, D259 : AEP, * 10

AU2 : AUS (with in PHONO MODEL)
AE2 : AEP (with in PHONO MODEL)

4-2. PRINTED WIRING BOARD—MAIN SECTION—

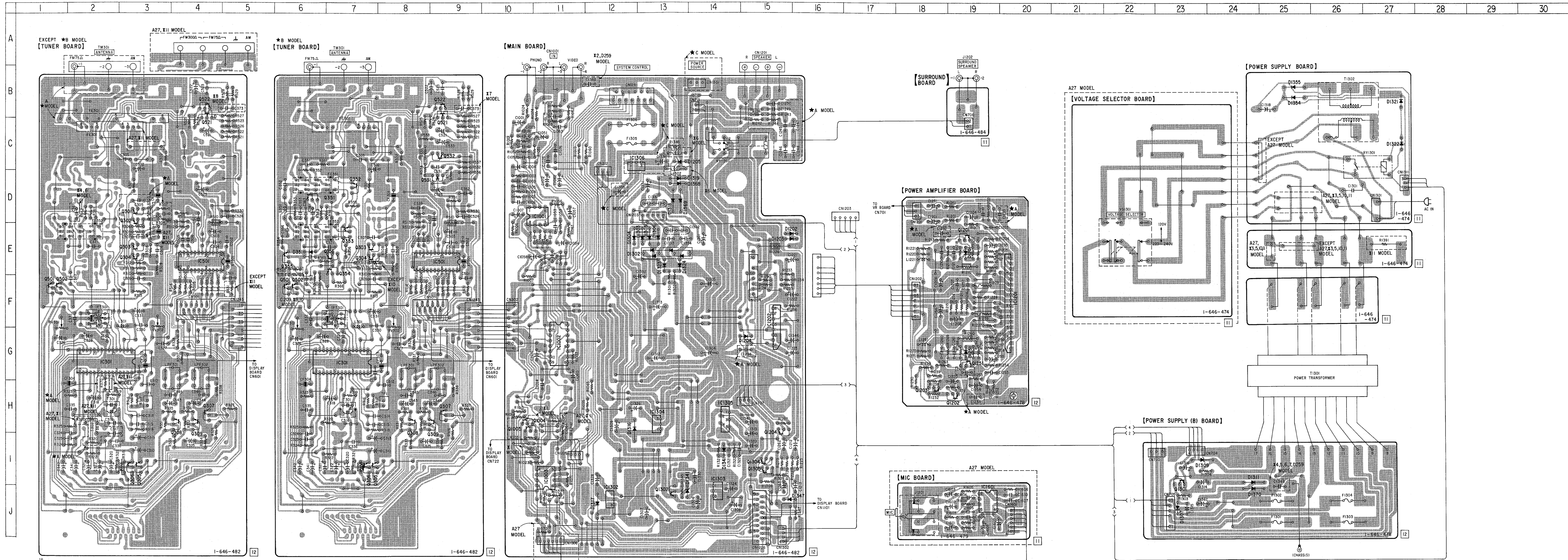

4-4. SCHEMATIC DIAGRAM — DISPLAY SECTION —

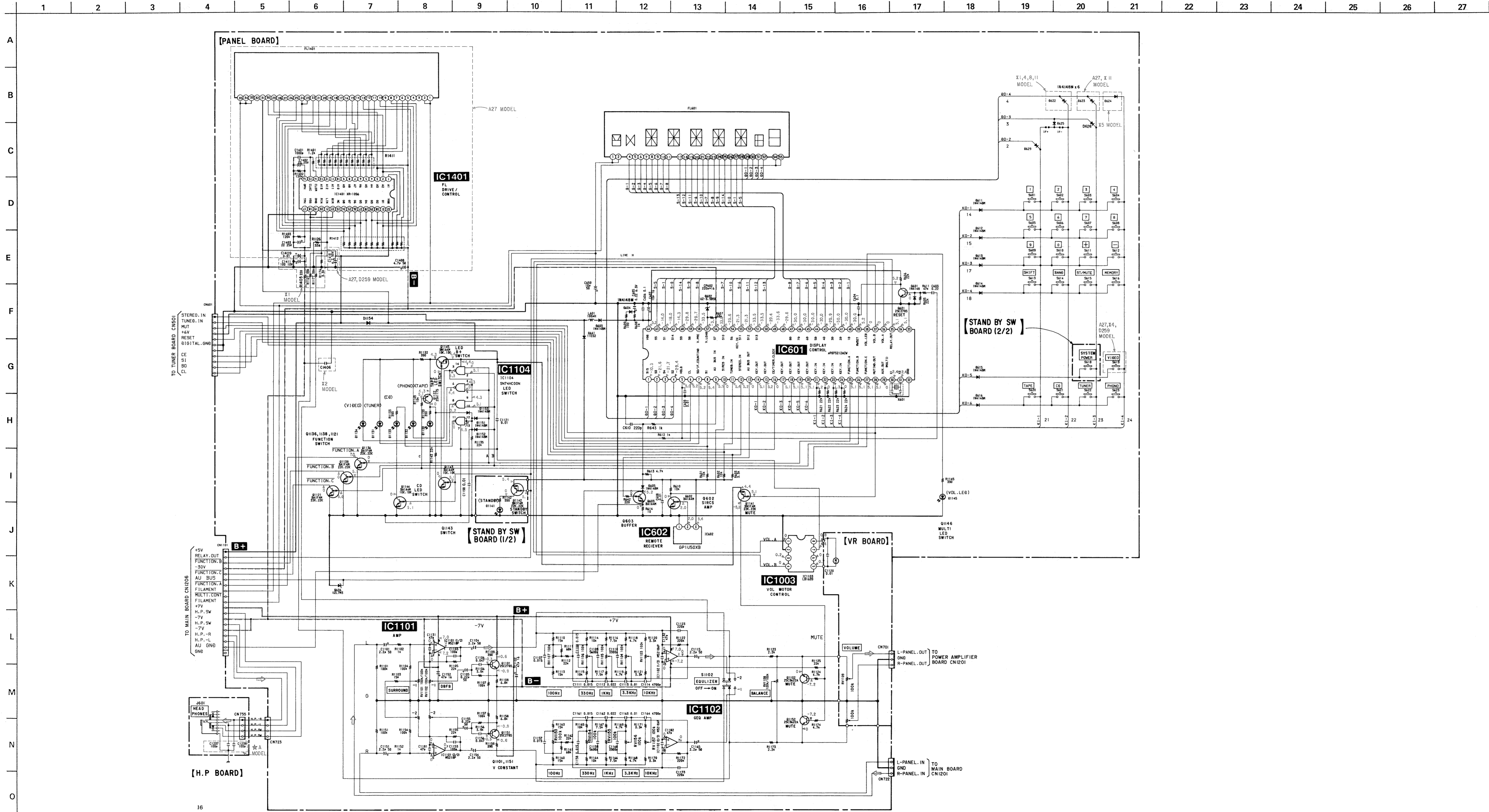

Note on Schematic Diagram :

- All capacitors are in μF unless otherwise noted. pF : μF 50WV or less are not indicated except for electrolytics and tantalums.
- All resistors are in Ω and $\frac{1}{2}$ W or less unless otherwise specified.
- \square : nonflammable resistor.
- --- : fusible resistor.

Note:
The components identified by mark Δ or dotted line with mark Δ are critical for safety. Replace only with part number specified.

Note:
Les composants identifiés par une marque Δ sont critiques pour la sécurité. Ne les remplacer que par une pièce portant le numéro spécifié.

□ : adjustment for repair.
○ : B + Line.
○ : B - Line.
no mark : FM
• Voltages are taken with a VOM (input Impedance 10 M Ω). Voltage variations may be noted due to normal production tolerances.
• Signal path.
◁ : FM
⇒ : AM

• Model name and destination shown by * 1 to * 11.
* 1 : A27 : Australian
* 2 : A27 : E, AU2
* 3 : D209 : UK
* 4 : D209 : Italian
* 5 : D209 : East European
* 6 : D209 : German
* 7 : D209 : AEP, AE2
* 8 : D259 : Italian
* 9 : D259 : AEP, AE2
* 10 : D259 : UK
* 11 : D259 : Canadian
★ A : * 4, 6, 8
★ B : * 3, 5, 7, 9, 10
★ C : 209 : AEP, * 3, 6, D259 : AEP, * 10

AU2 : AUS (with in PHONO MODEL)
AE2 : AEP (with in PHONO MODEL)

4-5. PRINTED WIRING BOARD — DISPLAY SECTION —

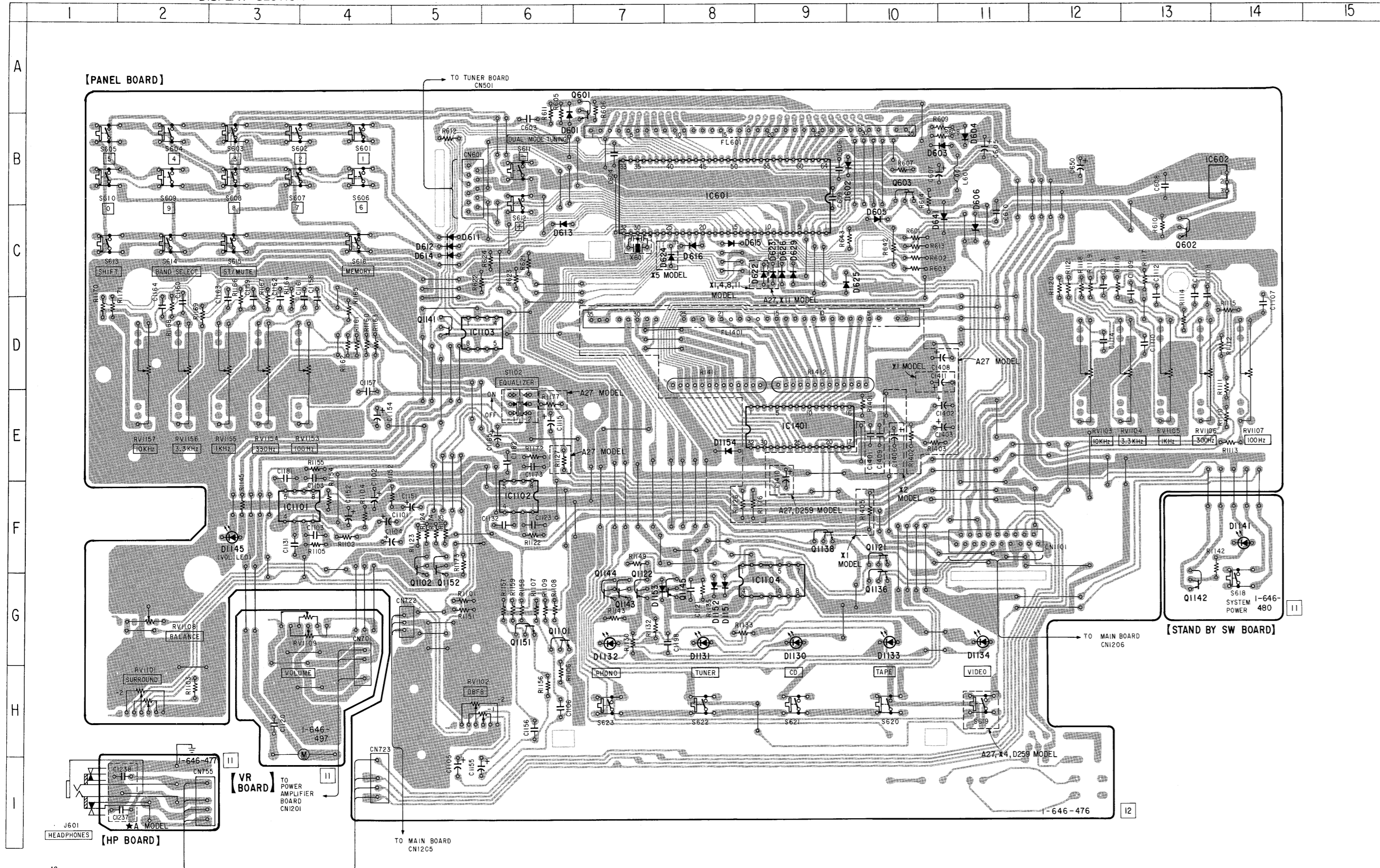

• Semiconductor Location

Ref. No.	Location	Ref. No.	Location
D601	B-6	D1153	G-7
D602	B-9	D1154	E-8
D603	B-10		
D604	B-11	IC601	B-8
D605	C-10	IC602	B-13
D606	B-11	IC1101	F-3
D611	C-5	IC1102	F-6
D612	C-5	IC1103	D-5
D613	C-6	IC1104	G-8
D614	C-5	IC1401	E-9
D615	C-8		
D616	C-8	Q601	A-6
D622	C-8	Q602	C-13
D623	C-9	Q603	B-10
D624	C-8	Q1101	G-6
D625	C-9	Q1102	G-5
D626	C-9	Q1121	F-10
D629	C-9	Q1122	F-7
D641	C-10	Q1136	G-10
D1130	G-9	Q1138	F-9
D1131	G-8	Q1141	D-5
D1132	G-7	Q1142	G-13
D1133	G-10	Q1143	G-7
D1134	G-11	Q1144	F-7
D1141	F-14	Q1145	G-8
D1145	F-3	Q1151	G-6
D1151	G-8	Q1152	G-5
D1152	G-8		

Note on Mounting Diagram :

- : Parts extracted from the component side.
 - : Pattern on the side which is seen.
- Model name and destination shown by * 1 to * 11.
 * 1 : A27 : Australian
 * 2 : A27 : E, AU2
 * 3 : D209 : UK
 * 4 : D209 : Italian
 * 5 : D209 : East European
 * 6 : D209 : German
 * 7 : D209 : AEP, AE2
 * 8 : D259 : Italian
 * 9 : D259 : AEP, AE2
 * 10 : D259 : UK
 * 11 : D259 : Canadian
 ★A : * 4, 6, 8
 ★B : * 3, 5, 7, 9, 10
 ★C : 209 : AEP, * 3, 6, D259 : AEP, * 10
- AU2 : AUS (with in PHONO MODEL)
 AE2 : AEP (with in PHONO MODEL)

4-6. CIRCUIT BOARDS LOCATION

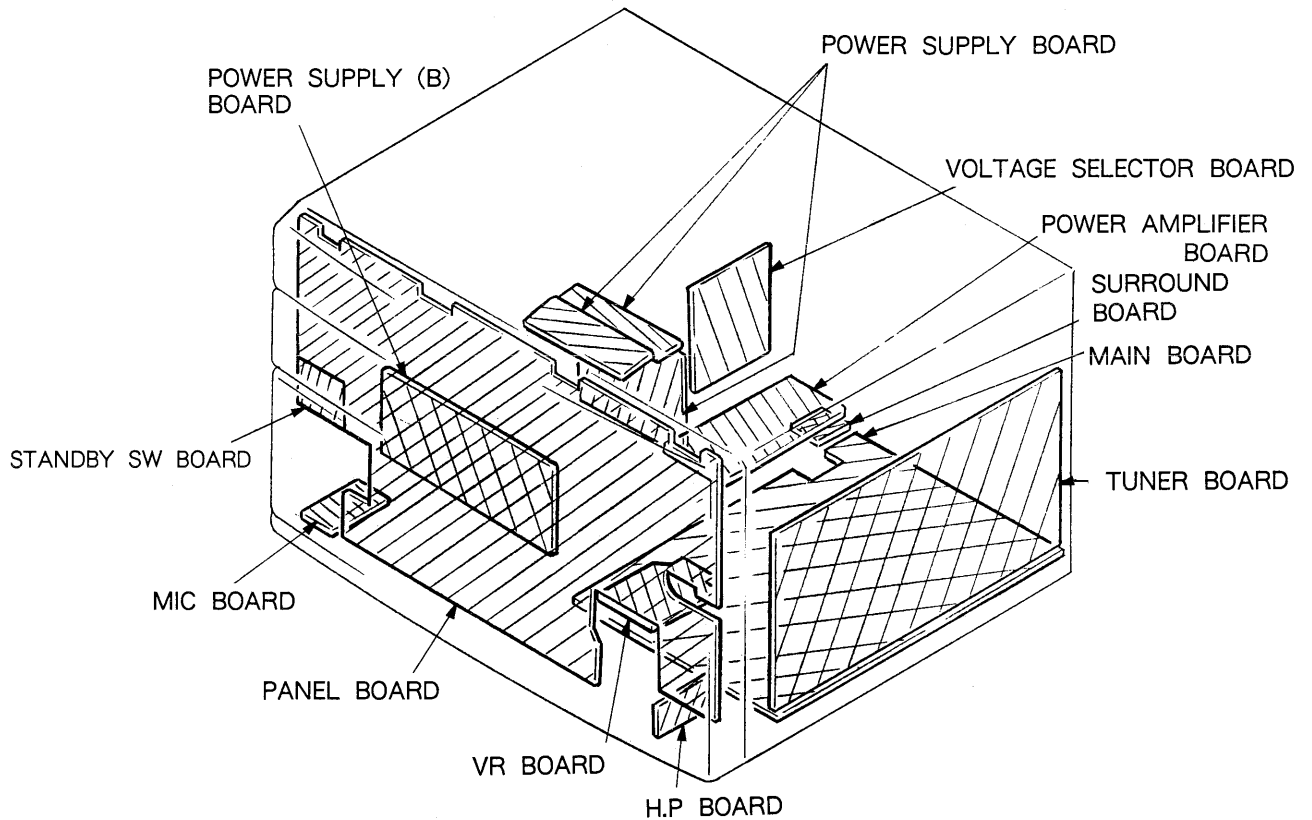

4-7. SEMICONDUCTOR LEAD LAYOUTS

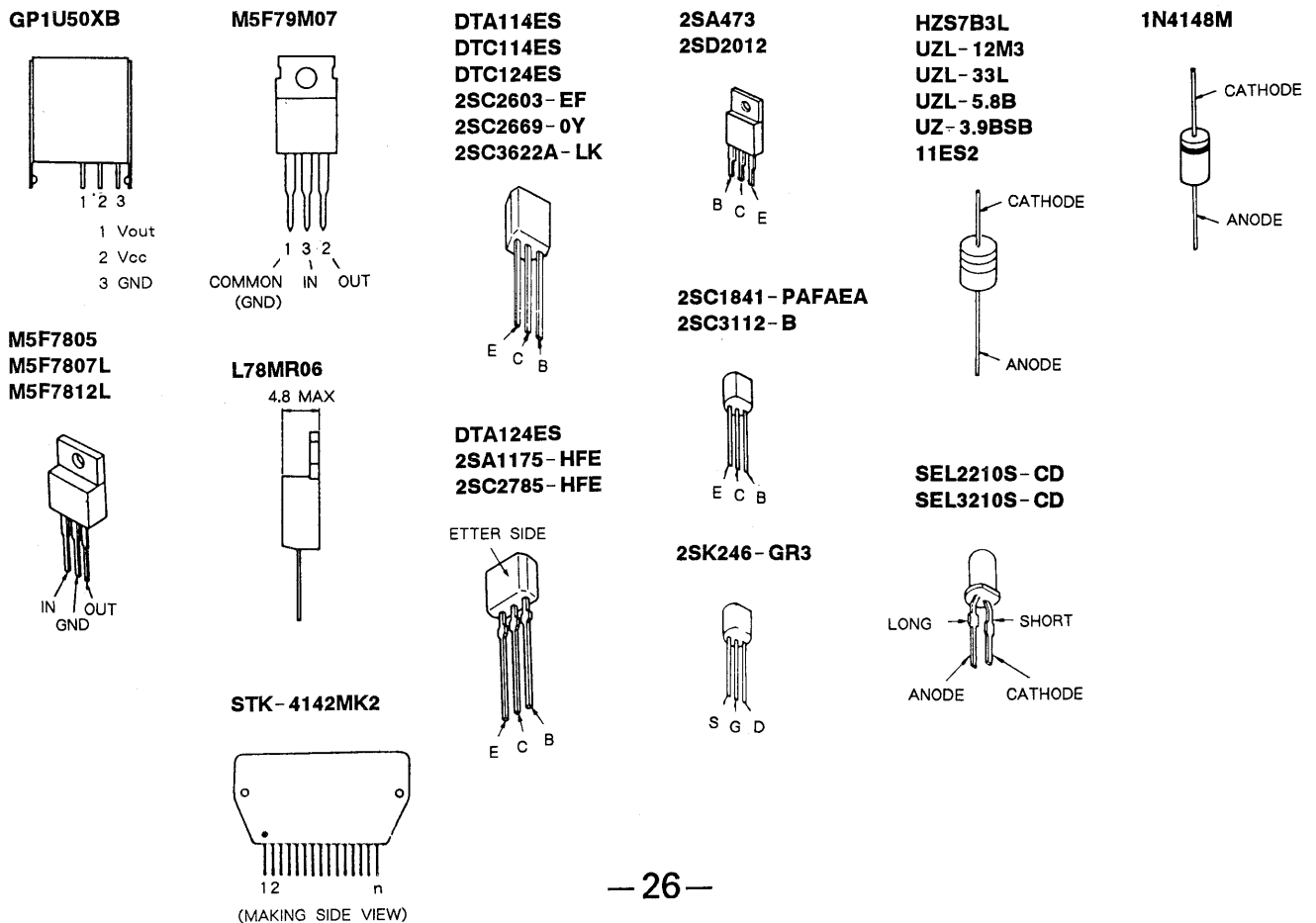

SECTION 5 EXPLODED VIEWS

NOTE:

- -XX, -X mean standardized parts, so they may have some differences from the original one.
- Color Indication of Appearance Parts
Example:
KNOB, BALANCE (WHITE)...(RED)
↑ ↑
Parts color Cabinet's color

- Items marked "*" are not stocked since they are seldom required for routine service. Some delay should be anticipated when ordering these items.
- The mechanical parts with no reference number in the exploded views are not supplied.
- Hardware (# mark) list is given in the last of this parts list.

- Model name and destination shown by *1 to *11.
- *1: A27: Australian
- *2: A27: E, AU2
- *3: D209: UK
- *4: D209: Italian
- *5: D209: East European
- *6: D209: German
- *7: D209: AEP, AE2
- *8: D259: Italian
- *9: D259: AEP, AE2
- *10: D259: UK
- *11: D259: Canadian
- ★A: *4, 6, 8
- ★B: *3, 5, 7, 9, 10
- ★C: 209: AEP, *3, 6, D259: AEP, *10
- AU2: AUS (with in PHONO MODEL)
- AE2: AEP (with in PHONO MODEL)

5-1. FRONT PANEL SECTION

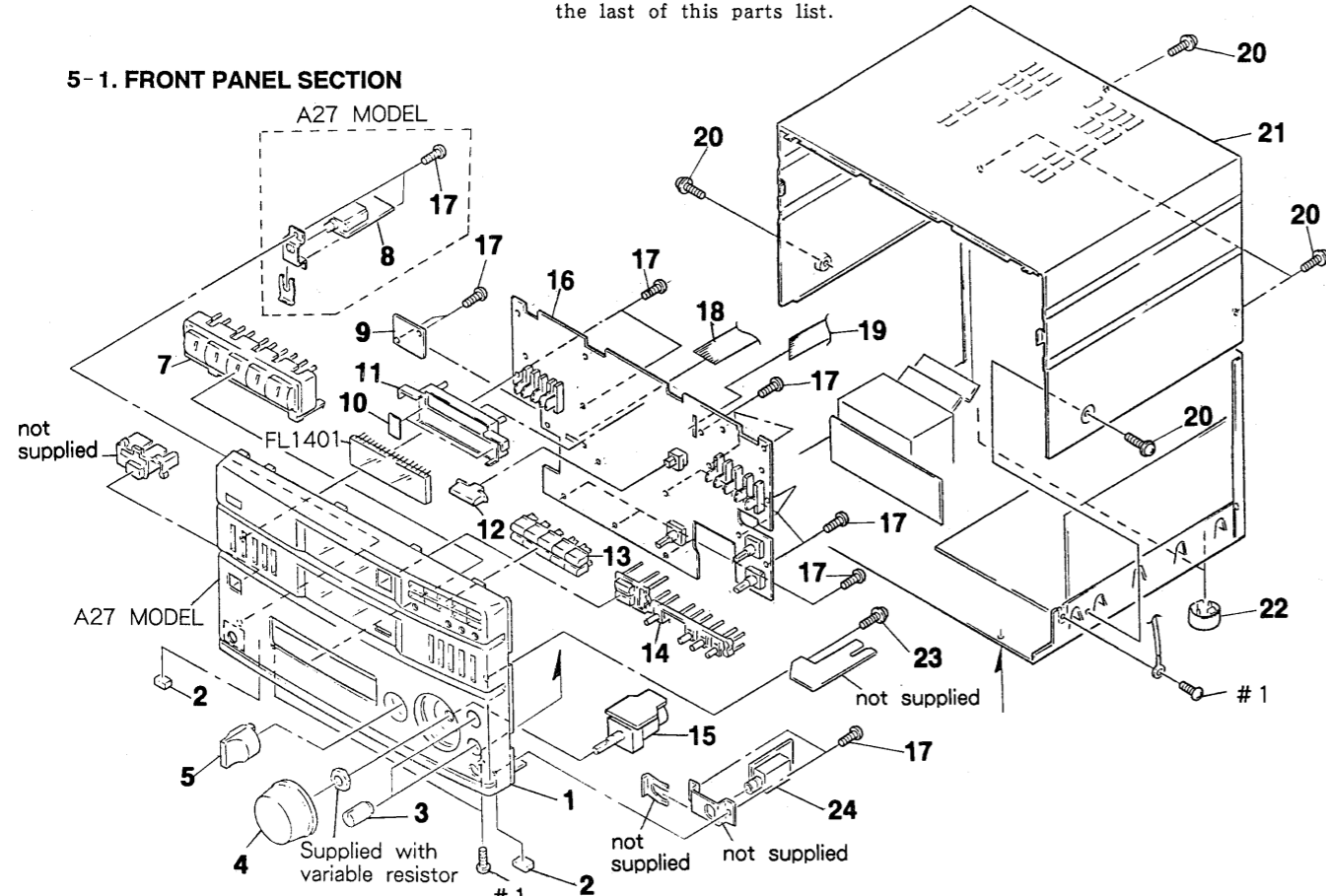

Ref. No.	Part No.	Description	Remarks	Ref. No.	Part No.	Description	Remarks
1	X-4943-180-1	PANEL ASSY, FRONT (#1)		* 16	A-4356-736-A	PANEL BOARD, COMPLETE (#2)	
1	X-4943-182-1	PANEL ASSY, FRONT (D209)		* 16	A-4356-623-A	PANEL BOARD, COMPLETE (#3)	
1	X-4943-242-2	PANEL ASSY, FRONT (#2)		* 16	A-4356-930-A	PANEL BOARD, COMPLETE (#4)	
1	X-4943-243-2	PANEL ASSY, FRONT (D259)		* 16	A-4360-822-A	PANEL BOARD, COMPLETE (#5)	
2	4-948-236-01	CUSHION (107)		* 16	A-4356-924-A	PANEL BOARD, COMPLETE (#6)	
3	4-955-744-01	KNOB (BA) (#1, D209)		* 16	A-4356-608-A	PANEL BOARD, COMPLETE (#7)	
3	4-955-744-21	KNOB (BA) (#2, D259)		* 16	A-4360-541-A	PANEL BOARD, COMPLETE (#8)	
4	4-955-635-01	KNOB (V) (#1, D209)		* 16	A-4360-531-A	PANEL BOARD, COMPLETE (#9)	
4	4-955-635-21	KNOB (V) (#2, D259)		* 16	A-4360-520-A	PANEL BOARD, COMPLETE (#10)	
5	4-955-636-01	KNOB (DB) (#1, D209)		* 16	A-4360-509-A	PANEL BOARD, COMPLETE (#11)	
5	4-955-636-22	KNOB (DB) (#2, D259)		17	4-951-620-01	SCREW (2. 6X8), +BVTP	
7	X-4943-179-1	BUTTON (FU) ASSY		18	1-590-578-11	WIRE, FLAT TYPE (19 CORE)	
* 8	1-646-479-11	MIC BOARD (A27)		19	1-590-576-11	WIRE, FLAT TYPE (11 CORE) (A27, D259)	
* 9	1-646-480-11	STAND-BY SW BOARD		19	1-590-576-21	WIRE, FLAT TYPE (11 CORE) (D209)	
* 10	4-949-935-31	CUSHION (FL)		20	3-704-366-01	SCREW (CASE) (M3X8)	
* 11	4-942-301-01	HOLDER, FL TUBE		* 21	4-955-759-11	CASE (#1, D209)	
12	4-955-755-01	BUTTON (EQ) (#1, D209)		* 21	4-955-759-51	CASE (#2, D259)	
12	4-955-755-11	BUTTON (EQ) (#2, D259)		22	4-933-601-01	FOOT (#2, D259)	
13	4-955-741-01	BUTTON (PR) (#1, D209)		22	X-4941-228-1	FOOT ASSY (#1, D209)	
13	4-955-741-21	BUTTON (PR) (#2, D259)		23	4-957-577-01	SCREW PTP WH (2. 6X8) (DIA. 10) (#1, D209)	
14	4-955-745-01	BUTTON (ST)		23	4-957-577-11	SCREW PTP WH (2. 6X8) (DIA. 10) (#2, D259)	
* 15	1-646-497-11	VR BOARD		* 24	1-646-477-11	H. P BOARD	
* 16	A-4356-640-A	PANEL BOARD, COMPLETE (#1)		FL1401	1-519-648-21	INDUCTOR TUBE, FLUORESCENT (A27)	

5-2. BACK PANEL SECTION

- ▲ : TUNER BOARD
- : VOLTAGE SELECTOR BOARD

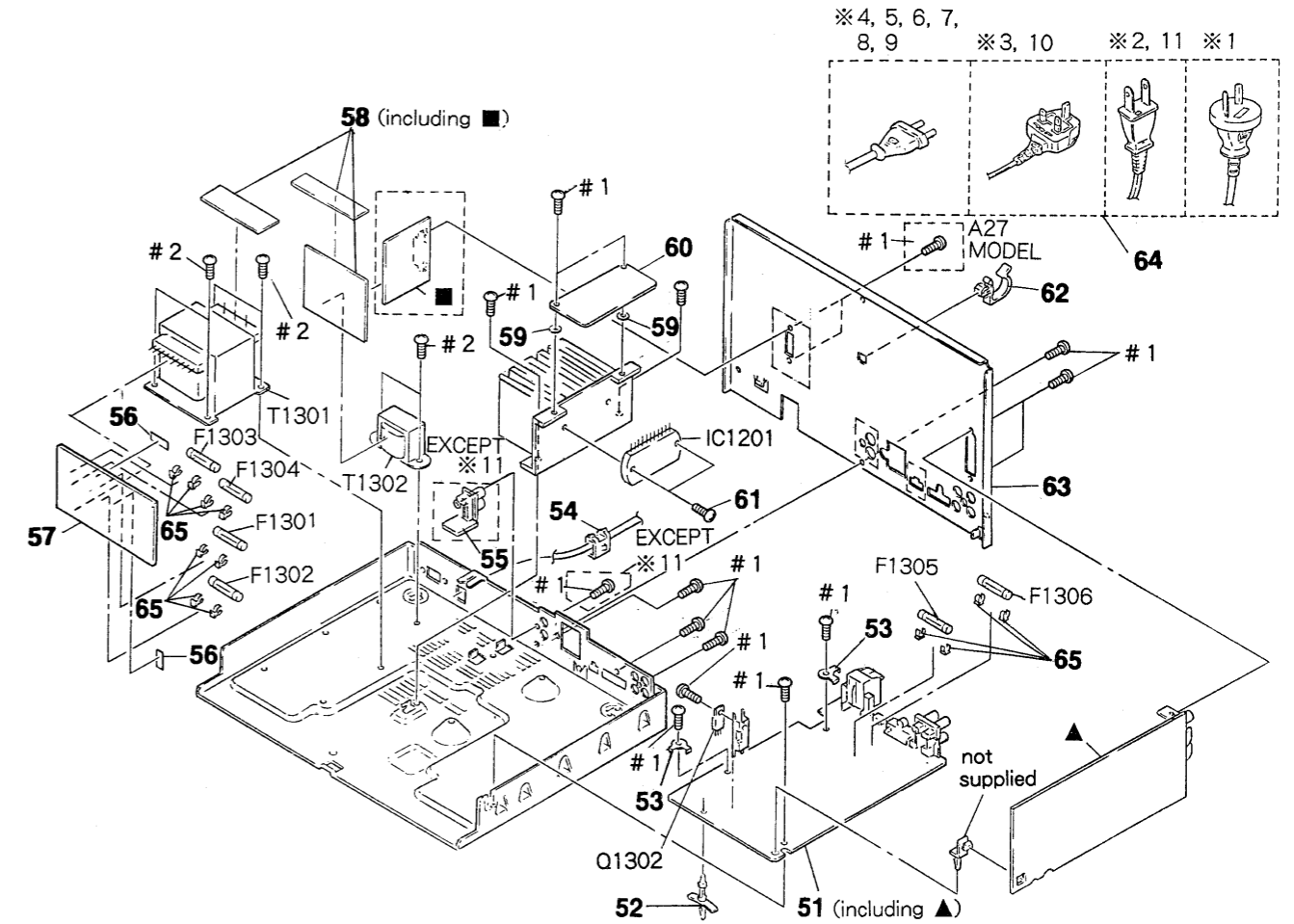

CAUTION

Be sure to use insulation sheet (▲4-959-364-01) when replacing power transformer because it is safely related part.

Ref. No.	Part No.	Description	Remarks	Ref. No.	Part No.	Description	Remarks
* 51	A-4356-650-A	MAIN BOARD, COMPLETE (*1)		* 63	4-955-778-91	PANEL, BACK (*6)	
* 51	A-4356-742-A	MAIN BOARD, COMPLETE (*2)		* 63	4-955-778-11	PANEL, BACK (D209:AEP)	
* 51	A-4356-630-A	MAIN BOARD, COMPLETE (*3)		* 63	4-955-778-81	PANEL, BACK (D209:AE2)	
* 51	A-4356-933-A	MAIN BOARD, COMPLETE (*4)		* 63	4-955-824-31	PANEL, BACK (*8)	
* 51	A-4360-821-A	MAIN BOARD, COMPLETE (*5)		* 63	4-955-824-11	PANEL, BACK (D259:AEP)	
* 51	A-4356-926-A	MAIN BOARD, COMPLETE (*6)		* 63	4-955-824-81	PANEL, BACK (D259:AE2)	
* 51	A-4356-618-A	MAIN BOARD, COMPLETE (D209:AEP)		* 63	4-955-824-21	PANEL, BACK (*10)	
* 51	A-4356-928-A	MAIN BOARD, COMPLETE (D209:AE2)		* 63	4-955-824-51	PANEL, BACK (*11)	
* 51	A-4360-543-A	MAIN BOARD, COMPLETE (*8)		△64	1-696-848-21	CORD, POWER (*1)	
* 51	A-4360-534-A	MAIN BOARD, COMPLETE (D259:AEP)		△64	1-690-608-11	CORD, POWER (A27:AU2)	
* 51	A-4360-538-A	MAIN BOARD, COMPLETE (D259:AE2)		△64	1-575-653-11	CORD, POWER (A27:E)	
* 51	A-4360-523-A	MAIN BOARD, COMPLETE (*10)		△64	1-696-570-21	CORD, POWER (*3, 10)	
* 51	A-4360-511-A	MAIN BOARD, COMPLETE (*11)		△64	1-575-651-11	CORD, POWER (*4, 5, 6, 7, 8, 9)	
* 52	4-954-051-51	HOLDER, PC BOARD		△64	1-690-609-21	CORD, POWER (*11)	
* 53	4-942-204-01	PLATE, GROUND		65	1-533-217-31	HOLDER, FUSE (*1, D209)	
* 54	3-703-244-00	BUSHING (2104), CORD (EXCEOT A27:E)		* 65	1-533-213-11	HOLDER, FUSE (*2, D259)	
* 54	3-703-571-11	BUSHING (S)(4516), CORD (A27:E)		△F1301	1-532-350-00	FUSE 4A (A27, D209, *9, 10)	
* 55	1-646-484-11	SURROUND BOARD (EXCEPT *11)		△F1301	1-576-108-11	FUSE 4A (*8, 11)	
* 56	3-701-946-26	LABEL (4A125V), FUSE (*11)		△F1302	1-532-350-00	FUSE 4A (A27, D209, *9, 10)	
* 57	1-646-478-11	POWER SUPPLY (B) BOARD		△F1302	1-576-108-11	FUSE 4A (*8, 11)	
* 58	1-646-474-11	POWER SUPPLY BOARD		△F1303	1-532-203-00	FUSE 2A (D209, *9, 10)	
59	3-330-034-01	WASHER (*2, D259)		△F1303	1-532-286-00	FUSE 2.5A (A27, D209, *9, 10)	
59	3-564-542-00	WASHER, FIBER (D209)		△F1303	1-576-104-11	FUSE 2A (*8)	
* 60	A-4356-649-A	POWER AMPLIFIER BOARD, COMPLETE (*1)		△F1304	1-532-203-00	FUSE 2A (D209, *9, 10)	
* 60	A-4356-749-A	POWER AMPLIFIER BOARD, COMPLETE (*2)		△F1304	1-532-286-00	FUSE 2.5A (A27, D209, *9, 10)	
* 60	A-4356-628-A	POWER AMPLIFIER BOARD, COMPLETE (*3)		△F1304	1-576-104-11	FUSE 2A (*8)	
* 60	A-4356-935-A	POWER AMPLIFIER BOARD, COMPLETE (*4, 6)		△F1305	1-532-286-00	FUSE 2.5A (A27, D209, *9, 10)	
* 60	A-4356-616-A	POWER AMPLIFIER BOARD, COMPLETE (*5, 7)		△F1305	1-576-105-11	FUSE 2.5A (*8, 11)	
* 60	A-4360-546-A	POWER AMPLIFIER BOARD, COMPLETE (*8)		△F1306	1-532-286-00	FUSE 2.5A (A27, D209, *9, 10)	
* 60	A-4360-537-A	POWER AMPLIFIER BOARD, COMPLETE (*9)		△F1306	1-576-105-11	FUSE 2.5A (*8, 11)	
* 60	A-4360-527-A	POWER AMPLIFIER BOARD, COMPLETE (*10)		IC1201	8-749-900-24	IC STK-4162MK2 (A27, *11)	
* 60	A-4360-516-A	POWER AMPLIFIER BOARD, COMPLETE (*11)		IC1201	8-749-900-96	IC STK-4162MK2 (D209, *8, 9, 10)	
61	4-928-635-11	SCREW, +BV (2.6X16) TAPPING		Q1302	8-729-209-15	TRANSISTOR 2SD2012	
* 62	4-949-235-01	HOOK (*2, 4, 5, 6, 7, 9, 11)		△T1301	1-423-438-11	TRANSFORMER, POWER (*1)	
* 63	4-955-781-11	PANEL, BACK (*1)		△T1301	1-423-438-21	TRANSFORMER, POWER (*2)	
* 63	4-955-824-91	PANEL, BACK (A27:E)		△T1301	1-423-437-11	TRANSFORMER, POWER (D209)	
* 63	4-955-824-61	PANEL, BACK (A27:AU2)		△T1301	1-423-437-21	TRANSFORMER, POWER (*8, 9, 10)	
* 63	4-955-778-21	PANEL, BACK (*3)		△T1301	1-423-431-11	TRANSFORMER, POWER (*11)	
* 63	4-955-778-31	PANEL, BACK (*4)		△T1302	1-449-723-31	TRANSFORMER, POWER (EXCEPT *11)	
* 63	4-955-778-41	PANEL, BACK (*5)		△T1302	1-450-786-11	TRANSFORMER, POWER (*11)	

Note:
The components identified by mark \triangle or dotted line with mark \triangle are critical for safety.
Replace only with part number specified.

Note:
Les composants identifiés par une marque \triangle sont critiques pour la sécurité.
Ne les remplacer que par une pièce portant le numéro spécifié.

MAIN SURROUND

**SECTION 6
ELECTRICAL PARTS LIST**

- Model name and destination shown by * 1 to * 11.
 - * 1 : A27 : Australian
 - * 2 : A27 : E, AU2
 - * 3 : D209 : UK
 - * 4 : D209 : Italian
 - * 5 : D209 : East European
 - * 6 : D209 : German
 - * 7 : D209 : AEP, AE2
 - * 8 : D259 : Italian
 - * 9 : D259 : AEP, AE2
 - * 10 : D259 : UK
 - * 11 : D259 : Canadian
 - ★ A : * 4, 6, 8
 - ★ B : * 3, 5, 7, 9, 10
 - ★ C : 209 : AEP, * 3, 6, D259 : AEP, * 10
- AU2 : AUS (with in PHONO MODEL)
AE2 : AEP (with in PHONO MODEL)

NOTE:

- Due to standardization, replacements in the parts list may be different from the parts specified in the diagrams or the components used on the set.
- -XX, -X mean standardized parts, so they may have some difference from the original one.
- RESISTORS
All resistors are in ohms.
METAL : metal-film resistor
METAL OXIDE : Metal Oxide-film resistor
F : nonflammable
- Items marked "*" are not stocked since they are seldom required for routine service. Some delay should be anticipated when ordering these items.
- SEMICONDUCTORS
In each case, u : μ , for example :
uA... : μ A..., uPA..., μ PA...,
uPB..., μ PB..., uPC..., μ PC...,
uPD..., μ PD...
- CAPACITORS :
uF : μ F
- COILS
uH : μ H

Ref. No.	Part No.	Description	Remarks	Ref. No.	Part No.	Description	Remarks
*	A-4356-650-A	MAIN BOARD, COMPLETE (*1) *****				< CAPACITOR >	
*	A-4356-742-A	MAIN BOARD, COMPLETE (*2) *****		C301	1-161-379-00	CERAMIC 0.01uF	20% 25V (★:A)
*	A-4356-630-A	MAIN BOARD, COMPLETE (*3) *****		C302	1-124-477-11	ELECT 47uF	20% 25V
*	A-4356-933-A	MAIN BOARD, COMPLETE (*4) *****		C303	1-161-379-00	CERAMIC 0.01uF	20% 25V
*	A-4360-821-A	MAIN BOARD, COMPLETE (*5) *****		C305	1-161-379-00	CERAMIC 0.01uF	20% 25V (★:A)
*	A-4356-926-A	MAIN BOARD, COMPLETE (*6) *****		C306	1-161-379-00	CERAMIC 0.01uF	20% 25V (★:A)
*	A-4356-618-A	MAIN BOARD, COMPLETE (D209:AEP) *****		C307	1-161-379-00	CERAMIC 0.01uF	20% 25V (EXCEPT *1)
*	A-4356-928-A	MAIN BOARD, COMPLETE (D209:AE2) *****		C308	1-161-379-00	CERAMIC 0.01uF	20% 25V (EXCEPT *1)
*	A-4360-543-A	MAIN BOARD, COMPLETE (*8) *****		C309	1-161-379-00	CERAMIC 0.01uF	20% 25V
*	A-4360-534-A	MAIN BOARD, COMPLETE (D259:AEP) *****		C310	1-124-477-11	ELECT 47uF	20% 25V
*	A-4360-538-A	MAIN BOARD, COMPLETE (D259:AE2) *****		C311	1-161-379-00	CERAMIC 0.01uF	20% 25V
*	A-4360-523-A	MAIN BOARD, COMPLETE (*10) *****		C312	1-101-006-00	CERAMIC 0.047uF	50V
*	A-4360-511-A	MAIN BOARD, COMPLETE (*11) *****		C313	1-123-382-00	ELECT 3.3uF	20% 100V
*	1-646-484-11	SURROUND BOARD (EXCEPT *11) *****		C314	1-161-379-00	CERAMIC 0.01uF	20% 25V
*	1-533-213-11	HOLDER, FUSE (*2, D259)		C315	1-161-329-00	CERAMIC 0.0068uF	30% 16V
*	1-533-213-31	HOLDER, FUSE (*2, D259)		C316	1-162-282-31	CERAMIC 100PF	10% 50V
*	1-533-217-31	HOLDER, FUSE (*1, D209)		C317	1-162-292-31	CERAMIC 680PF	10% 50V (*4, 6)
*	1-533-293-11	FUSE HOLDER (*2, D259)		C317	1-162-289-31	CERAMIC 390PF	10% 50V (*8)
*	4-942-204-01	PLATE, GROUND		C318	1-124-903-11	ELECT 1uF	20% 50V
	7-685-646-79	SCREW +BVTP 3X8 TYPE2 N-S (*6)		C320	1-124-903-11	ELECT 1uF	20% 50V
				C321	1-124-902-00	ELECT 0.47uF	20% 50V
				C322	1-124-463-00	ELECT 0.1uF	20% 50V
				C323	1-161-329-00	CERAMIC 0.0068uF	20% 16V (EXCEPT *11)
				C323	1-161-379-00	CERAMIC 0.01uF	20% 25V (*11)
				C324	1-161-329-00	CERAMIC 0.0068uF	20% 16V (EXCEPT *11)
				C324	1-161-379-00	CERAMIC 0.01uF	20% 25V (*11)
				C325	1-124-477-11	ELECT 47uF	20% 25V
				C326	1-124-907-11	ELECT 10uF	20% 50V
				C327	1-161-379-00	CERAMIC 0.01uF	20% 25V
				C328	1-124-463-00	ELECT 0.1uF	20% 50V

<p>Note: The components identified by mark Δ or dotted line with mark Δ are critical for safety. Replace only with part number specified.</p>	<p>Note: Les composants identifiés par une marque Δ sont critiques pour la sécurité. Ne les remplacer que par une pièce portant le numéro spécifié.</p>
--	--

When indicating parts by reference number, please include the board name.

Ref. No.	Part No.	Description	Remarks
C329	1-124-927-11	ELECT	4.7uF 20% 100V
C330	1-161-379-00	CERAMIC	0.01uF 20% 25V
C331	1-126-176-11	ELECT	220uF 20% 10V
C332	1-161-379-00	CERAMIC	0.01uF 20% 25V
C335	1-161-379-00	CERAMIC	0.01uF 20% 25V
C336	1-161-379-00	CERAMIC	0.01uF 20% 25V
C339	1-162-210-31	CERAMIC	30PF 5% 50V (★:B)
C341	1-123-382-00	ELECT	3.3uF 20% 100V
C342	1-123-382-00	ELECT	3.3uF 20% 100V
C343	1-123-382-00	ELECT	3.3uF 20% 100V
C344	1-123-382-00	ELECT	3.3uF 20% 100V
C345	1-161-375-00	CERAMIC	0.0022uF 20% 50V
C346	1-161-375-00	CERAMIC	0.0022uF 20% 50V
C351	1-161-494-00	CERAMIC	0.022uF 25V (★:B)
C352	1-102-120-00	CERAMIC	0.0018uF 10% 50V (★:B)
C353	1-161-374-11	CERAMIC	0.0015uF 20% 50V (★:B)
C354	1-161-494-00	CERAMIC	0.022uF 25V (★:B)
C361	1-164-098-11	CERAMIC	0.047uF 12V
C361	1-161-379-00	CERAMIC	0.01uF 20% 25V (*4, 6)
C362	1-161-494-00	CERAMIC	0.022uF 25V
C363	1-164-159-11	CERAMIC	0.1uF 50V (★:B)
C364	1-161-494-00	CERAMIC	0.022uF 25V (★:B)
C371	1-162-198-31	CERAMIC	8.2PF 10% 50V (EXCEPT ★:B)
C371	1-162-196-31	CERAMIC	5.6PF 10% 50V (★:B)
C373	1-162-288-31	CERAMIC	330PF 10% 50V (*7, *8)
C501	1-102-961-00	CERAMIC	27PF 5% 50V
C502	1-102-961-00	CERAMIC	27PF 5% 50V
C503	1-124-477-11	ELECT	47uF 20% 25V
C504	1-161-379-00	CERAMIC	0.01uF 20% 25V
C505	1-161-379-00	CERAMIC	0.01uF 20% 25V
C506	1-161-379-00	CERAMIC	0.01uF 20% 25V
C507	1-161-379-00	CERAMIC	0.01uF 20% 25V
C521	1-124-925-11	ELECT	2.2uF 20% 100V
C522	1-124-463-00	ELECT	0.1uF 20% 50V
C523	1-161-379-00	CERAMIC	0.01uF 20% 25V
C524	1-161-379-00	CERAMIC	0.01uF 20% 25V
C525	1-124-477-11	ELECT	47uF 20% 25V (EXCEPT *5)
C525	1-126-101-11	ELECT	100uF 20% 16V (*5)
C531	1-136-173-00	FILM	0.47uF 5% 50V (★:B)
C532	1-161-494-00	CERAMIC	0.022uF 25V (★:B)
C533	1-124-463-00	ELECT	0.1uF 20% 50V (★:B)
C1001	1-124-925-11	ELECT	2.2uF 20% 100V
C1002	1-162-282-31	CERAMIC	100PF 10% 50V
C1003	1-162-282-31	CERAMIC	100PF 10% 50V
C1004	1-124-477-11	ELECT	47uF 20% 25V
C1005	1-161-377-00	CERAMIC	0.0047uF 20% 16V
C1006	1-161-374-11	CERAMIC	0.0015uF 20% 50V
C1007	1-124-464-11	ELECT	0.22uF 20% 50V
C1008	1-124-477-11	ELECT	47uF 20% 25V
C1010	1-124-477-11	ELECT	47uF 20% 25V
C1012	1-124-925-11	ELECT	2.2uF 20% 100V

Ref. No.	Part No.	Description	Remarks
C1013	1-162-290-31	CERAMIC	470PF 10% 50V
C1014	1-161-494-00	CERAMIC	0.022uF 25V
C1025	1-162-286-31	CERAMIC	220PF 10% 50V
C1026	1-162-286-31	CERAMIC	220PF 10% 50V
C1051	1-124-925-11	ELECT	2.2uF 20% 100V
C1052	1-162-282-31	CERAMIC	100PF 10% 50V
C1053	1-162-282-31	CERAMIC	100PF 10% 50V
C1054	1-124-477-11	ELECT	47uF 20% 25V
C1055	1-161-377-00	CERAMIC	0.0047uF 20% 16V
C1056	1-161-374-11	CERAMIC	0.0015uF 20% 50V
C1057	1-124-464-11	ELECT	0.22uF 20% 50V
C1058	1-124-477-11	ELECT	47uF 20% 25V
C1060	1-124-477-11	ELECT	47uF 20% 25V
C1062	1-124-925-11	ELECT	2.2uF 20% 100V
C1063	1-162-290-31	CERAMIC	470PF 10% 50V
C1064	1-161-494-00	CERAMIC	0.022uF 25V
C1075	1-162-286-31	CERAMIC	220PF 10% 50V
C1076	1-162-286-31	CERAMIC	220PF 10% 50V
C1212	1-124-916-11	ELECT	22uF 20% 63V
C1213	1-124-916-11	ELECT	22uF 20% 63V
C1221	1-126-101-11	ELECT	100uF 20% 16V
C1222	1-126-176-11	ELECT	220uF 20% 10V
C1223	1-126-176-11	ELECT	220uF 20% 10V
C1245	1-101-006-00	CERAMIC	0.047uF 50V (★:A)
C1246	1-101-006-00	CERAMIC	0.047uF 50V (★:A)
C1247	1-101-006-00	CERAMIC	0.047uF 50V (★:A)
C1248	1-101-006-00	CERAMIC	0.047uF 50V (★:A)
C1249	1-161-494-00	CERAMIC	0.022uF 25V (★:A)
C1250	1-161-494-00	CERAMIC	0.022uF 25V (★:A)
C1262	1-124-916-11	ELECT	22uF 20% 63V
C1263	1-124-916-11	ELECT	22uF 20% 63V
C1294	1-161-494-00	CERAMIC	0.022uF 25V (★:A)
C1302	1-102-394-11	CERAMIC	0.01uF 250V
C1304	1-126-224-11	ELECT	4700uF 20% 42V
C1305	1-126-224-11	ELECT	4700uF 20% 42V
C1306	1-124-477-11	ELECT	47uF 20% 25V
C1307	1-124-893-11	ELECT	2200uF 20% 10V
C1308	1-126-101-11	ELECT	100uF 20% 16V
C1309	1-124-556-11	ELECT	2200uF 20% 16V (A27, *11)
C1309	1-126-101-11	ELECT	100uF 20% 16V (D209, *8, 9, 10)
C1312	1-124-564-11	ELECT	4700uF 20% 25V (A27, *11)
C1312	1-124-563-11	ELECT	2200uF 20% 25V (D209, *8, 9, 10)
C1313	1-124-564-11	ELECT	4700uF 20% 25V (A27, *11)
C1313	1-124-563-11	ELECT	2200uF 20% 25V (D209, *8, 9, 10)
C1319	1-124-463-00	ELECT	0.1uF 20% 50V
C1320	1-124-907-11	ELECT	10uF 20% 50V
C1321	1-161-379-00	CERAMIC	0.01uF 20% 25V

MAIN	SURROUND
------	----------

Ref. No.	Part No.	Description	Remarks
C1322	1-161-379-00	CERAMIC 0.01uF	20% 25V
C1324	1-124-907-11	ELECT 10uF	20% 50V
C1326	1-124-907-11	ELECT 10uF	20% 50V
C1328	1-124-907-11	ELECT 10uF	20% 50V
C1330	1-126-101-11	ELECT 100uF	20% 16V
C1331	1-102-394-11	CERAMIC 0.01uF	250V
C1335	1-124-907-11	ELECT 10uF	20% 50V (★:C)
C1336	1-126-101-11	ELECT 100uF	20% 16V (★:C)
C1341	1-124-907-11	ELECT 10uF	20% 50V
C1346	1-124-925-11	ELECT 2.2uF	20% 100V
C1351	1-124-122-11	ELECT 100uF	20% 50V
C1352	1-126-105-11	ELECT 1000uF	20% 35V
C1353	1-136-165-00	FILM 0.1uF	5% 50V
C1354	1-136-165-00	FILM 0.1uF	5% 50V
C1360	1-161-494-00	CERAMIC 0.022uF	25V
			(*2, D259)
C1361	1-124-122-11	ELECT 100uF	20% 50V

< FILTER >

CF301	1-577-070-81	FILTER, CERAMIC (EXCEPT ★:A)
CF301	1-567-389-11	FILTER, CERAMIC (★:A)
CF303	1-577-070-81	FILTER, CERAMIC (EXCEPT ★:A)
CF303	1-567-389-11	FILTER, CERAMIC (★:A)
CF304	1-577-075-11	OSCILLATOR, CERAMIC

< CONNECTOR >

* CN212	1-564-506-11	PLUG, CONNECTOR 3P
CN302	1-695-089-11	PIN, CONNECTOR (PC BOARD) 11P
* CN501	1-568-830-11	SOCKET, CONNECTOR 11P
* CN1001	1-580-912-21	JACK, PIN 4P (IN) (*2, D259)
* CN1001	1-580-912-11	JACK, PIN 4P (IN) (*1, D209)
* CN1006	1-568-955-11	PIN, CONNECTOR 6P (A27)
CN1201	1-537-494-11	TERMINAL BOARD (SPEAKER) (EXCEPT *4, 8)
CN1201	1-537-481-11	TERMINAL BOARD (SPEAKER) (*4, 8)
* CN1203	1-564-508-11	PLUG, CONNECTOR 5P
CN1205	1-506-468-11	PIN, CONNECTOR 3P
CN1206	1-568-802-11	SOCKET, CONNECTOR 19P
* CN1241	1-565-291-11	SOCKET, CONNECTOR 13P (SYSTEM CONTROL)
CN1243	1-695-094-11	SOCKET, CONNECTOR 11P
CN1244	1-506-469-11	PIN, CONNECTOR 4P (A27, *9, 10, 11)
* CN1301	1-566-210-11	PIN, CONNECTOR 3P (POWER SOURCE) (★:C)

CN1302 1-506-469-11 PIN, CONNECTOR 4P

< DIODE >

D351	8-719-987-63	DIODE 1N4148M (★:B)
D1202	8-719-987-63	DIODE 1N4148M
D1203	8-719-987-63	DIODE 1N4148M
D1204	8-719-987-63	DIODE 1N4148M
D1205	8-719-933-48	DIODE HZS7B3L
D1302	8-719-312-09	DIODE RBA-402
D1303	8-719-200-82	DIODE 11ES2

Ref. No.	Part No.	Description	Remarks
D1304	8-719-200-82	DIODE 11ES2	
D1305	8-719-200-82	DIODE 11ES2	
D1306	8-719-200-82	DIODE 11ES2	
D1316	8-719-200-82	DIODE 11ES2	
D1317	8-719-200-82	DIODE 11ES2	
D1318	8-719-200-82	DIODE 11ES2	
D1319	8-719-200-82	DIODE 11ES2	
D1321	8-719-987-63	DIODE 1N4148M	
D1323	8-719-987-63	DIODE 1N4148M	
D1324	8-719-987-63	DIODE 1N4148M	
D1341	8-719-001-76	DIODE UZL-12M3	
D1347	8-719-987-63	DIODE 1N4148M	
D1368	8-719-200-82	DIODE 11ES2	

D1369 8-719-200-82 DIODE 11ES2

< FRONTEND >

FE301	1-465-006-11	FRONT END (FM) (2 GANG) (*2, 3)
FE301	1-693-090-21	FRONT END (FM) (2 GANG) (*1, 7, 9, 10, 11)
FE301	1-463-857-21	FRONT END (★:A)
FE301	1-465-396-11	FRONT END (FM 3GANG) (*5)
FE351	1-236-463-11	ENCAPSULATED COMPONENT (★:B)
FE352	1-239-260-11	ENCAPSULATED COMPONENT (EXCEPT ★:B)
FE352	1-239-261-12	ENCAPSULATED COMPONENT (★:B)

< IC >

IC301	8-759-821-45	IC LA1851N
IC501	8-759-820-91	IC LC7218
IC1001	8-759-634-51	IC M5218AP
IC1002	8-759-000-48	IC MC14052BCP
IC1003	8-759-634-51	IC M5218AP
IC1202	8-759-111-68	IC uPC1237HA
IC1302	8-759-231-53	IC M5F7805
IC1303	8-759-071-48	IC M5F7807L
IC1304	8-759-604-95	IC M5F79M07
IC1305	8-759-820-13	IC L78MR06
IC1306	8-759-231-58	IC M5F7812L (★:C)

< JACK >

* J1202	1-569-130-11	JACK, PIN 2P (SURROUND SPEAKER)
		(EXCEPT *11)

< IFT >

IFT301	1-404-713-11	TRANSFORMER, IF
--------	--------------	-----------------

< COIL >

L301	1-410-686-11	INDUCTOR 1mH (A27, *11)
L301	1-407-500-00	INDUCTOR 4.7mH (D209, *8, 9, 10)
L351	1-410-525-11	INDUCTOR 220uH (★:B)
L1301	1-408-117-00	INDUCTOR 10uH (*6)
L1302	1-408-117-00	INDUCTOR 10uH (*6)

Ref. No.	Part No.	Description	Remarks
< FILTER >			
LPF301	1-235-164-00	FILTER, LOW PASS	
LPF302	1-235-164-00	FILTER, LOW PASS	
< TRANSISTOR >			
Q301	8-729-230-99	TRANSISTOR 2SC2669-OY (★:A)	
Q302	8-729-230-99	TRANSISTOR 2SC2669-OY (★:A)	
Q303	8-729-230-99	TRANSISTOR 2SC2669-OY (EXCEPT *1)	
Q304	8-729-230-99	TRANSISTOR 2SC2669-OY	
Q305	8-729-900-80	TRANSISTOR DTC114ES	
Q306	8-729-900-61	TRANSISTOR DTA114ES	
Q307	8-729-900-80	TRANSISTOR DTC114ES	
Q308	8-729-620-05	TRANSISTOR 2SC2603-EF (*2, D259)	
Q308	8-729-119-78	TRANSISTOR 2SC2785-HFE (*1, D209)	
Q309	8-729-620-05	TRANSISTOR 2SC2603-EF (*2, D259)	
Q309	8-729-119-78	TRANSISTOR 2SC2785-HFE (*1, D209)	
Q351	8-729-900-80	TRANSISTOR DTC114ES (★:B)	
Q352	8-729-119-78	TRANSISTOR 2SC2785-HFE (*3, 5, 7)	
Q352	8-729-620-05	TRANSISTOR 2SC2603-EF (*9, 10)	
Q353	8-729-119-76	TRANSISTOR 2SA1175-HFE (★:B)	
Q354	8-729-900-80	TRANSISTOR DTC114ES (★:B)	
Q355	8-729-900-80	TRANSISTOR DTC114ES (★:B)	
Q356	8-729-900-80	TRANSISTOR DTC114ES (★:B)	
Q501	8-729-900-80	TRANSISTOR DTC114ES	
Q502	8-729-900-61	TRANSISTOR DTA114ES	
Q521	8-729-202-67	TRANSISTOR 2SK246-GR3	
Q522	8-729-201-84	TRANSISTOR 2SC3112-B (A27, *11)	
Q522	8-729-141-26	TRANSISTOR 2SC3622A-LK (D209, *8, 9, 10)	
Q531	8-729-202-67	TRANSISTOR 2SK246-GR3 (★:B)	
Q532	8-729-141-26	TRANSISTOR 2SC3622A-LK (★:B)	
Q1004	8-729-900-36	TRANSISTOR DTC124ES (*1)	
Q1005	8-729-119-76	TRANSISTOR 2SA1175-HFE (*1)	
Q1204	8-729-900-63	TRANSISTOR DTA124ES	
Q1302	8-729-209-15	TRANSISTOR 2SD2012	
Q1304	8-729-620-05	TRANSISTOR 2SC2603-EF (*2, D259)	
Q1304	8-729-119-78	TRANSISTOR 2SC2785-HFE (*1, D209)	
Q1305	8-729-620-05	TRANSISTOR 2SC2603-EF (*2, D259)	
Q1305	8-729-119-78	TRANSISTOR 2SC2785-HFE (*1, D209)	
< RESISTOR >			
R301	1-249-401-11	CARBON 47 5% 1/4W F	
R302	1-249-409-11	CARBON 220 5% 1/4W F (*1)	
R302	1-249-413-11	CARBON 470 5% 1/4W F (*2, 3, 5)	
R302	1-249-407-11	CARBON 150 5% 1/4W F	
			(*7, 9, 10, 11)
R302	1-249-405-11	CARBON 100 5% 1/4W F (★:A)	
R303	1-249-411-11	CARBON 330 5% 1/4W (★:A)	
R304	1-249-432-11	CARBON 18K 5% 1/4W (★:A)	
R305	1-249-411-11	CARBON 330 5% 1/4W (★:A)	
R306	1-249-434-11	CARBON 27K 5% 1/4W (★:A)	

Ref. No.	Part No.	Description	Remarks
R307	1-249-414-11	CARBON 560 5% 1/4W F (★:A)	
R308	1-249-411-11	CARBON 330 5% 1/4W	
R309	1-249-432-11	CARBON 18K 5% 1/4W (EXCEPT *1)	
R310	1-249-411-11	CARBON 330 5% 1/4W	
R311	1-249-434-11	CARBON 27K 5% 1/4W (EXCEPT *1)	
R311	1-247-891-00	CARBON 330K 5% 1/4W (*1)	
R312	1-249-414-11	CARBON 560 5% 1/4W F	
			(*2, 3, 5, 7, 9, 11)
R312	1-249-416-11	CARBON 820 5% 1/4W F (★:A)	
R313	1-249-405-11	CARBON 100 5% 1/4W F	
R314	1-249-437-11	CARBON 47K 5% 1/4W (★:A)	
R315	1-249-404-00	CARBON 82 5% 1/4W	
R315	1-249-435-11	CARBON 33K 5% 1/4W (★:A)	
R316	1-249-429-11	CARBON 10K 5% 1/4W	
R317	1-249-417-11	CARBON 1K 5% 1/4W F	
R318	1-249-435-11	CARBON 33K 5% 1/4W	
R319	1-249-428-11	CARBON 8.2K 5% 1/4W F	
R320	1-249-432-11	CARBON 18K 5% 1/4W	
R321	1-249-423-11	CARBON 3.3K 5% 1/4W F	
R322	1-249-429-11	CARBON 10K 5% 1/4W	
R323	1-249-418-11	CARBON 1.2K 5% 1/4W F	
			(EXCEPT ★:A)
R323	1-249-423-11	CARBON 3.3K 5% 1/4W F (*4, 6)	
R323	1-249-417-11	CARBON 1K 5% 1/4W F (*8)	
R324	1-249-429-11	CARBON 10K 5% 1/4W	
R325	1-249-429-11	CARBON 10K 5% 1/4W	
R326	1-249-409-11	CARBON 220 5% 1/4W F	
R327	1-249-437-11	CARBON 47K 5% 1/4W	
R328	1-249-437-11	CARBON 47K 5% 1/4W	
R331	1-247-899-11	CARBON 680K 5% 1/4W	
R332	1-247-899-11	CARBON 680K 5% 1/4W	
R333	1-249-421-11	CARBON 2.2K 5% 1/4W F	
R334	1-249-421-11	CARBON 2.2K 5% 1/4W F	
R335	1-249-420-11	CARBON 1.8K 5% 1/4W F	
R336	1-249-420-11	CARBON 1.8K 5% 1/4W F	
R337	1-249-426-11	CARBON 5.6K 5% 1/4W	
R338	1-249-426-11	CARBON 5.6K 5% 1/4W	
R351	1-249-433-11	CARBON 22K 5% 1/4W (★:B)	
R352	1-249-437-11	CARBON 47K 5% 1/4W (★:B)	
R353	1-247-903-00	CARBON 1M 5% 1/4W (★:B)	
R354	1-249-441-11	CARBON 100K 5% 1/4W (★:B)	
R355	1-249-433-11	CARBON 22K 5% 1/4W (★:B)	
R356	1-249-421-11	CARBON 2.2K 5% 1/4W F (★:B)	
R361	1-249-437-11	CARBON 47K 5% 1/4W	
R362	1-249-437-11	CARBON 47K 5% 1/4W	
R363	1-249-425-11	CARBON 4.7K 5% 1/4W F (★:B)	
R364	1-249-425-11	CARBON 4.7K 5% 1/4W F (★:B)	
R365	1-249-429-11	CARBON 10K 5% 1/4W	
			(D209, *8, 9, 10)
R366	1-249-413-11	CARBON 470 5% 1/4W F (★:B)	
R367	1-249-434-11	CARBON 27K 5% 1/4W (★:B)	
R368	1-249-433-11	CARBON 22K 5% 1/4W (★:B)	
R370	1-249-423-11	CARBON 3.3K 5% 1/4W F (★:A)	

MAIN

SURROUND

Ref. No.	Part No.	Description	Remarks
R501	1-249-417-11	CARBON 1K 5% 1/4W F	
R502	1-249-417-11	CARBON 1K 5% 1/4W F	
R503	1-249-417-11	CARBON 1K 5% 1/4W F	
R504	1-249-417-11	CARBON 1K 5% 1/4W F	
R505	1-249-429-11	CARBON 10K 5% 1/4W	
R506	1-249-417-11	CARBON 1K 5% 1/4W F	
R510	1-249-401-11	CARBON 47 5% 1/4W F	
R511	1-249-429-11	CARBON 10K 5% 1/4W	
R512	1-249-425-11	CARBON 4.7K 5% 1/4W F	
R513	1-249-417-11	CARBON 1K 5% 1/4W F	
R514	1-249-429-11	CARBON 10K 5% 1/4W	
R515	1-249-417-11	CARBON 1K 5% 1/4W F	
R521	1-249-423-11	CARBON 3.3K 5% 1/4W F	
R522	1-249-425-11	CARBON 4.7K 5% 1/4W F	
R523	1-249-414-11	CARBON 560 5% 1/4W F	
R524	1-249-417-11	CARBON 1K 5% 1/4W F	
R525	1-249-410-11	CARBON 270 5% 1/4W F	
R526	1-249-421-11	CARBON 2.2K 5% 1/4W F	
R527	1-249-425-11	CARBON 4.7K 5% 1/4W F	
R528	1-249-425-11	CARBON 4.7K 5% 1/4W F	
R529	1-249-405-11	CARBON 100 5% 1/4W F	
R530	1-249-405-11	CARBON 100 5% 1/4W F	
R531	1-249-423-11	CARBON 3.3K 5% 1/4W F (★:B)	
R532	1-249-433-11	CARBON 22K 5% 1/4W (★:B)	
R533	1-249-414-11	CARBON 560 5% 1/4W F (★:B)	
R534	1-249-417-11	CARBON 1K 5% 1/4W F (★:B)	
R535	1-249-410-11	CARBON 270 5% 1/4W F (★:B)	
R536	1-249-421-11	CARBON 2.2K 5% 1/4W F (★:B)	
R537	1-249-425-11	CARBON 4.7K 5% 1/4W F (★:B)	
R538	1-249-405-11	CARBON 100 5% 1/4W F (★:B)	
R613	1-249-441-11	CARBON 100K 5% 1/4W (*9, 10, 11)	
R631	1-249-441-11	CARBON 100K 5% 1/4W (A27, D209, *8)	
R1001	1-249-417-11	CARBON 1K 5% 1/4W F	
R1002	1-249-441-11	CARBON 100K 5% 1/4W	
R1003	1-249-416-11	CARBON 820 5% 1/4W F	
R1004	1-247-897-11	CARBON 560K 5% 1/4W	
R1005	1-249-437-11	CARBON 47K 5% 1/4W	
R1006	1-249-409-11	CARBON 220 5% 1/4W F	
R1007	1-249-441-11	CARBON 100K 5% 1/4W	
R1008	1-249-409-11	CARBON 220 5% 1/4W F	
R1010	1-249-417-11	CARBON 1K 5% 1/4W F	
R1012	1-249-417-11	CARBON 1K 5% 1/4W F	
R1013	1-249-441-11	CARBON 100K 5% 1/4W	
R1014	1-249-437-11	CARBON 47K 5% 1/4W	
R1015	1-249-437-11	CARBON 47K 5% 1/4W	
R1021	1-249-437-11	CARBON 47K 5% 1/4W	
R1022	1-249-432-11	CARBON 18K 5% 1/4W (A27)	

Ref. No.	Part No.	Description	Remarks
R1023	1-249-437-11	CARBON 47K 5% 1/4W	
R1024	1-249-417-11	CARBON 1K 5% 1/4W F	
R1029	1-249-433-11	CARBON 22K 5% 1/4W (*1)	
R1030	1-249-433-11	CARBON 22K 5% 1/4W (*1)	
R1031	1-249-433-11	CARBON 22K 5% 1/4W (*1)	
R1035	1-249-415-11	CARBON 680 5% 1/4W F	
R1037	1-249-421-11	CARBON 2.2K 5% 1/4W F	
R1051	1-249-417-11	CARBON 1K 5% 1/4W F	
R1052	1-249-441-11	CARBON 100K 5% 1/4W	
R1053	1-249-416-11	CARBON 820 5% 1/4W F	
R1054	1-247-897-11	CARBON 560K 5% 1/4W	
R1055	1-249-437-11	CARBON 47K 5% 1/4W	
R1056	1-249-409-11	CARBON 220 5% 1/4W F	
R1057	1-249-441-11	CARBON 100K 5% 1/4W	
R1058	1-249-409-11	CARBON 220 5% 1/4W F	
R1060	1-249-417-11	CARBON 1K 5% 1/4W F	
R1062	1-249-417-11	CARBON 1K 5% 1/4W F	
R1063	1-249-441-11	CARBON 100K 5% 1/4W	
R1065	1-249-415-11	CARBON 680 5% 1/4W F	
R1071	1-249-437-11	CARBON 47K 5% 1/4W	
R1072	1-249-432-11	CARBON 18K 5% 1/4W (A27)	
R1073	1-249-437-11	CARBON 47K 5% 1/4W	
R1074	1-249-417-11	CARBON 1K 5% 1/4W F	
R1095	1-249-433-11	CARBON 22K 5% 1/4W (A27, *11)	
R1222	1-249-415-11	CARBON 680 5% 1/4W F	
R1223	1-249-415-11	CARBON 680 5% 1/4W F	
R1226	1-215-890-11	METAL OXIDE 470 5% 2W F	
R1233	1-249-433-11	CARBON 22K 5% 1/4W	
R1234	1-249-433-11	CARBON 22K 5% 1/4W	
R1235	1-249-437-11	CARBON 47K 5% 1/4W	
R1236	1-249-441-11	CARBON 100K 5% 1/4W	
R1237	1-249-429-11	CARBON 10K 5% 1/4W	
R1240	1-249-438-11	CARBON 56K 5% 1/4W	
R1241	1-249-385-11	CARBON 2.2 5% 1/6W F (★:A)	
R1242	1-249-385-11	CARBON 2.2 5% 1/6W F (★:A)	
R1243	1-249-385-11	CARBON 2.2 5% 1/6W F (★:A)	
R1244	1-249-385-11	CARBON 2.2 5% 1/6W F (★:A)	
R1272	1-249-415-11	CARBON 680 5% 1/4W F	
R1273	1-249-415-11	CARBON 680 5% 1/4W F	
R1290	1-249-437-11	CARBON 47K 5% 1/4W	
R1301	1-249-429-11	CARBON 10K 5% 1/4W	
R1302	1-249-429-11	CARBON 10K 5% 1/4W	
R1306	1-249-433-11	CARBON 22K 5% 1/4W	
R1309	1-249-433-11	CARBON 22K 5% 1/4W	
R1321	1-249-417-11	CARBON 1K 5% 1/4W F	
R1322	1-249-429-11	CARBON 10K 5% 1/4W	
R1345	1-249-421-11	CARBON 2.2K 5% 1/4W F	
R1346	1-249-425-11	CARBON 4.7K 5% 1/4W F (★:C)	
R1347	1-249-417-11	CARBON 1K 5% 1/4W F	

MAIN	SURROUND	PANEL	H. P	POWER SUPPLY (B)	MIC	STAND-BY	VR
-------------	-----------------	--------------	-------------	-------------------------	------------	-----------------	-----------

Ref. No.	Part No.	Description	Remarks
		< VARIABLE RESISTOR >	
RV301	1-238-601-11	RES, ADJ, CARBON 22K	
RV302	1-238-601-11	RES, ADJ, CARBON 22K	
		< RELAY >	
RY1201	1-515-533-11	RELAY	
RY1201	1-515-920-11	RELAY (24V) (D209, *8)	
		< TRANSFORMER >	
T301	1-404-807-11	TRANSFORMER, DISCRIMINATOR	
T302	1-235-126-00	ENCAPSULATED COMPONENT (★:A)	
		< TERMINAL >	
TM301	1-537-264-11	TERMINAL BOARD (ANTENNA) (A27, *3, 10, 11)	
* TM301	1-537-288-11	TERMINAL BOARD, ANTENNA (PAL) (ANTENNA) (*4, 5, 6, 7, 8, 9)	
		< TEST PIN >	
* TP1	1-560-060-00	PIN, CONNECTOR 2P	
		< VIBRATOR >	
XT501	1-577-126-21	VIBRATOR, CRYSTAL	
XT501	1-579-383-11	VIBRATOR, CRYSTAL	

* A-4356-640-A	PANEL BOARD, COMPLETE (*1) *****		
* A-4356-736-A	PANEL BOARD, COMPLETE (*2) *****		
* A-4356-623-A	PANEL BOARD, COMPLETE (*3) *****		
* A-4356-930-A	PANEL BOARD, COMPLETE (*4) *****		
* A-4360-822-A	PANEL BOARD, COMPLETE (*5) *****		
* A-4356-924-A	PANEL BOARD, COMPLETE (*6) *****		
* A-4356-608-A	PANEL BOARD, COMPLETE (*7) *****		
* A-4360-541-A	PANEL BOARD, COMPLETE (*8) *****		
* A-4360-531-A	PANEL BOARD, COMPLETE (*9) *****		
* A-4360-520-A	PANEL BOARD, COMPLETE (*10) *****		
* A-4360-509-A	PANEL BOARD, COMPLETE (*11) *****		
* 1-646-477-11	H. P BOARD *****		

Ref. No.	Part No.	Description	Remarks
*	1-646-478-11	POWER SUPPLY (B) BOARD *****	
*	1-646-479-11	MIC BOARD (A27) *****	
*	1-646-480-11	STAND-BY SW BOARD *****	
*	1-646-497-11	VR BOARD *****	
*	1-533-213-11	HOLDER, FUSE (*2, D259)	
*	1-533-213-31	HOLDER, FUSE (*2, D259)	
	1-533-217-31	HOLDER, FUSE (D209)	
*	1-533-293-11	FUSE HOLDER (*2, D259)	
*	4-942-301-01	HOLDER, FL TUBE	
*	4-949-935-31	CUSHION (FL) (*2, D259)	
		< CAPACITOR >	
C603	1-136-169-00	FILM 0.22uF	5% 50V
C604	1-164-159-11	CERAMIC 0.1uF	50V
C605	1-125-486-11	DOUBLE LAYERS 0.22F	5.5V
C606	1-164-159-11	CERAMIC 0.1uF	50V
C607	1-124-907-11	ELECT 10uF	20% 50V
C608	1-161-379-00	CERAMIC 0.01uF	20% 25V
C609	1-161-379-00	CERAMIC 0.01uF	20% 25V
C610	1-162-286-31	CERAMIC 220PF	10% 50V
C650	1-124-907-11	ELECT 10uF	20% 50V
C1101	1-124-257-00	ELECT 2.2uF	20% 50V
C1102	1-124-589-11	ELECT 47uF	20% 16V
C1103	1-162-282-31	CERAMIC 100PF	10% 50V
C1104	1-124-257-00	ELECT 2.2uF	20% 50V
C1105	1-124-464-11	ELECT 0.22uF	20% 50V
C1106	1-136-161-00	FILM 0.047uF	5% 50V
C1107	1-136-155-00	FILM 0.015uF	5% 50V
C1108	1-136-155-00	FILM 0.015uF	5% 50V
C1109	1-137-437-11	FILM 0.0056uF	5% 50V
C1110	1-161-327-00	CERAMIC 0.0033uF	20% 16V
C1111	1-136-155-00	FILM 0.015uF	5% 50V
C1112	1-136-157-00	FILM 0.022uF	5% 50V
C1113	1-136-153-00	FILM 0.01uF	5% 50V
C1114	1-161-377-00	CERAMIC 0.0047uF	20% 16V
C1115	1-124-257-00	ELECT 2.2uF	20% 50V
C1120	1-161-379-00	CERAMIC 0.01uF	20% 25V
C1121	1-161-379-00	CERAMIC 0.01uF	20% 25V
C1123	1-162-286-31	CERAMIC 220PF	10% 50V
C1131	1-162-215-31	CERAMIC 47PF	5% 50V
C1132	1-162-215-31	CERAMIC 47PF	5% 50V
C1151	1-124-257-00	ELECT 2.2uF	20% 50V
C1152	1-124-589-11	ELECT 47uF	20% 16V
C1153	1-162-282-31	CERAMIC 100PF	10% 50V
C1154	1-124-257-00	ELECT 2.2uF	20% 50V

PANEL	H. P	POWER SUPPLY (B)	MIC	STAND-BY	VR
-------	------	------------------	-----	----------	----

Ref. No.	Part No.	Description	Remarks
C1155	1-124-464-11	ELECT	0. 22uF 20% 50V
C1156	1-136-161-00	FILM	0. 047uF 5% 50V
C1157	1-136-155-00	FILM	0. 015uF 5% 50V
C1158	1-136-155-00	FILM	0. 015uF 5% 50V
C1159	1-137-437-11	FILM	0. 0056uF 5% 50V
C1160	1-161-327-00	CERAMIC	0. 0033uF 20% 16V
C1161	1-136-155-00	FILM	0. 015uF 5% 50V
C1162	1-136-157-00	FILM	0. 022uF 5% 50V
C1163	1-136-153-00	FILM	0. 01uF 5% 50V
C1164	1-161-377-00	CERAMIC	0. 0047uF 20% 16V
C1165	1-124-257-00	ELECT	2. 2uF 20% 50V
C1173	1-162-286-31	CERAMIC	220PF 10% 50V
C1181	1-162-215-31	CERAMIC	47PF 5% 50V
C1182	1-162-215-31	CERAMIC	47PF 5% 50V
C1198	1-161-379-00	CERAMIC	0. 01uF 20% 25V
C1237	1-162-282-31	CERAMIC	100PF 10% 50V (★:A)
C1238	1-162-282-31	CERAMIC	100PF 10% 50V (★:A)
C1401	1-162-294-31	CERAMIC	0. 001uF 10% 50V (A27)
C1402	1-124-916-11	ELECT	22uF 20% 63V (A27)
C1403	1-124-916-11	ELECT	22uF 20% 63V (A27)
C1406	1-124-443-00	ELECT	100uF 20% 10V (*2)
C1408	1-126-163-11	ELECT	4. 7uF 20% 50V (A27)
C1409	1-161-379-00	CERAMIC	0. 01uF 20% 25V (A27)
C1410	1-126-163-11	ELECT	4. 7uF 20% 50V (A27, D259)
C1411	1-124-443-00	ELECT	100uF 20% 10V (*1)
C1601	1-124-925-11	ELECT	2. 2uF 20% 100V (A27)
C1602	1-124-463-00	ELECT	0. 1uF 20% 50V (A27)
C1603	1-124-925-11	ELECT	2. 2uF 20% 100V (A27)
C1604	1-162-294-31	CERAMIC	0. 001uF 10% 50V (A27)
C1605	1-162-215-31	CERAMIC	47PF 5% 50V (A27)
C1606	1-162-282-31	CERAMIC	100PF 10% 50V (A27)
C1607	1-162-215-31	CERAMIC	47PF 5% 50V (A27)
C1608	1-124-589-11	ELECT	47uF 20% 16V (A27)
C1609	1-124-589-11	ELECT	47uF 20% 16V (A27)
C1610	1-162-282-31	CERAMIC	100PF 10% 50V (A27)

< CONNECTOR >

* CN601	1-568-830-11	SOCKET, CONNECTOR	11P
CN1101	1-568-802-11	SOCKET, CONNECTOR	19P

< DIODE >

D601	8-719-987-63	DIODE	1N4148M
D602	8-719-010-26	DIODE	UZ-3. 9BSB
D603	8-719-987-63	DIODE	1N4148M
D604	8-719-987-63	DIODE	1N4148M
D605	8-719-987-63	DIODE	1N4148M
D606	8-719-933-48	DIODE	HZS7B3L
D611	8-719-987-63	DIODE	1N4148M
D612	8-719-987-63	DIODE	1N4148M
D613	8-719-987-63	DIODE	1N4148M

Ref. No.	Part No.	Description	Remarks
D614	8-719-987-63	DIODE	1N4148M
D615	8-719-987-63	DIODE	1N4148M
D616	8-719-987-63	DIODE	1N4148M
D622	8-719-987-63	DIODE	1N4148M (*1, 4, 8, 11)
D623	8-719-987-63	DIODE	1N4148M (A27, *11)
D624	8-719-987-63	DIODE	1N4148M (*5)
D625	8-719-987-63	DIODE	1N4148M
D626	8-719-987-63	DIODE	1N4148M
D629	8-719-987-63	DIODE	1N4148M
D641	8-719-200-82	DIODE	11ES2
D1130	8-719-301-37	LED	SEL2210S-CD
D1131	8-719-301-37	LED	SEL2210S-CD
D1132	8-719-301-37	LED	SEL2210S-CD
D1133	8-719-301-37	LED	SEL2210S-CD
D1134	8-719-301-37	LED	SEL2210S-CD
D1141	8-719-301-37	LED	SEL2210S-CD
D1145	8-719-313-69	DIODE	SEL3210S-CD
D1151	8-719-987-63	DIODE	1N4148M
D1152	8-719-987-63	DIODE	1N4148M
D1153	8-719-987-63	DIODE	1N4148M
D1154	8-719-987-63	DIODE	1N4148M

< FILTER >

FL601	1-519-732-11	INDICATOR TUBE, FLUORESCENT
FL1401	1-519-648-21	INDICATOR TUBE, FLUORESCENT (A27)

< IC >

IC601	8-759-096-99	IC	uPD75212ACW-A47
IC602	8-749-922-36	IC	GP1U50XB
IC1101	8-759-634-51	IC	M5218AP
IC1102	8-759-634-51	IC	M5218AP
IC1103	8-759-820-62	IC	LB1639
IC1104	8-759-916-12	IC	TC74HC00P
IC1401	8-759-065-87	IC	XR-1096 (A27)
IC1601	8-759-634-51	IC	M5218AP (A27)

< JACK >

J601	1-691-002-11	JACK, LARGE TYPE (HEADPHONES) (*2)
J601	1-573-151-11	JACK, LARGE TYPE (HEADPHONES) (*1)
* J1201	1-691-003-11	JACK, LARGE TYPE (MIC)

< COIL >

L601	1-410-521-11	INDUCTOR	100uH
------	--------------	----------	-------

< TRANSISTOR >

Q601	8-729-620-05	TRANSISTOR	2SC2603-EF (*2, D259)
Q601	8-729-119-78	TRANSISTOR	2SC2785-HFE (*1, D209)
Q602	8-729-900-80	TRANSISTOR	DTC114ES
Q603	8-729-900-80	TRANSISTOR	DTC114ES
Q1101	8-729-620-05	TRANSISTOR	2SC2603-EF (*2, D259)

PANEL	H. P	POWER SUPPLY (B)	MIC	STAND-BY	VR
-------	------	------------------	-----	----------	----

Ref. No.	Part No.	Description	Remarks	Ref. No.	Part No.	Description	Remarks
Q1101	8-729-119-78	TRANSISTOR	2SC2785-HFE (*1, D209)	R1114	1-249-429-11	CARBON	10K 5% 1/4W
Q1102	8-729-141-26	TRANSISTOR	2SC3622A-LK	R1115	1-249-429-11	CARBON	10K 5% 1/4W
Q1121	8-729-900-36	TRANSISTOR	DTC124ES	R1116	1-247-852-11	CARBON	7.5K 5% 1/4W
Q1122	8-729-119-76	TRANSISTOR	2SA1175-HFE	R1117	1-247-852-11	CARBON	7.5K 5% 1/4W
Q1136	8-729-900-36	TRANSISTOR	DTC124ES	R1118	1-249-425-11	CARBON	4.7K 5% 1/4W F
Q1138	8-729-900-36	TRANSISTOR	DTC124ES	R1119	1-249-425-11	CARBON	4.7K 5% 1/4W F
Q1141	8-729-900-63	TRANSISTOR	DTA124ES	R1120	1-249-423-11	CARBON	3.3K 5% 1/4W F
Q1142	8-729-900-63	TRANSISTOR	DTA124ES	R1121	1-249-423-11	CARBON	3.3K 5% 1/4W F
Q1143	8-729-900-80	TRANSISTOR	DTC114ES	R1122	1-247-887-00	CARBON	220K 5% 1/4W
Q1144	8-729-900-80	TRANSISTOR	DTC114ES	R1123	1-249-421-11	CARBON	2.2K 5% 1/4W F
Q1145	8-729-900-61	TRANSISTOR	DTA114ES	R1124	1-249-425-11	CARBON	4.7K 5% 1/4W F
Q1151	8-729-620-05	TRANSISTOR	2SC2603-EF (*2, D259)	R1125	1-249-433-11	CARBON	22K 5% 1/4W
Q1151	8-729-119-78	TRANSISTOR	2SC2785-HFE (*1, D209)	R1126	1-249-423-11	CARBON	3.3K 5% 1/4W F (A27)
Q1152	8-729-141-26	TRANSISTOR	2SC3622A-LK	R1127	1-249-436-11	CARBON	39K 5% 1/4W (A27)
				R1130	1-249-412-11	CARBON	390 5% 1/4W F
		< RESISTOR >					
R601	1-249-429-11	CARBON	10K 5% 1/4W	R1132	1-249-412-11	CARBON	390 5% 1/4W F
R602	1-249-429-11	CARBON	10K 5% 1/4W	R1133	1-249-412-11	CARBON	390 5% 1/4W F
R603	1-249-423-11	CARBON	3.3K 5% 1/4W F	R1135	1-249-433-11	CARBON	22K 5% 1/4W
R604	1-249-437-11	CARBON	47K 5% 1/4W (*4, 8)	R1142	1-249-412-11	CARBON	390 5% 1/4W F
R605	1-249-433-11	CARBON	22K 5% 1/4W	R1143	1-249-433-11	CARBON	22K 5% 1/4W
R606	1-249-433-11	CARBON	22K 5% 1/4W	R1145	1-249-412-11	CARBON	390 5% 1/4W F
R607	1-249-439-11	CARBON	68K 5% 1/4W	R1149	1-249-429-11	CARBON	10K 5% 1/4W
R608	1-249-417-11	CARBON	1K 5% 1/4W F	R1151	1-249-441-11	CARBON	100K 5% 1/4W
R609	1-249-405-11	CARBON	100 5% 1/4W F	R1152	1-249-417-11	CARBON	1K 5% 1/4W F
R610	1-249-429-11	CARBON	10K 5% 1/4W	R1154	1-249-441-11	CARBON	100K 5% 1/4W
R611	1-249-437-11	CARBON	47K 5% 1/4W	R1155	1-249-433-11	CARBON	22K 5% 1/4W
R612	1-249-417-11	CARBON	1K 5% 1/4W F	R1156	1-249-424-11	CARBON	3.9K 5% 1/4W F
R613	1-249-425-11	CARBON	4.7K 5% 1/4W F	R1157	1-249-441-11	CARBON	100K 5% 1/4W
R614	1-249-393-11	CARBON	10 5% 1/4W F	R1158	1-249-427-11	CARBON	6.8K 5% 1/4W F
R621	1-249-433-11	CARBON	22K 5% 1/4W	R1159	1-249-412-11	CARBON	390 5% 1/4W F
R622	1-249-433-11	CARBON	22K 5% 1/4W	R1160	1-249-431-11	CARBON	15K 5% 1/4W
R623	1-249-433-11	CARBON	22K 5% 1/4W	R1161	1-249-439-11	CARBON	68K 5% 1/4W
R624	1-249-433-11	CARBON	22K 5% 1/4W	R1162	1-249-433-11	CARBON	22K 5% 1/4W
R625	1-249-417-11	CARBON	1K 5% 1/4W F (*1, D259)	R1163	1-249-431-11	CARBON	15K 5% 1/4W
R642	1-249-409-11	CARBON	220 5% 1/4W F	R1164	1-249-429-11	CARBON	10K 5% 1/4W
R643	1-249-417-11	CARBON	1K 5% 1/4W F (*2, D209, 8, 10, 11)	R1165	1-249-429-11	CARBON	10K 5% 1/4W
R1065	1-249-409-11	CARBON	220 5% 1/4W F (*2)	R1166	1-247-852-11	CARBON	7.5K 5% 1/4W
R1101	1-249-441-11	CARBON	100K 5% 1/4W	R1167	1-247-852-11	CARBON	7.5K 5% 1/4W
R1102	1-249-417-11	CARBON	1K 5% 1/4W F	R1168	1-249-425-11	CARBON	4.7K 5% 1/4W F
R1103	1-249-431-11	CARBON	15K 5% 1/4W	R1169	1-249-425-11	CARBON	4.7K 5% 1/4W F
R1104	1-249-441-11	CARBON	100K 5% 1/4W	R1170	1-249-423-11	CARBON	3.3K 5% 1/4W F
R1105	1-249-433-11	CARBON	22K 5% 1/4W	R1171	1-249-423-11	CARBON	3.3K 5% 1/4W F
R1106	1-249-424-11	CARBON	3.9K 5% 1/4W F	R1172	1-247-887-00	CARBON	220K 5% 1/4W
R1107	1-249-441-11	CARBON	100K 5% 1/4W	R1173	1-249-421-11	CARBON	2.2K 5% 1/4W F
R1108	1-249-427-11	CARBON	6.8K 5% 1/4W F	R1174	1-249-425-11	CARBON	4.7K 5% 1/4W F
R1109	1-249-412-11	CARBON	390 5% 1/4W F	R1176	1-249-423-11	CARBON	3.3K 5% 1/4W F (A27)
R1110	1-249-431-11	CARBON	15K 5% 1/4W	R1177	1-249-436-11	CARBON	39K 5% 1/4W (A27)
R1111	1-249-439-11	CARBON	68K 5% 1/4W	R1401	1-249-418-11	CARBON	1.2K 5% 1/4W F (A27)
R1112	1-249-433-11	CARBON	22K 5% 1/4W	R1402	1-247-881-00	CARBON	120K 5% 1/4W (A27)
R1113	1-249-431-11	CARBON	15K 5% 1/4W	R1403	1-247-881-00	CARBON	120K 5% 1/4W (A27)
				R1405	1-249-409-11	CARBON	220 5% 1/4W F (*1)

PANEL	H. P	POWER SUPPLY (B)	MIC	STAND-BY	VR	POWER AMPLIFIER
--------------	-------------	-------------------------	------------	-----------------	-----------	------------------------

Ref. No.	Part No.	Description	Remarks
R1411	1-239-054-11	COMPOSITION CIRCUIT BLOCK	(A27)
R1412	1-239-054-11	COMPOSITION CIRCUIT BLOCK	(A27)
R1601	1-249-429-11	CARBON 10K 5% 1/4W	(A27)
R1602	1-249-417-11	CARBON 1K 5% 1/4W F	(A27)
R1603	1-249-412-11	CARBON 390 5% 1/4W F	(A27)
R1604	1-249-434-11	CARBON 27K 5% 1/4W	(A27)
R1605	1-249-433-11	CARBON 22K 5% 1/4W	(A27)
R1606	1-249-437-11	CARBON 47K 5% 1/4W	(A27)
< VARIABLE RESISTOR >			
RV1101	1-223-251-11	RES, VAR, CARBON 100K/100K (SURROUND)	
RV1102	1-223-251-11	RES, VAR, CARBON 100K/100K (DBFB)	
RV1103	1-223-289-11	RES, VAR, SLIDE 100K (100Hz)	
RV1104	1-223-289-11	RES, VAR, SLIDE 100K (330Hz)	
RV1105	1-223-289-11	RES, VAR, SLIDE 100K (1KHz)	
RV1106	1-223-289-11	RES, VAR, SLIDE 100K (3.3KHz)	
RV1107	1-223-289-11	RES, VAR, SLIDE 100K (10KHz)	
RV1108	1-223-253-11	RES, VAR, CARBON 100K/100K (BALANCE)	
RV1109	1-223-291-11	RES, VAR, CARBON 100K/100K (VOLUME)	
RV1153	1-223-289-11	RES, VAR, SLIDE 100K (100Hz)	
RV1154	1-223-289-11	RES, VAR, SLIDE 100K (330Hz)	
RV1155	1-223-289-11	RES, VAR, SLIDE 100K (1KHz)	
RV1156	1-223-289-11	RES, VAR, SLIDE 100K (3.3KHz)	
RV1157	1-223-289-11	RES, VAR, SLIDE 100K (10KHz)	
< SWITCH >			
S601	1-554-303-21	SWITCH, TACTILE (1)	
S602	1-554-303-21	SWITCH, TACTILE (2)	
S603	1-554-303-21	SWITCH, TACTILE (3)	
S604	1-554-303-21	SWITCH, TACTILE (4)	
S605	1-554-303-21	SWITCH, TACTILE (5)	
S606	1-554-303-21	SWITCH, TACTILE (6)	
S607	1-554-303-21	SWITCH, TACTILE (7)	
S608	1-554-303-21	SWITCH, TACTILE (8)	
S609	1-554-303-21	SWITCH, TACTILE (9)	
S610	1-554-303-21	SWITCH, TACTILE (0)	
S611	1-554-303-21	SWITCH, TACTILE (+)	
S612	1-554-303-21	SWITCH, TACTILE (-)	
S613	1-554-303-21	SWITCH, TACTILE (SHIFT)	
S614	1-554-303-21	SWITCH, TACTILE (BAND SELECT)	
S615	1-554-303-21	SWITCH, TACTILE (ST/MUTE)	
S616	1-554-303-21	SWITCH, TACTILE (MEMORY)	
S618	1-554-303-21	SWITCH, TACTILE (SYSTEM POWER)	
S619	1-554-303-21	SWITCH, TACTILE (VIDEO) (A27, *4, D259)	
S620	1-554-303-21	SWITCH, TACTILE (TAPE)	
S621	1-554-303-21	SWITCH, TACTILE (CD)	
S622	1-554-303-21	SWITCH, TACTILE (TUNER)	
S623	1-554-303-21	SWITCH, TACTILE (PHONO)	
S1102	1-571-305-11	SWITCH, PUSH (EQUILIZER) (1 KEY)	

Ref. No.	Part No.	Description	Remarks
< VIBRATOR >			
X601	1-567-775-11	VIBRATOR, CERAMIC	

*	A-4356-649-A	POWER AMPLIFIER BOARD, COMPLETE (#1)	

*	A-4356-749-A	POWER AMPLIFIER BOARD, COMPLETE (#2)	

*	A-4356-628-A	POWER AMPLIFIER BOARD, COMPLETE (#3)	

*	A-4356-935-A	POWER AMPLIFIER BOARD, COMPLETE (#4, 6)	

*	A-4356-616-A	POWER AMPLIFIER BOARD, COMPLETE (#5, 7)	

*	A-4360-546-A	POWER AMPLIFIER BOARD, COMPLETE (#8)	

*	A-4360-537-A	POWER AMPLIFIER BOARD, COMPLETE (#9)	

*	A-4360-527-A	POWER AMPLIFIER BOARD, COMPLETE (#10)	

*	A-4360-516-A	POWER AMPLIFIER BOARD, COMPLETE (#11)	

< CAPACITOR >			
C1201	1-124-257-00	ELECT 2.2uF 20% 50V	
C1202	1-162-286-31	CERAMIC 220PF 10% 50V	(EXCEPT ★:A)
C1202	1-162-290-31	CERAMIC 470PF 10% 50V	(★:A)
C1203	1-162-286-31	CERAMIC 220PF 10% 50V	(EXCEPT ★:A)
C1203	1-162-292-31	CERAMIC 680PF 10% 50V	(★:A)
C1204	1-124-477-11	ELECT 47uF 20% 25V	
C1205	1-124-910-11	ELECT 47uF 20% 50V	
C1206	1-124-122-11	ELECT 100uF 20% 50V	
C1207	1-136-165-00	FILM 0.1uF 5% 50V	
C1208	1-124-916-11	ELECT 22uF 20% 63V	
C1209	1-164-159-11	CERAMIC 0.1uF 50V	
C1210	1-136-163-00	FILM 0.068uF 5% 50V	
C1211	1-136-163-00	FILM 0.068uF 5% 50V	
C1220	1-124-910-11	ELECT 47uF 20% 50V	
C1230	1-161-494-00	CERAMIC 0.022uF 25V	(★:A)
C1231	1-161-494-00	CERAMIC 0.022uF 25V	(★:A)
C1232	1-161-494-00	CERAMIC 0.022uF 25V	(★:A)
C1233	1-161-494-00	CERAMIC 0.022uF 25V	(★:A)
C1251	1-124-257-00	ELECT 2.2uF 20% 50V	
C1252	1-162-286-31	CERAMIC 220PF 10% 50V	(EXCEPT ★:A)
C1252	1-162-290-31	CERAMIC 470PF 10% 50V	(★:A)

POWER AMPLIFIER

POWER SUPPLY

Ref. No.	Part No.	Description	Remarks
C1253	1-162-286-31	CERAMIC 220PF 10% 50V	(EXCEPT ★:A)
C1253	1-162-292-31	CERAMIC 680PF 10% 50V	(★:A)
C1254	1-124-477-11	ELECT 47uF 20% 25V	
C1255	1-124-910-11	ELECT 47uF 20% 50V	
C1256	1-124-122-11	ELECT 100uF 20% 50V	
C1257	1-136-165-00	FILM 0.1uF 5% 50V	
C1260	1-136-163-00	FILM 0.068uF 5% 50V	
C1261	1-136-163-00	FILM 0.068uF 5% 50V	
C1280	1-161-494-00	CERAMIC 0.022uF 25V	(★:A)
< CONNECTOR >			
* CN1201	1-564-518-11	PLUG, CONNECTOR 3P	
* CN1202	1-564-522-11	PLUG, CONNECTOR 7P	
< DIODE >			
D1201	8-719-987-63	DIODE 1N4148M	
D1251	8-719-987-63	DIODE 1N4148M	
< IC >			
IC1201	8-749-900-24	IC STK-4162MK2 (A27, *11)	
IC1201	8-749-900-96	IC STK-4142MK2 (D209, *8, 9, 10)	
< COIL >			
L1221	1-420-872-00	COIL, AIR CORE	
L1251	1-420-872-00	COIL, AIR CORE	
< TRANSISTOR >			
Q1201	8-729-140-84	TRANSISTOR 2SC1841-PAFAEA	
Q1202	8-729-900-80	TRANSISTOR DTC114ES	
Q1203	8-729-620-05	TRANSISTOR 2SC2603-EF (*2, D259)	
Q1203	8-729-119-78	TRANSISTOR 2SC2785-HFE (*1, D209)	
Q1251	8-729-140-84	TRANSISTOR 2SC1841-PAFAEA	
< RESISTOR >			
R1201	1-249-417-11	CARBON 1K 5% 1/4W F	
R1202	1-249-438-11	CARBON 56K 5% 1/4W	
R1203	1-249-417-11	CARBON 1K 5% 1/4W F	
R1204	1-249-438-11	CARBON 56K 5% 1/4W	
R1205	1-249-425-11	CARBON 4.7K 5% 1/4W F	
R1206	1-249-425-11	CARBON 4.7K 5% 1/4W F	
R1207	1-249-425-11	CARBON 4.7K 5% 1/4W F	
R1208	1-249-425-11	CARBON 4.7K 5% 1/4W F	
△R1209	1-212-881-11	FUSIBLE 100 5% 1/4W F	
△R1210	1-217-151-00	RES, METAL PLATE 0.22	
R1211	1-249-417-11	CARBON 1K 5% 1/4W F	
R1212	1-249-431-11	CARBON 15K 5% 1/4W	
R1213	1-249-441-11	CARBON 100K 5% 1/4W	
R1214	1-249-421-11	CARBON 2.2K 5% 1/4W F	
R1215	1-249-421-11	CARBON 2.2K 5% 1/4W F	

Ref. No.	Part No.	Description	Remarks
R1216	1-249-421-11	CARBON 2.2K 5% 1/4W F	
R1217	1-249-421-11	CARBON 2.2K 5% 1/4W F	
R1218	1-249-397-11	CARBON 22 5% 1/4W F	
R1219	1-249-397-11	CARBON 22 5% 1/4W F	
R1220	1-249-397-11	CARBON 22 5% 1/4W F	
R1221	1-249-397-11	CARBON 22 5% 1/4W F	
R1227	1-249-429-11	CARBON 10K 5% 1/4W	
R1228	1-247-881-00	CARBON 120K 5% 1/4W	
R1229	1-249-439-11	CARBON 68K 5% 1/4W	
R1230	1-249-439-11	CARBON 68K 5% 1/4W	
R1231	1-249-417-11	CARBON 1K 5% 1/4W F	
R1232	1-249-428-11	CARBON 8.2K 5% 1/4W F	
R1238	1-249-433-11	CARBON 22K 5% 1/4W	
R1239	1-249-426-11	CARBON 5.6K 5% 1/4W	
R1241	1-249-383-81	CARBON 1.5 5% 1/4W F (*3, 5, 7)	
R1251	1-249-417-11	CARBON 1K 5% 1/4W F	
R1252	1-249-438-11	CARBON 56K 5% 1/4W	
R1253	1-249-417-11	CARBON 1K 5% 1/4W F	
R1254	1-249-438-11	CARBON 56K 5% 1/4W	
R1255	1-249-425-11	CARBON 4.7K 5% 1/4W F	
R1256	1-249-425-11	CARBON 4.7K 5% 1/4W F	
R1257	1-249-425-11	CARBON 4.7K 5% 1/4W F	
R1258	1-249-425-11	CARBON 4.7K 5% 1/4W F	
△R1259	1-212-881-11	FUSIBLE 100 5% 1/4W F	
△R1260	1-217-151-00	RES, METAL PLATE 0.22	
R1261	1-249-417-11	CARBON 1K 5% 1/4W F	
R1262	1-249-431-11	CARBON 15K 5% 1/4W	
R1263	1-249-441-11	CARBON 100K 5% 1/4W	
R1268	1-249-397-11	CARBON 22 5% 1/4W F	
R1269	1-249-397-11	CARBON 22 5% 1/4W F	
R1270	1-249-397-11	CARBON 22 5% 1/4W F	
R1271	1-249-397-11	CARBON 22 5% 1/4W F	

* 1-646-474-11 POWER SUPPLY BOARD

< CAPACITOR >

C1301	1-161-744-00	CERAMIC 0.01uF	400V
C1314	1-124-122-11	ELECT 100uF 20%	50V
C1315	1-124-927-11	ELECT 4.7uF 20%	100V
C1316	1-124-910-11	ELECT 47uF 20%	50V
C1318	1-124-636-00	ELECT 3300uF 20%	25V
C1348	1-164-159-11	CERAMIC 0.1uF	50V (*4, 5, 6, 7, D259)
C1362	1-124-916-11	ELECT 22uF 20%	63V

Note:
The components identified by mark △ or dotted line with mark △ are critical for safety. Replace only with part number specified.

Note:
Les composants identifiés par une marque △ sont critiques pour la sécurité. Ne les remplacer que par une pièce portant le numéro spécifié.

POWER SUPPLY

Ref. No.	Part No.	Description	Remarks
		< CONNECTOR >	
* CN1301	1-564-321-00	PIN, CONNECTOR 2P	
CN1311	1-506-468-11	PIN, CONNECTOR 3P	
		< DIODE >	
D1307	8-719-002-60	DIODE UZL-33L	
D1309	8-719-014-66	DIODE UZP-5.6B	
D1311	8-719-200-82	DIODE 11ES2	
D1370	8-719-200-82	DIODE 11ES2	
D1321	8-719-987-63	DIODE 1N4148M	
D1322	8-719-987-63	DIODE 1N4148M	
D1354	8-719-200-82	DIODE 11ES2	
D1355	8-719-200-82	DIODE 11ES2	
		< TRANSISTOR >	
Q1301	8-729-141-83	TRANSISTOR 2SA473	
		< RESISTOR >	
R1303	1-249-421-11	CARBON 2.2K 5% 1/4W F	
R1304	1-249-425-11	CARBON 4.7K 5% 1/4W F	
R1391	1-202-725-00	SOLID 3.3M 10% 1/2W (*11)	
		< RELAY >	
RY1301	1-515-720-11	RELAY	
RY1301	1-515-738-11	RELAY, POWER	
		< TRANSFORMER >	
△T1302	1-449-723-31	TRANSFORMER, POWER (EXCEPT *11)	
△T1302	1-450-786-11	TRANSFORMER, POWER (*11)	
		< VOLTAGE SELECTION >	
△VS1301	1-572-266-11	SWITCH, VOLTAGE SELECTION (A27)	

		MISCELLANEOUS	

18	1-590-578-11	WIRE, FLAT TYPE (19 CORE)	
19	1-590-576-11	WIRE, FLAT TYPE (11 CORE)	
19	1-590-576-21	WIRE, FLAT TYPE (11 CORE) (D209)	
△64	1-575-651-11	CORD, POWER (*4, , 5, 6, 7, 8, 9)	
△64	1-575-653-11	CORD, POWER (A27:E)	
△64	1-690-608-11	CORD, POWER (A27:AU2)	
△64	1-690-609-21	CORD, POWER (*11)	
△64	1-696-570-21	CORD, POWER (*3, 10)	
△64	1-696-848-21	CORD, POWER (*1)	
△F1301	1-532-350-00	FUSE 4A (A27, D209, *9, 10)	
△F1301	1-576-108-11	FUSE 4A (*8, 11)	
△F1302	1-532-350-00	FUSE 4A (A27, D209, *9, 10)	
△F1302	1-576-108-11	FUSE 4A (*8, 11)	

Ref. No.	Part No.	Description	Remarks
△F1303	1-532-203-00	FUSE 2A (D209, *9, 10)	
△F1303	1-532-286-00	FUSE 2.5A (A27, D209, *9, 10)	
△F1303	1-576-104-11	FUSE 2A (*8)	
△F1304	1-532-203-00	FUSE 2A (D209, *9, 10)	
△F1304	1-532-286-00	FUSE 2.5A (A27, D209, *9, 10)	
△F1304	1-576-104-11	FUSE 2A (*8)	
△F1305	1-532-286-00	FUSE 2.5A (A27, D209, *9, 10)	
△F1305	1-576-105-11	FUSE 2.5A (*8, 11)	
△F1306	1-532-286-00	FUSE 2.5A (A27, D209, *9, 10)	
△F1306	1-576-105-11	FUSE 2.5A (*8, 11)	
△T1301	1-423-431-11	TRANSFORMER, POWER (*11)	
△T1301	1-423-437-11	TRANSFORMER, POWER (D209)	
△T1301	1-423-437-21	TRANSFORMER, POWER (*8, 9, 10)	
△T1301	1-423-438-11	TRANSFORMER, POWER (*1)	
△T1301	1-423-438-21	TRANSFORMER, POWER (*2)	

		ACCESSORIES & PACKING MATERIALS	

		1-465-963-11	COMMANDER, STANDARD (RM-S271)
		1-501-374-11	ANTENNA, LOOP (*4, 5, 7, 8, D259:AE2)
		1-501-536-11	ANTENNA (*4, 5, 7, 8, D259:AE2)
*		1-696-860-11	CORD, CONNECTION 13P (*4, 5, 7, 8, D259:AE2)
*		3-703-713-41	STICKER, SONY SYMBOL (10)
		3-707-584-01	COVER, BATTERY
		3-756-331-41	MANUAL, INSTRUCTION (ENGLISH/FRENCH/ SPANISH/PORTUGUESE) (D209:AE2)
		3-756-331-51	MANUAL, INSTRUCTION (GERMANY/DUTCH/ SWEDISH/ITALIAN) (D209:AE2, *4)
		3-756-331-61	MANUAL, INSTRUCTION (DANISH/FINNISH) (*5)
		3-756-333-41	MANUAL, INSTRUCTION (ENGLISH/FRENCH/ SPANISH/PORTUGUESE) (D259:AE2)
		3-756-333-51	MANUAL, INSTRUCTION (GERMANY/DUTCH/ SWEDISH/ITALIAN) (D259:AE2, *8)
*		4-956-903-01	INDIVIDUAL CARTON (D209:AE2, *4)
*		4-958-606-01	CUSHION (D209:AE2, *4)

		HARDWARE LIST	

#1	7-685-646-79	SCREW +BVTP 3X8 TYPE2 N-S	
#2	7-685-871-01	SCREW +BVTT 3X6 (S)	

<p>Note: The components identified by mark △ or dotted line with mark △ are critical for safety. Replace only with part number specified.</p>	<p>Note: Les composants identifiés par une marque △ sont critiques pour la sécurité. Ne les remplacer que par une pièce portant le numéro spécifié.</p>
--	--