

STR-A37/D309/D359

SERVICE MANUAL

AEP Model
STR-D309/D359

UK Model
STR-D359

Australian Model
E Model
PX Model
STR-A37

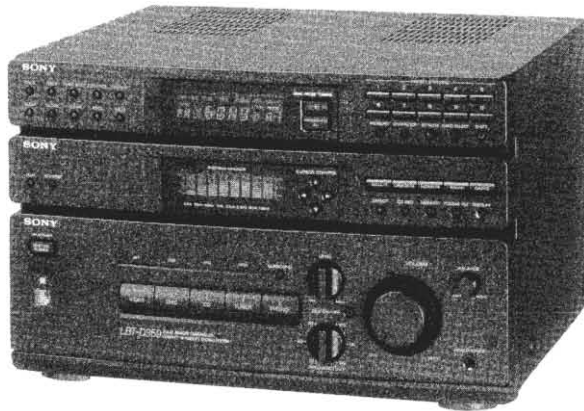

Photo is STR-D359

This set is the tuner and amplifier section in

STR-A37 : LBT-A37CDM
STR-D309 : LBT-D309CD
STR-D359 : LBT-D359CD

SPECIFICATIONS

• STR-A37

Tuner

System	FM stereo FM/AM superheterodyne tuner
FM tuner section	
Tuning range	87.5 to 108 MHz
Antenna	75 ohms unbalanced 300 ohms balanced
Intermediate frequency	10.7 MHz
AM tuner section	
Tuning range	531 to 1,602 kHz (at 9 kHz step) 530 to 1,710 kHz (at 10 kHz step)
Antenna	AM loop antenna External antenna terminal
Intermediate frequency	450 kHz

Amplifier

Peak music power output	700 W (6 ohms, 4 speakers driven)
Continuous RMS power output	55 W + 55 W (6 ohms, at 1 kHz, 5% THD)

Input	Jack type	Sensitivity	Impedance
VIDEO IN	Phono	300 mV	47 kohms
PHONO IN	Phono	3 mV	47 kohms
MIC	Phone	1 mV	10 kilohms

Output	Jack type	Impedance
SURROUND SPEAKER	Phono	Accepts speakers of 8 – 16 ohms
HEADPHONES	Stereophone	Accepts headphones of 8 ohms or more

Frequency response VIDEO: 15 Hz to 50 kHz $^{+0}_{-3}$ dB

General

Power requirements	110 – 120 V/220 – 240 V AC, adjustable with the VOLTAGE SELECTOR, 50/60 Hz
Power consumption	155 W
Mass	Approx. 7.3 kg
Dimensions	Approx. 355 × 225 × 330 mm (w/h/d, including projections)

• STR-D309/D359

Tuner

System	FM stereo FM/AM superheterodyne tuner
FM tuner section	65.0 to 74.0 MHz (East European model)
Tuning range	87.5 to 108 MHz
Antenna	75 ohms unbalanced
Intermediate frequency	10.7 MHz
AM tuner section	
Tuning range	(German model) 531 to 1,602 kHz (Italian model) 522 to 1,611 kHz (Other models) MW: 531 to 1,602 kHz LW: 153 to 279 kHz
Antenna	AM loop antenna External antenna terminal
Intermediate frequency	450 kHz

— Continued on next page —

STEREO FM-AM RECEIVER
SONY®



Amplifier

DIN power output 50 W + 50 W (6 ohms, at 1 kHz)
 Continuous RMS power output 60 W + 60 W (6 ohms, at 1 kHz, 5% THD)
 Music power output 90 W + 90 W (6 ohms)

Input	Jack type	Sensitivity	Impedance
VIDEO IN	Phono	300 mV	47 kohms
PHONO IN	Phono	3 mV	47 kohms

Output	Jack type	Impedance
SURROUND SPEAKER	Phono	Accepts speakers of 16 ohms
HEADPHONES	Stereophone	Accepts headphones of 8 ohms or more

Frequency response VIDEO: 15 Hz to 50 kHz $^{+0}_{-3}$ dB
 Power requirements 220 – 230 V AC, 50/60 Hz
 Power consumption 150 W
 Mass Approx. 7.3 kg
 Dimensions Approx. 355 × 225 × 330 mm (w/h/d, including projections)

Note on Ceramic Filter (CF301, ▲302, 303) Replacement. (PANEL BOARD : D609, D610)

This set employs two ceramic filters (CF301, ▲302, 303) which should have the same color marking to identify their center frequency. therefore FM IF offset adjustment by (*A, *B) connection is necessary to match the center frequency of the ceramic filters used with FM intermediate frequency.

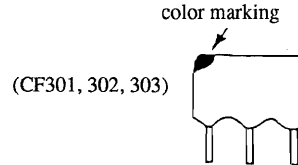

▲CF302 : G, IT model

○ : short
 X : open

Ceramic filter		Connection		FM intermediate frequency (MHz)
Color mark	Center frequency (MHz)	*A (D610)	*B (D609)	
White	10.750	X	○	10.750
Red	10.700	X	X	10.700
Black	10.650	○	X	10.650

MODEL IDENTIFICATION

— Model Number Portion — STR-A37, D309, D359

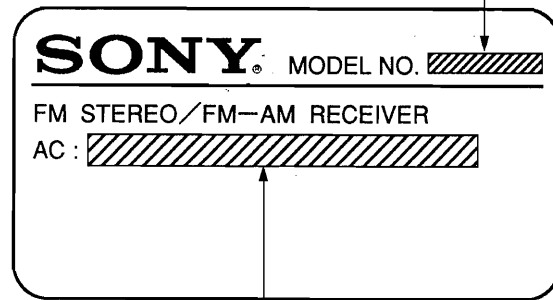

AEP, G, IT, EE, CIS Model: 220-230V~50/60Hz 150W
 UK Model: 240V~50Hz
 E, AUS, PX Model: 110-120V/220-240V~50/60Hz 155W

Note:

- G model : Germany model
- IT model : Italian model
- EE model : East European model
- AUS model : Australian model

SAFETY-RELATED COMPONENT WARNING!!

COMPONENTS IDENTIFIED BY MARK ▲ OR DOTTED LINE WITH MARK ▲ ON THE SCHEMATIC DIAGRAMS AND IN THE PARTS LIST ARE CRITICAL TO SAFE OPERATION. REPLACE THESE COMPONENTS WITH SONY PARTS WHOSE PART NUMBERS APPEAR AS SHOWN IN THIS MANUAL OR IN SUPPLEMENTS PUBLISHED BY SONY.

TABLE OF CONTENTS

<u>Section</u>	<u>Title</u>	<u>Page</u>
SECTION 1 GENERAL		
	Location of Controls	4
SECTION 2. ADJUSTMENTS		
5		
SECTION 3. DIAGRAMS		
3-1.	Circuit Boards Location	6
3-2.	Block Diagram	7
3-3.	Schematic Diagram	
	• TUNER Section	
	(STR-D309 : AEP, EE, CIS) (STR-D359 : AEP, UK)	11
3-4.	Printed Wiring Board	
	• TUNER Section	
	(STR-D309 : AEP, EE, CIS) (STR-D359 : AEP, UK)	13
3-5.	Schematic Diagram	
	• TUNER Section (STR-D309 : G, IT) (STR-D359 : IT)	15
3-6.	Printed Wiring Board	
	• TUNER Section (STR-D309 : G, IT) (STR-D359 : IT)	17
3-7.	Schematic Diagram	
	• TUNER Section (STR-A37)	19
3-8.	Printed Wiring Board	
	• TUNER Section (STR-A37)	21
3-9.	Printed Wiring Board	
	• MAIN Section (STR-D309/D359)	23
3-10.	Schematic Diagram	
	• MAIN Section (STR-D309/D359)	27
3-11.	Schematic Diagram	
	• MAIN Section (STR-A37)	32
3-12.	Printed Wiring Board	
	• MAIN Section (STR-A37)	37
3-13.	Semiconductor Lead Layouts	41
3-14.	IC Block Diagrams	42
SECTION 4. EXPLODED VIEWS		
4-1.	Chassis Section	44
4-2.	Cabinet Section	45
SECTION 5. ELECTRICAL PARTS LIST		
47		

SECTION 1 GENERAL

LOCATION OF CONTROLS

(STR-D309/D359)

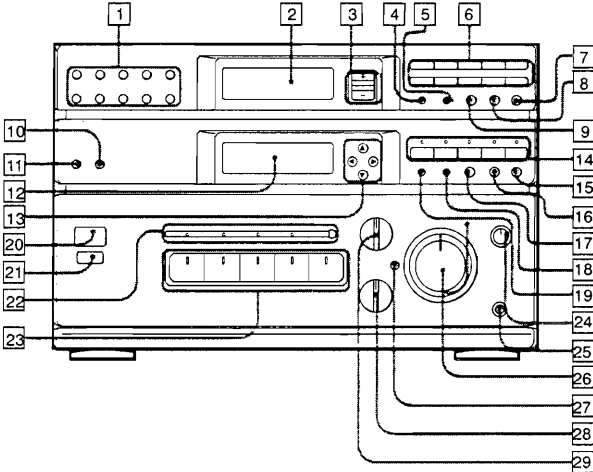

Tuner

- 1 Buttons for setting the clock and timer
- 2 Display window
- 3 DUAL MODE TUNING + / - buttons
- 4 MEMORY button
- 5 CHARACTER button
- 6 Numeric buttons
- 7 SHIFT button
- 8 BAND SELECT button
- 9 ST/MUTE button

Graphic Equalizer

- 10 REVERSE button
- 11 FLAT button
- 12 Display window
- 13 CURSOR CONTROL buttons
- 14 Preset/numeric buttons and indicators
- 15 DISPLAY button
- 16 PERSONAL FILE button and indicator
- 17 MEMORY button and indicator
- 18 EQ REC (equalizer recording) button and indicator
- 19 EFFECT button and indicator

Amplifier

- 20 SYSTEM POWER button
- 21 Remote control sensor
- 22 SURROUND button and indicator
- 23 Function selectors and indicators (VIDEO/TAPE/CD/TUNER/PHONO)
- 24 BALANCE control
- 25 HEADPHONES jack
- 26 VOLUME control and indicator
- 27 DBS ON/OFF (Dynamic Bass System) button and indicator
- 28 DBS FREQUENCY control
- 29 DBS LEVEL control

(STR-A37)

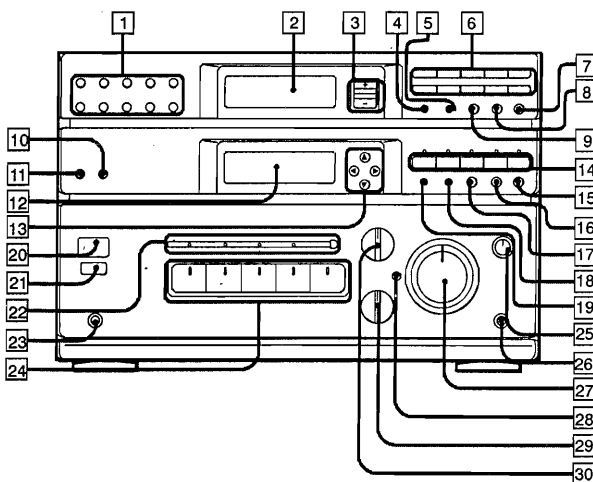

Tuner

- 1 Buttons for setting the clock and timer
- 2 Display window
- 3 DUAL MODE TUNING + / - buttons
- 4 MEMORY button
- 5 CHARACTER button
- 6 Numeric buttons
- 7 SHIFT button
- 8 BAND SELECT button
- 9 ST/MUTE button

Graphic Equalizer

- 10 REVERSE button
- 11 FLAT button
- 12 Display window
- 13 CURSOR CONTROL buttons
- 14 Preset/numeric buttons and indicators
- 15 DISPLAY button
- 16 PERSONAL FILE button and indicator
- 17 MEMORY button and indicator
- 18 EQ REC (equalizer recording) button and indicator
- 19 EFFECT button and indicator

Amplifier

- 20 SYSTEM POWER button
- 21 Remote control sensor
- 22 SURROUND button and indicator
- 23 MICROPHONE jacks
- 24 Function selectors and indicators (VIDEO/TAPE/CD/TUNER/PHONO)
- 25 BALANCE control
- 26 HEADPHONES jack
- 27 VOLUME control and indicator
- 28 DBS ON/OFF (Dynamic Bass System) button and indicator
- 29 DBS FREQUENCY control
- 30 DBS LEVEL control

SECTION 2 ADJUSTMENTS

Note: As a front-end (FE301) is difficult to repair if faulty, replace it with new one.

FM SECTION

Setting:

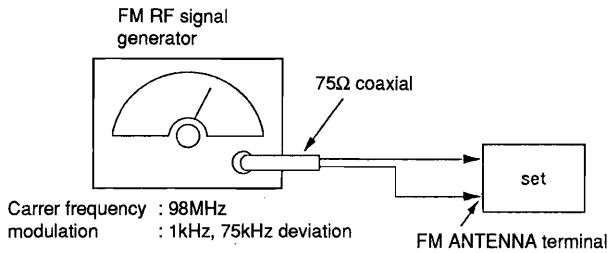

• TUNER OUT CHECK POINT

SPEAKER out receive 98MHz (EXCEPT EE), 70MHz (EE) 60dB μ (1mV) and set the Speaker out to 10dBs by VOLUME.

Speaker load: 6 Ω both CH

FM NULL Adjustment

Procedure:

1. Supply a 60dB μ (1mV) 98MHz (EXCEPT EE), 70MHz (EE) signal from the ANTENNA terminal.
2. Tune the set to 98MHz. (EXCEPT EE), 70MHz (EE)
3. Adjust T301 for 0V reading on the measurement point.

FM Tuned Level Adjustment

Band: FM

ST/MUTE SW: OFF

Procedure:

1. Supply a 20 \pm 4dB μ (EE), 25 \pm 4dB μ (EXCEPT EE) 98MHz (EXCEPT EE), 70MHz (EE) signal from the ANTENNA terminal.
2. Tune the set to 98MHz. (EXCEPT EE), 70MHz (EE)
3. Adjust RV302 so that the Voltage of IC301 ② pin is set to low.

Adjustment Location: ST MAIN BOARD

- Repeat the procedures in each adjustment several times, and the frequency coverage and tracking adjustments should be finally done by trimmer capacitors.

AM SECTION

Setting:

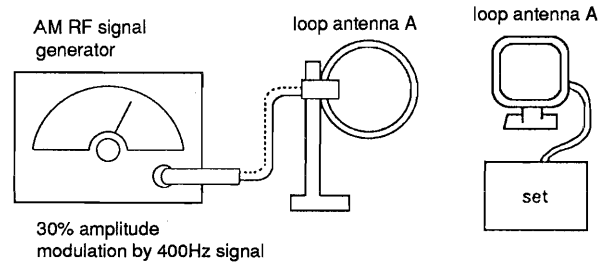

AM Tuned Level Adjustment

Band: AM

Procedure:

1. Set loop antenna input level to 94dB μ /m, 1050kHz and no signal tuned light should not on.
2. Tune the set to 1050kHz
3. Adjust RV301 so that the Voltage of IC301 ② pin is set to low.

Adjustment Location: tuner board

[ST MAIN BOARD] (component side)

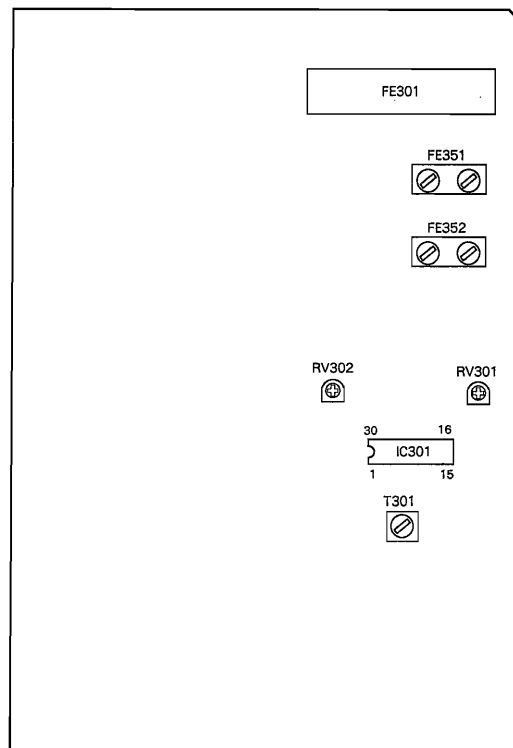

SECTION 3 DIAGRAMS

3-1. CIRCUIT BOARDS LOCATION

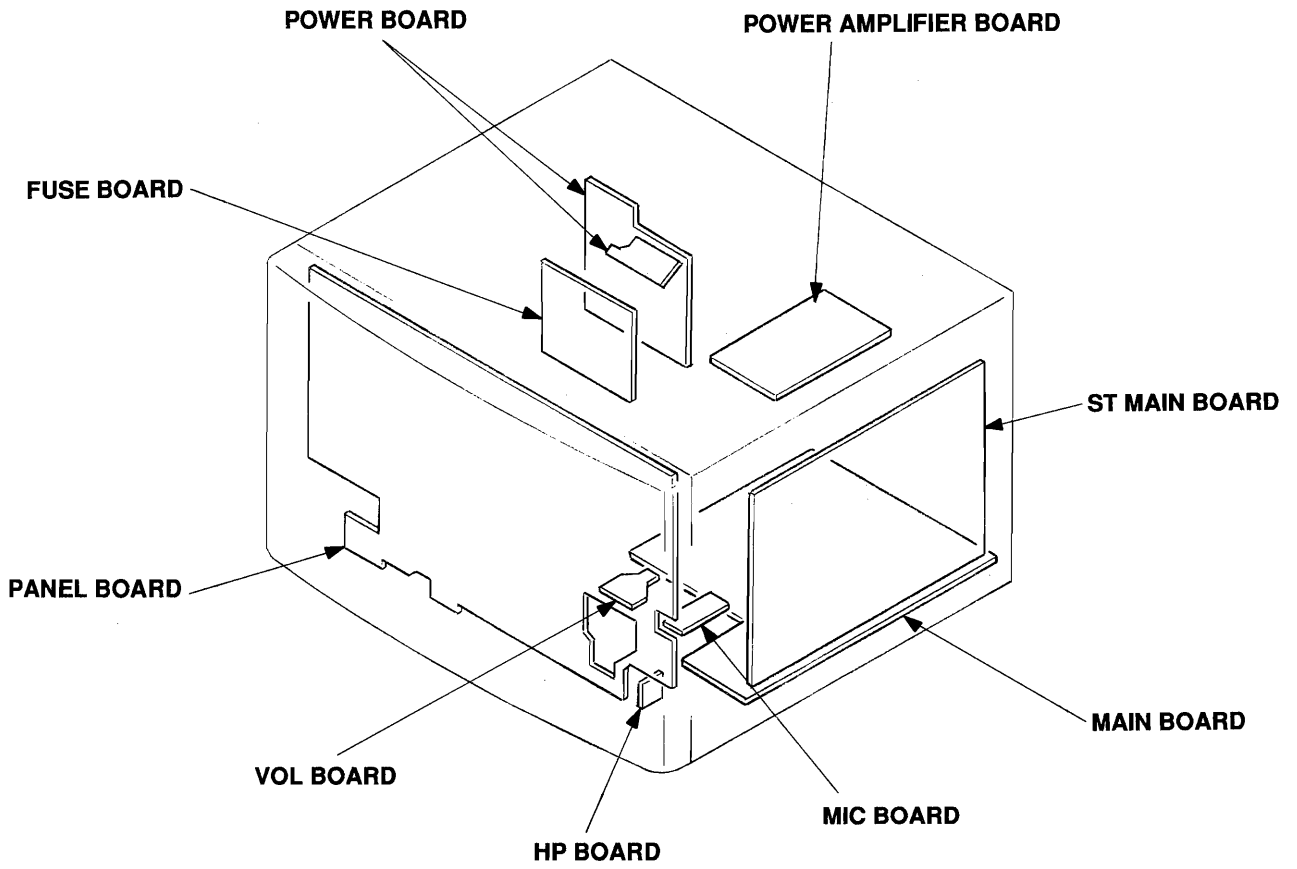

3-2. BLOCK DIAGRAM

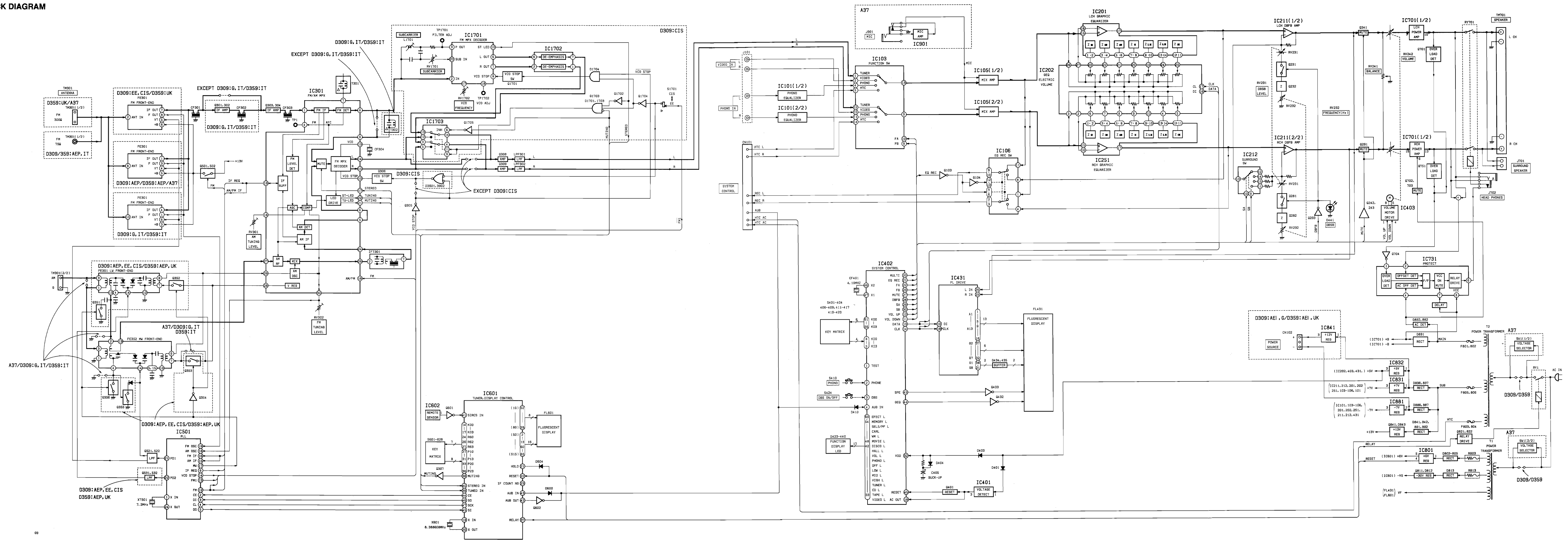

3-3. SCHEMATIC DIAGRAM
 • TUNER SECTION (STR-D309 : AEP, EE, CIS) (STR-D359 : AEP, UK)
 • See page 41, 42 and 43 for Semiconductor Lead Layouts and IC Block Diagrams.

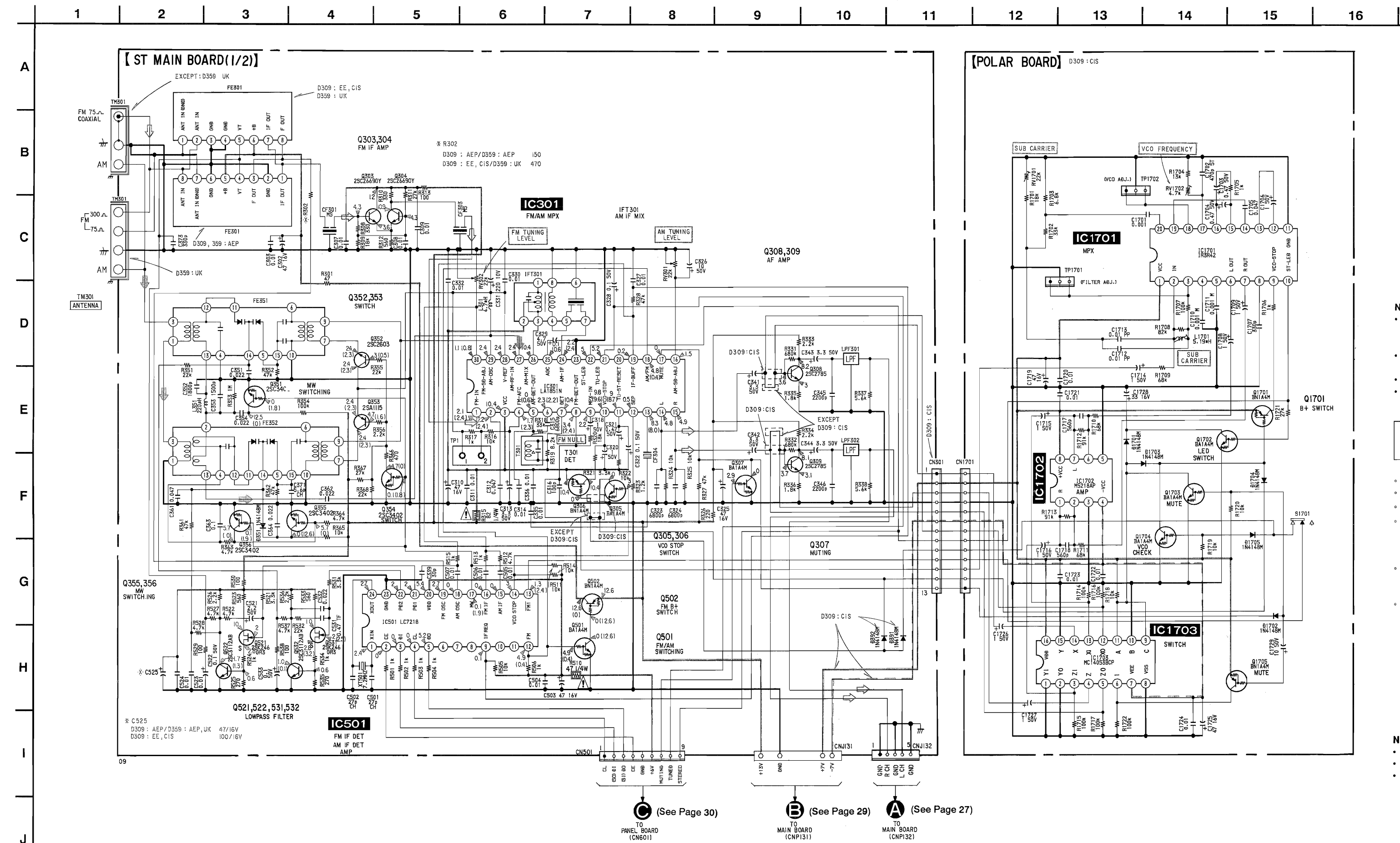

3-4. PRINTED WIRING BOARD
 • TUNER SECTION (STR-D309 : AEP, EE, CIS) (STR-D359 : AEP, UK)
 • See page 6 for Circuit Boards Location.

SEMICONDUCTOR LOCATION

Ref. No.	Location
D351	D-3
D391	I-4
D392	H-4
IC201	C-7
IC202	E-7
IC251	F-7
IC301	F-3
IC501	D-5
Q303	D-4
Q304	D-4
Q305	H-4
Q306	H-4
Q307	G-5
Q308	H-5
Q309	H-5
Q351	C-3
Q352	C-4
Q353	D-4
Q354	E-3
Q355	D-2
Q356	D-3
Q501	E-2
Q502	E-3
Q521	B-6
Q522	A-6
Q531	C-6
Q532	B-6

Note:

- All capacitors are in μF unless otherwise noted. pF , μF , mF or less are not indicated except for electrolytics and tantalums.
- All resistors are in Ω and $1/4\text{W}$ or less unless otherwise specified.
- \square : nonflammable resistor.
- Δ : internal component.

Note: The components identified by mark Δ or dotted line with mark Δ are critical for safety. Replace only with part number specified.

- : B+ Line
- : B- Line
- : adjustment for repair.
- Volts are dc with respect to ground under no-signal (detuned) conditions.
- no mark: FM
- (): AM
- Volts are taken with a VOM (Input Impedance 10 $\text{M}\Omega$). Voltage variations may be noted due to normal production tolerances.
- Signal path.
- \square : FM
- \square : AM

EE : East European

Note:

- \square : indicates side identified with part number.
- Δ : internal component.
- \circ : parts extracted from the components side.
- EE : East European

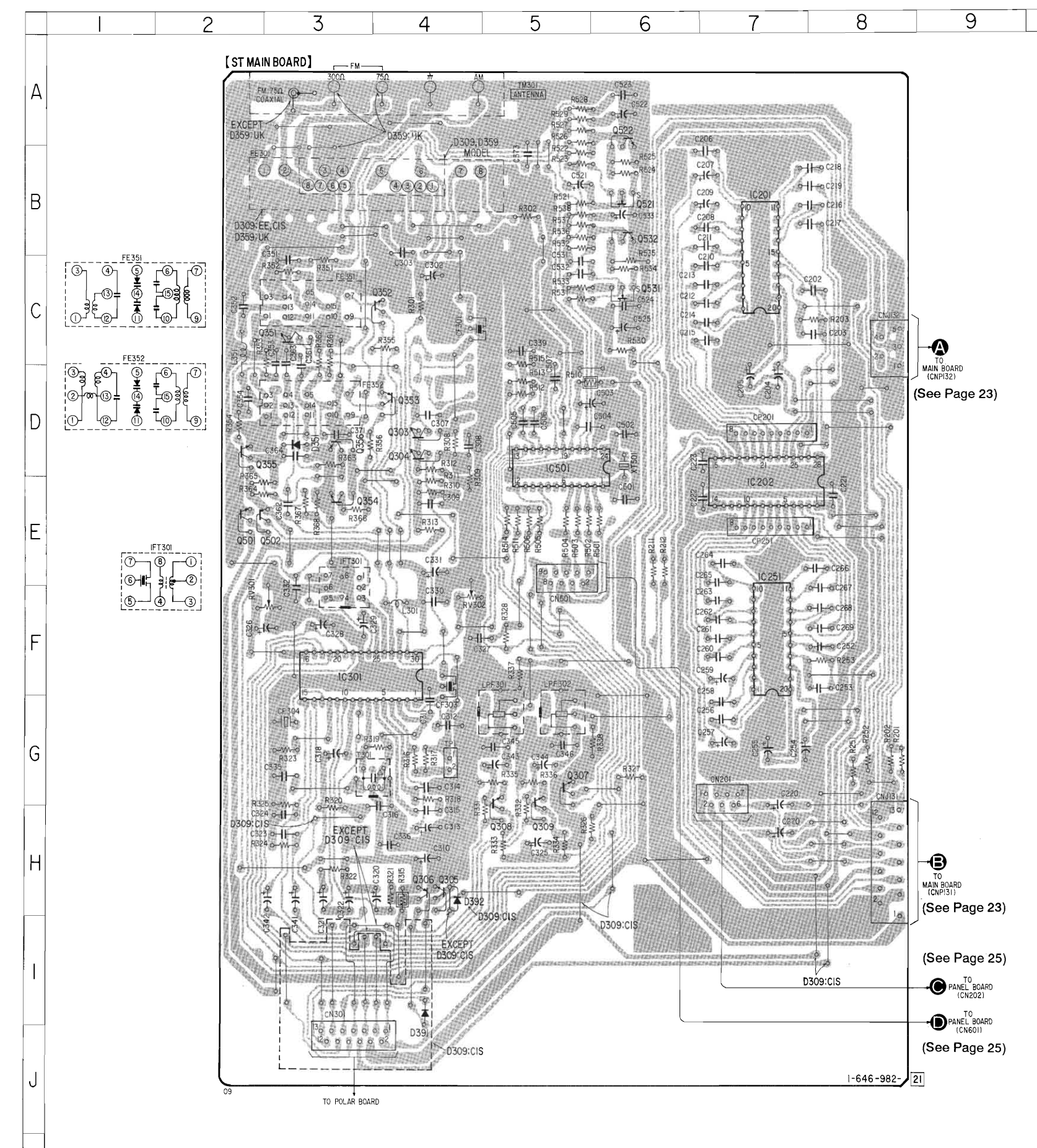

(See Page 23)

(See Page 23)

(See Page 25)

(See Page 25)

3-5. SCHEMATIC DIAGRAM
 • TUNER SECTION (STR-D309 : G, IT) (STR-D359 : IT)
 • See page 41, 42 and 43 for Semiconductor Lead Layouts and IC Block Diagrams.

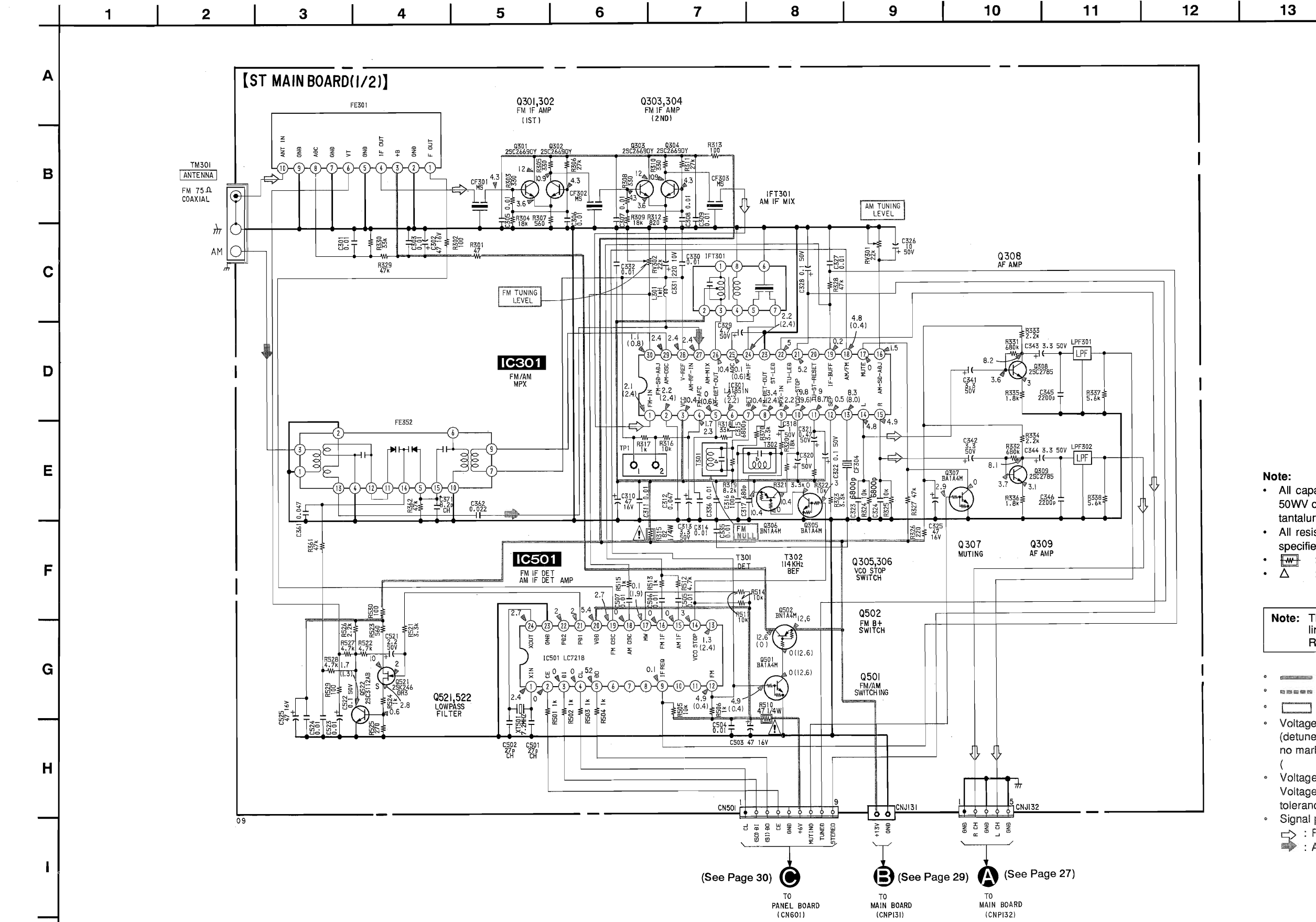

3-6. PRINTED WIRING BOARD
 • TUNER SECTION (STR-D309 : G, IT) (STR-D359 : IT)
 • See page 6 for Circuit Boards Location.

SEMICONDUCTOR LOCATION

Ref. No.	Location
IC201	C-7
IC202	E-7
IC251	F-7
IC301	F-3
IC501	D-5
Q303	D-4
Q304	D-4
Q305	H-4
Q306	H-4
Q307	G-5
Q308	H-5
Q309	H-5
Q501	E-2
Q502	E-3
Q521	B-6
Q522	A-6

Note:
 • All capacitors are in μF unless otherwise noted. pF : μF 50WV or less are not indicated except for electrolytics and tantalums.
 • All resistors are in Ω and 1/4W or less unless otherwise specified.
 • NF : nonflammable resistor.
 • Δ : internal component.

Note: The components identified by mark Δ or dotted line with mark Δ are critical for safety. Replace only with part number specified.

- : B+ Line
- - - : B- Line
- : adjustment for repair.
- Voltagages are dc with respect to ground under no-signal (detuned) conditions.
 no mark: FM
 (): AM
- Voltagages are taken with a VOM (Input Impedance 10 M Ω). Voltage variations may be noted due to normal production tolerances.
- Signal path.
- : FM
- ⇨ : AM

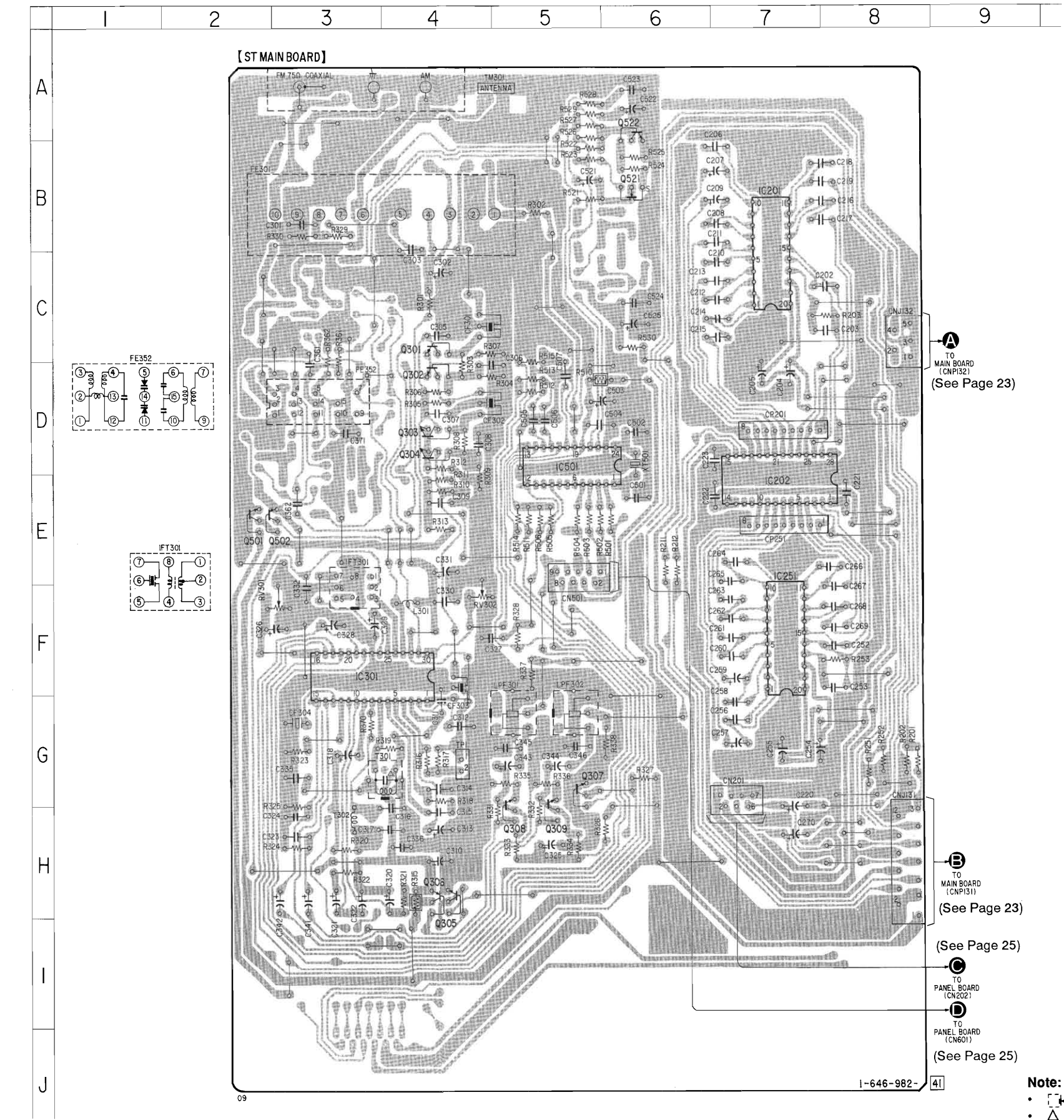

Note:
 • Δ : indicates side identified with part number.
 • Δ : internal component.
 • ○: parts extracted from the components side.

3-7. SCHEMATIC DIAGRAM
 • TUNER SECTION (STR-A37)
 • See page 41, 42 and 43 for Semiconductor Lead Layouts and IC Block Diagrams.

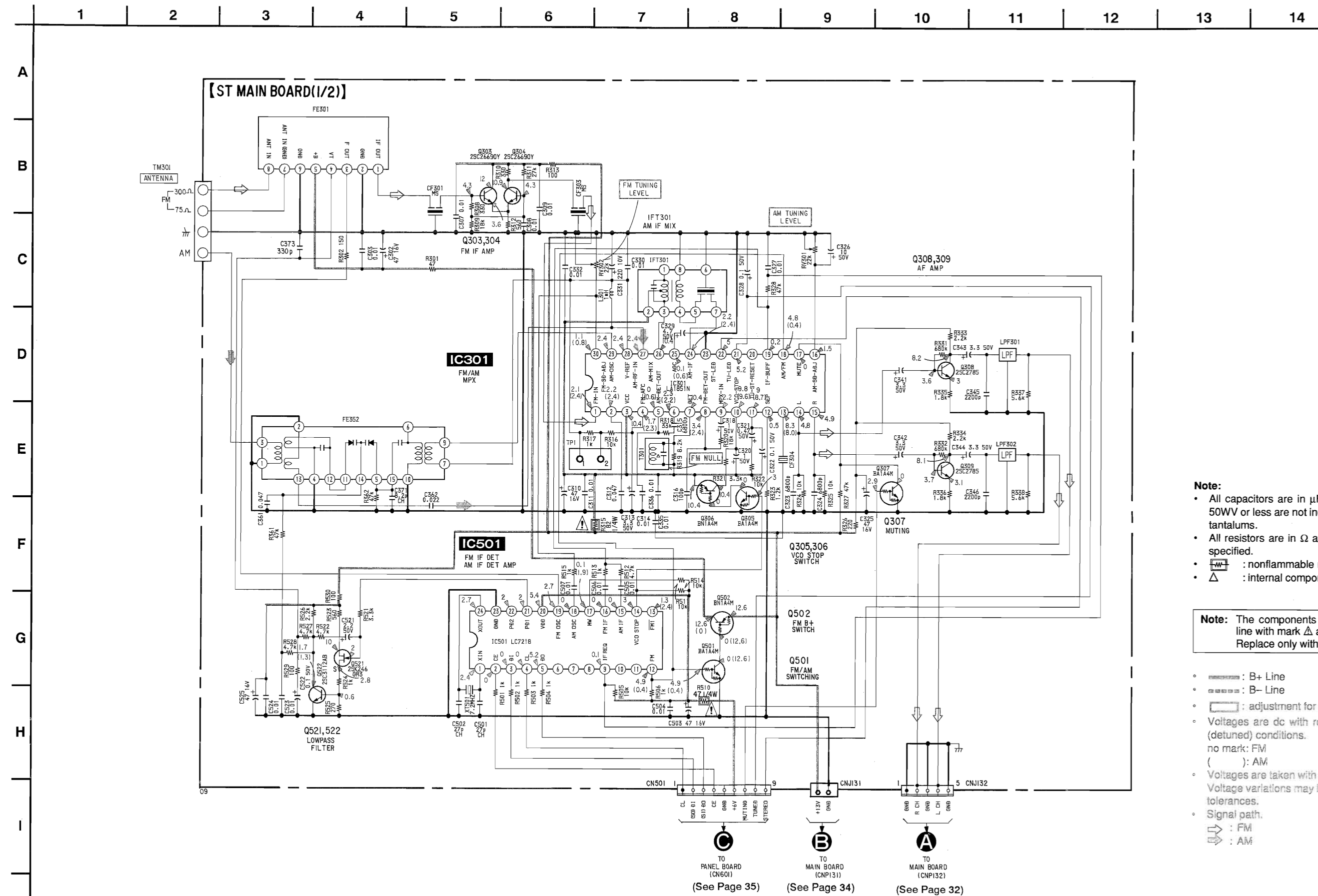

3-8. PRINTED WIRING BOARD
 • TUNER SECTION (STR-A37)
 • See page 6 for Circuit Boards Location.

SEMICONDUCTOR LOCATION

Ref. No.	Location
IC201	C-7
IC202	E-7
IC251	F-3
IC301	F-3
IC501	D-5
Q303	D-4
Q304	D-4
Q305	H-4
Q306	H-4
Q307	G-5
Q308	H-5
Q309	H-5
Q501	E-2
Q502	E-3
Q521	B-6
Q522	A-6

- Note:**
- All capacitors are in μF unless otherwise noted. pF ; μF 50WV or less are not indicated except for electrolytics and tantalums.
 - All resistors are in Ω and 1/4W or less unless otherwise specified.
 - NF : nonflammable resistor.
 - Δ : internal component.

Note: The components identified by mark Δ or dotted line with mark Δ are critical for safety. Replace only with part number specified.

- --- : B+ Line
- --- : B- Line
- --- : adjustment for repair.
- Voltages are dc with respect to ground under no-signal (detuned) conditions.
no mark: FM
(): AM
- Voltages are taken with a VOM (input Impedance 10 M Ω).
Voltage variations may be noted due to normal production tolerances.
- Signal path.
- --- : FM
- --- : AM

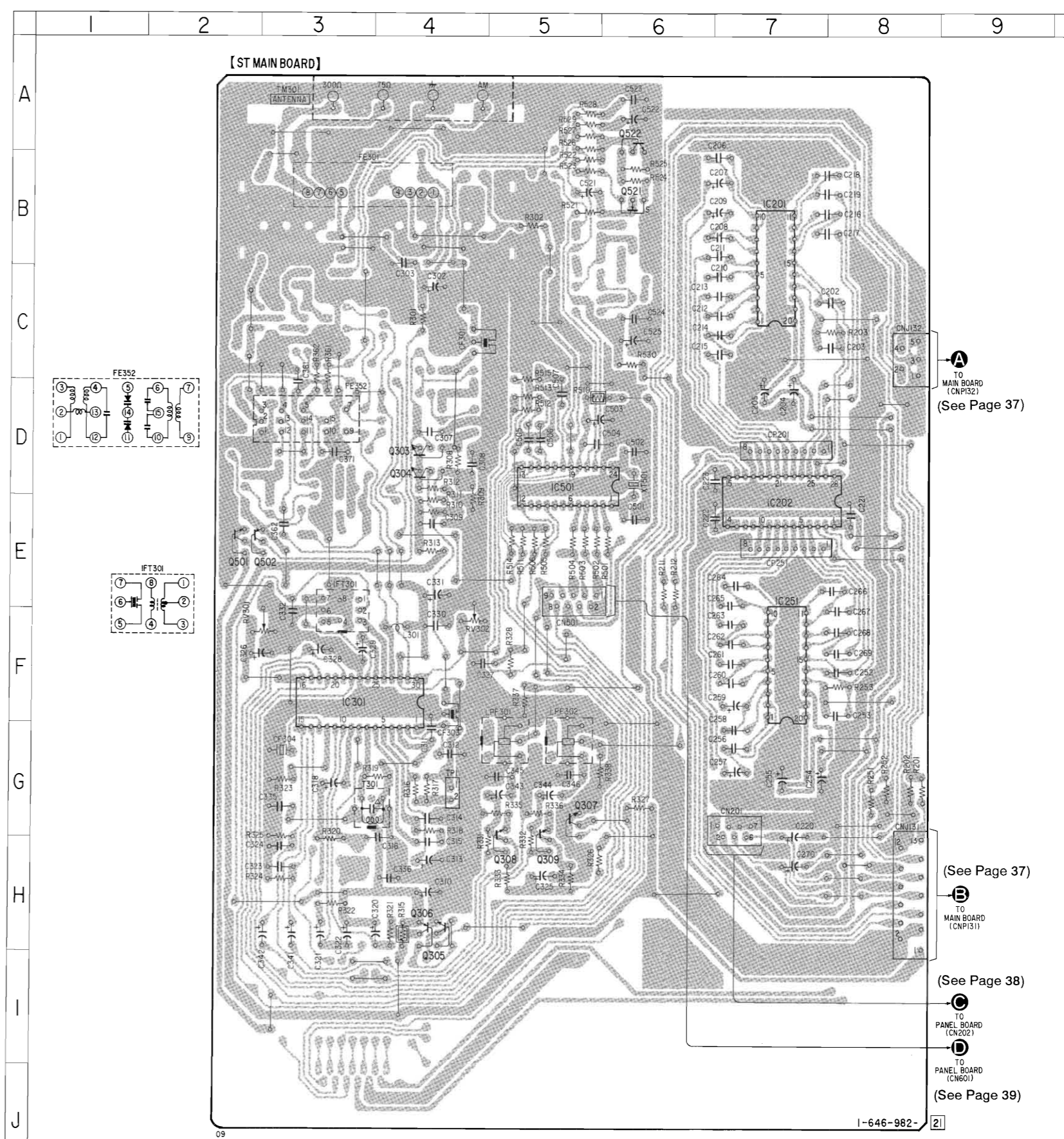

- Note:**
- --- : indicates side identified with part number.
 - Δ : internal component.
 - --- : parts extracted from the components side.

3-10. SCHEMATIC DIAGRAM
• MAIN SECTION (STR-D309/D359)
• See page 41, 42 and 43 for Semiconductor Lead Layouts and IC Block Diagrams.

REVISED

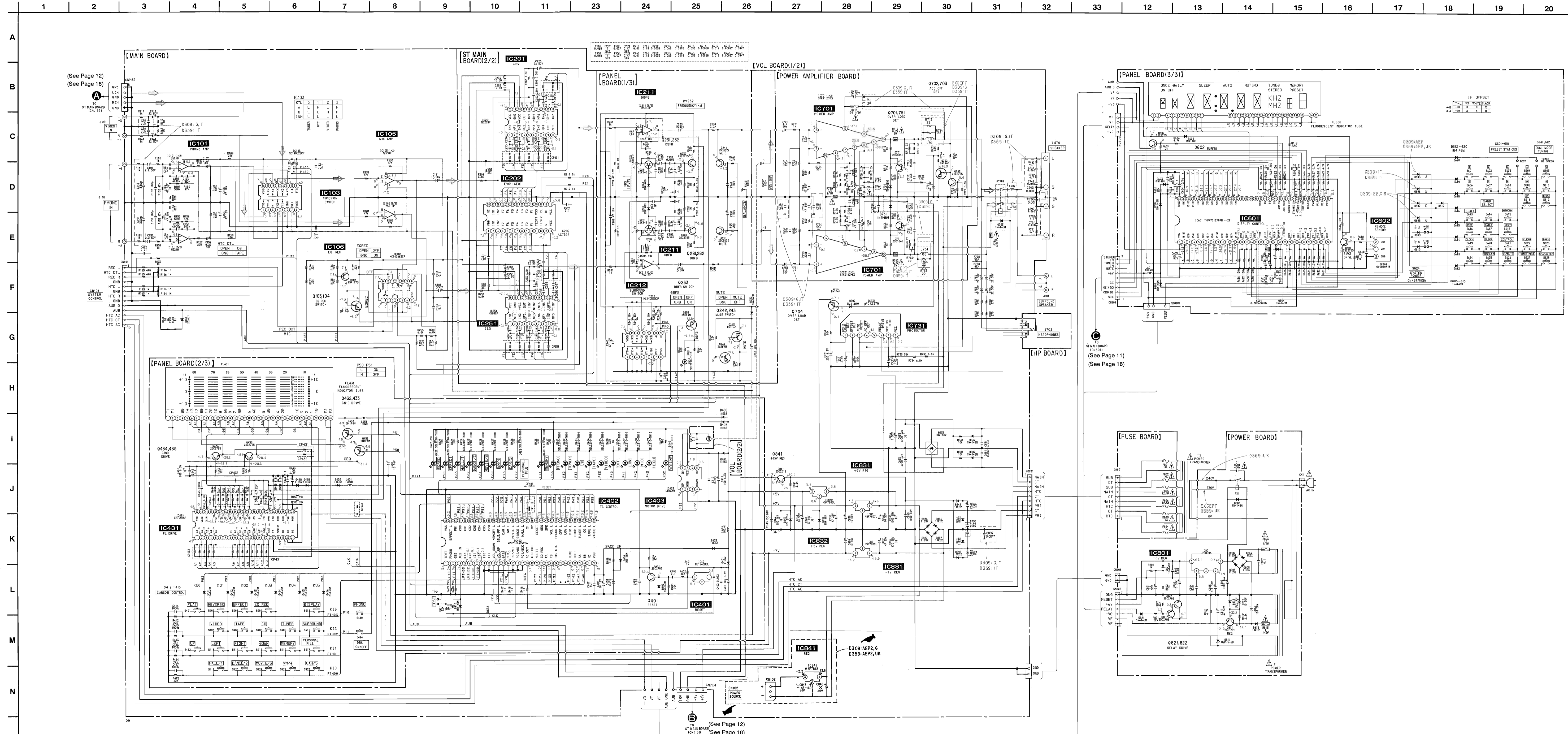

Note:
• All capacitors are in μF unless otherwise noted. pF μF 50WV or less are not indicated except for electrolytics and tantalums.
• All resistors are in Ω and 1/4W or less unless otherwise specified.
• \square : nonflammable resistor.
• \square : fusible resistor.
• \square : internal component.

Note: The components identified by mark Δ or dotted line with mark Δ are critical for safety. Replace only with part number specified.

• — : B+ Line
• - - - - : B- Line
• Voltages are dc with respect to ground under no-signal (detuned) conditions.
• Voltages are taken with a VOM (input impedance 10 M Ω). Voltage variations may be noted due to normal production tolerances.
• Signal path.
• \square : FM

G : Germany
IT : Italian
EE : East European

SEMICONDUCTOR LOCATION

Ref. No.	Location	Ref. No.	Location
D231	H-17	D806	I-28
D232	J-17	D811	H-27
D281	H-18	D812	J-27
D401	E-24	D813	K-27
D402	E-25	D821	H-27
D403	F-24	D831	E-7
D404	E-24	D832	F-8
D405	F-17	D836	G-6
D406	F-19	D837	F-6
D407	H-21	D838	G-5
D410	E-25	D841	G-6
D411	G-19	D842	G-6
D412	I-22	D843	I-3
D413	I-22	D882	F-8
D414	I-22	D886	F-6
D415	I-23	D887	F-6
D416	G-19		
D418	G-21	IC101	C-2
D419	G-20	IC103	E-3
D420	G-19	IC105	G-3
D422	F-15	IC106	H-3
D423	F-16	IC211	G-16
D424	E-16	IC212	J-19
D425	E-15	IC401	E-25
D426	E-15	IC402	G-23
D427	E-14	IC403	F-17
D428	E-13	IC431	E-21
D429	F-14	IC601	C-20
D430	F-15	IC602	H-26
D431	H-19	IC701	H-11
D432	H-20	IC731	D-8
D433	H-21	IC801	I-28
D434	H-22	IC831	A-4
D435	H-23	IC832	G-4
D436	G-23	IC881	E-4
D437	G-22	IC901	D-11
D438	G-21		
D439	G-20	Q103	H-3
D440	G-15	Q104	H-3
D441	H-17	Q231	H-18
D451	A-5	Q232	I-16
D600	D-24	Q233	J-16
D601	D-24	Q241	H-13
D602	D-23	Q242	I-14
D603	C-22	Q243	I-14
D604	D-20	Q281	H-18
D608	D-19	Q282	I-18
D609	D-18	Q291	H-14
D610	D-18	Q401	E-25
D611	D-18	Q432	E-22
D612	C-17	Q433	E-22
D613	C-24	Q434	E-20
D614	C-24	Q435	E-19
D615	D-17	Q601	E-26
D616	D-18	Q602	D-25
D617	D-18	Q701	I-9
D619	C-16	Q702	I-12
D620	B-15	Q703	J-12
D701	I-10	Q704	D-7
D702	D-7	Q751	I-12
D703	C-8	Q811	I-27
D751	I-12	Q821	H-28
D801	H-27	Q822	H-28
D802	K-27	Q841	I-4
D803	K-27		
D804	J-27		
D805	J-27		

3-12. PRINTED WIRING BOARD
 • MAIN SECTION (STR-A37)
 • See page 6 for Circuit Boards Location.

Note:
 • [Symbol] : indicates side identified with part number.
 • [Symbol] : internal component.
 • [Symbol] : parts extracted from the components side.

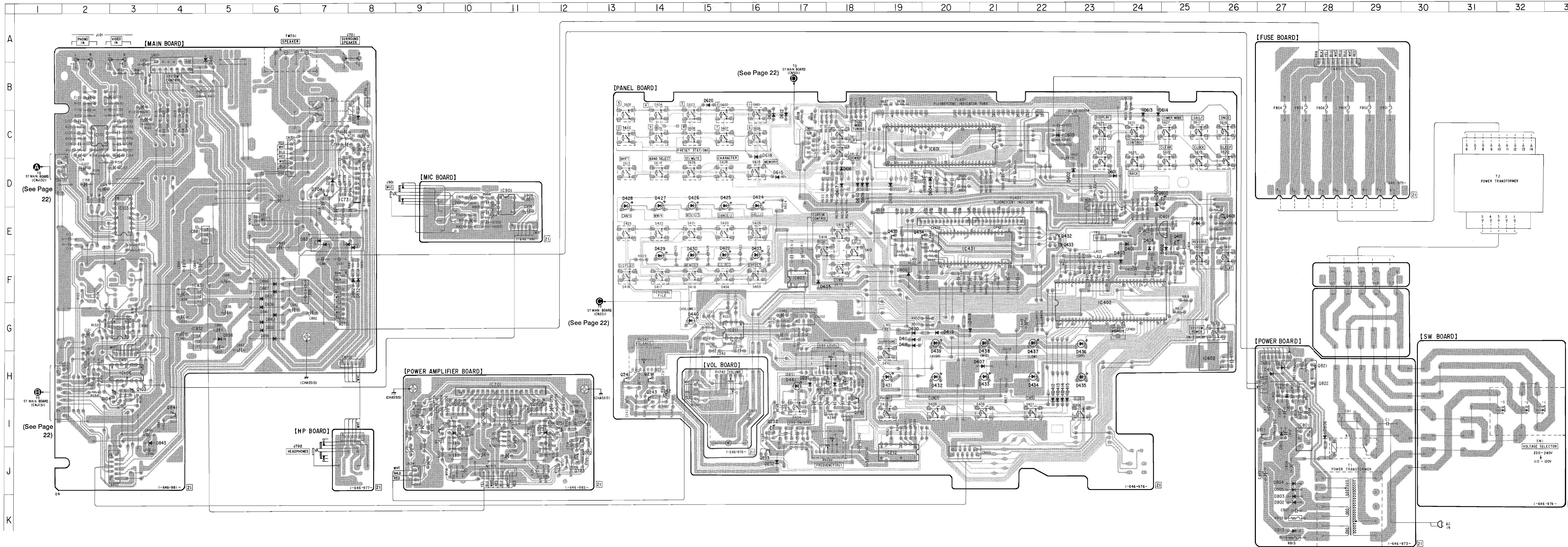

3-13. SEMICONDUCTOR LEAD LAYOUTS

AN6291
M5F78M05L
M5F78M07L

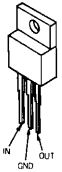

LC7522
LC7522K

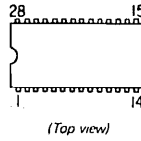

STK-4152MK2K
STK-4172MK2K

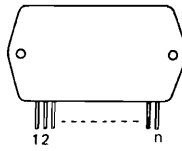

2SC1841-PAFAEA
2SC3112-B



HZS6A1L
UZL-33L
11ES2

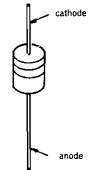

GP1U50XB

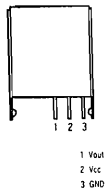

L78MR06

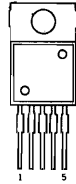

TMP47C1270AN-H211
uPD75104CW-286

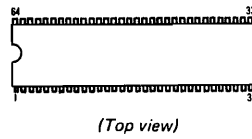

2SC2603-EF
2SC2669-0Y
2SC3622A-LK
DTA114ES
DTC114ES
DTC124ES



SEL2210S-CD
SEL3210S-CD

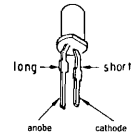

MC14052BCP
MC14053BCP

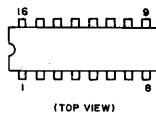

uPC1237HA



2SK246-GR3
2SK246-Y



IR3R42
M5289P

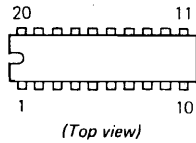

MC14066BCP

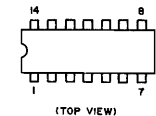

XR-1095

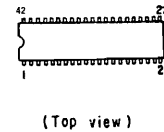

RBV-602-01

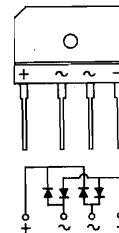

LA1851N

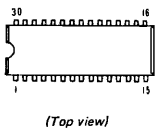

M5F79M07L

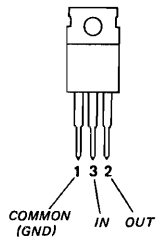

DTA124ES
2SA1175-HFE
2SC2785-HFE

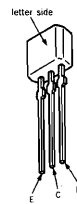

LB1639
M5218AP

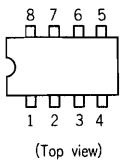

1N4148M
UZL-12M3
UZP-5.6B

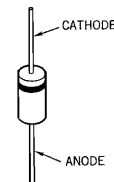

M51943BSL



2SB1094-LK
2SD2012

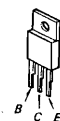

LC7218

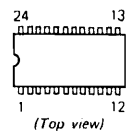

3-14. IC BLOCK DIAGRAMS

• IC201, 251 M5289P

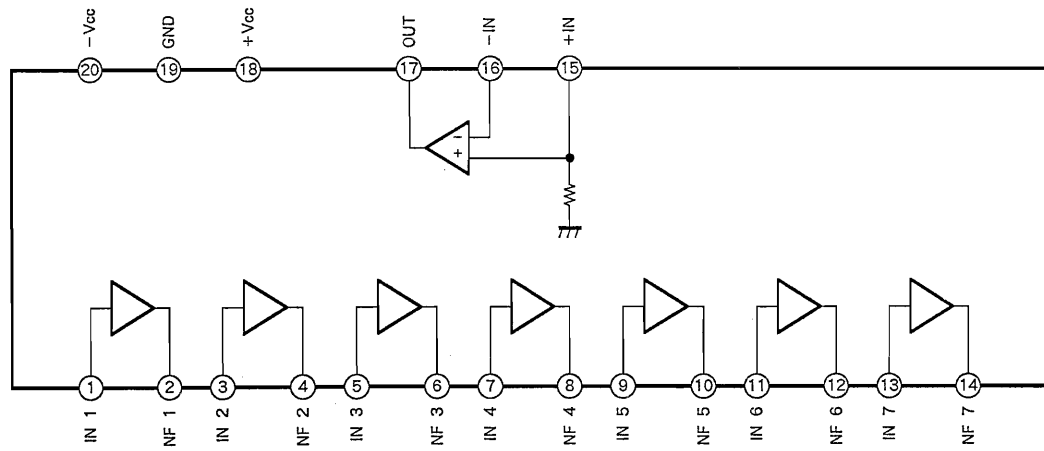

• IC403 LB1639

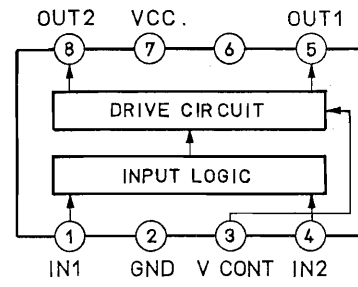

• IC801 L78MR06

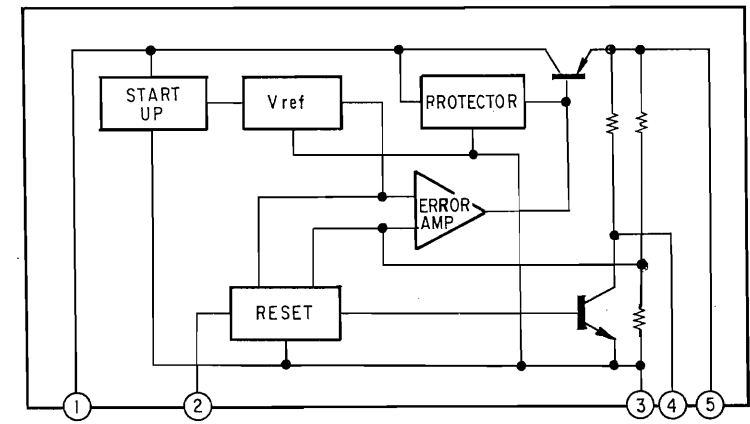

• IC202 LC7522

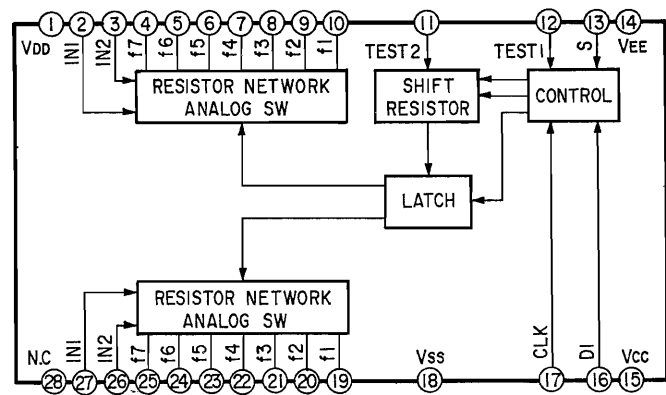

• IC501 LC7218

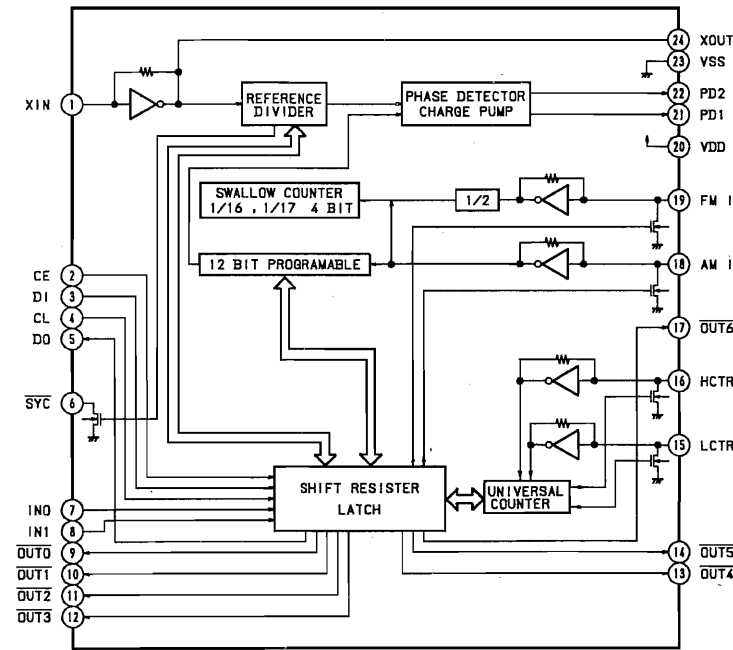

• IC1701 IR3R42

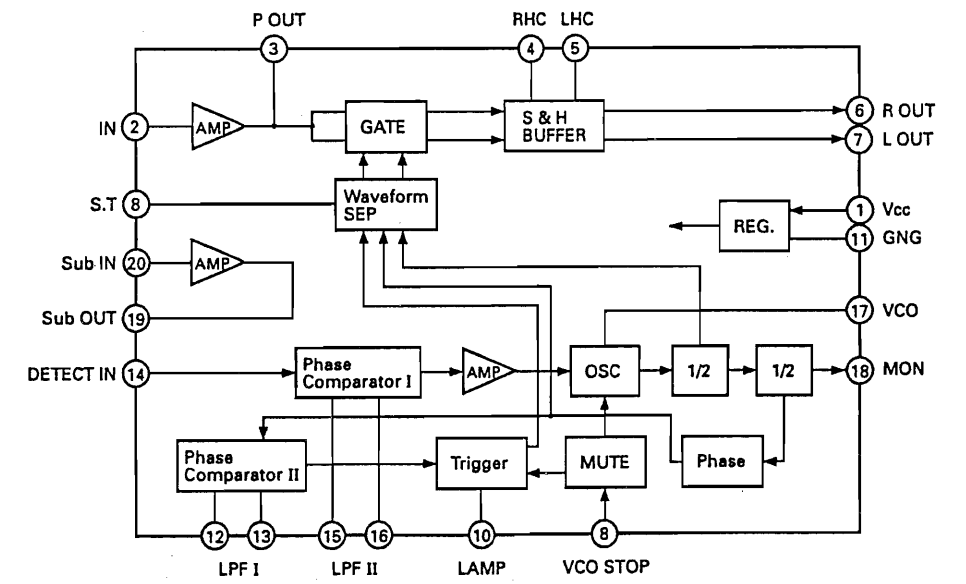

• IC301 LA1851N

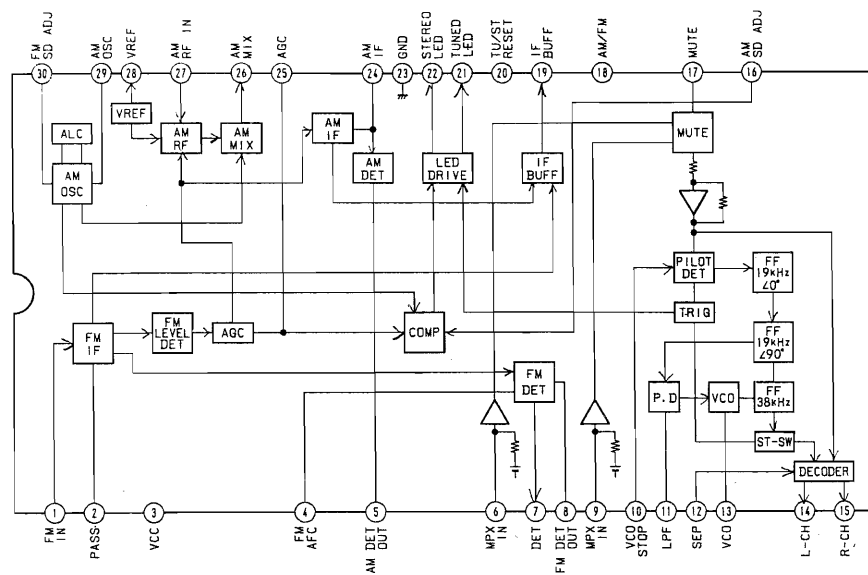

• IC731 uPC1237HA

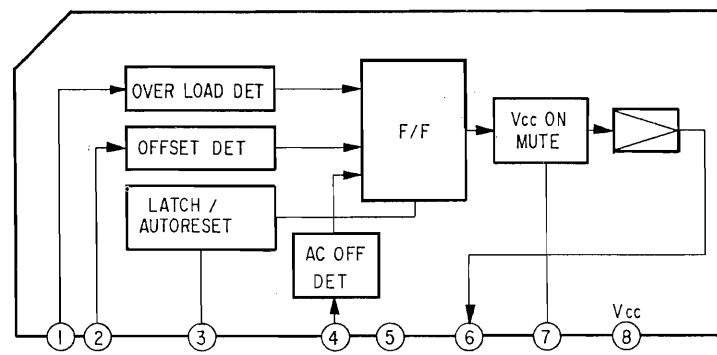

• IC1703 MC14053BCP

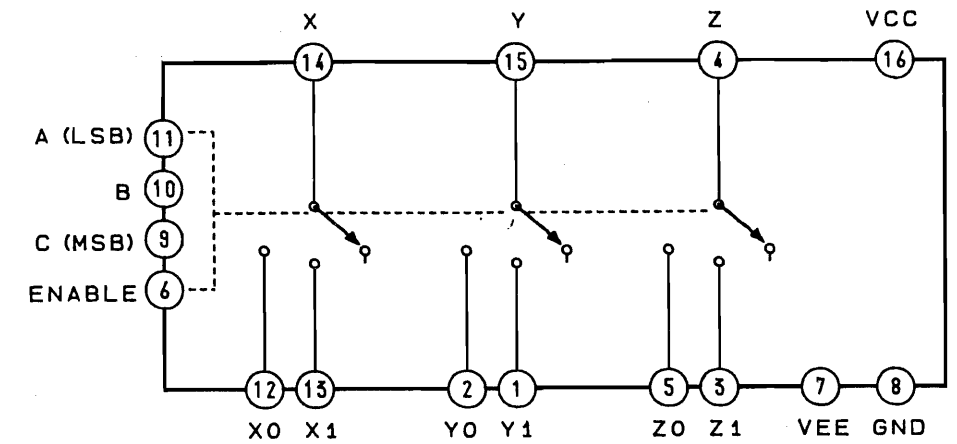

REVISED

4-2. CHASSIS SECTION

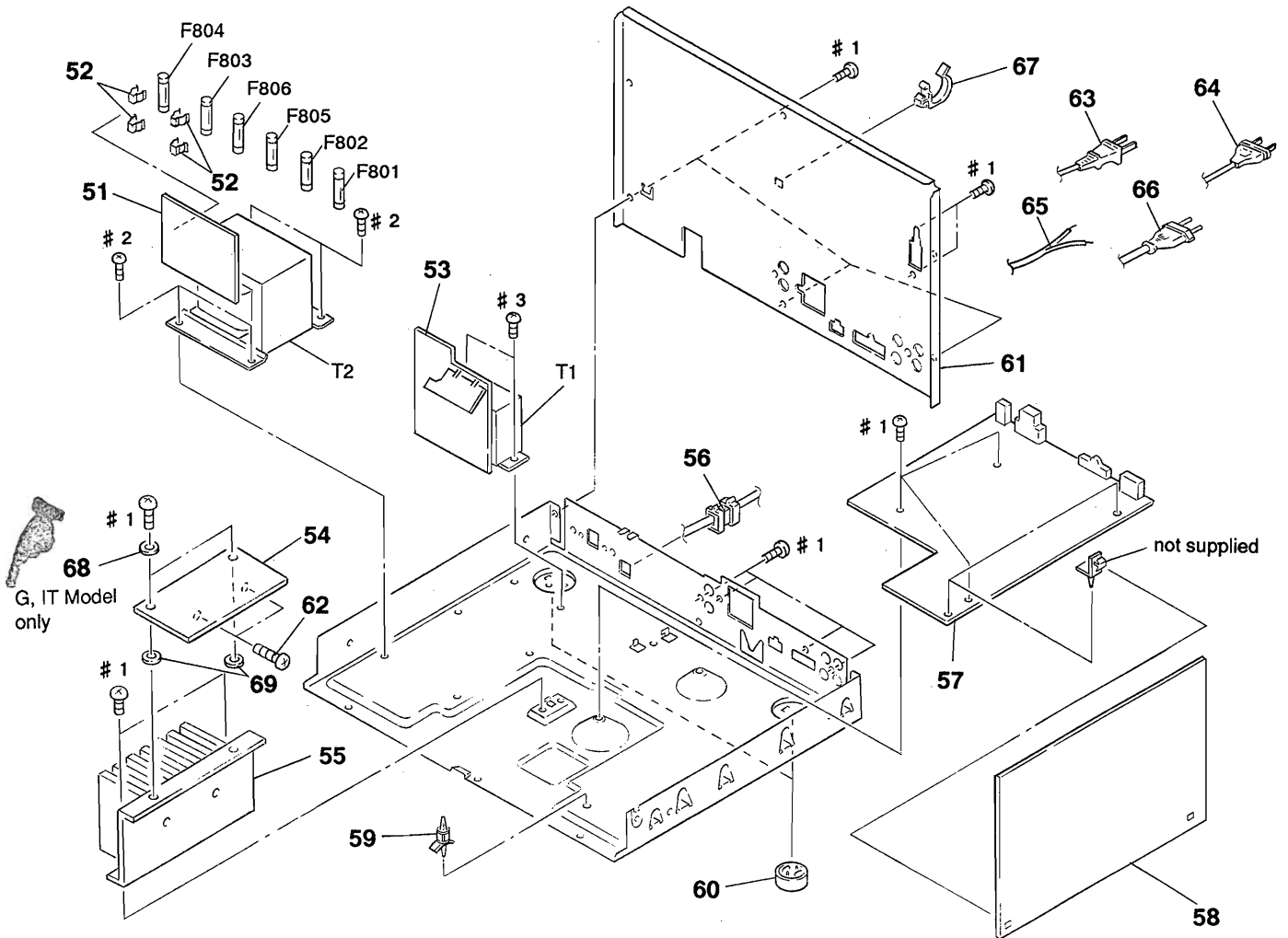

REVISED

Ref. No.	Part No.	Description	Remark	Ref. No.	Part No.	Description	Remark
* 51	1-646-972-11	FUSE BOARD (D309)		△F803	1-532-299-00	FUSE (5A)	
*	1-646-972-21	FUSE BOARD (D359)		△F804	1-532-299-00	FUSE (5A)	
52	1-533-217-31	HOLDER, FUSE (D309)		△F805	1-532-286-00	FUSE (2.5A)	
*	1-533-213-11	HOLDER, FUSE (A37/D359)		△F806	1-532-286-00	FUSE (2.5A)	
* 53	A-4356-906-A	POWER BOARD, COMPLETE (D309:AEP, G, IT, EE, CIS)		△T1	1-423-646-21	TRANSFORMER, POWER (D359)	
*	A-4356-987-A	POWER BOARD, COMPLETE (D359:AEP, IT)		△	1-423-646-31	TRANSFORMER, POWER (D309)	
*	A-4356-993-A	POWER BOARD, COMPLETE (D359:UK)		△	1-423-647-21	TRANSFORMER, POWER (A37)	
*	A-4360-002-A	POWER BOARD, COMPLETE (A37)		△T2	1-423-499-11	TRANSFORMER, POWER (D309)	
* 54	A-4356-905-A	POWER AMPLIFIER BOARD, COMPLETE (D309:AEP, EE, CIS)		△	1-423-499-21	TRANSFORMER, POWER (D359)	
*	A-4356-986-A	POWER AMPLIFIER BOARD, COMPLETE (D359:AEP)		△	1-423-500-21	TRANSFORMER, POWER (A37)	
*	A-4356-992-A	POWER AMPLIFIER BOARD, COMPLETE (D359:UK)					
*	A-4360-001-A	POWER AMPLIFIER BOARD, COMPLETE (A37)					
*	A-4360-132-A	POWER AMPLIFIER BOARD, COMPLETE (D309:G, IT)					
*	A-4360-506-A	POWER AMPLIFIER BOARD, COMPLETE (D359:IT)					
* 55	4-955-775-01	HEAT SINK (L3-E) (D309:AEP, G, IT, EE, CIS)					
* 56	3-703-244-00	BUSHING (2104), CORD (A37:AUS, D309, D359)					
*	3-703-571-11	BUSHING (S) (4516), CORD (A37:E, PX)					
* 57	A-4356-904-A	MAIN BOARD, COMPLETE (D309:AEP)					
*	A-4356-985-A	MAIN BOARD, COMPLETE (D359:AEP)					
*	A-4356-991-A	MAIN BOARD, COMPLETE (D359:UK)					
*	A-4360-000-A	MAIN BOARD, COMPLETE (A37)					
*	A-4360-131-A	MAIN BOARD, COMPLETE (D309:G)					
*	A-4360-177-A	MAIN BOARD, COMPLETE (D309:AEP, EE, CIS)					
*	A-4360-185-A	MAIN BOARD, COMPLETE (D309:IT)					
*	A-4360-499-A	MAIN BOARD, COMPLETE (D359:AEP)					
*	A-4360-505-A	MAIN BOARD, COMPLETE (D359:IT)					
* 58	A-4356-901-A	ST MAIN BOARD, COMPLETE (D309:AEP)					
*	A-4356-982-A	ST MAIN BOARD, COMPLETE (D359:AEP)					
*	A-4356-989-A	ST MAIN BOARD, COMPLETE (D359:UK)					
*	A-4356-998-A	ST MAIN BOARD, COMPLETE (A37)					
*	A-4360-123-A	ST MAIN BOARD, COMPLETE (D309:G, IT)					
*	A-4360-503-A	ST MAIN BOARD, COMPLETE (D359:IT)					
*	A-4360-814-A	ST MAIN BOARD, COMPLETE (D309:EE)					
*	A-4360-817-A	ST MAIN BOARD, COMPLETE (D309:CIS)					
59	4-943-687-01	HOLDER, PC BOARD					
60	4-933-601-01	FOOT (A37, D359)					
	X-4941-228-1	FOOT ASSY (D309)					
* 61	4-955-769-11	PANEL, BACK (D309:AEP)					
*	4-955-769-21	PANEL, BACK (D309:CIS)					
*	4-955-769-31	PANEL, BACK (D309:IT)					
*	4-955-769-41	PANEL, BACK (D309:G)					
*	4-955-769-51	PANEL, BACK (D309:AEP)					
*	4-955-769-61	PANEL, BACK (D309:AEP)					
*	4-955-769-71	PANEL, BACK (D309:EE)					
*	4-955-828-11	PANEL, BACK (D359:AEP)					
*	4-955-828-21	PANEL, BACK (D359:UK)					
*	4-955-828-31	PANEL, BACK (D359:IT)					
*	4-955-828-51	PANEL, BACK (D359:AEP)					
*	4-955-828-61	PANEL, BACK (A37:E, PX)					
*	4-955-828-71	PANEL, BACK (A37:AUS)					
62	4-928-635-11	SCREW, +BV (2.6X16) TAPPING					
△63	1-575-653-11	CORD, POWER (A37:E, PX)					
△64	1-690-608-11	CORD, POWER (A37:AUS)					
△65	1-696-570-21	CORD, POWER (D359:UK)					
△66	1-575-651-11	CORD, POWER (D309:AEP, G, IT, EE, CIS/D359:AEP, IT)					
67	4-956-370-02	BAND, PLUG FIXED (A37:AUS)					
68	4-960-342-21	WASHER (HEAT SINK) (G, IT)					
69	4-960-342-31	WASHER (HEAT SINK)					
△F801	1-532-078-00	FUSE (1A)					
△F802	1-532-078-00	FUSE (1A)					

The components identified by mark △ or dotted line with mark △ are critical for safety. Replace only with part number specified.

REVISED

SECTION 5
ELECTRICAL PARTS LIST

FUSE HP MAIN

NOTE:

The components identified by mark Δ or dotted line with mark Δ are critical for safety. Replace only with part number specified.

When indicating parts by reference number, please include the board name.

- Due to standardization, replacements in the parts list may be different from the parts specified in the diagrams or the components used on the set.
• -XX, -X mean standardized parts, so they may have some difference from the original one.
• RESISTORS
All resistors are in ohms
METAL: Metal-film resistor
METAL OXIDE: Metal Oxide-film resistor
F : nonflammable
• Color Indication of Appearance Parts Example:
KNOB, BALANCE (WHITE) . . . (RED)
↑ ↑
Parts color Cabinet's color
• Items marked "*" are not stocked since they are seldom required for routine service. Some delay should be anticipated when ordering these items.

- SEMICONDUCTORS
In each case, u: μ, for example:
uA...: μ A..., uPA...: μ PA...,
uPB...: μ PB..., uPC...: μ PC...,
uPD...: μ PD...
• CAPACITORS
uF : μ F
• COILS
uH : μ H
• Hardware (# mark) list is given in the last of this parts list.
• G : Germany model
• IT : Italian model
• EE : East European model
• CIS : Common Independent States model
• AUS: Australian model
AEP1: AEP with out POWER SOURCE
AEP2: AEP with POWER SOURCE

Table with columns: Ref. No., Part No., Description, Remark, Ref. No., Part No., Description, Remark. Contains parts list for FUSE BOARD, HP BOARD, MAIN BOARD, and various capacitors.

REVISED

MAIN

Ref. No.	Part No.	Description	Remark	Ref. No.	Part No.	Description	Remark
C742	1-136-163-00	FILM 0.068uF 5% 50V (D309:G, IT/D359:IT)		* CN131	1-568-955-11	PIN, CONNECTOR 6P (A37)	
C743	1-162-294-31	CERAMIC 0.001uF 10% 50V (D309:G, IT/D359:IT)		* CN402	1-568-830-11	SOCKET, CONNECTOR 11P	
C784	1-124-916-11	ELECT 22uF 20% 63V		* CN701	1-564-510-11	PLUG, CONNECTOR 7P	
C785	1-124-916-11	ELECT 22uF 20% 63V		* CN702	1-568-954-11	PIN, CONNECTOR 5P	
C791	1-136-163-00	FILM 0.068uF 5% 50V (D309:G, IT/D359:IT)		CNP131	1-695-090-11	PIN, CONNECTOR (PC BOARD) 13P	
C792	1-136-163-00	FILM 0.068uF 5% 50V (D309:G, IT/D359:IT)		CNP132	1-750-180-11	PIN, CONNECTOR (PC BOARD) 5P	
C793	1-162-294-31	CERAMIC 0.001uF 10% 50V (D309:G, IT/D359:IT)		< DIODE >			
C831	1-136-161-00	FILM 0.047uF 5% 50V		D451	8-719-933-33	DIODE HZS6A1L	
C833	1-126-138-11	ELECT 4700uF 20% 50V (A37)		D702	8-719-987-63	DIODE 1N4148M	
C833	1-126-224-11	ELECT 4700uF 20% 42V (D309/D359)		D703	8-719-987-63	DIODE 1N4148M	
C834	1-124-903-11	ELECT 1uF 20% 50V		D831	8-719-302-38	DIODE RBV-602-01	
C835	1-102-394-11	CERAMIC 0.01uF 250V		D832	8-719-987-63	DIODE 1N4148M	
C836	1-124-557-11	ELECT 1000uF 20% 25V		D836	8-719-200-82	DIODE 11ES2	
C837	1-124-907-11	ELECT 10uF 20% 50V		D837	8-719-200-82	DIODE 11ES2	
C838	1-124-907-11	ELECT 10uF 20% 50V		D838	8-719-987-63	DIODE 1N4148M	
C839	1-124-477-11	ELECT 47uF 20% 25V		D841	8-719-200-82	DIODE 11ES2	
C840	1-124-477-11	ELECT 47uF 20% 25V (A37)		D842	8-719-200-82	DIODE 11ES2	
C840	1-124-126-00	ELECT 47uF 20% 10V (D309/D359)		D843	8-719-001-76	DIODE UZL-12M3	
C841	1-124-907-11	ELECT 10uF 20% 50V		D882	8-719-987-63	DIODE 1N4148M	
C842	1-124-122-11	ELECT 100uF 20% 50V		D886	8-719-200-82	DIODE 11ES2	
C843	1-126-105-11	ELECT 1000uF 20% 35V		D887	8-719-200-82	DIODE 11ES2	
C844	1-126-101-11	ELECT 100uF 20% 16V		D891	8-719-200-82	DIODE 11ES2	
C845	1-126-101-11	ELECT 100uF 20% 16V		D892	8-719-200-82	DIODE 11ES2	
C846	1-124-122-11	ELECT 100uF 20% 50V (D309:AEP2, G/D359:AEP2, UK)		< IC >			
C847	1-124-477-11	ELECT 47uF 20% 25V (D359:AEP2, UK)		IC101	8-759-634-51	IC M5218AP	
C847	1-124-910-11	ELECT 47uF 20% 50V (D309:AEP2, G)		IC103	8-759-000-48	IC MC14052BCP	
C881	1-136-161-00	FILM 0.047uF 5% 50V		IC105	8-759-634-51	IC M5218AP	
C883	1-126-138-11	ELECT 4700uF 20% 50V (A37)		IC106	8-759-000-49	IC MC14066BCP	
C883	1-126-224-11	ELECT 4700uF 20% 42V (D309/D359)		IC731	8-759-111-68	IC uPC1237HA	
C886	1-124-480-11	ELECT 470uF 20% 25V		IC831	8-759-605-00	IC M5F78M07L	
C887	1-124-477-11	ELECT 47uF 20% 25V		IC832	8-759-604-35	IC M5F78M05L	
C888	1-124-907-11	ELECT 10uF 20% 50V		IC841	8-759-604-39	IC AN6291 (D309:AEP2, G/D359:AEP2, UK)	
C892	1-124-122-11	ELECT 100uF 20% 50V		IC881	8-759-604-95	IC M5F79M07L	
C897	1-161-377-00	CERAMIC 0.0047uF 30% 25V (D309:G, IT/D359:IT)		< JACK >			
< CONNECTOR >				* J101	1-580-912-11	JACK, PIN 4P (PHONO/VIDEO IN) (D309)	
* CN101	1-565-291-11	SOCKET, CONNECTOR 13P (SYSTEM CONTROL)		* J101	1-580-912-21	JACK, PIN 4P (PHONO/VIDEO IN) (A37/D359)	
* CN102	1-566-210-11	PIN, CONNECTOR 3P (POWER SOURCE) (D309:AEP2, G/D359:AEP2, UK)		* J701	1-569-130-11	JACK, PIN 2P (SURROUND SPEAKER)	
< TRANSISTOR >				L702	1-420-872-00	COIL, AIR CORE (D309:G, IT/D359:IT)	
Q103	8-729-119-76	TRANSISTOR 2SA1175-HFE		L752	1-420-872-00	COIL, AIR CORE (D309:G, IT/D359:IT)	

REVISED

R733 1-249-436-11 CARBON 39K 5% 1/4W (EXCEPT D359:AEP1)
R733 1-249-437-11 CARBON 47K 5% 1/4W (D359:AEP1)

MAIN MIC

Ref. No.	Part No.	Description	Remark	Ref. No.	Part No.	Description	Remark
Q104	8-729-900-36	TRANSISTOR	DTC124ES	R204	1-249-421-11	CARBON 2.2K 5% 1/4W	
Q704	8-729-900-63	TRANSISTOR	DTA124ES	R205	1-249-427-11	CARBON 6.8K 5% 1/4W	
Q841	8-729-209-15	TRANSISTOR	2SD2012				
< RESISTOR >							
R101	1-249-417-11	CARBON	1K 5% 1/4W	R254	1-249-421-11	CARBON 2.2K 5% 1/4W	
R102	1-249-437-11	CARBON	47K 5% 1/4W	R255	1-249-427-11	CARBON 6.8K 5% 1/4W	
R104	1-249-416-11	CARBON	820 5% 1/4W	R431	1-249-393-11	CARBON 10 5% 1/4W	
R105	1-247-897-11	CARBON	560K 5% 1/4W	R432	1-249-417-11	CARBON 1K 5% 1/4W	
R106	1-249-437-11	CARBON	47K 5% 1/4W	R728	1-249-438-11	CARBON 56K 5% 1/4W	
R107	1-249-409-11	CARBON	220 5% 1/4W	R731	1-249-429-11	CARBON 10K 5% 1/4W	
R108	1-249-441-11	CARBON	100K 5% 1/4W	R732	1-249-441-11	CARBON 100K 5% 1/4W	
R109	1-249-409-11	CARBON	220 5% 1/4W	R733	1-249-436-11	CARBON 39K 5% 1/4W	
R111	1-249-417-11	CARBON	1K 5% 1/4W	R734	1-249-427-11	CARBON 6.8K 5% 1/4W	
R112	1-247-903-00	CARBON	1M 5% 1/4W	R735	1-249-427-11	CARBON 6.8K 5% 1/4W	
R113	1-249-417-11	CARBON	1K 5% 1/4W	Δ R736	1-215-891-11	METAL OXIDE 680 5% 2W F	
R114	1-247-903-00	CARBON	1M 5% 1/4W	R737	1-249-410-11	CARBON 270 5% 1/4W	
R115	1-249-413-11	CARBON	470 5% 1/4W	R738	1-249-410-11	CARBON 270 5% 1/4W	
R116	1-247-903-00	CARBON	1M 5% 1/4W				
R121	1-249-433-11	CARBON	22K 5% 1/4W	R741	1-249-389-11	CARBON 4.7 5% 1/4W	(D309:G, IT/D359:IT)
R122	1-249-433-11	CARBON	22K 5% 1/4W	R742	1-249-389-11	CARBON 4.7 5% 1/4W	(D309:G, IT/D359:IT)
R123	1-249-433-11	CARBON	22K 5% 1/4W				
R124	1-249-433-11	CARBON	22K 5% 1/4W	R778	1-249-437-11	CARBON 47K 5% 1/4W	
R131	1-249-437-11	CARBON	47K 5% 1/4W	R787	1-249-410-11	CARBON 270 5% 1/4W	
R132	1-249-437-11	CARBON	47K 5% 1/4W (A37)	R788	1-249-410-11	CARBON 270 5% 1/4W	
R133	1-249-437-11	CARBON	47K 5% 1/4W	R791	1-249-389-11	CARBON 4.7 5% 1/4W	(D309:G, IT/D359:IT)
R135	1-249-433-11	CARBON	22K 5% 1/4W	R792	1-249-389-11	CARBON 4.7 5% 1/4W	(D309:G, IT/D359:IT)
R136	1-249-433-11	CARBON	22K 5% 1/4W				
R137	1-249-433-11	CARBON	22K 5% 1/4W	R831	1-249-429-11	CARBON 10K 5% 1/4W	
R141	1-249-417-11	CARBON	1K 5% 1/4W	R841	1-249-421-11	CARBON 2.2K 5% 1/4W	
			(D309:G, IT/D359:IT)	R881	1-249-429-11	CARBON 10K 5% 1/4W	
				< RELAY >			
R151	1-249-417-11	CARBON	1K 5% 1/4W	RY701	1-515-533-11	RELAY	
R152	1-249-437-11	CARBON	47K 5% 1/4W				
R154	1-249-416-11	CARBON	820 5% 1/4W				
R155	1-247-897-11	CARBON	560K 5% 1/4W	< TERMINAL >			
R156	1-249-437-11	CARBON	47K 5% 1/4W	TM701	1-537-481-11	TERMINAL BOARD (SPEAKER)	(D309:G, IT/D359:IT)
R157	1-249-409-11	CARBON	220 5% 1/4W	TM701	1-537-494-11	TERMINAL BOARD (SPEAKER)	(A37/D309:AEP, EE, CIS/D359:AEP, UK)
R158	1-249-441-11	CARBON	100K 5% 1/4W				
R159	1-249-409-11	CARBON	220 5% 1/4W				
R161	1-249-417-11	CARBON	1K 5% 1/4W				
R162	1-247-903-00	CARBON	1M 5% 1/4W				

R163	1-249-417-11	CARBON	1K 5% 1/4W	*	1-646-980-21	MIC BOARD (A37)	
R164	1-247-903-00	CARBON	1M 5% 1/4W				
R165	1-249-413-11	CARBON	470 5% 1/4W				
R166	1-247-903-00	CARBON	1M 5% 1/4W				
R181	1-249-437-11	CARBON	47K 5% 1/4W	< CAPACITOR >			
R182	1-249-437-11	CARBON	47K 5% 1/4W (A37)	C901	1-124-925-11	ELECT 2.2uF 20% 100V	
R183	1-249-437-11	CARBON	47K 5% 1/4W	C902	1-162-294-31	CERAMIC 0.001uF 10% 50V	
R191	1-249-417-11	CARBON	1K 5% 1/4W	C903	1-162-219-31	CERAMIC 68PF 5% 50V	
			(D309:G, IT/D359:IT)	C904	1-162-284-31	CERAMIC 150PF 10% 50V	
				C905	1-124-464-11	ELECT 0.22uF 20% 50V	

The components identified by mark Δ or dotted line with mark Δ are critical for safety. Replace only with part number specified.

MIC PANEL

Ref. No.	Part No.	Description	Remark	Ref. No.	Part No.	Description	Remark
C906	1-124-477-11	ELECT 47uF 20% 25V		C239	1-124-126-00	ELECT 47uF 20% 10V	
C956	1-124-477-11	ELECT 47uF 20% 25V		C240	1-124-126-00	ELECT 47uF 20% 10V	
		< IC >		C241	1-124-903-11	ELECT 1uF 20% 50V	
IC901	8-759-634-51	IC M5218AP		C242	1-124-443-00	ELECT 100uF 20% 10V	
		< JACK >		C281	1-164-066-11	CERAMIC 68PF 5% 50V	
* J901	1-573-151-21	JACK, LARGE TYPE (MIC)		C282	1-164-070-11	CERAMIC 100PF 5% 50V	
		< RESISTOR >		C283	1-124-907-11	ELECT 10uF 20% 50V	
R901	1-249-429-11	CARBON 10K 5% 1/4W		C284	1-124-257-00	ELECT 2.2uF 20% 50V	
R902	1-249-417-11	CARBON 1K 5% 1/4W		C285	1-162-282-31	CERAMIC 100PF 10% 50V	
R903	1-249-441-11	CARBON 100K 5% 1/4W		C287	1-124-252-00	ELECT 0.33uF 20% 50V	
R904	1-249-412-11	CARBON 390 5% 1/4W		C288	1-136-160-00	FILM 0.039uF 5% 50V	
R905	1-249-441-11	CARBON 100K 5% 1/4W		C289	1-124-126-00	ELECT 47uF 20% 10V	
R906	1-249-417-11	CARBON 1K 5% 1/4W		C290	1-124-126-00	ELECT 47uF 20% 10V	
R907	1-249-429-11	CARBON 10K 5% 1/4W		C291	1-124-903-11	ELECT 1uF 20% 50V	
*****				C401	1-126-177-11	ELECT 100uF 20% 10V	
*	A-4356-896-A	PANEL BOARD, COMPLETE (D309:AEP)		C402	1-161-494-00	CERAMIC 0.022uF 25V	
		*****		C403	1-136-165-00	FILM 0.1uF 5% 50V	
*	A-4356-977-A	PANEL BOARD, COMPLETE (D359:AEP)		C404	1-161-379-00	CERAMIC 0.01uF 20% 25V	
		*****		C405	1-125-486-11	DOUBLE LAYERS 0.22F 5.5V	
*	A-4356-995-A	PANEL BOARD, COMPLETE (A37)		C406	1-126-157-11	ELECT 10uF 20% 16V	
		*****		C407	1-164-159-11	CERAMIC 0.1uF 50V	
*	A-4360-124-A	PANEL BOARD, COMPLETE (D309:G)		C411	1-126-177-11	ELECT 100uF 20% 10V	
		*****		C412	1-161-494-00	CERAMIC 0.022uF 25V	
*	A-4360-183-A	PANEL BOARD, COMPLETE (D309:IT)		C414	1-162-294-31	CERAMIC 0.001uF 10% 50V	
		*****		C415	1-162-294-31	CERAMIC 0.001uF 10% 50V	
*	A-4360-500-A	PANEL BOARD, COMPLETE (D359:IT)		C416	1-162-294-31	CERAMIC 0.001uF 10% 50V	
		*****		C417	1-162-294-31	CERAMIC 0.001uF 10% 50V	
*	A-4360-812-A	PANEL BOARD, COMPLETE (D309:EE, CIS)		C441	1-126-177-11	ELECT 100uF 20% 10V	
		*****		C442	1-164-159-11	CERAMIC 0.1uF 50V	
*	A-4360-917-A	PANEL BOARD, COMPLETE (D359:UK)		C443	1-126-177-11	ELECT 100uF 20% 10V	
		*****		C444	1-164-159-11	CERAMIC 0.1uF 50V	
		< CAPACITOR >		C445	1-130-471-00	MYLAR 0.001uF 5% 50V	
C231	1-164-066-11	CERAMIC 68PF 5% 50V		C446	1-126-163-11	ELECT 4.7uF 20% 50V	
C232	1-164-070-11	CERAMIC 100PF 5% 50V		C447	1-126-163-11	ELECT 4.7uF 20% 50V	
C233	1-124-907-11	ELECT 10uF 20% 50V		C448	1-126-157-11	ELECT 10uF 20% 16V	
C234	1-124-257-00	ELECT 2.2uF 20% 50V		C601	1-126-177-11	ELECT 100uF 20% 10V	
C235	1-162-282-31	CERAMIC 100PF 10% 50V		C602	1-164-159-11	CERAMIC 0.1uF 50V	
C236	1-164-159-11	CERAMIC 0.1uF 50V		C604	1-126-157-11	ELECT 10uF 20% 16V	
C237	1-124-252-00	ELECT 0.33uF 20% 50V		C605	1-124-916-11	ELECT 22uF 20% 63V	
C238	1-136-160-00	FILM 0.039uF 5% 50V		C606	1-162-202-31	CERAMIC 13PF 5% 50V	
				C607	1-162-202-31	CERAMIC 13PF 5% 50V	
				C608	1-126-163-11	ELECT 4.7uF 20% 50V	
				C609	1-136-153-00	FILM 0.01uF 5% 50V	
				C610	1-164-159-11	CERAMIC 0.1uF 50V	
						< FILTER >	
				CF401	1-567-775-11	VIBRATOR, CERAMIC (4.19MHz)	

Ref.No.	Part No.	Description	Remark	Ref.No.	Part No.	Description	Remark
		< CONNECTOR >					
* CN202	1-568-826-11	SOCKET, CONNECTOR 7P		D600	8-719-987-63	DIODE 1N4148M	
* CN401	1-568-830-11	SOCKET, CONNECTOR 11P		D601	8-719-987-63	DIODE 1N4148M	
* CN601	1-568-828-11	SOCKET, CONNECTOR 9P		D602	8-719-987-63	DIODE 1N4148M	
		< COMPOSITION CIRCUIT BLOCK >		D603	8-719-987-63	DIODE 1N4148M	
CP431	1-239-054-11	COMPOSITION CIRCUIT BLOCK		D604	8-719-987-63	DIODE 1N4148M	
CP432	1-239-054-11	COMPOSITION CIRCUIT BLOCK					
		< DIODE >		D605	8-719-987-63	DIODE 1N4148M (D309:AEP, D359:AEP, UK)	
D231	8-719-987-63	DIODE 1N4148M		D606	8-719-987-63	DIODE 1N4148M (D309:IT/D359:IT)	
D232	8-719-987-63	DIODE 1N4148M		D607	8-719-987-63	DIODE 1N4148M (D309:EE, CIS)	
D281	8-719-987-63	DIODE 1N4148M		D608	8-719-987-63	DIODE 1N4148M (A37/D309:EE, CIS)	
D401	8-719-200-82	DIODE 11ES2		D609	8-719-987-63	DIODE 1N4148M	
D402	8-719-987-63	DIODE 1N4148M					
D403	8-719-200-82	DIODE 11ES2		D610	8-719-987-63	DIODE 1N4148M	
D404	8-719-987-63	DIODE 1N4148M		D611	8-719-987-63	DIODE 1N4148M (A37)	
D405	8-719-200-82	DIODE 11ES2		D612	8-719-987-63	DIODE 1N4148M	
D406	8-719-200-82	DIODE 11ES2		D613	8-719-987-63	DIODE 1N4148M	
D407	8-719-200-82	DIODE 11ES2		D614	8-719-987-63	DIODE 1N4148M	
D410	8-719-987-63	DIODE 1N4148M		D615	8-719-987-63	DIODE 1N4148M	
D411	8-719-987-63	DIODE 1N4148M		D616	8-719-987-63	DIODE 1N4148M	
D412	8-719-987-63	DIODE 1N4148M		D617	8-719-987-63	DIODE 1N4148M	
D413	8-719-987-63	DIODE 1N4148M		D618	8-719-987-63	DIODE 1N4148M	
D414	8-719-987-63	DIODE 1N4148M		D619	8-719-987-63	DIODE 1N4148M	
D415	8-719-987-63	DIODE 1N4148M		D620	8-719-987-63	DIODE 1N4148M	
D416	8-719-987-63	DIODE 1N4148M				< FLUORESCENT INDICATOR >	
D418	8-719-200-82	DIODE 11ES2		FL431	1-519-648-21	INDICATOR TUBE, FLUORESCENT	
D419	8-719-200-82	DIODE 11ES2		FL601	1-519-732-11	INDICATOR TUBE, FLUORESCENT	
D420	8-719-200-82	DIODE 11ES2				< IC >	
D422	8-719-301-37	LED SEL2210S-CD		IC211	8-759-634-51	IC M5218AP	
D423	8-719-301-37	LED SEL2210S-CD		IC212	8-759-000-48	IC MC14052BCP	
D424	8-719-301-37	LED SEL2210S-CD		IC401	8-759-635-63	IC M51943BSL	
D425	8-719-301-37	LED SEL2210S-CD		IC402	8-759-160-26	IC uPD75104CW-286	
D426	8-719-301-37	LED SEL2210S-CD		IC403	8-759-820-62	IC LB1639	
D427	8-719-301-37	LED SEL2210S-CD		IC431	8-759-065-88	IC XR-1095	
D428	8-719-301-37	LED SEL2210S-CD		IC601	8-759-157-67	IC TMP47C1270AN-H211	
D429	8-719-301-37	LED SEL2210S-CD		IC602	8-749-922-36	IC GPIU50XB	
D430	8-719-301-37	LED SEL2210S-CD				< COIL >	
D431	8-719-301-37	LED SEL2210S-CD		L401	1-408-080-00	INDUCTOR 100uH	
D432	8-719-301-37	LED SEL2210S-CD		L403	1-410-521-11	INDUCTOR 100uH	
D433	8-719-301-37	LED SEL2210S-CD		L451	1-408-080-00	INDUCTOR 100uH	
D434	8-719-301-37	LED SEL2210S-CD		L601	1-410-521-11	INDUCTOR 100uH	
D435	8-719-301-37	LED SEL2210S-CD				< TRANSISTOR >	
D436	8-719-301-37	LED SEL2210S-CD		Q231	8-729-224-61	TRANSISTOR 2SK246-Y	
D437	8-719-301-37	LED SEL2210S-CD		Q232	8-729-119-78	TRANSISTOR 2SC2785-HFE (D309)	
D438	8-719-301-37	LED SEL2210S-CD		Q232	8-729-620-05	TRANSISTOR 2SC2603-EF (A37/D359)	
D439	8-719-301-37	LED SEL2210S-CD		Q233	8-729-900-63	TRANSISTOR DTA124ES	
D440	8-719-313-69	DIODE SEL3210S-CD		Q241	8-729-141-26	TRANSISTOR 2SC3622A-LK	
D441	8-719-301-37	LED SEL2210S-CD		Q242	8-729-900-36	TRANSISTOR DTC124ES	

PANEL

Ref. No.	Part No.	Description	Remark	Ref. No.	Part No.	Description	Remark
Q243	8-729-900-63	TRANSISTOR	DTA124ES	R402	1-249-435-11	CARBON	33K 5% 1/4W
Q281	8-729-224-61	TRANSISTOR	2SK246-Y	R403	1-249-429-11	CARBON	10K 5% 1/4W
Q282	8-729-119-78	TRANSISTOR	2SC2785-HFE (D309)	R404	1-249-437-11	CARBON	47K 5% 1/4W
Q282	8-729-620-05	TRANSISTOR	2SC2603-EF (A37/D359)	R406	1-249-405-11	CARBON	100 5% 1/4W
Q291	8-729-141-26	TRANSISTOR	2SC3622A-LK	R409	1-249-433-11	CARBON	22K 5% 1/4W
Q401	8-729-119-78	TRANSISTOR	2SC2785-HFE (D309)	R410	1-249-433-11	CARBON	22K 5% 1/4W
Q401	8-729-620-05	TRANSISTOR	2SC2603-EF (A37/D359)	R411	1-249-429-11	CARBON	10K 5% 1/4W
Q432	8-729-900-63	TRANSISTOR	DTA124ES	R412	1-249-433-11	CARBON	22K 5% 1/4W
Q433	8-729-900-63	TRANSISTOR	DTA124ES	R413	1-249-433-11	CARBON	22K 5% 1/4W
Q434	8-729-119-78	TRANSISTOR	2SC2785-HFE (D309)	R414	1-249-433-11	CARBON	22K 5% 1/4W
Q434	8-729-620-05	TRANSISTOR	2SC2603-EF (A37/D359)	R415	1-249-433-11	CARBON	22K 5% 1/4W
Q435	8-729-119-78	TRANSISTOR	2SC2785-HFE (D309)	R416	1-249-417-11	CARBON	1K 5% 1/4W
Q435	8-729-620-05	TRANSISTOR	2SC2603-EF (A37/D359)	R417	1-249-417-11	CARBON	1K 5% 1/4W
Q601	8-729-119-78	TRANSISTOR	2SC2785-HFE (D309)	R418	1-249-417-11	CARBON	1K 5% 1/4W
Q601	8-729-620-05	TRANSISTOR	2SC2603-EF (A37/D359)	R419	1-249-433-11	CARBON	22K 5% 1/4W
Q602	8-729-119-78	TRANSISTOR	2SC2785-HFE (D309)	R422	1-249-412-11	CARBON	390 5% 1/4W
Q602	8-729-620-05	TRANSISTOR	2SC2603-EF (A37/D359)	R423	1-249-412-11	CARBON	390 5% 1/4W
< RESISTOR >				R424	1-249-412-11	CARBON	390 5% 1/4W
R230	1-247-903-00	CARBON	1M 5% 1/4W	R425	1-249-412-11	CARBON	390 5% 1/4W
R231	1-249-417-11	CARBON	1K 5% 1/4W	R426	1-249-412-11	CARBON	390 5% 1/4W
R232	1-247-903-00	CARBON	1M 5% 1/4W	R427	1-249-411-11	CARBON	330 5% 1/4W
R233	1-249-429-11	CARBON	10K 5% 1/4W	R428	1-249-412-11	CARBON	390 5% 1/4W
R234	1-249-421-11	CARBON	2.2K 5% 1/4W	R429	1-249-412-11	CARBON	390 5% 1/4W
R235	1-249-423-11	CARBON	3.3K 5% 1/4W	R430	1-249-415-11	CARBON	680 5% 1/4W
R236	1-249-437-11	CARBON	47K 5% 1/4W	R442	1-249-418-11	CARBON	1.2K 5% 1/4W
R237	1-249-412-11	CARBON	390 5% 1/4W	R443	1-249-409-11	CARBON	220 5% 1/4W
R238	1-249-427-11	CARBON	6.8K 5% 1/4W	R444	1-249-441-11	CARBON	100K 5% 1/4W
R239	1-247-903-00	CARBON	1M 5% 1/4W	R445	1-249-409-11	CARBON	220 5% 1/4W
R240	1-249-435-11	CARBON	33K 5% 1/4W	R446	1-249-441-11	CARBON	100K 5% 1/4W
R241	1-249-432-11	CARBON	18K 5% 1/4W	R447	1-247-897-11	CARBON	560K 5% 1/4W
R242	1-249-429-11	CARBON	10K 5% 1/4W	R448	1-247-897-11	CARBON	560K 5% 1/4W
R243	1-249-433-11	CARBON	22K 5% 1/4W	R449	1-249-427-11	CARBON	6.8K 5% 1/4W
R244	1-249-433-11	CARBON	22K 5% 1/4W	R450	1-249-436-11	CARBON	39K 5% 1/4W
R245	1-249-433-11	CARBON	22K 5% 1/4W	R499	1-249-427-11	CARBON	6.8K 5% 1/4W
R247	1-249-433-11	CARBON	22K 5% 1/4W	R500	1-249-436-11	CARBON	39K 5% 1/4W
R248	1-249-433-11	CARBON	22K 5% 1/4W	R601	1-249-405-11	CARBON	100 5% 1/4W
R249	1-249-425-11	CARBON	4.7K 5% 1/4W	R602	1-249-417-11	CARBON	1K 5% 1/4W
R280	1-247-903-00	CARBON	1M 5% 1/4W	R603	1-249-429-11	CARBON	10K 5% 1/4W
R281	1-249-417-11	CARBON	1K 5% 1/4W	R604	1-249-425-11	CARBON	4.7K 5% 1/4W
R282	1-247-903-00	CARBON	1M 5% 1/4W	R605	1-249-441-11	CARBON	100K 5% 1/4W
R283	1-249-429-11	CARBON	10K 5% 1/4W	R606	1-249-405-11	CARBON	100 5% 1/4W
R284	1-249-421-11	CARBON	2.2K 5% 1/4W	R607	1-249-409-11	CARBON	220 5% 1/4W
R285	1-249-423-11	CARBON	3.3K 5% 1/4W	R608	1-249-409-11	CARBON	220 5% 1/4W
R286	1-249-437-11	CARBON	47K 5% 1/4W	R609	1-249-409-11	CARBON	220 5% 1/4W
R287	1-249-412-11	CARBON	390 5% 1/4W	R610	1-249-409-11	CARBON	220 5% 1/4W
R288	1-249-427-11	CARBON	6.8K 5% 1/4W	R611	1-249-421-11	CARBON	2.2K 5% 1/4W
R289	1-247-903-00	CARBON	1M 5% 1/4W	R612	1-249-423-11	CARBON	3.3K 5% 1/4W
R299	1-249-425-11	CARBON	4.7K 5% 1/4W	R613	1-249-441-11	CARBON	100K 5% 1/4W
R401	1-249-417-11	CARBON	1K 5% 1/4W	R614	1-249-441-11	CARBON	100K 5% 1/4W
				R615	1-249-441-11	CARBON	100K 5% 1/4W

Ref. No.	Part No.	Description	Remark
C1707	1-162-288-31	CERAMIC 330PF 10%	50V
C1708	1-124-903-11	ELECT 1uF 20%	50V
C1709	1-124-903-11	ELECT 1uF 20%	50V
C1710	1-130-471-00	MYLAR 0.001uF 5%	50V
C1710	1-137-364-91	FILM 0.001uF 5%	50V
C1711	1-130-471-00	MYLAR 0.001uF 5%	50V
C1711	1-137-364-91	FILM 0.001uF 5%	50V
C1712	1-130-736-11	FILM 0.01uF 5%	50V
C1713	1-130-736-11	FILM 0.01uF 5%	50V
C1714	1-124-903-11	ELECT 1uF 20%	50V
C1715	1-124-903-11	ELECT 1uF 20%	50V
C1716	1-124-903-11	ELECT 1uF 20%	50V
C1717	1-162-291-31	CERAMIC 560PF 10%	50V
C1718	1-162-291-31	CERAMIC 560PF 10%	50V
C1719	1-124-477-11	ELECT 47uF 20%	25V
C1720	1-161-379-00	CERAMIC 0.01uF 20%	25V
C1721	1-161-379-00	CERAMIC 0.01uF 20%	25V
C1722	1-161-379-00	CERAMIC 0.01uF 20%	25V
C1723	1-161-379-00	CERAMIC 0.01uF 20%	25V
C1724	1-161-379-00	CERAMIC 0.01uF 20%	25V
C1725	1-124-477-11	ELECT 47uF 20%	25V
C1726	1-124-903-11	ELECT 1uF 20%	50V
C1727	1-124-903-11	ELECT 1uF 20%	50V
C1728	1-124-034-51	ELECT 33uF 20%	16V
C1729	1-124-907-11	ELECT 10uF 20%	50V
< CONNECTOR >			
* CN1701	1-568-832-11	SOCKET, CONNECTOR 13P	
< DIODE >			
D1701	8-719-987-63	DIODE 1N4148M	
D1702	8-719-987-63	DIODE 1N4148M	
D1703	8-719-987-63	DIODE 1N4148M	
D1704	8-719-987-63	DIODE 1N4148M	
D1705	8-719-987-63	DIODE 1N4148M	
< IC >			
IC1701	8-759-063-04	IC IR3R42	
IC1702	8-759-634-51	IC M5218AP	
IC1703	8-759-140-53	IC MC14053BCP	
< COIL >			
L1701	1-409-497-11	COIL (FILTER)	
< TRANSISTOR >			
Q1701	8-729-900-61	TRANSISTOR DTA114ES	
Q1702	8-729-900-80	TRANSISTOR DTC114ES	
Q1703	8-729-900-80	TRANSISTOR DTC114ES	
Q1704	8-729-900-80	TRANSISTOR DTC114ES	
Q1705	8-729-900-61	TRANSISTOR DTA114ES	

Ref. No.	Part No.	Description	Remark
< RESISTOR >			
R1701	1-249-432-11	CARBON 18K 5%	1/4W
R1702	1-249-435-11	CARBON 33K 5%	1/4W
R1703	1-249-427-11	CARBON 6.8K 5%	1/4W
R1704	1-247-858-11	CARBON 13K 5%	1/4W
R1705	1-249-417-11	CARBON 1K 5%	1/4W
R1706	1-249-417-11	CARBON 1K 5%	1/4W
R1707	1-249-441-11	CARBON 100K 5%	1/4W
R1708	1-249-440-11	CARBON 82K 5%	1/4W
R1709	1-249-439-11	CARBON 68K 5%	1/4W
R1710	1-249-439-11	CARBON 68K 5%	1/4W
R1711	1-249-439-11	CARBON 68K 5%	1/4W
R1712	1-247-878-00	CARBON 91K 5%	1/4W
R1713	1-247-878-00	CARBON 91K 5%	1/4W
R1714	1-249-441-11	CARBON 100K 5%	1/4W
R1715	1-249-441-11	CARBON 100K 5%	1/4W
R1716	1-249-441-11	CARBON 100K 5%	1/4W
R1717	1-249-441-11	CARBON 100K 5%	1/4W
R1718	1-249-429-11	CARBON 10K 5%	1/4W
R1719	1-249-429-11	CARBON 10K 5%	1/4W
R1720	1-249-429-11	CARBON 10K 5%	1/4W
R1721	1-249-434-11	CARBON 27K 5%	1/4W
R1722	1-249-441-11	CARBON 100K 5%	1/4W
< VARIABLE RESISTOR >			
RV1701	1-238-601-11	RES, ADJ, CARBON 22K	
RV1702	1-238-599-11	RES, ADJ, CARBON 4.7K	
< SWITCH >			
S1701	1-571-303-11	SWITCH, SLIDE	
< TEST PIN >			
* TP1701	1-560-061-00	PIN, CONNECTOR 3P	
* TP1702	1-560-061-00	PIN, CONNECTOR 3P	

* A-4356-906-A	POWER BOARD, COMPLETE (D309)		

* A-4356-987-A	POWER BOARD, COMPLETE (D359:AEP, IT)		

* A-4356-993-A	POWER BOARD, COMPLETE (D359:UK)		

* A-4360-001-A	POWER BOARD, COMPLETE (A37)		

< CAPACITOR >			
△C1	1-161-744-00	CERAMIC 0.01uF	400V

The components identified by mark △ or dotted line with mark △ are critical for safety. Replace only with part number specified.

POWER AMPLIFIER

Ref. No.	Part No.	Description	Remark	Ref. No.	Part No.	Description	Remark
		< CONNECTOR >					
* CN241	1-564-518-11	PLUG, CONNECTOR 3P		R721	1-247-881-00	CARBON 120K 5% 1/4W	
		< DIODE >		R722	1-249-437-11	CARBON 47K 5% 1/4W	
D701	8-719-987-63	DIODE 1N4148M		R723	1-249-439-11	CARBON 68K 5% 1/4W	
D751	8-719-987-63	DIODE 1N4148M					
		< IC >		R724	1-249-417-11	CARBON 1K 5% 1/4W	
IC701	8-749-920-22	IC STK-4172MK2K (A37)		R725	1-249-433-11	CARBON 22K 5% 1/4W	
IC701	8-749-920-09	IC STK-4152MK2K (D309/D359)		R726	1-249-433-11	CARBON 22K 5% 1/4W	
		< COIL >		R727	1-249-426-11	CARBON 5.6K 5% 1/4W	
L701	1-420-872-00	COIL, AIR CORE		△R739	1-249-383-81	CARBON 1.5 5% 1/4W	F
L751	1-420-872-00	COIL, AIR CORE					
		< TRANSISTOR >		R751	1-249-417-11	CARBON 1K 5% 1/4W	
Q701	8-729-140-84	TRANSISTOR 2SC1841-PAFAEA		R752	1-249-438-11	CARBON 56K 5% 1/4W	
Q702	8-729-900-80	TRANSISTOR DTC114ES		R753	1-249-414-11	CARBON 560 5% 1/4W	
Q703	8-729-119-78	TRANSISTOR 2SC2785-HFE (D309)		R754	1-249-438-11	CARBON 56K 5% 1/4W	
Q703	8-729-620-05	TRANSISTOR 2SC2603-EF (A37/D359)		R755	1-249-425-11	CARBON 4.7K 5% 1/4W	(D309/D359)
Q751	8-729-140-84	TRANSISTOR 2SC1841-PAFAEA					
		< RESISTOR >		R755	1-249-427-11	CARBON 6.8K 5% 1/4W	(A37)
R701	1-249-417-11	CARBON 1K 5% 1/4W		R756	1-249-425-11	CARBON 4.7K 5% 1/4W	(D309/D359)
R702	1-249-438-11	CARBON 56K 5% 1/4W					
R703	1-249-414-11	CARBON 560 5% 1/4W		R756	1-249-427-11	CARBON 6.8K 5% 1/4W	(A37)
R704	1-249-438-11	CARBON 56K 5% 1/4W		R757	1-249-425-11	CARBON 4.7K 5% 1/4W	(D309/D359)
R705	1-249-425-11	CARBON 4.7K 5% 1/4W	(D309/D359)				
				R757	1-249-427-11	CARBON 6.8K 5% 1/4W	(A37)
R705	1-249-427-11	CARBON 6.8K 5% 1/4W	(A37)				
R706	1-249-425-11	CARBON 4.7K 5% 1/4W	(D309/D359)	R758	1-249-425-11	CARBON 4.7K 5% 1/4W	(D309/D359)
R706	1-249-427-11	CARBON 6.8K 5% 1/4W	(A37)	R758	1-249-427-11	CARBON 6.8K 5% 1/4W	(A37)
R707	1-249-425-11	CARBON 4.7K 5% 1/4W	(D309/D359)	R759	1-249-421-11	CARBON 2.2K 5% 1/4W	
				R760	1-249-421-11	CARBON 2.2K 5% 1/4W	
R707	1-249-427-11	CARBON 6.8K 5% 1/4W	(A37)	△R761	1-212-881-11	FUSIBLE 100 5% 1/4W	F
R708	1-249-425-11	CARBON 4.7K 5% 1/4W	(D309/D359)				
				△R762	1-217-151-00	METAL PLATE 0.22 2W	
R708	1-249-427-11	CARBON 6.8K 5% 1/4W	(A37)				
R709	1-249-421-11	CARBON 2.2K 5% 1/4W		R763	1-249-397-11	CARBON 22 5% 1/4W	
R710	1-249-421-11	CARBON 2.2K 5% 1/4W		R764	1-249-397-11	CARBON 22 5% 1/4W	
△R711	1-212-881-11	FUSIBLE 100 5% 1/4W	F	R765	1-249-417-11	CARBON 1K 5% 1/4W	
△R712	1-217-151-00	METAL PLATE 0.22 2W		R766	1-249-431-11	CARBON 15K 5% 1/4W	
R713	1-249-397-11	CARBON 22 5% 1/4W					
				R767	1-249-441-11	CARBON 100K 5% 1/4W	
R714	1-249-397-11	CARBON 22 5% 1/4W		R768	1-249-397-11	CARBON 22 5% 1/4W	
R715	1-249-417-11	CARBON 1K 5% 1/4W		R769	1-249-397-11	CARBON 22 5% 1/4W	
R716	1-249-431-11	CARBON 15K 5% 1/4W					
R717	1-249-441-11	CARBON 100K 5% 1/4W					
R718	1-249-397-11	CARBON 22 5% 1/4W					
R719	1-249-397-11	CARBON 22 5% 1/4W					
R720	1-249-429-11	CARBON 10K 5% 1/4W					

The components identified by mark \triangle or dotted line with mark \triangle are critical for safety. Replace only with part number specified.

Ref. No.	Part No.	Description	Remark	Ref. No.	Part No.	Description	Remark
*	A-4356-901-A	ST MAIN BOARD, COMPLETE (D309:AEP) *****		C259	1-124-902-00	ELECT 0.47uF 20% 50V	
*	A-4356-982-A	ST MAIN BOARD, COMPLETE (D359:AEP) *****		C260	1-136-153-00	FILM 0.01uF 5% 50V	
*	A-4356-989-A	ST MAIN BOARD, COMPLETE (D359:UK) *****		C261	1-136-168-00	FILM 0.18uF 5% 50V	
*	A-4356-998-A	ST MAIN BOARD, COMPLETE (A37) *****		C262	1-130-478-00	MYLAR 0.0039uF 5% 50V	
*	A-4360-123-A	ST MAIN BOARD, COMPLETE (D309:G, IT) *****		C263	1-136-163-00	FILM 0.068uF 5% 50V	
*	A-4360-503-A	ST MAIN BOARD, COMPLETE (D359:IT) *****		C264	1-130-474-00	MYLAR 0.0018uF 5% 50V	
*	A-4360-814-A	ST MAIN BOARD, COMPLETE (D309:EE) *****		C265	1-136-159-00	FILM 0.033uF 5% 50V	
*	A-4360-817-A	ST MAIN BOARD, COMPLETE (D309:CIS) *****		C266	1-130-469-00	MYLAR 680PF 5% 50V	
		< CAPACITOR >		C267	1-136-154-00	FILM 0.012uF 5% 50V	
C202	1-110-339-11	MYLAR 220PF 5% 50V		C268	1-110-340-11	MYLAR 270PF 5% 50V	
C203	1-130-471-00	MYLAR 0.001uF 5% 50V		C269	1-130-479-00	MYLAR 0.0047uF 5% 50V	
C204	1-124-907-11	ELECT 10uF 20% 50V		C270	1-124-916-11	ELECT 22uF 20% 63V	
C205	1-124-907-11	ELECT 10uF 20% 50V		C301	1-161-379-00	CERAMIC 0.01uF 20% 25V (D309:G, IT/D359:IT)	
C206	1-136-163-00	FILM 0.068uF 5% 50V		C302	1-124-477-11	ELECT 47uF 20% 25V	
C207	1-124-903-11	ELECT 1uF 20% 50V		C303	1-161-379-00	CERAMIC 0.01uF 20% 25V	
C208	1-136-158-00	FILM 0.027uF 5% 50V		C305	1-161-379-00	CERAMIC 0.01uF 20% 25V (D309:G, IT/D359:IT)	
C209	1-124-902-00	ELECT 0.47uF 20% 50V		C306	1-161-379-00	CERAMIC 0.01uF 20% 25V (D309:G, IT/D359:IT)	
C210	1-136-153-00	FILM 0.01uF 5% 50V		C307	1-161-379-00	CERAMIC 0.01uF 20% 25V	
C211	1-136-168-00	FILM 0.18uF 5% 50V		C308	1-161-379-00	CERAMIC 0.01uF 20% 25V	
C212	1-130-478-00	MYLAR 0.0039uF 5% 50V		C309	1-161-379-00	CERAMIC 0.01uF 20% 25V	
C213	1-136-163-00	FILM 0.068uF 5% 50V		C310	1-124-477-11	ELECT 47uF 20% 25V	
C214	1-130-474-00	MYLAR 0.0018uF 5% 50V		C311	1-161-379-00	CERAMIC 0.01uF 20% 25V	
C215	1-136-159-00	FILM 0.033uF 5% 50V		C312	1-101-006-00	CERAMIC 0.047uF 50V	
C216	1-130-469-00	MYLAR 680PF 5% 50V		C313	1-123-382-00	ELECT 3.3uF 20% 100V	
C217	1-136-154-00	FILM 0.012uF 5% 50V		C314	1-161-379-00	CERAMIC 0.01uF 20% 25V	
C218	1-110-340-11	MYLAR 270PF 5% 50V		C315	1-161-329-00	CERAMIC 0.0068uF 30% 16V	
C219	1-130-479-00	MYLAR 0.0047uF 5% 50V		C316	1-162-282-31	CERAMIC 100PF 10% 50V	
C220	1-124-916-11	ELECT 22uF 20% 63V		C317	1-162-292-31	CERAMIC 680PF 10% 50V (D309:G, IT/D359:IT)	
C221	1-164-159-11	CERAMIC 0.1uF 50V		C318	1-124-903-11	ELECT 1uF 20% 50V	
C222	1-164-159-11	CERAMIC 0.1uF 50V		C320	1-124-903-11	ELECT 1uF 20% 50V	
C223	1-164-159-11	CERAMIC 0.1uF 50V		C321	1-124-902-00	ELECT 0.47uF 20% 50V	
C252	1-110-339-11	MYLAR 220PF 5% 50V		C322	1-124-463-00	ELECT 0.1uF 20% 50V	
C253	1-130-471-00	MYLAR 0.001uF 5% 50V		C323	1-161-329-00	CERAMIC 0.0068uF 20% 16V	
C254	1-124-907-11	ELECT 10uF 20% 50V		C324	1-161-329-00	CERAMIC 0.0068uF 20% 16V	
C255	1-124-907-11	ELECT 10uF 20% 50V		C325	1-124-477-11	ELECT 47uF 20% 25V	
C256	1-136-163-00	FILM 0.068uF 5% 50V		C326	1-124-907-11	ELECT 10uF 20% 50V	
C257	1-124-903-11	ELECT 1uF 20% 50V		C327	1-161-379-00	CERAMIC 0.01uF 20% 25V	
C258	1-136-158-00	FILM 0.027uF 5% 50V		C328	1-124-463-00	ELECT 0.1uF 20% 50V	
				C329	1-124-927-11	ELECT 4.7uF 20% 100V	
				C330	1-161-379-00	CERAMIC 0.01uF 20% 25V	
				C331	1-126-176-11	ELECT 220uF 20% 10V	
				C332	1-161-379-00	CERAMIC 0.01uF 20% 25V	
				C335	1-161-379-00	CERAMIC 0.01uF 20% 25V	
				C336	1-161-379-00	CERAMIC 0.01uF 20% 25V	
				C339	1-162-210-31	CERAMIC 30PF 5% 50V (D309:AEP, EE, CIS/D359:AEP, UK)	
				C341	1-123-382-00	ELECT 3.3uF 20% 100V	

ST MAIN

Ref. No.	Part No.	Description	Remark	Ref. No.	Part No.	Description	Remark
C342	1-123-382-00	ELECT 3. 3uF 20% 100V		CF303	1-567-389-11	FILTER, CERAMIC (D309:G, IT/D359:IT)	
C343	1-123-382-00	ELECT 3. 3uF 20% 100V		CF303	1-577-070-81	FILTER, CERAMIC (A37/D309:AEP, EE, CIS/D359:AEP, UK)	
C344	1-123-382-00	ELECT 3. 3uF 20% 100V		CF304	1-577-075-11	OSCILLATOR, CERAMIC	
C345	1-161-375-00	CERAMIC 0. 0022uF 20% 50V				< CONNECTOR >	
C346	1-161-375-00	CERAMIC 0. 0022uF 20% 50V					
C351	1-161-494-00	CERAMIC 0. 022uF 25V (D309:AEP, EE, CIS/D359:AEP, UK)		* CN201	1-568-826-11	SOCKET, CONNECTOR 7P	
C352	1-102-120-00	CERAMIC 0. 0018uF 10% 50V (D309:AEP, EE, CIS/D359:AEP, UK)		* CN301	1-568-832-11	SOCKET, CONNECTOR 13P (D309:CIS)	
C353	1-161-374-11	CERAMIC 0. 0015uF 20% 50V (D309:AEP, EE, CIS/D359:AEP, UK)		* CN501	1-568-828-11	SOCKET, CONNECTOR 9P	
C354	1-161-494-00	CERAMIC 0. 022uF 25V (D309:AEP, EE, CIS/D359:AEP, UK)		CNJ131	1-695-095-11	SOCKET, CONNECTOR 13P	
C361	1-164-098-11	CERAMIC 0. 047uF 12V		CNJ132	1-750-179-11	SOCKET, CONNECTOR 5P	
C362	1-161-494-00	CERAMIC 0. 022uF 25V				< COMPOSITION CIRCUIT BLOCK >	
C363	1-164-159-11	CERAMIC 0. 1uF 50V (D309:AEP, EE, CIS/D359:AEP, UK)		CP201	1-239-053-11	COMPOSITION CIRCUIT BLOCK	
C364	1-161-494-00	CERAMIC 0. 022uF 25V (D309:AEP, EE, CIS/D359:AEP, UK)		CP251	1-239-053-11	COMPOSITION CIRCUIT BLOCK	
C371	1-162-196-31	CERAMIC 5. 6PF 10% 50V (D309:AEP, EE, CIS/D359:AEP, UK)				< DIODE >	
C371	1-162-198-31	CERAMIC 8. 2PF 10% 50V (A37/D309:G, IT/D359:IT)		D351	8-719-987-63	DIODE 1N4148M (D309:AEP, EE, CIS/D359:AEP, UK)	
C373	1-162-288-31	CERAMIC 330PF 10% 50V (A37/D309:AEP, EE, CIS/D359:AEP, UK)		D391	8-719-987-63	DIODE 1N4148M (D309:CIS)	
C501	1-102-961-00	CERAMIC 27PF 5% 50V		D392	8-719-987-63	DIODE 1N4148M (D309:CIS)	
C502	1-102-961-00	CERAMIC 27PF 5% 50V				< FRONT END >	
C503	1-124-477-11	ELECT 47uF 20% 25V		FE301	1-463-857-21	FRONT END (FM) (D309:G, IT/D359:IT)	
C504	1-161-379-00	CERAMIC 0. 01uF 20% 25V		FE301	1-465-006-11	FRONT END (FM) (2 GANG) (D359:UK)	
C505	1-161-379-00	CERAMIC 0. 01uF 20% 25V		FE301	1-465-396-11	FRONT END (FM 3GANG) (D309:EE, CIS)	
C506	1-161-379-00	CERAMIC 0. 01uF 20% 25V		FE301	1-693-090-21	FRONT END (FM) (2 GANG) (A37/D309:AEP/D359:AEP)	
C507	1-161-379-00	CERAMIC 0. 01uF 20% 25V		FE351	1-236-463-11	ENCAPSULATED COMPONENT (D309:AEP, EE, CIS/D359:AEP, UK)	
C521	1-124-925-11	ELECT 2. 2uF 20% 100V		FE352	1-239-260-11	ENCAPSULATED COMPONENT (A37/D309:G, IT/D359:IT)	
C522	1-124-463-00	ELECT 0. 1uF 20% 50V		FE352	1-239-261-12	ENCAPSULATED COMPONENT (D309:AEP, EE, CIS/D359:AEP, UK)	
C523	1-161-379-00	CERAMIC 0. 01uF 20% 25V				< IC >	
C524	1-161-379-00	CERAMIC 0. 01uF 20% 25V		IC201	8-759-633-78	IC M5289P	
C525	1-124-477-11	ELECT 47uF 20% 25V (A37/D309:AEP, G, IT/D359)		IC202	8-759-804-49	IC LC7522 (A37/D359)	
C525	1-126-101-11	ELECT 100uF 20% 16V (D309:EE, CIS)		IC202	8-759-822-26	IC LC7522K (D309)	
C531	1-136-173-00	FILM 0. 47uF 5% 50V (D309:AEP, EE, CIS/D359:AEP, UK)		IC251	8-759-633-78	IC M5289P	
C532	1-161-494-00	CERAMIC 0. 022uF 25V (D309:AEP, EE, CIS/D359:AEP, UK)		IC301	8-759-821-45	IC LA1851N	
C533	1-124-463-00	ELECT 0. 1uF 20% 50V (D309:AEP, EE, CIS/D359:AEP, UK)		IC501	8-759-820-91	IC LC7218	
		< FILTER >				< IFT >	
CF301	1-567-389-11	FILTER, CERAMIC (D309:G, IT/D359:IT)		IFT301	1-404-713-11	TRANSFORMER, IF	
CF301	1-577-070-81	FILTER, CERAMIC (A37/D309:AEP, EE, CIS/D359:AEP, UK)				< COIL >	
CF302	1-567-389-11	FILTER, CERAMIC (D309:G, IT/D359:IT)		L301	1-410-686-11	INDUCTOR 1mH (A37/D309:G, IT/D359:IT)	
				L301	1-407-500-00	INDUCTOR 4. 7mH (D309:AEP, EE, CIS/D359:AEP, UK)	

Ref. No.	Part No.	Description	Remark	Ref. No.	Part No.	Description	Remark
L351	1-410-525-11	INDUCTOR 220uH (D309:AEP, EE, CIS/D359:AEP, UK)		R253	1-249-427-11	CARBON 6.8K 5% 1/4W	
		< FILTER >		R301	1-249-401-11	CARBON 47 5% 1/4W	
LPF301	1-235-164-00	FILTER, LOW PASS		R302	1-249-405-11	CARBON 100 5% 1/4W (D309:G, IT/D359:IT)	
LPF302	1-235-164-00	FILTER, LOW PASS		R302	1-249-407-11	CARBON 150 5% 1/4W (A37/D309:AEP/D359:AEP)	
		< TRANSISTOR >		R302	1-249-413-11	CARBON 470 5% 1/4W (D309:EE, CIS/D359:UK)	
Q301	8-729-230-99	TRANSISTOR 2SC2669-OY (D309:G, IT/D359:IT)		R303	1-249-411-11	CARBON 330 5% 1/4W (D309:G, IT/D359:IT)	
Q302	8-729-230-99	TRANSISTOR 2SC2669-OY (D309:G, IT/D359:IT)		R304	1-249-432-11	CARBON 18K 5% 1/4W (D309:G, IT/D359:IT)	
Q303	8-729-230-XX	TRANSISTOR 2SC2669-OY		R305	1-249-411-11	CARBON 330 5% 1/4W (D309:G, IT/D359:IT)	
Q304	8-729-230-XX	TRANSISTOR 2SC2669-OY		R306	1-249-434-11	CARBON 27K 5% 1/4W (D309:G, IT/D359:IT)	
Q305	8-729-900-80	TRANSISTOR DTC114ES		R307	1-249-414-11	CARBON 560 5% 1/4W (D309:G, IT/D359:IT)	
Q306	8-729-900-61	TRANSISTOR DTA114ES		R308	1-249-411-11	CARBON 330 5% 1/4W	
Q307	8-729-900-80	TRANSISTOR DTC114ES		R309	1-249-432-11	CARBON 18K 5% 1/4W	
Q308	8-729-119-78	TRANSISTOR 2SC2785-HFE (D309)		R310	1-249-411-11	CARBON 330 5% 1/4W	
Q308	8-729-620-05	TRANSISTOR 2SC2603-EF (A37/D359)		R311	1-249-434-11	CARBON 27K 5% 1/4W	
Q309	8-729-119-78	TRANSISTOR 2SC2785-HFE (D309)		R312	1-249-414-11	CARBON 560 5% 1/4W (A37/D309:AEP, EE, CIS/D359:AEP, UK)	
Q309	8-729-620-05	TRANSISTOR 2SC2603-EF (A37/D359)		R312	1-249-416-11	CARBON 820 5% 1/4W (D309:G, IT/D359:IT)	
Q351	8-729-900-80	TRANSISTOR DTC114ES (D309:AEP, EE, CIS/D359:AEP, UK)		R313	1-249-405-11	CARBON 100 5% 1/4W	
Q352	8-729-119-78	TRANSISTOR 2SC2785-HFE (D309:AEP, EE, CIS)		△R315	1-249-404-00	CARBON 82 5% 1/4W	
Q352	8-729-620-05	TRANSISTOR 2SC2603-EF (D359:AEP, UK)		R316	1-249-429-11	CARBON 10K 5% 1/4W	
Q353	8-729-119-76	TRANSISTOR 2SA1175-HFE (D309:AEP, EE, CIS/D359:AEP, UK)		R317	1-249-417-11	CARBON 1K 5% 1/4W	
Q354	8-729-900-80	TRANSISTOR DTC114ES (D309:AEP, EE, CIS/D359:AEP, UK)		R318	1-249-435-11	CARBON 33K 5% 1/4W	
Q355	8-729-900-80	TRANSISTOR DTC114ES (D309:AEP, EE, CIS/D359:AEP, UK)		R319	1-249-428-11	CARBON 8.2K 5% 1/4W	
Q356	8-729-900-80	TRANSISTOR DTC114ES (D309:AEP, EE, CIS/D359:AEP, UK)		R320	1-249-432-11	CARBON 18K 5% 1/4W	
Q501	8-729-900-80	TRANSISTOR DTC114ES		R321	1-249-423-11	CARBON 3.3K 5% 1/4W	
Q502	8-729-900-61	TRANSISTOR DTA114ES		R322	1-249-429-11	CARBON 10K 5% 1/4W	
Q521	8-729-202-67	TRANSISTOR 2SK246-GR3		R323	1-249-418-11	CARBON 1.2K 5% 1/4W (A37/D309:AEP, EE, CIS/D359:AEP, UK)	
Q522	8-729-201-84	TRANSISTOR 2SC3112-B		R323	1-249-423-11	CARBON 3.3K 5% 1/4W (D309:G, IT/D359:IT)	
Q531	8-729-202-67	TRANSISTOR 2SK246-GR3 (D309:AEP, EE, CIS/D359:AEP, UK)		R324	1-249-429-11	CARBON 10K 5% 1/4W	
Q532	8-729-201-84	TRANSISTOR 2SC3112-B (D309:AEP, EE, CIS/D359:AEP, UK)		R325	1-249-429-11	CARBON 10K 5% 1/4W	
		< RESISTOR >		R326	1-249-409-11	CARBON 220 5% 1/4W	
R201	1-249-427-11	CARBON 6.8K 5% 1/4W		R327	1-249-437-11	CARBON 47K 5% 1/4W	
R202	1-249-441-11	CARBON 100K 5% 1/4W		R328	1-249-437-11	CARBON 47K 5% 1/4W	
R203	1-249-427-11	CARBON 6.8K 5% 1/4W		R329	1-249-437-11	CARBON 47K 5% 1/4W (D309:G, IT/D359:IT)	
R211	1-249-417-11	CARBON 1K 5% 1/4W		R330	1-249-435-11	CARBON 33K 5% 1/4W (D309:G, IT/D359:IT)	
R212	1-249-417-11	CARBON 1K 5% 1/4W		R331	1-247-899-11	CARBON 680K 5% 1/4W	
R251	1-249-427-11	CARBON 6.8K 5% 1/4W		R332	1-247-899-11	CARBON 680K 5% 1/4W	
R252	1-249-441-11	CARBON 100K 5% 1/4W		R333	1-249-421-11	CARBON 2.2K 5% 1/4W	
				R334	1-249-421-11	CARBON 2.2K 5% 1/4W	
				R335	1-249-420-11	CARBON 1.8K 5% 1/4W	

The components identified by mark △ or dotted line with mark △ are critical for safety.
Replace only with part number specified.

Ref. No.	Part No.	Description	Remark
R336	1-249-420-11	CARBON 1.8K 5% 1/4W	
R337	1-249-426-11	CARBON 5.6K 5% 1/4W	
R338	1-249-426-11	CARBON 5.6K 5% 1/4W	
R351	1-249-433-11	CARBON 22K 5% 1/4W (D309:AEP, EE, CIS/D359:AEP, UK)	
R352	1-249-437-11	CARBON 47K 5% 1/4W (D309:AEP, EE, CIS/D359:AEP, UK)	
R353	1-247-903-00	CARBON 1M 5% 1/4W (D309:AEP, EE, CIS/D359:AEP, UK)	
R354	1-249-441-11	CARBON 100K 5% 1/4W (D309:AEP, EE, CIS/D359:AEP, UK)	
R355	1-249-433-11	CARBON 22K 5% 1/4W (D309:AEP, EE, CIS/D359:AEP, UK)	
R356	1-249-421-11	CARBON 2.2K 5% 1/4W (D309:AEP, EE, CIS/D359:AEP, UK)	
R361	1-249-437-11	CARBON 47K 5% 1/4W	
R362	1-249-437-11	CARBON 47K 5% 1/4W	
R363	1-249-425-11	CARBON 4.7K 5% 1/4W (D309:AEP, EE, CIS/D359:AEP, UK)	
R364	1-249-425-11	CARBON 4.7K 5% 1/4W (D309:AEP, EE, CIS/D359:AEP, UK)	
R365	1-249-429-11	CARBON 10K 5% 1/4W (D309:AEP, EE, CIS/D359:AEP, UK)	
R366	1-249-413-11	CARBON 470 5% 1/4W (D309:AEP, EE, CIS/D359:AEP, UK)	
R367	1-249-434-11	CARBON 27K 5% 1/4W (D309:AEP, EE, CIS/D359:AEP, UK)	
R368	1-249-433-11	CARBON 22K 5% 1/4W (D309:AEP, EE, CIS/D359:AEP, UK)	
R370	1-249-423-11	CARBON 3.3K 5% 1/4W (D309:G, IT/D359:IT)	
R501	1-249-417-11	CARBON 1K 5% 1/4W	
R502	1-249-417-11	CARBON 1K 5% 1/4W	
R503	1-249-417-11	CARBON 1K 5% 1/4W	
R504	1-249-417-11	CARBON 1K 5% 1/4W	
R505	1-249-429-11	CARBON 10K 5% 1/4W	
R506	1-249-417-11	CARBON 1K 5% 1/4W	
△R510	1-249-401-11	CARBON 47 5% 1/4W	
R511	1-249-429-11	CARBON 10K 5% 1/4W	
R512	1-249-425-11	CARBON 4.7K 5% 1/4W	
R513	1-249-417-11	CARBON 1K 5% 1/4W	
R514	1-249-429-11	CARBON 10K 5% 1/4W	
R515	1-249-417-11	CARBON 1K 5% 1/4W	
R521	1-249-423-11	CARBON 3.3K 5% 1/4W	
R522	1-249-425-11	CARBON 4.7K 5% 1/4W	
R523	1-249-414-11	CARBON 560 5% 1/4W	
R524	1-249-417-11	CARBON 1K 5% 1/4W	
R525	1-249-410-11	CARBON 270 5% 1/4W	
R526	1-249-421-11	CARBON 2.2K 5% 1/4W	
R527	1-249-425-11	CARBON 4.7K 5% 1/4W	
R528	1-249-425-11	CARBON 4.7K 5% 1/4W	
R529	1-249-405-11	CARBON 100 5% 1/4W	
R530	1-249-405-11	CARBON 100 5% 1/4W	

Ref. No.	Part No.	Description	Remark
R531	1-249-423-11	CARBON 3.3K 5% 1/4W (D309:AEP, EE, CIS/D359:AEP, UK)	
R532	1-249-433-11	CARBON 22K 5% 1/4W (D309:AEP, EE, CIS/D359:AEP, UK)	
R533	1-249-414-11	CARBON 560 5% 1/4W (D309:AEP, EE, CIS/D359:AEP, UK)	
R534	1-249-417-11	CARBON 1K 5% 1/4W (D309:AEP, EE, CIS/D359:AEP, UK)	
R535	1-249-410-11	CARBON 270 5% 1/4W (D309:AEP, EE, CIS/D359:AEP, UK)	
R536	1-249-421-11	CARBON 2.2K 5% 1/4W (D309:AEP, EE, CIS/D359:AEP, UK)	
R537	1-249-425-11	CARBON 4.7K 5% 1/4W (D309:AEP, EE, CIS/D359:AEP, UK)	
R538	1-249-405-11	CARBON 100 5% 1/4W (D309:AEP, EE, CIS/D359:AEP, UK)	
		< VARIABLE RESISTOR >	
RV301	1-238-601-11	RES, ADJ, CARBON 22K	
RV302	1-238-601-11	RES, ADJ, CARBON 22K	
		< TRASFORMER >	
T301	1-404-807-11	TRANSFORMER, DISCRIMINATOR	
T302	1-235-126-00	ENCAPSULATED COMPONENT (D309:G, IT/D359:IT)	
		< TERMINAL >	
TM301	1-537-264-11	TERMINAL BOARD (ANTENNA) (A37/D359:UK)	
* TM301	1-537-288-11	TERMINAL BOARD, ANTENNA (PAL) (ANTENNA) (D309/D359:AEP, IT)	
		< TEST PIN >	
* TP1	1-560-060-00	PIN, CONNECTOR 2P	
		< VIBRATOR >	
XT501	1-577-126-21	VIBRATOR, CRYSTAL (7.2MHz)	

*	1-646-974-21	SW BOARD (A37) *****	
		< SWITCH >	
△SW1	1-572-266-11	SWITCH, VOLTAGE SELECTION (VOLTAGE SELECTOR)	

The components identified by mark △ or dotted line with mark △ are critical for safety.
Replace only with part number specified.

REVISED

VOL

Ref.No.	Part No.	Description	Remark
*	1-646-978-11	VOL BOARD (D309) *****	
*	1-646-978-21	VOL BOARD (A37/D359) ***** < CAPACITOR >	
C413	1-164-159-11	CERAMIC 0.1uF 50V < VARIABLE RESISTOR >	
RV242	1-223-291-11	RES, VAR, CARBON 100K/100K (VOLUME)	

MISCELLANEOUS *****			
16	1-696-986-31	WIRE (FLAT TYPE) (7 CORE)	
17	1-575-666-11	WIRE, FLAT TYPE (11 CORE)	
18	1-751-025-11	WIRE (FLAT TYPE) (9 CORE) (A37, D359)	
	1-751-025-31	WIRE (FLAT TYPE) (9 CORE) (A37, D309, D359)	
* 52	1-533-213-11	HOLDER, FUSE (A37/D359)	
	1-533-217-31	HOLDER, FUSE (D309)	
△63	1-575-653-11	CORD, POWER (A37:E, PX)	
△64	1-690-608-11	CORD, POWER (A37:AUS)	
△65	1-696-570-21	CORD, POWER (D359:UK)	
△66	1-575-651-11	CORD, POWER	
△F801	1-532-078-00	FUSE (1A)	
△F802	1-532-078-00	FUSE (1A)	
△F803	1-532-299-00	FUSE (5A)	
△F804	1-532-299-00	FUSE (5A)	
△F805	1-532-286-00	FUSE (2.5A)	
△F806	1-532-286-00	FUSE (2.5A)	
FL431	1-519-648-21	INDICATOR TUBE, FLUORESCENT	
FL601	1-519-711-11	INDICATOR TUBE, FLUORESCENT	
△T1	1-423-646-21	TRANSFORMER, POWER (D359)	
△	1-423-646-31	TRANSFORMER, POWER (D309)	
△	1-423-647-21	TRANSFORMER, POWER (A37)	
△T2	1-423-499-11	TRANSFORMER, POWER (D309)	
△	1-423-499-21	TRANSFORMER, POWER (D359)	
△	1-423-500-21	TRANSFORMER, POWER (A37)	

Ref.No.	Part No.	Description	Remark
ACCESSORIES & PACKING MATERIALS *****			
	1-466-982-11	COMMANDER, STANDARD (RM-S309) (D309)	
	1-466-982-21	COMMANDER, STANDARD (RM-S309) (A37, D359)	
	1-501-369-11	ANTENNA (D359:AEP, IT)	
	1-501-374-11	ANTENNA, LOOP (D309:AEP, IT, EE, CIS/D359:AEP, IT)	
	1-501-536-11	ANTENNA (D309:AEP, IT, EE, CIS)	
	1-696-860-11	CORD, CONNECTION 13P (D309:AEP1, IT/D359:AEP1, IT)	
*	3-703-713-41	STICKER, SONY SYMBOL (10)	
	3-707-584-01	COVER, BATTERY (A37, D359)	
	3-707-584-21	COVER, BATTERY (D309)	
	3-756-332-11	MANUAL, INSTRUCTION (ENGLISH, FRENCH, SPANISH, PORTUGUESE) (D309:AEP)	
	3-756-332-41	MANUAL, INSTRUCTION (GERMAN, DUTCH, SWEDISH, ITALIAN) (D309:AEP, IT)	
	3-756-332-51	MANUAL, INSTRUCTION (GERMAN, DUTCH, SWEDISH, ITALIAN) (D359:IT)	
	3-756-334-41	MANUAL, INSTRUCTION (ENGLISH, FRENCH, SPANISH, PORTUGUESE) (D359:AEP)	
*	4-957-500-01	INDIVIDUAL CARTON (D309:AEP, IT)	
*	4-957-653-01	INDIVIDUAL CARTON (D309:EE, CIS)	
*	4-958-606-01	CUSHION (D309:AEP, IT, EE, CIS)	

***** HARDWARE LIST *****			
#1	7-685-646-79	SCREW +BVTP 3X8 TYPE2 N-S	
#2	7-682-560-04	SCREW +BVTT 4X6 (S) (A37, D309:AEP, G, IT, EE, CIS, D359)	
#3	7-685-871-01	SCREW +BVTT 3X6 (S)	

The components identified by mark △ or dotted line with mark △ are critical for safety. Replace only with part number specified.

STR-A37/D309/D359

SONY® SERVICE MANUAL

AEP Model
STR-D309/D359

UK Model
STR-D359

Australian Model

E Model

PX Model
STR-A37

SUPPLEMENT-1

File this Supplement with the Service Manual.



Subject : POLAR BOARD
(PRINTED WIRING BOARD)
(CIS Model)
: ELECTRICAL ADJUSTMENTS
~~Correction~~

[POLAR BOARD] (CIS model)

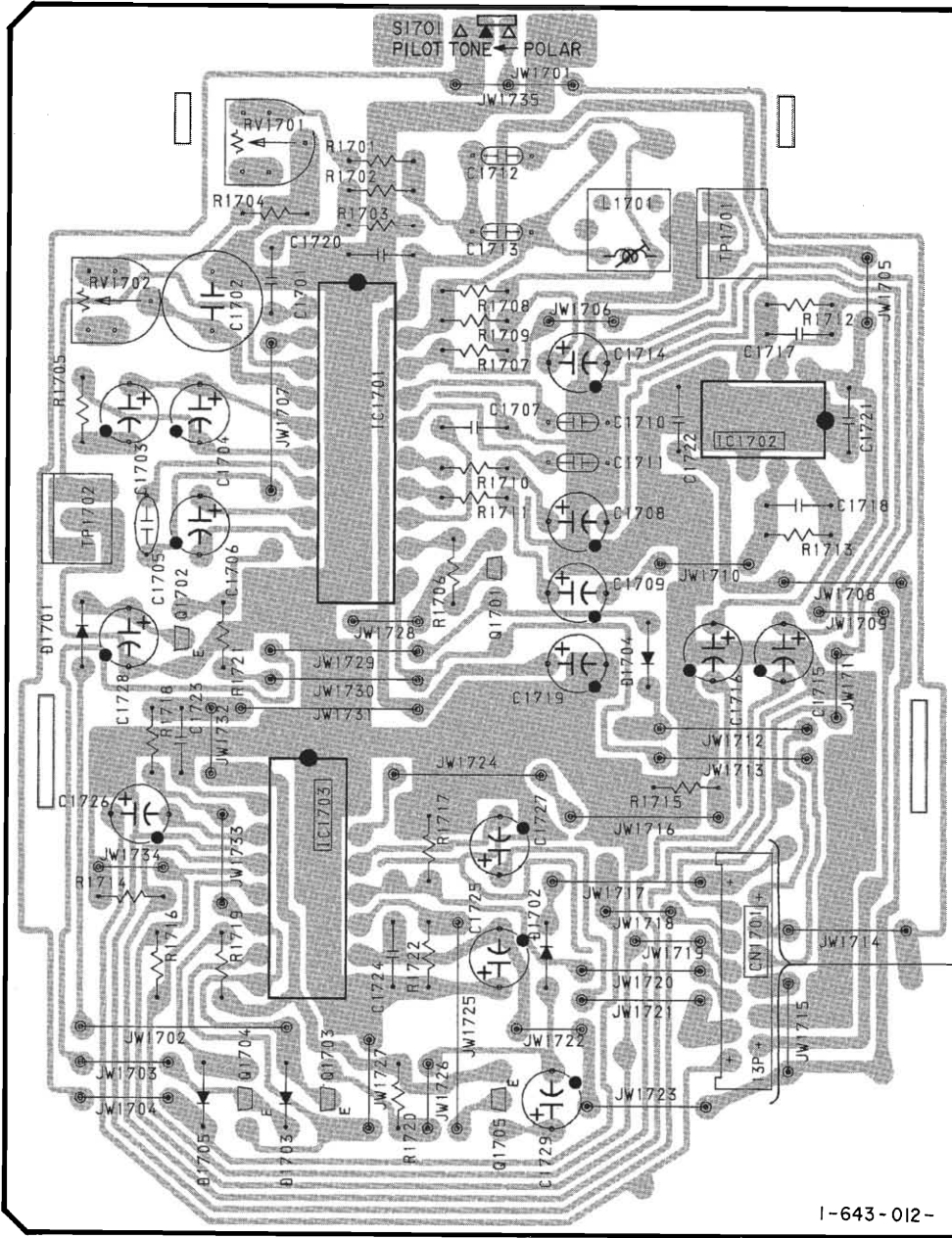

09

13

ST MAIN BOARD
CN301

(Refer to page 14 for Service Manual)

ELECTRICAL ADJUSTMENTS

SUBCARRIER ADJUSTMENT (CIS Model only)

SWITCH POSITION		Function Selector: Radio Band Selector: FM FM mode: Mono					
SIGNAL GENERATOR		69 MHz, 60 dB, FM modulated					
STEP	TEST STAGE	FM TUNING FREQUENCY	SIGNAL GENERATOR	ADJUSTMENT	REMARKS		
1	fo	69 MHz	1 kHz (10 kHz dev.)	L1701	The value in this state should be 0 dB (Vo).		
2						31.25 kHz (10 kHz dev.)	Adjust for maximal output.
3	Q					RV1701	Indication is +14 dB against Vo.

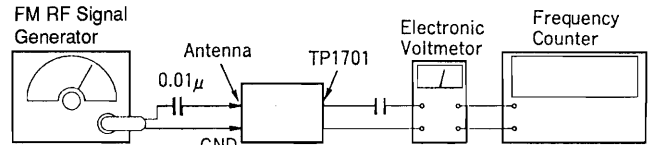

Fig. 1 SUBCARRIER

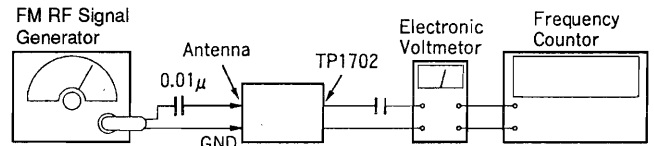
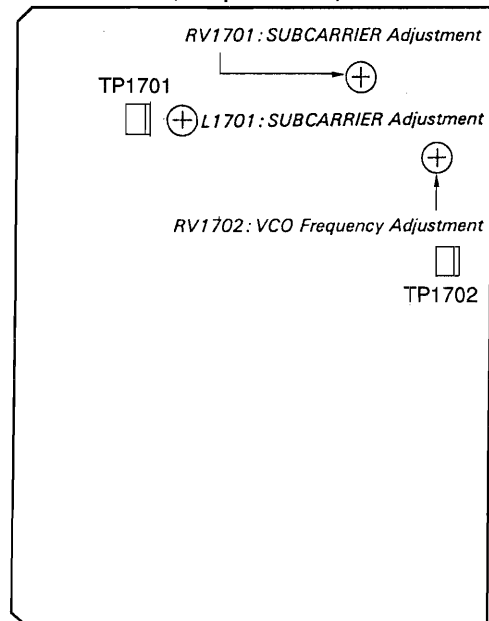

Fig. 2 VCO FREQUENCY

VCO FREQUENCY ADJUSTMENT

SIGNAL GENERATOR		1kHz, 30%, FM modulated (mono signal)		
FREQUENCY	FM TUNING FREQUENCY	ADJUSTMENT	REMARKS	
FM mono position		FM stereo position (unmodulated)		
69 MHz at 60 dB	69 MHz	RV1702	Adjust for 31.25 kHz ± 50 Hz.	

POLAR BOARD(Component side)



REVISED

• CORRECTION

SECTION 3 DIAGRAMS

3-10. SCHEMATIC DIAGRAM

• MAIN SECTION (STR-D309/D359) (Page 29)

: Indicates corrected portion.

AEP2 : AEP with POWER SOURCE

G : German model.

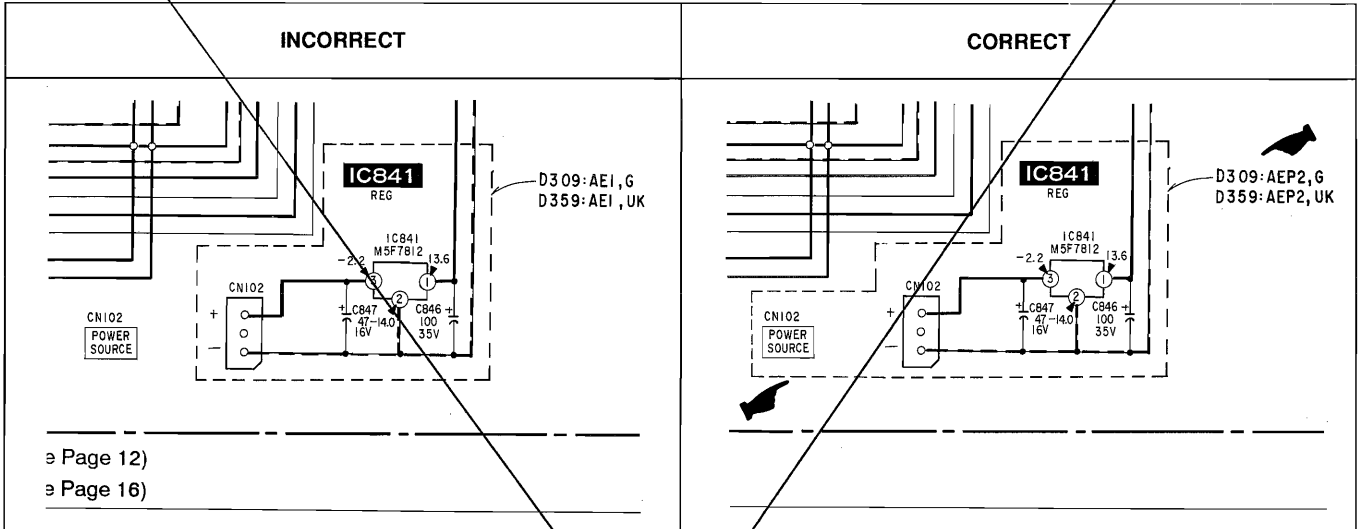

SECTION 4 EXPLODED VIEWS

4-2. CHASSIS SECTION (page 45)

: Indicates corrected portion.

G : German model.

IT : Italian model.

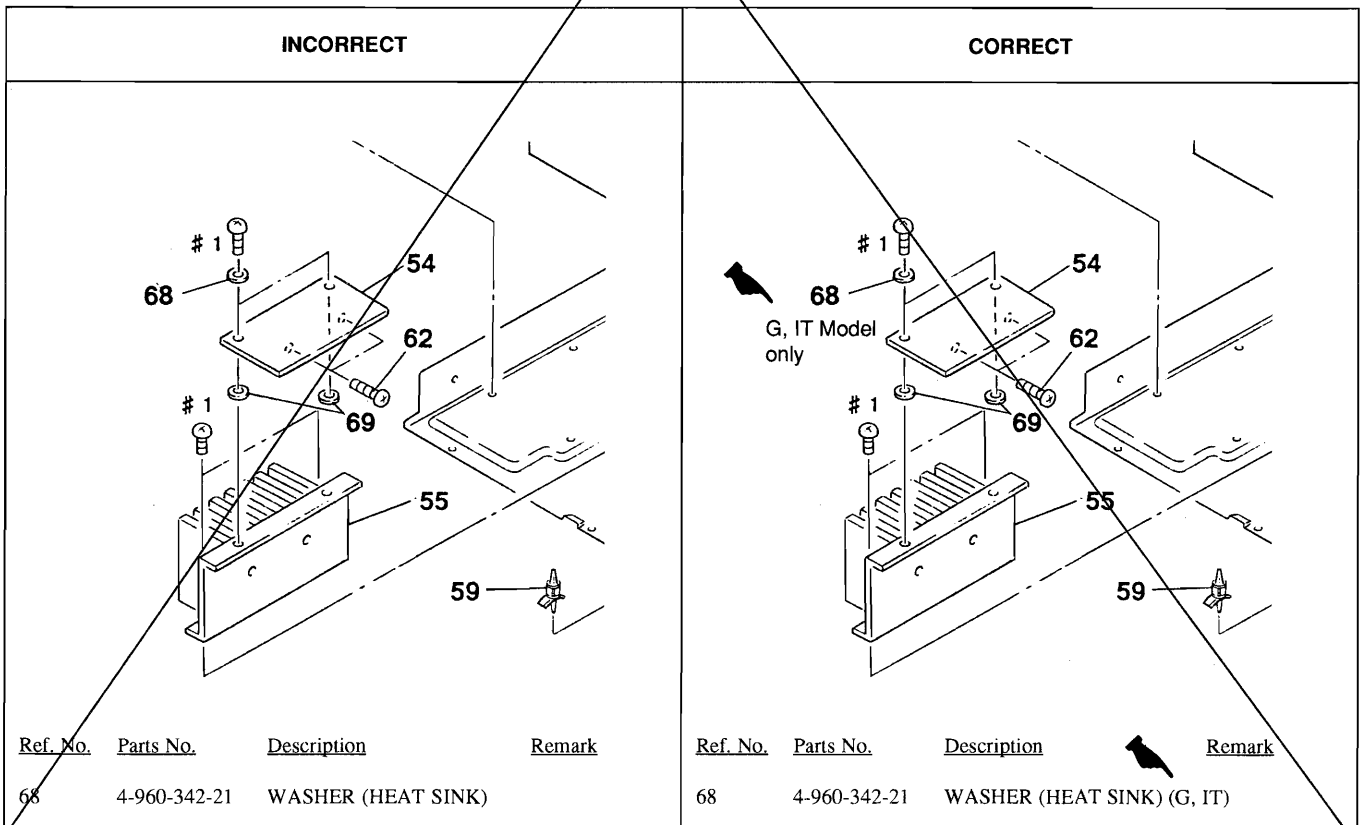

REVISED

SECTION 5 ELECTRICAL PARTS LIST

✶ : Indicated Corrected portion

AEP1: AEP with out POWER SOURCE
 AEP2: AEP with POWER SOURCE
 EE: East European model
 CIS: CIS model
 G: German model
 IT: Italian model

PAGE	INCORRECT				CORRECT			
	Ref. No.	Part No.	Description	Remark	Ref. No.	Part No.	Description	Remark
47	*	A-4356-904-A	MAIN BOARD, COMPLETE (D309:AEP)		*	A-4356-904-A	MAIN BOARD, COMPLETE (D309:AEP2)	
	*	A-4360-174-A	MAIN BOARD, COMPLETE (D309:EE, CIS)		*	A-4360-174-A	MAIN BOARD, COMPLETE (D309:AEP1, EE, CIS)	
	*	A-4356-985-A	MAIN BOARD, COMPLETE (D359:AEP)		*	A-4356-985-A	MAIN BOARD, COMPLETE (D359:AEP2)	
					*	A-4360-499-A	MAIN BOARD, COMPLETE (D359:AEP1)	
	< CAPACITOR >				< CAPACITOR >			
	C846	1-124-122-11	ELECT 100uF 20% 50V (D309:AEP, G/D359:AEP, UK)		C846	1-124-122-11	ELECT 100uF 20% 25V (D309:AEP2, G/D359:AEP2, UK)	
	C847	1-124-477-11	ELECT 47uF 20% 25V (D309:AEP, G/D359:AEP, UK)		C847	1-124-477-11	ELECT 47uF 20% 25V (D359:AEP2, UK)	
					C847	1-124-910-11	ELECT 47uF 20% 50V (D309:AEP2, G)	
48	< CONNECTOR >				< CONNECTOR >			
	* CN102	1-566-210-11	PIN, CONNECTOR 3P (POWER SOURCE) (D309:AEP, G/D359:AEP, UK)		* CN102	1-566-210-11	PIN, CONNECTOR 3P (POWER SOURCE) (D309:AEP2, G/D359:AEP2, UK)	
	< IC >				< IC >			
	IC841	8-759-604-39	IC AN6291 (D309:AEP, G/D359:AEP, UK)		IC841	8-759-604-39	IC AN6291 (D309:AEP2, G/D359:AEP2, UK)	
	< RESISTOR >				< RESISTOR >			
49	R733	1-249-436-11	CARBON 39K 5% 1/4W		R733	1-249-436-11	CARBON 39K 5% 1/4W (EXCEPT D359:AEP1)	
					R733	1-249-437-11	CARBON 47K 5% 1/4W (D359:AEP1)	
61	ACCESSORIES & PACKING MATERIALS *****				ACCESSORIES & PACKING MATERIALS *****			
		1-696-860-11	CORD, CONNECTION 13P (D309:AE2, IT, EE, CIS/D359:AE2, IT)			1-696-860-11	CORD, CONNECTION 13P (D309:AEP1, IT/D359:AEP1, IT)	

