

# STR-D360Z/DE315/DE415

## SERVICE MANUAL

*US Model*  
*Canadian Model*  
 STR-D360Z/DE315/DE415  
*Australian Model*  
 STR-DE315/DE415  
*E Model*  
*Chinese Model*  
 STR-DE315



Photo : STR-DE315 model

Manufactured under license from Dolby Laboratories Licensing Corporation.  
 "DOLBY" and the double-D symbol  $\square$  are trademarks of Dolby Laboratories Licensing Corporation.

### SPECIFICATIONS

#### Audio power specifications (US only)

#### POWER OUTPUT AND TOTAL HARMONIC DISTORTION

With 8-ohm load, both channels driven, from 20 - 20,000 Hz, rated 100 watts (STR-DE415/D360Z), or 60 watts (STR-D315) per channel minimum RMS power, with no more than 0.09 % total harmonic distortion from 250 milliwatts to rated output.

#### Amplifier section

**Stereo mode** (8 ohms at 20 Hz, 20 kHz less than 0.09% total harmonic distortion)  
 100W + 100W (STR-DE415/D360Z)  
 60W + 60W (STR-DE315)

**Surround mode** (8 ohms at 1 kHz, THD 0.8%)  
**Front:**  
 STR-DE415 /D360Z: 100 W/ch  
 STR-DE315: 60 W/ch  
**Center: (Pro Logic Mode)**  
 STR-DE415 /D360Z: 100 W  
 STR-DE315: 60 W  
**Rear:**  
 STR-DE415 /D360Z: 100 W  
 STR-DE315: 60 W

**5.1/DVD\* mode** (8 ohm at 1 KHz, THD 0.8%)  
**Front:** 100W/ch  
**Center:** 100W/ch  
**Rear:** 50W/ch

**Dynamic power output** 8 ohms:  
 STR-DE415 /D360Z: 145 W + 145 W  
 STR-DE315: 100 W + 100 W

4 ohms:  
 STR-DE415 /D360Z: 190 W + 190 W  
 STR-DE315: 145 W + 145 W

**Frequency response** PHONO\*\* : RIAA equalization curve  $\pm 0.5$  dB  
 TV/DBS, CD, TAPE/MD, VIDEO, 5.1/DVD\*  
 10 Hz - 50 kHz  $\pm 1$  dB

Inputs	Sensitivity	Impedance	S/N (weighting network, input level)
PHONO** (MM)	2.5 mV	50 kilohms	74 dB 72 dB* (A, 2.5 mV)
CD, 5.1/DVD*	200 mV		
TAPE/MD, TV/DBS, VIDEO	150 mV	50 kilohms	82 dB 82 dB* (A, 150 mV)

\* 78 THF

**Outputs** TAPE/MD REC OUT: Voltage 150 mV, Impedance 10 kilohms  
 VIDEO AUDIO OUT: Voltage 150 mV, Impedance 10 kilohms  
 PHONES: Accepts low and high impedance headphones

**Muting** Full mute

**BASS BOOST** +10 dB at 70 Hz

**TONE**  $\pm 8$  dB at 100 Hz and 10 kHz

#### FM tuner section

**Tuning range** 87.5 - 108.0 MHz

**Antenna terminals** 75 ohms, unbalanced  
 300 ohms, balanced (US, Canadian model)  
 75 ohms, unbalanced (EXCEPT model)

**Sensitivity** Mono: 18.3 dBf, 4.5  $\mu$ V  
 Stereo: 38.3 dBf, 45  $\mu$ V

**Usable sensitivity** 11.2 dBf, 2  $\mu$ V (IHF)

**S/N** Mono: 76 dB  
 Stereo: 70 dB

**Harmonic distortion at** Mono: 0.3 %  
 Stereo: 0.5 %

**1 KHz Separation** 45 dB at 1 kHz

**Frequency response** 30 Hz - 15 kHz,  $-45$  dB

**Selectivity** 60 dB at 400 kHz

#### AM tuner section

**Tuning range** US, Canadian MODEL: 530 - 1710 kHz (10kHz STEP)  
 Australian, Singapore, Malaysia, Chinese MODEL: 531 - 1602 kHz (9 kHz STEP)  
 E, PX, Saudi Arabia MODEL: 531-1602kHz (9kHz STEP)  
 530-1620kHz (10kHz STEP)

— Continued on next page —

## FM STEREO/FM-AM RECEIVER



# SONY®

## TABLE OF CONTENTS

<b>Antenna</b>	Loop antenna
<b>Usable sensitivity</b>	50 dB/m (at 1,000 kHz or 999 kHz)
<b>S/N</b>	54 dB (at 50 mV/m)
<b>Harmonic distortion</b>	0.5 % (50 mV/m, 400 Hz)
<b>Selectivity</b>	At 9 kHz: 35 dB At 10 kHz: 40 dB
<b>Video section</b>	
<b>Inputs</b>	VIDEO, TV/DBS, 5.1/DVD*: 1 Vp-p 75 ohms
<b>Outputs</b>	VIDEO: 1 Vp-p 75 ohms MONITOR: 1 Vp-p 75 ohms
<b>General System</b>	Tuner section: PLL quartz-locked digital synthesizer system Pre-amplifier section: Low-noise NF type equalizer Power amplifier section: Pure-complimentary SFP
<b>Power requirements</b>	US, Canadian : 120 V AC, 60 Hz  E, Saudi Arabia, PX : 120/220/240V AC, 50/60Hz  Australian : 240 V AC, 50/60 Hz  Singapore, Malaysia, Chinese : 230V AC, 50/60Hz
<b>Power consumption</b>	STR-DE415/D360Z (US): 190 W STR-D315 (US): 150 W
<b>AC outlets</b>	US, Canadian : 1 switched, total 120 W/1A Max  EXCEPT: 1 switched, total 100 W
<b>Dimensions</b>	17 x 5 <sup>7</sup> / <sub>8</sub> x 11 <sup>5</sup> / <sub>8</sub> inches (430 x 148 x 295 mm)
<b>Mass (Approx.)</b>	6.5 kg (14 lb 5 oz)
<b>Supplied accessories</b>	FM wire antenna (1) AM loop antenna (1) Remote controller (remote) (1) Size AA (R6) batteries (2)

Specifications .....	1
----------------------	---

### 1. GENERAL

Location and Function of controls .....	4
---	---

### 2. EXPLANATION OF IC TERMINALS .....

### 3. DIAGRAMS

3-1. Circuit Boards Location .....	7
3-2. Printed Wiring Boards (MAIN SECTION) .....	9
3-3. Schematic Diagram (MAIN SECTION) .....	13
3-4. Schematic Diagram (DISPLAY SECTION) .....	18
3-5. Printed Wiring Boards (DISPLAY SECTION) .....	21

### 4. EXPLODED VIEWS

4-1. Front Panel Section .....	25
4-2. Chassis Section .....	27

### 5. ELECTRICAL PARTS LIST .....

\* 5.1/DVD is for STR-DE515/D460Z only.  
\*\* except STR-DE315 (US, Canadian)  
Design and specifications are subject to change without notice.

### SAFETY CHECK-OUT

After correcting the original service problem, perform the following safety checks before releasing the set to the customer. Check the antenna terminals, metal trim, "metalized" knobs, screws, and all other exposed metal parts for AC leakage. Check leakage as described below.

#### LEAKAGE

The AC leakage from any exposed metal part to earth ground and from all exposed metal parts to any exposed metal part having a return to chassis, must not exceed 0.5 mA, (500 microampere). Leakage current can be measured by any one of three methods.

1. A commercial leakage tester, such as the Simpson 229 or RCA WFC60A, follow the manufacturer's instructions to use these instruments.
2. A battery-operated AC milliammeter. The Data Precision 345 digital multimeter is suitable for this job.

3. Measuring the voltage drop across a resistor by means of a VOM or battery-operated AC voltmeter. The "lim" indication is 0.75 V; an analog meter must have an accurate low-voltage scale. The Simpson 220 and Sawa SH-63 Tri are examples of a positive VOM that is suitable. Nearly all battery operated digital multimeters that have a 2V AC range are suitable. (See Fig. A)

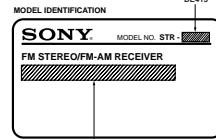
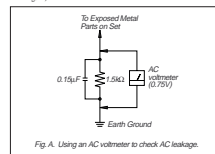

US, Canadian model : AC 120V 60Hz  
 Australian model : AC 240V -50/60Hz  
 Singapore, Malaysia : AC 120, 220, 240V selectable -50/60Hz  
 Chinese model : AC 230V -50/60Hz

#### SAFETY-RELATED COMPONENT WARNING!

COMPONENTS IDENTIFIED BY MARK A OR DOTTED LINE WITH MARK Δ ON THE SCHEMATIC DIAGRAMS AND IN THE PARTS LIST ARE CRITICAL TO SAFE OPERATION. REPLACE THESE COMPONENTS WITH SONY PARTS WHOSE PART NUMBERS APPEAR AS SHOWN IN THIS MANUAL OR IN SUPPLEMENTS PUBLISHED BY SONY.

#### ATTENTION AU COMPOSANT AYANT RAPPORT A LA SÉCURITÉ

LES COMPOSANTS IDENTIFIÉS PAR UNE MARQUE Δ SUR LES DIAGRAMMES SCHEMATIQUES ET LA LISTE DES PIÈCES SONT CRITIQUES POUR LA SÉCURITÉ DE FONCTIONNEMENT. NE REMPLACEZ CES COMPOSANTS QUE PAR DES PIÈCES SONY DONT LES NUMÉROS SONT DONNÉS DANS CE MANUEL OU DANS LES SUPPLÉMENTS PUBLIÉS PAR SONY.

### SECTION 1 GENERAL

#### LOCATION AND FUNCTION OF CONTROLS

STR-DE115/119/120

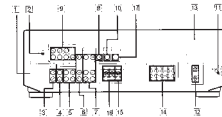

- |                      |                                       |                                       |
|----------------------|---------------------------------------|---------------------------------------|
| 1 ANTENNA (AM/FM)    | 9 S.I. (TUN) Audio System             | 18 SWITCHED SL. OUTLET                |
| 2 20 ground terminal | 10 S.I. (TUN) (S.I. (TUN) (S.I. (TUN) | 19 S.I. (TUN) (S.I. (TUN) (S.I. (TUN) |
| 3 TUNING             | 11 MUTE (MUTE) (MUTE) (MUTE)          | 20 S.I. (TUN) (S.I. (TUN) (S.I. (TUN) |
| 4 LED                | 12 MUTE (MUTE) (MUTE) (MUTE)          | 21 S.I. (TUN) (S.I. (TUN) (S.I. (TUN) |
| 5 TUNING             | 13 MUTE (MUTE) (MUTE) (MUTE)          | 22 S.I. (TUN) (S.I. (TUN) (S.I. (TUN) |
| 6 TUNING             | 14 MUTE (MUTE) (MUTE) (MUTE)          | 23 S.I. (TUN) (S.I. (TUN) (S.I. (TUN) |
| 7 MUTE (MUTE)        | 15 MUTE (MUTE) (MUTE) (MUTE)          | 24 S.I. (TUN) (S.I. (TUN) (S.I. (TUN) |
| 8 MUTE (MUTE)        | 16 MUTE (MUTE) (MUTE) (MUTE)          | 25 S.I. (TUN) (S.I. (TUN) (S.I. (TUN) |

STR-DE115

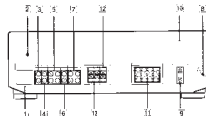

- |                      |                |                                       |
|----------------------|----------------|---------------------------------------|
| 1 ANTENNA (AM/FM)    | 4 TUNING       | 11 SWITCH (S.I. (TUN) (S.I. (TUN)     |
| 2 20 ground terminal | 5 MUTE (MUTE)  | 12 S.I. (TUN) (S.I. (TUN) (S.I. (TUN) |
| 3 TUNING             | 6 TUNING       | 13 MUTE (MUTE) (MUTE) (MUTE)          |
| 4 LED                | 7 MUTE (MUTE)  | 14 MUTE (MUTE) (MUTE) (MUTE)          |
| 5 TUNING             | 8 MUTE (MUTE)  | 15 MUTE (MUTE) (MUTE) (MUTE)          |
| 6 TUNING             | 9 MUTE (MUTE)  | 16 MUTE (MUTE) (MUTE) (MUTE)          |
| 7 MUTE (MUTE)        | 10 MUTE (MUTE) | 17 MUTE (MUTE) (MUTE) (MUTE)          |
| 8 MUTE (MUTE)        | 11 MUTE (MUTE) | 18 MUTE (MUTE) (MUTE) (MUTE)          |
| 9 MUTE (MUTE)        | 12 MUTE (MUTE) | 19 MUTE (MUTE) (MUTE) (MUTE)          |
| 10 MUTE (MUTE)       | 13 MUTE (MUTE) | 20 MUTE (MUTE) (MUTE) (MUTE)          |

### SECTION 2 EXPLANATION OF IC TERMINALS

Pin No.	Pin Name	IO	Description
1	DI02	O	
2	DI06	O	
3	DI05	O	
4	DI04	O	Fluorescent indicator tube drive.
5	DI03	O	
6	DI02	O	
7	DI01	O	
8	V <sub>CC</sub>	—	Power supply (+5V)
9	CLK	I	System clock.
10	S <sub>1</sub> DATA	I	System data.
11	PL1 DATA	I	PL1 data input from TU001.
12	S <sub>2</sub> CE (L47280)	O	Chip enable output.
13	CE (L47280)	O	Chip enable output.
14	REARRY	—	Not used.
15	BRIDGE CABLE	—	Not used (Open)
16	PROTECT	I	Protector detect input.
17	RESET	I	System reset terminal.
18	AUTO STOP	I	Auto stop detect input.
19	STEREO IN	I	Stereo detect input.
20	AV <sub>IN</sub>	—	Ground.
21	SPK SW	O	Speaker relay drive.
22	SUB-REV	O	Subcarrier relay.
23	POWER-REV	O	Power relay drive.
24	Not used	—	Not used.
25	SIGNAL	I	A/D signal input terminal.
26	A/D1	I	A/D1 key input terminal.
27	A/D2	I	A/D2 key input terminal.
28	A/D3	I	A/D3 key input terminal.
29	AV <sub>DET</sub>	—	Power supply (+5V)
30	AV REF	—	Reference voltage (+5V)
31	GND	—	Ground.
32	NC	—	Not used (Open)
33	Not	—	Ground.
34	X1	—	System clock (4.194MHz)
35	X2	—	System clock (4.194MHz)
36	IC MUTE	O	Main drive output for pFD2581V (IC701)
37	PRE-LOGIC	O	Prelogic LED.
38	STUDIO	O	CINEMA STUDIO LED.
39	HALL	O	HALL LED.
40	T MUTE	O	Tone mute drive output.

Pin No.	Pin Name	IO	Description
41	VOLUME UP	O	Volume up.
42	VOLUME DOWN	O	Volume down.
43	STANDBY	O	Standby LED drive.
44	SVT POWER	I	System power ON/OFF.
45	RDS DATA IN	I	RDS data input (AEP-10 MY, CH model)
46	RDS CLK IN	I	RDS clock input (AEP-10 MY, CH model)
47	STOP	I	Stop signal input from NM2101D (IC700)
48	V <sub>cc</sub>	—	Ground.
49	SRVCE	I	Service input.
50	POWER SW	I	Power switch input terminal.
51	S.tub.LED	—	Not used.
52	+5V	—	Power supply (+5V)
53	BACK BROWSE	—	Back browse LED drive.
54	PULSE MUTE	O	Line mute drive.
55	SL MUTE	—	Not used.
56	VERSION	I	Input for model select.
57	K14	I	Key in 4.
58	K13	I	Key in 3.
59	K12	I	Key in 2.
60	K11	I	Key in 1.
61	SR MUTE	—	Not used.
62	S15	O	Key out 1.
63	S14	O	Key out 2.
64	S13	O	Key out 3.
65	S12	O	Key out 4.
66	S11	O	
67	S10	O	
68	S9	O	
69	S8	O	
70	S7	O	Fluorescent indicator tube drive.
71	VLOAD	—	Connect to -24V.
72	S6	O	
73	S5	O	
74	S4	O	
75	S3	O	
76	S2	O	
77	S1	O	
78	DI010	O	
79	DI09	O	Fluorescent indicator tube drive.
80	DI08	O	

### SECTION 3 DIAGRAMS

#### 3-1. CIRCUIT BOARDS LOCATION

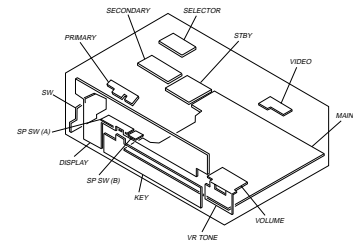

3-2. PRINTED WIRING BOARDS (MAIN SECTION)

• Semiconductor Location

Ref. No.	Location	Ref. No.	Location
D610	C-7	Q303	H-2
D710	J-12	Q304	G-2
D721	H-6	Q307	G-2
D722	H-6	Q308	H-2
D723	I-6	Q601	D-8
D724	H-6	Q602	C-9
D725	I-6	Q603	D-9
D801	I-7	Q604	C-9
D802	F-13	Q610	C-7
D804	J-7	Q620	D-8
D810	C-13	Q651	G-8
D811	C-13	Q652	G-9
D812	C-13	Q653	H-9
D813	C-13	Q654	G-9
D814	C-13	Q670	G-8
D815	C-13	Q701	I-8
D816	D-21	Q702	I-9
D817	F-7	Q703	J-9
D818	D-13	Q704	I-9
D820	D-13	Q710	J-12
D821	D-13	Q720	H-8
D822	D-12	Q721	H-6
D823	D-13	Q722	H-6
D901	J-13	Q723	I-6
		Q751	F-8
IC251	L-19	Q752	E-9
IC300	H-4	Q753	F-9
IC301	G-4	Q754	E-9
IC302	G-3	Q770	E-8
IC401	D-4	Q801	I-7
IC402	C-3	Q802	C-14
IC701	H-7	Q808	F-6
IC702	E-7	Q809	E-13
IC801	E-6	Q951	C-11
IC802	E-6		
IC950	B-11		

Note:

- : Parts extracted from the component side.
- : Pattern on the side which is seen.
- Abbreviation
  - SP : Singapore
  - MY : Malaysia
  - AUS : Australian
  - CND : Canadian
  - CH : Chinese

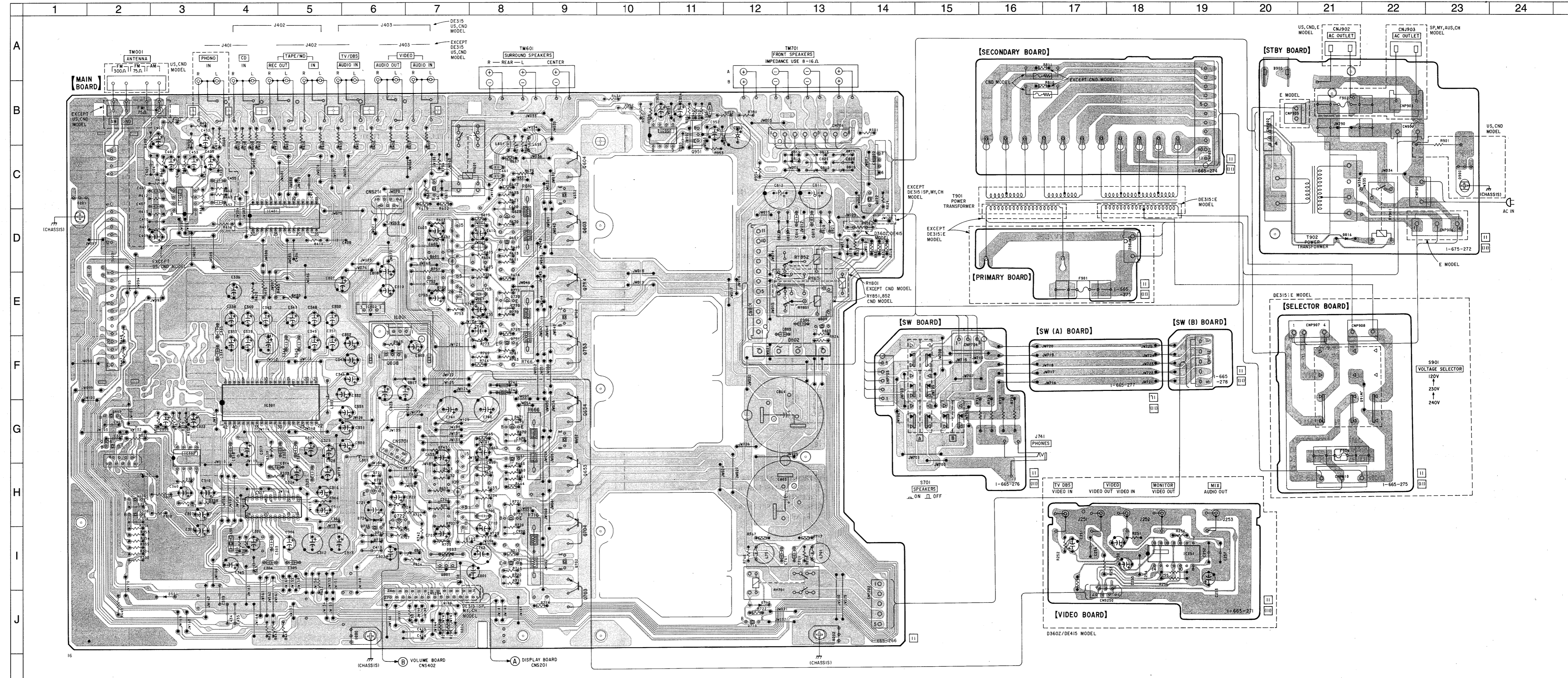

3-3. SCHEMATIC DIAGRAM (MAIN SECTION)

• Refer to page 17 for IC Block Diagrams.

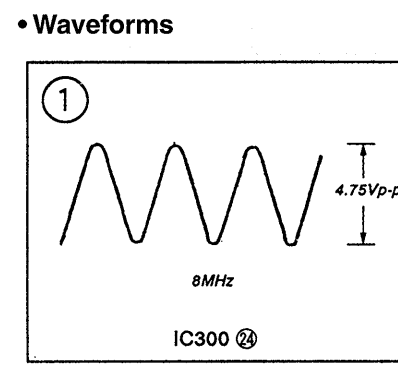
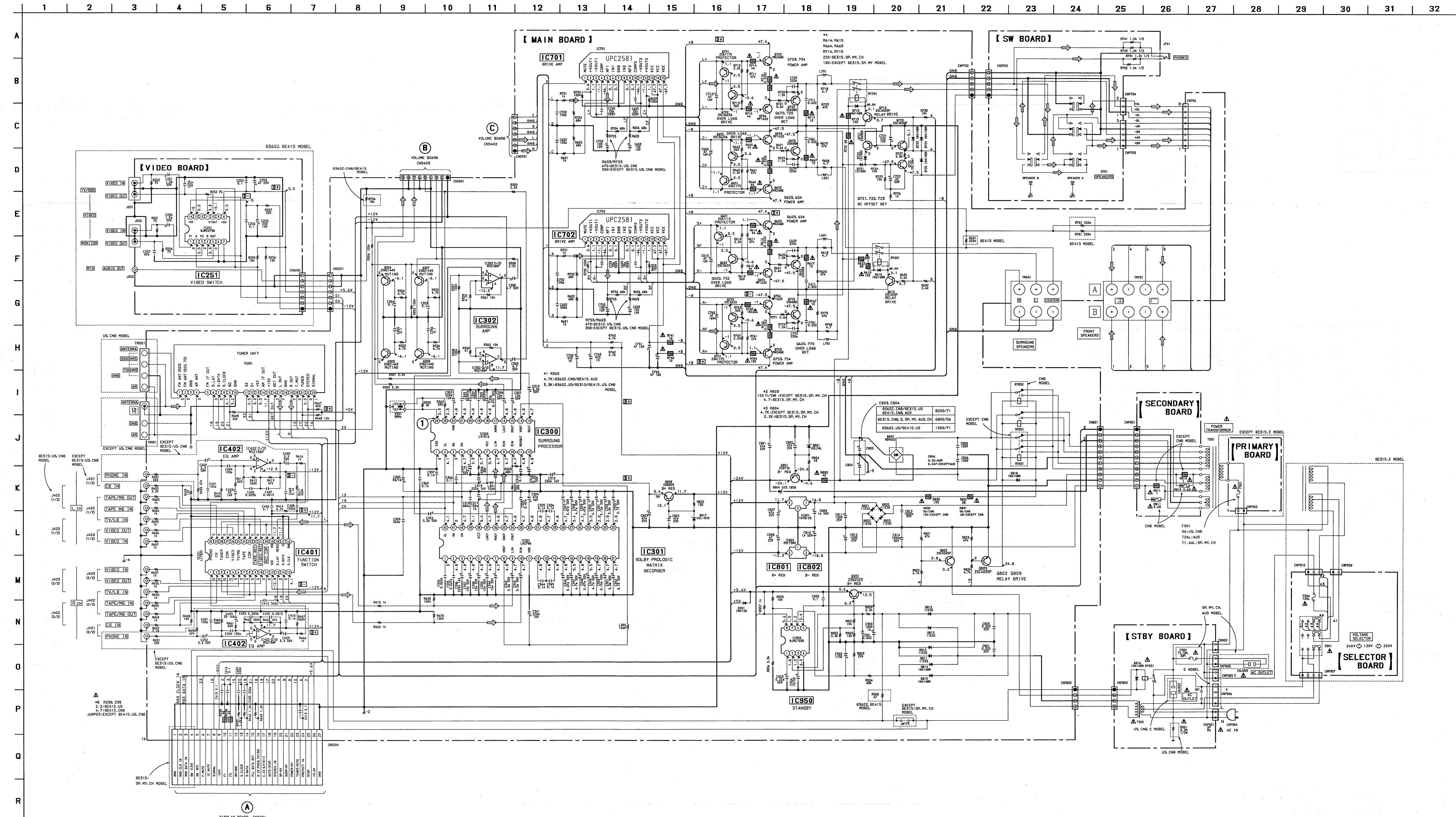

**Note:**

- All capacitors are in  $\mu\text{F}$  unless otherwise noted.  $\mu\text{F}$ :  $\mu\text{F}$  50VW or less are not indicated except for electrolytics and tantalums.
- All resistors are in  $\Omega$  and 1/4W or less unless otherwise specified.
- $\Delta$ : Internal component.
- B+**: B+ Line.
- B-**: B- Line.
- Voltagess and waveforms are dc with respect to ground under no-signal (detuned) conditions.
- No mark: FM
- ( ): AM
- Voltagess are taken with a VOM (Input impedance 10M $\Omega$ ). Voltage variations may be noted due to normal production tolerances.
- Waveforms are taken with an oscilloscope. Voltage variations may be noted due to normal production tolerances.
- Circled numbers refer to waveforms.
- Signal path.
- $\rightarrow$ : FM
- Abbreviation
- SP : Singapore
- MY : Malaysia
- AUS : Australian
- CND : Canadian
- CH : Chinese

**Note:**  
The components identified by mark  $\Delta$  or dotted line with mark  $\Delta$  are critical for safety. Replace only with part number specified.

**Note:**  
Les composants identifiés par une marque  $\Delta$  sont critiques pour la sécurité. Ne les remplacer que par une pièce portant le numéro spécifique.

• IC BLOCK DIAGRAMS — MAIN SECTION —

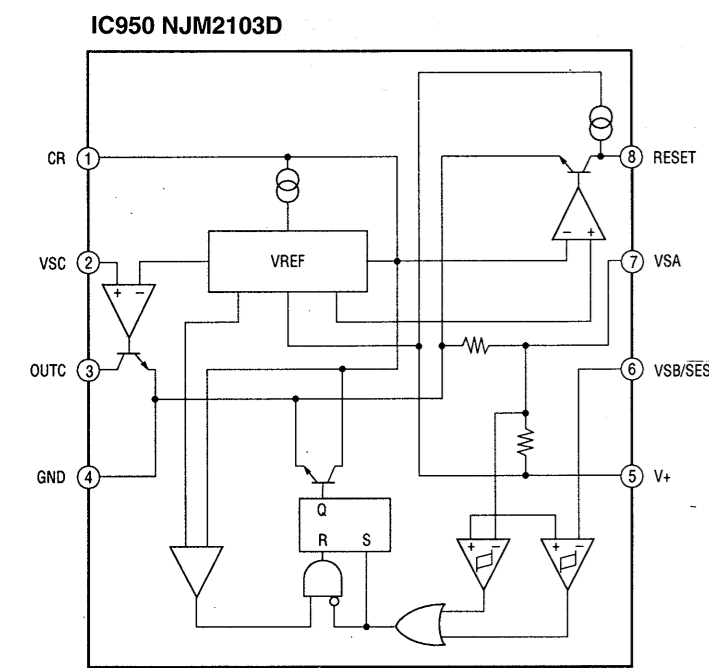
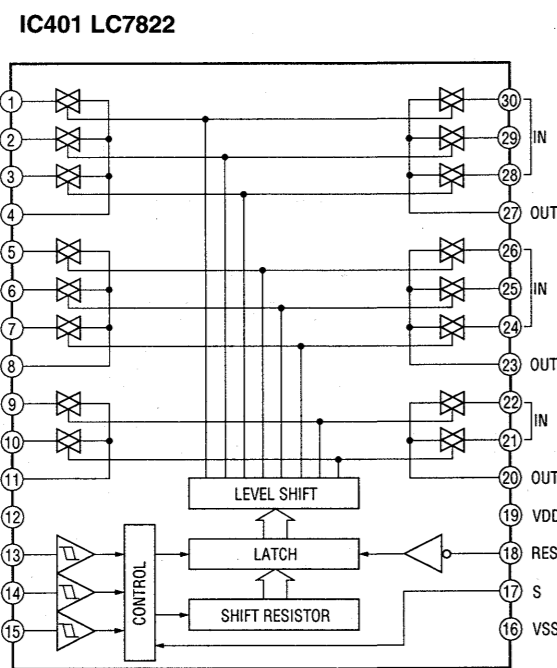
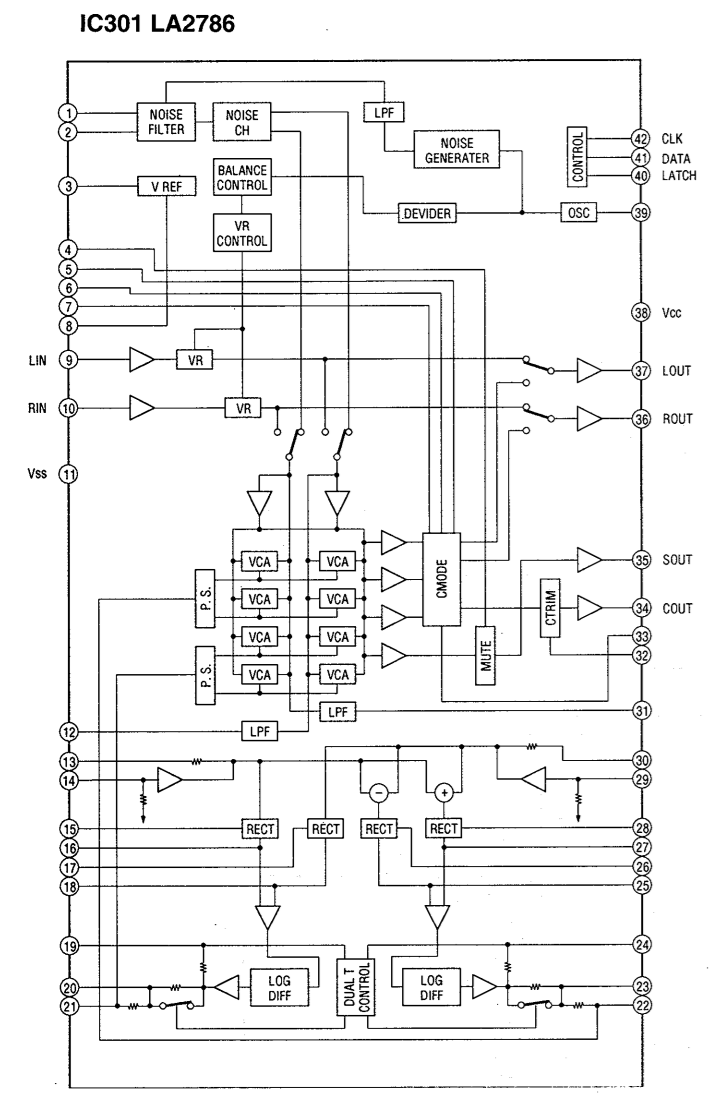
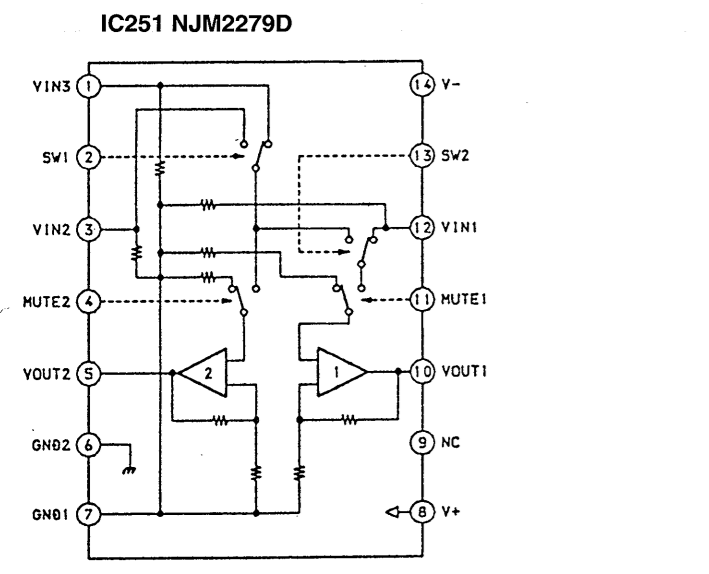

• Waveforms

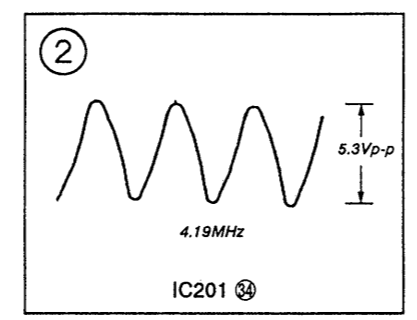

• IC BLOCK DIAGRAM — DISPLAY SECTION —

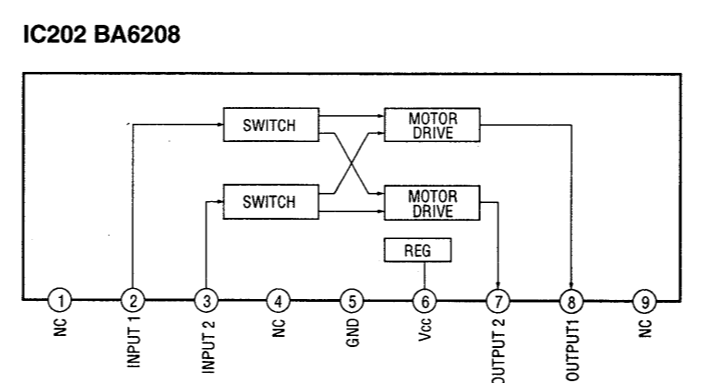

- Note:**
- All capacitors are in  $\mu\text{F}$  unless otherwise noted.  $\mu\text{F}$ :  $\mu\text{F}$  50WV or less are not indicated except for electrolytics and tantalums.
  - All resistors are in  $\Omega$  and 1/4W or less unless otherwise specified.
  - A: Internal component.
  - [B-]: B+ Line.
  - [B-]: B- Line.
  - ⊙: Voltages and waveforms are dc with respect to ground under no-signal conditions.
  - No mark: FM

- Voltages are taken with a VOM (Input impedance 10M $\Omega$ ). Voltage variations may be noted due to normal production tolerances.
- Waveforms are taken with an oscilloscope. Voltage variations may be noted due to normal production tolerances.
- Circled numbers refer to waveforms.
- Signal path.
- ⊙: FM

- Abbreviation
- SP: Singapore
- MY: Malaysia
- AUS: Australian
- CND: Canadian
- CH: Chinese

3-4. SCHEMATIC DIAGRAM (DISPLAY SECTION)

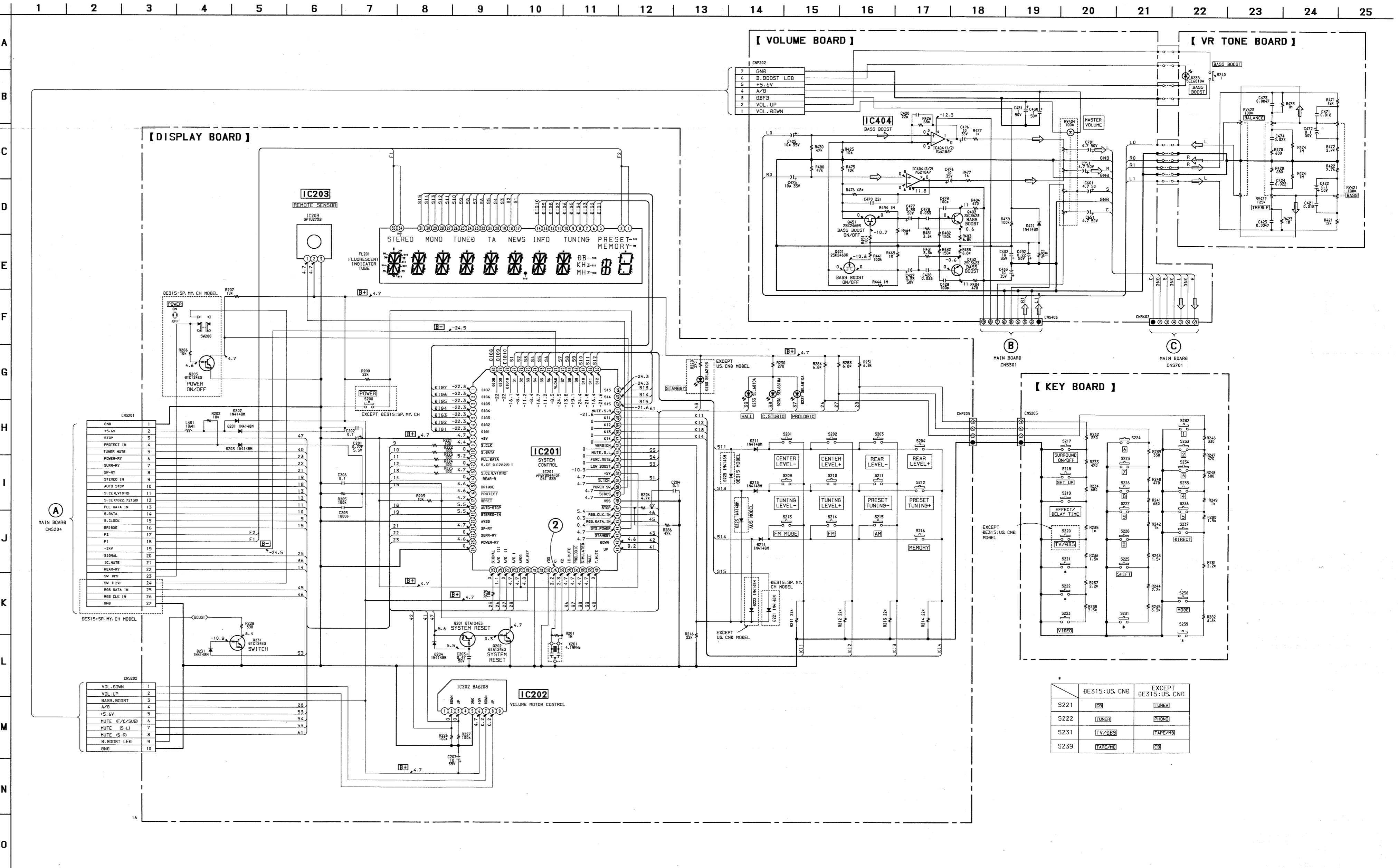

MAIN BOARD CN524

1	GND
2	+5.0V
3	STOP
4	TUNER MUTE
5	POWER-REY
6	SURR-RY
7	SP-RY
8	STEREO IN
9	AUTO STOP
10	S-CLK (1/2)
11	S-CLK (1/2)
12	S-CLK (1/2)
13	PLL DATA IN
14	S-DATA
15	S-CLOCK
16	BR180E
17	F2
18	-24V
19	SIGNAL
20	IC-MUTE
21	REAR-RY
22	SW-REV
23	SW-REV
24	SW-D20
25	RES DATA IN
26	RES CLK IN
27	GND

MAIN BOARD CN529

1	VOL. DOWN
2	VOL. UP
3	BASS BOOST
4	A/B
5	+5.0V
6	MUTE F/C/SUB
7	MUTE IS-LI
8	MUTE IS-R
9	B. BOOST LEB
10	GND

	BE315-US. CND	EXCEPT BE315-US. CND
S221	[CD]	[TURK]
S222	[TUNER]	[PHONO]
S231	[TV/VIDEO]	[TAPK2RD]
S239	[TAPE2RD]	[CD]

3-5. PRINTED WIRING BOARDS (DISPLAY SECTION)

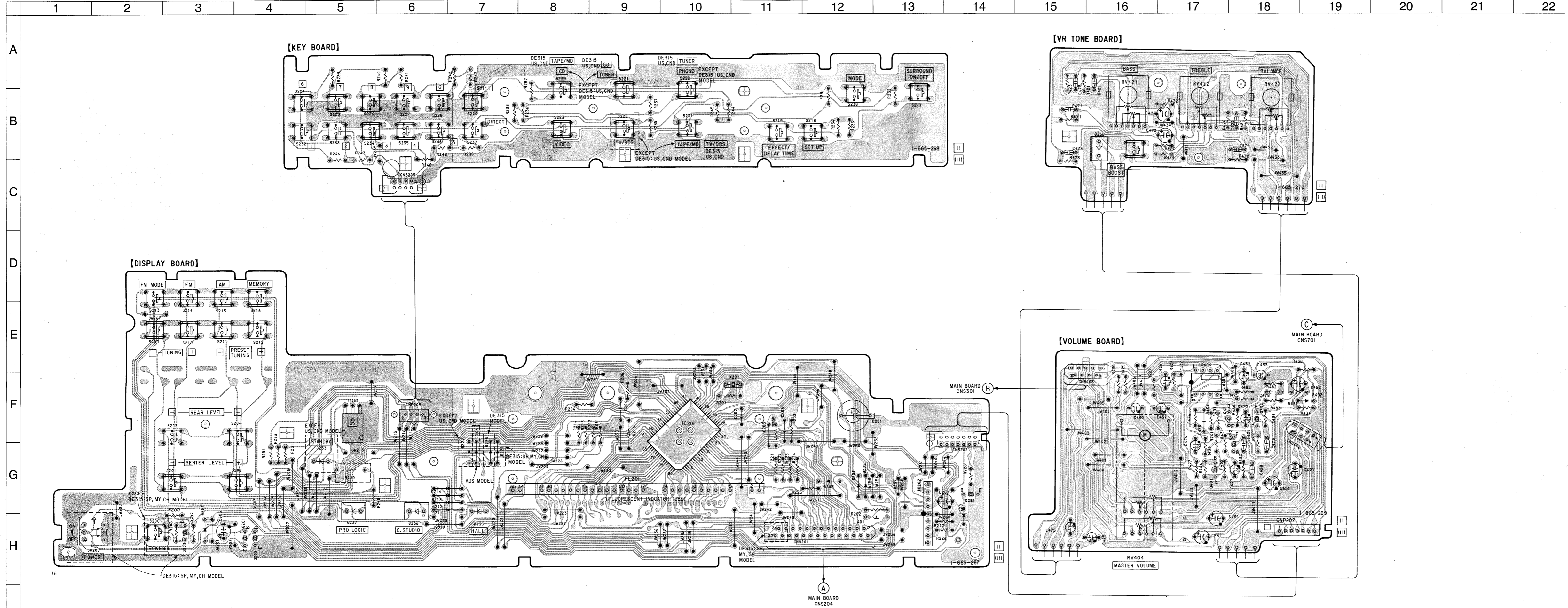

**• Semiconductor Location**

Ref. No.	Location	Ref. No.	Location
D201	G-12	D238	B-16
D202	G-12	D421	F-18
D203	G-12		
D204	G-3	IC201	F-10
D211	G-6	IC202	G-13
D212	G-6	IC203	F-5
D213	G-6	IC404	E-17
D214	G-6		
D221	G-7	Q201	H-4
D222	G-7	Q202	H-4
D223	F-9	Q203	H-3
D225	H-7	Q231	G-13
D231	G-13	Q401	G-7
D233	G-5	Q402	F-18
D235	G-7	Q451	F-17
D236	H-6	Q452	F-18
D237	H-5		

**Note:**  
 • — : Parts extracted from the component side.  
 • — : Pattern on the side which is seen.  
 • Abbreviation  
 SP : Singapore  
 MY : Malaysia  
 AUS : Australian  
 CND : Canadian  
 CH : Chinese

## SECTION 4 EXPLODED VIEWS

### NOTE:

- XX, -X mean standardized parts, so they may have some differences from the original one.
- Items marked "\*" are not stocked since they are seldom required for routine service. Some delay should be anticipated when ordering these items.
- The mechanical parts with no reference number in the exploded views are not supplied.
- Hardware (#mark) list is given in the last of this parts list.
- Abbreviation  
SP : Singapore    AUS : Australian  
CH : Chinese      CND : Canadian  
MY : Malaysia

The components identified by mark  $\Delta$  or dotted line with mark  $\Delta$  are critical for safety. Replace only with part number specified.

Les composants identifiés par une marque  $\Delta$  sont critiques pour la sécurité. Ne les remplacer que par une pièce portant le numéro spécifique.

### 4-1. FRONT PANEL SECTION

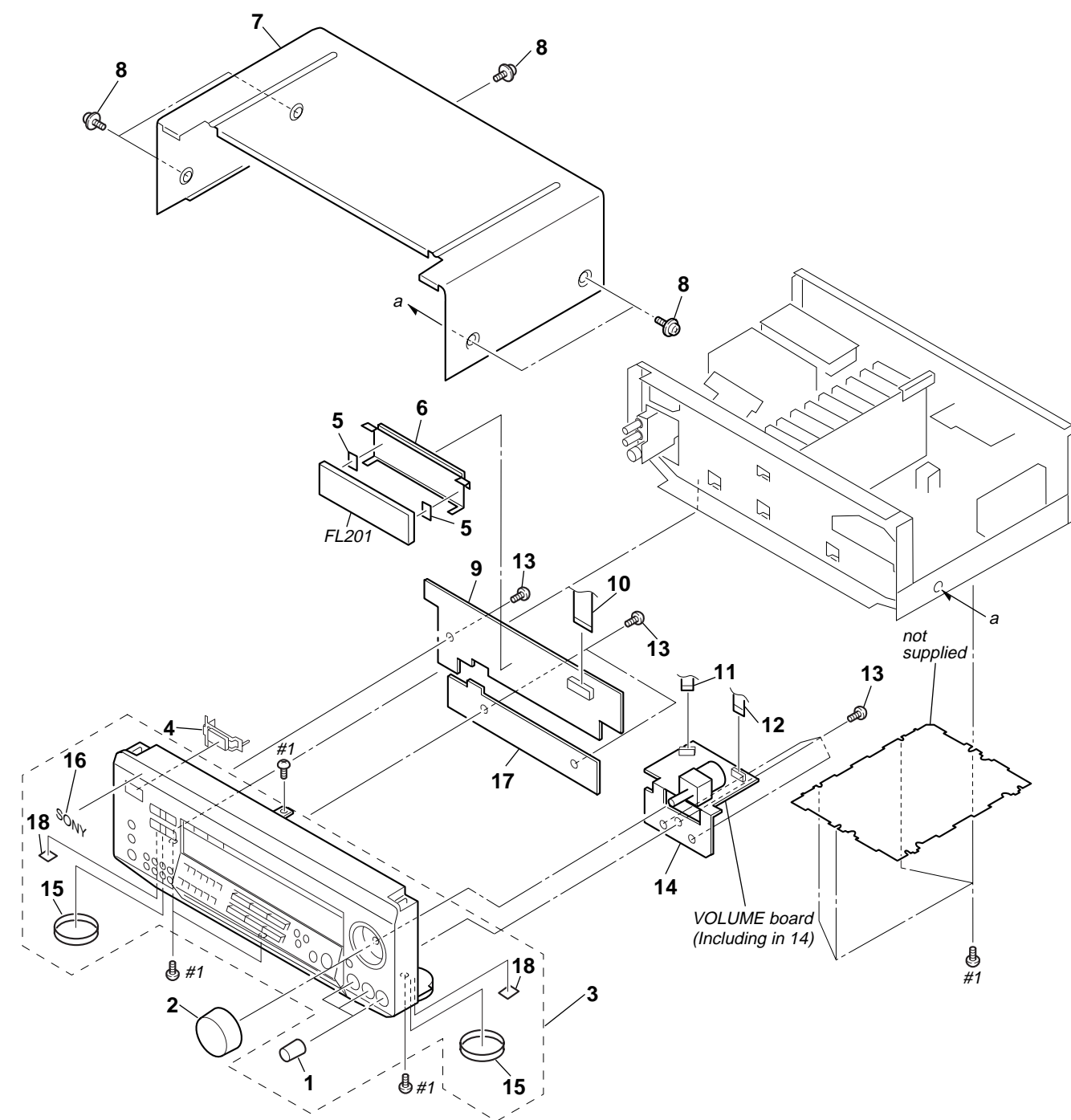

Ref. No.	Part No.	Description	Remarks	Ref. No.	Part No.	Description	Remarks
1	4-980-639-01	KNOB (R14)		* 9	A-4392-987-A	DISPLAY BOARD, COMPLETE (DE415:AUS)	
2	X-4946-873-1	KNOB (R48) ASSY		* 9	A-4392-993-A	DISPLAY BOARD, COMPLETE (DE315:AUS)	
3	X-4948-337-1	PANEL ASSY, FRONT (DE315:US,CND)		* 9	A-4392-995-A	DISPLAY BOARD, COMPLETE (DE315:SP,MY,CH)	
3	X-4948-338-1	PANEL ASSY, FRONT (DE415:US,CND)		* 9	A-4392-997-A	DISPLAY BOARD, COMPLETE (DE315:E)	
3	X-4948-369-1	PANEL ASSY, FRONT (DE415:AUS)		10	1-782-084-11	WIRE (FLAT TYPE) (23 CORE) (D360Z/DE315:US,CND,E,AUS/DE415)	
3	X-4948-371-1	PANEL ASSY, FRONT (D360Z)		11	1-782-075-11	WIRE (FLAT TYPE) (9 CORE)	
3	X-4948-372-1	PANEL ASSY, FRONT (DE315:AUS)		12	1-782-074-11	WIRE (FLAT TYPE) (7 CORE)	
3	X-4948-373-1	PANEL ASSY, FRONT (DE315:SP,MY,CH)		13	4-951-620-01	SCREW (2.6X8), +BVTP	
3	X-4948-473-1	PANEL ASSY, FRONT (DE315:E)		* 14	A-4392-788-A	VR-TONE BOARD, COMPLETE	
4	4-980-109-01	BUTTON (P-M) (DE315:SP,MY,CH)		15	4-977-593-11	RING (DIA. 50), ORNAMENTAL (DE315:E,SP,MY,AUS,CH/DE415:AUS)	
4	4-989-843-01	BUTTON (P-T) (EXCEPT DE315:SP,MY,CH)		16	3-008-600-11	EMBLEM (5-AR), SONY	
* 5	4-921-941-01	CUSHION (FL)		* 17	A-4392-790-A	KEY BOARD, COMPLETE (EXCEPT DE315:US,CND)	
* 6	4-943-107-12	HOLDER (FL TUBE)		* 17	A-4392-811-A	KEY BOARD, COMPLETE (DE315:US,CND)	
* 7	4-980-658-01	CASE (413226)		18	4-977-358-11	CUSHION (8X12.5)	
8	3-704-366-01	SCREW (CASE) (M3X8)		FL201	1-517-141-11	INDICATOR TUBE, FLUORESCENT	
* 9	A-4392-786-A	DISPLAY BOARD, COMPLETE (D360Z/DE415:US,CND)					
* 9	A-4392-795-A	DISPLAY BOARD, COMPLETE (DE315:US,CND)					

### 4-2. CHASSIS SECTION

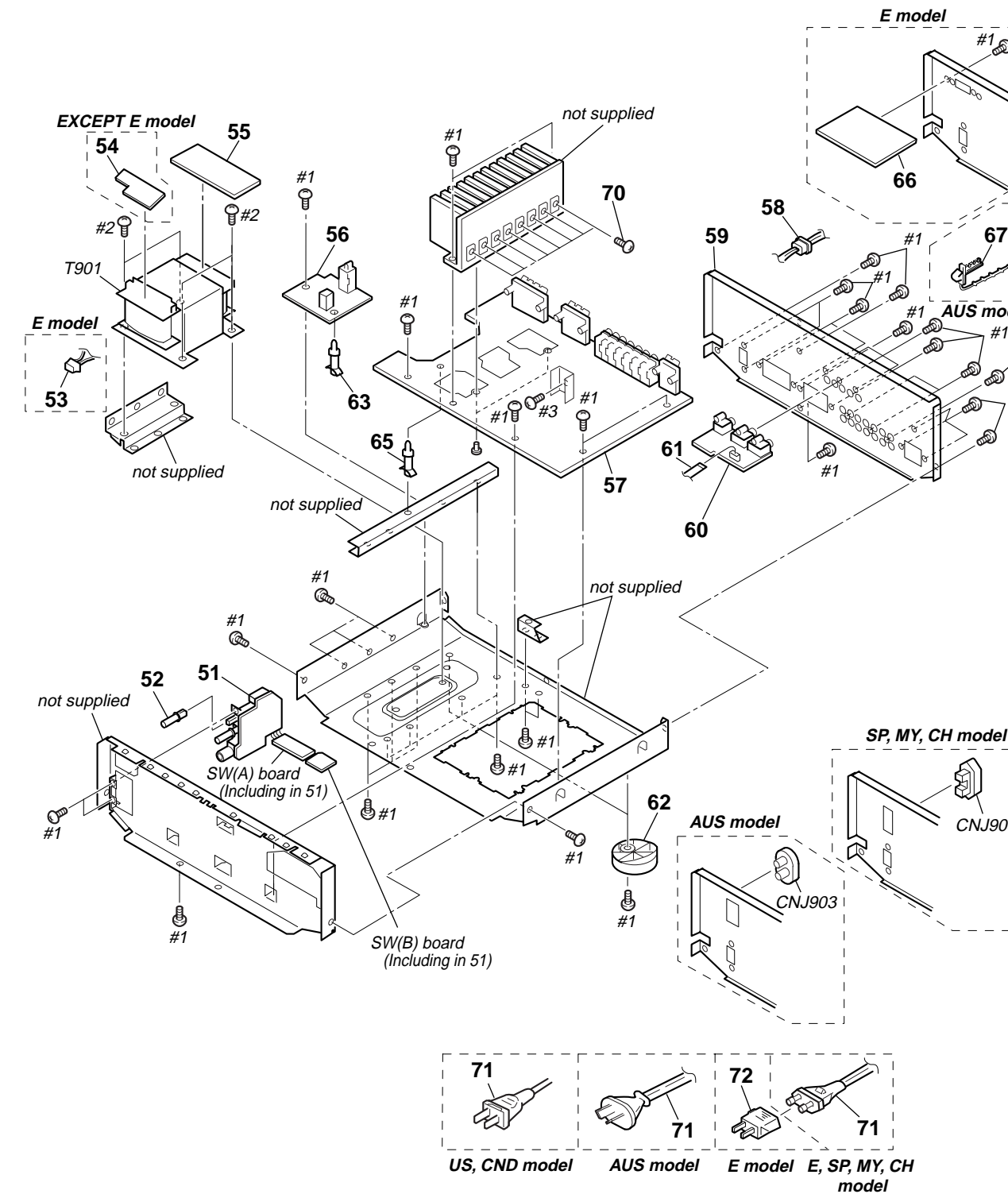

Ref. No.	Part No.	Description	Remarks	Ref. No.	Part No.	Description	Remarks
* 51	A-4392-789-A	SW BOARD, COMPLETE		62	X-4947-207-1	FOOT ASSY (F50150S) (DE315:E,SP,MY,AUS,CH/DE415:AUS)	
52	4-951-801-01	BUTTON (S)		62	X-4947-208-1	FOOT ASSY (F50150S) (D360Z/DE315:US,CND/DE415:US,CND)	
53	1-769-746-61	LEAD (WITH CONNECTOR) (2 CORE)(DE315:E)		* 63	4-924-098-01	HOLDER, PC BOARD	
* 54	1-665-273-11	PRIMARY BOARD (D360Z/DE315:US,CND,SP,MY,AUS,CH/DE415)		* 65	4-924-098-21	HOLDER, PC BOARD	
* 55	1-665-274-11	SECONDARY BOARD		* 66	1-665-275-11	SELECTOR BOARD (DE315:E)	
* 56	1-665-272-11	STBY BOARD		67	4-956-370-12	BAND, PLUG FIXED (DE315:AUS/DE415:AUS)	
* 57	A-4392-794-A	MAIN BOARD, COMPLETE (DE415:US)		70	3-905-609-01	SCREW (TRANSISTOR)	
* 57	A-4392-810-A	MAIN BOARD, COMPLETE (DE315:US)		71	1-696-847-11	CORD, POWER (AUS)	
* 57	A-4392-986-A	MAIN BOARD, COMPLETE (DE415:CND)		71	1-777-070-11	CORD, POWER (US,CND)	
* 57	A-4392-989-A	MAIN BOARD, COMPLETE (DE415:AUS)		71	1-777-071-11	CORD, POWER (E,SP,MY,CH)	
* 57	A-4392-991-A	MAIN BOARD, COMPLETE (D360Z:US)		$\Delta$ 72	1-569-008-21	ADAPTOR, CONVERSION 2P (E)	
* 57	A-4392-992-A	MAIN BOARD, COMPLETE (DE315:CND)		$\Delta$ CNJ903	1-526-794-11	OUTLET, A.C. (SP,MY,CH)	
* 57	A-4392-994-A	MAIN BOARD, COMPLETE (DE315:AUS)		$\Delta$ CNJ903	1-251-416-11	OUTLET, A.C. (AUS)	
* 57	A-4392-996-A	MAIN BOARD, COMPLETE (DE315:SP,MY,CH)		$\Delta$ T901	1-431-258-11	TRANSFORMER, POWER (DE315:US)	
* 57	A-4392-999-A	MAIN BOARD, COMPLETE (DE315:E)		$\Delta$ T901	1-431-259-11	TRANSFORMER, POWER (DE315:CND)	
* 57	A-4398-840-A	MAIN BOARD, COMPLETE (D360Z:CND)		$\Delta$ T901	1-431-260-11	TRANSFORMER, POWER (DE315:SP,MY,CH)	
* 58	3-703-244-00	BUSHING (2104), CORD		$\Delta$ T901	1-431-261-11	TRANSFORMER, POWER (DE315:AUS)	
* 59	4-989-901-01	PANEL, BACK (DE315:US)		$\Delta$ T901	1-431-262-11	TRANSFORMER, POWER (DE315:E)	
* 59	4-989-901-11	PANEL, BACK (DE315:CND)		$\Delta$ T901	1-431-263-11	TRANSFORMER, POWER (DE315:US/DE415:US)	
* 59	4-989-901-21	PANEL, BACK (DE315:AUS)		$\Delta$ T901	1-431-264-11	TRANSFORMER, POWER (D360Z:CND/DE415:CND)	
* 59	4-989-901-31	PANEL, BACK (DE315:E)		$\Delta$ T901	1-431-265-11	TRANSFORMER, POWER (DE415:AUS)	
* 59	4-989-901-41	PANEL, BACK (DE315:SP,MY,CH)					
* 59	4-989-902-01	PANEL, BACK (DE415:US)					
* 59	4-989-902-11	PANEL, BACK (DE415:CND)					
* 59	4-989-902-21	PANEL, BACK (DE415:AUS)					
* 59	4-989-902-41	PANEL, BACK (D360Z)					
* 60	1-665-271-11	VIDEO BOARD (D360Z/DE415)					
61	1-782-086-11	WIRE (FLAT TYPE) (27 CORE)(DE315:SP,MY,CH)					

The components identified by mark  $\Delta$  or dotted line with mark  $\Delta$  are critical for safety. Replace only with part number specified.

Les composants identifiés par une marque  $\Delta$  sont critiques pour la sécurité. Ne les remplacer que par une pièce portant le numéro spécifique.



# SECTION 5 ELECTRICAL PARTS LIST

**DISPLAY**

**NOTE:**

When indicating parts by reference number, please include the board name.

The components identified by mark  $\Delta$  or dotted line with mark  $\Delta$  are critical for safety. Replace only with part number specified.

Les composants identifiés par une marque  $\Delta$  sont critiques pour la sécurité. Ne les remplacer que par une pièce portant le numéro spécifié.

- Due to standardization, replacements in the parts list may be different from the parts specified in the diagrams or the components used on the set.
- -XX, -X mean standardized parts, so they may have some difference from the original one.
- Items marked "\*" are not stocked since they are seldom required for routine service. Some delay should be anticipated when ordering these items.
- CAPACITORS:  
uF:  $\mu$ F
- RESISTORS  
All resistors are in ohms.  
METAL: metal-film resistor  
METAL OXIDE: Metal Oxide-film resistor  
F: nonflammable
- COILS  
uH:  $\mu$ H
- SEMICONDUCTORS  
In each case, u:  $\mu$ , for example:  
uA...:  $\mu$ A..., uPA...,  $\mu$ PA...,  
uPB...,  $\mu$ PB..., uPC...,  $\mu$ PC...,  
uPD...,  $\mu$ PD...

SP : Singapore    MY : Malaysia  
AU : Australian    CND : Canadian  
CH : Chinese

Ref. No.	Part No.	Description	Remarks	Ref. No.	Part No.	Description	Remarks
*	A-4392-786-A	DISPLAY BOARD, COMPLETE (D360/DE415: ***** US,CND)				< FILTER >	
*	A-4392-795-A	DISPLAY BOARD, COMPLETE (DE315:US,CND) *****		FL201	1-517-141-11	INDICATOR TUBE, FLUORESCENT	
*	A-4392-997-A	DISPLAY BOARD, COMPLETE (DE315:E) *****				< IC >	
*	A-4392-993-A	DISPLAY BOARD, COMPLETE (DE315:AUS) *****		IC201	8-759-462-31	IC uPD78044FGF-041-3B9	
*	A-4392-987-A	DISPLAY BOARD, COMPLETE (DE415:AUS) *****		IC202	8-759-962-08	IC BA6208	
*	A-4392-995-A	DISPLAY BOARD, COMPLETE (DE315:SP,MY,CH) *****		IC203	8-759-332-18	IC GP1U27XB(REMOTE SENSOR)	
		< CAPACITOR >				< COIL >	
				L401	1-410-509-11	INDUCTOR    10uH	
						< TRANSISTOR >	
C201	1-104-905-11	CAPACITOR    0.22F    5.5V		Q201	8-729-900-63	TRANSISTOR    DTA124ES	
C202	1-164-159-11	CERAMIC    0.1uF    50V		Q202	8-729-900-36	TRANSISTOR    DTC124ES	
C203	1-124-465-00	ELECT    0.47uF    20%    50V		Q203	8-729-900-36	TRANSISTOR    DTC124ES (DE315:SP,MY,CH)	
C204	1-164-159-11	CERAMIC    0.1uF    50V		Q231	8-729-900-36	TRANSISTOR    DTC124ES	
C205	1-162-294-31	CERAMIC    0.001uF    10%    50V				< RESISTOR >	
C206	1-164-159-11	CERAMIC    0.1uF    50V		R200	1-249-433-11	CARBON    22K    5%    1/4W	
C207	1-126-096-11	ELECT    10uF    20%    35V		R201	1-247-903-00	CARBON    1M    5%    1/4W	
		< CONNECTOR >		R202	1-249-429-11	CARBON    10K    5%    1/4W	
CNP205	1-779-366-11	CONNECTOR, BOARD TO BOARD 4P		R203	1-249-429-11	CARBON    10K    5%    1/4W	
CNS201	1-569-327-11	SOCKET, CONNECTOR 27P (DE315:SP,MY,CH)		R204	1-249-425-11	CARBON    4.7K    5%    1/4W F	
CNS201	1-568-742-11	SOCKET, CONNECTOR 23P (D360Z/DE315:US,CND,E,AUS/DE415)		R205	1-249-441-11	CARBON    100K    5%    1/4W	
CNS202	1-770-400-11	HOUSING, CONNECTOR (PC BOARD)7P		R206	1-249-429-11	CARBON    10K    5%    1/4W (DE315:SP,MY,CH)	
		< DIODE >		R207	1-249-429-11	CARBON    10K    5%    1/4W	
D201	8-719-987-63	DIODE    1N4148M		R211	1-249-433-11	CARBON    22K    5%    1/4W	
D202	8-719-987-63	DIODE    1N4148M		R212	1-249-433-11	CARBON    22K    5%    1/4W	
D203	8-719-987-63	DIODE    1N4148M		R213	1-249-433-11	CARBON    22K    5%    1/4W	
D204	8-719-987-63	DIODE    1N4148M		R214	1-249-433-11	CARBON    22K    5%    1/4W	
D211	8-719-987-63	DIODE    1N4148M		R216	1-249-433-11	CARBON    22K    5%    1/4W	
D212	8-719-987-63	DIODE    1N4148M		R221	1-247-807-31	CARBON    100    5%    1/4W	
D213	8-719-987-63	DIODE    1N4148M		R222	1-247-807-31	CARBON    100    5%    1/4W	
D214	8-719-987-63	DIODE    1N4148M		R223	1-247-807-31	CARBON    100    5%    1/4W	
D221	8-719-987-63	DIODE    1N4148M (DE315:SP,MY,CH)		R224	1-247-807-31	CARBON    100    5%    1/4W	
D222	8-719-987-63	DIODE    1N4148M (DE315:E,SP,MY,AUS,CH/DE415:AUS)		R225	1-247-807-31	CARBON    100    5%    1/4W	
D223	8-719-987-63	DIODE    1N4148M (DE315:AUS/DE415:AUS)		R226	1-249-441-11	CARBON    100K    5%    1/4W	
D225	8-719-987-63	DIODE    1N4148M (DE315)		R227	1-249-441-11	CARBON    100K    5%    1/4W	
D231	8-719-987-63	DIODE    1N4148M		R228	1-249-412-11	CARBON    390    5%    1/4W F	
D233	8-719-313-48	DIODE    SEL6210S-TH12 (DE315:E,SP,MY,AUS,CH/DE415:AUS)		R229	1-249-410-11	CARBON    270    5%    1/4W F (DE315:E,SP,MY,AUS,CH/DE415:AUS)	
D235	8-719-313-50	DIODE    SEL6810A-TH12(HALL)		R230	1-249-410-11	CARBON    270    5%    1/4W F	
D236	8-719-313-50	DIODE    SEL6810A-TH12(C.STUD10)		R231	1-249-427-11	CARBON    6.8K    5%    1/4W F	
D237	8-719-313-50	DIODE    SEL6810A-TH12(PRO LOGIC)		R283	1-249-427-11	CARBON    6.8K    5%    1/4W F	
				R284	1-249-427-11	CARBON    6.8K    5%    1/4W F	
				R286	1-249-437-11	CARBON    47K    5%    1/4W	

**DISPLAY**   **KEY**   **MAIN**

Ref. No.	Part No.	Description	Remarks
		< SWITCH >	
S200	1-762-751-11	SWITCH, TACTILE (POWER) (D360Z/DE315:US,CND,E,AUS/DE415)	
S201	1-762-751-11	SWITCH, TACTILE (CENTER LEVEL-)	
S202	1-762-751-11	SWITCH, TACTILE (CENTER LEVEL+)	
S203	1-762-751-11	SWITCH, TACTILE (REAR LEVEL-)	
S204	1-762-751-11	SWITCH, TACTILE (REAR LEVEL+)	
S209	1-762-751-11	SWITCH, TACTILE (TUNING -)	
S210	1-762-751-11	SWITCH, TACTILE (TUNING +)	
S211	1-762-751-11	SWITCH, TACTILE (PRESET TUNING -)	
S212	1-762-751-11	SWITCH, TACTILE (PRESET TUNING+)	
S213	1-762-751-11	SWITCH, TACTILE (FM MODE)	
S214	1-762-751-11	SWITCH, TACTILE(FM)	
S215	1-762-751-11	SWITCH, TACTILE(AM)	
S216	1-762-751-11	SWITCH, TACTILE(MEMORY)	
SW200	1-771-054-11	SWITCH, PUSH (1 KEY)(POWER) (DE315:SP,MY,CH)	
		< VIBRATOR >	
X201	1-577-101-11	VIBRATOR, CERAMIC 4.19MHz	
*****			
*	A-4392-790-A	KEY BOARD, COMPLETE (D360Z/DE315:E,SP, ***** MY,AUS,CH/DE415)	
*	A-4392-811-A	KEY BOARD, COMPLETE (DE315:US,CND) *****	
		< CONNECTOR >	
CNS205	1-770-397-11	HOUSING, CONNECTOR(PC BOARD)4P	
		< RESISTOR >	
R232	1-249-411-11	CARBON      330      5%      1/4W	
R233	1-249-413-11	CARBON      470      5%      1/4W F	
R234	1-249-415-11	CARBON      680      5%      1/4W F	
R235	1-249-417-11	CARBON      1K        5%      1/4W F	
R236	1-249-419-11	CARBON      1.5K     5%      1/4W F	
R237	1-249-421-11	CARBON      2.2K     5%      1/4W F	
R238	1-247-843-11	CARBON      3.3K     5%      1/4W	
R239	1-249-411-11	CARBON      330      5%      1/4W	
R240	1-249-413-11	CARBON      470      5%      1/4W F	
R241	1-249-415-11	CARBON      680      5%      1/4W F	
R242	1-249-417-11	CARBON      1K        5%      1/4W F	
R243	1-249-419-11	CARBON      1.5K     5%      1/4W F	
R244	1-249-421-11	CARBON      2.2K     5%      1/4W F	
R245	1-247-843-11	CARBON      3.3K     5%      1/4W	
R246	1-249-411-11	CARBON      330      5%      1/4W	
R247	1-249-413-11	CARBON      470      5%      1/4W F	
R248	1-249-415-11	CARBON      680      5%      1/4W F	
R249	1-249-417-11	CARBON      1K        5%      1/4W F	
R280	1-249-419-11	CARBON      1.5K     5%      1/4W F	
R281	1-249-421-11	CARBON      2.2K     5%      1/4W F	
R282	1-247-843-11	CARBON      3.3K     5%      1/4W	
		< SWITCH >	
S217	1-762-751-11	SWITCH, TACTILE (SURROUND ON/OFF)	
S218	1-762-751-11	SWITCH, TACTILE (SET UP)	
S219	1-762-751-11	SWITCH, TACTILE (EFFECT/DELAY TIME)	
S220	1-762-751-11	SWITCH, TACTILE (TV/DBS) (D360Z/DE315:E,SP,MY,AUS,CH/DE415)	
S221	1-762-751-11	SWITCH, TACTILE (TUNER)	

Ref. No.	Part No.	Description	Remarks
S222	1-762-751-11	SWITCH, TACTILE (PHONO)	
S223	1-762-751-11	SWITCH, TACTILE (VIDEO)	
S224	1-762-751-11	SWITCH, TACTILE (6)	
S225	1-762-751-11	SWITCH, TACTILE (7)	
S226	1-762-751-11	SWITCH, TACTILE (8)	
S227	1-762-751-11	SWITCH, TACTILE (9)	
S228	1-762-751-11	SWITCH, TACTILE (0)	
S229	1-762-751-11	SWITCH, TACTILE (SHIFT)	
S231	1-762-751-11	SWITCH, TACTILE (TAPE/MD)	
S232	1-762-751-11	SWITCH, TACTILE (1)	
S233	1-762-751-11	SWITCH, TACTILE (2)	
S234	1-762-751-11	SWITCH, TACTILE (3)	
S235	1-762-751-11	SWITCH, TACTILE (4)	
S236	1-762-751-11	SWITCH, TACTILE (5)	
S237	1-762-751-11	SWITCH, TACTILE (DIRECT)	
S238	1-762-751-11	SWITCH, TACTILE (MODE)	
S239	1-762-751-11	SWITCH, TACTILE (CD)	
*****			
*	A-4392-991-A	MAIN BOARD, COMPLETE (D360Z:US) *****	
	A-4398-840-A	MAIN BOARD, COMPLETE (D360Z:CND) *****	
*	A-4392-810-A	MAIN BOARD, COMPLETE (DE315:US) *****	
*	A-4392-992-A	MAIN BOARD, COMPLETE (DE315:CND) *****	
*	A-4392-999-A	MAIN BOARD, COMPLETE (DE315:E) *****	
*	A-4392-996-A	MAIN BOARD, COMPLETE (DE315:SP,MY,CH) *****	
*	A-4392-994-A	MAIN BOARD, COMPLETE (DE315:AUS) *****	
*	A-4392-794-A	MAIN BOARD, COMPLETE (DE415:US) *****	
*	A-4392-986-A	MAIN BOARD, COMPLETE (DE415:CND) *****	
*	A-4392-989-A	MAIN BOARD, COMPLETE (DE415:AUS) *****	
	3-905-609-01	SCREW (TRANSISTOR)	
	4-812-134-00	RIVET (DIA. 3.5), NYLON	
	7-685-646-79	SCREW +BVTP 3X8 TYPE2 IT-T2	
	7-685-872-09	SCREW +BVTT 3X8 (S)	
		< CAPACITOR >	
C302	1-126-934-11	ELECT      220uF      20%      16V	
C303	1-130-494-11	MYLAR      0.082uF    5%      50V	
C304	1-137-367-11	FILM        0.0033uF   5%      50V	
C305	1-130-494-11	MYLAR      0.082uF    5%      50V	
C306	1-126-959-11	ELECT      0.47uF     20%     50V	
C307	1-126-964-11	ELECT      10uF       20%     50V	
C308	1-126-964-11	ELECT      10uF       20%     50V	
C309	1-162-291-31	CERAMIC    560PF      10%     50V	
C310	1-126-962-11	ELECT      3.3uF      20%     50V	
C311	1-126-961-11	ELECT      2.2uF      20%     50V	
C312	1-126-934-11	ELECT      220uF      20%     16V	
C313	1-126-934-11	ELECT      220uF      20%     16V	
C314	1-136-165-00	FILM        0.1uF      5%      50V	
C316	1-124-252-00	ELECT      0.33uF     20%     50V	
C317	1-126-933-11	ELECT      100uF      20%     16V	
C318	1-137-363-91	FILM        680PF      5%      50V	
C322	1-126-962-11	ELECT      3.3uF      20%     50V	
C323	1-136-173-00	FILM        0.47uF     5%      50V	
C324	1-126-967-11	ELECT      47uF       20%     16V	
C325	1-136-165-00	FILM        0.1uF      5%      50V	

Ref. No.	Part No.	Description	Remarks	Ref. No.	Part No.	Description	Remarks
C326	1-136-165-00	FILM	0.1uF 5% 50V	C416	1-164-159-11	CERAMIC	0.1uF 50V
C327	1-126-959-11	ELECT	0.47uF 20% 50V	C434	1-162-286-31	CERAMIC	220PF 10% 50V
C328	1-126-963-11	ELECT	4.7uF 20% 50V	C435	1-162-286-31	CERAMIC	220PF 10% 50V
C329	1-126-959-11	ELECT	0.47uF 20% 50V	C451	1-162-282-31	CERAMIC	100PF 10% 50V
C330	1-126-963-11	ELECT	4.7uF 20% 50V			(D360Z/DE315:E,SP,MY,AUS,CH/DE415)	
C331	1-124-250-11	ELECT	0.15uF 20% 50V	C452	1-126-962-11	ELECT	3.3uF 20% 50V
C332	1-126-962-11	ELECT	3.3uF 20% 50V			(D360Z/DE315:E,SP,MY,AUS,CH/DE415)	
C333	1-124-250-11	ELECT	0.15uF 20% 50V	C453	1-126-966-11	ELECT	33uF 20% 16V
C334	1-137-372-11	FILM	0.022uF 5% 50V			(D360Z/DE315:E,SP,MY,AUS,CH/DE415)	
C335	1-136-161-00	FILM	0.047uF 5% 50V	C454	1-162-282-31	CERAMIC	100PF 10% 50V
C336	1-126-934-11	ELECT	220uF 20% 16V			(D360Z/DE315:E,SP,MY,AUS,CH/DE415)	
C337	1-126-964-11	ELECT	10uF 20% 50V	C455	1-137-459-11	FILM	0.0056uF 5% 100V
C338	1-126-964-11	ELECT	10uF 20% 50V			(D360Z/DE315:E,SP,MY,AUS,CH/DE415)	
C339	1-126-964-11	ELECT	10uF 20% 50V	C457	1-137-365-11	FILM	0.0015uF 5% 50V
C340	1-126-964-11	ELECT	10uF 20% 50V			(D360Z/DE315:E,SP,MY,AUS,CH/DE415)	
C341	1-126-934-11	ELECT	220uF 20% 16V	C459	1-126-962-11	ELECT	3.3uF 20% 50V
C342	1-126-962-11	ELECT	3.3uF 20% 50V			(D360Z/DE315:E,SP,MY,AUS,CH/DE415)	
C343	1-126-962-11	ELECT	3.3uF 20% 50V	C460	1-164-159-11	CERAMIC	0.1uF 50V
C344	1-136-165-00	FILM	0.1uF 5% 50V			(D360Z/DE315:E,SP,MY,AUS,CH/DE415)	
C345	1-136-165-00	FILM	0.1uF 5% 50V	C602	1-162-288-31	CERAMIC	330PF 10% 50V
C346	1-126-959-11	ELECT	0.47uF 20% 50V	C603	1-126-933-11	ELECT	100uF 20% 10V
C347	1-126-963-11	ELECT	4.7uF 20% 50V	C605	1-102-233-00	CERAMIC	33PF 10% 500V
C348	1-126-959-11	ELECT	0.47uF 20% 50V	C610	1-126-967-11	ELECT	47uF 20% 16V
C349	1-126-963-11	ELECT	4.7uF 20% 50V	C611	1-137-372-11	FILM	0.022uF 5% 50V
C350	1-124-250-11	ELECT	0.15uF 20% 50V	C620	1-162-286-31	CERAMIC	220PF 10% 50V
C351	1-126-962-11	ELECT	3.3uF 20% 50V	C652	1-162-282-31	CERAMIC	100PF 10% 50V
C352	1-124-250-11	ELECT	0.15uF 20% 50V	C653	1-126-933-11	ELECT	100uF 20% 10V
C353	1-164-159-11	CERAMIC	0.1uF 50V	C655	1-102-233-00	CERAMIC	33PF 10% 500V
C354	1-164-159-11	CERAMIC	0.1uF 50V	C660	1-126-967-11	ELECT	47uF 20% 16V
C355	1-164-159-11	CERAMIC	0.1uF 50V	C661	1-137-372-11	FILM	0.022uF 5% 50V
C356	1-164-159-11	CERAMIC	0.1uF 50V	C670	1-162-286-31	CERAMIC	220PF 10% 50V
C357	1-164-159-11	CERAMIC	0.1uF 50V	C702	1-162-282-31	CERAMIC	100PF 10% 50V
C359	1-126-963-11	ELECT	4.7uF 20% 50V	C703	1-126-933-11	ELECT	100uF 20% 10V
C360	1-126-963-11	ELECT	4.7uF 20% 50V	C705	1-102-233-00	CERAMIC	33PF 10% 500V
C363	1-164-159-11	CERAMIC	0.1uF 50V	C710	1-126-967-11	ELECT	47uF 20% 16V
C365	1-126-966-11	ELECT	33uF 20% 16V	C711	1-137-372-11	FILM	0.022uF 5% 50V
C366	1-164-159-11	CERAMIC	0.1uF 50V	C720	1-162-286-31	CERAMIC	220PF 10% 50V
C401	1-162-282-31	CERAMIC	100PF 10% 50V	C721	1-126-923-11	ELECT	220uF 20% 10V
			(D360Z/DE315:E,SP,MY,AUS,CH/DE415)	C722	1-126-965-11	ELECT	22uF 20% 50V
C402	1-126-962-11	ELECT	3.3uF 20% 50V	C740	1-128-562-11	ELECT	47uF 20% 100V
			(D360Z/DE315:E,SP,MY,AUS,CH/DE415)	C741	1-128-562-11	ELECT	47uF 20% 100V
C403	1-126-966-11	ELECT	33uF 20% 16V	C742	1-126-925-11	ELECT	470uF 20% 10V
			(D360Z/DE315:E,SP,MY,AUS,CH/DE415)	C743	1-126-925-11	ELECT	470uF 20% 10V
C404	1-162-282-31	CERAMIC	100PF 10% 50V	C752	1-162-282-31	CERAMIC	100PF 10% 50V
			(D360Z/DE315:E,SP,MY,AUS,CH/DE415)	C753	1-126-933-11	ELECT	100uF 20% 10V
C405	1-137-459-11	FILM	0.0056uF 5% 100V	C755	1-102-233-00	CERAMIC	33PF 10% 500V
			(D360Z/DE315:E,SP,MY,AUS,CH/DE415)	C760	1-126-967-11	ELECT	47uF 20% 16V
C406	1-164-159-11	CERAMIC	0.1uF 50V	C761	1-137-372-11	FILM	0.022uF 5% 50V
C407	1-137-365-11	FILM	0.0015uF 5% 50V	C770	1-162-286-31	CERAMIC	220PF 10% 50V
			(D360Z/DE315:E,SP,MY,AUS,CH/DE415)	C801	1-104-664-11	ELECT	47uF 20% 25V
C408	1-162-294-31	CERAMIC	0.001uF 10% 50V	C802	1-104-664-11	ELECT	47uF 20% 25V
C409	1-126-962-11	ELECT	3.3uF 20% 50V	C803	1-107-766-11	ELECT	8200uF 20% 71V
			(D360Z/DE315:E,SP,MY,AUS,CH/DE415)			(D360Z:CND/DE315:US/DE415:CND,AUS)	
C410	1-164-159-11	CERAMIC	0.1uF 50V	C803	1-128-591-11	ELECT	6800uF 20% 56V
			(D360Z/DE315:E,SP,MY,AUS,CH/DE415)			(DE315:CND,E,SP,MY,AUS,CH)	
C412	1-162-291-31	CERAMIC	560PF 10% 50V	C803	1-109-932-11	ELECT	10000uF 20% 71V
C413	1-164-159-11	CERAMIC	0.1uF 50V			(D360Z:US/DE415:US)	
C415	1-164-159-11	CERAMIC	0.1uF 50V	C804	1-107-766-11	ELECT	8200uF 20% 71V
						(D360Z:CND/DE315:US/DE415:CND,AUS)	
				C804	1-128-591-11	ELECT	6800uF 20% 56V
						(DE315:CND,E,SP,MY,AUS,CH)	
				C804	1-109-932-11	ELECT	10000uF 20% 71V
						(D360Z:US/DE415:US)	

**MAIN**

Ref. No.	Part No.	Description	Remarks
C805	1-130-781-00	FILM 0.22uF 10% 100V (DE315:AUS/DE415:AUS)	
C805	1-137-420-11	FILM 0.047uF 10% 100V (D360Z/DE315:US,CND,E,SP,MY,CH/DE415:US,CND)	
C806	1-130-781-00	FILM 0.22uF 10% 100V (DE315:AUS/DE415:AUS)	
C806	1-137-420-11	FILM 0.047uF 10% 100V (D360Z/DE315:US,CND,E,SP,MY,CH/DE415:US,CND)	
C807	1-104-664-11	ELECT 47uF 20% 25V	
C808	1-104-664-11	ELECT 47uF 20% 25V	
C809	1-126-960-11	ELECT 1uF 20% 50V	
C810	1-126-960-11	ELECT 1uF 20% 50V	
C811	1-126-942-61	ELECT 1000uF 20% 25V	
C812	1-126-942-61	ELECT 1000uF 20% 25V	
C813	1-101-001-00	CERAMIC 0.001uF 50V	
C814	1-101-001-00	CERAMIC 0.001uF 50V	
C820	1-161-494-00	CERAMIC 0.022uF 25V	
C821	1-161-494-00	CERAMIC 0.022uF 25V	
C822	1-104-664-11	ELECT 47uF 20% 25V	
C823	1-104-664-11	ELECT 47uF 20% 25V	
C950	1-126-767-11	ELECT 1000uF 20% 16V	
C951	1-164-097-11	CERAMIC 0.022uF 50V	
C952	1-126-960-11	ELECT 1uF 20% 50V	
C953	1-124-464-11	ELECT 0.22uF 20% 50V	
C954	1-126-096-11	ELECT 10uF 20% 35V	
C955	1-164-159-11	CERAMIC 0.1uF 50V	
< CONNECTOR >			
CNP702	1-750-388-11	PIN, CONNECTOR 5P	
CNS204	1-569-327-11	SOCKET, CONNECTOR 27P (DE315:SP,MY,CH)	
CNS204	1-568-742-11	SOCKET, CONNECTOR 23P (D360Z/DE315:US,CND,E,AUS/DE415)	
CNS251	1-568-439-11	SOCKET, CONNECTOR 7P	
CNS301	1-568-442-11	SOCKET, CONNECTOR 9P	
CNS701	1-568-439-11	SOCKET, CONNECTOR 7P	
CNS802	1-770-480-12	SOCKET, CONNECTOR PIN 4P	
< DIODE >			
D610	8-719-987-63	DIODE 1N4148M	
D710	8-719-987-63	DIODE 1N4148M	
D721	8-719-815-85	DIODE 1S1585	
D722	8-719-815-85	DIODE 1S1585	
D723	8-719-987-63	DIODE 1N4148M	
D724	8-719-987-63	DIODE 1N4148M	
D725	8-719-987-63	DIODE 1N4148M	
D801	8-719-002-33	DIODE UZL-24L	
D802	8-719-302-38	DIODE RBV-602-01	
D804	8-719-010-38	DIODE UZ-5.1BSB	
D810	8-719-024-99	DIODE 11ES2-NTA2B	
D811	8-719-024-99	DIODE 11ES2-NTA2B	
D812	8-719-024-99	DIODE 11ES2-NTA2B	
D813	8-719-024-99	DIODE 11ES2-NTA2B	
D814	8-719-987-63	DIODE 1N4148M	
D815	8-719-987-63	DIODE 1N4148M	
D817	8-719-001-30	DIODE UZL-9H3	
D818	8-719-987-63	DIODE 1N4148M	
D820	8-719-024-99	DIODE 11ES2-NTA2B	
D821	8-719-024-99	DIODE 11ES2-NTA2B	
D822	8-719-024-99	DIODE 11ES2-NTA2B	
D823	8-719-024-99	DIODE 11ES2-NTA2B	
D901	8-719-987-63	DIODE 1N4148M	

Ref. No.	Part No.	Description	Remarks
< TERMINAL >			
* G200	1-537-738-21	TERMINAL, EARTH	
* G201	1-537-738-21	TERMINAL, EARTH	
* G202	1-537-738-21	TERMINAL, EARTH	
< IC >			
IC300	8-759-442-97	IC LV1016	
IC301	8-759-442-96	IC LA2786	
IC302	8-759-636-74	IC M5218AP-22	
IC401	8-759-805-14	IC LC7822	
IC402	8-759-636-74	IC M5218AP-22 (D360Z/DE315:CND,E,SP,MY,AUS,CH/DE415)	
IC701	8-759-326-52	IC uPC2581V	
IC702	8-759-326-52	IC uPC2581V	
IC801	8-759-231-58	IC TA7812S	
IC802	8-759-604-45	IC M5F79M12	
IC950	8-759-333-83	IC NJM2103D	
< JACK >			
J401	1-770-614-11	JACK,PIN 4P (PHONO/CD) (D360Z/DE315:E,SP,MY,AUS,CH/DE415)	
J402	1-580-825-11	JACK,PIN 6P (TAPE/MD,TV DBS AUDIO IN) (D360Z/DE315:E,SP,MY,AUS,CH/DE415)	
J402	1-691-887-11	JACK,PIN 6P (CD/TAPE/MD)(DE315:US,CND)	
J403	1-691-887-11	JACK,PIN 6P (TV/DBS/VIDEO)(DE315:US,CND)	
J403	1-770-613-11	JACK,PIN 4P (VIDEO) (D360Z/DE315:E,SP,MY,AUS,CH/DE415)	
< COIL >			
L301	1-410-509-11	INDUCTOR 10uH	
L302	1-410-509-11	INDUCTOR 10uH	
L601	1-420-872-00	COIL, AIR-CORE	
L651	1-420-872-00	COIL, AIR-CORE	
L701	1-420-872-00	COIL, AIR-CORE	
L751	1-420-872-00	COIL, AIR-CORE	
< TRANSISTOR >			
Q303	8-729-922-37	TRANSISTOR 2SD2144S	
Q304	8-729-922-37	TRANSISTOR 2SD2144S	
Q307	8-729-922-37	TRANSISTOR 2SD2144S	
Q308	8-729-922-37	TRANSISTOR 2SD2144S	
Q601	8-729-119-76	TRANSISTOR 2SA1175-HFE	
Q602	8-729-141-30	TRANSISTOR 2SC3623A-LK	
Q603	8-749-010-25	IC MN2488-OPY-M	
Q604	8-749-010-26	IC MP1620-OPY-M	
Q610	8-729-119-78	TRANSISTOR 2SC403SP-51	
Q620	8-729-140-82	TRANSISTOR 2SA988-PAFAEA	
Q651	8-729-119-76	TRANSISTOR 2SA1175-HFE	
Q652	8-729-141-30	TRANSISTOR 2SC3623A-LK	
Q653	8-749-010-25	IC MN2488-OPY-M	
Q654	8-749-010-26	IC MP1620-OPY-M	
Q670	8-729-140-82	TRANSISTOR 2SA988-PAFAEA	
Q701	8-729-119-76	TRANSISTOR 2SA1175-HFE	
Q702	8-729-141-30	TRANSISTOR 2SC3623A-LK	
Q703	8-749-010-25	IC MN2488-OPY-M	
Q704	8-749-010-26	IC MP1620-OPY-M	
Q710	8-729-119-78	TRANSISTOR 2SC403SP-51	
Q720	8-729-140-82	TRANSISTOR 2SA988-PAFAEA	
Q721	8-729-140-82	TRANSISTOR 2SA988-PAFAEA	
Q722	8-729-140-84	TRANSISTOR 2SC1841-PAFAEA	
Q723	8-729-119-78	TRANSISTOR 2SC403SP-51	
Q751	8-729-119-76	TRANSISTOR 2SA1175-HFE	

Ref. No.	Part No.	Description	Remarks	Ref. No.	Part No.	Description	Remarks
Q752	8-729-141-30	TRANSISTOR 2SC3623A-LK		R413	1-249-437-11	CARBON 47K 5% 1/4W (D360Z/DE315:E,SP,MY,AUS,CH/DE415)	
Q753	8-749-010-25	IC MN2488-OPY-M		R414	1-249-425-11	CARBON 4.7K 5% 1/4W F	
Q754	8-749-010-26	IC MP1620-OPY-M		R415	1-249-417-11	CARBON 1K 5% 1/4W F	
Q770	8-729-140-82	TRANSISTOR 2SA988-PAFAEA		R416	1-249-417-11	CARBON 1K 5% 1/4W F (D360Z/DE315:E,SP,MY,AUS,CH/DE415)	
Q801	8-729-140-97	TRANSISTOR 2SB734-34		R417	1-247-897-11	CARBON 560K 5% 1/4W (D360Z/DE315:E,SP,MY,AUS,CH/DE415)	
Q802	8-729-119-78	TRANSISTOR 2SC403SP-51		R420	1-249-441-11	CARBON 100K 5% 1/4W	
Q808	8-729-180-92	TRANSISTOR 2SD809-K		R435	1-249-418-11	CARBON 1.2K 5% 1/4W F	
Q809	8-729-119-78	TRANSISTOR 2SC403SP-51		R442	1-249-418-11	CARBON 1.2K 5% 1/4W F	
Q951	8-729-030-18	TRANSISTOR 2SD2525		R443	1-249-418-11	CARBON 1.2K 5% 1/4W F	
		< RESISTOR >		R447	1-249-416-11	CARBON 820 5% 1/4W F	
R298	1-249-385-11	CARBON 2.2 5% 1/6W F (DE415:US)		R448	1-249-429-11	CARBON 10K 5% 1/4W	
R298	1-249-389-11	CARBON 4.7 5% 1/4W F (DE415:CND)		R449	1-249-433-11	CARBON 22K 5% 1/4W	
R299	1-249-385-11	CARBON 2.2 5% 1/6W F (DE415:US)		R451	1-249-411-11	CARBON 330 5% 1/4W (D360Z/DE315:E,SP,MY,AUS,CH/DE415)	
R299	1-249-389-11	CARBON 4.7 5% 1/4W F (DE415:CND)		R452	1-249-421-11	CARBON 2.2K 5% 1/4W F	
R300	1-247-903-00	CARBON 1M 5% 1/4W		R453	1-249-417-11	CARBON 1K 5% 1/4W F	
R301	1-249-421-11	CARBON 2.2K 5% 1/4W F		R454	1-249-417-11	CARBON 1K 5% 1/4W F	
R302	1-249-421-11	CARBON 2.2K 5% 1/4W F		R455	1-249-417-11	CARBON 1K 5% 1/4W F	
R303	1-249-439-11	CARBON 68K 5% 1/4W		R456	1-249-417-11	CARBON 1K 5% 1/4W F	
R304	1-249-441-11	CARBON 100K 5% 1/4W		R457	1-249-417-11	CARBON 1K 5% 1/4W F	
R306	1-249-436-11	CARBON 39K 5% 1/4W		R458	1-249-429-11	CARBON 10K 5% 1/4W	
R307	1-247-862-11	CARBON 20K 5% 1/4W		R459	1-249-437-11	CARBON 47K 5% 1/4W (D360Z/DE315:E,SP,MY,AUS,CH/DE415)	
R308	1-249-421-11	CARBON 2.2K 5% 1/4W F		R460	1-247-897-11	CARBON 560K 5% 1/4W (D360Z/DE315:SP,MY,AUS,CH/DE415)	
R309	1-249-421-11	CARBON 2.2K 5% 1/4W F		R461	1-249-416-11	CARBON 820 5% 1/4W F (D360Z/DE315:E,SP,MY,AUS,CH/DE415)	
R352	1-249-441-11	CARBON 100K 5% 1/4W		R462	1-247-897-11	CARBON 560K 5% 1/4W (D360Z/DE315:E,SP,MY,AUS,CH/DE415)	
R353	1-249-425-11	CARBON 4.7K 5% 1/4W F		R463	1-249-437-11	CARBON 47K 5% 1/4W (D360Z/DE315:E,SP,MY,AUS,CH/DE415)	
R354	1-249-425-11	CARBON 4.7K 5% 1/4W F		R465	1-249-417-11	CARBON 1K 5% 1/4W F	
R355	1-249-425-11	CARBON 4.7K 5% 1/4W F		R466	1-249-417-11	CARBON 1K 5% 1/4W F (D360Z/DE315:E,SP,MY,AUS,CH/DE415)	
R356	1-249-425-11	CARBON 4.7K 5% 1/4W F		R467	1-247-897-11	CARBON 560K 5% 1/4W (D360Z/DE315:E,SP,MY,AUS,CH/DE415)	
R357	1-249-441-11	CARBON 100K 5% 1/4W		R470	1-249-441-11	CARBON 100K 5% 1/4W	
R358	1-249-441-11	CARBON 100K 5% 1/4W		R601	1-249-417-11	CARBON 1K 5% 1/4W F	
R359	1-249-425-11	CARBON 4.7K 5% 1/4W F		R602	1-249-439-11	CARBON 68K 5% 1/4W	
R360	1-249-425-11	CARBON 4.7K 5% 1/4W F (D360Z:CND/DE415:AUS)		R603	1-249-413-11	CARBON 470 5% 1/4W F (DE315:US,CND)	
R360	1-247-843-11	CARBON 3.3K 5% 1/4W (D360Z:US/DE315/DE415:US,CND)		R603	1-249-412-11	CARBON 390 5% 1/4W F (D360Z/DE315:E,SP,MY,AUS,CH/DE415)	
R361	1-249-429-11	CARBON 10K 5% 1/4W		R604	1-249-439-11	CARBON 68K 5% 1/4W	
R362	1-249-429-11	CARBON 10K 5% 1/4W		R605	1-249-441-11	CARBON 100K 5% 1/4W	
R363	1-249-411-11	CARBON 330 5% 1/4W		R610	1-249-421-11	CARBON 2.2K 5% 1/4W F	
R401	1-249-411-11	CARBON 330 5% 1/4W (D360Z/DE315:E,SP,MY,AUS,CH/DE415)		R611	1-249-437-11	CARBON 47K 5% 1/4W	
R402	1-249-421-11	CARBON 2.2K 5% 1/4W F		R613	1-249-414-11	CARBON 560 5% 1/4W F	
R403	1-249-417-11	CARBON 1K 5% 1/4W F		△R614	1-249-409-11	CARBON 220 5% 1/4W F (DE315:SP,MY,CH)	
R404	1-249-417-11	CARBON 1K 5% 1/4W F		△R614	1-249-408-11	CARBON 180 5% 1/4W F (D360Z/DE315:US,CND,E,AUS/DE415)	
R405	1-249-417-11	CARBON 1K 5% 1/4W F		△R615	1-249-409-11	CARBON 220 5% 1/4W F (DE315:SP,MY,CH)	
R406	1-249-417-11	CARBON 1K 5% 1/4W F		△R615	1-249-408-11	CARBON 180 5% 1/4W F (D360Z/DE315:US,CND,E,AUS/DE415)	
R407	1-249-417-11	CARBON 1K 5% 1/4W F		△R616	1-233-352-21	ENCAPSULATED COMPONENT	
R408	1-249-429-11	CARBON 10K 5% 1/4W					
R409	1-249-437-11	CARBON 47K 5% 1/4W (D360Z/DE315:E,SP,MY,AUS,CH/DE415)					
R410	1-247-897-11	CARBON 560K 5% 1/4W (D360Z/DE315:E,SP,MY,AUS,CH/DE415)					
R411	1-249-416-11	CARBON 820 5% 1/4W F (D360Z/DE315:E,SP,MY,AUS,CH/DE415)					
R412	1-247-897-11	CARBON 560K 5% 1/4W (D360Z/DE315:E,SP,MY,AUS,CH/DE415)					

<p>The components identified by mark △ or dotted line with mark △ are critical for safety. Replace only with part number specified.</p>	<p>Les composants identifiés par une marque △ sont critiques pour la sécurité. Ne les remplacer que par une pièce portant le numéro spécifié.</p>
---	---

# MAIN

Ref. No.	Part No.	Description	Remarks	Ref. No.	Part No.	Description	Remarks
△ R617	1-249-393-11	CARBON	10 5% 1/4W F	R724	1-249-429-11	CARBON	10K 5% 1/4W
R618	1-249-389-11	CARBON	4.7 5% 1/4W F	R725	1-249-429-11	CARBON	10K 5% 1/4W
R619	1-249-405-11	CARBON	100 5% 1/4W F	R726	1-249-417-11	CARBON	1K 5% 1/4W F
R620	1-249-419-11	CARBON	1.5K 5% 1/4W F	R727	1-249-427-11	CARBON	6.8K 5% 1/4W F
R621	1-249-426-11	CARBON	5.6K 5% 1/4W	R730	1-249-429-11	CARBON	10K 5% 1/4W
R622	1-249-403-11	CARBON	68 5% 1/4W F	R731	1-247-887-00	CARBON	220K 5% 1/4W
R623	1-249-437-11	CARBON	47K 5% 1/4W				(DE415)
R630	1-249-426-11	CARBON	5.6K 5% 1/4W	R734	1-249-429-11	CARBON	10K 5% 1/4W
R631	1-247-887-00	CARBON	220K 5% 1/4W				(D360Z:CND/DE415)
R632	1-249-426-11	CARBON	5.6K 5% 1/4W	△ R740	1-249-393-11	CARBON	10 5% 1/4W F
			(DE415)	△ R741	1-249-393-11	CARBON	10 5% 1/4W F
R651	1-249-417-11	CARBON	1K 5% 1/4W F	R742	1-249-425-11	CARBON	4.7K 5% 1/4W F
R652	1-249-439-11	CARBON	68K 5% 1/4W	R743	1-249-425-11	CARBON	4.7K 5% 1/4W F
R653	1-249-413-11	CARBON	470 5% 1/4W F	R751	1-249-417-11	CARBON	1K 5% 1/4W F
			(DE315:US,CND)	R752	1-249-439-11	CARBON	68K 5% 1/4W
R653	1-249-412-11	CARBON	390 5% 1/4W F	R753	1-249-413-11	CARBON	470 5% 1/4W F
			(D360Z/DE315:E,SP,MY,AUS,CH/DE415)				(DE315:US,CND)
R654	1-249-439-11	CARBON	68K 5% 1/4W	R753	1-249-412-11	CARBON	390 5% 1/4W F
R655	1-249-441-11	CARBON	100K 5% 1/4W				(D360Z/DE315:E,SP,MY,AUS,CH/DE415)
R660	1-249-421-11	CARBON	2.2K 5% 1/4W F	R754	1-249-439-11	CARBON	68K 5% 1/4W
R661	1-249-437-11	CARBON	47K 5% 1/4W	R755	1-249-441-11	CARBON	100K 5% 1/4W
R663	1-249-414-11	CARBON	560 5% 1/4W F	R760	1-247-897-11	CARBON	560K 5% 1/4W
△ R664	1-249-409-11	CARBON	220 5% 1/4W F				(DE315:E)
			(DE315:SP,MY,CH)	R760	1-249-421-11	CARBON	2.2K 5% 1/4W F
△ R664	1-249-408-11	CARBON	180 5% 1/4W F	R761	1-249-437-11	CARBON	47K 5% 1/4W
			(D360Z/DE315:US,CND,E,AUS/DE415)	R763	1-249-414-11	CARBON	560 5% 1/4W F
△ R665	1-249-409-11	CARBON	220 5% 1/4W F	△ R764	1-249-409-11	CARBON	220 5% 1/4W F
			(DE315:SP,MY,CH)				(DE315:SP,MY,CH)
△ R665	1-249-408-11	CARBON	180 5% 1/4W F	△ R764	1-249-408-11	CARBON	180 5% 1/4W F
			(D360Z/DE315:US,CND,E,AUS/DE415)				(D360Z/DE315:US,CND,E,AUS/DE415)
△ R666	1-233-352-21	ENCAPSULATED COMPONENT		△ R765	1-249-409-11	CARBON	220 5% 1/4W F
△ R667	1-249-393-11	CARBON	10 5% 1/4W F				(DE315:SP,MY,CH)
R668	1-249-389-11	CARBON	4.7 5% 1/4W F	△ R765	1-249-408-11	CARBON	180 5% 1/4W F
R670	1-249-419-11	CARBON	1.5K 5% 1/4W F				(D360Z/DE315:US,CND,E,AUS/DE415)
R671	1-249-426-11	CARBON	5.6K 5% 1/4W	△ R766	1-233-352-21	ENCAPSULATED COMPONENT	
R673	1-249-437-11	CARBON	47K 5% 1/4W	△ R767	1-249-393-11	CARBON	10 5% 1/4W F
R701	1-249-417-11	CARBON	1K 5% 1/4W F	R768	1-249-389-11	CARBON	4.7 5% 1/4W F
R702	1-249-439-11	CARBON	68K 5% 1/4W	R770	1-249-419-11	CARBON	1.5K 5% 1/4W F
R703	1-249-413-11	CARBON	470 5% 1/4W F	R771	1-249-426-11	CARBON	5.6K 5% 1/4W
			(DE315:US,CND)	R773	1-249-437-11	CARBON	47K 5% 1/4W
R703	1-249-412-11	CARBON	390 5% 1/4W F	R781	1-247-887-00	CARBON	220K 5% 1/4W
			(D360Z/DE315:E,SP,MY,AUS,CH/DE415)				(DE415)
R704	1-249-439-11	CARBON	68K 5% 1/4W	△ R803	1-249-389-11	CARBON	4.7 5% 1/4W F
R705	1-249-441-11	CARBON	100K 5% 1/4W				(DE315:SP,MY,CH)
R710	1-249-421-11	CARBON	2.2K 5% 1/4W F	△ R803	1-247-739-11	CARBON	100 5% 1/2W F
R711	1-249-437-11	CARBON	47K 5% 1/4W				(D360Z/DE315:US,CND,E,AUS/DE415)
R713	1-249-414-11	CARBON	560 5% 1/4W F	R804	1-249-421-11	CARBON	2.2K 5% 1/4W F
△ R714	1-249-409-11	CARBON	220 5% 1/4W F				(DE315:SP,MY,CH)
			(DE315:SP,MY,CH)	R804	1-249-425-11	CARBON	4.7K 5% 1/4W F
△ R714	1-249-408-11	CARBON	180 5% 1/4W F				(D360Z/DE315:US,CND,E,AUS/DE415)
			(D360Z/DE315:US,CND,E,AUS/DE415)	R821	1-249-437-11	CARBON	47K 5% 1/4W
△ R715	1-249-409-11	CARBON	220 5% 1/4W F	R822	1-249-425-11	CARBON	4.7K 5% 1/4W F
			(DE315:SP,MY,CH)	R823	1-249-437-11	CARBON	47K 5% 1/4W
△ R715	1-249-408-11	CARBON	180 5% 1/4W F	R824	1-249-425-11	CARBON	4.7K 5% 1/4W F
			(D360Z/DE315:US,CND,E,AUS/DE415)	R825	1-249-407-11	CARBON	150 5% 1/4W F
△ R716	1-233-352-21	ENCAPSULATED COMPONENT					
△ R717	1-249-393-11	CARBON	10 5% 1/4W F				
R718	1-249-389-11	CARBON	4.7 5% 1/4W F				
△ R719	1-249-405-11	CARBON	100 5% 1/4W F				
R720	1-249-419-11	CARBON	1.5K 5% 1/4W F				
R721	1-249-426-11	CARBON	5.6K 5% 1/4W				
△ R722	1-249-403-11	CARBON	68 5% 1/4W F				
R723	1-249-437-11	CARBON	47K 5% 1/4W				

The components identified by mark △ or dotted line with mark △ are critical for safety. Replace only with part number specified.	Les composants identifiés par une marque △ sont critiques pour la sécurité. Ne les remplacer que par une pièce portant le numéro spécifique.
--	--

MAIN

PRIMARY

SECONDARY

SELECTOR

STBY

Ref. No.	Part No.	Description	Remarks
△ R830	1-249-402-11	CARBON 56 5% 1/4W F (D360Z:CND/DE315:CND/DE415:CND)	
△ R830	1-249-405-11	CARBON 100 5% 1/4W F (D360Z:US/DE315:US,E,SP,MY,AUS,CH/DE415:US,AUS)	
△ R831	1-249-402-11	CARBON 56 5% 1/4W F (D360Z:CND/DE315:CND/DE415:CND)	
△ R831	1-249-403-11	CARBON 68 5% 1/4W F (D360Z:US/DE315:US,E,SP,MY,AUS,CH/DE415:US,AUS)	
R950	1-249-421-11	CARBON 2.2K 5% 1/4W F	
R951	1-249-429-11	CARBON 10K 5% 1/4W	
R952	1-247-843-11	CARBON 3.3K 5% 1/4W	
R953	1-249-433-11	CARBON 22K 5% 1/4W	
R954	1-249-439-11	CARBON 68K 5% 1/4W	
R955	1-249-429-11	CARBON 10K 5% 1/4W	
R956	1-247-843-11	CARBON 3.3K 5% 1/4W	
R957	1-249-417-11	CARBON 1K 5% 1/4W F	
R958	1-249-401-11	CARBON 47 5% 1/4W F (D360Z/DE415)	
R960	1-249-429-11	CARBON 10K 5% 1/4W	
R961	1-249-401-11	CARBON 47 5% 1/4W F (DE315)	
		< RELAY >	
RY601	1-515-921-11	RELAY (12V)	
RY701	1-515-921-11	RELAY (12V)	
RY801	1-755-013-11	RELAY (D360Z:US/DE315:US,E,SP,MY,AUS,CH/DE415:US,AUS)	
RY851	1-755-209-11	RELAY (D360Z:CND/DE315:CND/DE415:CND)	
RY852	1-755-209-11	RELAY (D360Z:CND/DE315:CND/DE415:CND)	
		< TERMINAL >	
TM1	1-537-714-11	TERMINAL BOARD (ANTENNA) (DE315:E,SP,MY,AUS,CH/DE415:AUS)	
TM1	1-537-240-51	TERMINAL BOARD (ANTENNA) (D360Z/DE315:US,CND/DE415:US,CND)	
TM601	1-537-510-11	TERMINAL BOARD (6P)(SURROUND SPEAKER)	
TM701	1-537-376-11	TERMINAL BOARD (FRONT SPEAKERS)	
		< TUNER >	
TU001	1-233-594-11	ENCAPSULATED COMPONENT (DE315:E,SP,MY,AUS,CH/DE415:AUS)	
TU001	1-233-593-11	ENCAPSULATED COMPONENT (D360Z/DE315:US,CND/DE415:US,CND)	
		< VIBRATOR >	
X301	1-579-952-21	VIBRATOR, CERAMIC 8MHz	
*****			
*	1-665-273-11	PRIMARY BOARD ***** (D360Z/DE315:US,CND,SP,MY,AUS,CH/DE415)	
	1-533-233-21	HOLDER, FUSE	
		< FUSE >	
△ F901	1-532-388-51	FUSE (T2AL/250V) (DE315:SP,MY,AUS,CH/DE415:AUS)	
△ F901	1-576-109-11	FUSE (5A/250) (D360Z/DE315:US,CND/DE415:US,CND)	
*****			

Ref. No.	Part No.	Description	Remarks
*	1-665-274-11	SECONDARY BOARD *****	
	1-533-233-21	HOLDER, FUSE < CONNECTOR >	
CNP801	1-764-480-11	PIN, CONNECTOR (PC BOARD) 11P < RESISTOR >	
△ R810	1-249-381-11	CARBON 1 5% 1/4W F (EXCEPT CND)	
△ R810	1-219-124-11	FUSE RESISTOR 0.68 1/4W (CND)	
△ R811	1-249-381-11	CARBON 1 5% 1/4W F (EXCEPT CND)	
△ R811	1-219-124-11	FUSE RESISTOR 0.68 5% 1/4W (CND)	
*****			
*	1-665-275-11	SELECTOR BOARD (DE315:E) *****	
	1-533-233-21	HOLDER, FUSE < CONNECTOR >	
* CNP907	1-565-395-11	PIN, CONNECTOR 3P	
* CNP908	1-564-321-00	PIN, CONNECTOR 2P	
* CNP910	1-564-687-11	PIN, CONNECTOR 3P < FUSE >	
△ F904	1-532-388-51	FUSE (T2AL/250V) < SWITCH >	
△ S901	1-571-437-11	SWITCH, POWER (VOLTAGE SELECTOR) *****	
*	1-665-272-11	STBY BOARD ***** < CONNECTOR >	
CN902	1-564-321-00	PIN, CONNECTOR 2P (DE315:E) < JACK >	
△ CNJ902	1-540-057-11	OUTLET, AC (POLAR) (D360Z/DE315:US,CND,E/DE415:US,CND)	
△ CNJ902	1-526-794-11	OUTLET, A.C.(DE315:SP,MY,CH) < CONNECTOR >	
CNP802	1-779-495-11	PLUG, CONNECTOR PIN 4P	
CNP901	1-564-321-00	PIN, CONNECTOR 2P	
CNP903	1-580-230-11	PIN, CONNECTOR (PC BOARD) 2P (DE315:SP,MY,AUS,CH/DE415:AUS)	
CNP905	1-564-320-00	PIN, CONNECTOR (B2P-VH) 2P (DE315:E)	
* CNP906	1-564-687-11	PIN, CONNECTOR 3P (DE315:E) < DIODE >	
D816	8-719-987-63	DIODE 1N4148M	

The components identified by mark △ or dotted line with mark △ are critical for safety. Replace only with part number specified.	Les composants identifiés par une marque △ sont critiques pour la sécurité. Ne les remplacer que par une pièce portant le numéro spécifié.
--	--

**STBY**   **SW**   **VIDEO**   **VR TONE**

Ref. No.	Part No.	Description	Remarks
		< FUSE >	
△ F902	1-532-464-51	FUSE (DE315:SP,MY,CH)	
		< TERMINAL >	
* G900	1-537-738-21	TERMINAL, EARTH	
		< RESISTOR >	
△ R901	1-202-725-00	SOLID            3.3M    10%    1/2W (D360Z/DE315:US,CND/DE415:US,CND)	
		< RELAY >	
△ RY901	1-515-720-11	RELAY	
		< TRANSFORMER >	
△ T902	1-450-361-11	TRANSFORMER, POWER (D360Z/DE315:US,CND/DE415:US,CND)	
△ T902	1-450-358-11	TRANSFORMER, POWER (DE315:E,SP,MY,AUS,CH/DE415:AUS)	
*****			
*	A-4392-789-A	SW BOARD, COMPLETE ***** (Including SW(A) /SW(B) BOARD)	
		< CONNECTOR >	
CNP703	1-764-474-11	PIN, CONNECTOR (PC BOARD) 5P	
CNP704	1-764-473-11	PIN, CONNECTOR (PC BOARD) 3P	
CNS702	1-770-378-11	CONNECTOR, BOARD TO BOARD 5P	
		< JACK >	
J741	1-750-733-11	JACK (LARGE TYPE)(PHONES)	
		< RESISTOR >	
R741	1-247-753-11	CARBON            1.2K    5%    1/2W	
R742	1-247-753-11	CARBON            1.2K    5%    1/2W	
R791	1-247-753-11	CARBON            1.2K    5%    1/2W	
R792	1-247-753-11	CARBON            1.2K    5%    1/2W	
		< SWITCH >	
S701	1-762-319-11	SWITCH, PUSH (2 KEY)(SPEAKERS)	
*****			
*	1-665-271-11	VIDEO BOARD (D360Z/DE415) *****	
*	4-921-941-01	CUSHION (FL)	
*	4-943-107-11	HOLDER (FL TUBE)	
		< CAPACITOR >	
C250	1-126-960-11	ELECT            1uF    20%    50V	
C251	1-126-960-11	ELECT            1uF    20%    50V	
C252	1-164-159-11	CERAMIC            0.1uF            50V	
C253	1-104-664-11	ELECT            47uF    20%    25V	
C254	1-164-159-11	CERAMIC            0.1uF            50V	
C255	1-126-924-11	ELECT            330uF    20%    10V	
C256	1-162-215-31	CERAMIC            47PF    5%    50V	
C257	1-162-215-31	CERAMIC            47PF    5%    50V	
		< CONNECTOR >	
CNS250	1-568-439-11	SOCKET, CONNECTOR 7P	

Ref. No.	Part No.	Description	Remarks
		< DIODE >	
D224	8-719-987-63	DIODE 1N4148M	
		< IC >	
IC251	8-759-333-84	IC NJM2279D	
		< JACK >	
J251	1-695-317-21	JACK, PIN 2P (VIEO/TV DBS)	
J252	1-695-317-21	JACK, PIN 2P (VIEDO/MONITOR)	
J253	1-774-843-11	JACK, PIN 1P (WOOFER)(DE415)	
		< RESISTOR >	
R251	1-247-804-11	CARBON            75      5%    1/4W	
R252	1-247-804-11	CARBON            75      5%    1/4W	
R253	1-247-804-11	CARBON            75      5%    1/4W	
R254	1-247-804-11	CARBON            75      5%    1/4W	
R255	1-249-429-11	CARBON            10K     5%    1/4W	
R256	1-249-429-11	CARBON            10K     5%    1/4W	
R257	1-249-411-11	CARBON            330     5%    1/4W	
*****			
*	A-4392-788-A	VR TONE BOARD, COMPLETE ***** (Including VOLUME BOARD)	
		< CAPACITOR >	
C420	1-162-207-31	CERAMIC            22PF    5%    50V	
C421	1-137-440-11	FILM                0.018uF 5%    50V	
C422	1-124-463-00	ELECT                0.1uF    20%    50V	
C423	1-137-368-11	FILM                0.0047uF 5%    50V	
C424	1-137-372-11	FILM                0.022uF 5%    50V	
C425	1-126-096-11	ELECT                10uF    20%    35V	
C426	1-126-096-11	ELECT                10uF    20%    35V	
C427	1-124-252-00	ELECT                0.33uF 20%    50V	
C428	1-130-489-00	MYLAR                0.033uF 5%    50V	
C429	1-102-973-00	CERAMIC            100PF    5%    50V	
C430	1-126-301-11	ELECT                1uF      20%    50V	
C431	1-126-301-11	ELECT                1uF      20%    50V	
C432	1-126-096-11	ELECT                10uF    20%    35V	
C433	1-126-096-11	ELECT                10uF    20%    35V	
C470	1-162-207-31	CERAMIC            22PF    5%    50V	
C471	1-137-440-11	FILM                0.018uF 5%    50V	
C472	1-124-463-00	ELECT                0.1uF    20%    50V	
C473	1-137-368-11	FILM                0.0047uF 5%    50V	
C474	1-137-372-11	FILM                0.022uF 5%    50V	
C475	1-126-096-11	ELECT                10uF    20%    35V	
C476	1-126-096-11	ELECT                10uF    20%    35V	
C477	1-124-252-00	ELECT                0.33uF 20%    50V	
C478	1-130-489-00	MYLAR                0.033uF 5%    50V	
C479	1-102-973-00	CERAMIC            100PF    5%    50V	
C492	1-124-464-11	ELECT                0.22uF 20%    50V	
C601	1-126-163-11	ELECT                4.7uF    20%    50V	
C651	1-126-163-11	ELECT                4.7uF    20%    50V	
C701	1-126-163-11	ELECT                4.7uF    20%    50V	
C751	1-126-163-11	ELECT                4.7uF    20%    50V	

The components identified by mark △ or dotted line with mark △ are critical for safety. Replace only with part number specified.	Les composants identifiés par une marque △ sont critiques pour la sécurité. Ne les remplacer que par une pièce portant le numéro spécifié.
--	--



Ref. No.	Part No.	Description	Remarks	Ref. No.	Part No.	Description	Remarks
		< CONNECTOR >				< SWITCH >	
CNP202	1-770-391-11	PIN, CONNECTOR (PC BOARD) 7P		S240	1-762-751-11	SWITCH, TACTILE (BASS BOOST)	
CNS402	1-568-439-11	SOCKET, CONNECTOR 7P		*****			
CNS403	1-568-442-11	SOCKET, CONNECTOR 9P				MISCELLANEOUS	
		< DIODE >				*****	
D238	8-719-313-50	DIODE SEL6810A-TH12 (BASS BOOST)		10	1-782-084-11	WIRE (FLAT TYPE) (23 CORE) (D360Z/DE315:US,CND,E,AUS/DE415)	
D421	8-719-987-63	DIODE 1N4148M		11	1-782-075-11	WIRE (FLAT TYPE) (9 CORE)	
		< IC >		12	1-782-074-11	WIRE (FLAT TYPE) (7 CORE)	
IC404	8-759-636-74	IC M5218AP-22		53	1-769-746-61	LEAD (WITH CONNECTOR) (2 CORE)(DE315:E)	
		< TRANSISTOR >		61	1-782-086-11	WIRE (FLAT TYPE) (27 CORE)(DE315:SP,MY,CH)	
Q401	8-729-202-67	TRANSISTOR 2SK246-GR3		△71	1-696-847-11	CORD, POWER (AUS)	
Q402	8-729-141-30	TRANSISTOR 2SC3623A-LK		△71	1-777-070-11	CORD, POWER (US,CND)	
Q451	8-729-202-67	TRANSISTOR 2SK246-GR3		△71	1-777-071-11	CORD, POWER (E,SP,MY,CH)	
Q452	8-729-141-30	TRANSISTOR 2SC3623A-LK		△72	1-569-008-21	ADAPTOR, CONVERSION 2P (E)	
		< RESISTOR >		△CNJ903	1-251-416-11	OUTLET, A.C.(AUS)	
R420	1-249-415-11	CARBON 680 5% 1/4W F		△CNJ903	1-526-794-11	OUTLET, A.C.(SP,MY,CH)	
R421	1-249-430-11	CARBON 12K 5% 1/4W		△T901	1-431-258-11	TRANSFORMER, POWER (DE315:US)	
R422	1-249-422-11	CARBON 2.7K 5% 1/4W F		△T901	1-431-259-11	TRANSFORMER, POWER (DE315:CND)	
R423	1-247-903-00	CARBON 1M 5% 1/4W		△T901	1-431-260-11	TRANSFORMER, POWER (DE315:SP,MY,CH)	
R424	1-247-903-00	CARBON 1M 5% 1/4W		△T901	1-431-261-11	TRANSFORMER, POWER (DE315:AUS)	
R425	1-249-429-11	CARBON 10K 5% 1/4W		△T901	1-431-262-11	TRANSFORMER, POWER (DE315:E)	
R426	1-249-439-11	CARBON 68K 5% 1/4W		△T901	1-431-263-11	TRANSFORMER, POWER (DE360Z:US/DE415:US)	
R427	1-249-417-11	CARBON 1K 5% 1/4W F		△T901	1-431-264-11	TRANSFORMER, POWER (D360Z:CND/DE415:CND)	
R430	1-249-437-11	CARBON 47K 5% 1/4W		△T901	1-431-265-11	TRANSFORMER, POWER (DE415:AUS)	
R431	1-247-843-11	CARBON 3.3K 5% 1/4W		*****			
R432	1-247-883-00	CARBON 150K 5% 1/4W				ACCESSORIES & PACKING MATERIALS	
R433	1-249-427-11	CARBON 6.8K 5% 1/4W F				*****	
R434	1-249-413-11	CARBON 470 5% 1/4W F		1-475-136-11		REMOTE COMMANDER (RM-U301)	
R438	1-249-441-11	CARBON 100K 5% 1/4W		1-501-594-11		ANTENNA (FM)(DE315:SP,MY,AUS,CH/DE415:AUS)	
R441	1-249-441-11	CARBON 100K 5% 1/4W		1-501-659-11		ANTENNA (FM) (D360Z/DE315:US,CND/DE415:US)	
R444	1-247-903-00	CARBON 1M 5% 1/4W		1-501-721-11		ANTENNA (LOOP)	
R464	1-247-903-00	CARBON 1M 5% 1/4W		3-859-657-21		MANUAL, INSTRUCTION (ENGLISH) (D360Z:US/DE315:US,AUS/DE415:US,AUS)	
R469	1-247-903-00	CARBON 1M 5% 1/4W		3-859-657-31		MANUAL, INSTRUCTION (ENGLISH/FRENCH) (D360Z:CND/DE315:CND/DE415:CND)	
R470	1-249-415-11	CARBON 680 5% 1/4W F		3-859-657-61		MANUAL, INSTRUCTION (ENGLISH/FRENCH/SPANISH/CHINESE) (DE315:E,SP,MY,CH)	
R471	1-249-430-11	CARBON 12K 5% 1/4W		4-981-643-01		COVER, BATTERY (FOR RM-U301)	
R472	1-249-422-11	CARBON 2.7K 5% 1/4W F		*****			
R473	1-247-903-00	CARBON 1M 5% 1/4W				*****	
R474	1-247-903-00	CARBON 1M 5% 1/4W				HARDWARE LIST	
R475	1-249-429-11	CARBON 10K 5% 1/4W				*****	
R476	1-249-439-11	CARBON 68K 5% 1/4W		#1	7-685-646-79	SCREW +BVTP 3X8 TYPE2 IT-3	
R477	1-249-417-11	CARBON 1K 5% 1/4W F		#2	7-685-880-09	SCREW +BVTT 4X8 (S)	
R480	1-249-437-11	CARBON 47K 5% 1/4W		#3	7-685-872-09	SCREW +BVTT 3X8 (S)	
R481	1-247-843-11	CARBON 3.3K 5% 1/4W		#4	7-685-646-71	SCREW +BTP 3X8	
R482	1-247-883-00	CARBON 150K 5% 1/4W					
R483	1-249-427-11	CARBON 6.8K 5% 1/4W F					
R484	1-249-413-11	CARBON 470 5% 1/4W F					
R491	1-249-441-11	CARBON 100K 5% 1/4W					
R492	1-247-903-00	CARBON 1M 5% 1/4W					
R494	1-247-903-00	CARBON 1M 5% 1/4W					
		< VARIABLE RESISTOR >					
RV404	1-225-229-11	RES, VAR, CARBON 100KX4 (MASTER VOLUME)					
RV421	1-223-362-11	RES, VAR, CARBON 100K/100K (BASS)					
RV422	1-223-363-11	RES, VAR, CARBON 125K/125K (TREBLE)					
RV423	1-225-447-11	RES, VAR, CARBON 100K/100K (BALANCE)					

The components identified by mark △ or dotted line with mark △ are critical for safety. Replace only with part number specified.	Les composants identifiés par une marque △ sont critiques pour la sécurité. Ne les remplacer que par une pièce portant le numéro spécifié.
--	--

