

STR-D350Z/D450Z/DE405/DE505

SERVICE MANUAL

US Model
Canadian Model

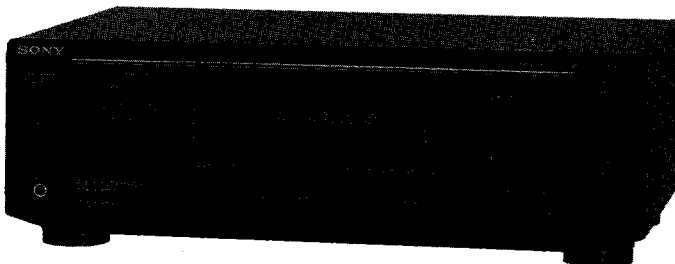



Photo : STR-DE505

Manufactured under license from Dolby Laboratories Licensing Corporation. Additionally licensed under Canadian patent number 1,037,877. "Dolby", the double-D symbol  and "Pro Logic" are trademarks of Dolby Laboratories Licensing Corporation.

Audio power specifications

POWER OUTPUT AND TOTAL HARMONIC DISTORTION

US Model :

With 8-ohm load, both channels driven, from 20 - 20,000 Hz, rated 100 watts (STR-DE505/D450Z), 80 watts (STR-DE405) or 60 watts (STR-D350Z) per channel minimum RMS power, with no more than 0.09 % total harmonic distortion from 150 milliwatts to rated output.

Canadian Model :

20 - 20,000 Hz 0.09%
100W+100W (STR-D450Z, DE505)
20 - 20,000 Hz 0.09%
70W+70W (STR-D350Z, DE405)

SPECIFICATIONS

Amplifier section

Surround mode (8 ohms at 1 kHz, THD 0.8 %)
Front:
STR-DE505/D450Z:
100 W/ch
STR-DE405:
US model : 80W/ch
Canadian model : 70W/ch
STR-D350Z:
US model : 60W/ch
Canadian model : 70W/ch
Center:
STR-DE505/D450Z:
100 W
STR-DE405:
US model : 80W
Canadian model : 70W
STR-D350Z:
US model : 60W
Canadian model : 70W
(only in the PRO LOGIC mode)
Rear:
STR-DE505/D450Z:
100 W
STR-DE405:
US model : 80W
Canadian model : 70W
STR-D350Z:
US model : 60W
Canadian model : 70W
PHONO: RIAA equalization curve ± 0.5 dB
CD, TAPE/MD, VIDEO: 10 Hz - 50 kHz ± 1 dB

Frequency response

Inputs

	Sensitivity	Impedance	S/N (weighting network, input level)
PHONO (MM)	2.5 mV	50 kilohms	74 dB 72 dB* (A, 2.5 mV)
CD	200 mV		
TAPE/MD, TV/DBS, VIDEO	150 mV	50 kilohms	82dB 82dB* (A, 150mV)

* '78 IHF

Outputs

TAPE/MD REC OUT:
Voltage 150 mV,
Impedance 10 kilohms
VIDEO AUDIO OUT:
Voltage 150 mV,
Impedance 10 kilohms
MIX AUDIO OUT
(STR-DE505 only)
Voltage: 2 V
Impedance: 10 kilohms
PHONES: Accepts low and high impedance headphones

— Continued on page 2 —

FM STEREO/FM-AM RECEIVER
SONY



Muting	Full mute	Usable sensitivity	50 dB/m (at 1,000 kHz or 999 kHz)	Power requirements	120 V AC, 60 Hz
BASS BOOST	+10 dB at 70 Hz				
TONE	±8 dB at 100 Hz and 10 kHz	S/N	54 dB (at 50 mV/m)	Power consumption	STR-DE505/D450Z US model : 200W Canadian model : 295VA
FM tuner section		Harmonic distortion	0.5 % (50 mV/m, 400 kHz)		STR-DE405 US model : 165W Canadian model : 225VA
Tuning range	87.5 - 108.0 MHz	Selectivity	At 9 kHz: 35 dB At 10 kHz: 40 dB		STR-D350Z US model : 150W Canadian model : 225VA
Antenna terminals	75 ohms, unbalanced 300 ohms, unbalanced	** You can change the AM tuning interval to 9 kHz. After tuning in any AM station, turn off the receiver. Hold down the TUNING + button and press the POWER button. All preset stations will be erased when you change the interval. To reset the interval to 10 kHz, repeat the procedure.		AC outlets	1 switched, total 120 W / 1A Max
Sensitivity	Mono: 18.3 dBf, 4.5 μV Stereo: 38.3 dBf, 45 μV			Dimensions	430 x 148 x 295 mm (17 x 5 7/8 x 11 3/4 inches)
Usable sensitivity	11.2 dBf, 2 μV (IHF)	Video section		Mass (Approx.)	STR-DE505/D450Z: 7.3 kg (16 lb 1 oz) STR-DE405/D350Z: 6.5 kg (14 lb 5 oz)
S/N	Mono: 76 dB Stereo: 70 dB	Inputs	VIDEO, TV/DBS: 1 Vp-p 75 ohms	Supplied accessories	FM wire antenna (1) AM loop antenna (1) Remote controller (remote) (1) Size AA (R6) batteries (2)
Harmonic distortion at 1 kHz	Mono: 0.3 % Stereo: 0.5 %	Outputs	VIDEO: 1 Vp-p 75 ohms MONITOR: 1 Vp-p 75 ohms	Design and specifications are subject to change without notice.	
Separation	45 dB at 1 kHz	General System	Tuner section: PLL quartz-locked digital synthesizer system Preamplifier section: Low-noise NF type equalizer Power amplifier section: Pure-complimentary SEPP		
Frequency response	30 Hz - 15 kHz ^{+0.5} dB				
Selectivity	60 dB at 400 kHz				
AM tuner section					
Tuning range	With 10 kHz interval**: 530 - 1710 kHz With 9 kHz interval: 531 - 1710 kHz				
Antenna	Loop antenna				

TABLE OF CONTENTS

<i>Section</i>	<i>Title</i>	<i>Page</i>
	specifications	1
1. GENERAL		
	Location and Function of controls	4
2. EXPLANATION OF IC TERMINALS		6
3. DIAGRAMS		
	3-1. Circuit Boards Location	8
	3-2. Printed Wiring Boards (Main Section)	9
	3-3. Schematic Diagram (Main Section)	13
	3-4. Schematic Diagram (Display Section)	18
	3-5. Printed Wiring Boards (Display Section)	21
4. EXPLODED VIEWS		
	4-1. Front panel Section	24
	4-2. Chassis Section	25
5. ELECTRICAL PARTS LIST		26

SAFETY CHECK-OUT

After correcting the original service problem, perform the following safety check before releasing the set to the customer:

Check the antenna terminals, metal trim, "metallized" knobs, screws, and all other exposed metal parts for AC leakage. Check leakage as described below.

LEAKAGE TEST

The AC leakage from any exposed metal part to earth ground and from all exposed metal parts to any exposed metal part having a return to chassis, must not exceed 0.5 mA (500 microampers). Leakage current can be measured by any one of three methods.

1. A commercial leakage tester, such as the Simpson 229 or RCA WT-540A. Follow the manufacturers' instructions to use these instruments.
2. A battery-operated AC milliammeter. The Data Precision 245 digital multimeter is suitable for this job.

3. Measuring the voltage drop across a resistor by means of a VOM or battery-operated AC voltmeter. The "limit" indication is 0.75 V, so analog meters must have an accurate low-voltage scale. The Simpson 250 and Sanwa SH-63Trd are examples of a passive VOM that is suitable. Nearly all battery operated digital multimeters that have a 2 V AC range are suitable. (See Fig. A)

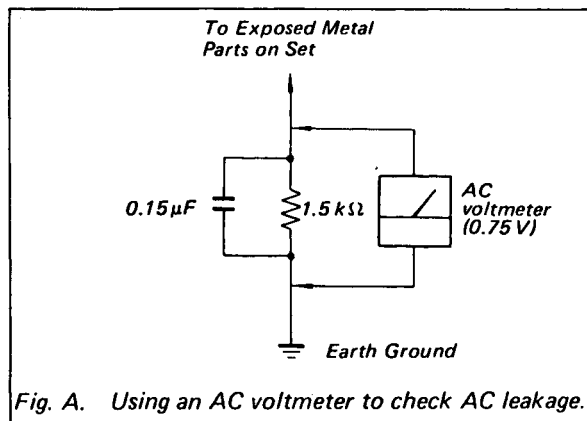





Fig. A. Using an AC voltmeter to check AC leakage.

SAFETY-RELATED COMPONENT WARNING!!

COMPONENTS IDENTIFIED BY MARK  OR DOTTED LINE WITH MARK  ON THE SCHEMATIC DIAGRAMS AND IN THE PARTS LIST ARE CRITICAL TO SAFE OPERATION. REPLACE THESE COMPONENTS WITH SONY PARTS WHOSE PART NUMBERS APPEAR AS SHOWN IN THIS MANUAL OR IN SUPPLEMENTS PUBLISHED BY SONY.

ATTENTION AU COMPOSANT AYANT RAPPORT À LA SÉCURITÉ!

LES COMPOSANTS IDENTIFIÉS PAR UNE MARQUE  SUR LES DIAGRAMMES SCHÉMATIQUES ET LA LISTE DES PIÈCES SONT CRITIQUES POUR LA SÉCURITÉ DE FONCTIONNEMENT. NE REMPLACER CES COMPOSANTS QUE PAR DES PIÈCES SONY DONT LES NUMÉROS SONT DONNÉS DANS CE MANUEL OU DANS LES SUPPLÉMENTS PUBLIÉS PAR SONY.

SECTION 1 GENERAL

LOCATION AND FUNCTION OF CONTROLS

[FRONT PANEL]

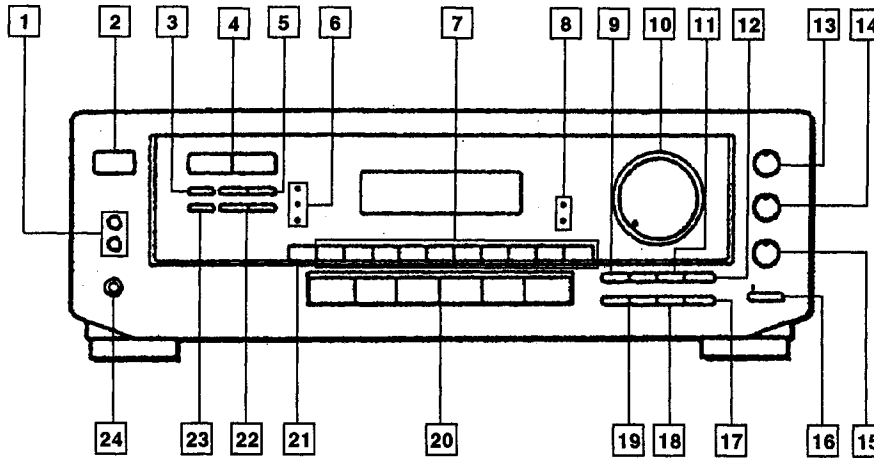

- | | | |
|---|---------------------------------------|------------------------------------|
| 1 SPEAKERS switches | 9 PRESET TUNING +, - buttons | 18 FM/AM button |
| 2 POWER switch | 10 MASTER VOLUME control | 19 TUNING +, - buttons |
| 3 CENTER MODE button | 11 SHIFT button | 20 FUNCTION buttons |
| 4 SURROUND ON/OFF, MODE buttons | 12 FM MODE button | 21 DIRECT button |
| 5 CENTER LEVEL +, - buttons | 13 BASS control | 22 REAR LEVEL +, - buttons |
| 6 PROLOGIC, THEATER, HALL indicators | 14 TREBLE control | 23 DELAY TIME/EFFECT button |
| 7 Numeric button | 15 BALANCE control | 24 PHONES jack |
| 8 VIDEO, TV/DBS indicators | 16 BASS BOOST button/indicator | |
| | 17 MEMORY button | |

[REAR PANEL]

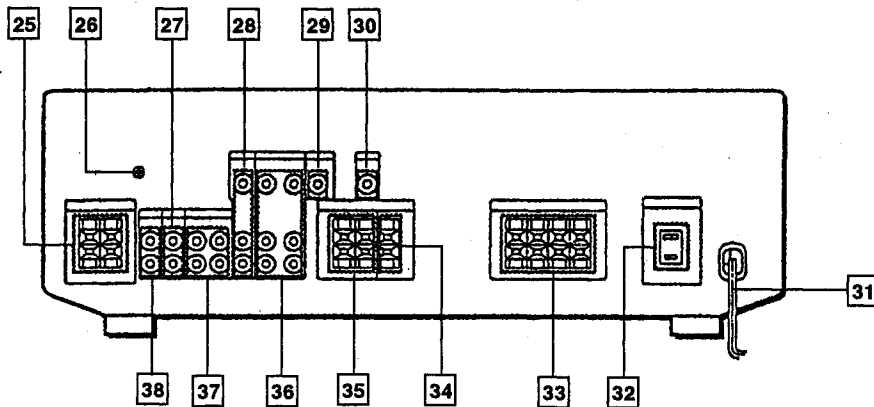

- | | | |
|---------------------------|--|-----------------------------------|
| 25 ANTENNA (AM/FM) | 30 MIX AUDIO OUT (STR-DE505 only) | 35 SURROUND SPEKERS (REAR) |
| 26 ground terminal | 31 AC power cord | 36 VIDEO |
| 27 CD | 32 SWITCHED AC OUTLET | 37 TAPE/MD |
| 28 TV/DBS | 33 FRONT SPEAKERS (A/B) | 38 PHONO |
| 29 MONITOR | 34 SURROUND SPEKER (CENTER) | |

[Remote]

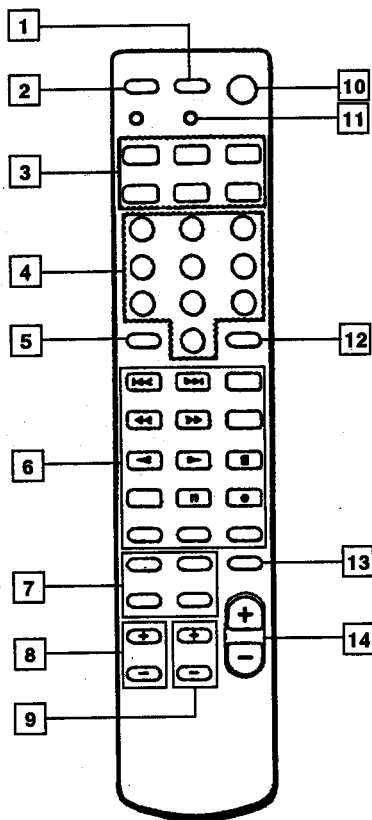

- | | |
|-----------------------------------|---|
| 1 VISUAL POWER button | 8 REAR LEVEL +, - buttons |
| 2 TV control button | 9 CENTER LEVEL +, - buttons |
| 3 FUNCTION buttons | 10 SYSTEM OFF button |
| 4 Numeric buttons | 11 LEARN button/indicator (DE505 : Canadian model) |
| 5 >10/SHIFT button | 12 ENTER button |
| 6 TV/Deck control buttons | 13 MUTING button |
| 7 SURROUND control buttons | 14 MASTER VOLUME +/- buttons |

SECTION 2 EXPLANATION OF IC TERMINALS

IC201 (μ PD78044AGF-165-3B9)

Pin No.	Pin name	I/O	Description
1	DIG7	O	Fluorescent indicator tube drive.
2	DIG6	O	
3	DIG5	O	
4	DIG4	O	
5	DIG3	O	
6	DIG2	O	
7	DIG1	O	
8	+5V	-	Power supply. (+5V)
9	$\overline{S. CLK}$	I	System clock.
10	$\overline{S. DATA}$	I	System data.
11	$\overline{PLL. DATA}$	I	PLL data input from TU001.
12	S. CE (LC7288)	O	Chip enable output.
13	$\overline{S. CE (LV100)}$	I	Chip enable input.
14	VERISON	I	Input for model select.
15	$\overline{PROTECT}$	I	Protector detect input.
16	BRIDGE	O	Standby relay ON/OFF control.
17	\overline{RESET}	I	System reset terminal.
18	$\overline{AUTO-STOP}$	I	Auto stop detect input.
19	$\overline{STEREO-IN}$	I	Stereo detect input.
20	AVss	-	Ground.
21	SP-RY	O	Speaker relay drive.
22	SURR-RY	-	Not used. (Open)
23	POWER-RY	O	Power relay drive.
24	DOWN	O	Volume down control.
25	UP	O	Volume up control.
26	SIGNAL	I	A/D signal input terminal.
27	A/D2	I	A/D2 key input terminal.
28	A/D1	I	A/D1 key input terminal.
29	AVDD	-	Power supply. (+5V)
30	AV. REF	-	Reference voltage. (+5V)
31	GND	-	Ground.
32	NC	-	Not used. (Open)
33	Vss	-	Ground.
34	X1	-	System clock. (4.19MHz)
35	X2	-	System clock. (4.19MHz)
36	IC. MUTE	O	Mute drive output for μ PD2581V (IC701).
37	$\overline{PROLOGIC}$	-	Plologic LED drive.
38	$\overline{SIMULATED}$	-	Theater LED drive.
39	\overline{HALL}	-	Hall LED drive.
40	T. MUTE	O	Tuner mute drive output.

Pin No.	Pin name	I/O	Description
41	$\overline{\text{VIDEO}}$	-	Video LED drive.
42	$\overline{\text{TV/LD}}$	-	TV/DBS LED drive.
43	$\overline{\text{STANDBY}}$	-	Standby LED drive.
44	$\overline{\text{SYS. POWER}}$	I	System power ON/OFF.
45	RDS. DATA. IN	-	Not used. (Open)
46	RDS. CLK. IN	-	Not used. (Open)
47	$\overline{\text{STOP}}$	I	Stop signal input from NJM2103D (IC950).
48	Vss	-	Ground.
49	$\overline{\text{SIRCS}}$	I	Sircs signal input.
50	$\overline{\text{POWER SW}}$	I	Power switch input terminal.
51	NC	-	Ground.
52	+5V	-	Power supply. (+5V)
53	LOW BOOST	-	Bass boost LED drive.
54	FUNC. MUTE	O	Line mute drive.
55	NC	-	Ground.
56	KI5	I	Key in 5.
57	KI4	I	Key in 4
58	KI3	I	Key in 3
59	KI2	I	Key in 2
60	KI1	I	Key in 1.
61	- 20DB	-	Connect to ground.
62	S15	O	Key out 15.
63	S14	O	Key out 14.
64	S13	O	Key out 13.
65	S12	O	Key out 12.
66	S11	O	Key out 11.
67	S10	O	Key out 10.
68	S9	O	Key out 9.
69	S8	O	Key out 8.
70	S7	O	Key out 7.
71	VLOAD	-	Connect to ground.
72	S6	O	Key out 6.
73	S5	O	Key out 5.
74	S4	O	Key out 4.
75	S3	O	Key out 3.
76	S2	O	Key out 2.
77	S1	O	Key out 1.
78	DIG10	O	Fluorescent indicator tube drive.
79	DIG9	O	
80	DIG8	O	

SECTION 3 DIAGRAMS

3-1. CIRCUIT BOARDS LOCATION

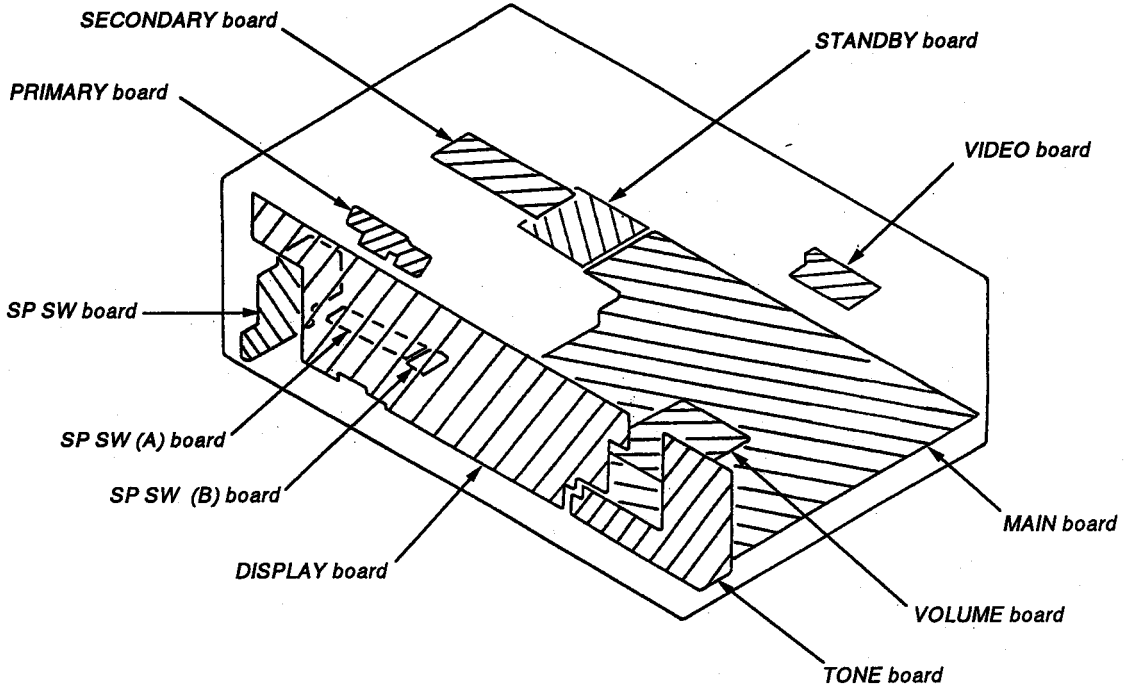

● SEMICONDUCTOR LOCATION

Ref. No.	Location	Ref. No.	Location
D421	G-4	Q308	H-6
D610	C-11	Q401	G-2
D710	J-16	Q402	G-2
D721	H-10	Q451	G-3
D722	H-10	Q452	G-3
D723	I-10	Q601	D-12
D724	H-10	Q602	C-13
D725	I-10	Q603	D-13
D801	I-10	Q604	C-13
D802	F-16	Q610	C-11
D804	J-11	Q620	D-12
D805	J-12	Q651	G-12
D810	C-17	Q652	G-13
D811	C-17	Q653	H-13
D812	C-17	Q654	G-13
D813	C-17	Q670	G-12
D814	C-16	Q701	I-12
D815	C-16	Q702	I-13
D816	E-25	Q703	I-13
D817	F-10	Q704	H-13
D818	D-17	Q710	J-16
D820	D-17	Q720	H-12
D821	D-17	Q721	H-10
D822	D-16	Q722	H-10
D823	D-16	Q723	I-10
IC251	D-3	Q740	I-11
IC252	D-1	Q741	I-11
IC300	H-8	Q751	F-12
IC301	G-8	Q752	E-13
IC302	G-7	Q753	F-13
IC401	D-8	Q754	E-13
IC402	C-7	Q770	E-12
IC404	H-2	Q801	I-11
IC701	H-11	Q802	C-18
IC702	D-11	Q803	J-12
IC801	E-10	Q808	F-10
IC802	E-10	Q809	E-17
IC950	B-14	Q951	B-15
Q303	H-6		
Q304	G-6		
Q307	G-6		

Note:

- : parts extracted from the component side.
- ▨ : Pattern on the side which is seen.
- Abbreviation
CND: Canadian

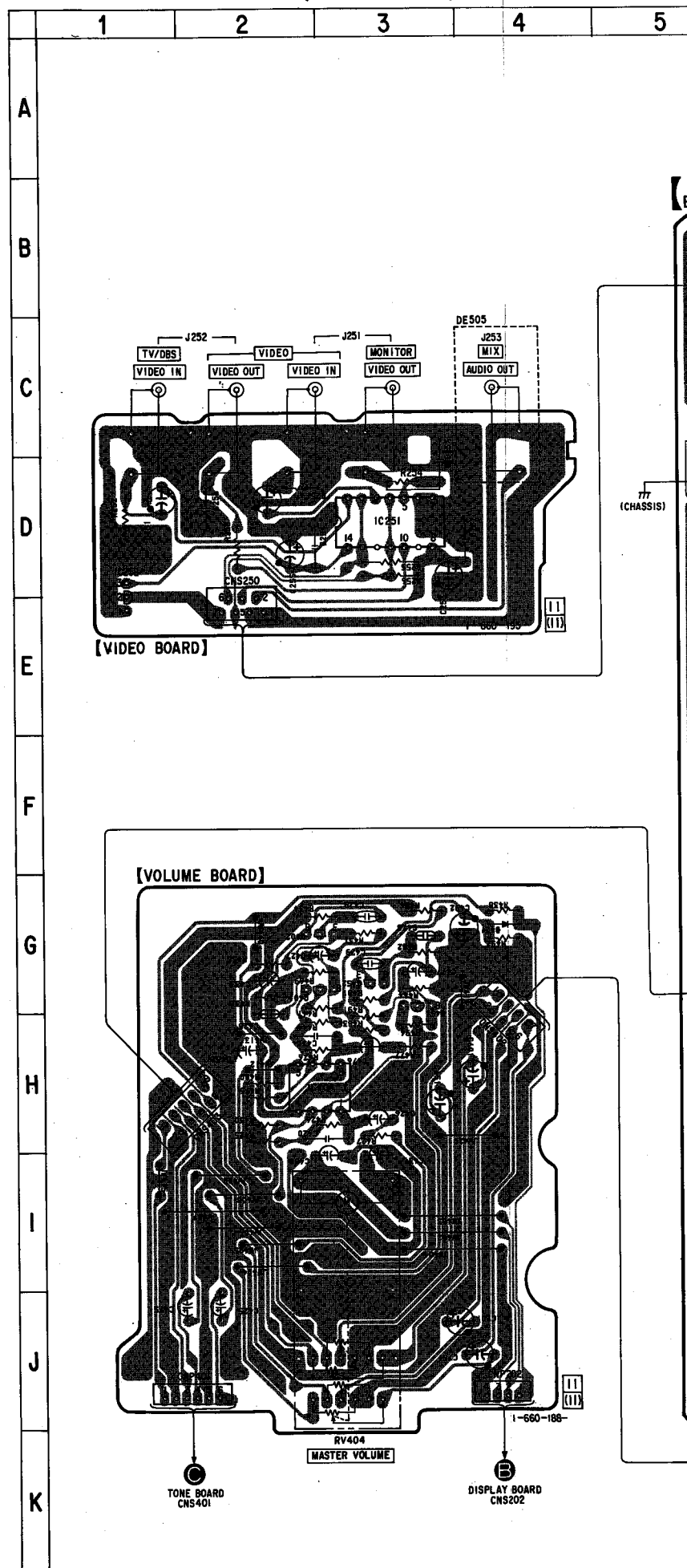

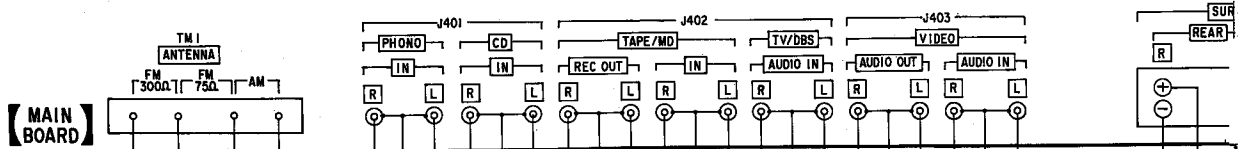

MAIN BOARD

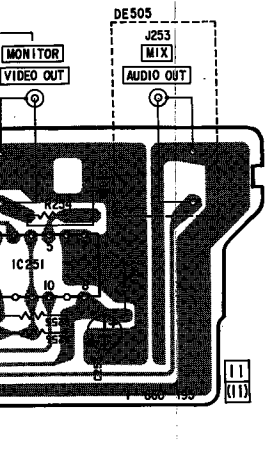

11 (11)

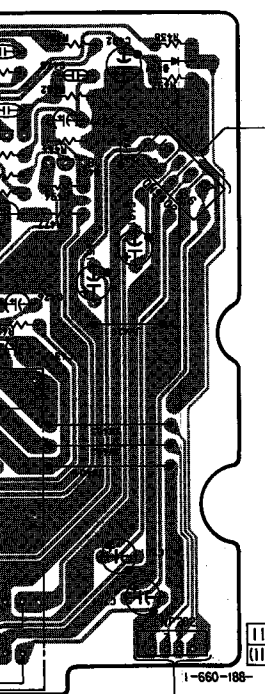

11 (11)

LUME

DISPLAY BOARD CNS202

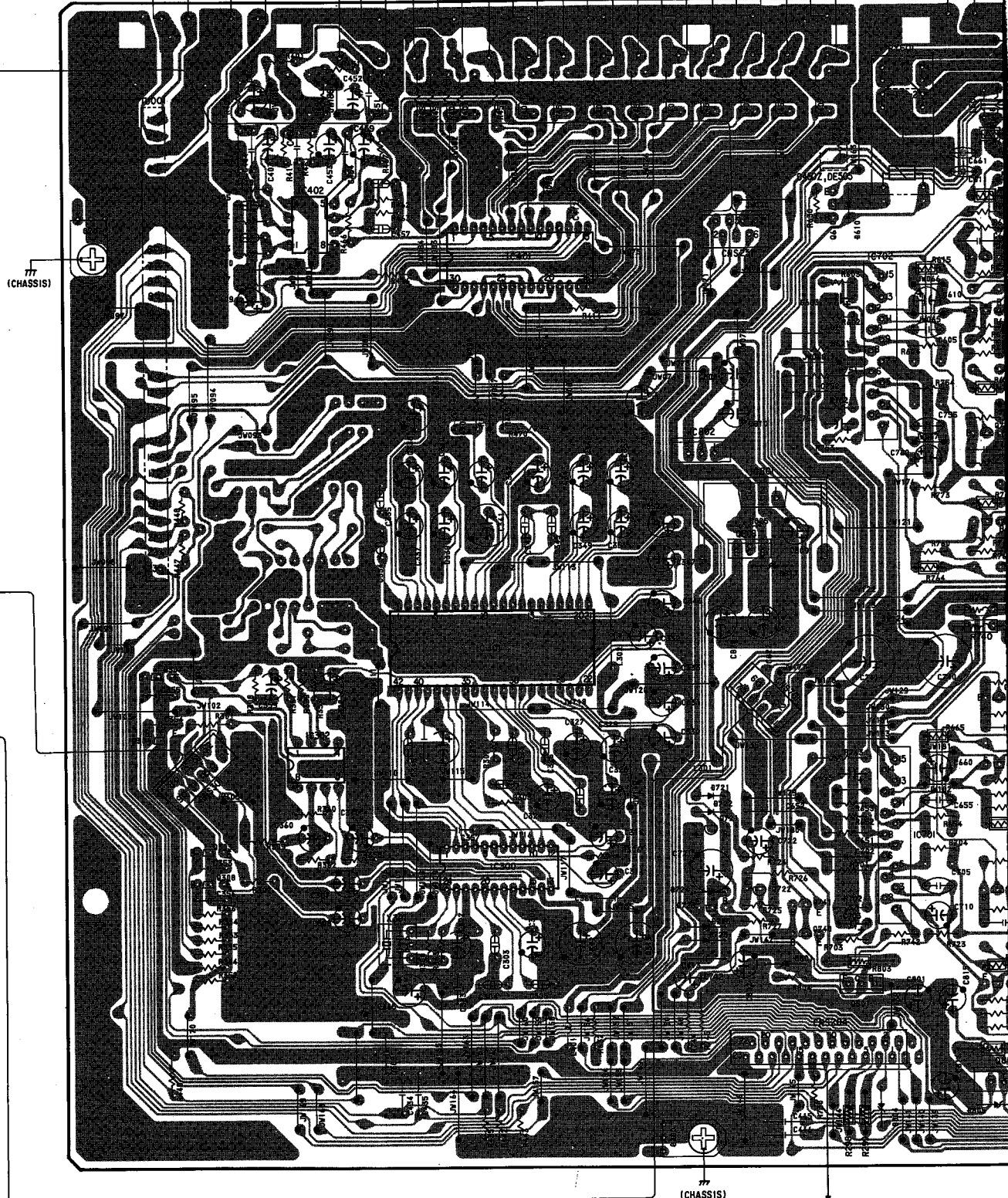

(CHASSIS)

DISPLAY BOARD CNS201

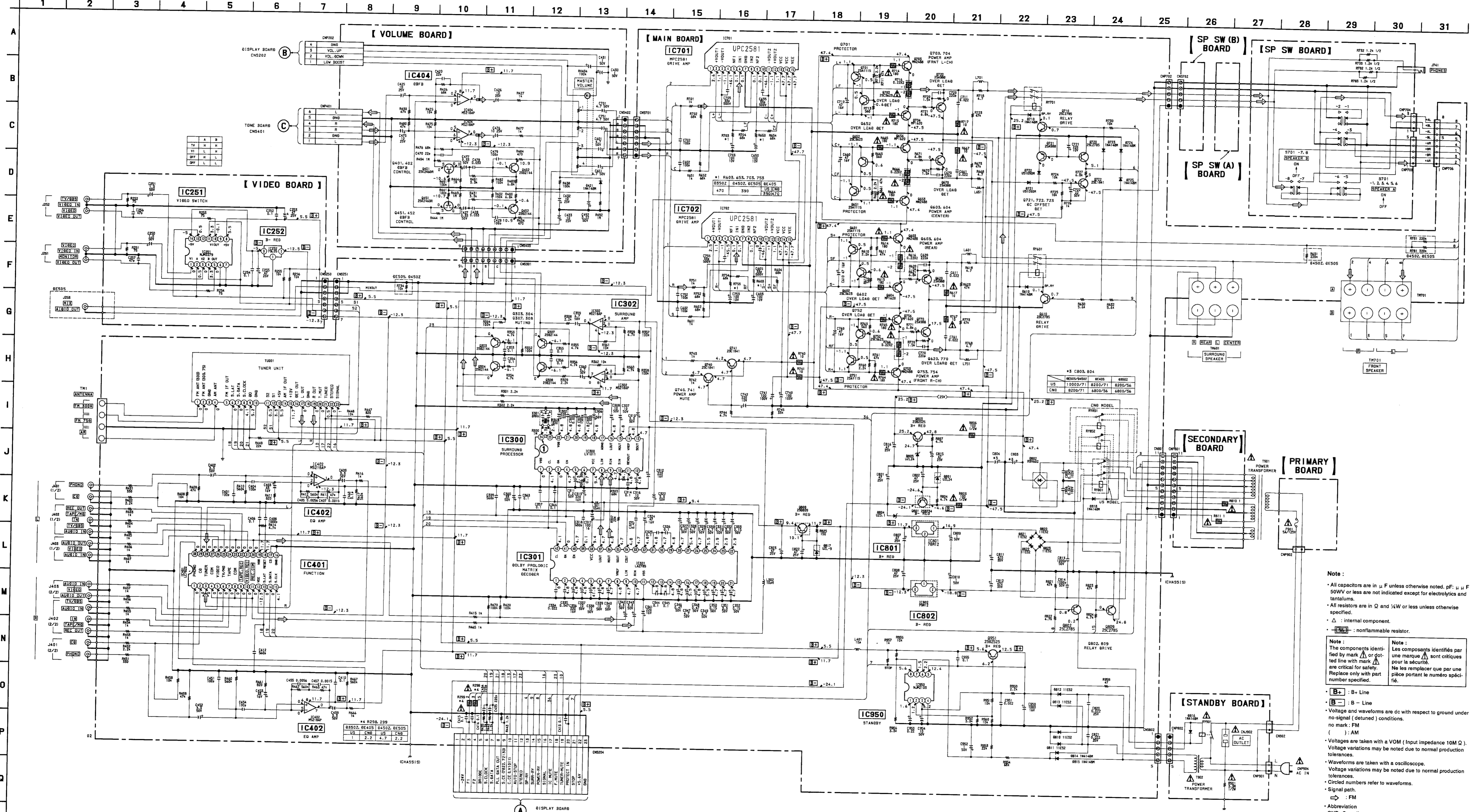

Note :

- All capacitors are in μ F unless otherwise noted. pF, μ F 50V or less are not indicated except for electrolytics and tantalums.
- All resistors are in Ω and $\frac{1}{2}W$ or less unless otherwise specified.
- Δ : internal component.
- \square : nonflammable resistor.

Note :

The components identified by mark Δ or dotted line with mark Δ are critical for safety. Replace only with part number specified.

Note :

Les composants identifiés par une marque Δ sont critiques pour la sécurité. Ne les remplacer que par une pièce portant le numéro spécifié.

- B+ : B+ Line
- B- : B- Line
- Voltage and waveforms are dc with respect to ground under no-signal (detuned) conditions.
- no mark, FM
- () : AM
- Voltages are taken with a VOM (Input impedance 10M Ω). Voltage variations may be noted due to normal production tolerances.
- Waveforms are taken with an oscilloscope. Voltage variations may be noted due to normal production tolerances.
- Circled numbers refer to waveforms.
- Signal path.
- \rightarrow : FM
- Abbreviation
- CND: Canadian

IC BLOCK DIAGRAMS - MAIN SECTION -

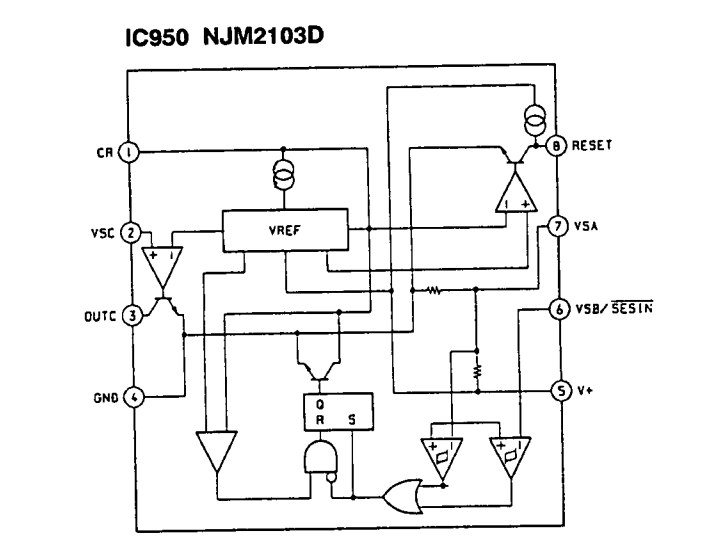
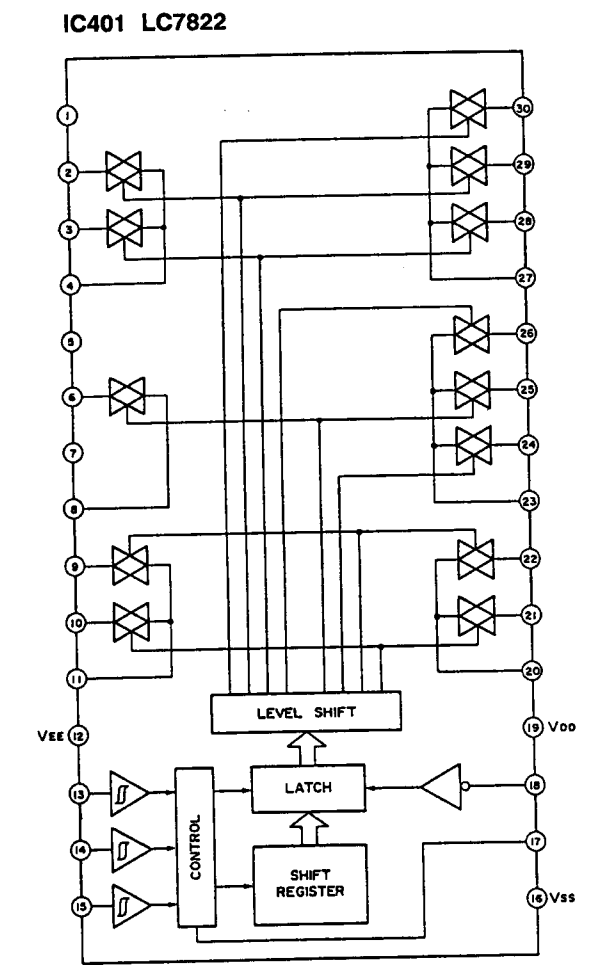
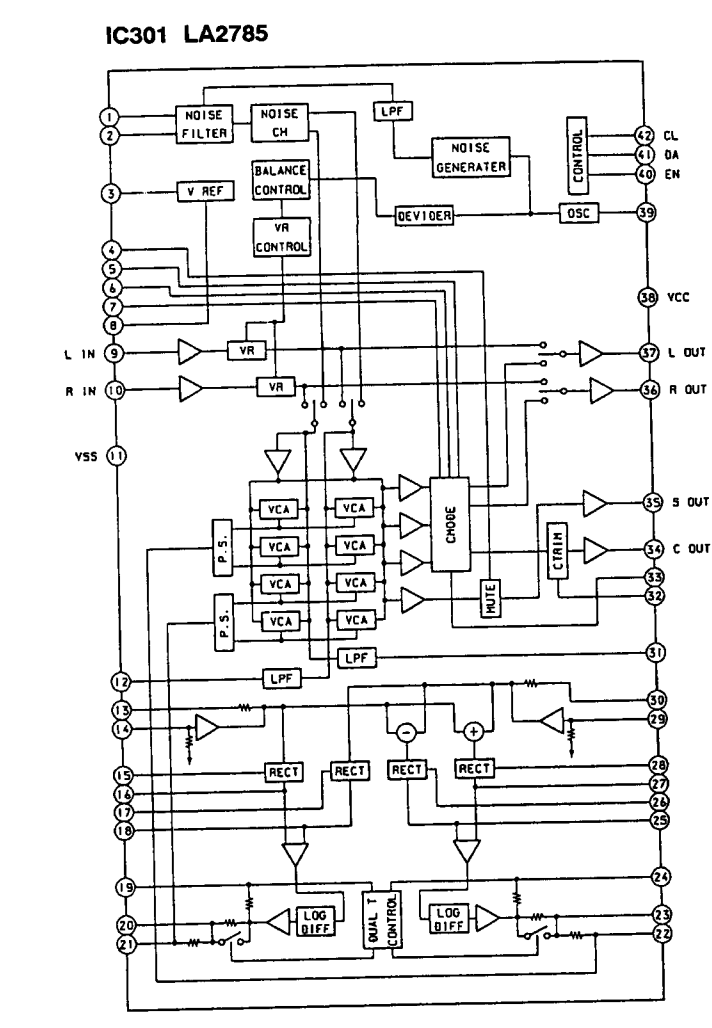
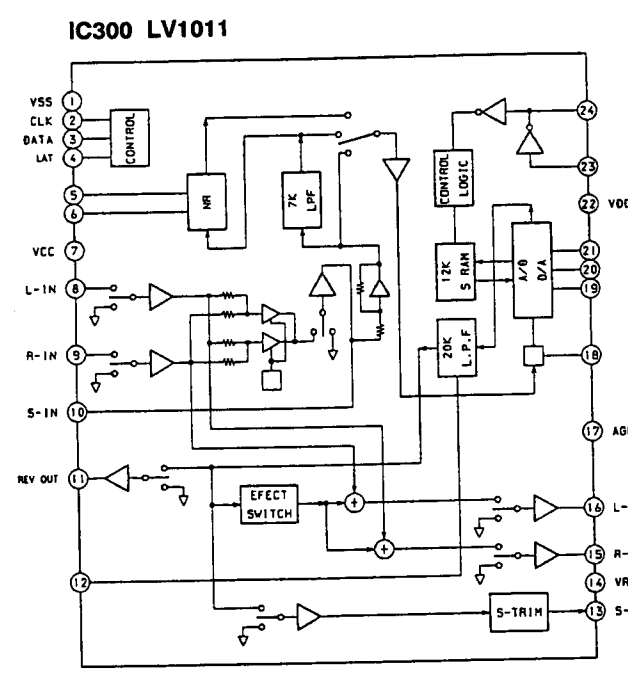
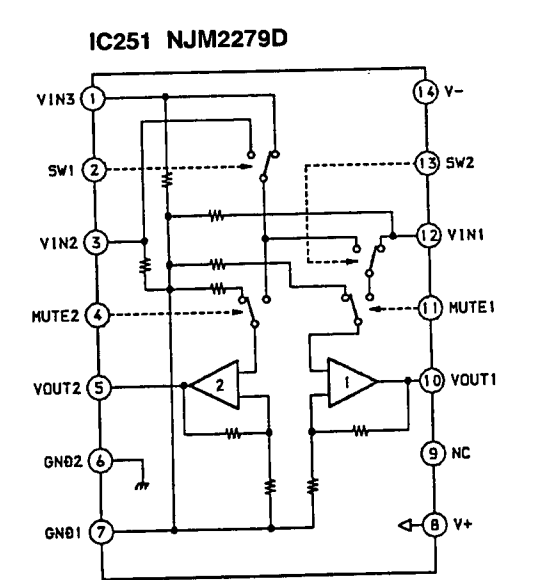

WAVEFORM

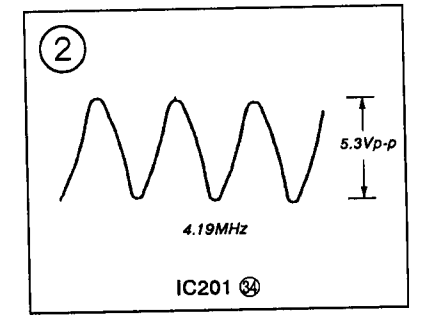

IC BLOCK DIAGRAM - DISPLAY SECTION - IC202 BA6208

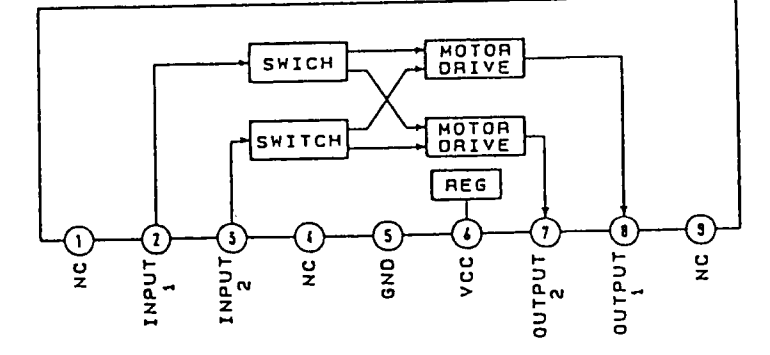

Note: All capacitors are in uF unless otherwise noted. pF: uF 50WV or less are not indicated except for electrolytics and tantalums. All resistors are in Ohm and 1/4W or less unless otherwise specified. Delta: internal component. B+: B+ Line B-: B- Line Voltage and waveforms are dc with respect to ground under no-signal (detuned) conditions. no mark: FM

Voltages are taken with a VOM (Input impedance 10M Ohm). Voltage variations may be noted due to normal production tolerances. Waveforms are taken with an oscilloscope. Voltage variations may be noted due to normal production tolerances. Circled numbers refer to waveforms. Signal path. FM

3-4. SCHEMATIC DIAGRAM (DISPLAY SECTION)

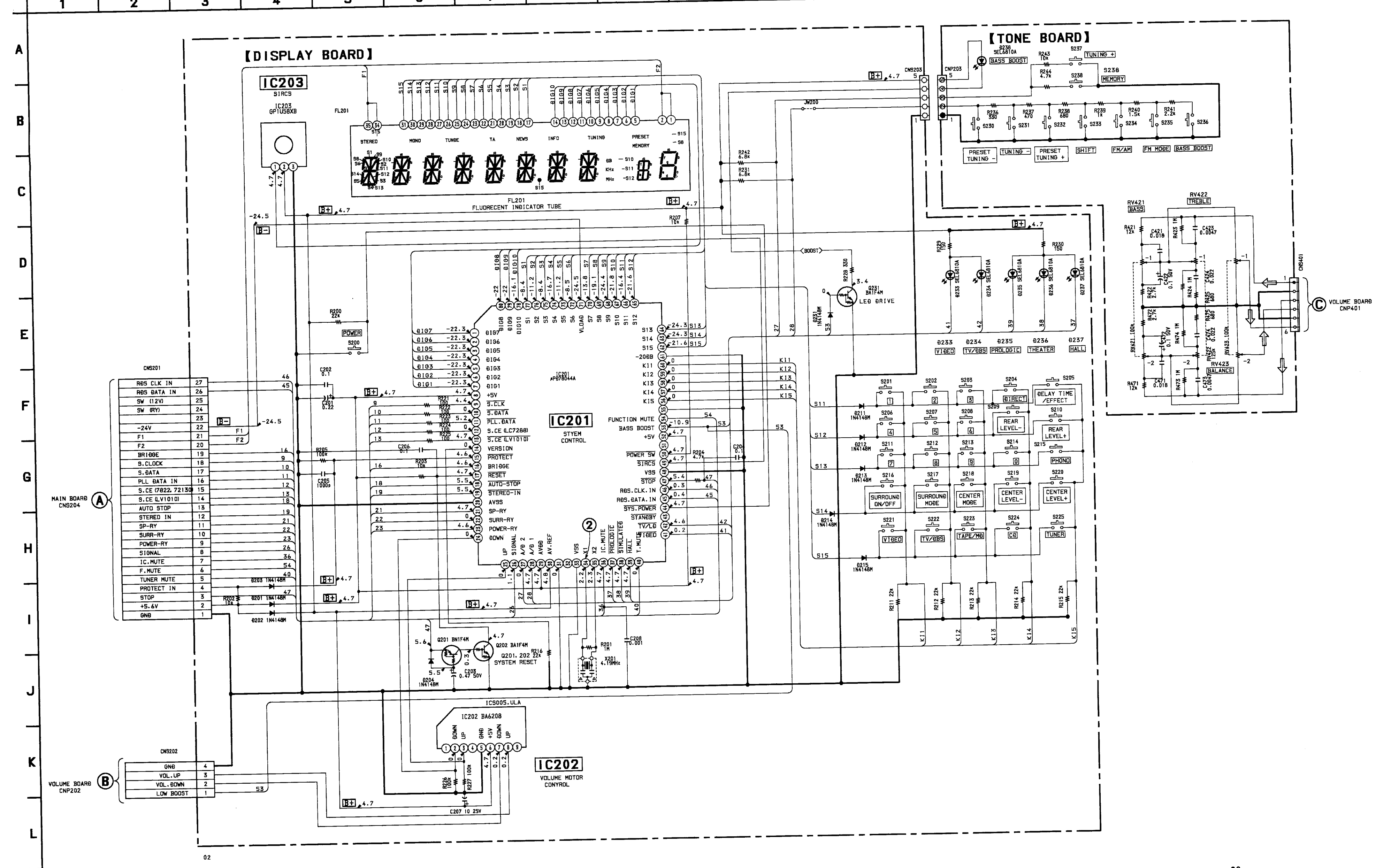

Pinout table for IC201 (SYSTEM CONTROL) with pins 1-27 and their functions.

MAIN BOARD CN204

VOLUME BOARD CNP202

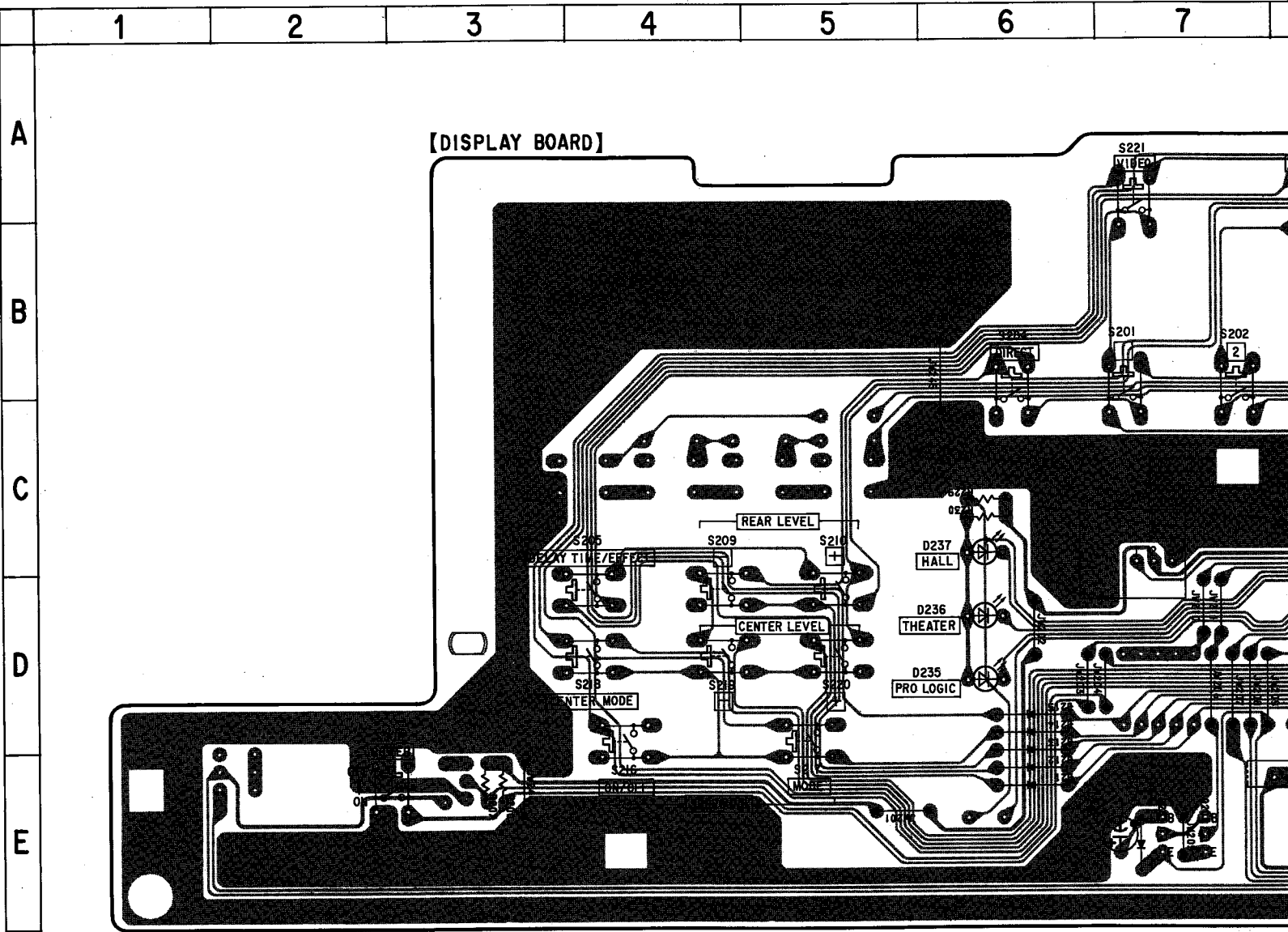

● SEMICONDUCTOR LOCATION

Ref. No.	Location	Ref. No.	Location
D201	D-12	D236	D-6
D202	D-12	D237	C-6
D203	E-12	D238	B-18
D204	E-7		
D211	E-6		
		IC201	D-10
D212	E-6	IC202	E-13
D213	D-6	IC203	C-7
D214	D-6		
D215	D-6	Q201	E-7
D231	C-12	Q202	E-7
		Q231	C-13
D233	D-12		
D234	C-12		
D235	D-6		

Note:

- ○ — : parts extracted from the component side.
- [Pattern] : Pattern on the side which is seen.

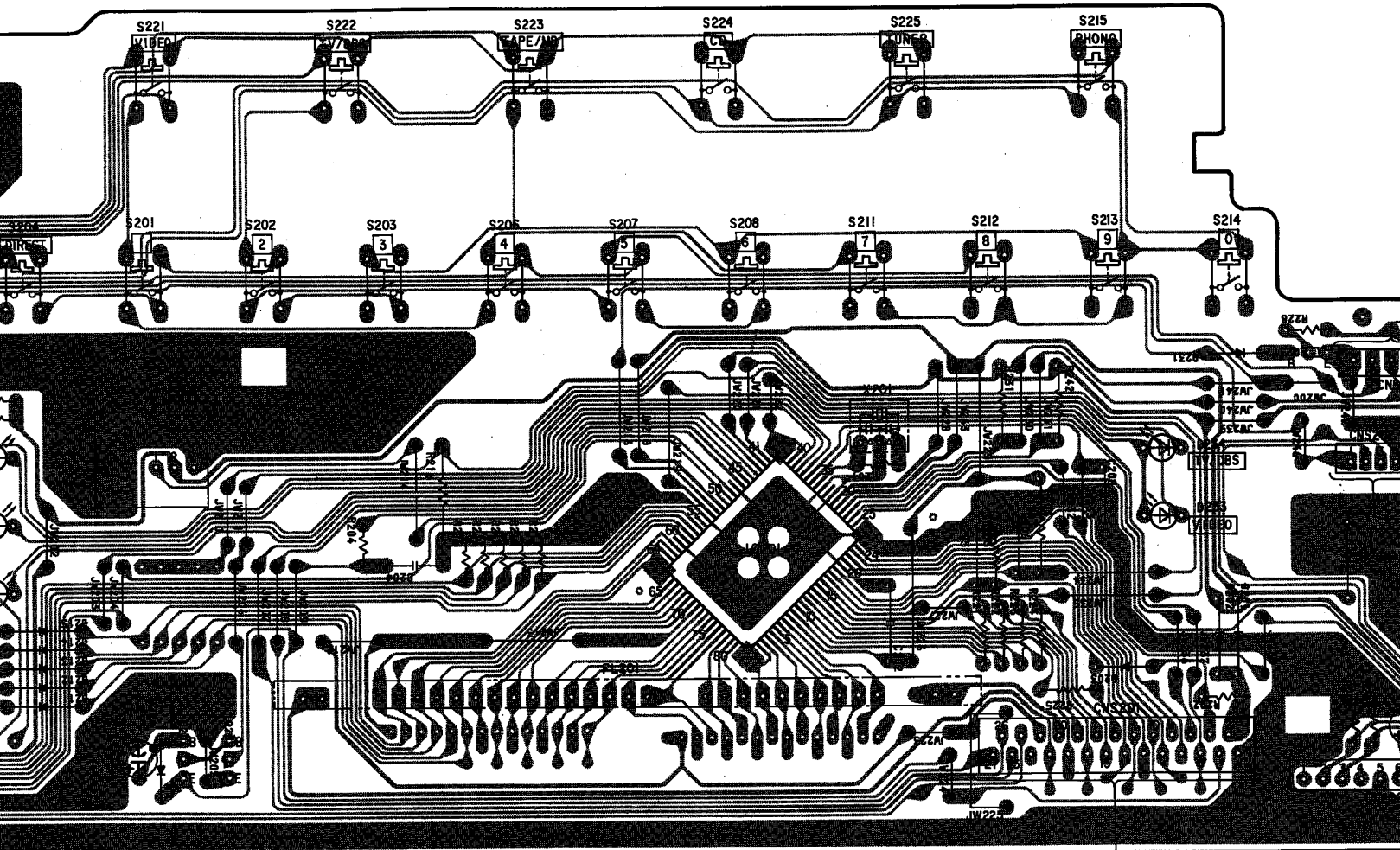

A
MAIN BOARD
CNS204

[TONE BOARD]

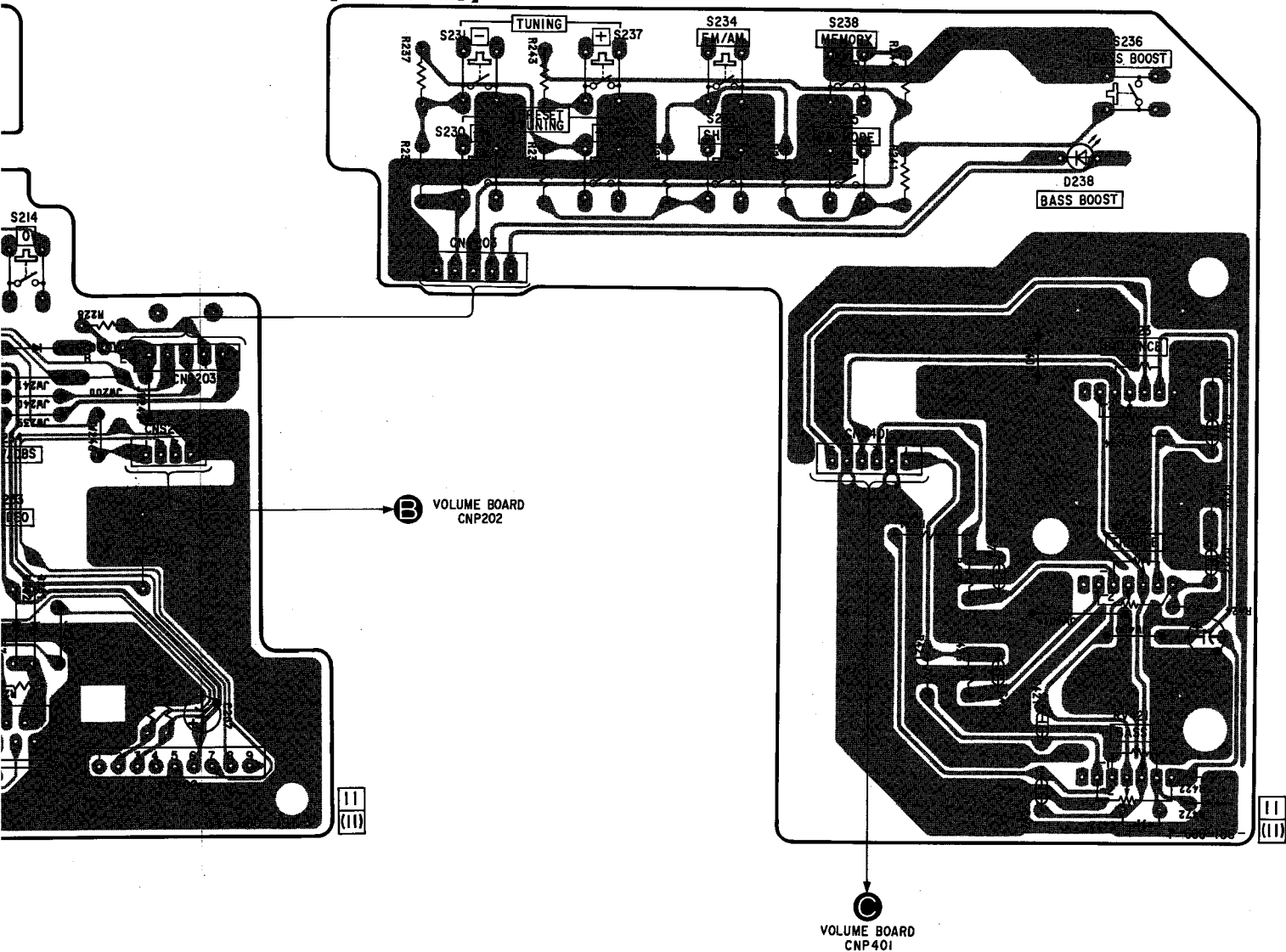

SECTION 4 EXPLODED VIEWS

NOTE :

- -XX, -X mean standardized parts, so they may have some difference from the original one.
- Items marked “ * ” are not stocked since they are seldom required for routine service. Some delay should be anticipated when ordering these items.

- The mechanical parts with no reference number in the exploded views are not supplied.
- Hardware (# mark) list and accessories and packing materials are given in the last of this parts list.
- Abbreviation
CND : Canadian

The components identified by mark Δ or dotted line with mark Δ are critical for safety.
Replace only with part number specified.

Les composants identifiés par une marque Δ sont critiques pour la sécurité.
Ne les remplacer que par une pièce portant le numéro spécifié.

4-1. FRONT PANEL SECTION

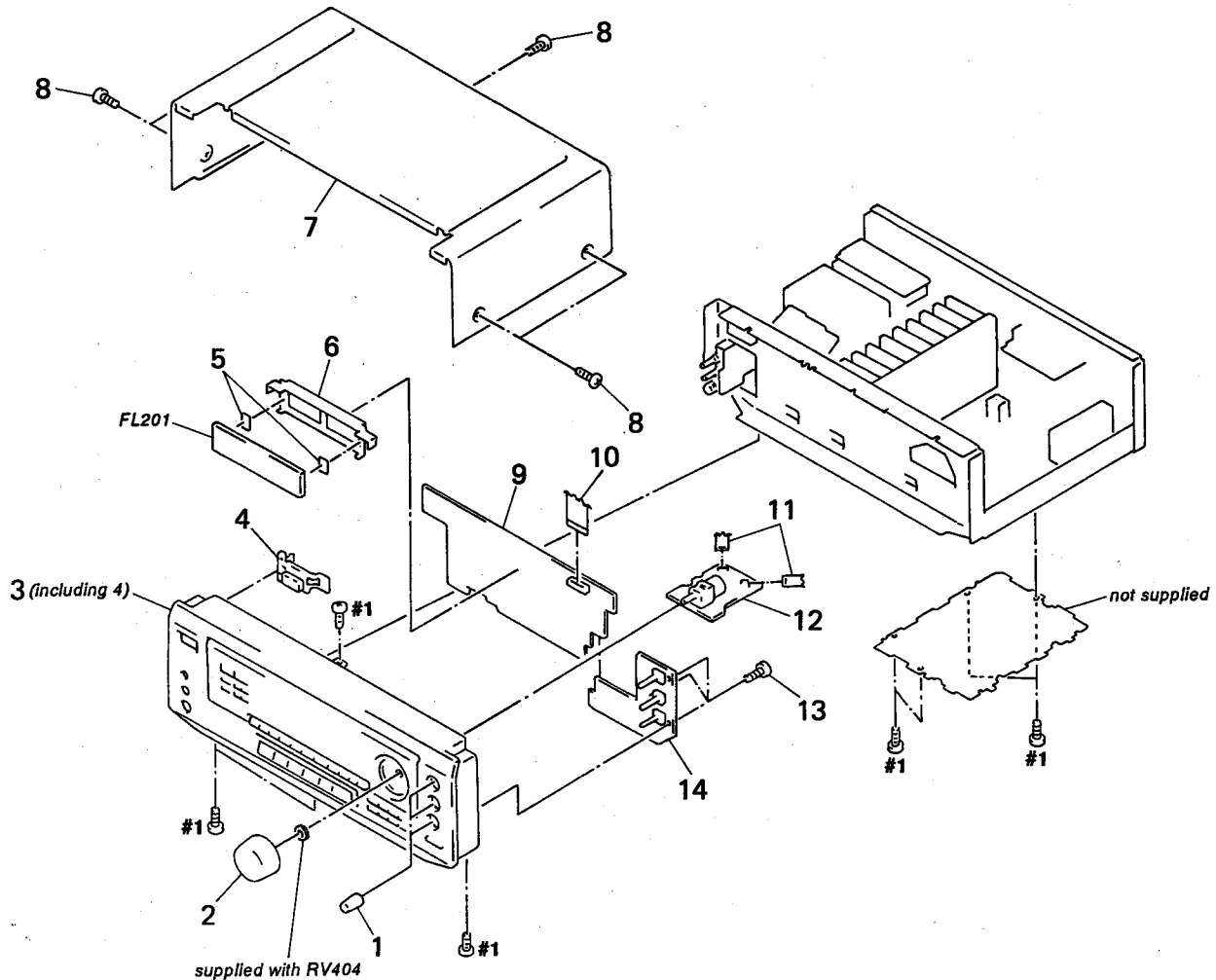

Ref. No.	Part No.	Description	Remark	Ref. No.	Part No.	Description	Remark
1	4-980-639-01	KNOB (R14)		8	3-704-366-01	SCREW (CASE) (M3X8)	
2	X-4946-873-1	KNOB (R48) ASSY		* 9	A-4389-631-A	DISPLAY BOARD, COMPLETE	
3	X-4946-866-1	PANEL ASSY, FRONT (DE405)		10	1-765-343-11	WIRE (FLAT TYPE) (23 CORE)	
3	X-4946-869-1	PANEL ASSY, FRONT (DE505)		11	1-765-314-11	WIRE (FLAT TYPE) (7 CORE)	
3	X-4947-050-1	PANEL ASSY, FRONT (D450Z)		* 12	A-4389-633-A	VOLUME BOARD, COMPLETE	
3	X-4947-051-1	PANEL ASSY, FRONT (D350Z)		13	4-951-620-01	SCREW (2.6X8), +BVTP	
4	4-980-109-01	BUTTON (P-M)		* 14	A-4389-634-A	tone BOARD, COMPLETE	
* 5	4-921-941-01	CUSHION (FL)		FL201	1-517-141-11	INDICATOR TUBE, FLUORESCENT	
* 6	4-943-107-11	HOLDER (FL TUBE)					
* 7	4-980-658-01	CASE (413226)					

4-2. CHASSIS SECTION

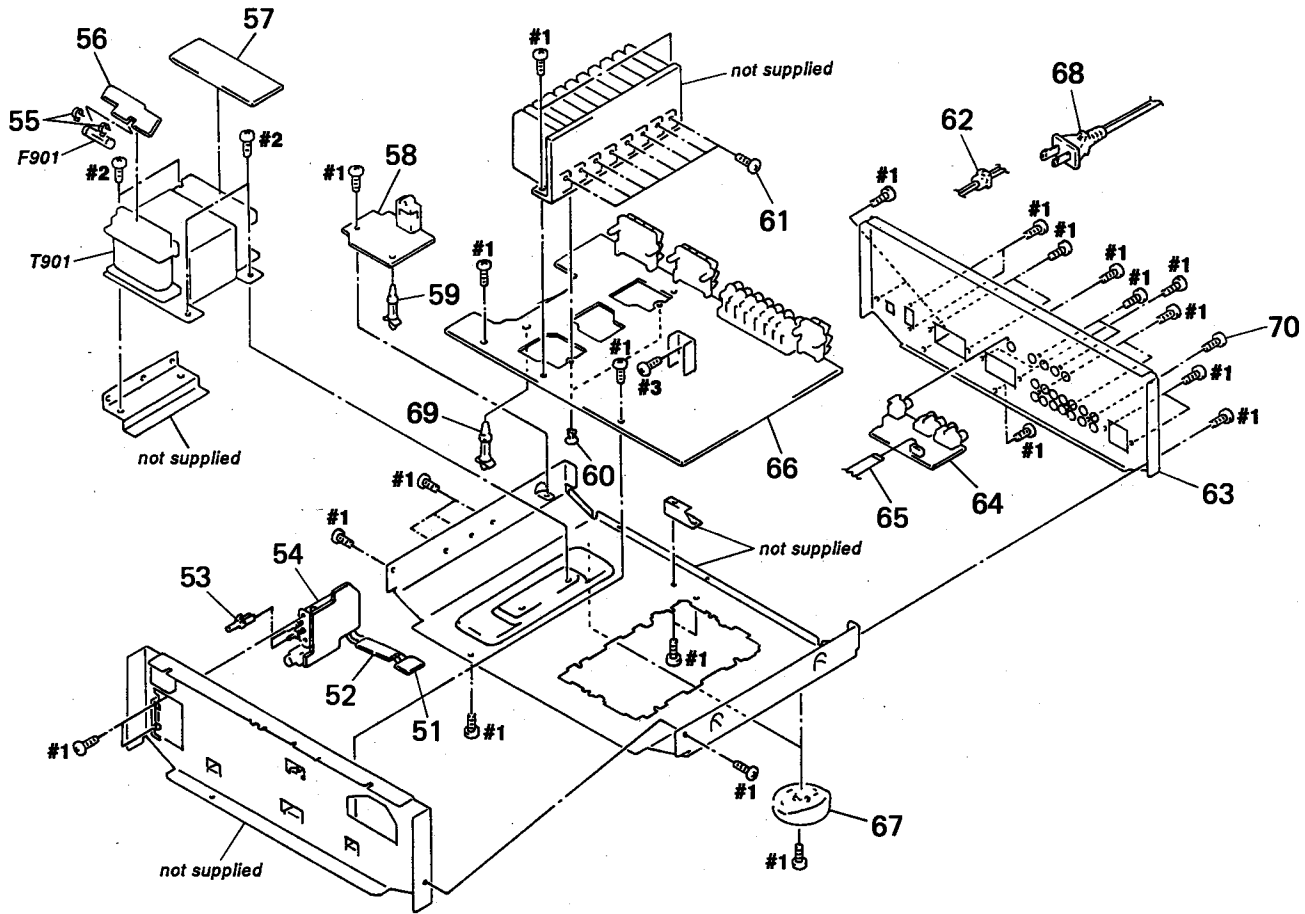

The components identified by mark Δ or dotted line with mark Δ are critical for safety. Replace only with part number specified.

Les composants identifiés par une marque Δ sont critiques pour la sécurité. Ne les remplacer que par une pièce portant le numéro spécifié.

Ref. No.	Part No.	Description	Remark	Ref. No.	Part No.	Description	Remark
* 51	1-660-193-11	SP SW (B) BOARD		65	1-769-908-11	WIRE (FLAT TYPE) (9 CORE)	
* 52	1-660-192-11	SP SW (A) BOARD		* 66	A-4364-908-A	MAIN BOARD, COMPLETE (DE405:US)	
53	4-951-801-01	BUTTON (S)		* 66	A-4389-532-A	MAIN BOARD, COMPLETE (D350Z:CND/DE405:CND)	
* 54	1-660-191-11	SP SW BOARD		* 66	A-4389-640-A	MAIN BOARD, COMPLETE (D450Z:US/DE505:US)	
55	1-533-233-11	HOLDER, FUSE		* 66	A-4389-641-A	MAIN BOARD, COMPLETE (D450Z:CND/DE505:CND)	
* 56	1-660-189-11	PRIMARY BOARD		* 66	A-4390-701-A	MAIN BOARD, COMPLETE (D350Z:US)	
* 57	1-660-190-11	SECONDARY BOARD		67	X-4947-208-1	FOOT ASSY (F50150S)	
* 58	A-4389-632-A	STANDBY BOARD, COMPLETE		Δ 68	1-769-743-11	CORD, POWER	
* 59	4-924-098-31	HOLDER, PC BOARD		69	4-924-098-01	HOLDER, PC BOARD	
60	4-812-134-00	RIVET (DIA. 3.5), NYLON		70	4-909-982-11	SCREW, TAPPING	
61	3-905-609-01	SCREW (TRANSISTOR)		Δ F901	1-576-109-11	FUSE (5A/125V)	
* 62	3-703-244-00	BUSHING (2104), CORD		Δ T901	1-429-699-11	TRANSFORMER, POWER(D350Z:US/DE405:US)	
* 63	4-980-646-01	PANEL, BACK (DE505:US)		Δ T901	1-429-522-11	TRANSFORMER, POWER (D350Z:CND/DE405: CND)	
* 63	4-980-646-11	PANEL, BACK (DE505:CND)		Δ T901	1-429-525-11	TRANSFORMER, POWER(D450Z:US/DE505:US)	
* 63	4-980-646-61	PANEL, BACK (D450Z:US)		Δ T901	1-429-526-11	TRANSFORMER, POWER (D450Z:CND/DE505: CND)	
* 63	4-980-646-71	PANEL, BACK (D450Z:CND)					
* 63	4-980-647-01	PANEL, BACK (DE405:US)					
* 63	4-980-647-11	PANEL, BACK (DE405:CND)					
* 63	4-980-647-51	PANEL, BACK (D350Z:US)					
* 63	4-980-647-61	PANEL, BACK (D350Z:CND)					
* 64	1-660-195-11	VIDEO BOARD					

DISPLAY

SECTION 5 ELECTRICAL PARTS LIST

NOTE :

- Due to standardization, replacements in the parts list may be different from the parts specified in the diagrams or the components used on the set.
- -XX, -X mean standardized parts, so they may have some difference from the original one.
- RESISTORS
All resistors are in ohms
METAL : Metal-film resistor
METAL OXIDE :Metal oxide-film resistor
F : nonflammable
- Items marked " * " are not stocked since they are seldom required for routine service. Some delay should be anticipated when ordering these items.

● SEMICONDUCTORS

In each case, u : μ , for example :
uA..... : μ A....., uPA..... : μ PA.....
uPB..... : μ PB....., uPC..... : μ PC.....
uPD..... : μ PD.....

● CAPACITORS

uF : μ F

● COILS

uH : μ H

● Abbreviation

CND : Canadian

The components identified by mark Δ or dotted line with mark Δ are critical for safety.
Replace only with part number specified.

Les composants identifiés par une marque Δ sont critiques pour la sécurité.
Ne les remplacer que par une pièce portant le numéro spécifié.

When indicating parts by reference number, please include the board.

Ref. No.	Part No.	Description	Remark	Ref. No.	Part No.	Description	Remark
*	A-4389-631-A	DISPLAY BOARD, COMPLETE *****				< INDICATOR TUBE >	
*	4-921-941-01	CUSHION (FL)		FL201	1-517-141-11	INDICATOR TUBE, FLUORESCENT	
*	4-943-107-11	HOLDER (FL TUBE)				< TERMINAL, EARTH >	
		< CAPACITOR >		*	G900	1-537-738-21	TERMINAL, EARTH
C201	1-104-905-11	CAPACITOR	0.22F			< IC >	
C202	1-164-159-11	CERAMIC	0.1uF				
C203	1-124-465-00	ELECT	0.47uF	20%	50V	IC201	8-759-385-78 IC uPD78044AGF-165-3B9
C204	1-164-159-11	CERAMIC	0.1uF		50V	IC202	8-759-962-08 IC BA6208
C205	1-162-294-31	CERAMIC	0.001uF	10%	50V	IC203	8-749-923-11 IC GP1U58XB
C206	1-164-159-11	CERAMIC	0.1uF		50V		< TRANSISTOR >
C207	1-126-096-11	ELECT	10uF	20%	35V	Q201	8-729-900-63 TRANSISTOR DTA124ES
C208	1-162-294-31	CERAMIC	0.001uF	10%	50V	Q202	8-729-900-36 TRANSISTOR DTC124ES
		< CONNECTOR >		Q231	8-729-900-36	TRANSISTOR DTC124ES	
* CNS201	1-568-741-11	SOCKET, CONNECTOR 23P				< RESISTOR >	
* CNS202	1-770-397-11	HOUSING, CONNECTOR(PC BOARD)4P		R200	1-249-433-11	CARBON	22K 5% 1/4W
* CNS203	1-565-481-11	CONNECTOR, BOARD TO BOARD 5P		R201	1-247-903-00	CARBON	1M 5% 1/4W
		< DIODE >		R202	1-249-429-11	CARBON	10K 5% 1/4W
D201	8-719-987-63	DIODE 1N4148M		R203	1-249-429-11	CARBON	10K 5% 1/4W
D202	8-719-987-63	DIODE 1N4148M		R204	1-249-425-11	CARBON	4.7K 5% 1/4W
D203	8-719-987-63	DIODE 1N4148M		R205	1-249-441-11	CARBON	100K 5% 1/4W
D204	8-719-987-63	DIODE 1N4148M		R207	1-249-429-11	CARBON	10K 5% 1/4W
D211	8-719-987-63	DIODE 1N4148M		R211	1-249-433-11	CARBON	22K 5% 1/4W
D212	8-719-987-63	DIODE 1N4148M		R212	1-249-433-11	CARBON	22K 5% 1/4W
D213	8-719-987-63	DIODE 1N4148M		R213	1-249-433-11	CARBON	22K 5% 1/4W
D214	8-719-987-63	DIODE 1N4148M		R214	1-249-433-11	CARBON	22K 5% 1/4W
D215	8-719-987-63	DIODE 1N4148M		R215	1-249-433-11	CARBON	22K 5% 1/4W
D231	8-719-987-63	DIODE 1N4148M		R216	1-249-433-11	CARBON	22K 5% 1/4W
D233	8-719-313-72	LED SEL3810A-CD (VIDEO)		R221	1-247-807-31	CARBON	100 5% 1/4W
D234	8-719-313-72	LED SEL3810A-CD (TV/DBS)		R222	1-247-807-31	CARBON	100 5% 1/4W
D235	8-719-313-72	LED SEL3810A-CD (PRO LOGIC)		R223	1-247-807-31	CARBON	100 5% 1/4W
D236	8-719-313-72	LED SEL3810A-CD (THEATER)		R224	1-247-807-31	CARBON	100 5% 1/4W
D237	8-719-313-72	LED SEL3810A-CD (HALL)		R225	1-247-807-31	CARBON	100 5% 1/4W
				R226	1-249-441-11	CARBON	100K 5% 1/4W

Ref. No.	Part No.	Description	Remark
R227	1-249-441-11	CARBON	100K 5% 1/4W
R228	1-249-411-11	CARBON	330 5% 1/4W
R229	1-249-407-11	CARBON	150 5% 1/4W
R230	1-249-407-11	CARBON	150 5% 1/4W
R231	1-249-427-11	CARBON	6.8K 5% 1/4W
R242	1-249-427-11	CARBON	6.8K 5% 1/4W
R741	1-247-753-11	CARBON	1.2K 5% 1/2W
R742	1-247-753-11	CARBON	1.2K 5% 1/2W
R791	1-247-753-11	CARBON	1.2K 5% 1/2W
R792	1-247-753-11	CARBON	1.2K 5% 1/2W

< SWITCH >

S200	1-554-303-21	SWITCH, TACTILE (POWER)
S201	1-554-303-21	SWITCH, TACTILE (1)
S202	1-554-303-21	SWITCH, TACTILE (2)
S203	1-554-303-21	SWITCH, TACTILE (3)
S204	1-554-303-21	SWITCH, TACTILE (DIRECT)
S205	1-554-303-21	SWITCH, TACTILE (DELAY TIME/EFFECT)
S206	1-554-303-21	SWITCH, TACTILE (4)
S207	1-554-303-21	SWITCH, TACTILE (5)
S208	1-554-303-21	SWITCH, TACTILE (6)
S209	1-554-303-21	SWITCH, TACTILE (REAR LEVEL, -)
S210	1-554-303-21	SWITCH, TACTILE (REAR LEVEL, +)
S211	1-554-303-21	SWITCH, TACTILE (7)
S212	1-554-303-21	SWITCH, TACTILE (8)
S213	1-554-303-21	SWITCH, TACTILE (9)
S214	1-554-303-21	SWITCH, TACTILE (0)
S215	1-554-303-21	SWITCH, TACTILE (PHONO)
S216	1-554-303-21	SWITCH, TACTILE (SURROUND, ON/OFF)
S217	1-554-303-21	SWITCH, TACTILE (SURROUND, MODE)
S218	1-554-303-21	SWITCH, TACTILE (CENTER MODE)
S219	1-554-303-21	SWITCH, TACTILE (CENTER LEVEL, -)
S220	1-554-303-21	SWITCH, TACTILE (CENTER LEVEL, +)
S221	1-554-303-21	SWITCH, TACTILE (VIDEO)
S222	1-554-303-21	SWITCH, TACTILE (TV/DBS)
S223	1-554-303-21	SWITCH, TACTILE (TAPE/MD)
S224	1-554-303-21	SWITCH, TACTILE (CD)
S225	1-554-303-21	SWITCH, TACTILE (TUNER)

< VIBRATOR >

X201	1-577-101-11	VIBRATOR, CERAMIC (4.19MHz)
------	--------------	-----------------------------

Ref. No.	Part No.	Description	Remark
*	A-4364-908-A	MAIN BOARD, COMPLETE (DE405:US)	
*	A-4389-532-A	MAIN BOARD, COMPLETE (D350Z:CND/ DE405:CND)	
*	A-4389-640-A	MAIN BOARD, COMPLETE (D450Z:US/ DE505:US)	
*	A-4389-641-A	MAIN BOARD, COMPLETE (D450Z:CND/ DE505:CND)	
*	A-4390-701-A	MAIN BOARD, COMPLETE (D350Z:US) *****	
	3-905-609-01	SCREW (TRANSISTOR)	
	4-812-134-00	RIVET (DIA. 3.5), NYLON	
	7-682-548-04	SCREW +BVTT 3X8 (S)	

< CAPACITOR >

C302	1-126-934-11	ELECT	220uF	20%	16V
C303	1-130-489-00	MYLAR	0.033uF	5%	50V
C304	1-137-365-11	FILM	0.0015uF	5%	50V
C305	1-130-489-00	MYLAR	0.033uF	5%	50V
C306	1-124-903-11	ELECT	1uF	20%	50V
C307	1-126-964-11	ELECT	10uF	20%	50V
C308	1-126-964-11	ELECT	10uF	20%	50V
C309	1-162-291-31	CERAMIC	560PF	10%	50V
C310	1-126-962-11	ELECT	3.3uF	20%	50V
C311	1-124-925-11	ELECT	2.2uF	20%	100V
C312	1-126-934-11	ELECT	220uF	20%	16V
C313	1-126-934-11	ELECT	220uF	20%	16V
C314	1-136-165-00	FILM	0.1uF	5%	50V
C316	1-126-964-11	ELECT	10uF	20%	50V
C317	1-126-933-11	ELECT	100uF	20%	16V
C318	1-137-363-91	FILM	680PF	5%	50V
C322	1-126-962-11	ELECT	3.3uF	20%	50V
C323	1-136-173-00	FILM	0.47uF	5%	50V
C324	1-126-967-11	ELECT	47uF	20%	16V
C325	1-136-165-00	FILM	0.1uF	5%	50V
C326	1-136-165-00	FILM	0.1uF	5%	50V
C327	1-124-902-00	ELECT	0.47uF	20%	50V
C328	1-126-963-11	ELECT	4.7uF	20%	50V
C329	1-124-902-00	ELECT	0.47uF	20%	50V
C330	1-126-963-11	ELECT	4.7uF	20%	50V
C331	1-124-250-11	ELECT	0.15uF	20%	50V
C332	1-126-962-11	ELECT	3.3uF	20%	50V
C333	1-124-250-11	ELECT	0.15uF	20%	50V
C334	1-137-372-11	FILM	0.022uF	5%	50V
C335	1-136-161-00	FILM	0.047uF	5%	50V
C336	1-126-934-11	ELECT	220uF	20%	16V
C337	1-126-964-11	ELECT	10uF	20%	50V
C338	1-126-964-11	ELECT	10uF	20%	50V
C339	1-126-964-11	ELECT	10uF	20%	50V
C340	1-126-964-11	ELECT	10uF	20%	50V
C341	1-126-934-11	ELECT	220uF	20%	16V
C342	1-126-962-11	ELECT	3.3uF	20%	50V
C343	1-126-962-11	ELECT	3.3uF	20%	50V

MAIN

Ref. No.	Part No.	Description	Remark	Ref. No.	Part No.	Description	Remark
C344	1-136-165-00	FILM	0.1uF 5% 50V	C660	1-126-967-11	ELECT	47uF 20% 16V
C345	1-136-165-00	FILM	0.1uF 5% 50V	C661	1-137-372-11	FILM	0.022uF 5% 50V
C346	1-124-902-00	ELECT	0.47uF 20% 50V	C670	1-162-286-31	CERAMIC	220PF 10% 50V
C347	1-126-963-11	ELECT	4.7uF 20% 50V	C702	1-162-282-31	CERAMIC	100PF 10% 50V
C348	1-124-902-00	ELECT	0.47uF 20% 50V	C703	1-126-933-11	ELECT	100uF 20% 10V
C349	1-126-963-11	ELECT	4.7uF 20% 50V	C705	1-102-233-00	CERAMIC	33PF 10% 500V
C350	1-124-250-11	ELECT	0.15uF 20% 50V	C710	1-126-967-11	ELECT	47uF 20% 16V
C351	1-126-962-11	ELECT	3.3uF 20% 50V	C711	1-137-372-11	FILM	0.022uF 5% 50V
C352	1-124-250-11	ELECT	0.15uF 20% 50V	C720	1-162-286-31	CERAMIC	220PF 10% 50V
C353	1-164-159-11	CERAMIC	0.1uF 50V	C721	1-126-923-11	ELECT	220uF 20% 10V
C354	1-164-159-11	CERAMIC	0.1uF 50V	C722	1-126-965-11	ELECT	22uF 20% 50V
C355	1-164-159-11	CERAMIC	0.1uF 50V	C740	1-128-563-11	ELECT	100uF 20% 100V
C356	1-164-159-11	CERAMIC	0.1uF 50V	C741	1-128-563-11	ELECT	100uF 20% 100V
C357	1-164-159-11	CERAMIC	0.1uF 50V	C742	1-126-923-11	ELECT	220uF 20% 10V
C359	1-126-963-11	ELECT	4.7uF 20% 50V	C752	1-162-282-31	CERAMIC	100PF 10% 50V
C360	1-126-963-11	ELECT	4.7uF 20% 50V	C753	1-126-933-11	ELECT	100uF 20% 10V
C363	1-164-159-11	CERAMIC	0.1uF 50V	C755	1-102-233-00	CERAMIC	33PF 10% 500V
C365	1-126-966-11	ELECT	33uF 20% 16V	C760	1-126-967-11	ELECT	47uF 20% 16V
C366	1-164-159-11	CERAMIC	0.1uF 50V	C761	1-137-372-11	FILM	0.022uF 5% 50V
C401	1-162-282-31	CERAMIC	100PF 10% 50V	C770	1-162-286-31	CERAMIC	220PF 10% 50V
C402	1-126-962-11	ELECT	3.3uF 20% 50V	C801	1-104-664-11	ELECT	47uF 20% 25V
C403	1-126-966-11	ELECT	33uF 20% 16V	C802	1-104-664-11	ELECT	47uF 20% 25V
C404	1-162-282-31	CERAMIC	100PF 10% 50V	C803	1-125-556-11	ELECT(BLOCK)	8200uF 20% 56V (D350Z:US)
C405	1-137-459-11	FILM	0.0056uF 5% 100V	C803	1-128-591-11	ELECT	6800uF 20% 56V (D350Z:CND/DE405:CND)
C406	1-164-159-11	CERAMIC	0.1uF 50V	C803	1-109-932-12	ELECT	10000uF 20% 71V (D450Z:US/DE505:US)
C407	1-137-365-11	FILM	0.0015uF 5% 50V	C803	1-107-766-11	ELECT	8200uF 20% 71V (D450Z:CND/DE405:US/DE505:CND)
C408	1-162-294-31	CERAMIC	0.001uF 10% 50V	C804	1-125-556-11	ELECT(BLOCK)	8200uF 20% 56V (D350Z:US)
C409	1-126-962-11	ELECT	3.3uF 20% 50V	C804	1-128-591-11	ELECT	6800uF 20% 56V (D350Z:CND/DE405:CND)
C410	1-164-159-11	CERAMIC	0.1uF 50V	C804	1-109-932-12	ELECT	10000uF 20% 71V (D450Z:US/DE505:US)
C412	1-162-291-31	CERAMIC	560PF 10% 50V	C804	1-107-766-11	ELECT	8200uF 20% 71V (D450Z:CND/DE405:US/DE505:CND)
C413	1-164-159-11	CERAMIC	0.1uF 50V	C805	1-137-420-11	FILM	0.047uF 10% 100V
C415	1-164-159-11	CERAMIC	0.1uF 50V	C806	1-137-420-11	FILM	0.047uF 10% 100V
C416	1-164-159-11	CERAMIC	0.1uF 50V	C807	1-124-903-11	ELECT	1uF 20% 50V
C434	1-162-286-31	CERAMIC	220PF 10% 50V	C808	1-104-664-11	ELECT	47uF 20% 25V
C435	1-162-286-31	CERAMIC	220PF 10% 50V	C809	1-104-664-11	ELECT	47uF 20% 25V
C451	1-162-282-31	CERAMIC	100PF 10% 50V	C810	1-124-903-11	ELECT	1uF 20% 50V
C452	1-126-962-11	ELECT	3.3uF 20% 50V	C811	1-126-951-11	ELECT	470uF 20% 35V
C453	1-126-966-11	ELECT	33uF 20% 16V	C812	1-126-951-11	ELECT	470uF 20% 35V
C454	1-162-282-31	CERAMIC	100PF 10% 50V	C813	1-164-088-11	CERAMIC	0.001uF 50V
C455	1-137-459-11	FILM	0.0056uF 5% 100V	C814	1-164-088-11	CERAMIC	0.001uF 50V
C457	1-137-365-11	FILM	0.0015uF 5% 50V	C815	1-104-664-11	ELECT	47uF 20% 25V
C459	1-126-962-11	ELECT	3.3uF 20% 50V	C816	1-104-664-11	ELECT	47uF 20% 25V
C460	1-164-159-11	CERAMIC	0.1uF 50V	C820	1-161-494-00	CERAMIC	0.022uF 25V
C602	1-162-282-31	CERAMIC	100PF 10% 50V	C821	1-161-494-00	CERAMIC	0.022uF 25V
C603	1-126-933-11	ELECT	100uF 20% 10V	C822	1-104-664-11	ELECT	47uF 20% 25V
C605	1-102-233-00	CERAMIC	33PF 10% 500V				
C610	1-126-967-11	ELECT	47uF 20% 16V				
C611	1-137-372-11	FILM	0.022uF 5% 50V				
C620	1-162-286-31	CERAMIC	220PF 10% 50V				
C652	1-162-282-31	CERAMIC	100PF 10% 50V				
C653	1-126-933-11	ELECT	100uF 20% 10V				
C655	1-102-233-00	CERAMIC	33PF 10% 500V				

Ref. No.	Part No.	Description	Remark
C823	1-104-664-11	ELECT	47uF 20% 25V
C950	1-126-952-11	ELECT	1000uF 20% 16V
C951	1-164-097-11	CERAMIC	0.022uF 50V
C952	1-124-903-11	ELECT	1uF 20% 50V
C953	1-124-464-11	ELECT	0.22uF 20% 50V
C954	1-126-964-11	ELECT	10uF 20% 50V
C955	1-164-159-11	CERAMIC	0.1uF 50V

< CONNECTOR >

CNP702	1-750-388-11	PIN, CONNECTOR 5P	
CNP706	1-764-477-11	PIN, CONNECTOR (PC BOARD) 8P	
* CNS204	1-568-742-11	SOCKET, CONNECTOR 23P	
* CNS251	1-568-439-11	SOCKET, CONNECTOR 7P	
* CNS301	1-568-442-11	SOCKET, CONNECTOR 9P	
* CNS701	1-568-439-11	SOCKET, CONNECTOR 7P	
CNS802	1-766-200-11	SOCKET, CONNECTOR PIN 5P	

< DIODE >

D610	8-719-987-63	DIODE 1N4148M	
D710	8-719-987-63	DIODE 1N4148M	
D721	8-719-815-85	DIODE 1S1585	
D722	8-719-815-85	DIODE 1S1585	
D723	8-719-987-63	DIODE 1N4148M	
D724	8-719-987-63	DIODE 1N4148M	
D725	8-719-987-63	DIODE 1N4148M	
D801	8-719-002-33	DIODE UZL-24L	
D802	8-719-302-38	DIODE RBV-602-01	
D804	8-719-010-38	DIODE UZ-5.1BSB	
D805	8-719-002-33	DIODE UZL-24L	
D810	8-719-024-99	DIODE 11ES2-NTA2B	
D811	8-719-024-99	DIODE 11ES2-NTA2B	
D812	8-719-024-99	DIODE 11ES2-NTA2B	
D813	8-719-024-99	DIODE 11ES2-NTA2B	
D814	8-719-987-63	DIODE 1N4148M	
D815	8-719-987-63	DIODE 1N4148M	
D817	8-719-001-30	DIODE UZL-9H3	
D818	8-719-987-63	DIODE 1N4148M	
D820	8-719-024-99	DIODE 11ES2-NTA2B	
D821	8-719-024-99	DIODE 11ES2-NTA2B	
D822	8-719-024-99	DIODE 11ES2-NTA2B	
D823	8-719-024-99	DIODE 11ES2-NTA2B	

< TERMINAL, EARTH >

* G200	1-537-738-21	TERMINAL, EARTH	
* G201	1-537-738-21	TERMINAL, EARTH	
* G202	1-537-738-21	TERMINAL, EARTH	

< IC >

IC300	8-759-341-23	IC LV1011	
IC301	8-759-248-74	IC LA2785	
IC302	8-759-636-74	IC M5218AP-22	
IC401	8-759-805-14	IC LC7822	

Ref. No.	Part No.	Description	Remark
IC402	8-759-636-74	IC M5218AP-22	
IC701	8-759-326-52	IC uPC2581V	
IC702	8-759-326-52	IC uPC2581V	
IC801	8-759-287-58	IC TA78M12P	
IC802	8-759-604-45	IC M5F79M12	
IC950	8-759-333-83	IC NJM2103D	

< JACK >

J401	1-695-188-31	JACK, PIN 4P (PHONO,CD)	
J402	1-770-015-11	JACK, PIN 6P (TAPE/MD,TV/DBS)	
J403	1-573-028-31	JACK, PIN 4P (VIDEO)	

< COIL >

L301	1-410-509-11	INDUCTOR	10uH
L302	1-410-509-11	INDUCTOR	10uH
L401	1-410-509-11	INDUCTOR	10uH
L601	1-420-872-00	COIL, AIR-CORE	
L651	1-420-872-00	COIL, AIR-CORE	

L701	1-420-872-00	COIL, AIR-CORE	
L751	1-420-872-00	COIL, AIR-CORE	

< TRANSISTOR >

Q303	8-729-922-37	TRANSISTOR	2SD2144S
Q304	8-729-922-37	TRANSISTOR	2SD2144S
Q307	8-729-922-37	TRANSISTOR	2SD2144S
Q308	8-729-922-37	TRANSISTOR	2SD2144S
Q601	8-729-119-76	TRANSISTOR	2SA1175-HFE
Q602	8-729-141-30	TRANSISTOR	2SC3623A-LK
Q603	8-749-010-25	IC MN2488-OPY-M	
Q604	8-749-010-26	IC MP1620-OPY-M	
Q610	8-729-119-78	TRANSISTOR	2SC403SP-51
Q620	8-729-140-82	TRANSISTOR	2SA988-PAFAEA
Q651	8-729-119-76	TRANSISTOR	2SA1175-HFE
Q652	8-729-141-30	TRANSISTOR	2SC3623A-LK
Q653	8-749-010-25	IC MN2488-OPY-M	
Q654	8-749-010-26	IC MP1620-OPY-M	
Q670	8-729-140-82	TRANSISTOR	2SA988-PAFAEA
Q701	8-729-119-76	TRANSISTOR	2SA1175-HFE
Q702	8-729-141-30	TRANSISTOR	2SC3623A-LK
Q703	8-749-010-25	IC MN2488-OPY-M	
Q704	8-749-010-26	IC MP1620-OPY-M	
Q710	8-729-119-78	TRANSISTOR	2SC403SP-51
Q720	8-729-140-82	TRANSISTOR	2SA988-PAFAEA
Q721	8-729-140-82	TRANSISTOR	2SA988-PAFAEA
Q722	8-729-140-84	TRANSISTOR	2SC1841-PAFAEA
Q723	8-729-119-78	TRANSISTOR	2SC403SP-51
Q740	8-729-140-84	TRANSISTOR	2SC1841-PAFAEA
Q741	8-729-140-84	TRANSISTOR	2SC1841-PAFAEA
Q751	8-729-119-76	TRANSISTOR	2SA1175-HFE
Q752	8-729-141-30	TRANSISTOR	2SC3623A-LK
Q753	8-749-010-25	IC MN2488-OPY-M	
Q754	8-749-010-26	IC MP1620-OPY-M	

MAIN

Ref. No.	Part No.	Description	Remark	Ref. No.	Part No.	Description	Remark
Q770	8-729-140-82	TRANSISTOR	2SA988-PAFAEA	R412	1-247-897-11	CARBON	560K 5% 1/4W
Q801	8-729-140-97	TRANSISTOR	2SB734-34	R413	1-249-437-11	CARBON	47K 5% 1/4W
Q802	8-729-119-78	TRANSISTOR	2SC403SP-51	R414	1-249-425-11	CARBON	4.7K 5% 1/4W
Q803	8-729-030-18	TRANSISTOR	2SD2525	R415	1-249-417-11	CARBON	1K 5% 1/4W
Q808	8-729-180-92	TRANSISTOR	2SD809-K	R416	1-249-417-11	CARBON	1K 5% 1/4W
Q809	8-729-119-78	TRANSISTOR	2SC403SP-51	R417	1-247-897-11	CARBON	560K 5% 1/4W
Q951	8-729-030-18	TRANSISTOR	2SD2525	R420	1-249-441-11	CARBON	100K 5% 1/4W
< RESISTOR >				R435	1-249-418-11	CARBON	1.2K 5% 1/4W
△ R298	1-249-381-11	CARBON	1	R442	1-249-418-11	CARBON	1.2K 5% 1/4W
				R443	1-249-418-11	CARBON	1.2K 5% 1/4W
			(D350Z:US/DE405:US)	R447	1-249-416-11	CARBON	820 5% 1/4W
△ R298	1-249-385-11	CARBON	2.2	R448	1-249-429-11	CARBON	10K 5% 1/4W
				R449	1-249-433-11	CARBON	22K 5% 1/4W
			(CND)	R451	1-249-411-11	CARBON	330 5% 1/4W
△ R298	1-249-389-11	CARBON	4.7	R452	1-249-421-11	CARBON	2.2K 5% 1/4W
				R453	1-249-417-11	CARBON	1K 5% 1/4W
			(D450Z:US/DE505:US)	R454	1-249-417-11	CARBON	1K 5% 1/4W
△ R299	1-249-381-11	CARBON	1	R455	1-249-417-11	CARBON	1K 5% 1/4W
				R456	1-249-417-11	CARBON	1K 5% 1/4W
			(D350Z:US/DE405:US)	R457	1-249-417-11	CARBON	1K 5% 1/4W
△ R299	1-249-385-11	CARBON	2.2	R458	1-249-429-11	CARBON	10K 5% 1/4W
				R459	1-249-437-11	CARBON	47K 5% 1/4W
			(CND)	R460	1-247-897-11	CARBON	560K 5% 1/4W
△ R299	1-249-389-11	CARBON	4.7	R461	1-249-416-11	CARBON	820 5% 1/4W
				R462	1-247-897-11	CARBON	560K 5% 1/4W
			(D450Z:US/DE505:US)	R463	1-249-437-11	CARBON	47K 5% 1/4W
R300	1-247-903-00	CARBON	1M	R465	1-249-417-11	CARBON	1K 5% 1/4W
R301	1-249-421-11	CARBON	2.2K	R466	1-249-417-11	CARBON	1K 5% 1/4W
R302	1-249-421-11	CARBON	2.2K	R467	1-247-897-11	CARBON	560K 5% 1/4W
R303	1-249-439-11	CARBON	68K	R470	1-249-441-11	CARBON	100K 5% 1/4W
R304	1-249-441-11	CARBON	100K	R601	1-249-417-11	CARBON	1K 5% 1/4W
R306	1-249-436-11	CARBON	39K	R602	1-249-439-11	CARBON	68K 5% 1/4W
R307	1-247-862-11	CARBON	20K	R603	1-249-413-11	CARBON	470 5% 1/4W
R308	1-249-421-11	CARBON	2.2K				(D350Z/DE405:CND)
R309	1-249-421-11	CARBON	2.2K	R603	1-249-412-11	CARBON	390 5% 1/4W
R352	1-249-441-11	CARBON	100K				(D450Z/DE405:US/DE505)
R353	1-249-425-11	CARBON	4.7K	R604	1-249-439-11	CARBON	68K 5% 1/4W
R354	1-249-425-11	CARBON	4.7K	R610	1-249-421-11	CARBON	2.2K 5% 1/4W
R355	1-249-425-11	CARBON	4.7K	R611	1-249-437-11	CARBON	47K 5% 1/4W
R356	1-249-425-11	CARBON	4.7K	R613	1-249-414-11	CARBON	560 5% 1/4W
R357	1-249-441-11	CARBON	100K	△ R614	1-249-408-11	CARBON	180 5% 1/4W F
R358	1-249-441-11	CARBON	100K	△ R615	1-249-408-11	CARBON	180 5% 1/4W F
R359	1-249-425-11	CARBON	4.7K	△ R616	1-233-352-21	ENCAPSULATED COMPONENT	F
R360	1-249-425-11	CARBON	4.7K	△ R617	1-249-393-11	CARBON	10 5% 1/4W F
R361	1-249-429-11	CARBON	10K	R618	1-249-389-11	CARBON	4.7 5% 1/4W
R362	1-249-429-11	CARBON	10K	R620	1-249-419-11	CARBON	1.5K 5% 1/4W
R363	1-249-411-11	CARBON	330	R621	1-249-427-11	CARBON	6.8K 5% 1/4W
R401	1-249-411-11	CARBON	330	R623	1-249-437-11	CARBON	47K 5% 1/4W
R402	1-249-421-11	CARBON	2.2K	R630	1-249-426-11	CARBON	5.6K 5% 1/4W
R403	1-249-417-11	CARBON	1K	R631	1-247-887-00	CARBON	220K 5% 1/4W
R404	1-249-417-11	CARBON	1K				(D450Z/DE505)
R405	1-249-417-11	CARBON	1K				
R406	1-249-417-11	CARBON	1K				
R407	1-249-417-11	CARBON	1K				
R408	1-249-429-11	CARBON	10K				
R409	1-249-437-11	CARBON	47K				
R410	1-247-897-11	CARBON	560K				
R411	1-249-416-11	CARBON	820				

The components identified by mark
△ or dotted line with mark △ are
critical for safety.
Replace only with part number
specified.

Les composants identifiés par une
marque △ sont critiques pour la
sécurité.
Ne les remplacer que par une pièce
portant le numéro spécifié.