

STR-D715/D915

SERVICE MANUAL

US Model
Canadian Model
STR-D715/D915
Australian Model
STR-D915

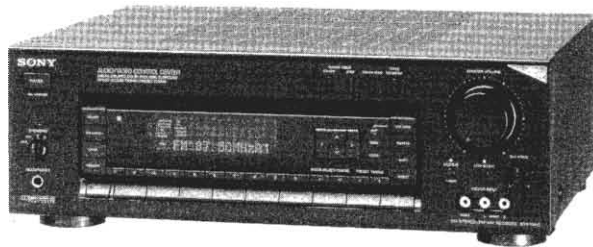

Photo : STR-D915

SPECIFICATIONS

Audio Power Specifications

POWER OUTPUT AND TOTAL HARMONIC DISTORTION

With 8-ohm load, both channels driven, from 20 - 20,000 Hz, rated 110 watts (STR-D915) or 100 watts (STR-D715) per channel minimum RMS power, with no more than 0.3 % total harmonic distortion from 250 milliwatts to rated output. (U.S. A. model only)

Other Specifications

Amplifier section

Continuous RMS power output (8 ohms, at 20 Hz - 20 kHz less than 0.3% (US, Canadian model), 0.7% (Australian model)

STR-D915: 118 W + 118 W

(US, Canadian model)

STR-D915: 110W + 110W (Australian model)

STR-D715: 110 W + 110 W

Surround mode

	Surround mode (8ohms at 1 kHz, THD 0.8 %)	
	STR-D915	STR-D715
FRONT	100 W/ch	80 W/ch
CENTER*	100 W	80 W
REAR	25 W	25 W

* (only in the DOLBY SUR and THEATER modes)

Dynamic power output (US, Canadian model)

STR-D915: 160 W + 160 W (8 ohms)

225 W + 225 W (4 ohms)

STR-D715: 155 W + 155 W (8 ohms)

220 W + 220 W (4 ohms)

Harmonic distortion at rated output (US, Canadian model)

Less than 0.3 %

Frequency response

PHONO: RIAA equalization curve

±0.5 dB

CD, DAT/MD, TAPE MONITOR, TV, LD,

VIDEO 1, 2, 3*, TAPE MONITOR, VIDEO 1, 2, 3*: 10 Hz - 50 kHz, ±1 dB

* STR-D915 only

FM tuner section

Tuning range 87.5 - 108.0 MHz
Antenna terminals 75 ohms, unbalanced
Sensitivity (at 50 dB): 18.3 dBf, 4.5 μV (mono)
38.3 dBf, 45 μV (stereo)

Usable sensitivity 11.2 dBf, 2 μV (IHF)
S/N Mono: 76 dB
Stereo: 70 dB

Harmonic distortion at 1 kHz

Mono: 0.3 %

Stereo: 0.5 %

Separation 45 dB at 1 kHz

Frequency response 30 Hz - 15 kHz, ^{+0.5}-1 dB

Selectivity 60 dB at 400 kHz

AM tuner section

Tuning range 530 - 1710 kHz (with 10 kHz interval*)

(US, Canadian model) 531 - 1710 kHz (with 9 kHz interval)

(Australian model) 531-1602kHz

Antenna Loop antenna

Usable sensitivity 50 dB/m (at 1,000 kHz or 999 kHz)

S/N 54 dB (at 50 mV/m)

Harmonic distortion 0.5% (50 mV/m, 400 Hz)

Selectivity 35 dB (9 kHz), 40 dB (10 kHz)

* You can change the AM tuning interval to 9 kHz. After tuning in any AM tuning in any AM station, turn off the power of receiver once. While holding down the TUNING + button, press the POWER switch. When you change the interval, all the preset stations will be erased. To reset the interval, repeat the same procedure. (US, Canadian model)

Video section

Inputs STR-D915: VIDEO 1,2,3:

1 Vp-p 75 ohms

STR-D715: VIDEO 1,2:

1 Vp-p 75 ohms

Outputs VIDEO 1, 2, MONITOR:

1 Vp-p 75 ohms

General

System Tuner section: PLL quartz-locked

digital synthesizer system

Low-noise NF type equalizer

Power amplifier section: Pure-

complementary SEPP

Power requirements 120 V AC, 60 Hz (US, Canadian model)

240V AC, 50Hz (Australian model)

Power consumption (in standby condition: SW)

STR-D915: USA model: 210 W

Canada model: 305 VA

Australian model: 220W

STR-D715: USA model: 195 W

Canada model: 280 VA

AC outlets Two switched, total 120 W

(US, Canadian model)

One switched, 100W

(Australian model)

Dimensions 430 x 148 x 355 mm

(17 x 5 7/8 x 14 inches)

Mass STR-D915: 10.0 kg (22 lb 1 oz)

STR-D715: 9.7 kg (22 lb 7 oz)

Supplied accessories FM wire antenna (1)

AM loop antenna (1)

Remote commander (1)

Sony Batteries SUM-3(NS) (2)

Design and specifications are subject to change without notice.

Inputs

	Sensitivity	Impedance	S/N Short A Net/78 IHF A Net
PHONO (MM)	2.5 mV	50 kilohms	75 dB/75 dB
CD	300 mV	50 kilohms	82 dB/82 dB
DAT/MD, TV, LD, VIDEO 1, 2, 3*, TAPE MONITOR	250 mV	50 kilohms	82 dB/82 dB

* STR-D915 only

Outputs

REC OUT VIDEO 1, 2 (AUDIO) OUT	Voltage 250 mV Impedance 10 kilohms
HEADPHONES	Accepts low and high impedance headphones

MUTING -20 dB

LOW BOOST +10 dB at 70 Hz

TONE ±8 dB at 100 Hz and 10 kHz

FM STEREO FM-AM RECEIVER
SONY®

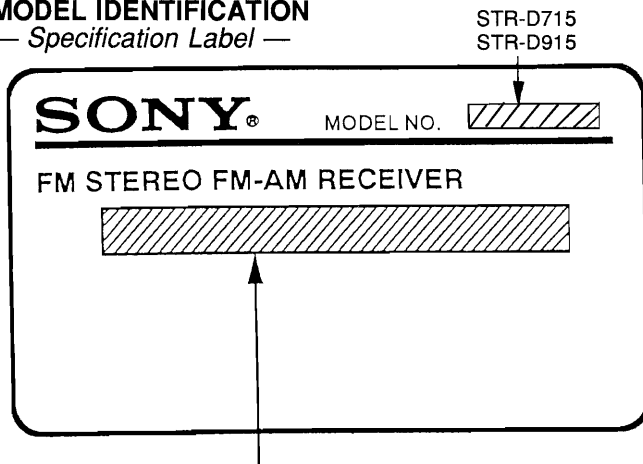

TABLE OF CONTENTS

Section	Title	Page
1.	SERVICING NOTE.....	3
2.	GENERAL.....	4
3.	DIAGRAMS	
3-1.	Circuit Boards Location	7
3-2.	Semiconductor Lead Layouts	8
3-3.	Printed Wiring Boards — SURROUND Section —	10
3-4.	Schematic Diagram — SURROUND Section —	13
3-5.	Schematic Diagram — MAIN Section —	17
3-6.	Printed Wiring Boards — MAIN Section —	21
3-7.	Printed Wiring Boards — DISPLAY Section —	26
3-8.	Schematic Diagram — DISPLAY Section —	31
3-9.	IC Pin Functions	
	• IC106 (TC9174P) LED Driver	34
	• IC202 ((μ PD75518GF-195-3B9) Main Controller.....	35
4.	EXPLODED VIEWS	
4-1.	Cabinet Section	37
4-2.	Chassis Section	38
5.	ELECTRICAL PARTS LIST	39

MODEL IDENTIFICATION

— Specification Label —



US model : 120V AC, 60Hz 195W (D715)
 120V AC, 60Hz 210W (D915)
 Canadian model : 120V AC, 60Hz 280VA (D715)
 120V AC, 60Hz 305VA (D915)
 Australian model : 240V AC, 50Hz 220W

SAFETY CHECK-OUT

After correcting the original service problem, perform the following safety checks before releasing the set to the customer:

Check the antenna terminals, metal trim, “metallized” knobs, screws, and all other exposed metal parts for AC leakage. Check leakage as described below.

LEAKAGE

The AC leakage from any exposed metal part to earth ground and from all exposed metal parts to any exposed metal part having a return to chassis, must not exceed 0.5 mA (500 microampers). Leakage current can be measured by any one of three methods.

1. A commercial leakage tester, such as the Simpson 229 or RCA WT-540A. Follow the manufacturers' instructions to use these instruments.
2. A battery-operated AC milliammeter. The Data Precision 245 digital multimeter is suitable for this job.
3. Measuring the voltage drop across a resistor by means of a VOM or battery-operated AC voltmeter. The “limit” indication is 0.75 V, so analog meters must have an accurate low-voltage scale. The Simpson 250 and Sanwa SH-63Trd are examples of a passive VOM that is suitable. Nearly all battery operated digital multimeters that have a 2V AC range are suitable. (See Fig. A)

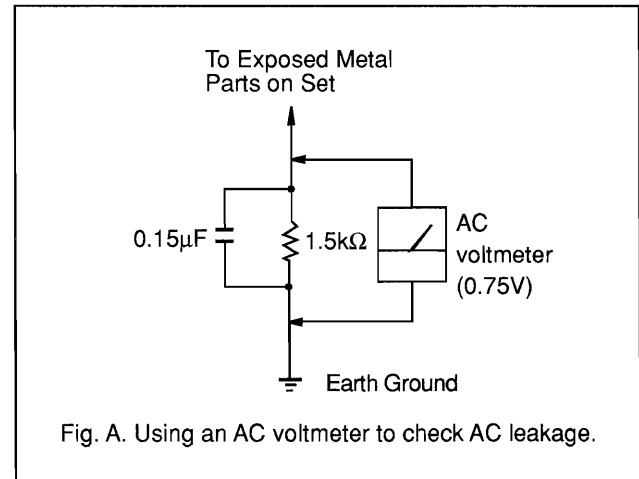

Fig. A. Using an AC voltmeter to check AC leakage.

Notes on chip component replacement

- Never reuse a disconnected chip component.
- Notice that the minus side of a tantalum capacitor may be damaged by heat.

SAFETY-RELATED COMPONENT WARNING !!

COMPONENTS IDENTIFIED BY MARK Δ OR DOTTED LINE WITH MARK Δ ON THE SCHEMATIC DIAGRAMS AND IN THE PARTS LIST ARE CRITICAL TO SAFE OPERATION. REPLACE THESE COMPONENTS WITH SONY PARTS WHOSE PART NUMBERS APPEAR AS SHOWN IN THIS MANUAL OR IN SUPPLEMENTS PUBLISHED BY SONY.

ATTENTION AU COMPOSANT AYANT RAPPORT À LA SÉCURITÉ!!

LES COMPOSANTS IDENTIFIÉS PAR UNE MARQUE Δ SUR LES DIAGRAMMES SCHÉMATIQUES ET LA LISTE DES PIÈCES SONT CRITIQUES POUR LA SÉCURITÉ DE FONCTIONNEMENT. NE REMPLACER CES COMPOSANTS QUE PAR DES PIÈCES SONY DONT LES NUMÉROS SONT DONNÉS DANS CE MANUEL OU DANS LES SUPPLÉMENTS PUBLIÉS PAR SONY.

SECTION 1 SERVICING NOTE

CHECK MODE The movement check of the set as follows :

	SUBJECT	WITH WHAT HELD DOWN	WHAT IS OPERATED	WHAT FUNCTION IS PERFORMED	SUPPLEMENT
1	FACTORY SET	10 KEY [1], [2], [3]	POWER ON	Initialize for Electrical Adjustment	
2	ALL CLEAR	10 KEY [4], [5], [6]	POWER ON	Initialize	
3	AM 9kHz STEP	[INDEX SELECT/ TUNING+]	POWER ON	AM 9k/10k select	Set to AM.
4	SURROUND CLEAR	[TONE ON/DEFEAT]	POWER ON	SOUND FIELD Initialize	
5	FL KEY CHECK	10 KEY [7], [8], [9]	POWER ON	FL Tube Check and KEY Check	
6	DEMO	[DISPLAY]	Continue to hold down.	Demonstration	Set to S.F.OFF.

1. FACTORY SET

When ten-keys [1], [2] and [3] key are pressed simultaneously and the power is turned on, the following data are stored in the respective RAMs

TUNER PRESET		
CH	FM W/AM 9k	FM W/AM 10k
A1	FM 87.50MHz	FM 87.50MHz
A2	FM 88.00MHz	FM 88.00MHz
A3	FM 98.00MHz	FM 98.00MHz
A4	FM 100.00MHz	FM 100.00MHz
A5	FM 108.00MHz	FM 108.00MHz
A6	AM 531kHz	AM 530kHz
A7	AM 621kHz	AM 620kHz
A8	AM 1053kHz	AM 1050kHz
A9	AM 1485kHz	AM 1490kHz
A0	AM 1710kHz	AM 1710kHz

FUNCTION	LD
PHONO	HALL
CD	HALL
TUNER	OFF
VIDEO 1	DOLBY SUR.
VIDEO 2	DOLBY SUR.
VIDEO 3(D915)	DOLBY SUR.
DAT/MD	HALL
LD	DOLBY SUR.
TV	THEATER

2. ALL CLEAR

When ten-keys [4], [5] and [6] key are pressed simultaneously and the power is turned on, all the RAMs are cleared and initialized.

◎Initial Operation Set State(1)

FUNCTION	TUNER	FM 87.50MHz(AM 530kHz)
		FM MODE AUTO
		TUNING LEVEL LOW
		INDEX NO INDEX (.....)
		PRESET NO. None(A_)
MONITOR	VIDEO 1	
TAPE MONITOR	OFF	
LOW BOOST	OFF	
MUTING (-20dB)	OFF	
CURSOR MODE	SUR	
SOUND FIELD	OFF	
STONE	DEFEAT	
FUNC. INDEX NAME	SAME FUNC. NAME	
TEST TONE	OFF	
DISPLAY MODE	NORMAL	
LAST S.F.MODE	ACOUSTIC	

◎Initial Operation Set State (2 : Sound Field)

HALL	BASS(dB)	+2
	TREBLE(dB)	0
	DELAY TIME(ms)	30
	REAR LEVEL(dB)	0
DANCE	BASS(dB)	+8
	TREBLE(dB)	+6
	DELAY TIME(ms)	20
	REAR LEVEL(dB)	0
LIVE	BASS(dB)	+2
	TREBLE(dB)	+4
	DELAY TIME(ms)	30
	REAR LEVEL(dB)	0
DOLBY SURROUND	BASS(dB)	0
	TREBLE(dB)	0
	DELAY TIME(ms)	15
	REAR LEVEL(dB)	0
	CENTER LEVEL(dB)	0
	CENTER MODE	PHANTOM
THEATER	BASS(dB)	+4
	TREBLE(dB)	-4
	DELAY TIME(ms)	15
	REAR LEVEL(dB)	0
	CENTER LEVEL(dB)	0
	CENTER MODE	PHANTOM
ACOUSTIC	BASS(dB)	0
	TREBLE(dB)	0

3. AM 9kHz STEP

During AM 10kHz STEP TUNING, set to AM and turn off the power. Then press and hold down [INDEX SELECT/ TUNING +] key, turn on the power, and change AM TUNING STEP to 9kHz to initialize all the preset channels. (When this procedure is performed during AM 9kHz STEP, AM TUNING STEP is changed to 10kHz.)

4. SURROUND CLEAR

When [TONE ON/DEFEAT] key is held down and the power is turned on, SOUND FIELD memory is initialized.

5. FL TUBE CHECK/KEY CHECK

When ten-keys [7], [8] and [9] key are pressed simultaneously and the power is turned on, FL Tube TEST Display starts.

- All lighting
- One segment lighting for each digit
- Key count indication

The count is decremented for each key input. When it is down to zero, the [POWER] key is used to terminate this check.

SECTION 2 GENERAL

6. DEMO

When SOUND FIELD is turned off and **DISPLAY** key continues to be held down (for 3 seconds), Demonstration starts. If any other key is input, this DEMO stops and processing for that key is done.

* DEMO causes TONE data for ACOUSTIC and DOLBY SURROUND to be changed and set as follows:
 DOLBY SUR's CENTER MODE=PHANTOM
 REAR/CENTER LEVEL=+6dB
 DELAY TIME=20mS

In case of any key input, the state when DEMO is suspended by key input will be maintained.

• ANOTHER FUNCTION

The function that makes FUNCTION INDEX NAME return into FUNCTION NAME. The way of returning is that select any FUNCTIONS you want then press the same FUNCTION KEY during the INDEX input mode.

This section is extracted from instruction manual.

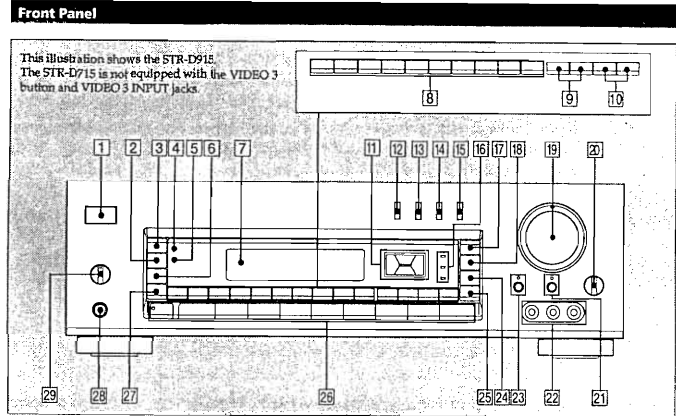

- 1 POWER switch
- 2 FM MODE button (See page 11.)
- 3 FM/AM button (See pages 11, 12.)
- 4 Remote sensor
- 5 STANDBY indicator
(The STANDBY indicator lights up when the power cord is connected.. STR-D915 for Australian model only)
- 6 LEVEL button (See page 12.)
- 7 Display window
- 8 Numeric buttons (See pages 11, 12, 13, 15.)
- 9 INDEX SELECT/TUNING +/- buttons
(See pages 12, 15.)
- 10 PRESET TUNING +/- buttons (See pages 13, 15.)
- 11 DIGITAL PROCESSING CONTROL buttons (See pages 10, 14, 21, 22, 24.)
- 12 SOUND FIELD ON/OFF button (See pages 21, 22, 24, 25.)
- 13 SOUND FIELD MODE button (See pages 21, 22, 24, 25.)
- 14 CENTER MODE button (See pages 20, 21, 24.)
- 15 TONE ON/DEFEAT button (See pages 24, 25.)
- 16 DPC MODE indicators
- 17 DPC MODE button (See pages 10, 14, 21, 22, 24.)
- 18 DISPLAY button (See pages 10, 12, 13, 14, 15.)
- 19 MASTER VOLUME control (See page 9.)
- 20 BALANCE control (See page 9.)
- 21 LOW BOOST button and indicator (See page 9.)
- 22 VIDEO 3 INPUT jacks (STR-D915 only)
- 23 MUTING -20 dB button and indicator (See page 9.)
- 24 SHIFT button (See pages 12, 13.)
- 25 DIRECT button (See page 11.)
- 26 Function selectors and TAPE MONITOR button and indicator (VIDEO 3 button: STR-D915 only)
(See pages 9, 10, 18.)
- 27 MEMORY button (See page 12.)
- 28 HEADPHONES jack
- 29 SPEAKERS selector (See page 9.)

RM-U241 (EXCEPT D915:Canadian)

Remote Commander (Except for The STR-D915 for Canadian Model)

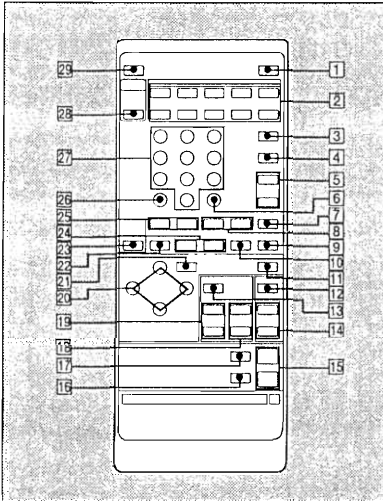

- 1 SYSTEM OFF button (See page 16.)
- 2 SYSTEM CONTROL/FUNCTION TAPE, DAT/MD, CD, TUNER, PHONO, VIDEO 1 VIDEO 2, VIDEO 3, LD, TV buttons (See pages 9, 16, 18.)
- 3 VISUAL POWER button (See page 16.)
- 4 TV/VIDEO, INDEX button (See page 16.)
- 5 CH/PRESET +/- buttons (See page 16.)
- 6 RMS/START, ENTER button (See pages 16, 17.)
- 7 ANT TV/VTR, D (disc) SKIP button (See pages 16, 17.)
- 8 ◀▶ button (See pages 16, 17.)
- 9 ● button (See pages 16, 17.)
- 10 II button (See pages 16, 17.)
- 11 EQ/TONE ON/OFF button (See page 24.)
- 12 SOUND FIELD ON/OFF button (See pages 21, 22, 24, 25.)
- 13 TEST TONE button (See page 21.)
- 14 SOUND FIELD MODE +/- buttons (See pages 21, 22, 24, 25.)
- 15 MASTER VOL +/- buttons (See page 9.)
- 16 MUTING button (See page 9.)
- 17 LOW BOOST button (See page 9.)
- 18 CENTER LEVEL +/- buttons (See page 21.)
- 19 REAR LEVEL +/- buttons (See page 21.)
- 20 DIGITAL PROCESSING CONTROL buttons (See pages 10, 14, 21, 22, 24.)
- 21 DPC MODE button (See pages 14, 21, 22, 24.)
- 22 RMS CLEAR, ■ button (See page 16.)
- 23 BACK GROUND button (See page 17.)
- 24 ◀▶, ▶▶, RMS DIRECTION buttons (See page 16.)
- 25 ◀▶, ▶▶ button (See pages 16, 17.)
- 26 > 10, SHIFT button (See pages 16, 17.)
- 27 Numeric buttons (1 to 0) (See pages 11, 12, 13, 15.)
- 28 TV CONTROL ON button (See page 17.)
- 29 SLEEP button (See page 10.)

RM-P341 (D915:Canadian)

Identifying the Parts and Control

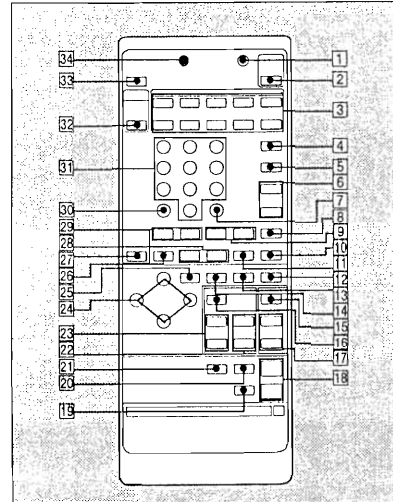

- 1 LEARN button
- 2 SYSTEM OFF button
- 3 SYSTEM CONTROL/FUNCTION TAPE, DAT/MD, CD, TUNER, PHONO, VIDEO 1, VIDEO 2, VIDEO 3, LD, TV buttons
- 4 VISUAL POWER button
- 5 TV/VIDEO, INDEX button
- 6 CH/PRESET +/- buttons
- 7 RMS/START, ENTER button
- 8 ANT TV/VTR, D (disc) SKIP button
- 9 ◀▶ button
- 10 ● button
- 11 II button
- 12 EQ/TONE ON/OFF button
- 13 EQ SLOPE button
- 14 EQ BAND button
- 15 SOUND FIELD ON/OFF button
- 16 TEST TONE button
- 17 SOUND FIELD MODE +/- buttons
- 18 MASTER VOL +/- buttons
- 19 MUTING button
- 20 LOW BOOST button
- 21 DIRECT button
- 22 CENTER LEVEL +/- buttons
- 23 REAR LEVEL +/- buttons
- 24 DIGITAL PROCESSING CONTROL buttons
- 25 DPC MODE button
- 26 RMS CLEAR, ■ button
- 27 BACK GROUND button
- 28 ◀▶, ▶▶, RMS DIRECTION buttons
- 29 ◀▶, ▶▶ button
- 30 > 10, SHIFT button
- 31 Numeric buttons (1 to 0)
- 32 TV CONTROL ON button
- 33 SLEEP button
- 34 LEARN indicator

RM-P341 (D915:Canadian)

Programming Signals of Other Audio/Video Equipment

The remote commander RM-P341 learns various functions of other remote commanders emitting infrared rays and allows you to control most of audio and video equipment from a distance.

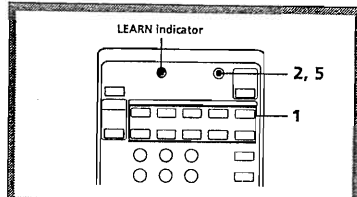

1 Select the function to be programmed with the **FUNCTION** buttons.

2 Press the **LEARN** button so that the **LEARN** indicator lights up.

3 Program a signal.
The buttons you can program differ among the functions. Only the buttons listed in "Operative Buttons" can learn new signals for each function.

① Press the button which shall "learn" the remote-control signal and the LEARN indicator blinks slowly.

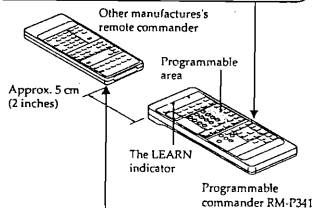

② Press and hold the button of other manufacturer's remote commander whose signal is to be learned.

③ Remove your finger(s) from the button(s) after the LEARN indicator lights up.

Note
If the button which cannot be programmed is pressed in step ①, the LEARN indicator blinks rapidly.

4 Repeat operation for each button to be programmed.

5 Press the **LEARN** button.
The LEARN indicator lights for a few seconds. After the indicator goes off, you can control other equipments with the programmed buttons.

The two remote commanders must:

- face straight each other.
- be placed at a distance of approx. 5 cm (2 inches).
- not be moved during programming operation.

After programming

Be sure to test if the equipment really works with the programmed signals.

Note

If you do not perform the following operation in about one minute after steps 2 and 3-③, the learning mode will be canceled.

Number of signals that the commander can learn

It depends on the format of the signal. If you program signals of Sony equipment, approximately 30 signals can be programmed.

Memory capacity

If the LEARN indicator does not blink or light in step 3-①, ②, the memory capacity has become full. This occurs when other signals stronger than the remote-control signals have been stored because the signals were programmed in a noisy environment or the remote commanders were placed too far apart from each other.

In this case, clear all the signals following the procedure described below and program again from the beginning under the proper conditions.

Notes on programming

- Remote-control signals of equipment of manufactures other than Sony can be programmed only when they are compatible with the infrared wireless remote control system. Since the programmable commander can "learn" only the signals output from another remote commander, it cannot control equipment that does not use a remote commander.
- Don not attempt to use the programmable commander with an air conditioner or other household appliances.
- Note that there are some special remote-control signals that cannot be programmed.
- Even if the POWER of the other manufacture's remote commander is learned, you can not turn on this unit and the other equipment simultaneously with the SYSTEM CONTROL/FUNCTION button.

RM-P341/U241

Programming a New Signal onto a Previously Programmed Button

Follow the programming procedure. The previously programmed signal is cleared and replaced by the new signal.

To clear a programmed signal

- 1 Press the LEARN button so that the LEARN indicator lights up.
- 2 Press the button to be cleared while pressing the BACK GROUND button until the LEARN indicator goes off.

To program a signal onto the ● button for recording

It is not possible to operate any equipment with only the ● button. You can program the rec standby signal and rec start signal under the ● + ► button on RM-P341. With a tape deck, you can also program the signal under the ● + ◀ button (in the reverse direction).

Notes on battery

If the LEARN indicator does not light when a button is pressed, the batteries are almost exhausted. When the batteries are exhausted, the remote commander can no longer operate the unit or programming becomes impossible. If this happens, replace both batteries with new ones. We recommend the use of alkaline batteries for prolonged use.

Changing the Settings of the FUNCTION Buttons

You can replace the functions stored in the FUNCTION buttons.

Hold down one of the FUNCTION buttons you want to change and press one of the numeric (1 to 0) buttons to select the desired function.

After changing the setting of the FUNCTION button, the equipment can be operated with the FUNCTION button you have changed.

To return the function to the initial mode, perform the same operation above.

With the numeric buttons from 1 to 0, each function can be selected as described in the following table:

Numeric buttons	The function to be selected
1	CD player
2	DAT deck
3	MD recorder
4	DECK A
5	DECK B
6	LD player
7	VCR 1 (Remote control mode)
8	VCR 2 (Remote control mode)
9	VCR 3 (Remote control mode)
0	TV

Example: To change the CD FUNCTION button to the DAT function button.

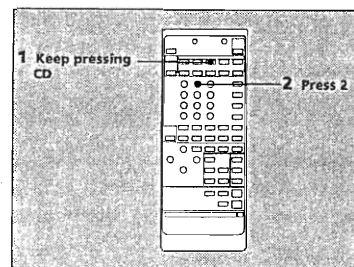

Note

The settings of the TUNER button and the PHONO button cannot be changed.

**SECTION 3
DIAGRAMS**

3-1. CIRCUIT BOARDS LOCATION

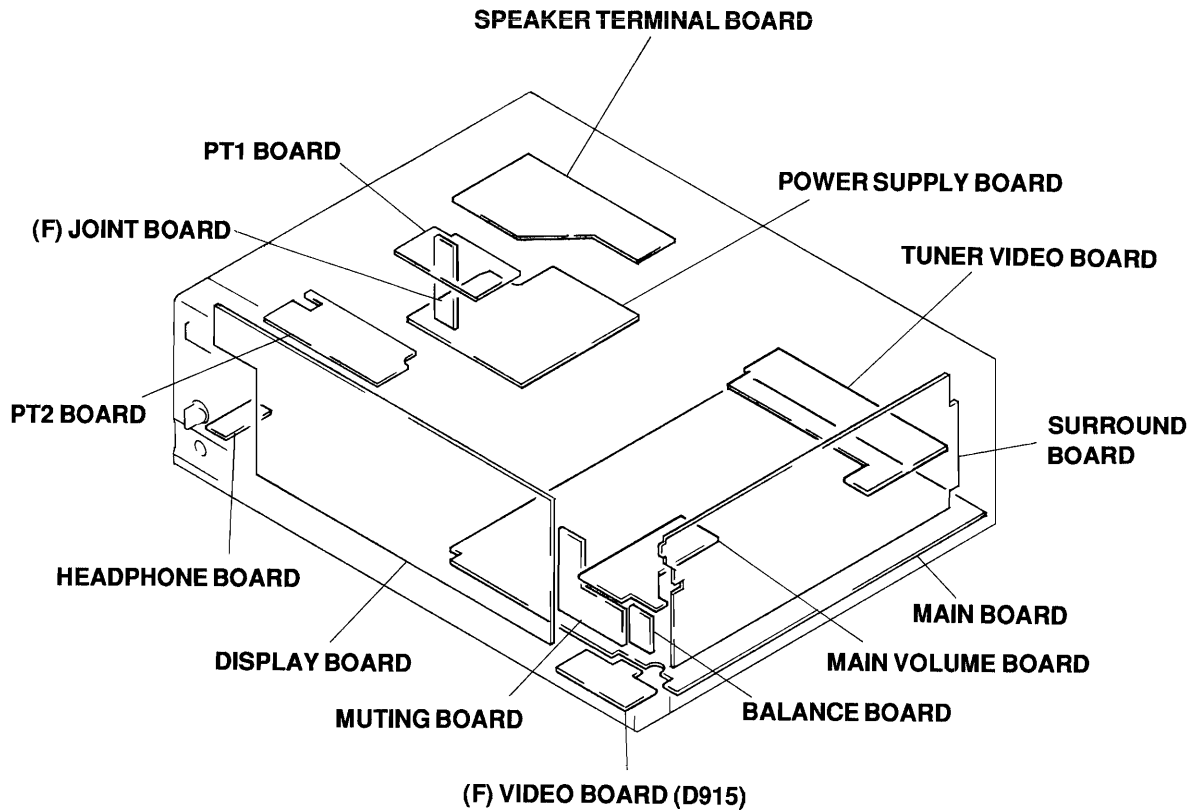

3-2. SEMICONDUCTOR LEAD LAYOUTS

GP1U58XB

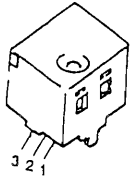

M5F78M05L
TA78M12S

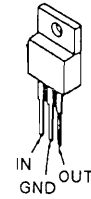

STK3102-MK3

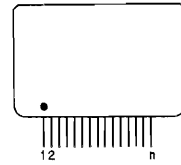

MN2488-OPY-M
MN1620-OPY-M
2SB1560-OPY-M
2SD2390-OPY-M

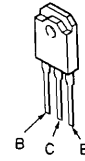

2SD774-34
2SD809-K



RBA-402
RBV-602-01

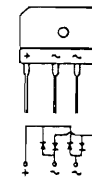

LA2785



M5F79M12L

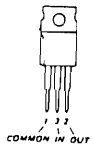

TC9174P

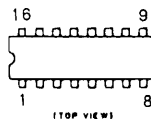

2SA988-PAFAEA

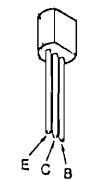

2SK246-GR3



1S1585
1N4148M

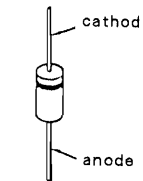

LB1639
M5218AP

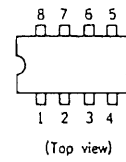

SI-18752

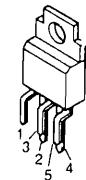

TD62C950RF

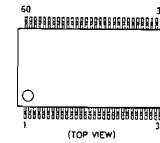

2SA1175-HFE

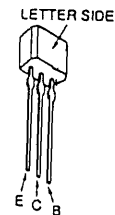

HZS4ALL
HZS6C3L
UZL-9H3
UZL-36H
UZP-5.6B
11ES2

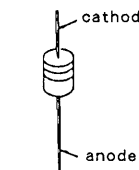

LC7822

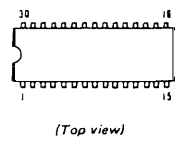

SN74HC151AN
SN74HC237AN
SN761200N
TC9184P

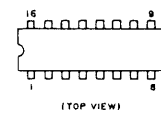

uPD75518GF-195-3B9

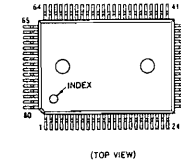

2SC1841-PAFAEA



SEL2210S-CD

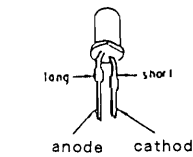

LV1010N

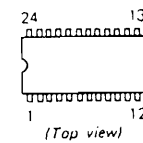

STK350-130

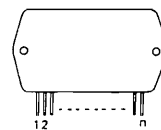

DTA114ES
DTA124ES
DTC114ES
DTC124ES
2SC2785-FEK
2SC3623A-LK



2SC4495
2SD2012

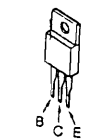

SEL2810A

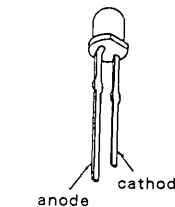

3-3. PRINTED WIRING BOARDS — SURROUND SECTION —
 • See page 7 for Circuit Boards Location.
 • See page 8 for Semiconductor Lead Layouts.

• Semiconductor Location

Ref. No.	Location
D201	B-14
D202	B-13
D204	B-13
D205	E-14
'2	B-10
'7	B-6
I...01	C-10
IC202	C-13
IC251	I-16
IC300	C-8
IC301	E-8
IC302	C-6
IC401	E-3
IC412	B-3
Q201	D-14
Q202	D-14
Q210	E-14
Q211	E-13
Q212	E-13
Q213	B-10
Q251	J-17
Q252	H-17
Q253	G-17
Q254	I-17
Q305	A-4
Q306	C-4
Q307	C-5
Q308	D-5
Q401	A-3
Q402	B-2
Q403	E-4
Q404	D-4
Q451	C-3
Q452	C-2
Q453	F-5
Q454	F-4
Q808	B-6

Note:
 • ○ : parts extracted from the component side.
 • ■ : Pattern from the side which enable seeing.

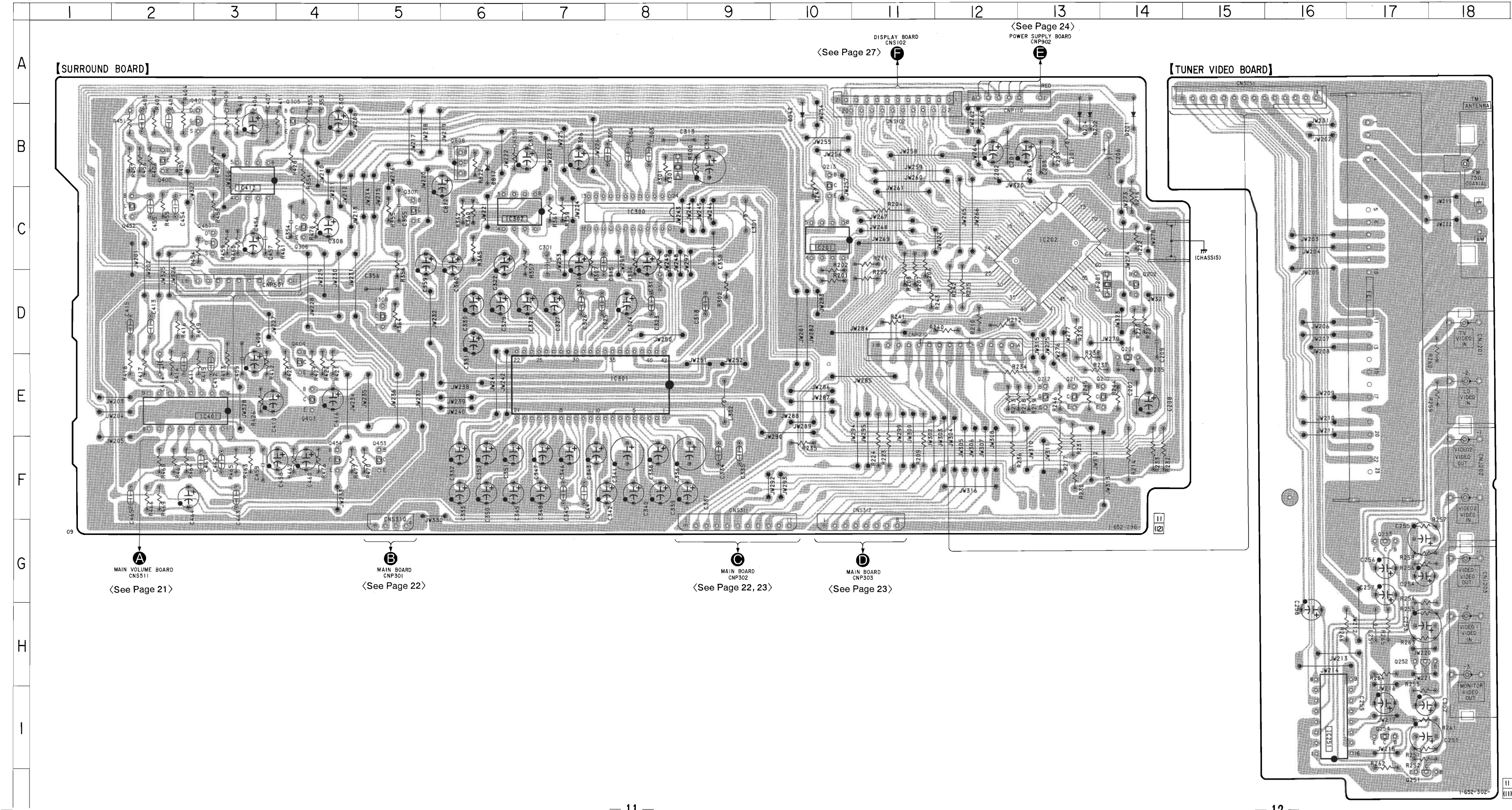

3-4. SCHEMATIC DIAGRAM — SURROUND SECTION —
• See page 34 for IC Pin Functions. (IC202)

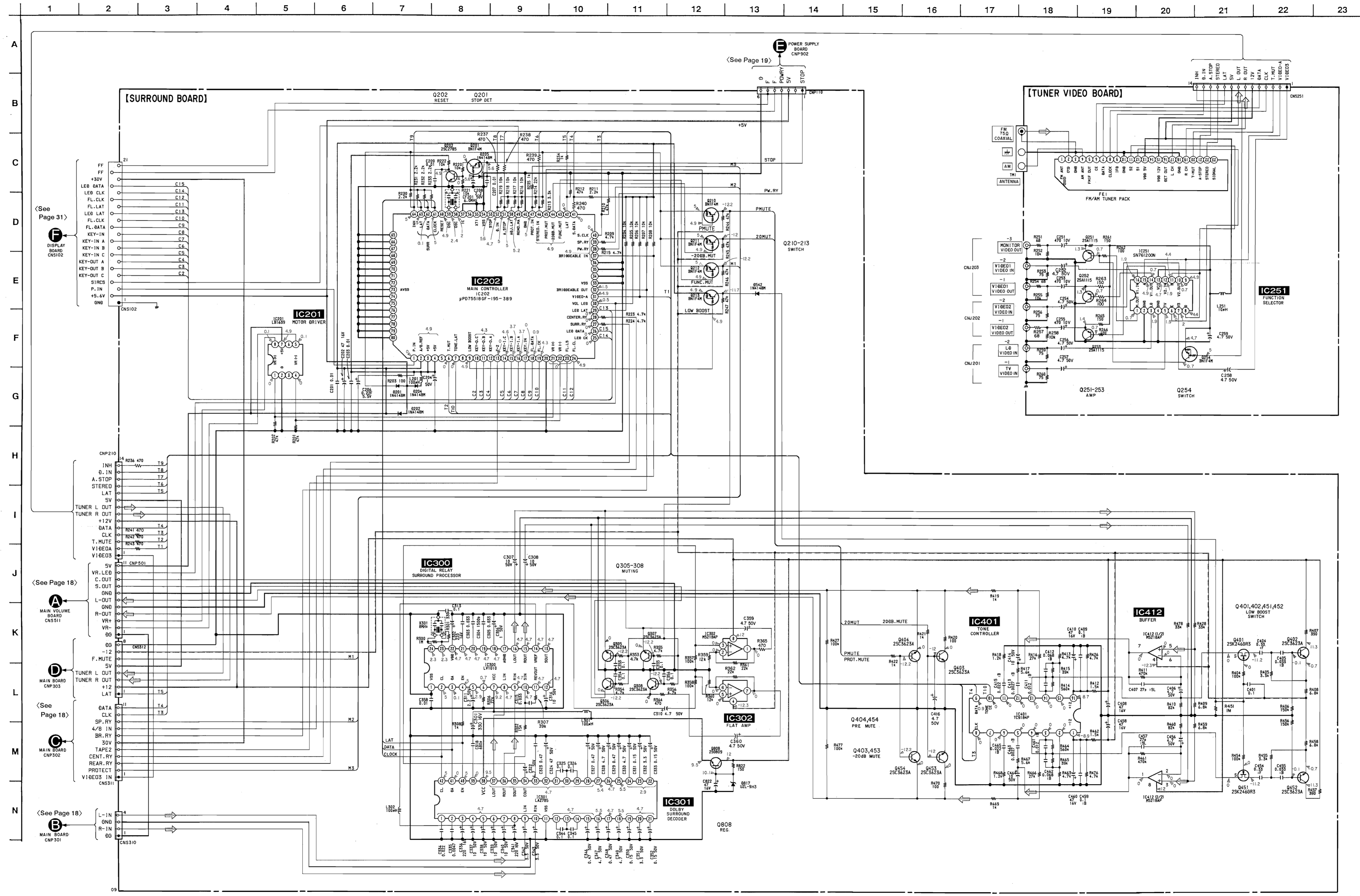

(See Page 31)

DISPLAY BOARD CNS102

(See Page 18)

MAIN VOLUME BOARD CNS11

MAIN BOARD CNS3

MAIN BOARD CNS102

MAIN BOARD CNS301

Note:

- All capacitors are in μF unless otherwise noted. pF ; μF 50WV or less are not indicated except for electrolytics and tantalums.
- All resistors are in Ω and 1/4W or less unless otherwise specified.
- Δ : internal component.
- \square : panel designation.

Note:

The components identified by mark Δ or dotted line with mark Δ are critical for safety. Replace only with part number specified.

Note:

Les composants identifiés par une marque Δ sont critiques pour la sécurité. Ne les remplacer que par une pièce portant le numéro spécifié.

—: B+ Line
-: B- Line

Voltage and waveforms are dc with respect to ground under no-signal conditions.

no mark: FM

Voltages are taken with a VOM (Input impedance 10M Ω). Voltage variations may be noted due to normal production tolerances.

Signal path.

\Rightarrow : FM

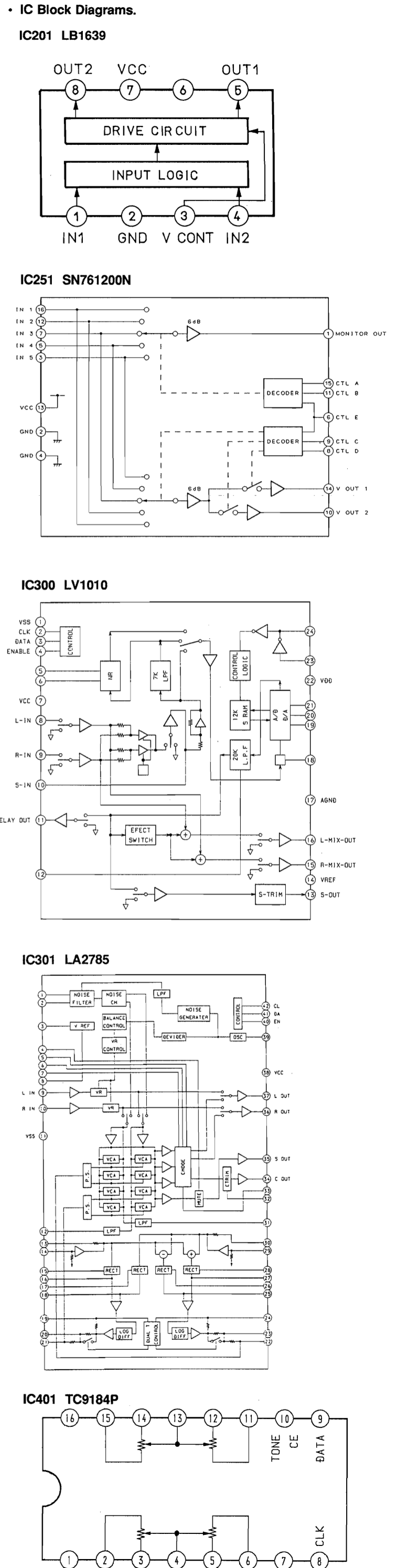

3-5. SCHEMATIC DIAGRAM — MAIN SECTION —

• IC Block Diagrams.

IC502, 503 LC7822

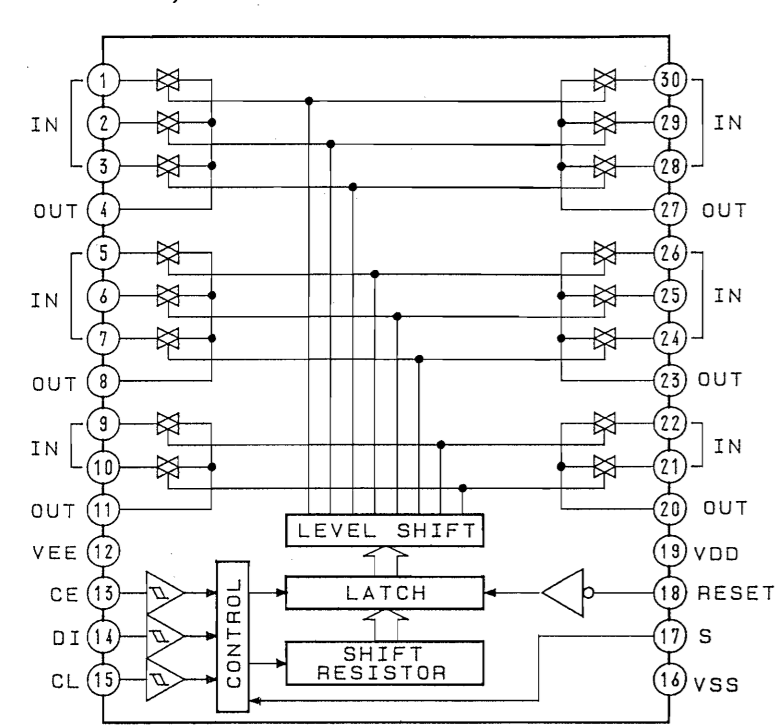

IC601 STK350-130

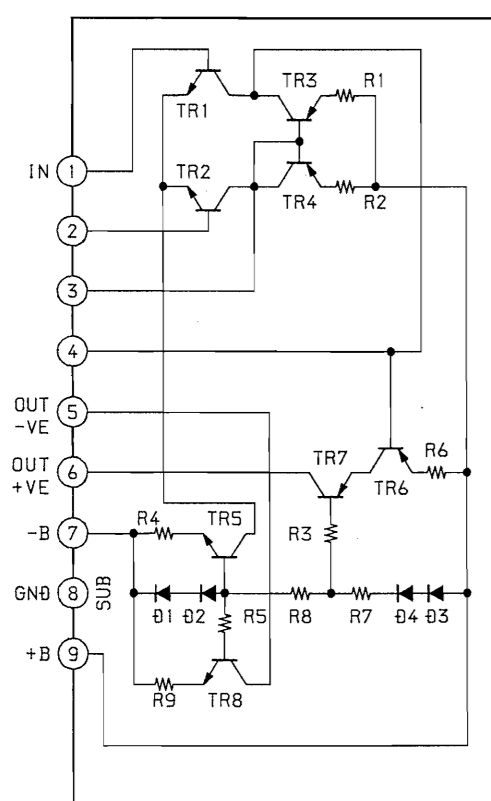

IC701 STK3102-3

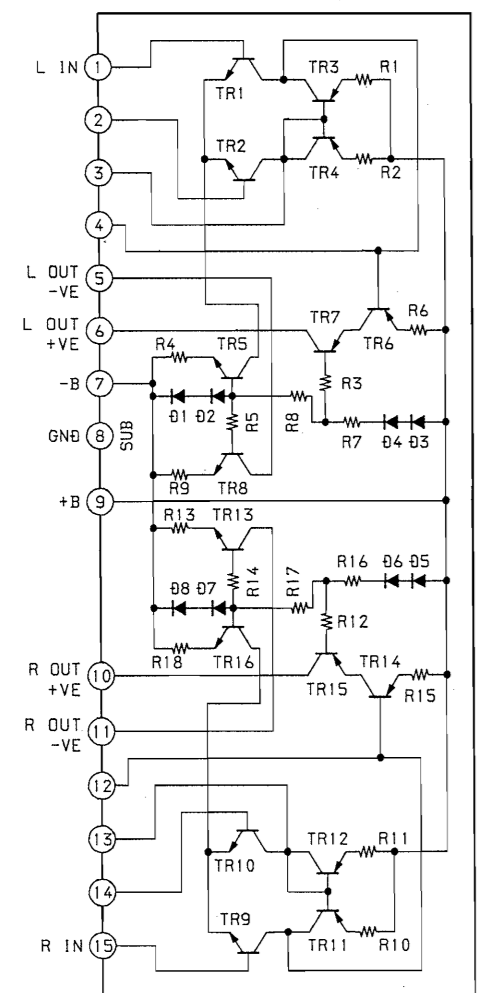

Note: All capacitors are in μF unless otherwise noted. pF=μF/100. 50WV or less are not indicated except for electrolytics and tantalums. All resistors are in Ω and 1/4W or less unless otherwise specified. Δ: internal component. □: nonflammable resistor. □: panel designation. Note: Les composants identifiés par une marque Δ sont critiques pour la sécurité. Ne les remplacer que par une pièce portant le numéro spécifié. Note: The components identified by mark Δ or dotted line with mark Δ are critical for safety. Replace only with part number specified. Note: Les composants identifiés par une marque Δ sont critiques pour la sécurité. Ne les remplacer que par une pièce portant le numéro spécifié.

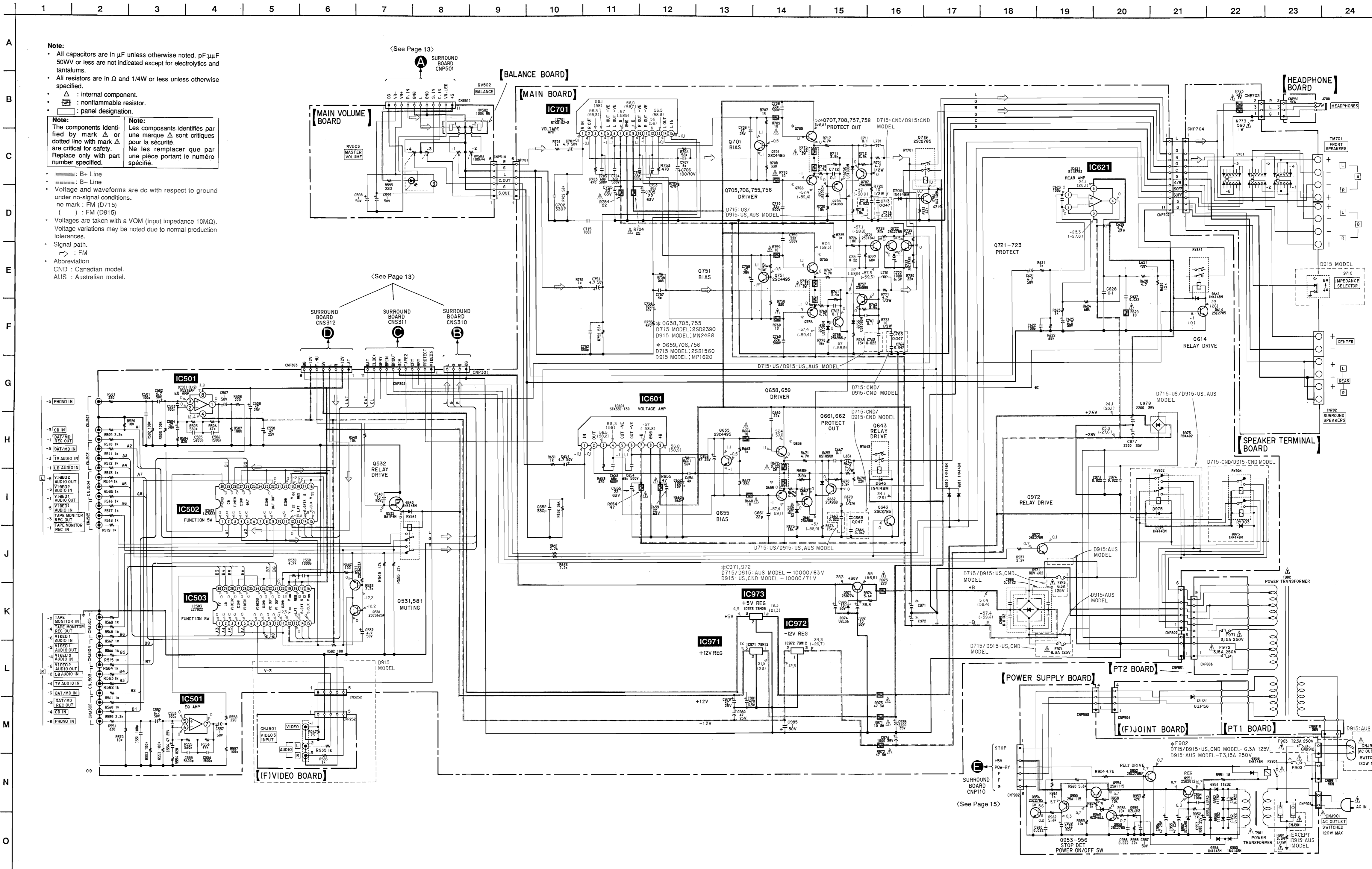

3-6. PRINTED WIRING BOARDS — MAIN SECTION —

- See page 7 for Circuit Boards Location.
- See page 8 for Semiconductor Lead Layouts.

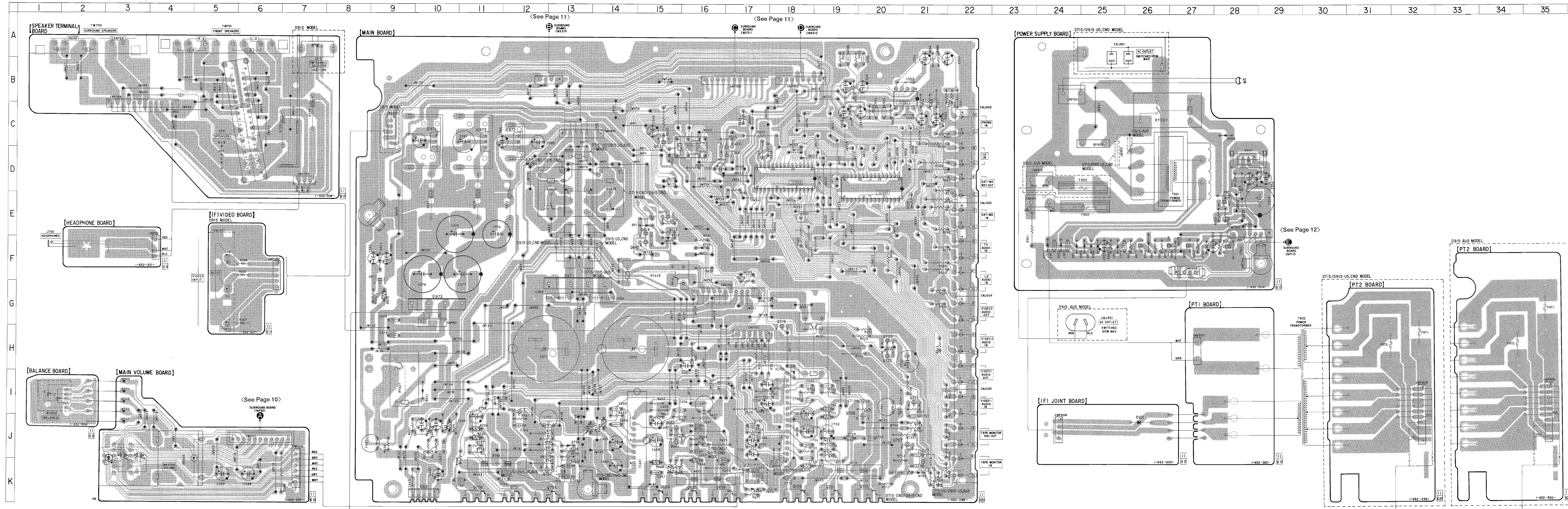

• Semiconductor Location

Ref. No.	Location	Ref. No.	Location
D101	J-26	IC972	C-12
D540	D-15	IC973	C-11
D641	I-10		
D645	F-14	Q531	C-17
D652	J-16	Q532	C-15
D653	K-17	Q581	D-17
D703	K-21	Q614	E-15
D704	J-20	Q643	F-14
D705	F-16	Q655	K-16
D706	H-18	Q658	K-17
D753	J-13	Q659	K-15
D754	J-13	Q661	J-15
D910	E-15	Q662	J-15
D911	E-15	Q701	K-19
D951	F-24	Q705	K-20
D952	F-24	Q706	K-18
D953	F-24	Q707	J-21
D954	F-25	Q708	J-19
D955	F-25	Q719	G-18
D956	F-25	Q721	I-21
D957	D-29	Q722	H-20
D958	C-28	Q723	H-20
D959	F-25	Q751	K-12
D960	F-26	Q755	K-13
D971	F-13	Q756	K-11
D973	G-10	Q757	K-13
D974	F-9	Q758	I-12
D975	C-13	Q951	D-28
		Q952	E-28
		Q953	F-26
		Q954	F-27
		Q955	F-27
		Q956	F-28
		Q971	F-9
		Q972	E15
IC501	B-21		
IC502	D-20		
IC503	D-18		
IC601	K-15		
IC621	K-10		
IC701	I-18		
IC971	C-10		

Note:
 ○ : parts extracted from the component side.
 ◐ : Pattern from the side which enable seeing.
 • Abbreviation
 CND : Canadian model.
 AUS : Australian model.

3-7. PRINTED WIRING BOARDS — DISPLAY SECTION —
 • See page 7 for Circuit Boards Location.
 • See page 8 for Semiconductor Lead Layouts.

• Semiconductor Location

Ref. No.	Location
D101	B-15
D102	B-16
D105	F-18
D106	D-6
D107	D-6
D108	D-6
D109	D-3
D110	D-2
D111	D-16
D121	C-18
D122	C-18
D123	C-18
D124	C-18
D125	C-17
D126	B-17
D127	C-17
D131	D-8
D135	D-8
D138	C-8
IC101	D-12
IC102	D-16
IC103	B-17
IC104	B-10
IC105	F-18
IC106	E-5
Q101	B-15
Q102	B-14

Note:
 •  : Pattern from the side which enable seeing.
 • Abbreviation
 AUS : Australian model.

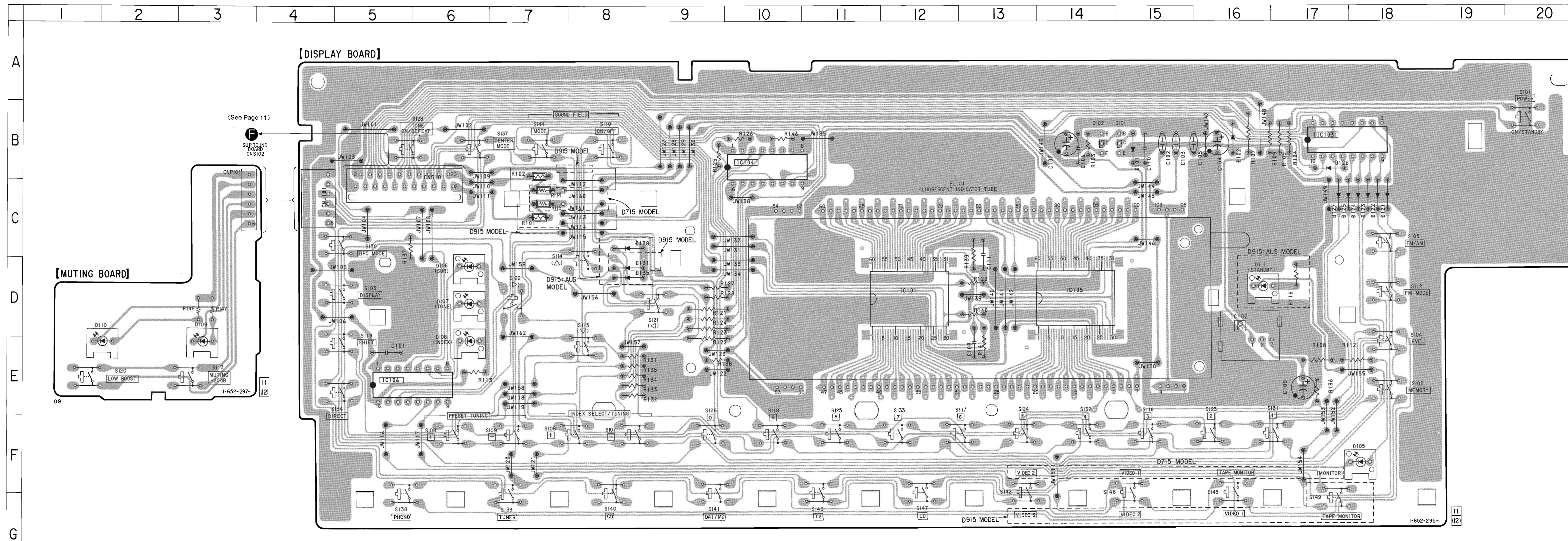

3-8. SCHEMATIC DIAGRAM — DISPLAY SECTION —
 • See page 36 for IC Pin Functions. (IC106)

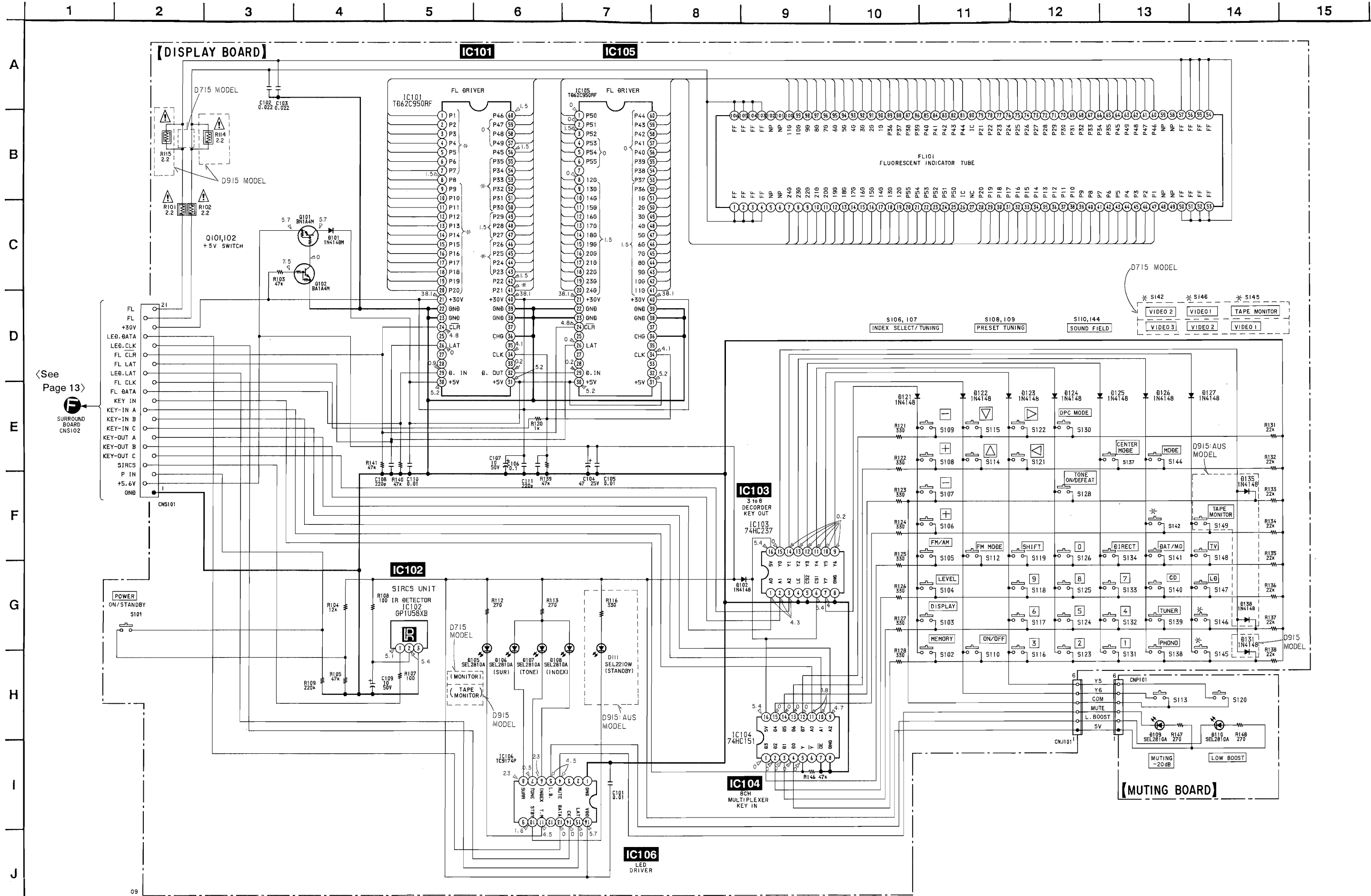

• IC Block Diagrams.

IC103 74HC237

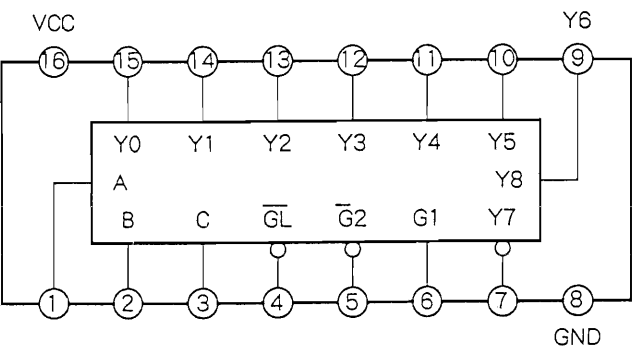

IC104 74HC151

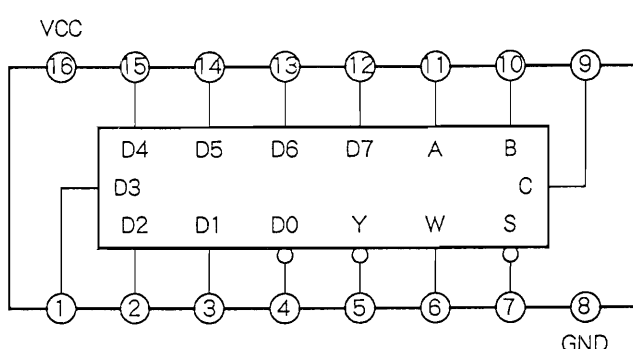

Note:

- All capacitors are in μF unless otherwise noted. $\text{pF}; \mu\text{F}; \mu\text{F}$ 50WV or less are not indicated except for electrolytics and tantalums.
- All resistors are in Ω and 1/4W or less unless otherwise specified.
- \square : nonflammable resistor.
- \square : panel designation.

Note: The components identified by mark Δ or dotted line with mark Δ are critical for safety. Replace only with part number specified.

Note: Les composants identifiés par une marque Δ sont critiques pour la sécurité. Ne les remplacer que par une pièce portant le numéro spécifié.

- --- : B+ Line
- Voltage and waveforms are dc with respect to ground under no-signal conditions. no mark : FM
- \times : can not be measured.
- Voltages are taken with a VOM (input impedance 10M Ω). Voltage variations may be noted due to normal production tolerances.
- Abbreviation AUS : Australian model.

3-9. IC PIN FUNCTIONS

• IC202 (μ PD75518GF-195-3B9) MAIN CONTROLLER

Pin No.	Pin Name	I/O	Function
1	P. IN	I	POWER IN
2	A/D. REF	—	REFERENCE VOLTAGE OF A/D CONVERTER (+5V)
3	+5V	—	+5V
4	+5V	—	+5V
5	—	O	OPEN
6	T. MUT	O	TUNER MUTE
7	TONE. LAT	O	TONE latch
8	—	O	OPEN
9	LOW BOOST	O	LOW BOOST ON/OFF
10	KEY-O. C	O	KEY OUT CONTROL A0
11	KEY-O. B	O	KEY OUT CONTROL A1
12	KEY-O. A	O	KEY OUT CONTROL A2
13	T-2	O	TAPE MONITOR ON/OFF
14	KEY-I. C	O	KEY IN CONTROL A0
15	KEY-I. B	O	KEY IN CONTROL A1
16	KEY-I. A	O	KEY IN CONTROL A2
17	KEY. IN	I	KEY INPUT
18	FL. DATA	O	FL DRIVER SERIAL DATA
19	FL. CK	O	FL DRIVER SERIAL CLOCK
20	—	O	GND
21	VR (+)	O	VOLUME UP control
22	VR (-)	O	VOLUME DOWN control
23	FL. LS	O	FL DRIVER LATCH
24	FL. CL	O	FL DRIVER CLEAR
25	LED CK	O	LED clock
26	LED DATA	O	LED data
27	SURR. RY	O	SURROUND RELAY drive
28	CENTER. RY	O	CENTER RELAY drive
29	LED LAT	O	LED latch (PULL-UP: 2.2k)
30	VOL LED	O	VOLUME LED drive (PULL-UP: 2.2k)
31	VIDEO-A	O	VIDEO A SELECT (PULL-UP: 2.2k)
32	BRIDGEABLE OUT	O	SP=8 Ω : 2CH \rightarrow "L", SURR \rightarrow "H"/SP=4 Ω : ALL "H" (PULL-UP: 2.2k)
33	Vss	—	GND
34	—	I	GND (PULL-UP: 2.2k)
35	—	I	GND (PULL-UP: 2.2k)
36	—	I	GND (PULL-UP: 2.2k)
37	BRIDGEABLE IN	I	SP4 Ω /8 Ω SELECT4 Ω = "L" 8 Ω = "H" (PULL-UP: 2.2k)
38	PW. RY	O	POWER RELAY drive
39	SP. RY	O	SPEAKER RELAY drive
40	S. CLK	O	SERIAL CLOCK

Pin No.	Pin Name	I/O	Function
41	S. DATA	O	SERIAL DATA
42	LAT	O	SERIAL LATCH
43	FUNC. MUT	O	FUNCTION MUTE
44	-20DB. MUT	O	-20dB MUTE
45	PROT. MUT	O	PROTECTOR MUTE (Use a things S-MUTE)
46	STEREO. IN	I	TUNER STEREO SIGNAL INPUT (PULL-UP: 10k)
47	PROT. IN	I	PROTECTOR INPUT (PULL-UP: 10k)
48	GND	--	GND (PULL-UP: 10k)
49	REMO. MA	I	REMOTE CONTROL INPUT (PULL-UP: 10k)
50	ADJ. LAT	I	AUTO MEASUREMENT LATCH (PULL-UP: 10k)
51	A. STOP	I	TUNER AUTO STOP (PULL-UP: 10k)
52	D. IN	I	IF COUNT DATA INPUT (PULL-UP: 10k)
53	STOP	I	STOP DETECT
54	Vss	--	GND
55	XT1	--	GND
56	--	--	OPEN
57	IC	--	GND
58	OSC	--	CRYSTAL OSCILLATOR 6MHz
59	OSC	--	CRYSTAL OSCILLATOR 6MHz
60	RESET	I	RESET INPUT
61	SURR CLOCK	O	Serial clock for surround IC (LV1010, LA2785) (PULL-UP: 2.2k)
62	SURR DATA	O	Serial data for surround IC (LV1010, LA2785) (PULL-UP: 2.2k)
63	SURR LAT	O	Serial latch for surround IC (LV1010, LA2785) (PULL-UP: 2.2k)
64	INH	O	Inhibit output for VIDEO MONITOR OUT (PULL-UP: 2.2k)
65	--	I	GND
66	--	I	GND
67	--	I	GND
68	--	I	GND
69	--	I	GND
70	--	I	GND
71	--	I	GND
72	--	I	GND
73	Vss	--	GND
74	--	I	GND
75	--	I	GND
76	--	I	GND
77	--	I	GND
78	--	I	GND
79	--	I	GND
80	--	I	GND

• IC106 (TC9174P) LED DRIVER

Pin No.	Pin Name	I/O	Function
1	GND	—	GND
2	NC	—	Not used
3	NC	—	Not used
4	MUTE	O	MUTING LED drive
5	L.B.	O	LOW BOOST LED drive
6	INDEX	O	INDEX LED drive
7	TONE	O	TONE LED drive
8	SURR	O	SUR LED drive
9	NC	—	Not used
10	STBY	O	STANDBY LED drive (D915: Australian model)
11	T.M	O	MONITOR LED (D715), TAPE MONITOR LED (D915) drive
12	NC	—	Not used
13	DATA	I	Serial data input
14	CK	I	Serial clock input
15	LAT	I	Serial latch input
16	VDD	—	+5.6V

SECTION 4 EXPLODED VIEWS

NOTE:

- Items marked “ * ” are not stocked since they are seldom required for routine service. Some delay should be anticipated when ordering these items.
- -XX, -X mean standardized parts, so they may have some difference from the original one.

- The mechanical parts with no reference number in the exploded views are not supplied.
- Hardware (# mark) list and accessories and packing materials are given in the last of this parts list.
- Abbreviation
 CND : Canadian model
 AUS : Australian model

The components identified by mark Δ or dotted line with mark Δ are critical for safety. Replace only with part number specified.

Les composants identifiés par une marque Δ sont critiques pour la sécurité. Ne les remplacer que par une pièce portant le numéro spécifié.

4-1. CABINET SECTION

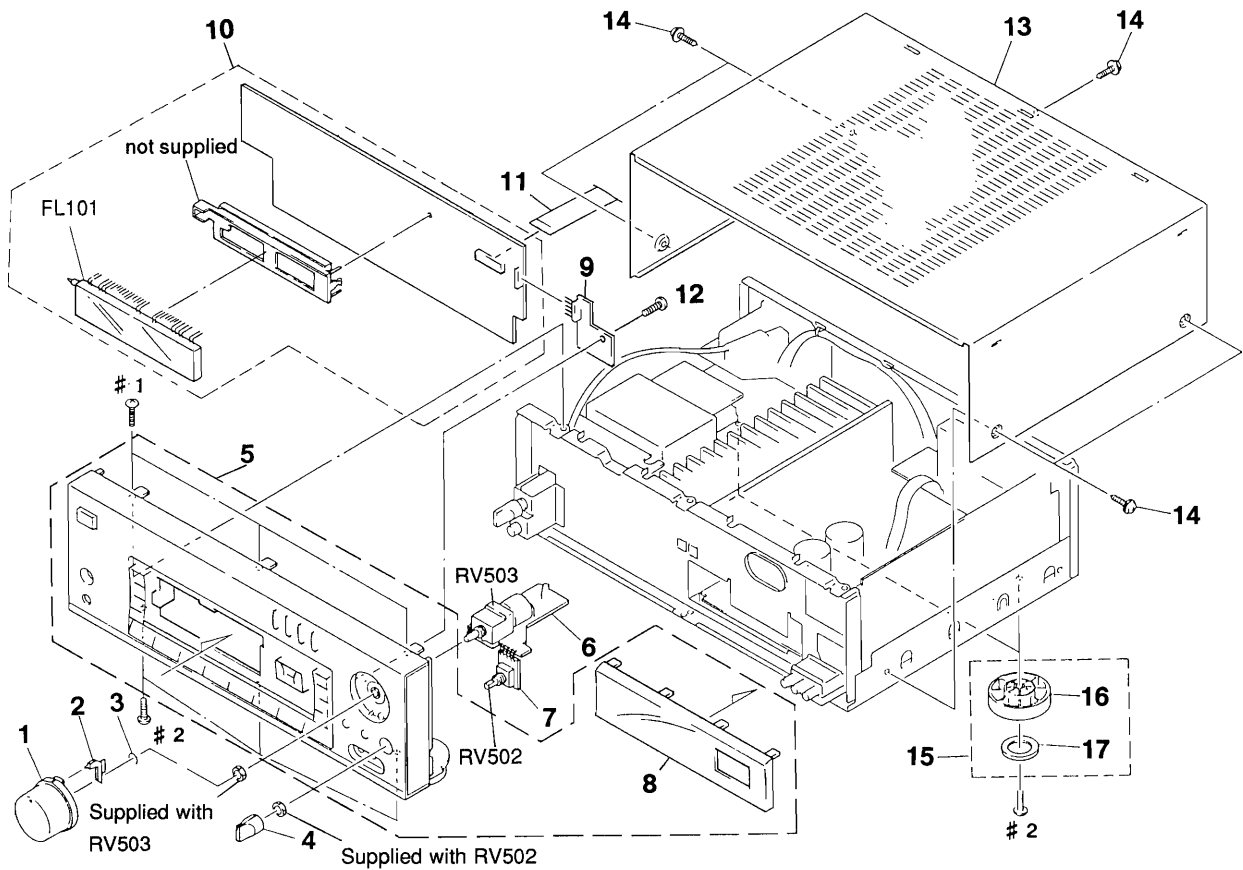

Ref. No.	Part No.	Description	Remark	Ref. No.	Part No.	Description	Remark
1	4-949-659-01	KNOB (VOL-NEW)		* 10	A-4369-964-A	DISPLAY BOARD, COMPLETE (D915:AUS)	
2	4-958-991-01	PLATE (VOL), LIGHT GUIDE		* 10	A-4369-969-A	DISPLAY BOARD, COMPLETE (D715)	
3	3-350-426-01	SPRING, RING		11	1-765-290-11	WIRE (FLAT TYPE) (21 CORE)	
4	4-957-383-01	KNOB (F14)		12	4-951-620-01	SCREW (2. 6X8), +BVTP	
5	X-4944-830-1	PANEL ASSY, FRONT (D915:US, CND)		13	4-931-031-11	CASE	
5	X-4944-831-1	PANEL ASSY, FRONT (D915:AUS)		14	3-704-366-01	SCREW (CASE) (M3X8)	
5	X-4944-832-1	PANEL ASSY, FRONT (D715)		15	X-4941-291-1	FOOT ASSY (F58175S) (EXCEPT D915:AUS)	
* 6	1-652-305-11	MAIN VOLUME BOARD		15	X-4941-292-1	FOOT ASSY (F58175S) (D915:AUS)	
* 7	1-652-306-11	BALANCE BOARD		16	3-318-688-31	FOOT (F58175S) (D915:AUS)	
8	4-965-948-01	PLATE (B), INDICATION (EXCEPT D915:AUS)		16	3-318-688-51	FOOT (F58175S) (EXCEPT D915:AUS)	
8	4-965-948-11	PLATE (B), INDICATION (D915:AUS)		17	4-923-836-21	CUSHION	
* 9	1-652-297-11	MUTING BOARD		FL101	1-517-305-11	INDICATOR TUBE, FLUORESCENT	
* 10	A-4369-963-A	DISPLAY BOARD, COMPLETE (D915:US, CND)					

4-2. CHASSIS SECTION

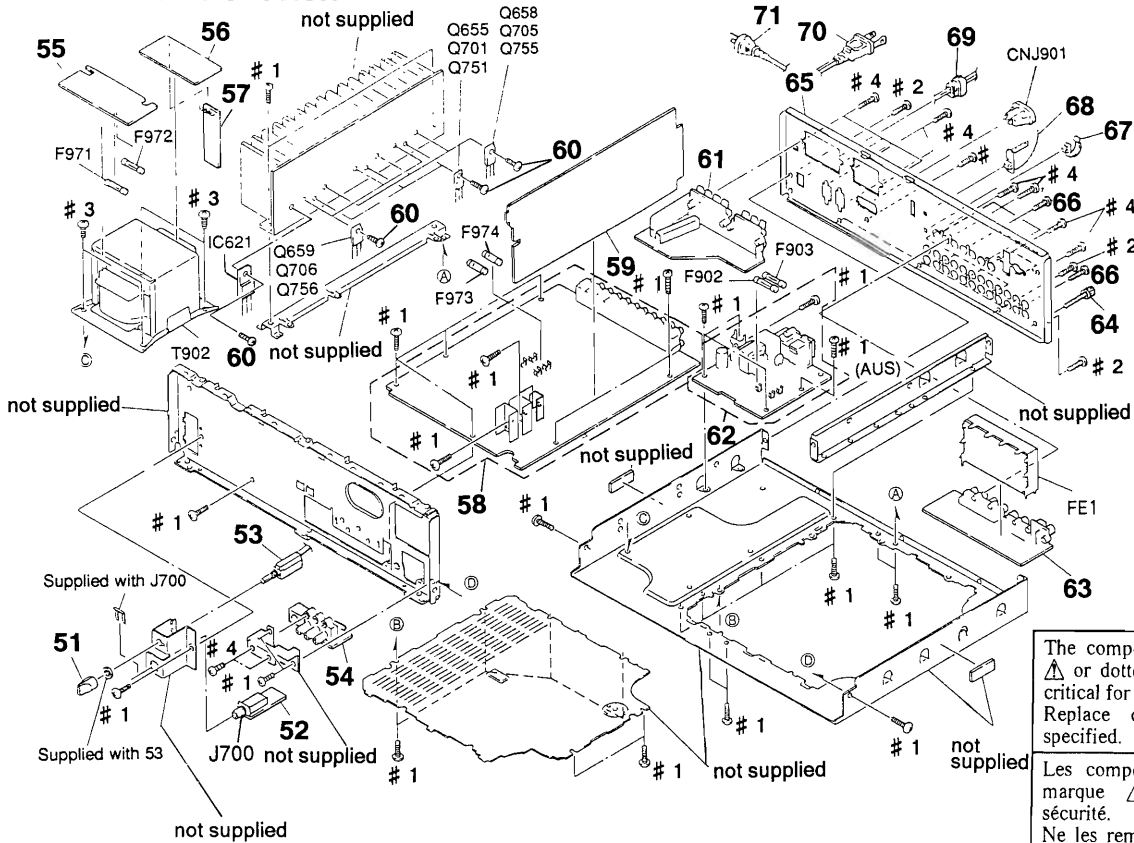

The components identified by mark \triangle or dotted line with mark \triangle are critical for safety. Replace only with part number specified.

Les composants identifiés par une marque \triangle sont critiques pour la sécurité. Ne les remplacer que par une pièce portant le numéro spécifié.

Ref. No.	Part No.	Description	Remark	Ref. No.	Part No.	Description	Remark
51	4-957-383-01	KNOB (F14)		\triangle F902	1-532-748-11	FUSE, GLASS TUBE (6.3A/125V)	(EXCEPT D915:AUS)
* 52	1-652-301-11	HEADPHONE BOARD		\triangle F903	1-532-286-00	FUSE (T2.5A/250V) (D915:AUS)	
53	1-572-291-41	SWITCH, ROTARY SLIDE		\triangle F971	1-532-237-00	FUSE, TIME LAG (T3.15A/250V) (D915:AUS)	
* 54	1-652-307-11	(F) VIDEO BOARD (D915)		\triangle F971	1-576-107-11	FUSE (3.15A/250V) (EXCEPT D915:AUS)	
* 55	1-652-299-11	PT2 BOARD (EXCEPT D915:AUS)		\triangle F972	1-532-237-00	FUSE, TIME LAG (T3.15A/250V) (D915:AUS)	
* 55	1-652-300-11	PT2 BOARD (D915:AUS)		\triangle F972	1-576-107-11	FUSE (3.15A/250V) (EXCEPT D915:AUS)	
* 56	1-652-303-11	PT1 BOARD		\triangle F973	1-532-748-11	FUSE, GLASS TUBE (6.3A/125V)	(EXCEPT D915:AUS)
* 57	1-652-309-11	(F) JOINT BOARD		\triangle F974	1-532-748-11	FUSE, GLASS TUBE (6.3A/125V)	(EXCEPT D915:AUS)
* 58	A-4369-953-A	MAIN BOARD, COMPLETE (D915:US)		FE1	1-239-727-11	ENCAPSULATED COMPONENT (FCC)	(EXCEPT D915:AUS)
* 58	A-4369-962-A	MAIN BOARD, COMPLETE (D915:CND)		FE1	1-239-611-11	ENCAPSULATED COMPONENT (D915:AUS)	
* 58	A-4369-971-A	MAIN BOARD, COMPLETE (D715:US)		IC621	8-759-502-33	IC SI-18752	
* 58	A-4369-973-A	MAIN BOARD, COMPLETE (D715:CND)		Q655	8-729-026-08	TRANSISTOR 2SC4495	
* 58	A-4371-665-A	MAIN BOARD, COMPLETE (D915:AUS)		Q658	8-729-022-16	TRANSISTOR 2SD2390-OPY-M (D715)	
* 59	A-4369-951-A	SURROUND BOARD, COMPLETE		Q658	8-749-010-25	TRANSISTOR MN2488-OPY-M (D915)	
60	3-905-609-01	SCREW (TRANSISTOR)		Q659	8-729-022-15	TRANSISTOR 2SB1560-OPY-M (D715)	
* 61	1-652-308-11	SPEAKER TERMINAL BOARD		Q659	8-749-010-26	TRANSISTOR MP1620-OPY-M (D915)	
* 62	A-4369-957-A	POWER SUPPLY BOARD, COMPLETE	(EXCEPT D915:AUS)	Q701	8-729-026-08	TRANSISTOR 2SC4495	
* 62	A-4369-966-A	POWER SUPPLY BOARD, COMPLETE (D915:AUS)		Q705	8-729-022-16	TRANSISTOR 2SD2390-OPY-M (D715)	
* 63	1-652-302-11	TUNER VIDEO BOARD		Q705	8-749-010-25	TRANSISTOR MN2488-OPY-M (D915)	
64	4-947-010-01	SCREW, FEEDER FIXED		Q706	8-729-022-15	TRANSISTOR 2SB1560-OPY-M (D715)	
* 65	4-965-957-01	PANEL, BACK (D915:US)		Q706	8-749-010-26	TRANSISTOR MP1620-OPY-M (D915)	
* 65	4-965-957-11	PANEL, BACK (D915:CND)		Q751	8-729-026-08	TRANSISTOR 2SC4495	
* 65	4-965-957-21	PANEL, BACK (D915:AUS)		Q755	8-729-022-16	TRANSISTOR 2SD2390-OPY-M (D715)	
* 65	4-965-957-31	PANEL, BACK (D715:US)		Q755	8-749-010-25	TRANSISTOR MN2488-OPY-M (D915)	
* 65	4-965-957-41	PANEL, BACK (D715:CND)		Q756	8-729-022-15	TRANSISTOR 2SB1560-OPY-M (D715)	
66	3-704-515-01	SCREW (BV/RING)		Q756	8-749-010-26	TRANSISTOR MP1620-OPY-M (D915)	
* 67	4-949-235-01	HOOK (EXCEPT D915:AUS)		\triangle T902	1-423-637-11	TRANSFORMER, POWER (D715:US)	
68	4-956-370-12	BAND, PLUG FIXED (D915:AUS)		\triangle T902	1-423-638-11	TRANSFORMER, POWER (D715:CND)	
* 69	3-703-244-00	BUSHING (2104), CORD		\triangle T902	1-426-756-11	TRANSFORMER, POWER (D915:US)	
\triangle 70	1-690-609-11	CORD, POWER (EXCEPT D915:AUS)		\triangle T902	1-426-757-11	TRANSFORMER, POWER (D915:CND)	
\triangle 71	1-696-848-21	CORD, POWER (D915:AUS)		\triangle T902	1-426-758-11	TRANSFORMER, POWER (D915:AUS)	
\triangle CNJ901	1-251-078-11	OUTLET, AC. (D915:AUS)					
\triangle F902	1-532-237-00	FUSE, TIME LAG (T3.15A/250V) (D915:AUS)					

SECTION 5 ELECTRICAL PARTS LIST

BALANCE

DISPLAY

NOTE:

The components identified by mark Δ or dotted line with mark Δ are critical for safety.
Replace only with part number specified.

Les composants identifiés par une marque Δ sont critiques pour la sécurité.
Ne les remplacer que par une pièce portant le numéro spécifié.

When indicating parts by reference number, please include the board name.

- Due to standardization, replacements in the parts list may be different from the parts specified in the diagrams or the components used on the set.
- Items marked "*" are not stocked since they are seldom required for routine service. Some delay should be anticipated when ordering these items.
- -XX, -X mean standardized parts, so they may have some difference from the original one.
- Hardware (# mark) list and accessories and packing materials are given in the last of this parts list.
- Abbreviation
CND : Canadian model
AUS : Australian model

- RESISTORS
All resistors are in ohms
METAL: Metal-film resistor
METAL OXIDE: Metal Oxide-film resistor
F : nonflammable
- SEMICONDUCTORS
In each case, u: μ , for example:
uA...: μ A..., uPA...: μ PA...,
uPB...: μ PB..., uPC...: μ PC...,
uPD...: μ PD...
- CAPACITORS
uF : μ F
- COILS
uH : μ H

Ref. No.	Part No.	Description	Remark	Ref. No.	Part No.	Description	Remark
*	1-652-306-11	BALANCE BOARD *****		D122	8-719-987-63	DIODE 1N4148M	
		< VARIABLE RESISTOR >		D123	8-719-987-63	DIODE 1N4148M	
	RV502 1-238-965-21	RES, VAR, CARBON 100K/100K (BALANCE)		D124	8-719-987-63	DIODE 1N4148M	

*	A-4369-963-A	DISPLAY BOARD, COMPLETE (D915:US, CND) *****		D125	8-719-987-63	DIODE 1N4148M	
*	A-4369-964-A	DISPLAY BOARD, COMPLETE (D915:AUS) *****		D126	8-719-987-63	DIODE 1N4148M	
*	A-4369-969-A	DISPLAY BOARD, COMPLETE (D715) *****		D127	8-719-987-63	DIODE 1N4148M	
		< CAPACITOR >		D131	8-719-987-63	DIODE 1N4148M (D915)	
C101	1-161-379-00	CERAMIC 0.01uF 20% 25V		D135	8-719-987-63	DIODE 1N4148M (D915:AUS)	
C102	1-164-097-11	CERAMIC 0.022uF 50V		D138	8-719-987-63	DIODE 1N4148M (D915:AUS)	
C103	1-164-097-11	CERAMIC 0.022uF 50V		< FLUORESCENT INDICATOR >			
C104	1-124-477-11	ELECT 47uF 20% 25V		FL101	1-517-305-11	INDICATOR TUBE, FLUORESCENT	
C105	1-164-096-11	CERAMIC 0.01uF 50V				< IC >	
C106	1-164-159-11	CERAMIC 0.1uF 50V		IC101	8-759-075-35	IC TD62C950RF	
C107	1-126-795-11	ELECT 10uF 20% 50V		IC102	8-749-923-11	IC GP1U58XB	
C108	1-162-286-31	CERAMIC 220PF 10% 50V		IC103	8-759-921-32	IC SN74HC237AN	
C109	1-126-795-11	ELECT 10uF 20% 50V		IC104	8-759-916-48	IC SN74HC151AN	
C110	1-161-379-00	CERAMIC 0.01uF 20% 25V		IC105	8-759-075-35	IC TD62C950RF	
C111	1-162-286-31	CERAMIC 220PF 10% 50V		IC106	8-759-202-07	IC TC9174P	
		< CONNECTOR >		< TRANSISTOR >			
* CNJ101	1-565-482-11	CONNECTOR, BOARD TO BOARD 6P		Q101	8-729-900-61	TRANSISTOR DTA114ES	
CNS101	1-691-651-11	SOCKET, CONNECTOR 21P		Q102	8-729-900-80	TRANSISTOR DTC114ES	
		< DIODE >		< RESISTOR >			
D101	8-719-987-63	DIODE 1N4148M		Δ R101	1-249-385-11	CARBON 2.2 5% 1/6W F	
D102	8-719-987-63	DIODE 1N4148M		Δ R102	1-249-385-11	CARBON 2.2 5% 1/6W F	
D105	8-719-301-49	LED SEL2810A (MONITOR) (D715)		R103	1-249-437-11	CARBON 47K 5% 1/4W	
D105	8-719-301-49	LED SEL2810A (TAPE MONITOR) (D915)		R104	1-249-430-11	CARBON 12K 5% 1/4W	
D106	8-719-301-49	LED SEL2810A (SUR)		R105	1-249-437-11	CARBON 47K 5% 1/4W	
D107	8-719-301-49	LED SEL2810A (TONE)		R107	1-247-807-31	CARBON 100 5% 1/4W	
D108	8-719-301-49	LED SEL2810A (INDEX)		R108	1-247-807-31	CARBON 100 5% 1/4W	
D111	8-719-301-37	LED SEL2210S-CD (STANDBY) (D915:AUS)		R109	1-247-887-00	CARBON 220K 5% 1/4W	
D121	8-719-987-63	DIODE 1N4148M		R112	1-249-410-11	CARBON 270 5% 1/4W F	
				R113	1-249-410-11	CARBON 270 5% 1/4W F	
				Δ R114	1-249-385-11	CARBON 2.2 5% 1/6W F (D715)	
				Δ R115	1-249-385-11	CARBON 2.2 5% 1/6W F (D715)	
				R116	1-249-411-11	CARBON 330 5% 1/4W (D915:AUS)	
				R120	1-249-417-11	CARBON 1K 5% 1/4W F	
				R121	1-249-411-11	CARBON 330 5% 1/4W	

DISPLAY

(F) JOINT

(F) VIDEO

HEADPHONE

Ref.No.	Part No.	Description	Remark
R122	1-249-411-11	CARBON 330 5% 1/4W	
R123	1-249-411-11	CARBON 330 5% 1/4W	
R124	1-249-411-11	CARBON 330 5% 1/4W	
R125	1-249-411-11	CARBON 330 5% 1/4W	
R126	1-249-411-11	CARBON 330 5% 1/4W	
R127	1-249-411-11	CARBON 330 5% 1/4W	
R128	1-249-411-11	CARBON 330 5% 1/4W	
R131	1-249-433-11	CARBON 22K 5% 1/4W	
R132	1-249-433-11	CARBON 22K 5% 1/4W	
R133	1-249-433-11	CARBON 22K 5% 1/4W	
R134	1-249-433-11	CARBON 22K 5% 1/4W	
R135	1-249-433-11	CARBON 22K 5% 1/4W	
R136	1-249-433-11	CARBON 22K 5% 1/4W	
R137	1-249-433-11	CARBON 22K 5% 1/4W	
R138	1-249-433-11	CARBON 22K 5% 1/4W	
R139	1-249-437-11	CARBON 47K 5% 1/4W	
R140	1-249-437-11	CARBON 47K 5% 1/4W	
R141	1-249-437-11	CARBON 47K 5% 1/4W	
R146	1-249-437-11	CARBON 47K 5% 1/4W	
< SWITCH >			
S101	1-554-303-21	SWITCH, TACTILE (POWER)	
S102	1-554-303-21	SWITCH, TACTILE (MEMORY)	
S103	1-554-303-21	SWITCH, TACTILE (DISPLAY)	
S104	1-554-303-21	SWITCH, TACTILE (LEVEL)	
S105	1-554-303-21	SWITCH, TACTILE (FM/AM)	
S106	1-554-303-21	SWITCH, TACTILE (+)	
S107	1-554-303-21	SWITCH, TACTILE (-)	
S108	1-554-303-21	SWITCH, TACTILE (+)	
S109	1-554-303-21	SWITCH, TACTILE (-)	
S110	1-554-303-21	SWITCH, TACTILE (ON/OFF)	
S112	1-554-303-21	SWITCH, TACTILE (FM MODE)	
S114	1-554-303-21	SWITCH, TACTILE (△)	
S115	1-554-303-21	SWITCH, TACTILE (▽)	
S116	1-554-303-21	SWITCH, TACTILE (3)	
S117	1-554-303-21	SWITCH, TACTILE (6)	
S118	1-554-303-21	SWITCH, TACTILE (9)	
S119	1-554-303-21	SWITCH, TACTILE (SHIFT)	
S121	1-554-303-21	SWITCH, TACTILE (<)	
S122	1-554-303-21	SWITCH, TACTILE (>)	
S123	1-554-303-21	SWITCH, TACTILE (2)	
S124	1-554-303-21	SWITCH, TACTILE (5)	
S125	1-554-303-21	SWITCH, TACTILE (8)	
S126	1-554-303-21	SWITCH, TACTILE (0)	
S128	1-554-303-21	SWITCH, TACTILE (TONE ON/DEFEAT)	
S130	1-554-303-21	SWITCH, TACTILE (DPC MODE)	
S131	1-554-303-21	SWITCH, TACTILE (1)	
S132	1-554-303-21	SWITCH, TACTILE (4)	
S133	1-554-303-21	SWITCH, TACTILE (7)	
S134	1-554-303-21	SWITCH, TACTILE (DIRECT)	
S137	1-554-303-21	SWITCH, TACTILE (CENTER MODE)	

Ref.No.	Part No.	Description	Remark
S138	1-554-303-21	SWITCH, TACTILE (PHONO)	
S139	1-554-303-21	SWITCH, TACTILE (TUNER)	
S140	1-554-303-21	SWITCH, TACTILE (CD)	
S141	1-554-303-21	SWITCH, TACTILE (DAT/MD)	
S142	1-554-303-21	SWITCH, TACTILE (VIDEO2) (D715)	
S142	1-554-303-21	SWITCH, TACTILE (VIDEO3) (D915)	
S144	1-554-303-21	SWITCH, TACTILE (MODE)	
S145	1-554-303-21	SWITCH, TACTILE (TAPE MONITOR) (D715)	
S145	1-554-303-21	SWITCH, TACTILE (VIDEO1) (D915)	
S146	1-554-303-21	SWITCH, TACTILE (VIDEO1) (D715)	
S146	1-554-303-21	SWITCH, TACTILE (VIDEO2) (D915)	
S147	1-554-303-21	SWITCH, TACTILE (LD)	
S148	1-554-303-21	SWITCH, TACTILE (TV)	
S149	1-554-303-21	SWITCH, TACTILE (TAPE MONITOR) (D915)	

*	1-652-309-11	(F) JOINT BOARD	

< CONNECTOR >			
* CNP904	1-565-480-11	CONNECTOR, BOARD TO BOARD 4P	
< DIODE >			
D101	8-719-014-66	DIODE UZP-5.6B	

*	1-652-307-11	(F) VIDEO BOARD (D915)	

< CONNECTOR >			
CNJ501	1-766-206-11	JACK, PIN 3P (VIDEO3 INPUT)	
CNP252	1-766-203-11	PLUG, CONNECTOR PIN (PC BOARD) 5P	
< RESISTOR >			
R267	1-247-804-11	CARBON 75 5% 1/4W	
R535	1-249-417-11	CARBON 1K 5% 1/4W F	
R585	1-249-417-11	CARBON 1K 5% 1/4W F	

*	1-652-301-11	HEADPHONE BOARD	

< JACK >			
J700	1-568-498-31	JACK, LARGE TYPE (HEADPHONES)	

Ref. No.	Part No.	Description	Remark	Ref. No.	Part No.	Description	Remark
*	A-4369-953-A	MAIN BOARD, COMPLETE (D915:US) *****		C656	1-164-040-11	CERAMIC	4PF 0.25PF 50V
*	A-4369-962-A	MAIN BOARD, COMPLETE (D915:CND) *****		C657	1-124-443-00	ELECT	100uF 20% 10V
*	A-4369-971-A	MAIN BOARD, COMPLETE (D715:US) *****		C658	1-124-477-11	ELECT	47uF 20% 25V
*	A-4369-973-A	MAIN BOARD, COMPLETE (D715:CND) *****		C659	1-124-916-11	ELECT	22uF 20% 63V
*	A-4371-665-A	MAIN BOARD, COMPLETE (D915:AUS) *****		C660	1-161-959-00	CERAMIC	22PF 10% 500V
	1-533-217-31	HOLDER, FUSE		C661	1-161-959-00	CERAMIC	22PF 10% 500V
	1-533-233-11	HOLDER, FUSE (D915:US, CND)		C662	1-136-165-00	FILM	0.1uF 5% 50V
	1-533-293-11	FUSE HOLDER		C663	1-136-157-00	FILM	0.022uF 5% 50V
*	4-942-204-01	PLATE, GROUND		C663	1-136-161-00	FILM	0.047uF 5% 50V (D715:US/D915:US, AUS) (D715:CND/D915:CND)
	7-682-548-04	SCREW +BVT 3X8 (S)		C664	1-136-161-00	FILM	0.047uF 5% 50V (D715:CND/D915:CND)
	< CAPACITOR >			C667	1-136-165-00	FILM	0.1uF 5% 50V
C501	1-162-282-31	CERAMIC	100PF 10% 50V	C701	1-124-927-11	ELECT	4.7uF 20% 100V
C502	1-124-927-11	ELECT	4.7uF 20% 100V	C702	1-162-288-31	CERAMIC	330PF 10% 50V
C503	1-162-282-31	CERAMIC	100PF 10% 50V	C703	1-102-989-00	CERAMIC	68PF 5% 500V
C504	1-124-477-11	ELECT	47uF 20% 25V	C704	1-102-989-00	CERAMIC	68PF 5% 500V
C505	1-130-480-00	MYLAR	0.0056uF 5% 50V	C705	1-124-916-11	ELECT	22uF 20% 63V
C506	1-130-473-00	MYLAR	0.0015uF 5% 50V	C706	1-124-443-00	ELECT	100uF 20% 10V
C507	1-124-903-11	ELECT	1uF 20% 50V	C707	1-164-040-11	CERAMIC	4PF 0.25PF 50V
C508	1-124-477-11	ELECT	47uF 20% 25V	C708	1-124-477-11	ELECT	47uF 20% 25V
C530	1-162-294-31	CERAMIC	0.001uF 10% 50V	C709	1-161-959-00	CERAMIC	22PF 10% 500V
C532	1-124-927-11	ELECT	4.7uF 20% 100V	C710	1-161-959-00	CERAMIC	22PF 10% 500V
C540	1-124-907-11	ELECT	10uF 20% 50V	C711	1-136-165-00	FILM	0.1uF 5% 50V
C551	1-162-282-31	CERAMIC	100PF 10% 50V	C712	1-136-165-00	FILM	0.1uF 5% 50V
C552	1-124-927-11	ELECT	4.7uF 20% 100V	C713	1-136-157-00	FILM	0.022uF 5% 50V (D715:US/D915:US, AUS)
C553	1-162-282-31	CERAMIC	100PF 10% 50V	C713	1-136-161-00	FILM	0.047uF 5% 50V (D715:CND/D915:CND)
C554	1-124-477-11	ELECT	47uF 20% 25V	C714	1-136-161-00	FILM	0.047uF 5% 50V (D715:CND/D915:CND)
C555	1-130-480-00	MYLAR	0.0056uF 5% 50V	C715	1-162-282-31	CERAMIC	100PF 10% 50V
C556	1-130-473-00	MYLAR	0.0015uF 5% 50V	C721	1-136-169-00	FILM	0.22uF 5% 50V
C557	1-124-903-11	ELECT	1uF 20% 50V	C722	1-124-471-00	ELECT	1000uF 20% 6.3V
C558	1-124-477-11	ELECT	47uF 20% 25V	C751	1-124-927-11	ELECT	4.7uF 20% 100V
C621	1-124-927-11	ELECT	4.7uF 20% 100V	C752	1-162-288-31	CERAMIC	330PF 10% 50V
C622	1-162-282-31	CERAMIC	100PF 10% 50V	C753	1-102-989-00	CERAMIC	68PF 5% 500V
C623	1-162-282-31	CERAMIC	100PF 10% 50V	C754	1-102-989-00	CERAMIC	68PF 5% 500V
C625	1-124-925-11	ELECT	2.2uF 20% 100V	C755	1-124-916-11	ELECT	22uF 20% 63V
C627	1-136-157-00	FILM	0.022uF 5% 50V	C756	1-124-443-00	ELECT	100uF 20% 10V
C628	1-164-159-11	CERAMIC	0.1uF 50V	C757	1-164-040-11	CERAMIC	4PF 0.25PF 50V
C629	1-124-927-11	ELECT	4.7uF 20% 100V	C758	1-124-477-11	ELECT	47uF 20% 25V
C651	1-124-927-11	ELECT	4.7uF 20% 100V	C759	1-161-959-00	CERAMIC	22PF 10% 500V
C652	1-162-288-31	CERAMIC	330PF 10% 50V	C760	1-161-959-00	CERAMIC	22PF 10% 500V
C653	1-102-989-00	CERAMIC	68PF 5% 500V	C761	1-136-165-00	FILM	0.1uF 5% 50V
C654	1-102-989-00	CERAMIC	68PF 5% 500V	C762	1-136-165-00	FILM	0.1uF 5% 50V
C655	1-124-916-11	ELECT	22uF 20% 63V	C763	1-136-157-00	FILM	0.022uF 5% 50V (D715:US/D915:US, AUS)
				C763	1-136-161-00	FILM	0.047uF 5% 50V (D715:CND/D915:CND)

MAIN

Ref. No.	Part No.	Description	Remark	Ref. No.	Part No.	Description	Remark
C764	1-136-161-00	FILM 0.047uF 5% 50V (D715:CND/D915:CND)		D703	8-719-815-85	DIODE 1S1585	
C971	1-109-932-11	ELECT 10000uF 20% 71V (D915:US, CND)		D704	8-719-815-85	DIODE 1S1585	
C971	1-125-729-11	ELECT 10000uF 20% 63V (D715/D915:AUS)		D705	8-719-987-63	DIODE 1N4148M	
C972	1-109-932-11	ELECT 10000uF 20% 71V (D915:US, CND)		D706	8-719-987-63	DIODE 1N4148M	
C972	1-125-729-11	ELECT 10000uF 20% 63V (D715/D915:AUS)		D753	8-719-815-85	DIODE 1S1585	
C973	1-164-097-11	CERAMIC 0.022uF 50V		D754	8-719-815-85	DIODE 1S1585	
C974	1-164-097-11	CERAMIC 0.022uF 50V		D910	8-719-987-63	DIODE 1N4148M	
C975	1-124-618-11	ELECT 2200uF 20% 35V		D911	8-719-987-63	DIODE 1N4148M	
C976	1-126-105-11	ELECT 1000uF 20% 35V		D971	8-719-302-38	DIODE RBV-602-01	
C977	1-124-618-11	ELECT 2200uF 20% 35V		D973	8-719-312-09	DIODE RBA-402	
C978	1-124-618-11	ELECT 2200uF 20% 35V		D974	8-719-002-76	DIODE UZL-36H	
C979	1-124-477-11	ELECT 47uF 20% 25V		D975	8-719-987-63	DIODE 1N4148M	
C980	1-124-477-11	ELECT 47uF 20% 25V		< IC >			
C981	1-124-472-11	ELECT 470uF 20% 10V		IC501	8-759-634-51	IC M5218AP	
C982	1-124-907-11	ELECT 10uF 20% 50V		IC502	8-759-805-14	IC LC7822	
C983	1-124-907-11	ELECT 10uF 20% 50V		IC503	8-759-805-14	IC LC7822	
C985	1-124-903-11	ELECT 1uF 20% 50V		IC601	8-749-010-16	IC STK350-130	
C988	1-102-394-11	CERAMIC 0.01uF 250V		IC621	8-759-502-33	IC SI-18752	
C989	1-102-394-11	CERAMIC 0.01uF 250V		IC701	8-749-920-70	IC STK3102-MK3	
< CONNECTOR >				IC971	8-759-263-43	IC TA78M12S	
CNJ502	1-691-887-11	JACK, PIN 6P (PHONO, CD, DAT/MD)		IC972	8-759-604-45	IC M5F79M12L	
CNJ503	1-580-825-11	JACK, PIN 6P (DAT/MD, TV, LD)		IC973	8-759-604-35	IC M5F78M05L	
CNJ504	1-580-825-11	JACK, PIN 6P (VIDEO1, VIDEO2)		< COIL >			
CNJ505	1-580-825-11	JACK, PIN 6P (VIDEO1, TAPE MONITOR)		L621	1-420-872-00	COIL, AIR CORE	
CNP301	1-691-161-11	PIN, CONNECTOR 4P		L651	1-420-872-00	COIL, AIR CORE	
CNP302	1-691-168-11	PIN, CONNECTOR 11P		L701	1-420-872-00	COIL, AIR CORE	
CNP303	1-691-165-11	PIN, CONNECTOR 8P		L751	1-420-872-00	COIL, AIR CORE	
* CNP701	1-564-509-11	PLUG, CONNECTOR 6P		< TRANSISTOR >			
CNP702	1-691-773-11	PLUG (MICRO CONNECTOR) 11P		Q531	8-729-141-30	TRANSISTOR 2SC3623A-LK	
CNP801	1-691-765-11	PLUG (MICRO CONNECTOR) 3P		Q532	8-729-900-36	TRANSISTOR DTC124ES	
CNP802	1-691-768-11	PLUG (MICRO CONNECTOR) 6P		Q581	8-729-141-30	TRANSISTOR 2SC3623A-LK	
CNS252	1-766-200-11	SOCKET, CONNECTOR PIN 5P (D915)		Q614	8-729-119-79	TRANSISTOR 2SC2785-FEK	
< FUSE >				Q643	8-729-119-79	TRANSISTOR 2SC2785-FEK	
△F973	1-532-748-11	FUSE, GLASS TUBE(6.3A/125V) (EXCEPT D915:AUS)		Q655	8-729-026-08	TRANSISTOR 2SC4495	
△F974	1-532-748-11	FUSE, GLASS TUBE(6.3A/125V) (EXCEPT D915:AUS)		Q658	8-729-022-16	TRANSISTOR 2SD2390-OPY-M (D715)	
< DIODE >				Q658	8-749-010-25	TRANSISTOR MN2488-OPY-M (D915)	
D540	8-719-987-63	DIODE 1N4148M		Q659	8-729-022-15	TRANSISTOR 2SB1560-OPY-M (D715)	
D641	8-719-987-63	DIODE 1N4148M		Q659	8-749-010-26	TRANSISTOR MP1620-OPY-M (D915)	
D645	8-719-987-63	DIODE 1N4148M		Q661	8-729-140-82	TRANSISTOR 2SA988-PAFAEA	
D652	8-719-815-85	DIODE 1S1585		Q662	8-729-140-82	TRANSISTOR 2SA988-PAFAEA	
D653	8-719-815-85	DIODE 1S1585		Q701	8-729-026-08	TRANSISTOR 2SC4495	
				Q705	8-729-022-16	TRANSISTOR 2SD2390-OPY-M (D715)	
				Q705	8-749-010-25	TRANSISTOR MN2488-OPY-M (D915)	
				Q706	8-729-022-15	TRANSISTOR 2SB1560-OPY-M (D715)	
				Q706	8-749-010-26	TRANSISTOR MP1620-OPY-M (D915)	
				Q707	8-729-140-82	TRANSISTOR 2SA988-PAFAEA	
				Q708	8-729-140-82	TRANSISTOR 2SA988-PAFAEA	
				Q719	8-729-119-79	TRANSISTOR 2SC2785-FEK	

The components identified by mark \triangle or dotted line with mark \triangle are critical for safety.
Replace only with part number specified.

Les composants identifiés par une marque \triangle sont critiques pour la sécurité.
Ne les remplacer que par une pièce portant le numéro spécifié.

Ref. No.	Part No.	Description	Remark	Ref. No.	Part No.	Description	Remark
Q721	8-729-140-84	TRANSISTOR	2SC1841-PAFAEA	R562	1-249-417-11	CARBON	1K 5% 1/4W F
Q722	8-729-119-79	TRANSISTOR	2SC2785-FEK	R563	1-249-417-11	CARBON	1K 5% 1/4W F
Q723	8-729-119-79	TRANSISTOR	2SC2785-FEK	R564	1-249-417-11	CARBON	1K 5% 1/4W F
Q751	8-729-026-08	TRANSISTOR	2SC4495	R565	1-249-417-11	CARBON	1K 5% 1/4W F
Q755	8-729-022-16	TRANSISTOR	2SD2390-OPY-M (D715)	R566	1-249-417-11	CARBON	1K 5% 1/4W F
Q755	8-749-010-25	TRANSISTOR	MN2488-OPY-M (D915)	R567	1-249-417-11	CARBON	1K 5% 1/4W F
Q756	8-729-022-15	TRANSISTOR	2SB1560-OPY-M (D715)	R568	1-249-417-11	CARBON	1K 5% 1/4W F
Q756	8-749-010-26	TRANSISTOR	MP1620-OPY-M (D915)	R569	1-249-417-11	CARBON	1K 5% 1/4W F
Q757	8-729-140-82	TRANSISTOR	2SA988-PAFAEA	R570	1-249-429-11	CARBON	10K 5% 1/4W
Q758	8-729-140-82	TRANSISTOR	2SA988-PAFAEA	R582	1-247-807-31	CARBON	100 5% 1/4W
Q971	8-729-140-96	TRANSISTOR	2SD774-34	R595	1-249-437-11	CARBON	47K 5% 1/4W
Q972	8-729-119-79	TRANSISTOR	2SC2785-FEK	R621	1-249-417-11	CARBON	1K 5% 1/4W F
< RESISTOR >				R622	1-249-439-11	CARBON	68K 5% 1/4W
R501	1-249-411-11	CARBON	330 5% 1/4W	R623	1-249-417-11	CARBON	1K 5% 1/4W F
R502	1-249-441-11	CARBON	100K 5% 1/4W	R624	1-249-439-11	CARBON	68K 5% 1/4W
R503	1-249-441-11	CARBON	100K 5% 1/4W	R628	1-249-389-11	CARBON	4.7 5% 1/4W F
R504	1-249-416-11	CARBON	820 5% 1/4W F	△R629	1-249-393-11	CARBON	10 5% 1/4W F
R505	1-247-897-11	CARBON	560K 5% 1/4W	R630	1-249-429-11	CARBON	10K 5% 1/4W
R506	1-249-437-11	CARBON	47K 5% 1/4W	R641	1-249-421-11	CARBON	2.2K 5% 1/4W F
R507	1-249-441-11	CARBON	100K 5% 1/4W	R643	1-249-421-11	CARBON	2.2K 5% 1/4W F
R508	1-249-409-11	CARBON	220 5% 1/4W F	R651	1-249-417-11	CARBON	1K 5% 1/4W F
R509	1-249-421-11	CARBON	2.2K 5% 1/4W F	R652	1-249-438-11	CARBON	56K 5% 1/4W
R510	1-249-417-11	CARBON	1K 5% 1/4W F	R653	1-249-413-11	CARBON	470 5% 1/4W F
R511	1-249-417-11	CARBON	1K 5% 1/4W F	△R654	1-249-401-11	CARBON	47 5% 1/4W F
R512	1-249-417-11	CARBON	1K 5% 1/4W F	△R655	1-249-401-11	CARBON	47 5% 1/4W F
R513	1-249-417-11	CARBON	1K 5% 1/4W F	R661	1-249-438-11	CARBON	56K 5% 1/4W
R514	1-249-417-11	CARBON	1K 5% 1/4W F	R662	1-249-414-11	CARBON	560 5% 1/4W F
R515	1-249-417-11	CARBON	1K 5% 1/4W F	R663	1-249-417-11	CARBON	1K 5% 1/4W F
R516	1-249-417-11	CARBON	1K 5% 1/4W F	△R664	1-249-393-11	CARBON	10 5% 1/4W F
R517	1-249-417-11	CARBON	1K 5% 1/4W F	R667	1-249-411-11	CARBON	330 5% 1/4W
R518	1-249-417-11	CARBON	1K 5% 1/4W F	△R668	1-249-393-11	CARBON	10 5% 1/4W F
R519	1-249-417-11	CARBON	1K 5% 1/4W F	R669	1-249-424-11	CARBON	3.9K 5% 1/4W F
R520	1-249-429-11	CARBON	10K 5% 1/4W	R670	1-249-424-11	CARBON	3.9K 5% 1/4W F
R530	1-249-425-11	CARBON	4.7K 5% 1/4W F	R671	1-249-425-11	CARBON	4.7K 5% 1/4W F
R532	1-247-807-31	CARBON	100 5% 1/4W	△R672	1-239-912-21	ENCAPSULATED COMPONENT	0.22 2W
R533	1-249-421-11	CARBON	2.2K 5% 1/4W F	R674	1-249-425-11	CARBON	4.7K 5% 1/4W F
R540	1-249-429-11	CARBON	10K 5% 1/4W	R675	1-249-431-11	CARBON	15K 5% 1/4W
R545	1-249-437-11	CARBON	47K 5% 1/4W	R676	1-249-431-11	CARBON	15K 5% 1/4W
R551	1-249-411-11	CARBON	330 5% 1/4W	R677	1-260-072-11	CARBON	4.7 5% 1/2W
R552	1-249-441-11	CARBON	100K 5% 1/4W	R678	1-249-433-11	CARBON	22K 5% 1/4W
R553	1-249-441-11	CARBON	100K 5% 1/4W	R679	1-260-076-11	CARBON	10 5% 1/2W
R554	1-249-416-11	CARBON	820 5% 1/4W F	R701	1-249-417-11	CARBON	1K 5% 1/4W F
R555	1-247-897-11	CARBON	560K 5% 1/4W	R702	1-249-438-11	CARBON	56K 5% 1/4W
R556	1-249-437-11	CARBON	47K 5% 1/4W	R703	1-249-413-11	CARBON	470 5% 1/4W F
R557	1-249-441-11	CARBON	100K 5% 1/4W	△R704	1-249-397-11	CARBON	22 5% 1/4W F
R558	1-249-409-11	CARBON	220 5% 1/4W F	R705	1-249-413-11	CARBON	470 5% 1/4W F
R559	1-249-421-11	CARBON	2.2K 5% 1/4W F	R706	1-249-438-11	CARBON	56K 5% 1/4W
R560	1-249-417-11	CARBON	1K 5% 1/4W F	R707	1-249-417-11	CARBON	1K 5% 1/4W F
R561	1-249-417-11	CARBON	1K 5% 1/4W F	R708	1-249-411-11	CARBON	330 5% 1/4W
				△R709	1-249-393-11	CARBON	10 5% 1/4W F

<p>The components identified by mark △ or dotted line with mark △ are critical for safety. Replace only with part number specified.</p>	<p>Les composants identifiés par une marque △ sont critiques pour la sécurité. Ne les remplacer que par une pièce portant le numéro spécifié.</p>
---	---

MAIN

MAIN VOLUME

MUTING

POWER SUPPLY

Ref. No.	Part No.	Description	Remark
△R710	1-249-393-11	CARBON	10 5% 1/4W F
R711	1-249-424-11	CARBON	3.9K 5% 1/4W F
R712	1-249-424-11	CARBON	3.9K 5% 1/4W F
△R715	1-239-912-21	ENCAPSULATED COMPONENT	0.22 2W
R717	1-249-425-11	CARBON	4.7K 5% 1/4W F
R718	1-249-431-11	CARBON	15K 5% 1/4W
R719	1-249-425-11	CARBON	4.7K 5% 1/4W F
R720	1-249-431-11	CARBON	15K 5% 1/4W
R721	1-260-072-11	CARBON	4.7 5% 1/2W
R722	1-260-076-11	CARBON	10 5% 1/2W
R725	1-249-417-11	CARBON	1K 5% 1/4W F
R726	1-249-429-11	CARBON	10K 5% 1/4W
R727	1-249-439-11	CARBON	68K 5% 1/4W
R728	1-249-436-11	CARBON	39K 5% 1/4W
R729	1-249-434-11	CARBON	27K 5% 1/4W
R730	1-249-433-11	CARBON	22K 5% 1/4W
R731	1-249-437-11	CARBON	47K 5% 1/4W
R751	1-249-417-11	CARBON	1K 5% 1/4W F
R752	1-249-438-11	CARBON	56K 5% 1/4W
R753	1-249-413-11	CARBON	470 5% 1/4W F
△R754	1-249-397-11	CARBON	22 5% 1/4W F
R755	1-249-413-11	CARBON	470 5% 1/4W F
R756	1-249-438-11	CARBON	56K 5% 1/4W
R757	1-249-417-11	CARBON	1K 5% 1/4W F
R758	1-249-411-11	CARBON	330 5% 1/4W
△R759	1-249-393-11	CARBON	10 5% 1/4W F
△R760	1-249-393-11	CARBON	10 5% 1/4W F
R761	1-249-424-11	CARBON	3.9K 5% 1/4W F
R762	1-249-424-11	CARBON	3.9K 5% 1/4W F
△R765	1-239-912-21	ENCAPSULATED COMPONENT	0.22 2W
R767	1-249-425-11	CARBON	4.7K 5% 1/4W F
R768	1-249-431-11	CARBON	15K 5% 1/4W
R769	1-249-425-11	CARBON	4.7K 5% 1/4W F
R770	1-249-431-11	CARBON	15K 5% 1/4W
R771	1-260-072-11	CARBON	4.7 5% 1/2W
R772	1-260-076-11	CARBON	10 5% 1/2W
△R971	1-215-906-11	METAL OXIDE	15 5% 3W F
△R972	1-215-909-11	METAL OXIDE	47 5% 3W F
△R973	1-215-909-11	METAL OXIDE	47 5% 3W F
△R975	1-249-409-11	CARBON	220 5% 1/4W F
R976	1-249-426-11	CARBON	5.6K 5% 1/4W
R977	1-249-421-11	CARBON	2.2K 5% 1/4W F
< RELAY >			
RY541	1-515-614-11	RELAY	
RY641	1-515-533-11	RELAY	
RY643	1-515-765-11	RELAY	
RY701	1-515-765-11	RELAY	
RY902	1-515-894-11	RELAY (D715:US/D915:US, AUS)	
RY903	1-515-918-11	RELAY (D715:CND/D915:CND)	

Ref. No.	Part No.	Description	Remark
RY904	1-515-918-11	RELAY (D715:CND/D915:CND)	

*	1-652-305-11	MAIN VOLUME BOARD	

< CAPACITOR >			
C598	1-124-903-11	ELECT	1uF 20% 50V
C599	1-124-903-11	ELECT	1uF 20% 50V
< CONNECTOR >			
* CNP510	1-564-521-11	PLUG, CONNECTOR 6P	
CNS511	1-766-201-11	SOCKET, CONNECTOR PIN 11P	
< RESISTOR >			
R599	1-249-409-11	CARBON	220 5% 1/4W F
< VARIABLE RESISTOR >			
RV503	1-241-816-11	RES, VAR, CARBON 100KX4 (MASTER VOLUME)	

*	1-652-297-11	MUTING BOARD	

< CONNECTOR >			
* CNP101	1-569-798-11	PLUG, CONNECTOR 6P	
< DIODE >			
D109	8-719-301-49	LED	SEL2810A (MUTING -20dB)
D110	8-719-301-49	LED	SEL2810A (LOW BOOST)
< RESISTOR >			
R147	1-249-410-11	CARBON	270 5% 1/4W F
R148	1-249-410-11	CARBON	270 5% 1/4W F
< SWITCH >			
S113	1-554-303-21	SWITCH, TACTILE (MUTING -20dB)	
S120	1-554-303-21	SWITCH, TACTILE (LOW BOOST)	

*	A-4369-957-A	POWER SUPPLY BOARD, COMPLETE	

(EXCEPT D915:AUS)			
*	A-4369-966-A	POWER SUPPLY BOARD, COMPLETE (D915:AUS)	

	1-533-293-11	FUSE HOLDER	
*	4-942-204-01	PLATE, GROUND	

The components identified by mark Δ or dotted line with mark Δ are critical for safety. Replace only with part number specified.	Les composants identifiés par une marque Δ sont critiques pour la sécurité. Ne les remplacer que par une pièce portant le numéro spécifié.
--	---

POWER SUPPLY **PT1** **PT2**

Ref. No.	Part No.	Description	Remark
	7-682-548-04	SCREW +BVTT 3X8 (S)	
		< BASE POST >	
* BP903	1-535-139-00	BASE POST 19MM (10MM PITCH) 2P	
		< CAPACITOR >	
C951	1-164-097-11	CERAMIC 0.022uF	50V
C952	1-164-097-11	CERAMIC 0.022uF	50V
C953	1-124-557-11	ELECT 1000uF 20%	25V
C954	1-162-282-31	CERAMIC 100PF 10%	50V
C955	1-124-477-11	ELECT 47uF 20%	25V
C956	1-124-477-11	ELECT 47uF 20%	25V
C957	1-124-903-11	ELECT 1uF 20%	50V
C958	1-164-097-11	CERAMIC 0.022uF	50V
C959	1-124-464-11	ELECT 0.22uF 20%	50V
C960	1-161-494-00	CERAMIC 0.022uF	25V
		< CONNECTOR >	
△CNJ901	1-540-060-11	OUTLET, AC (POLAR) (AC OUTLET) (EXCEPT D915:AUS)	
	CNP901	1-564-321-00	PIN, CONNECTOR 2P
* CNP903	1-565-495-11	CONNECTOR, BOARD TO BOARD 4P	
	CNP912	1-564-321-00	PIN, CONNECTOR 2P (D915:AUS)
		< DIODE >	
D951	8-719-024-99	DIODE 11ES2	
D952	8-719-024-99	DIODE 11ES2	
D953	8-719-024-99	DIODE 11ES2	
D954	8-719-024-99	DIODE 11ES2	
D955	8-719-987-63	DIODE 1N4148M	
D956	8-719-987-63	DIODE 1N4148M	
D957	8-719-933-41	DIODE HZS6C3L	
D958	8-719-987-63	DIODE 1N4148M	
D959	8-719-933-41	DIODE HZS6C3L	
D960	8-719-985-53	DIODE HZS4ALL	
		< FUSE >	
△F902	1-532-237-00	FUSE, TIME LAG (T3. 15A/250V) (D915:AUS)	
△F902	1-532-748-11	FUSE, GLASS TUBE (6. 3A/125V) (EXCEPT D915:AUS)	
△F903	1-532-286-00	FUSE (T2. 5A/250V) (D915:AUS)	
		< TRANSISTOR >	
Q951	8-729-209-15	TRANSISTOR 2SD2012	
Q952	8-729-119-79	TRANSISTOR 2SC2785-FEK	
Q953	8-729-119-79	TRANSISTOR 2SC2785-FEK	
Q954	8-729-119-76	TRANSISTOR 2SA1175-HFE	
Q955	8-729-119-76	TRANSISTOR 2SA1175-HFE	
Q956	8-729-119-79	TRANSISTOR 2SC2785-FEK	

Ref. No.	Part No.	Description	Remark
		< RESISTOR >	
△R901	1-202-725-00	SOLID 3.3M 10% 1/2W (EXCEPT D915:AUS)	
R951	1-249-396-11	CARBON 18 5% 1/4W F	
R952	1-249-417-11	CARBON 1K 5% 1/4W F	
R953	1-249-437-11	CARBON 47K 5% 1/4W	
R954	1-249-425-11	CARBON 4.7K 5% 1/4W F	
R955	1-249-433-11	CARBON 22K 5% 1/4W	
R956	1-249-429-11	CARBON 10K 5% 1/4W	
R957	1-249-417-11	CARBON 1K 5% 1/4W F	
R958	1-249-429-11	CARBON 10K 5% 1/4W	
R959	1-249-429-11	CARBON 10K 5% 1/4W	
R960	1-249-426-11	CARBON 5.6K 5% 1/4W	
R961	1-249-417-11	CARBON 1K 5% 1/4W F	
R962	1-249-426-11	CARBON 5.6K 5% 1/4W	
		< RELAY >	
△RY901	1-515-701-11	RELAY (EXCEPT D915:AUS)	
△RY901	1-515-701-21	RELAY (D915:AUS)	
		< TRANSFORMER >	
△T901	1-450-358-11	TRANSFORMER, POWER (D915:AUS)	
△T901	1-450-361-11	TRANSFORMER, POWER (EXCEPT D915:AUS)	

*	1-652-303-11	PT1 BOARD *****	

*	1-652-299-11	PT2 BOARD (EXCEPT D915:AUS) *****	
*	1-652-300-11	PT2 BOARD (D915:AUS) *****	
		< CONNECTOR >	
	CNP806	1-691-771-11	PLUG (MICRO CONNECTOR) 9P
		< FUSE >	
△F971	1-532-237-00	FUSE, TIME LAG (T3. 15A/250V) (D915:AUS)	
△F971	1-576-107-11	FUSE (3. 15A/250V) (EXCEPT D915:AUS)	
△F972	1-532-237-00	FUSE, TIME LAG (T3. 15A/250V) (D915:AUS)	
△F972	1-576-107-11	FUSE (3. 15A/250V) (EXCEPT D915:AUS)	

<p>The components identified by mark △ or dotted line with mark △ are critical for safety. Replace only with part number specified.</p>	<p>Les composants identifiés par une marque △ sont critiques pour la sécurité. Ne les remplacer que par une pièce portant le numéro spécifié.</p>
---	---

SPEAKER TERMINAL SURROUND

Ref.No.	Part No.	Description	Remark	Ref.No.	Part No.	Description	Remark
*	1-652-308-11	SPEAKER TERMINAL BOARD *****		C325	1-136-165-00	FILM 0.1uF 5% 50V	
		< CONNECTOR >		C326	1-136-165-00	FILM 0.1uF 5% 50V	
* CNP703	1-564-518-11	PLUG, CONNECTOR 3P		C327	1-124-902-00	ELECT 0.47uF 20% 50V	
CNP704	1-691-773-11	PLUG (MICRO CONNECTOR) 11P		C328	1-124-927-11	ELECT 4.7uF 20% 100V	
		< RESISTOR >		C329	1-124-902-00	ELECT 0.47uF 20% 50V	
△R723	1-216-431-11	METAL OXIDE 560 5% 1W F		C330	1-124-927-11	ELECT 4.7uF 20% 100V	
△R773	1-216-431-11	METAL OXIDE 560 5% 1W F		C331	1-124-250-00	ELECT 0.15uF 20% 50V	
		< SWITCH >		C332	1-126-962-11	ELECT 3.3uF 20% 50V	
S701	1-572-322-11	SWITCH, SLIDE (SPEAKERS)		C333	1-124-250-00	ELECT 0.15uF 20% 50V	
S710	1-692-196-11	SWITCH, SLIDE (IMPEDANCE SELECTOR) (D915)		C334	1-136-157-00	FILM 0.022uF 5% 50V	
		< TERMINAL >		C335	1-130-479-00	MYLAR 0.0047uF 5% 50V	
TM701	1-537-376-11	TERMINAL BOARD (SP) (FRONT SPEAKERS)		C336	1-124-120-11	ELECT 220uF 20% 25V	
TM702	1-537-510-11	TERMINAL BOARD (SPEAKER) (6P) (SURROUND SPEAKERS)		C337	1-124-907-11	ELECT 10uF 20% 50V	
		*****		C338	1-124-907-11	ELECT 10uF 20% 50V	
*	A-4369-951-A	SURROUND BOARD, COMPLETE *****		C339	1-124-907-11	ELECT 10uF 20% 50V	
		< CAPACITOR >		C340	1-124-907-11	ELECT 10uF 20% 50V	
C201	1-161-379-00	CERAMIC 0.01uF 20% 25V		C341	1-124-120-11	ELECT 220uF 20% 25V	
C202	1-124-477-11	ELECT 47uF 20% 25V		C342	1-126-962-11	ELECT 3.3uF 20% 50V	
C203	1-161-379-00	CERAMIC 0.01uF 20% 25V		C343	1-126-962-11	ELECT 3.3uF 20% 50V	
C204	1-124-903-11	ELECT 1uF 20% 50V		C344	1-136-165-00	FILM 0.1uF 5% 50V	
C206	1-104-905-11	DOUBLE LAYERS 0.22F 5.5V		C345	1-136-165-00	FILM 0.1uF 5% 50V	
C207	1-161-379-00	CERAMIC 0.01uF 20% 25V		C346	1-124-902-00	ELECT 0.47uF 20% 50V	
C208	1-124-925-11	ELECT 2.2uF 20% 100V		C347	1-124-927-11	ELECT 4.7uF 20% 100V	
C209	1-161-379-00	CERAMIC 0.01uF 20% 25V		C348	1-124-902-00	ELECT 0.47uF 20% 50V	
C301	1-124-119-00	ELECT 330uF 20% 16V		C349	1-124-927-11	ELECT 4.7uF 20% 100V	
C302	1-124-120-11	ELECT 220uF 20% 25V		C350	1-124-250-00	ELECT 0.15uF 20% 50V	
C303	1-136-159-00	FILM 0.033uF 5% 50V		C351	1-126-962-11	ELECT 3.3uF 20% 50V	
C304	1-130-473-00	MYLAR 0.0015uF 5% 50V		C352	1-124-250-00	ELECT 0.15uF 20% 50V	
C305	1-136-159-00	FILM 0.033uF 5% 50V		C353	1-164-159-11	CERAMIC 0.1uF 50V	
C306	1-124-903-11	ELECT 1uF 20% 50V		C354	1-164-159-11	CERAMIC 0.1uF 50V	
C307	1-124-907-11	ELECT 10uF 20% 50V		C355	1-164-159-11	CERAMIC 0.1uF 50V	
C308	1-124-907-11	ELECT 10uF 20% 50V		C356	1-164-159-11	CERAMIC 0.1uF 50V	
C310	1-124-927-11	ELECT 4.7uF 20% 100V		C358	1-161-379-00	CERAMIC 0.01uF 20% 25V	
C311	1-124-925-11	ELECT 2.2uF 20% 100V		C359	1-124-927-11	ELECT 4.7uF 20% 100V	
C313	1-164-159-11	CERAMIC 0.1uF 50V		C360	1-124-927-11	ELECT 4.7uF 20% 100V	
C315	1-136-159-00	FILM 0.033uF 5% 50V		C401	1-164-159-11	CERAMIC 0.1uF 50V	
C316	1-124-907-11	ELECT 10uF 20% 50V		C404	1-136-171-00	FILM 0.33uF 5% 50V	
C318	1-130-469-00	MYLAR 680PF 5% 50V		C405	1-136-159-00	FILM 0.033uF 5% 50V	
C322	1-124-927-11	ELECT 4.7uF 20% 100V		C406	1-124-927-11	ELECT 4.7uF 20% 100V	
C323	1-136-173-00	FILM 0.47uF 5% 50V		C407	1-162-209-31	CERAMIC 27PF 5% 50V	
C324	1-124-910-11	ELECT 47uF 20% 50V		C408	1-124-477-11	ELECT 47uF 20% 25V	
				C409	1-164-159-11	CERAMIC 0.1uF 50V	
				C410	1-124-477-11	ELECT 47uF 20% 25V	
				C411	1-136-154-00	FILM 0.012uF 5% 50V	
				C412	1-136-163-00	FILM 0.068uF 5% 50V	
				C413	1-130-476-00	MYLAR 0.0027uF 5% 50V	
				C414	1-124-907-11	ELECT 10uF 20% 50V	
				C415	1-136-157-00	FILM 0.022uF 5% 50V	
				C416	1-124-927-11	ELECT 4.7uF 20% 100V	
				C454	1-136-171-00	FILM 0.33uF 5% 50V	

The components identified by mark \triangle or dotted line with mark \triangle are critical for safety. Replace only with part number specified.	Les composants identifiés par une marque \triangle sont critiques pour la sécurité. Ne les remplacer que par une pièce portant le numéro spécifié.
---	---

SURROUND

Ref. No.	Part No.	Description	Remark	Ref. No.	Part No.	Description	Remark
C455	1-136-159-00	FILM	0.033uF 5% 50V	Q210	8-729-900-63	TRANSISTOR DTA124ES	
C456	1-124-927-11	ELECT	4.7uF 20% 100V	Q211	8-729-900-63	TRANSISTOR DTA124ES	
C457	1-162-209-31	CERAMIC	27PF 5% 50V	Q212	8-729-900-63	TRANSISTOR DTA124ES	
C458	1-124-477-11	ELECT	47uF 20% 25V	Q213	8-729-900-63	TRANSISTOR DTA124ES	
C459	1-164-159-11	CERAMIC	0.1uF 50V	Q305	8-729-141-30	TRANSISTOR 2SC3623A-LK	
C460	1-124-477-11	ELECT	47uF 20% 25V	Q306	8-729-141-30	TRANSISTOR 2SC3623A-LK	
C461	1-136-154-00	FILM	0.012uF 5% 50V	Q307	8-729-141-30	TRANSISTOR 2SC3623A-LK	
C462	1-136-163-00	FILM	0.068uF 5% 50V	Q308	8-729-141-30	TRANSISTOR 2SC3623A-LK	
C463	1-130-476-00	MYLAR	0.0027uF 5% 50V	Q401	8-729-202-67	TRANSISTOR 2SK246-GR3	
C464	1-124-907-11	ELECT	10uF 20% 50V	Q402	8-729-141-30	TRANSISTOR 2SC3623A-LK	
C465	1-136-157-00	FILM	0.022uF 5% 50V	Q403	8-729-141-30	TRANSISTOR 2SC3623A-LK	
C822	1-124-477-11	ELECT	47uF 20% 25V	Q404	8-729-141-30	TRANSISTOR 2SC3623A-LK	
< FILTER >				Q451	8-729-202-67	TRANSISTOR 2SK246-GR3	
CF201	1-567-776-41	VIBRATOR, CERAMIC (6MHz)		Q452	8-729-141-30	TRANSISTOR 2SC3623A-LK	
< CONNECTOR >				Q453	8-729-141-30	TRANSISTOR 2SC3623A-LK	
CNP210	1-766-205-11	PLUG, CONNECTOR PIN 14P		Q454	8-729-141-30	TRANSISTOR 2SC3623A-LK	
CNP501	1-766-204-11	PLUG, CONNECTOR PIN 11P		Q808	8-729-180-92	TRANSISTOR 2SD809-K	
CNS102	1-568-838-11	SOCKET, CONNECTOR 21P		< RESISTOR >			
* CNS310	1-691-174-11	CONNECTOR (BOARD TO BOARD) 4P		R201	1-249-437-11	CARBON 47K 5% 1/4W	
CNS311	1-691-181-11	CONNECTOR (BOARD TO BOARD) 11P		R202	1-249-437-11	CARBON 47K 5% 1/4W	
CNS312	1-691-178-11	CONNECTOR (BOARD TO BOARD) 8P		R203	1-247-807-31	CARBON 100 5% 1/4W	
< DIODE >				R204	1-249-429-11	CARBON 10K 5% 1/4W	
D201	8-719-987-63	DIODE 1N4148M		R205	1-249-429-11	CARBON 10K 5% 1/4W	
D202	8-719-987-63	DIODE 1N4148M		R206	1-249-429-11	CARBON 10K 5% 1/4W	
D204	8-719-987-63	DIODE 1N4148M		R207	1-249-429-11	CARBON 10K 5% 1/4W	
D205	8-719-987-63	DIODE 1N4148M		R208	1-249-429-11	CARBON 10K 5% 1/4W	
D542	8-719-987-63	DIODE 1N4148M		R209	1-249-425-11	CARBON 4.7K 5% 1/4W F	
D817	8-719-001-30	DIODE UZL-9H3		R210	1-249-437-11	CARBON 47K 5% 1/4W	
< IC >				R211	1-249-421-11	CARBON 2.2K 5% 1/4W F	
IC201	8-759-820-62	IC LB1639		R212	1-249-437-11	CARBON 47K 5% 1/4W	
IC202	8-759-264-78	IC uPD75518GF-195-3B9		R213	1-249-423-11	CARBON 3.3K 5% 1/4W F	
IC300	8-759-168-98	IC LV1010N		R214	1-249-433-11	CARBON 22K 5% 1/4W	
IC301	8-759-248-74	IC LA2785		R215	1-249-425-11	CARBON 4.7K 5% 1/4W F	
IC302	8-759-634-51	IC M5218AP		R216	1-249-429-11	CARBON 10K 5% 1/4W	
IC401	8-759-072-32	IC TC9184P		R217	1-249-429-11	CARBON 10K 5% 1/4W	
IC412	8-759-634-51	IC M5218AP		R218	1-249-429-11	CARBON 10K 5% 1/4W	
< COIL >				R219	1-249-429-11	CARBON 10K 5% 1/4W	
L201	1-410-521-11	INDUCTOR 100uH		R220	1-249-429-11	CARBON 10K 5% 1/4W	
L301	1-410-521-11	INDUCTOR 100uH		R221	1-249-429-11	CARBON 10K 5% 1/4W	
L302	1-410-521-11	INDUCTOR 100uH		R222	1-249-429-11	CARBON 10K 5% 1/4W	
< TRANSISTOR >				R223	1-249-425-11	CARBON 4.7K 5% 1/4W F	
Q201	8-729-900-63	TRANSISTOR DTA124ES		R224	1-249-425-11	CARBON 4.7K 5% 1/4W F	
Q202	8-729-119-79	TRANSISTOR 2SC2785-FEK		R230	1-249-421-11	CARBON 2.2K 5% 1/4W F	
				R231	1-249-421-11	CARBON 2.2K 5% 1/4W F	
				R232	1-249-421-11	CARBON 2.2K 5% 1/4W F	
				R233	1-249-421-11	CARBON 2.2K 5% 1/4W F	
				R234	1-249-417-11	CARBON 1K 5% 1/4W F	
				R235	1-249-417-11	CARBON 1K 5% 1/4W F	
				R236	1-249-413-11	CARBON 470 5% 1/4W F	

SURROUND

TUNER VIDEO

Ref. No.	Part No.	Description	Remark
R237	1-249-413-11	CARBON	470 5% 1/4W F
R238	1-249-413-11	CARBON	470 5% 1/4W F
R239	1-249-413-11	CARBON	470 5% 1/4W F
R240	1-249-413-11	CARBON	470 5% 1/4W F
R241	1-249-413-11	CARBON	470 5% 1/4W F
R242	1-249-413-11	CARBON	470 5% 1/4W F
R243	1-249-413-11	CARBON	470 5% 1/4W F
R244	1-249-437-11	CARBON	47K 5% 1/4W
R245	1-249-437-11	CARBON	47K 5% 1/4W
R246	1-249-437-11	CARBON	47K 5% 1/4W
R247	1-249-437-11	CARBON	47K 5% 1/4W
R300	1-247-903-00	CARBON	1M 5% 1/4W
R301	1-249-411-11	CARBON	330 5% 1/4W
R302	1-249-431-11	CARBON	15K 5% 1/4W
R306	1-249-433-11	CARBON	22K 5% 1/4W
R307	1-249-436-11	CARBON	39K 5% 1/4W
R308	1-249-417-11	CARBON	1K 5% 1/4W F
R353	1-249-425-11	CARBON	4.7K 5% 1/4W F
R354	1-249-425-11	CARBON	4.7K 5% 1/4W F
R355	1-249-425-11	CARBON	4.7K 5% 1/4W F
R356	1-249-425-11	CARBON	4.7K 5% 1/4W F
R357	1-249-441-11	CARBON	100K 5% 1/4W
R358	1-249-441-11	CARBON	100K 5% 1/4W
R359	1-249-433-11	CARBON	22K 5% 1/4W
R360	1-249-430-11	CARBON	12K 5% 1/4W
R361	1-249-433-11	CARBON	22K 5% 1/4W
R362	1-249-433-11	CARBON	22K 5% 1/4W
R364	1-249-413-11	CARBON	470 5% 1/4W F
R365	1-249-413-11	CARBON	470 5% 1/4W F
R404	1-249-441-11	CARBON	100K 5% 1/4W
R405	1-249-423-11	CARBON	3.3K 5% 1/4W F
R406	1-247-883-00	CARBON	150K 5% 1/4W
R407	1-249-412-11	CARBON	390 5% 1/4W F
R408	1-249-427-11	CARBON	6.8K 5% 1/4W F
R409	1-249-427-11	CARBON	6.8K 5% 1/4W F
R410	1-249-440-11	CARBON	82K 5% 1/4W
R411	1-247-895-00	CARBON	470K 5% 1/4W
R412	1-249-419-11	CARBON	1.5K 5% 1/4W F
R413	1-249-425-11	CARBON	4.7K 5% 1/4W F
R414	1-247-897-11	CARBON	560K 5% 1/4W
R415	1-249-436-11	CARBON	39K 5% 1/4W
R416	1-249-434-11	CARBON	27K 5% 1/4W
R417	1-249-426-11	CARBON	5.6K 5% 1/4W
R418	1-249-418-11	CARBON	1.2K 5% 1/4W F
R419	1-249-417-11	CARBON	1K 5% 1/4W F
R420	1-247-807-31	CARBON	100 5% 1/4W
R421	1-249-417-11	CARBON	1K 5% 1/4W F
R422	1-249-417-11	CARBON	1K 5% 1/4W F
R426	1-249-425-11	CARBON	4.7K 5% 1/4W F
R427	1-249-441-11	CARBON	100K 5% 1/4W

Ref. No.	Part No.	Description	Remark
R428	1-249-435-11	CARBON	33K 5% 1/4W
R451	1-247-903-00	CARBON	1M 5% 1/4W
R454	1-249-441-11	CARBON	100K 5% 1/4W
R455	1-249-423-11	CARBON	3.3K 5% 1/4W F
R456	1-247-883-00	CARBON	150K 5% 1/4W
R457	1-249-412-11	CARBON	390 5% 1/4W F
R458	1-249-427-11	CARBON	6.8K 5% 1/4W F
R459	1-249-427-11	CARBON	6.8K 5% 1/4W F
R460	1-249-440-11	CARBON	82K 5% 1/4W
R461	1-247-895-00	CARBON	470K 5% 1/4W
R462	1-249-419-11	CARBON	1.5K 5% 1/4W F
R463	1-249-425-11	CARBON	4.7K 5% 1/4W F
R464	1-247-897-11	CARBON	560K 5% 1/4W
R465	1-249-436-11	CARBON	39K 5% 1/4W
R466	1-249-434-11	CARBON	27K 5% 1/4W
R467	1-249-426-11	CARBON	5.6K 5% 1/4W
R468	1-249-418-11	CARBON	1.2K 5% 1/4W F
R469	1-249-417-11	CARBON	1K 5% 1/4W F
R470	1-247-807-31	CARBON	100 5% 1/4W
R476	1-249-425-11	CARBON	4.7K 5% 1/4W F
R477	1-249-441-11	CARBON	100K 5% 1/4W
R478	1-249-435-11	CARBON	33K 5% 1/4W
R822	1-247-811-31	CARBON	150 5% 1/4W
< VIBRATOR >			
X301	1-579-952-21	VIBRATOR, CERAMIC (8MHz)	

*	1-652-302-11	TUNER VIDEO BOARD	

< CAPACITOR >			
C251	1-124-472-11	ELECT	470uF 20% 10V
C252	1-124-927-11	ELECT	4.7uF 20% 100V
C253	1-124-472-11	ELECT	470uF 20% 10V
C254	1-124-927-11	ELECT	4.7uF 20% 100V
C255	1-124-472-11	ELECT	470uF 20% 10V
C256	1-124-927-11	ELECT	4.7uF 20% 100V
C257	1-124-927-11	ELECT	4.7uF 20% 100V
C258	1-124-927-11	ELECT	4.7uF 20% 100V
C259	1-124-927-11	ELECT	4.7uF 20% 100V
< CONNECTOR >			
CNJ201	1-695-317-21	JACK, PIN 2P (TV/LD VIDEO IN)	
CNJ202	1-695-317-21	JACK, PIN 2P (VIDEO2 VIDEO IN/OUT)	
CNJ203	1-766-199-11	JACK, PIN 3P (VIDEO1 VIDEO IN/OUT, MONITOR VIDEO OUT)	
CNS251	1-766-202-11	SOCKET, CONNECTOR PIN 14P	

TUNER VIDEO

Ref. No.	Part No.	Description	Remark	Ref. No.	Part No.	Description	Remark
		< FRONT-END >				MISCELLANEOUS *****	
FE1	1-239-611-11	ENCAPSULATED COMPONENT (D915:AUS)		11	1-765-290-11	WIRE (FLAT TYPE) (21 CORE)	
FE1	1-239-727-11	ENCAPSULATED COMPONENT (FCC) (EXCEPT D915:AUS)		53	1-572-291-41	SWITCH, ROTARY SLIDE	
		< IC >		△70	1-690-609-11	CORD, POWER (EXCEPT D915:AUS)	
IC251	8-759-061-95	IC SN761200N		△71	1-696-848-21	CORD, POWER (D915:AUS)	
		< COIL >		FL101	1-517-305-11	INDICATOR TUBE, FLUORESCENT	
L251	1-410-509-11	INDUCTOR 10uH		△CNJ901	1-251-078-11	OUTLET, AC. (D915:AUS)	
		< TRANSISTOR >		△F902	1-532-237-00	FUSE, TIME LAG (T3. 15A/250V) (D915:AUS)	
Q251	8-729-119-76	TRANSISTOR 2SA1175-HFE		△F902	1-532-748-11	FUSE, GLASS TUBE (6. 3A/125V) (EXCEPT D915:AUS)	
Q252	8-729-119-76	TRANSISTOR 2SA1175-HFE		△F903	1-532-286-00	FUSE (T2. 5A/250V) (D915:AUS)	
Q253	8-729-119-76	TRANSISTOR 2SA1175-HFE		△F971	1-532-237-00	FUSE, TIME LAG (T3. 15A/250V) (D915:AUS)	
Q254	8-729-900-63	TRANSISTOR DTA124ES		△F971	1-576-107-11	FUSE (3. 15A/250V) (EXCEPT D915:AUS)	
		< RESISTOR >		△F972	1-532-237-00	FUSE, TIME LAG (T3. 15A/250V) (D915:AUS)	
R251	1-249-403-11	CARBON 68 5% 1/4W F		△F972	1-576-107-11	FUSE (3. 15A/250V) (EXCEPT D915:AUS)	
R252	1-249-429-11	CARBON 10K 5% 1/4W		△F973	1-532-748-11	FUSE, GLASS TUBE (6. 3A/125V) (EXCEPT D915:AUS)	
R253	1-247-804-11	CARBON 75 5% 1/4W		△F973	1-576-107-11	FUSE (3. 15A/250V) (EXCEPT D915:AUS)	
R254	1-249-403-11	CARBON 68 5% 1/4W F		△F974	1-532-748-11	FUSE, GLASS TUBE (6. 3A/125V) (EXCEPT D915:AUS)	
R255	1-249-429-11	CARBON 10K 5% 1/4W					
R256	1-247-804-11	CARBON 75 5% 1/4W		FE1	1-239-727-11	ENCAPSULATED COMPONENT (FCC) (EXCEPT D915:AUS)	
R257	1-249-403-11	CARBON 68 5% 1/4W F		FE1	1-239-611-11	ENCAPSULATED COMPONENT (D915:AUS)	
R258	1-249-429-11	CARBON 10K 5% 1/4W		IC621	8-759-502-33	IC SI-18752	
R259	1-247-804-11	CARBON 75 5% 1/4W		Q655	8-729-026-08	TRANSISTOR 2SC4495	
R260	1-247-804-11	CARBON 75 5% 1/4W		Q658	8-729-022-16	TRANSISTOR 2SD2390-OPY-M (D715)	
R261	1-247-811-31	CARBON 150 5% 1/4W		Q658	8-749-010-25	TRANSISTOR MN2488-OPY-M (D915)	
R262	1-247-807-31	CARBON 100 5% 1/4W		Q659	8-729-022-15	TRANSISTOR 2SB1560-OPY-M (D715)	
R263	1-247-811-31	CARBON 150 5% 1/4W		Q659	8-749-010-26	TRANSISTOR MP1620-OPY-M (D915)	
R264	1-247-807-31	CARBON 100 5% 1/4W		Q701	8-729-026-08	TRANSISTOR 2SC4495	
R265	1-247-811-31	CARBON 150 5% 1/4W		Q705	8-729-022-16	TRANSISTOR 2SD2390-OPY-M (D715)	
R266	1-247-807-31	CARBON 100 5% 1/4W		Q705	8-749-010-25	TRANSISTOR MN2488-OPY-M (D915)	
		< TERMINAL >		Q706	8-729-022-15	TRANSISTOR 2SB1560-OPY-M (D715)	
TM1	1-537-714-11	TERMINAL BOARD (ANTENNA) (D915:AUS)		Q706	8-749-010-26	TRANSISTOR MP1620-OPY-M (D915)	
TM1	1-537-734-11	TERMINAL BOARD, ANT (ANTENNA) (EXCEPT D915:AUS)		Q751	8-729-026-08	TRANSISTOR 2SC4495	
				Q755	8-729-022-16	TRANSISTOR 2SD2390-OPY-M (D715)	

△T902	1-426-756-11	TRANSFORMER, POWER (D915:US)
△T902	1-426-757-11	TRANSFORMER, POWER (D915:CND)
△T902	1-426-758-11	TRANSFORMER, POWER (D915:AUS)

The components identified by mark △ or dotted line with mark △ are critical for safety. Replace only with part number specified.	Les composants identifiés par une marque △ sont critiques pour la sécurité. Ne les remplacer que par une pièce portant le numéro spécifié.
--	--

Ref.No.	Part No.	Description	Remark
		ACCESSORIES & PACKING MATERIALS *****	
	1-467-637-11	REMOTE COMMANDER (RM-U241) (EXCEPT D915:CND)	
	1-467-638-11	REMOTE COMMANDER (RM-P341) (D915:CND)	
	1-501-374-11	ANTENNA, LOOP	
	1-501-594-11	ANTENNA (FM) (D915:AUS)	
	3-758-526-21	MANUAL, INSTRUCTION (ENGLISH)	
	3-758-526-31	MANUAL, INSTRUCTION (FRENCH) (D715:CND/D915:CND)	
	3-759-183-31	MANUAL, INSTRUCTION (ENGLISH, FRENCH) (for RM-P341) (D915:CND)	
	4-925-079-11	COVER (6), BATTERY (for REMOTE COMMANDER)	
*	4-952-676-01	CUSHION	
*	4-967-030-01	INDIVIDUAL CARTON (D715)	
*	4-967-032-01	INDIVIDUAL CARTON (D915)	

		***** HARDWARE LIST *****	
#1	7-682-548-04	SCREW +BVTT 3X8 (S)	
#2	7-682-548-09	SCREW +BVTT 3X8 (S)	
#3	7-682-561-04	SCREW +BVTT 4X8 (S)	
#4	7-685-646-79	SCREW +BVTP 3X8 TYPE2 IT-3	

STR-D715/D915

SONY
SERVICE MANUAL

US Model
Canadian Model
STR-D715/D915
Australian Model
STR-D915

SUPPLEMENT-1

File this Supplement with the Service Manual.

Subject : Circuit change
Block diagram

SCHEMATIC DIAGRAM (Service manual page 17)

 : indicates changed portion

[MAIN BOARD] ADDRESS J-2

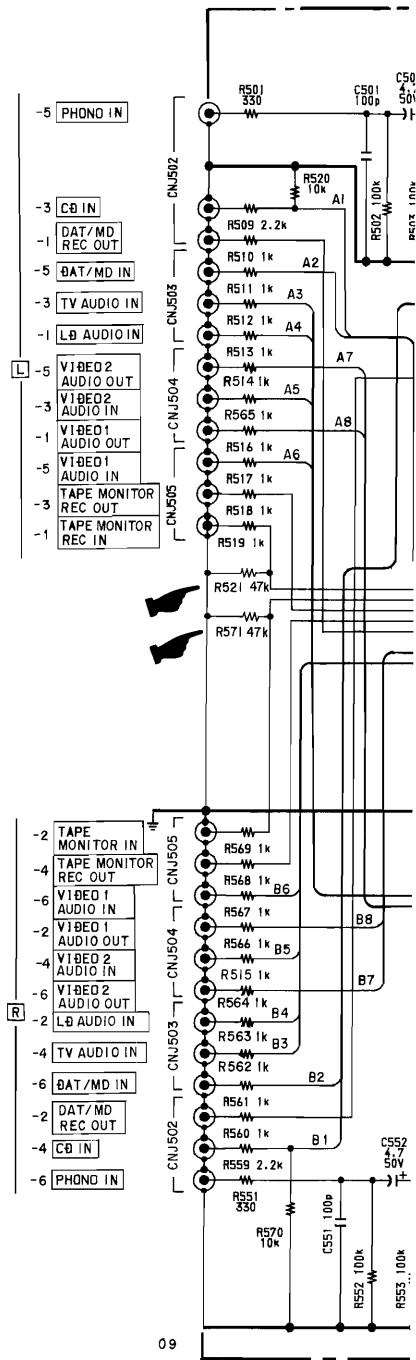

PRINTED WIRING BOARDS (Service manual page 23)

[MAIN BOARD] ADDRESS G,H-20

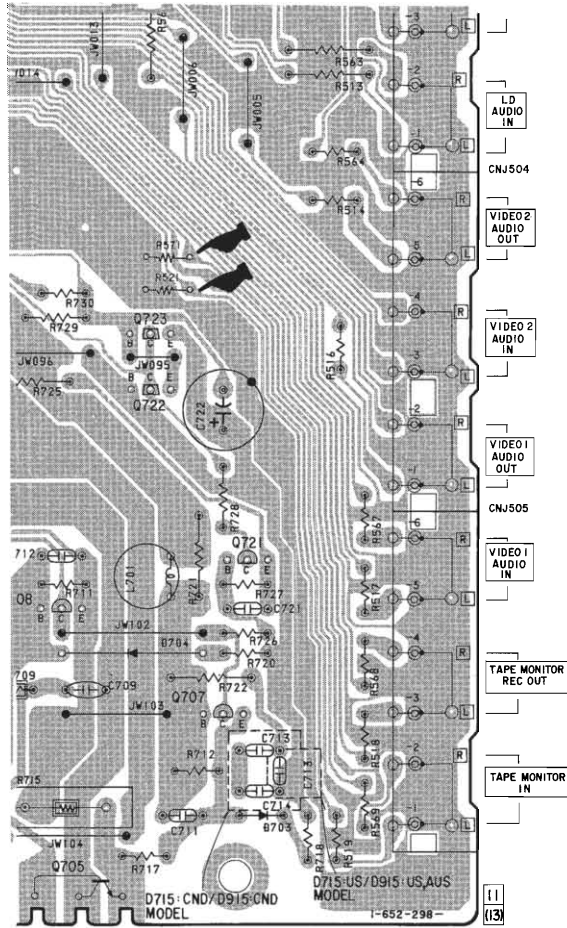

CHANGE PARTS LIST

Page	Ref. No.	Former	New
43	R521	_____	1-249-437-11 CARBON 47K 5% 1/4W
	R571	_____	1-249-437-11 CARBON 47K 5% 1/4W

• BLOCK DIAGRAM

