

STR-DA1000ES/DB790

SERVICE MANUAL

Ver. 1.4 2004.11

US Model
Canadian Model
STR-DA1000ES
AEP Model
UK Model
E Model
Australian Model
Chinese Model
STR-DB790



Photo: STR-DA1000ES

This receiver incorporates Dolby* Digital and Pro Logic Surround and the DTS** Digital Surround System.

* Manufactured under license from Dolby Laboratories.

"Dolby", "Pro Logic" and the double-D symbol are trademarks of Dolby Laboratories.

** "DTS" and "DTS Digital Surround" are registered trademarks of Digital Theater Systems, Inc.

SPECIFICATIONS

AUDIO POWER SPECIFICATIONS

POWER OUTPUT AND TOTAL HARMONIC DISTORTION: (Models of area code U only)

With 8 ohm loads, both channels driven, from 20 – 20,000 Hz; rated 100 watts per channel minimum RMS power, with no more than 0.09% total harmonic distortion from 250 milliwatts to rated output

Amplifier section

POWER OUTPUT STR-DA1000ES:

Rated Power Output at Stereo Mode
(8 ohms 20 Hz – 20 kHz, THD 0.09%) 100 W + 100 W
(4 ohms 20 Hz – 20 kHz, THD 0.09%) 80 W + 80 W
Reference Power Output

(8 ohms 20 Hz – 20 kHz, THD 0.09%)
FRONT¹⁾: 100 W + 100 W
CENTER¹⁾: 100 W
SURR¹⁾: 100 W + 100 W
SURR BACK¹⁾: 100 W + 100 W

(4 ohms 20 Hz – 20 kHz, THD 0.09%)
FRONT¹⁾: 80 W + 80 W
CENTER¹⁾: 80 W
SURR¹⁾: 80 W + 80 W
SURR BACK¹⁾: 80 W + 80 W

STR-DB790:

Rated Power Output at Stereo Mode
(8 ohms 1 kHz, THD 0.7%) 90 W + 90 W³⁾
(4 ohms 1 kHz, THD 0.7%) 80 W + 80 W³⁾
Reference Power Output²⁾

(8 ohms 1 kHz, THD 0.7%)

FRONT¹⁾: 100 W + 100 W
CENTER¹⁾: 100 W
SURR¹⁾: 100 W + 100 W
SURR BACK¹⁾: 100 W

(4 ohms 1 kHz, THD 0.7%)

FRONT¹⁾: 90 W + 90 W
CENTER¹⁾: 90 W
SURR¹⁾: 90 W + 90 W
SURR BACK¹⁾: 90 W

(8 ohms 20 Hz – 20 kHz, THD 0.09%)

FRONT¹⁾: 90 W + 90 W
CENTER¹⁾: 90 W
SURR¹⁾: 90 W + 90 W
SURR BACK¹⁾: 90 W

(4 ohms 20 Hz – 20 kHz, THD 0.09%)

FRONT¹⁾: 80 W + 80 W
CENTER¹⁾: 80 W
SURR¹⁾: 80 W + 80 W
SURR BACK¹⁾: 80 W

1) Depending on the sound field settings and the source, there may be no sound output

2) Measured under the following conditions:

Area code	Power requirements
SP, MY, CEL, CEK, AU, CN	230 V AC, 50 Hz
TW	110 V AC, 60 Hz

3) Measured under the following conditions:

Area code	Power requirements
KR	220 V AC, 50 Hz

Frequency response

PHONO	RIAA equalization curve ±0.5 dB
-------	------------------------------------

MULTI CH IN, CD/ SACD, MD/TAPE, DVD, TV/SAT, VIDEO 1, 2, 3	10 Hz – 100 kHz +0.5/-2 dB (when ANALOG DIRECT is selected)
--	--

Inputs (Analog)

PHONO	Sensitivity: 2.5 mV Impedance: 50 kilohms S/N ³⁾ : 86 dB (A, 2.5 mV ⁴⁾)
MULTI CH IN, CD/ SACD, MD/TAPE, DVD, TV/SAT, VIDEO 1, 2, 3	Sensitivity: 150 mV Impedance: 50 kilohms S/N ⁴⁾ : 96 dB (A, 150 mV ⁵⁾)

– Continued on next page –

FM STEREO FM/AM RECEIVER

9-877-370-05

2004K05-1

© 2004.11

Sony Corporation

Audio Group

Published by Sony Engineering Corporation

SONY®

STR-DA1000ES/DB790

Ver 1.1

4) INPUT SHORT

5) Weighted network, input level

Inputs (Digital)

DVD (Coaxial)	Impedance: 75 ohms S/N: 100 dB (A, 20 kHz LPF)
---------------	--

DVD, TV/SAT, MD, VIDEO3 (Optical)	S/N: 100 dB (A, 20 kHz LPF)
-----------------------------------	--------------------------------

Outputs

MD/TAPE (REC OUT), VIDEO 1, 2 (AUDIO OUT)	Voltage: 150 mV Impedance: 2.2 kilohms
---	---

SUB WOOFER	Voltage: 2 V Impedance: 1 kilohms
------------	--------------------------------------

EQ

Gain levels	±10 dB, 1 dB step
-------------	-------------------

FM tuner section

Tuning range	87.5 - 108.0 MHz
Antenna	FM wire antenna
Antenna terminals	75 ohms, unbalanced
Sensitivity	
Mono:	18.3 dBf, 2.2 μV/75 ohms
Stereo:	38.3 dBf, 22.5 μV/75 ohms
Useable sensitivity	11.2 dBf, 1 μV/75 ohms
S/N	
Mono:	76 dB
Stereo:	70 dB
Harmonic distortion at 1 kHz	
Mono:	0.3%
Stereo:	0.5%
Separation	45 dB at 1 kHz
Frequency response	30 Hz - 15 kHz, +0.5/-2 dB
Selectivity	60 dB at 400 kHz

AM tuner section

Tuning range	
STR-DA1000ES:	530 - 1,710 kHz ⁶⁾ (With 10-kHz tuning scale) 531 - 1,710 kHz ⁶⁾ (With 9-kHz tuning scale)
STR-DB790:	531 - 1,602 kHz (With 9-kHz tuning scale)
Antenna	Loop antenna
Usable sensitivity	50 dB/m (at 1,000 kHz or 999 kHz)
S/N	54 dB (at 50 mV/m)
Harmonic distortion	0.5% (50 mV/m, 400 Hz)
Selectivity	
At 9 kHz:	35 dB
At 10 kHz:	40 dB

6) You can change the AM tuning scale to 9 kHz or 10 kHz. After tuning in any AM station, turn off the receiver. While holding down PRESET TUNING + or TUNING +, press I/⏻. All preset stations will be erased when you change the tuning scale. To reset the scale to 10 kHz (or 9 kHz), repeat the procedure.

Video section

Inputs/Outputs	
Video:	1 Vp-p, 75 ohms
S-video:	Y: 1 Vp-p, 75 ohms C: 0.286 Vp-p, 75 ohms
COMPONENT VIDEO:	Y: 1 Vp-p, 75 ohms B-Y: 0.7 Vp-p, 75 ohms R-Y: 0.7 Vp-p, 75 ohms

General

Power requirements

Area code	Power requirements
U, CA	120 V AC, 60 Hz
CEL, CEK, AU	230 V AC, 50/60 Hz
SP, MY, KR, CN	220 - 230 V AC, 50/60 Hz
TW	110 V AC, 60 Hz

Power consumption

Area code	Power consumption
U	290 W
CA	340 VA
CEL, CEK, AU	290 W
SP, MY, KR, CN	290 W
TW	290 W

Power consumption (during standby mode)

1 W

AC outlets

Area code	AC outlets
U, CA	1 switched, 120 W/1A MAX
SP, MY, TW	1 switched, 100 W MAX

Dimensions 430 161 400 mm
including projecting parts
and controls

Mass (Approx) 14.5 kg

Supplied accessories

FM wire antenna (1)
AM loop antenna (1)
STR-DA1000ES:
Remote commander RM-LG112 (1)
R6 (size-AA) batteries (2)
STR-DB790:
Remote commander RM-PP412 (1)
R6 (size-AA) batteries (2)

Design and specifications are subject to change without notice.

NOTE: Abbreviation

AU : Australian model
CA : Canadian model
CEK : UK model
CEL : AEP model
CN : Chinese model
KR : Korean model
MY : Malaysia model
SP : Singapore model
TW : Taiwan model
U : US model

Notes on chip component replacement

- Never reuse a disconnected chip component.
- Notice that the minus side of a tantalum capacitor may be damaged by heat.

SAFETY CHECK-OUT

After correcting the original service problem, perform the following safety check before releasing the set to the customer: Check the antenna terminals, metal trim, “metallized” knobs, screws, and all other exposed metal parts for AC leakage. Check leakage as described below.

LEAKAGE TEST

The AC leakage from any exposed metal part to earth ground and from all exposed metal parts to any exposed metal part having a return to chassis, must not exceed 0.5 mA (500 microamperes.). Leakage current can be measured by any one of three methods.

1. A commercial leakage tester, such as the Simpson 229 or RCA WT-540A. Follow the manufacturers' instructions to use these instruments.
2. A battery-operated AC milliammeter. The Data Precision 245 digital multimeter is suitable for this job.
3. Measuring the voltage drop across a resistor by means of a VOM or battery-operated AC voltmeter. The “limit” indication is 0.75 V, so analog meters must have an accurate low-voltage scale. The Simpson 250 and Sanwa SH-63Trd are examples of a passive VOM that is suitable. Nearly all battery operated digital multimeters that have a 2 V AC range are suitable. (See Fig. A)

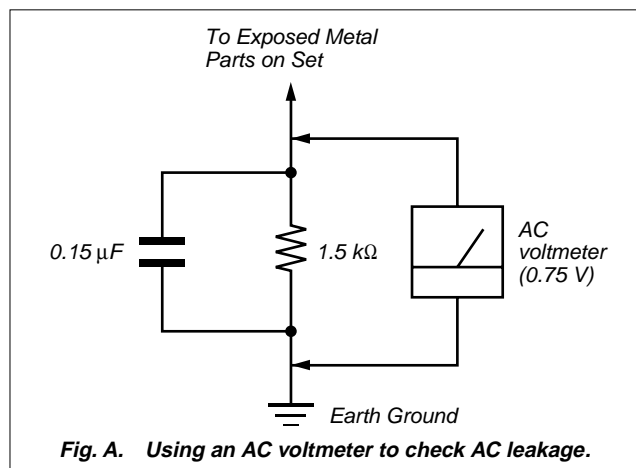
**UNLEADED SOLDER**

Boards requiring use of unleaded solder are printed with the lead-free mark (LF) indicating the solder contains no lead. (Caution: Some printed circuit boards may not come printed with the lead free mark due to their particular size)

LF : LEAD FREE MARK

Unleaded solder has the following characteristics.

- Unleaded solder melts at a temperature about 40 °C higher than ordinary solder.
Ordinary soldering irons can be used but the iron tip has to be applied to the solder joint for a slightly longer time. Soldering irons using a temperature regulator should be set to about 350 °C.
Caution: The printed pattern (copper foil) may peel away if the heated tip is applied for too long, so be careful!
- Strong viscosity
Unleaded solder is more viscous (sticky, less prone to flow) than ordinary solder so use caution not to let solder bridges occur such as on IC pins, etc.
- Usable with ordinary solder
It is best to use only unleaded solder but unleaded solder may also be added to ordinary solder.

与安全有关的零部件须知

在原理图上用阴影及 \triangle 标记来识别的零部件在安全操作上是具有关键性的。这些零部件要用本手册中所示的部件号对应的索尼零部件进行更换。

在安全操作上具有关键性的电路调整与索尼公司出版的维修手册完全一致。在更换关键零部件时或怀疑动作失常时，请进行这些调整操作。

SAFETY-RELATED COMPONENT WARNING!!

COMPONENTS IDENTIFIED BY MARK \triangle OR DOTTED LINE WITH MARK \triangle ON THE SCHEMATIC DIAGRAMS AND IN THE PARTS LIST ARE CRITICAL TO SAFE OPERATION. REPLACE THESE COMPONENTS WITH SONY PARTS WHOSE PART NUMBERS APPEAR AS SHOWN IN THIS MANUAL OR IN SUPPLEMENTS PUBLISHED BY SONY.

ATTENTION AU COMPOSANT AYANT RAPPORT À LA SÉCURITÉ!

LES COMPOSANTS IDENTIFIÉS PAR UNE MARQUE \triangle SUR LES DIAGRAMMES SCHÉMATIQUES ET LA LISTE DES PIÈCES SONT CRITIQUES POUR LA SÉCURITÉ DE FONCTIONNEMENT. NE REMPLACER CES COMPOSANTS QUE PAR DES PIÈCES SONY DONT LES NUMÉROS SONT DONNÉS DANS CE MANUEL OU DANS LES SUPPLÉMENTS PUBLIÉS PAR SONY.

TABLE OF CONTENTS

1. SERVICING NOTES	5	6-32. Printed Wiring Boards	
2. GENERAL	7	– DISPLAY/FUN/VOL Boards –	50
Location of Controls	7	6-33. Schematic Diagram	
3. DISASSEMBLY		– DISPLAY/FUN/VOL Boards –	51
3-1. Disassembly Flow	10	6-34. Printed Wiring Boards	
3-2. Case (414535)	11	– DC1/DC2/TH/4/8 SW Boards –	52
3-3. COMP-V Board	11	6-35. Schematic Diagram	
3-4. Back Panel Block	12	– DC1/DC2/TH/4/8 SW Boards –	53
3-5. Main Block	12	6-36. Printed Wiring Boards	
3-6. DIGITAL Board	13	– AC/PRI/SEC1/SEC3 Boards –	54
3-7. STAY-3/STAY-4/SP-B/SP-A/S-VIDEO/ VIDEO/VIDEO-AU/AU-IN Board	14	6-37. Schematic Diagram	
3-8. MAIN Board	14	– AC/PRI/SEC1/SEC3 Boards –	55
4. TEST MODE	15	6-38. IC Pin Function Description	63
5. ELECTRICAL ADJUSTMENT	17	6. EXPLODED VIEWS	
6. DIAGRAMS		7-1. Case Section	70
6-1. Block Diagram – TUNER/VIDEO Section –	19	7-2. Chassis Section-1	71
6-2. Block Diagram – AUDIO DSP Section –	20	7-3. Chassis Section-2	72
6-3. Block Diagram – AUDIO CONTROL Section –	21	7-4. Main Block Section	73
6-4. Block Diagram – AUDIO AMP Section –	22	7-5. MAIN Board Block	74
6-5. Block Diagram		7-6. Chassis Section-3	75
– DISPLAY/KEY CONTROL Section –	23	7-7. Front Panel Block-1	76
6-6. Block Diagram – POWER SUPPLY Section –	24	7-8. Front Panel Block-2	77
6-7. Note for Printed Wiring Boards and Schematic Diagrams	25	7-9. Front Panel Block-3	78
6-8. Printed Wiring Board		8. ELECTRICAL PARTS LIST	79
– DIGITAL Board (Component Side) –	26		
6-9. Printed Wiring Board			
– DIGITAL Board (Conductor Side) –	27		
6-10. Schematic Diagram – DIGITAL Board (1/4) –	28		
6-11. Schematic Diagram – DIGITAL Board (2/4) –	29		
6-12. Schematic Diagram – DIGITAL Board (3/4) –	30		
6-13. Schematic Diagram – DIGITAL Board (4/4) –	31		
6-14. Printed Wiring Boards			
– VIDEO/VIDEO-AU Boards –	32		
6-15. Schematic Diagram			
– VIDEO/VIDEO-AU Boards –	33		
6-16. Printed Wiring Boards – HP-V3/S-VIDEO Boards – ...	34		
6-17. Schematic Diagram – HP-V3/S-VIDEO Boards –	35		
6-18. Printed Wiring Board – COMP-V Board –	36		
6-19. Schematic Diagram – COMP-V Board –	37		
6-20. Printed Wiring Board – AU-IN Board –	38		
6-21. Schematic Diagram – AU-IN Board –	39		
6-22. Printed Wiring Board – MAIN Board –	40		
6-23. Schematic Diagram – MAIN Board (1/3) –	41		
6-24. Schematic Diagram – MAIN Board (2/3) –	42		
6-25. Schematic Diagram – MAIN Board (3/3) –	43		
6-26. Printed Wiring Board – A-CLASS Board –	44		
6-27. Schematic Diagram – A-CLASS Board –	45		
6-28. Printed Wiring Boards			
– SBL/STAY/STAY2 Boards –	46		
6-29. Schematic Diagram			
– SBL/STAY/STAY2 Boards –	47		
6-30. Printed Wiring Boards			
– SP-A/SP-B/STAY3/STAY4 Boards –	48		
6-31. Schematic Diagram			
– SP-A/SP-B/STAY3/STAY4 Boards –	49		

SECTION 1 SERVICING NOTES

• **MODEL IDENTIFICATION**

– Back Panel –



Model	PART No.
DB790 : AEP, UK and Australian models	4-245-425-0□
DB790 : Singapore and Malaysia models	4-245-425-1□
DB790 : Taiwan model	4-245-425-2□
DB790 : Chinese model	4-245-425-3□
DB790 : Korean model	4-245-425-4□
DA1000ES: US model	4-245-425-6□
DA1000ES: Canadian model	4-245-425-7□

ERROR MESSAGES

If there is a malfunction, the display shows a code of two numbers and a message. You can check the condition of the system by message. Refer to the following table to solve the problem.

messages	cause and response
DEC. EROR	Appears when the signal which the receiver can not decode (example DSD-CD) is input when “DEC.” is set to “DEC. PCM”. Set to “DEC. AUTO”.
PROTECT	Irregular current output to the speakers. Turn off the receiver and check the speaker connection. Then turn on the power again. Be comes this display, When short current flowed with breakage of the power MOS, or when detection resistor becomes open in connection with it.

SERVICE POSITION

[Connecting the clip for GND]

When checking without back panel, it is necessary to connect the clip for GND to a chassis.

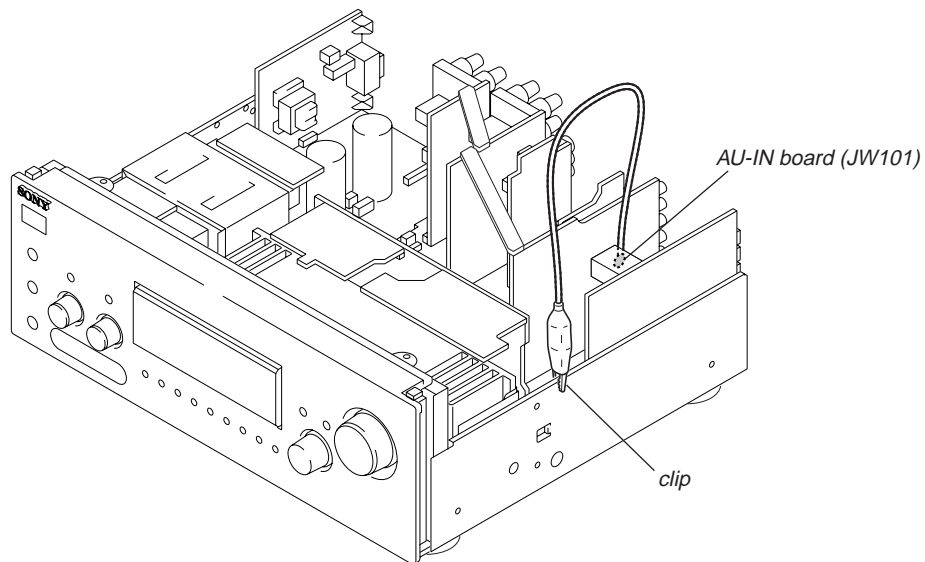

It is necessary to remove cord bushing from back panel.

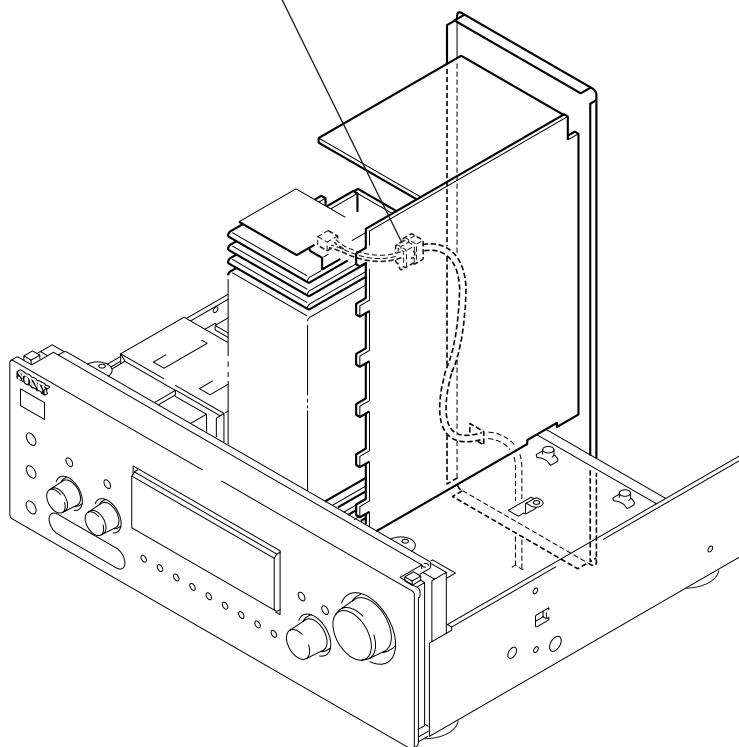

SECTION 2 GENERAL

This section is extracted from instruction manual.

LOCATION OF CONTROLS

– Front Panel –

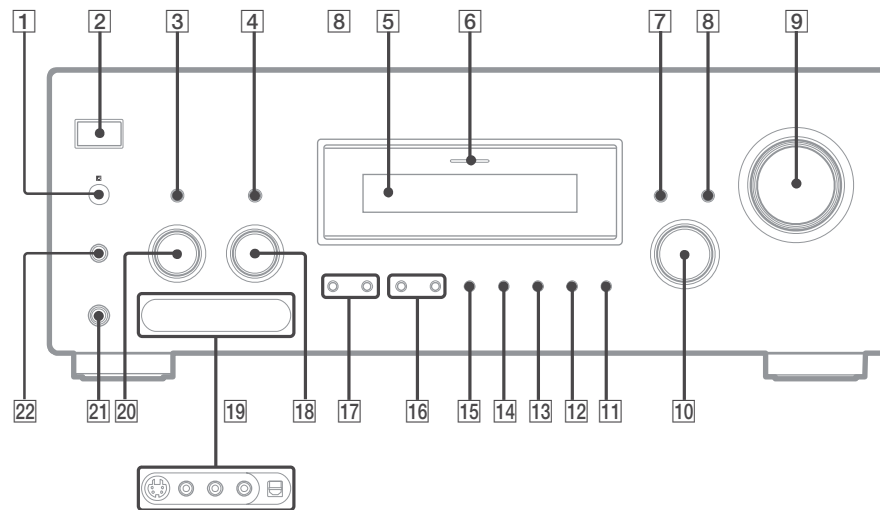

- | | |
|---|----------------------|
| A.F.D. 13 | 2CH 14 |
| DISPLAY 7 | -/+ 18 |
| Display 5 | I/⏻ (power) 2 |
| INPUT MODE 8 | |
| INPUT SELECTOR 10 | |
| IR receptor 1 | |
| MAIN MENU 3 | |
| MASTER VOLUME -/+ 9 | |
| MEMORY/ENTER 4 | |
| MENU 20 | |
| MOVIE 12 | |
| MULTICHANNEL DECODING
indicator 6 | |
| MUSIC 11 | |
| PHONES jack 21 | |
| PRESET TUNING -/+ 17 | |
| SPEAKERS 22 | |
| SURREAR BACK DECODING 15 | |
| TUNING -/+ 16 | |
| VIDEO 3 INPUT jacks 19 | |

– Remote Commander (RM-LG112) (STR-DA1000ES) –

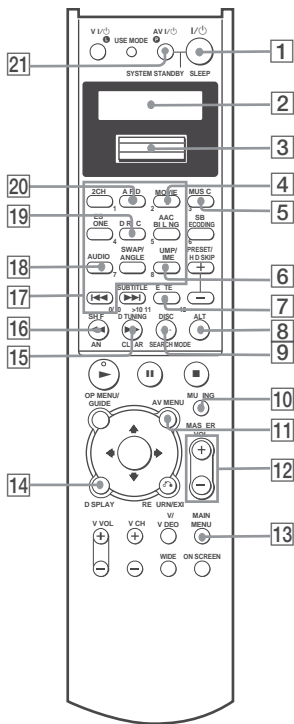

I/O [1]

Press to turn the receiver on or off.

A.F.D. [20]

Press to set the receiver to automatically select the appropriate decoding mode for the input signal.

ALT [8]

Press to change remote key function to activate those buttons with orange printing.

ANT* (After pressing ALT) [16]

When you selected VCR, press to select output signal from antenna terminal TV signal or VCR program.

AUDIO [18]

Changing the sound to Multiplex, Bilingual or Multi channel TV sound.

AV MENU [11]

Press to display the menus of the VCR, satellite tuner, or DVD.

AV I/O [21]

Press to turn the selected audio and video components on or off.

If you press the I/O switch at the same time, it will turn off the receiver and other Sony audio/video components (SYSTEM STANDBY).

Note

The function of the AV I/O switch changes automatically each time you select the input with the easy scroll key ([3]). Depending on the component, the above operation may not be possible or may operate differently than described.

CLEAR* (After pressing ALT) [15]

When you selected CD player or DVD player, press if you made a mistake when you press the numeric buttons or press to return to the continuous play, etc.

D.TUNING* [15]

When you selected tuner, press to enter direct tuning mode.

DIRECT [19]

Press to select DIRECT function.

DISC* [9]

When you selected CD player or video CD player, press to select a disc directly (multi-disc changer only).

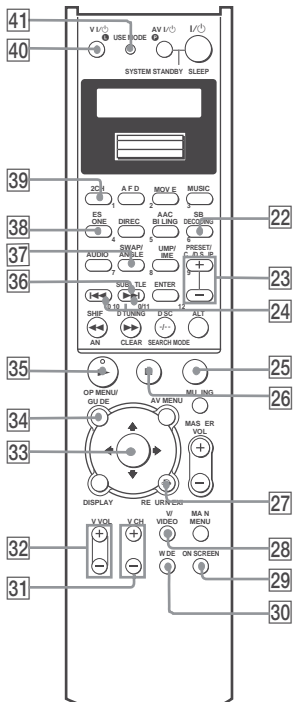

ON SCREEN [29]

Press to display the menus of the receiver on the TV screen (only for the models with on screen function).

PRESET/CH/D.SKIP +/- [23]

If you selected tuner:

Press to scan and select preset stations.

If you selected TV, VCR, or satellite tuner:

Press to select preset channels.

If you selected CD player, video CD player, DVD player, or MD deck:

Press to skip discs (multi-disc changer only).

RETURN ↵/EXIT [27]

After pressing MAIN MENU, AV MENU, or TOP MENU/GUIDE, press to return to the previous menu or exit the menu.

SB DECODING [22]

Press to select surround back decoding mode.

SEARCH MODE* [9]

When you selected DVD player, press to select the search mode. Press to select the unit for search (track, index, etc.).

SHIFT [16]

When you selected tuner, press repeatedly to select a memory page for presetting radio stations or tuning to preset stations.

SLEEP (After pressing ALT) [1]

Press repeatedly to activate the sleep function and select the duration which the receiver turns off automatically.

SUBTITLE* (After pressing ALT) [36]

When you selected DVD player, press to change the subtitles.

SWAP**/ANGLE* [37]

If you selected TV:
Press to swap the small and large pictures (only for Sony TVs with picture-in-picture function).

If you selected DVD player:
Press to select viewing angle or changing the angles.

DISPLAY [14]

Press to select the information displayed on the display of the receiver or TV screen.

Display [2]

Select the input, macro list and command mode of the remote.

Easy scroll key [3]

Move to select the input and press to enter the selection. The components are factory assigned to the inputs as follows. When you want to assign other components, program the remote following the steps on "Programming the remote" on page 9.

Input(s)	Assigned component(s)
VIDEO 1	VCR (VTR mode 3)
VIDEO 2	VCR (VTR mode 1)
VIDEO 3	VCR (VTR mode 2)
DVD	DVD player
TV/SAT	TV tuner
TAPE	Tape deck (B)
MD/DAT	MD deck
CD/SACD	CD player
TUNER	Built-in tuner
PHONO	Turntable
MULTI	Component connected to the multi channel input jacks on the receiver
M1, M2*	(Macro list)

* For details, see page 13.

See the table on page 8 for information on the buttons that you can use to control each component.

Note that the inputs are factory-set as described in the table above. If you want to change the factory setting of the buttons to match your particular components, do the procedure "Programming the remote" on page 9.

ENTER (After pressing ALT) [7]

After selecting a channel, disc or track using the numeric buttons, press to enter the value.

JUMP/TIME* [6]

If you selected TV:

TEST TONE [38]

Press to output a test tone.

TOP MENU/GUIDE* [34]

Press to display DVD titles or guide menus.

TV/VIDEO [28]

Press to select the TV to input signal TV input or video input.

TV CH +/- [31]

Press to select preset TV channels.

TV VOL +/- [32]

Press to adjust the volume of TV.

TV I/O [40]

Press to turn the TV on or off.

USE MODE [41]

Press to set up the remote.

WIDE [30]

Press to switch the TV to the wide mode.

2CH [39]

Press to turn the sound field off and listen to 2 channel stereo sound. Multi channel source is also downmixed to a 2 channel stereo sound.

>10/11* (After pressing ALT) [35]

When you selected CD player, video CD player, LD player, MD deck, or tape deck, press to select track number over 10.

-/- [9]

When you selected TV, press to select the channel entry mode, either one or two digit.

▶/▶/▶/ENTER/EXECUTE [33]

After pressing MAIN MENU, AV MENU, or TOP MENU/GUIDE, use the button to make specific settings, then press the button to enter the selection.

▷ [35]

Press to start play. (Press to start play on the front sides of the cassette.)

Press to toggle between the previous and the current channels.

If you selected CD player, video CD player, or DVD player:

Press to display the time information.

MAIN MENU [13]

Press to select the menu of the receiver.

MASTER VOL +/- [12]

Press to adjust the volume level of all speakers at the same time.

MOVIE [4]

Press to select the sound fields for movies.

MUSIC [5]

Press to select the sound fields for music.

MUTING [10]

Press to mute the sound.

Numeric buttons (1-9, 0/10)* (After pressing ALT) [17]

If you selected tuner:

Use with SHIFT to select tuner preset station numeric input during DIRECT TUNING or MEMORY mode.

If you selected CD player, video CD player, DVD player, MD deck, or DAT deck:

Press to select track numbers. 0/10 selects track 10.

If you selected TV, VCR, or satellite tuner:

Press to select channel numbers.

* The function of these buttons switch automatically each time you select the input with the easy scroll key ([3]). Depending on the component, the above operation may not be possible or may operate differently than described.

|| [26]

Press to pause play or recording, or press to start recording when the component is in recording standby.

■ [25]

Press to stop play.

◀▶ [24]

Press to skip tracks.

◀▶▶▶ [15/16]

Press to fast-forward or rewind.

Press to search tracks in the forward or backward direction.

* The function of these buttons switch automatically each time you select the input with the easy scroll key ([3]). Depending on the component, the above operation may not be possible or may operate differently than described.

** Only for Sony TVs with the picture-in-picture function.

Notes

- The AAC BI-LING and 12 buttons are not available.
- Some buttons may not be used depending on the model.
- The above explanation is intended to serve as an example only. Therefore, depending on the component the above operation may not be possible or may operate differently than described.
- To activate the buttons with orange printing, press ALT first before pressing the buttons.
- Before you use the ▶/▶/▶/ENTER/EXECUTE button for receiver operation, press MAIN MENU. To operate other components, press TOP MENU/GUIDE or AV MENU after selecting the input.

– Remote Commander (RM-PP412) (STR-DB790) –

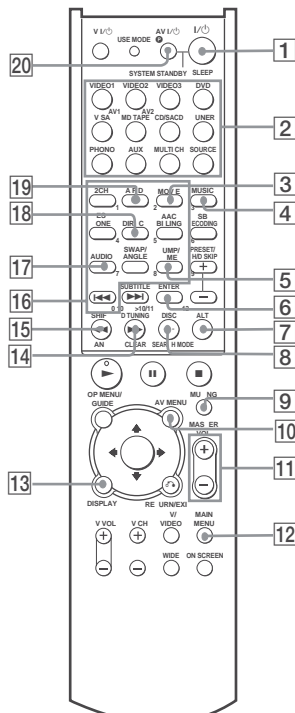

I/O 1
Press to turn the receiver on or off.

A.F.D. 19
Press to set the receiver to automatically select the appropriate decoding mode for the input signal.

ALT 17
Press to change remote key function to activate those buttons with orange printing.

ANT* (After pressing ALT) 15
When you selected VCR, press to select output signal from antenna terminal TV signal or VCR program.

AUDIO 17
Changing the sound to Multiplex, Bilingual or Multi channel TV sound.

AV MENU 10
Press to display the menus of the VCR, satellite tuner, or DVD.

AV I/O switch 20
Press to turn the selected audio and video components on or off.
If you press the I/O switch at the same time, it will turn off the receiver and other Sony audio/video components (SYSTEM STANDBY).

Note
The function of the AV I/O switch changes automatically each time you select the input with the input buttons (2). Depending on the component, the above operation may not be possible or may operate differently than described.

CLEAR* (After pressing ALT) 14
When you selected CD player or DVD player, press if you made a mistake when you press the numeric buttons or press to return to the continuous play, etc.

D.TUNING 14
When you selected tuner, press to enter direct tuning mode.

DIRECT 18
Press to select DIRECT function.

DISC 8
When you selected CD player or video CD player, press to select a disc directly (multi-disc changer only).

ON SCREEN 28
Press to display the menus of the receiver on the TV screen (only for the models with on screen function).

PRESET/CH/D.SKIP +/- 22
If you selected tuner:
Press to scan and select preset stations.
If you selected TV, VCR, or satellite tuner:
Press to select preset channels.
If you selected CD player, video CD player, DVD player, or MD deck:
Press to skip discs (multi-disc changer only).

RETURN/EXIT 26
After pressing MAIN MENU, AV MENU, or TOP MENU/GUIDE, press to return to the previous menu or exit the menu.

SB DECODING 21
Press to select surround back decoding mode.

SEARCH MODE 8
When you selected DVD player, press to select the search mode. Press to select the unit for search (track, index, etc.).

SHIFT 15
When you selected tuner, press repeatedly to select a memory page for presetting radio stations or tuning to preset stations.

SLEEP (After pressing ALT) 1
Press repeatedly to activate the sleep function and select the duration which the receiver turns off automatically.

SUBTITLE* (After pressing ALT) 35
When you selected DVD player, press to change the subtitles.

DISPLAY 13
Press to select the information displayed on the display of the receiver or TV screen.

ENTER (After pressing ALT) 6
After selecting a channel, disc or track using the numeric buttons, press to enter the valve.

Input buttons 2
Press to select the input. Use AV 1 and AV 2 to select the command mode of the remote.
The components are factory assigned to the inputs as follows. When you want to assign other components, program the remote following the steps on "Programming the remote" on page 9.

Input(s)	Assigned component(s)
VIDEO 1	VCR (VTR mode 3)
VIDEO 2	VCR (VTR mode 1)
VIDEO 3	VCR (VTR mode 2)
DVD	DVD player
TV/SAT	TV tuner
MD/TAPE	MD deck / Tape deck (B)
CD/SACD	CD player
TUNER	Built-in tuner
PHONO	Turntable
AUX	Other audio component
MULTI CH	Component connected to the multi channel input jacks on the receiver

See the table on page 8 for information on the buttons that you can use to control each component.
Note that the inputs are factory-set as described in the table above. If you want to change the factory setting of the buttons to match your particular components, do the procedure "Programming the remote" on page 9.

JUMP/TIME 5
If you selected TV:
Press to toggle between the previous and the current channels.
If you selected CD player, video CD player, or DVD player:
Press to display the time information.

SWAP*/ANGLE 36
If you selected TV:
Press to swap the small and large pictures (only for Sony TVs with picture-in-picture function).
If you selected DVD player:
Press to select viewing angle or changing the angles.

TEST TONE 37
Press to output a test tone.

TOP MENU/GUIDE 33
Press to display DVD titles or guide menus.

TV/VIDEO 27
Press to select the TV to input signal TV input or video input.

TV CH +/- 30
Press to select preset TV channels.

TV VOL +/- 31
Press to adjust the volume of TV.

TV I/O 39
Press to turn the TV on or off.

USE MODE 40
Press to set up the remote.

WIDE 29
Press to switch the TV to the wide mode.

2CH 38
Press to turn the sound field off and listen to 2 channel stereo sound. Multi channel source is also downmixed to a 2 channel stereo sound.

>10/11* (After pressing ALT) 35
When you selected CD player, video CD player, LD player, MD deck, or tape deck, press to select track number over 10.

MAIN MENU 12
Press to select the menu of the receiver.

MASTER VOL +/- 11
Press to adjust the volume level of all speakers at the same time.

MOVIE 3
Press to select the sound fields for movies.

MUSIC 4
Press to select the sound fields for music.

MUTING 9
Press to mute the sound.

Numeric buttons (1-9, 0/10)* (After pressing ALT) 16
If you selected tuner:
Use with SHIFT to select tuner preset station numeric input during DIRECT TUNING or MEMORY mode.
If you selected CD player, video CD player, DVD player, MD deck, or DAT deck:
Press to select track numbers. 0/10 selects track 10.
If you selected TV, VCR, or satellite tuner:
Press to select channel numbers.

* The function of these buttons switch automatically each time you select the input (2). Depending on the component, the above operation may not be possible or may operate differently than described.

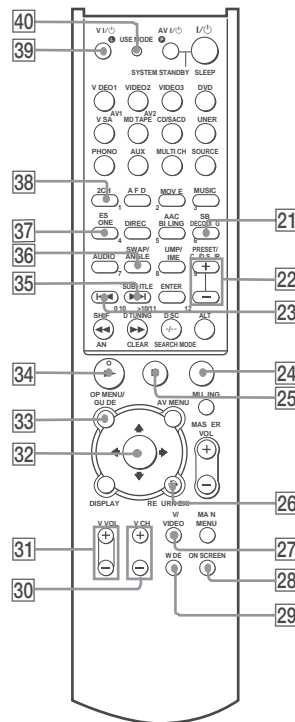

OP MENU/GUIDE 9
Press to display the menus of the VCR, satellite tuner, or DVD.

MU. NO. 10
Press to display the menus of the VCR, satellite tuner, or DVD.

MAS. ER. 11
Press to display the menus of the VCR, satellite tuner, or DVD.

RE. UNRES. 11
Press to display the menus of the VCR, satellite tuner, or DVD.

DISP. 13
Press to select the information displayed on the display of the receiver or TV screen.

V. VOL. 31
Press to adjust the volume of TV.

V. CH. 30
Press to select preset TV channels.

MA. N. MENU. 12
Press to select the menu of the receiver.

WIDE. 29
Press to switch the TV to the wide mode.

ON SCREEN. 28
Press to display the menus of the receiver on the TV screen (only for the models with on screen function).

-/+ 8
When you selected TV, press to select the channel entry mode, either one or two digit.

ENTER/EXECUTE 6
After pressing MAIN MENU, AV MENU, or TOP MENU/GUIDE, use the button to make specific settings, then press the button to enter the selection.

▶ 34
Press to start play. (Press to start play on the front sides of the cassette.)

■ 25
Press to pause play or recording, or press to start recording when the component is in recording standby.

■ 24
Press to stop play.

◀▶ 23
Press to skip tracks.

◀▶ 14/15
Press to fast-forward or rewind.
Press to search tracks in the forward or backward direction.

* The function of these buttons switch automatically each time you select the input (2). Depending on the component, the above operation may not be possible or may operate differently than described.
** Only for Sony TVs with the picture-in-picture function.

Notes

- The AAC BI-LING, SOURCE and 12 buttons are not available.
- Some buttons may not be used depending on the model.
- The above explanation is intended to serve as an example only. Therefore, depending on the component the above operation may not be possible or may operate differently than described.
- To activate the buttons with orange printing, press ALT first before pressing the buttons.
- Before you use the ENTER/EXECUTE button for receiver operation, press MAIN MENU. To operate other components, press TOP MENU/GUIDE or AV MENU after selecting the input.

SECTION 3 DISASSEMBLY

• This set can be disassembled in the order shown below.

3-1. DISASSEMBLY FLOW

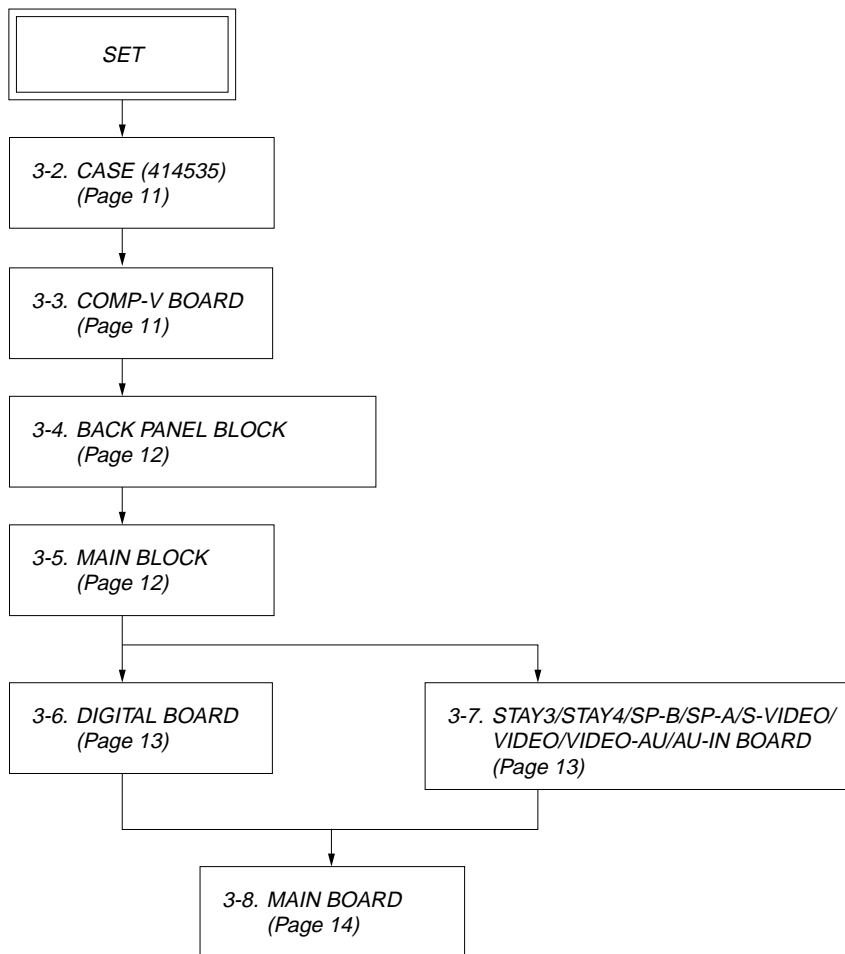

Note: Follow the disassembly procedure in the numerical order given.

3-2. CASE (414535)

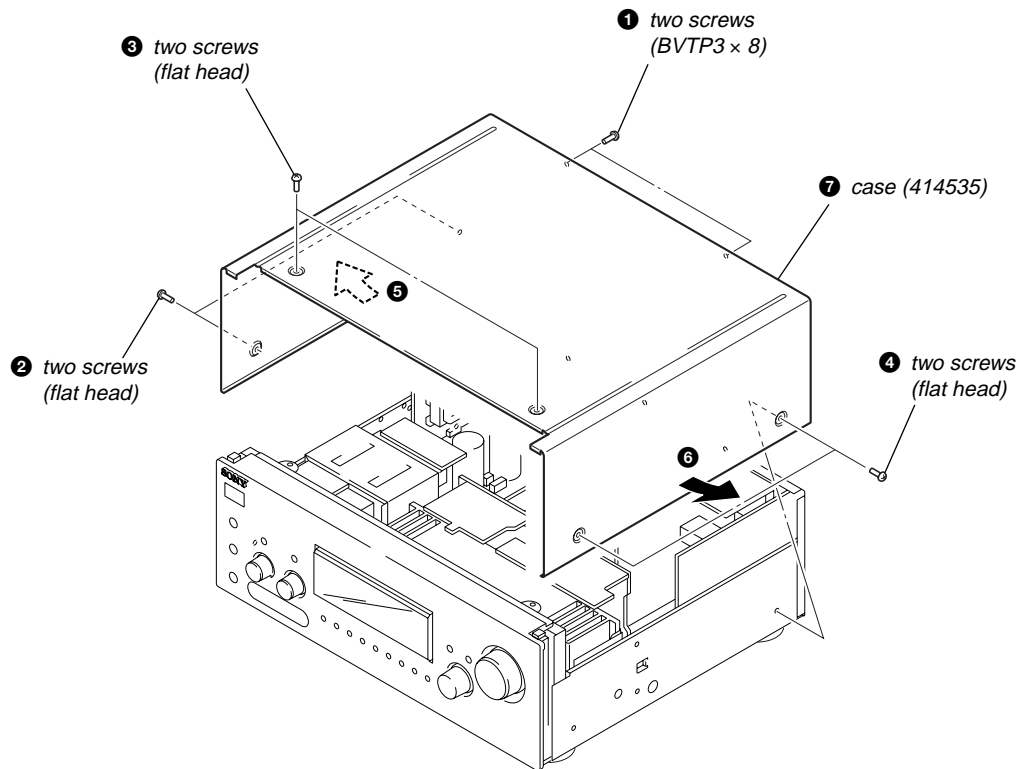

3-3. COMP-V BOARD

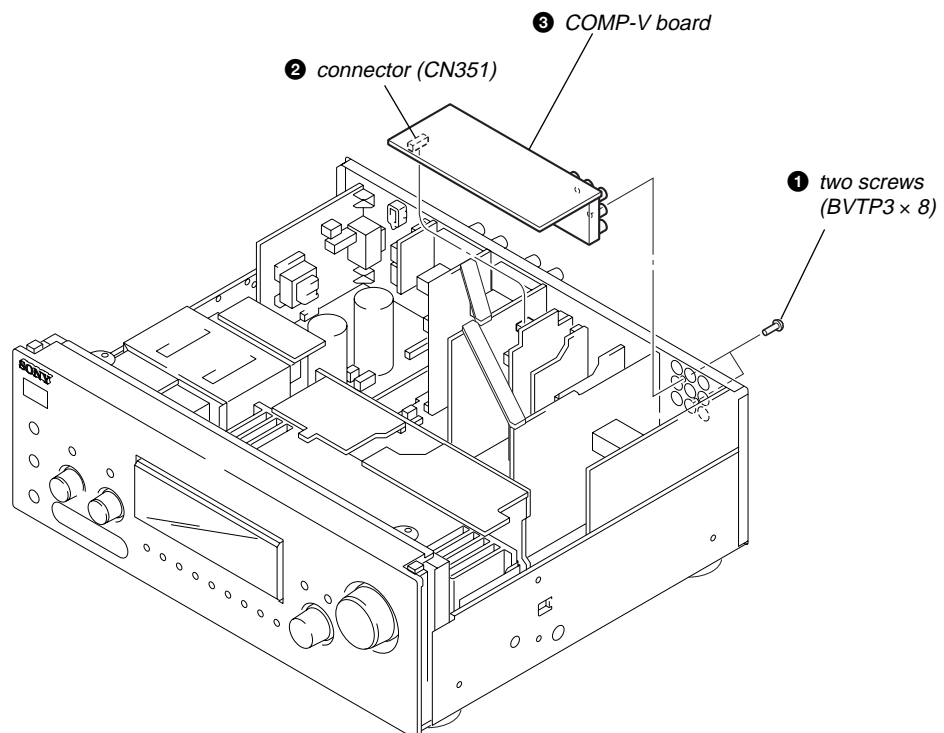

3-4. BACK PANEL BLOCK

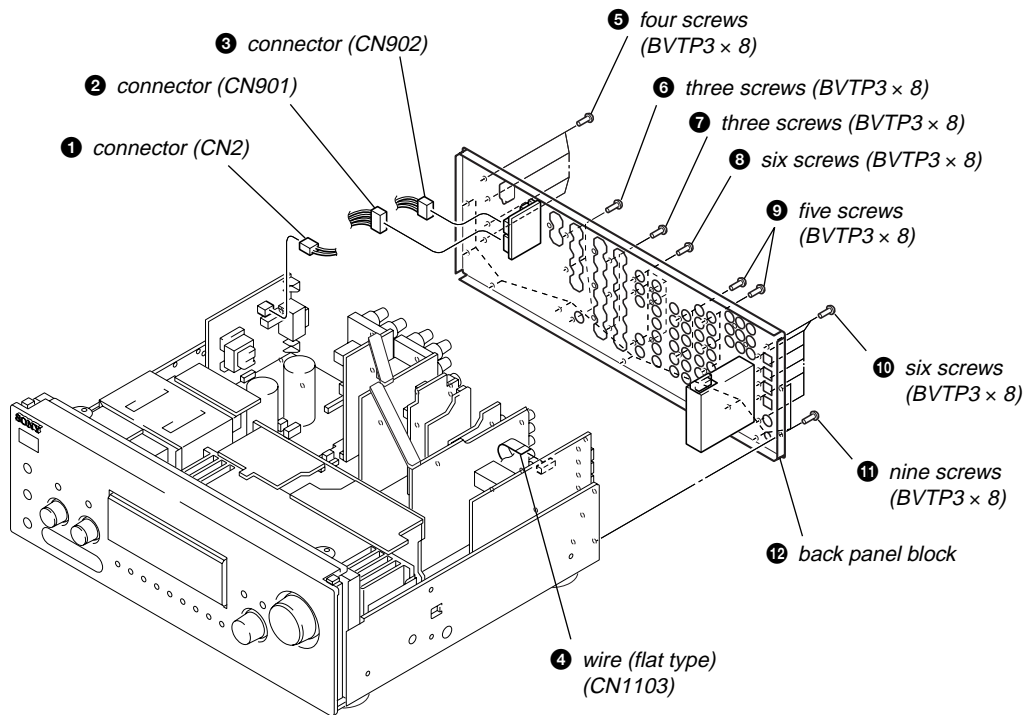

3-5. MAIN BLOCK

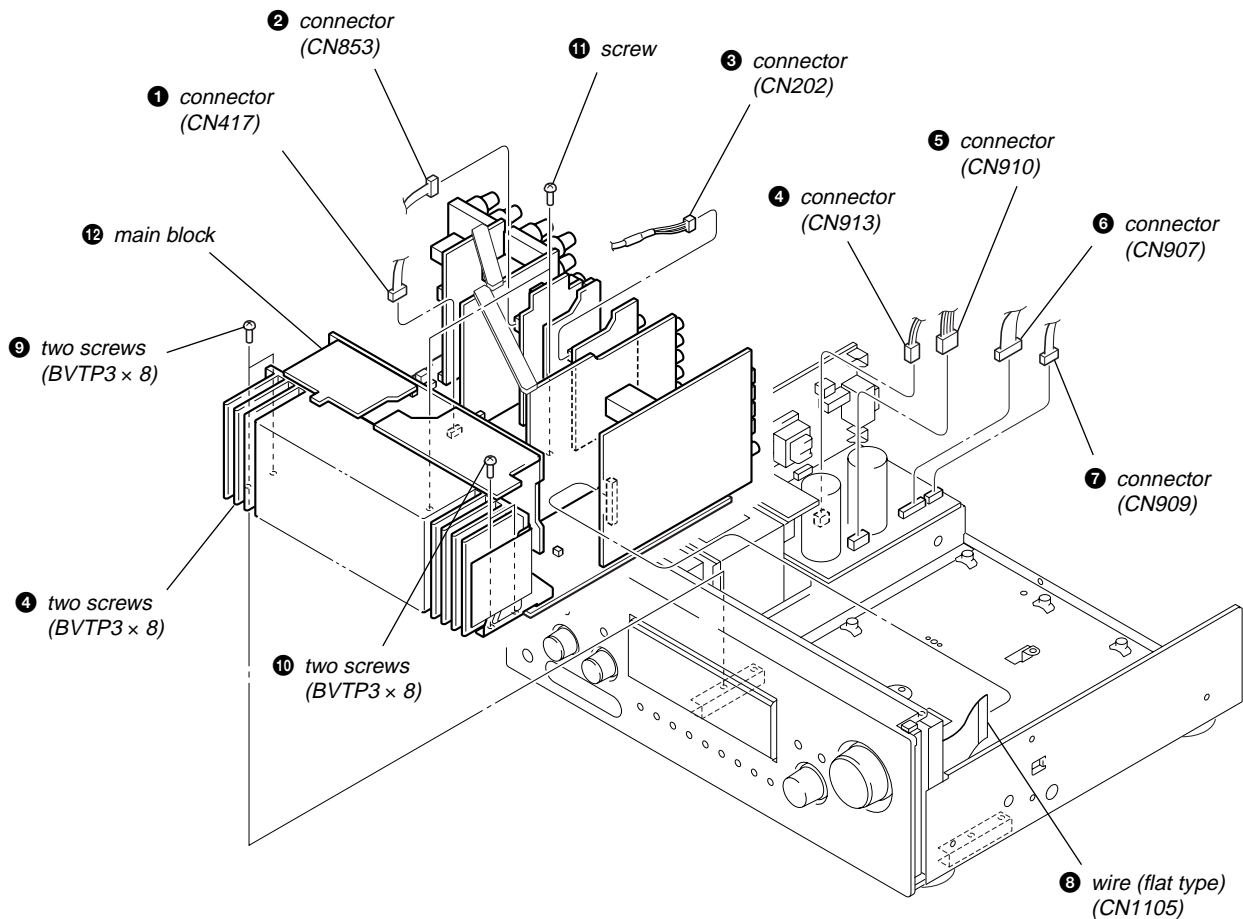

3-6. DIGITAL BOARD

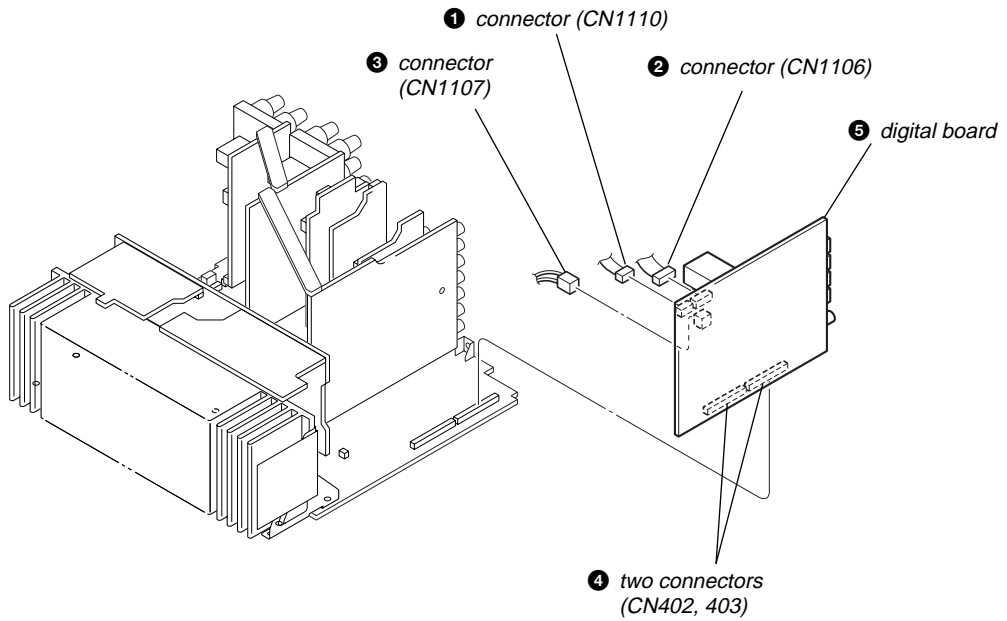

3-7. STAY3/STAY4/SP-B/SP-A/S-VIDEO/VIDEO/VIDEO-AU/AU-IN BOARD

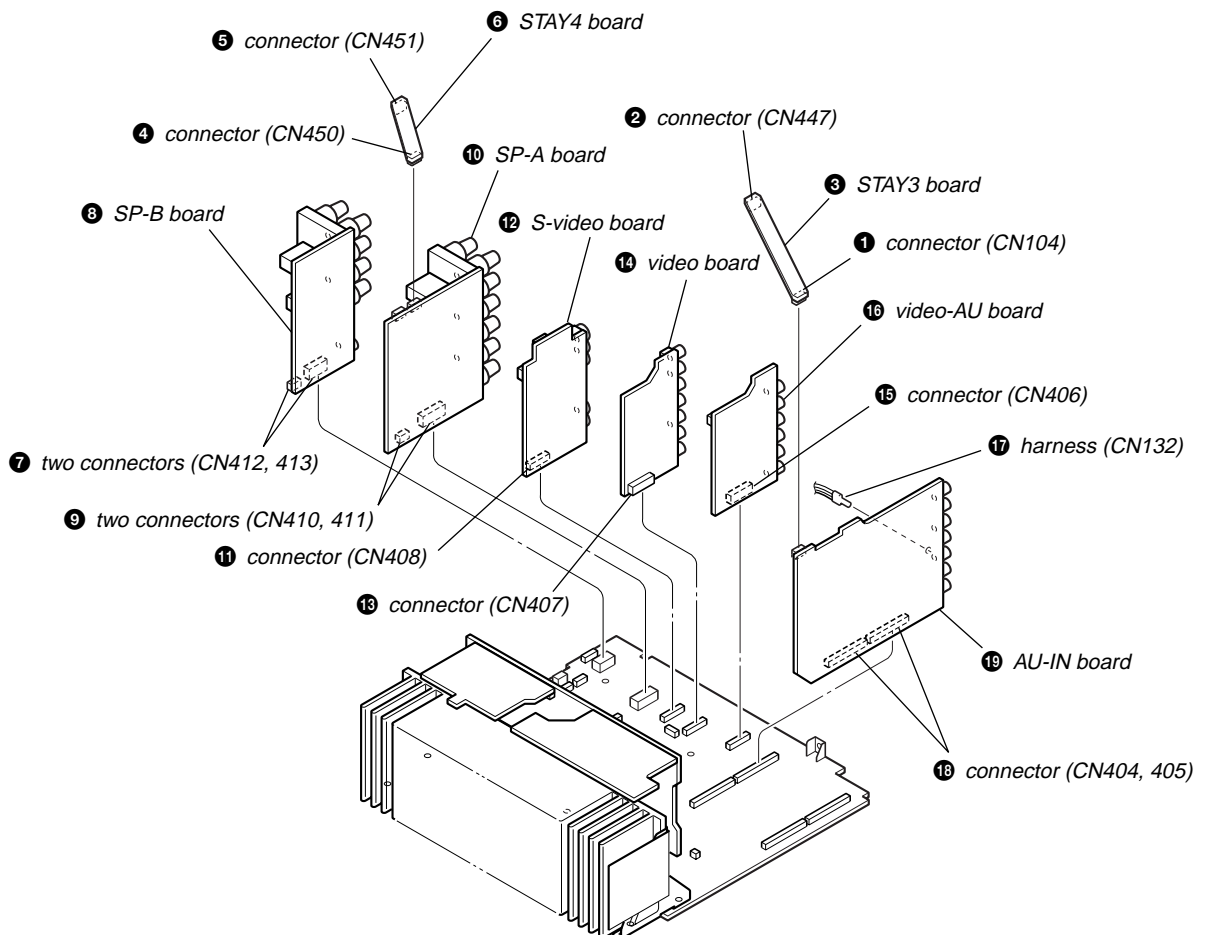

3-8. MAIN BOARD

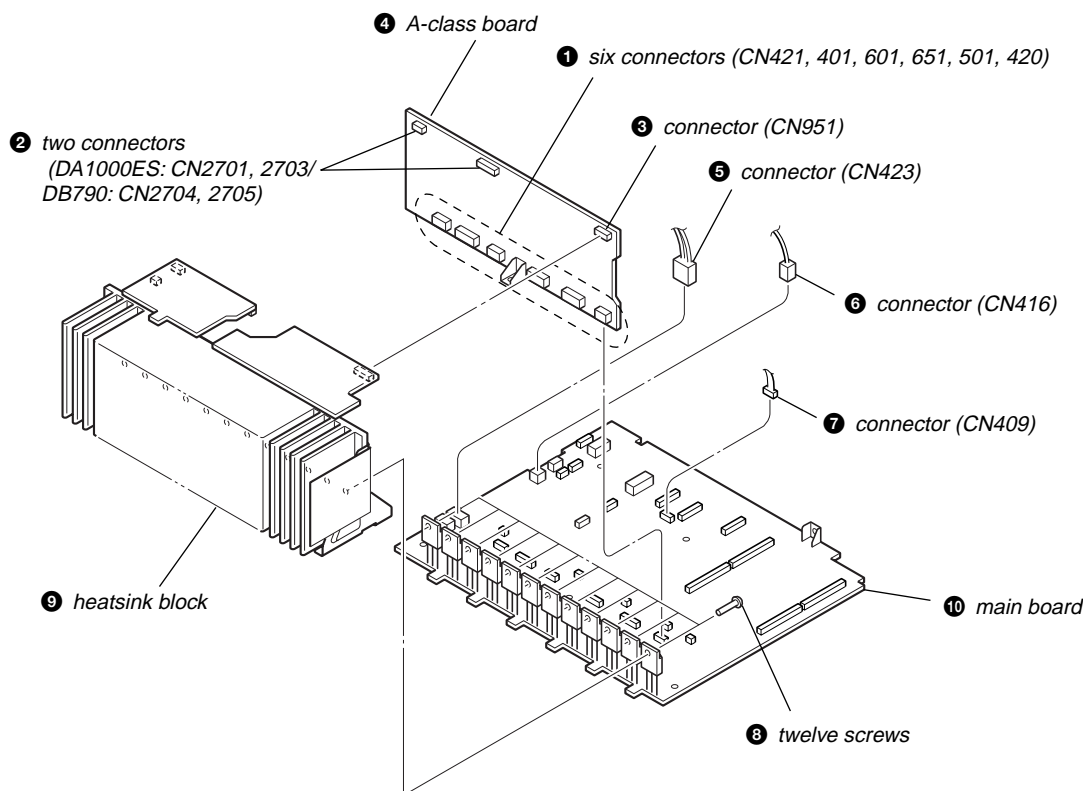

SECTION 4 TEST MODE

TUNER FACTORY PRESET MODE

All preset contents are reset to the default setting.

Procedure:

1. While pressing the **[SURR BACK DECODING]** and **[PRE-SET TUNING -]** buttons, press the **[I/⏻]** button to turn on the main power.
2. The message "FACTORY" appears and the present contents are reset to the default values.

TUNER AM STEP CHANGE (9 kHz/10 kHz) MODE (STR-DA1000ES)

Either the 9 kHz step or 10 kHz step can be selected for the AM channel step.

Procedure:

1. Press the **[I/⏻]** button to turn on the main power.
2. Turn the **[INPUT SELECTOR]** dial to select the "AM"
3. Press the **[I/⏻]** button to turn off the main power.
4. While pressing the **[PRESET TUNING +]** or **[TUNING +]** button, press the **[I/⏻]** button to turn on the main power.
5. Either the message "9 K STEP" or "10 K STEP" appears. Select the desired step.

TUNER AUTOBETICAL TUNING MODE (STR-DB790: AEP and UK models)

Procedure:

1. While pressing the **[MEMORY/ENTER]** button, press the **[I/⏻]** button to turn on the main power.
2. The message "AUTO-BETICAL SELECT" appears and scans and stores all the FM and FM RDS stations in the broadcast area.
3. When done, the message "FINISH" appears.

SOUND FIELD CLEAR MODE

The preset sound field is cleared when this mode is activated. Use this mode before returning the product to clients upon completion of repair.

Procedure:

1. While pressing the **[MUSIC]** button, press the **[I/⏻]** button to turn on the main power.
2. The message "SF. CLR." appears and initialization is performed.

ALL CLEAR MODE

All preset contents are cleared when this mode is activated. Use this mode before returning the product to clients upon completion of repair.

Procedure:

1. While pressing the **[INPUT MODE]** and **[MEMORY/ENTER]** buttons, press the **[I/⏻]** button or press the **[I/⏻]** button for more than five seconds to turn on the main power.
2. The message "INITIAL" appears and the memories are reset to the default values.

VOLUME CHECK MODE

Procedure:

1. Enter the swap mode. (Refer to the "DSP TEST MODE" (see page 16))
2. Press the **[DISPLAY]** button.
3. The message "-00dB" appears. (Volume level is "MIN")
4. Press the **[DISPLAY]** button once again.
5. The message "-58.0dB" appears. (Volume level is "MID")
6. Press the **[DISPLAY]** button once again.
7. The message "0.0dB" appears. (Volume level is "MAX")

FLUORESCENT INDICATOR TUBE PATTERN CHECK MODE

All fluorescent segments are tested. When this test is activated, all segments turn on at the same time, then each segment turns on one after another.

Procedure:

1. While pressing the **[DISPLAY]** and **[MEMORY/ENTER]** buttons, press the **[I/⏻]** button to turn on the main power.
2. All segments and **[MULTI CHANNEL DECODING]** indicator LED turn on.
3. Turn the **[INPUT SELECTOR]** dial.
4. Half of segments turn on and **[MULTI CHANNEL DECODING]** indicator LED turn off.
5. Turn the **[INPUT SELECTOR]** dial once again.
6. Others half of segments and **[MULTI CHANNEL DECODING]** indicator LED turn on.
7. Turn the **[INPUT SELECTOR]** dial once again.
8. All segments and **[MULTI CHANNEL DECODING]** indicator LED turn off.

KEY CHECK MODE

When this mode is used, the destination and the software version number are displayed.

Procedure:

1. While pressing the **[MAIN MENU]** and **[DISPLAY]** buttons, press the **[I/⏻]** button to turn on the main power.
2. The message "REST 14" appears.
3. Every pressing of any button other than the **[I/⏻]** button counts down the buttons. The buttons which are already counted once are not counted again.
4. When all buttons are pressed, the message "REST 00" appears.

SHIPMENT MODE

All preset contents are cleared when this mode is activated. Use this mode before returning the product to clients upon completion of repair.





Procedure:

1. While pressing the **[TUNING +]** and **[MUSIC]** buttons, press the **[I/⏻]** button to turn on the main power.
2. The memories are reset to the default values and the main power turn off automatically after seven minutes.

DSP TEST MODE

Procedure:

1. Press the  button to turn on the main power, then while pressing the **MEMORY/ENTER** button, press the **SURR BACK DE-CODING** button.
2. The message “SPECIAL” appears.
3. Each time the **MENU** dial is turned clockwise, the item is switched in order as follows .

Items	Display	Remark
Destination and software	**** XXX	****: destination, XXX: software version
Model name	DA1000 or DB790	Never change (IF changed, INITIALIZE works every AC on)
Destination change	DES. XXXX	XXXX: destination
Command mode change	C.MODE.AV1 or C.MODE.AV2	
Volgate limiter working level	V.LIM. > XX	Never change
Power control after protector on	PROT.EVER or PROT.OFF	When PROTECTOR works, system power is automatically down after 5 sec for safety (Set “Ever On” for the servicing)
SWAP	SWP. XXXX	Switching with  dial
Bass management	BM. XXXX	AUTO, OFF, 1 to 28 (switching with  dial)
Co-ef. Read address	RA.12XXX	Turn the  dial to switch the read data address
Co-ef. Read data	RD.XXXXXX xx	Value is read data
Co-ef. Write address	WA.12XXX	Turn the  dial to switch the write data address
Co-ef. Write data	WD.XXXXXX xx	Turn the  dial to set the write data
Total operation time	TTL-XXXX xx	4 large character is hour, 2 small character is minutes
Longest power on time	LNG-XXXX XX	
Volume < - 50 dB time display	V50-XXXX XX	
Volume < - 40 dB time display	V40-XXXX XX	
Volume < - 30 dB time display	V30-XXXX XX	
Volume < - 20 dB time display	V20-XXXX XX	
Volume < - 10 dB time display	V10-XXXX XX	
Volume < 0 dB time display	V00-XXXX XX	
Protector count value	PROT XXX	0 to 255
EEPROM condition	E-XXXXX	S RST (super reset, first time use EEPROM, test pattern corrupted) FAIL (EEPROM read/write with microprocessor have problem) V CHG (software version change) D CHG (destination/model change) CLEAR (back up data initialize) NORM (normal AC on)
EEPROM read	E-XXX-XX	First four hex code is EEPROM address Last two hex code is EEPROM data
EEPROM super reset	S.RST-YES or S.RST-NO	Not used for the servicing When EEPROM initialization is required, perform the “all clear mode” (see page 15)

SECTION 5 ELECTRICAL ADJUSTMENT

BIAS ADJUSTMENT

Condition:

input signal: no signal (no load)
volume: minimum

Connection

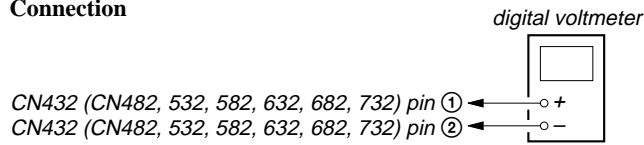

Procedure:

1. Connect a digital voltmeter to the CN432 (CN482, CN532, CN582, CN632, CN682) on the MAIN board or CN732 on the SBL board (STR-DA1000ES only).
2. Press the button to turn on the main power.
3. Adjust the RV431 (RV481, RV531, RV581, RV631, RV681) on the MAIN board or RV731 on the SBL board (STR-DA1000ES only) so that the digital voltmeter reading is 2 ± 0.5 mV.

Note: When the adjusting voltage is higher than 2 ± 0.5 mV, adjust the voltage to the minimum voltage.

Adjustment and Connection Location:

– MAIN BOARD (Component Side) –

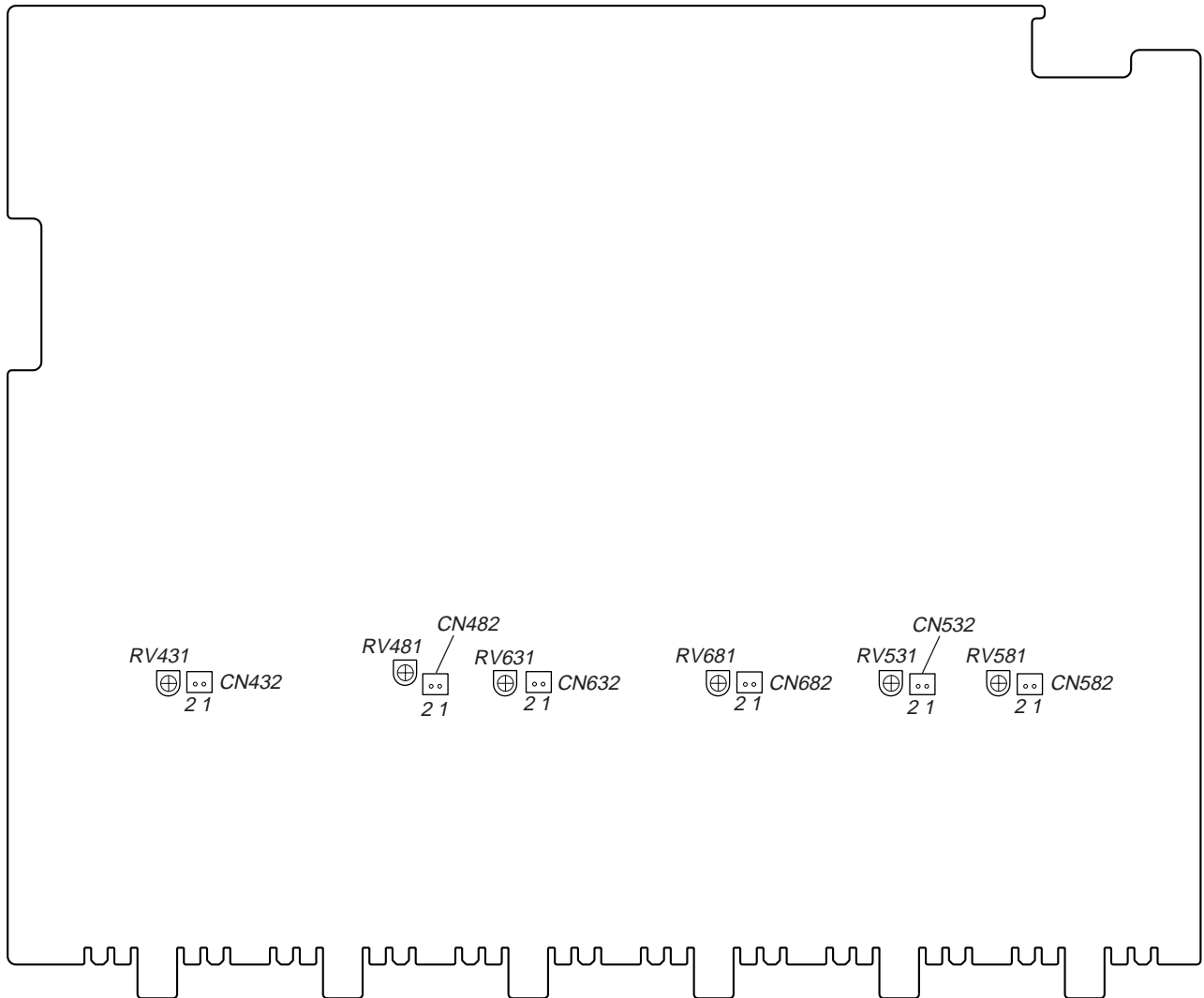

– SBL BOARD (Component Side) –

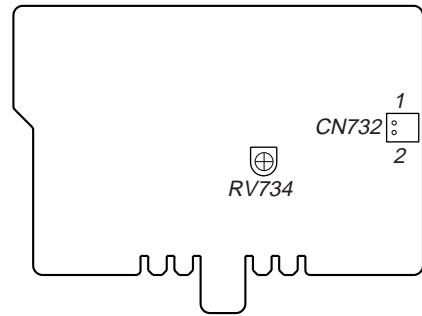

MEMO

SECTION 6
DIAGRAMS

6-1. BLOCK DIAGRAM – TUNER/VIDEO Section –

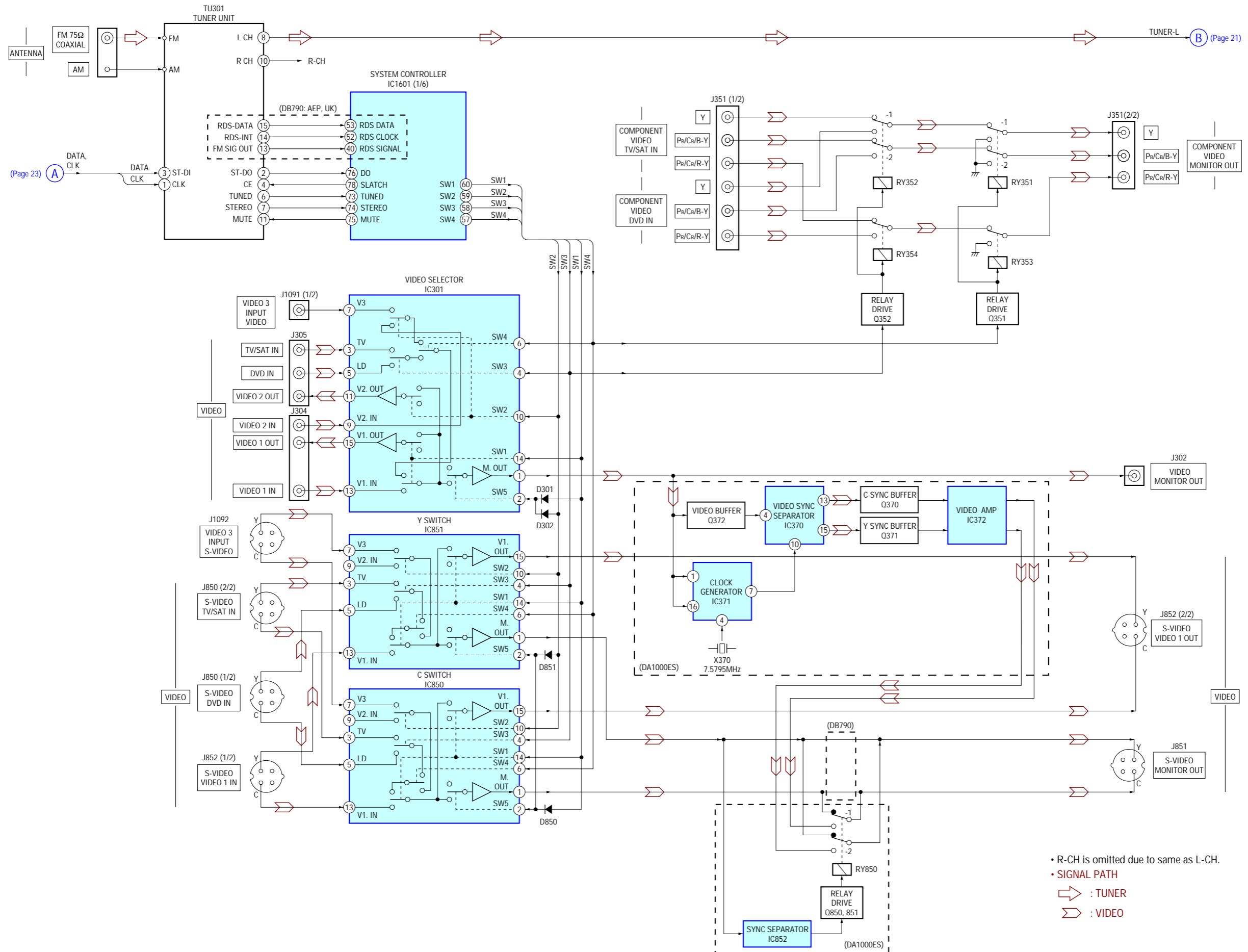

6-2. BLOCK DIAGRAM – AUDIO DSP Section –

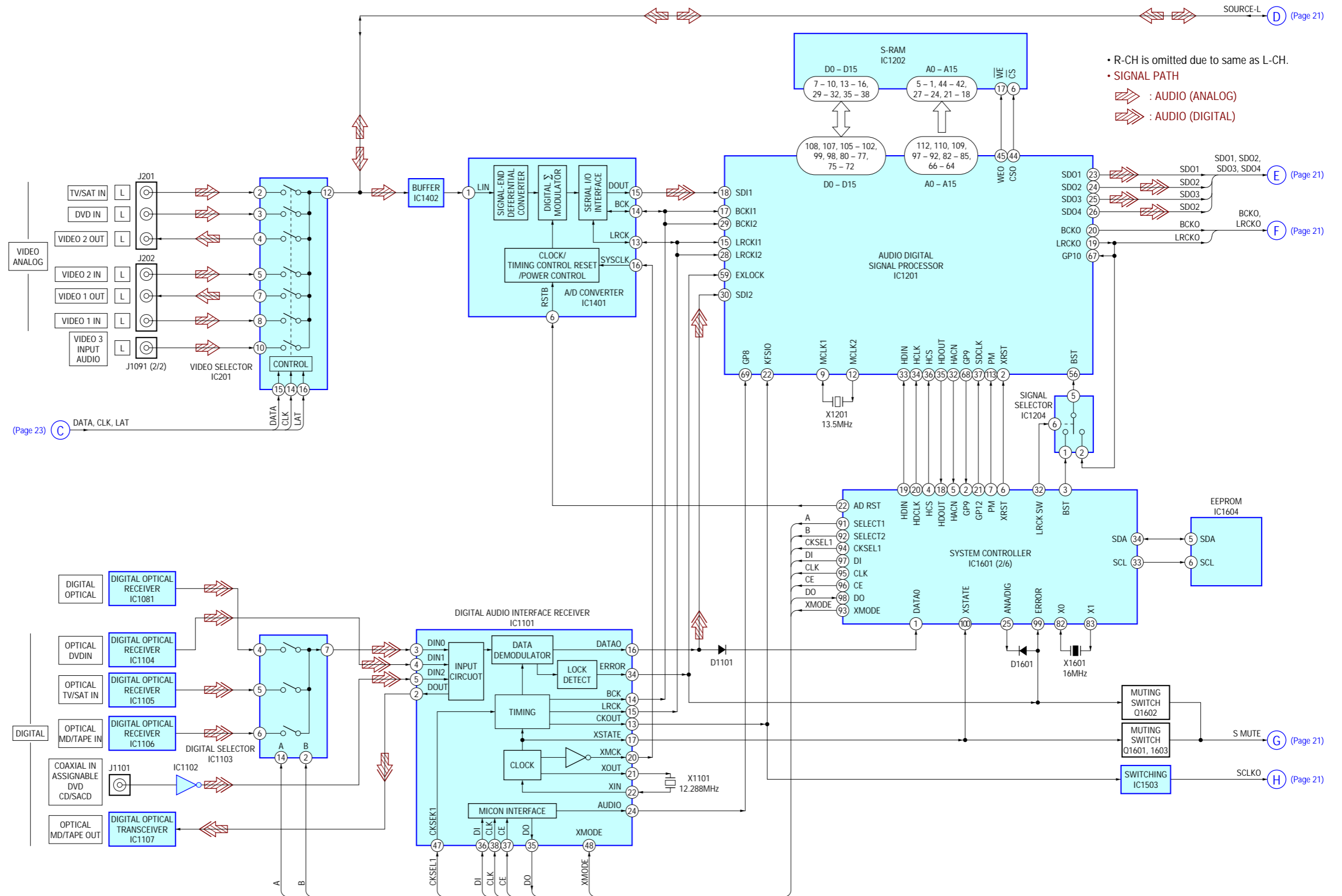

6-3. BLOCK DIAGRAM – AUDIO CONTROL Section –

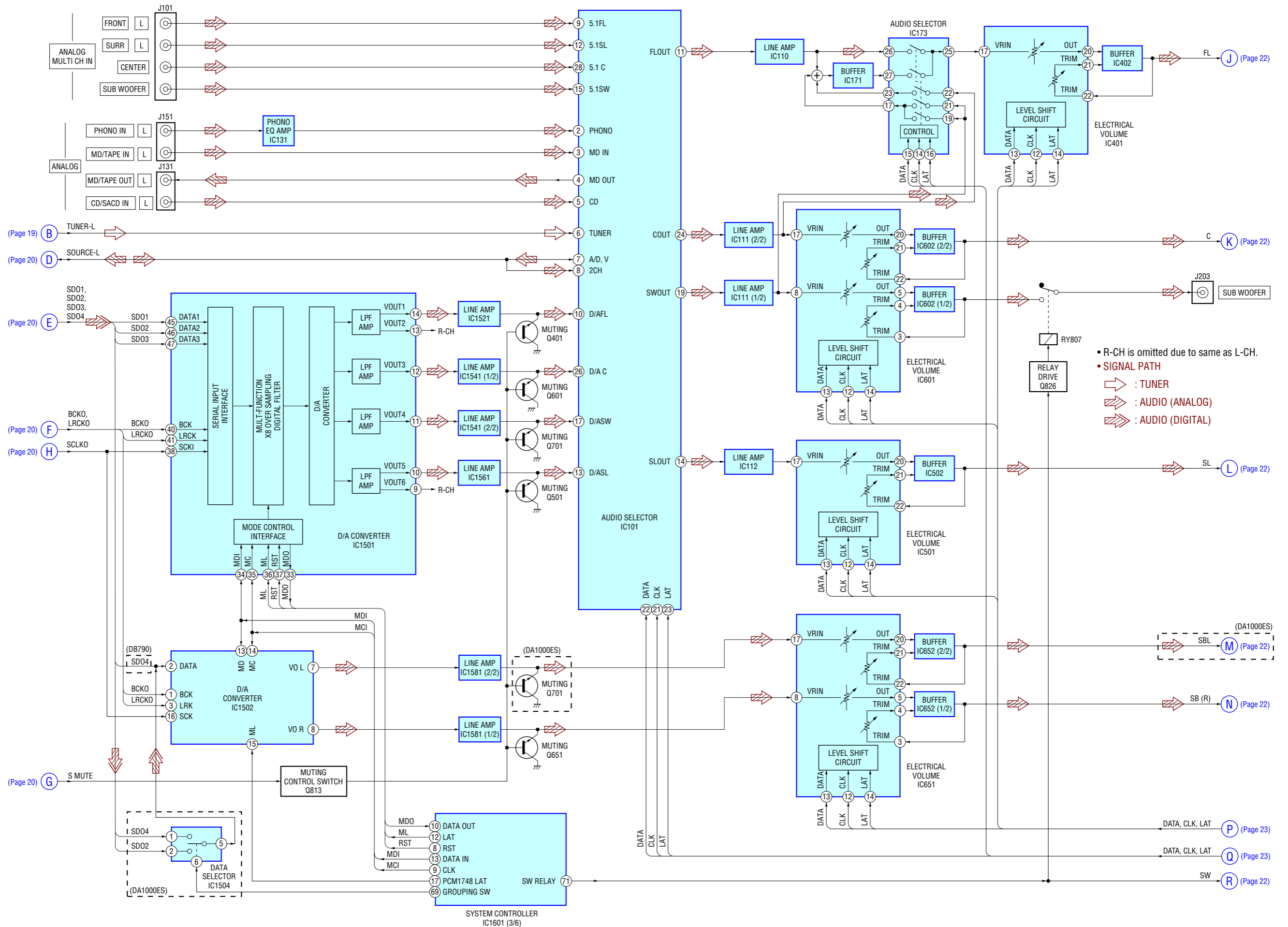

6-4. BLOCK DIAGRAM – AUDIO AMP Section –

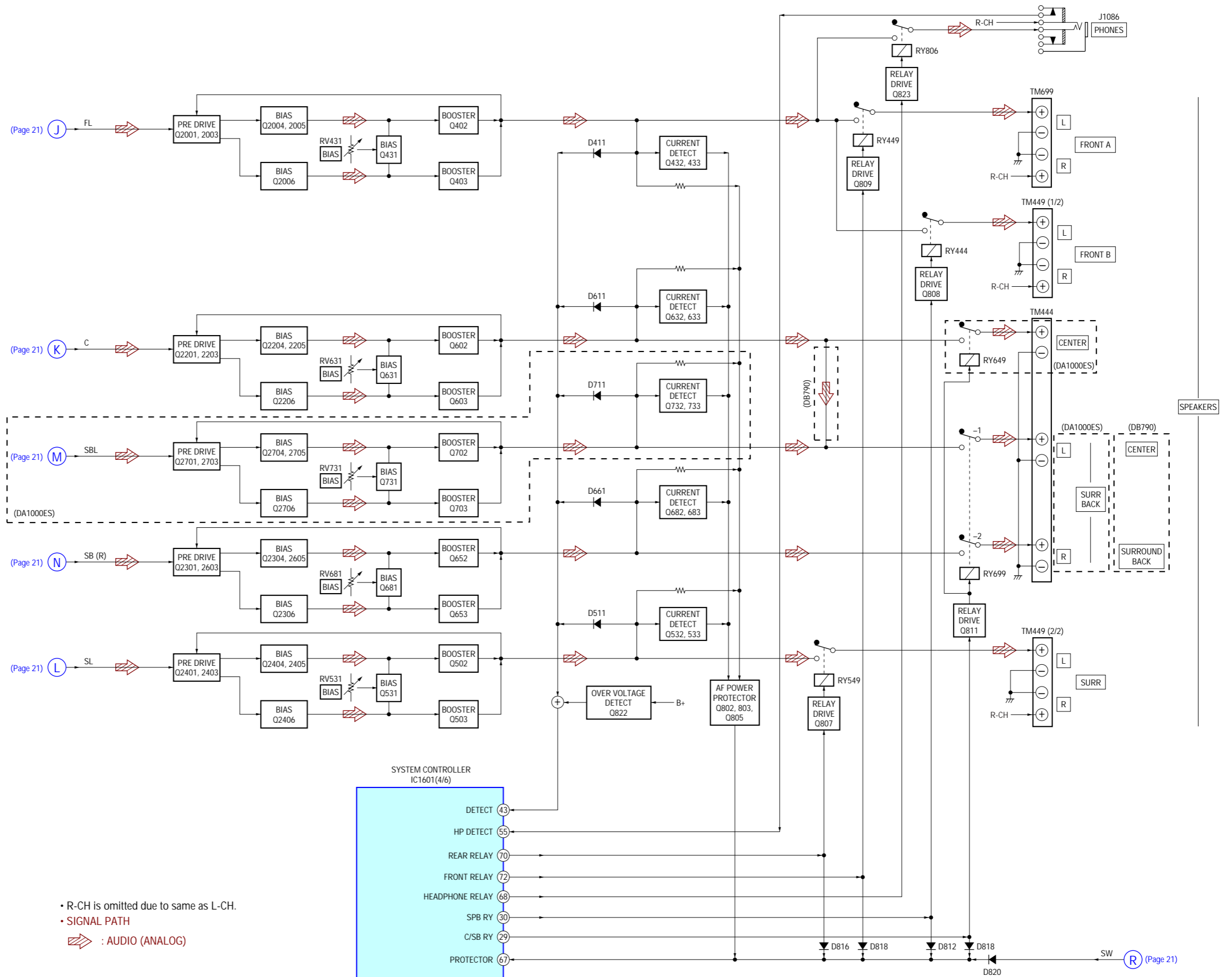

6-5. BLOCK DIAGRAM – DISPLAY/KEY CONTROL Section –

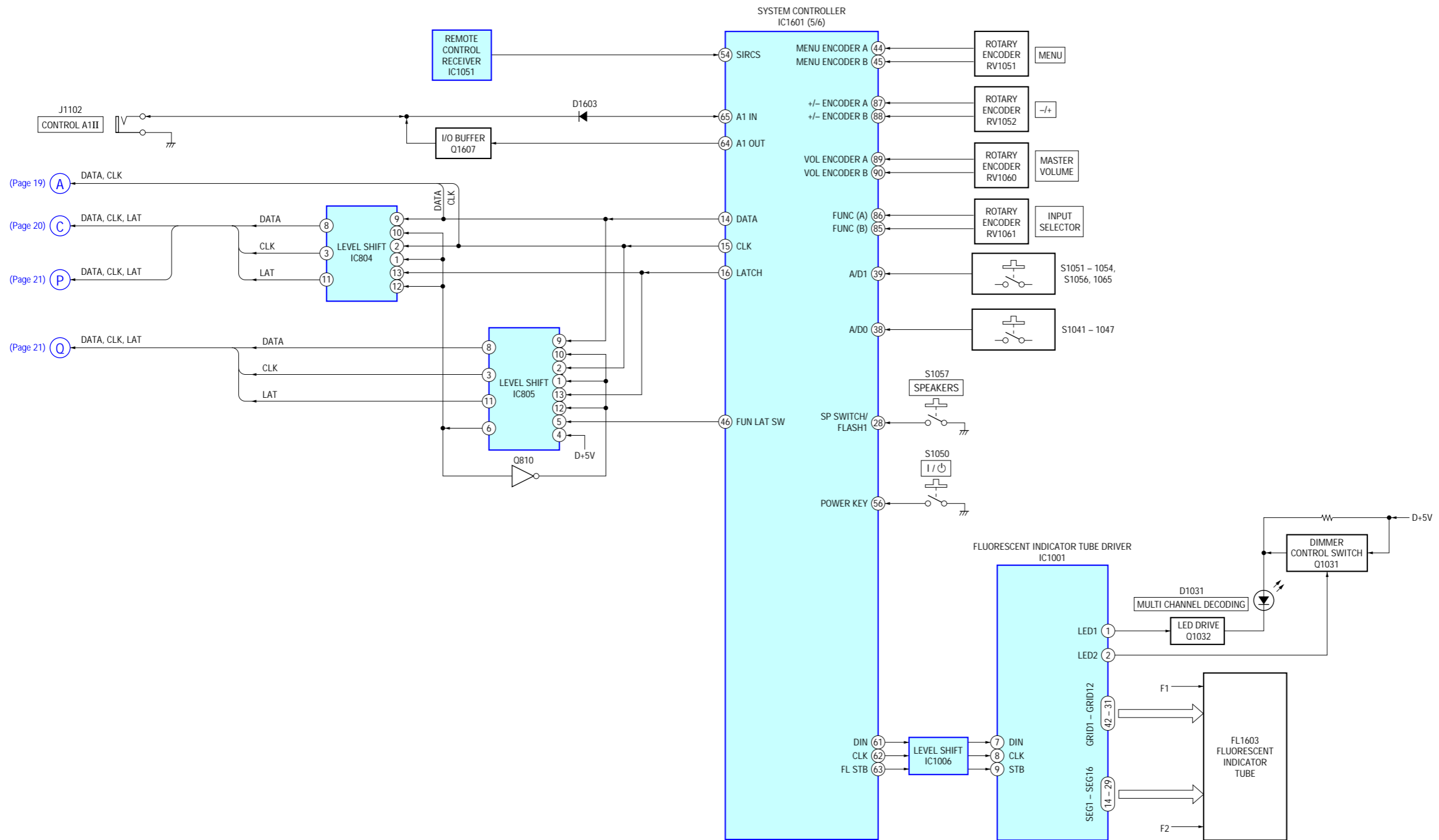

6-6. BLOCK DIAGRAM – POWER SUPPLY Section –

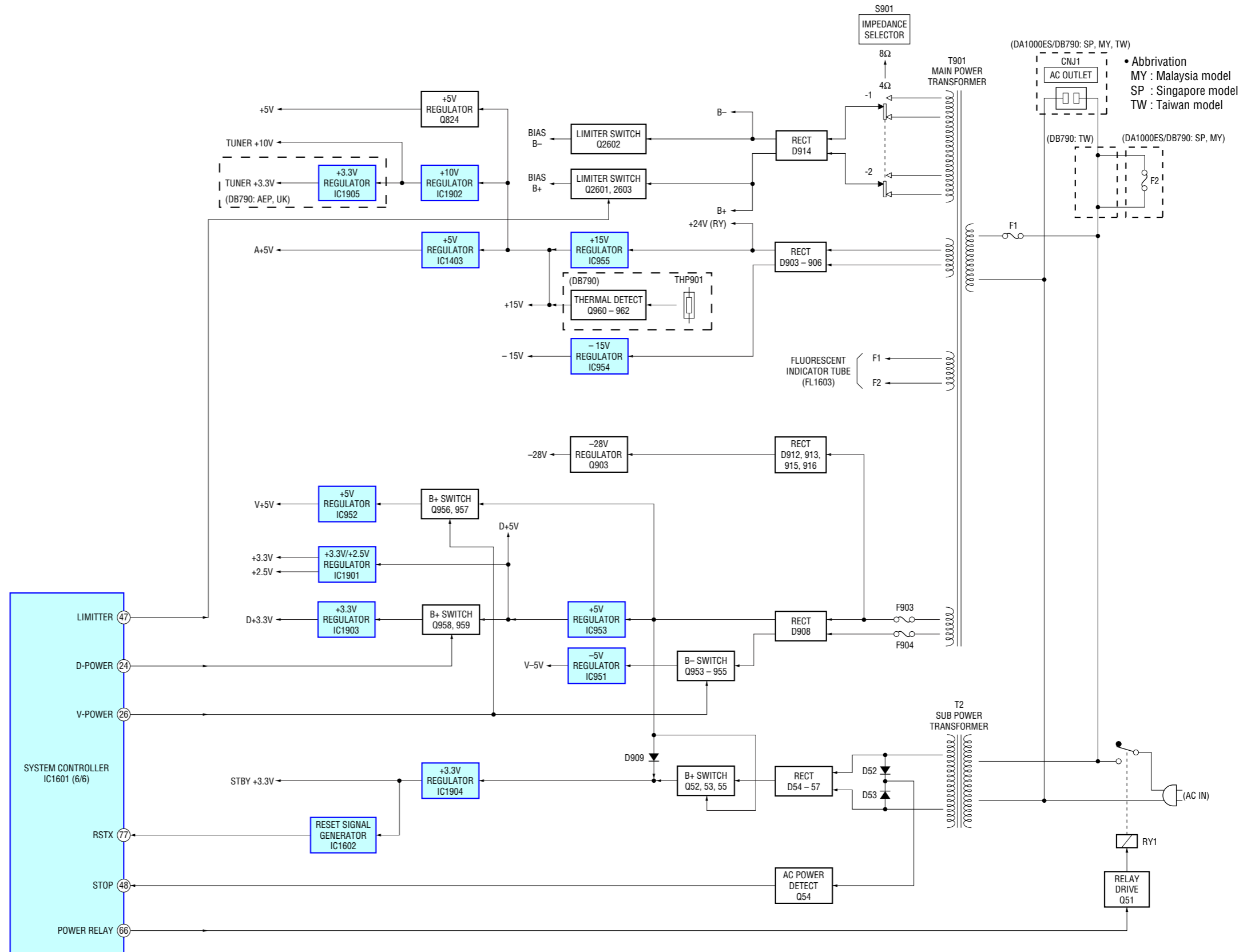

6-7. NOTE FOR PRINTED WIRING BOARDS AND SCHEMATIC DIAGRAMS

Note on Printed Wiring Board:

- : parts extracted from the component side.
- : parts extracted from the conductor side.
- : Pattern from the side which enables seeing.
(The other layers' patterns are not indicated.)

Caution:
 Pattern face side: Parts on the pattern face side seen from the pattern face are indicated.
 (Conductor Side)
 Parts face side: Parts on the parts face side seen from the parts face are indicated.
 (Component Side)

• Indication of transistor

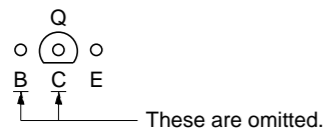
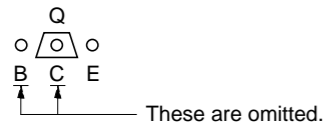
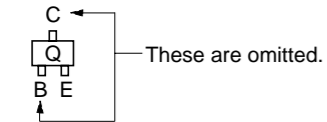

Note on Schematic Diagram:

- All capacitors are in μF unless otherwise noted. pF: $\mu\mu\text{F}$ 50 WV or less are not indicated except for electrolytics and tantalums.
- All resistors are in Ω and $\frac{1}{4}W$ or less unless otherwise specified.
- : nonflammable resistor.
- : panel designation.

Note:

The components identified by mark Δ or dotted line with mark Δ are critical for safety. Replace only with part number specified.

Note:

Les composants identifiés par une marque Δ sont critiques pour la sécurité. Ne les remplacer que par une pièce portant le numéro spécifié.

以阴影和 Δ 标志来识别的零部件在安全方面具有关键性。因此只能以规定号码的零部件来更换。

- : B+ Line.
- - - : B- Line.
- : adjustment for repair.
- Voltages and waveforms are dc with respect to ground under no-signal (detuned) conditions.
- no mark : TUNER
- () : VIDEO 1
- Voltages are taken with a VOM (Input impedance $10\text{M}\Omega$). Voltage variations may be noted due to normal production tolerances.
- Waveforms are taken with a oscilloscope. Voltage variations may be noted due to normal production tolerances.
- Circled numbers refer to waveforms.
- Signal path.
- ⇒ : TUNER
- ⇒ : AUDIO (ANALOG)
- ⇒ : AUDIO (DIGITAL)
- ⇒ : VIDEO
- Abbreviation
- AUS : Australian model
- CH : Chinese model
- KR : Korean model
- MY : Malaysia model
- SP : Singapore model
- TW : Taiwan model

• Circuit Boards Location

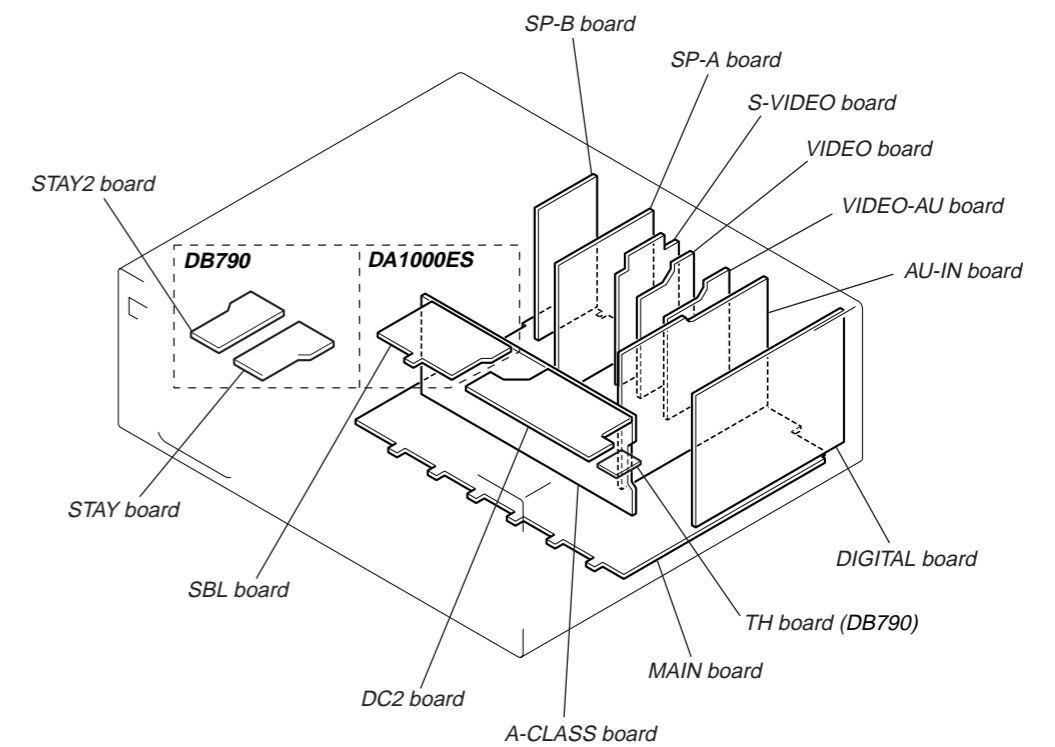
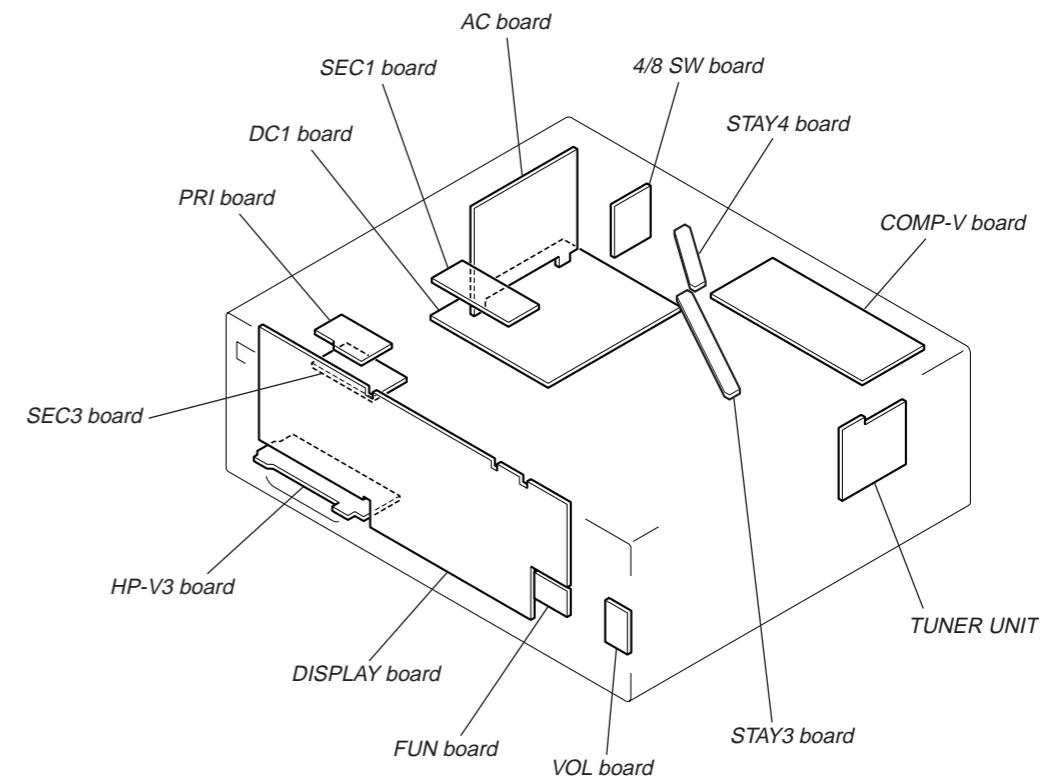

• Semiconductor Location

Ref. No.	Location
D1001	J-2
D1101	H-3
D1601	H-11
D1603	E-10
D1905	D-9
D1906	D-9
D1907	D-8
IC1101	F-3
IC1102	K-2
IC1103	E-3
IC1201	H-6
IC1202	F-6
IC1204	H-8
IC1401	I-10
IC1402	K-10
IC1501	I-3
IC1502	I-4
IC1503	H-2
IC1504	H-4
IC1521	J-8
IC1541	J-7
IC1561	J-5
IC1581	J-4
IC1601	G-10
IC1602	D-12
IC1604	G-11
Q1601	H-11
Q1602	H-11
Q1603	H-11
Q1607	E-10

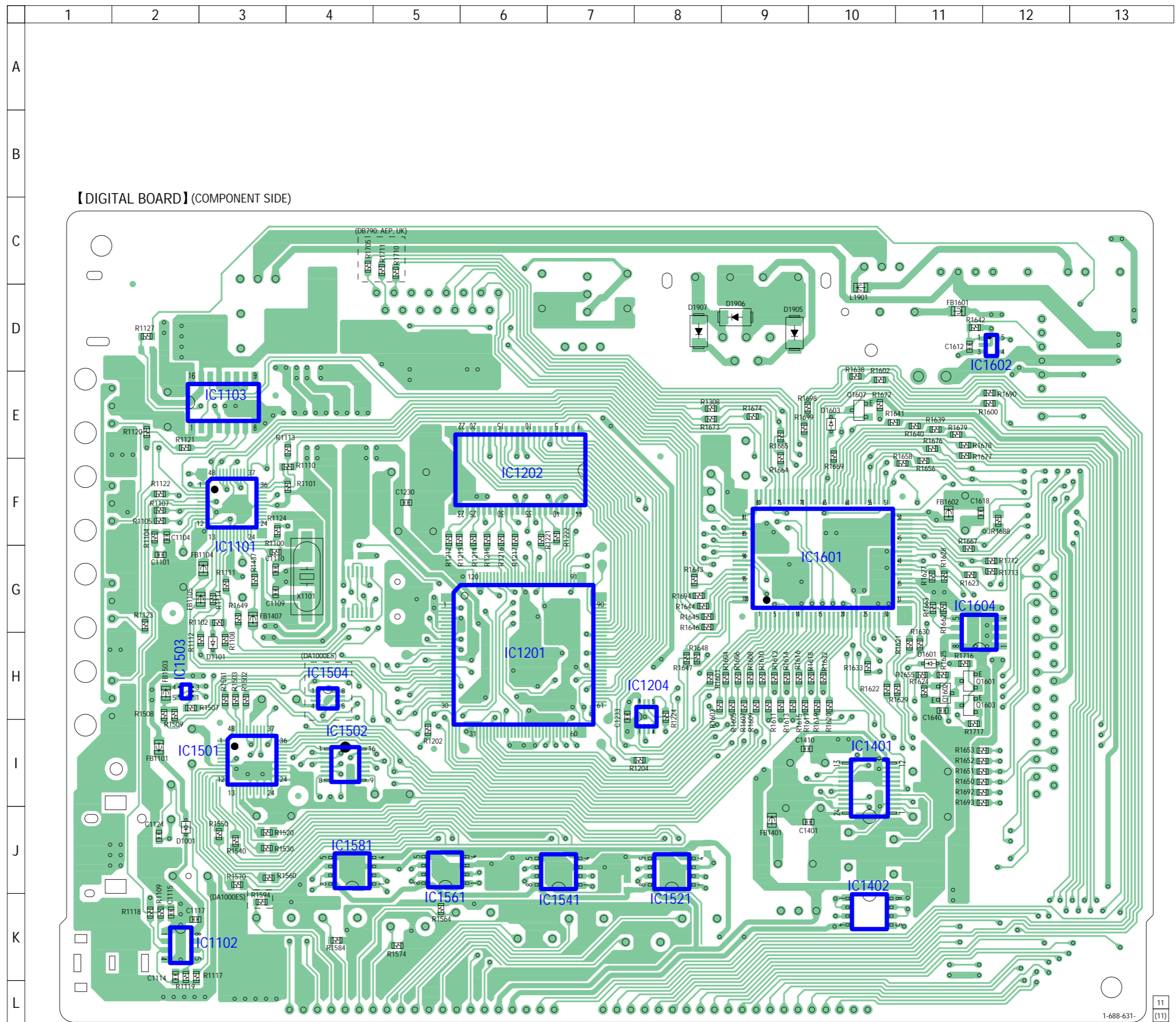

6-9. PRINTED WIRING BOARD – DIGITAL Board (Conductor Side) – • See page 25 for Circuit Boards Location.  :Uses unleaded solder.

• Semiconductor Location

Ref. No.	Location
IC1104	E-13
IC1105	F-13
IC1106	G-13
IC1107	H-13
IC1403	K-5
IC1901	D-6
IC1902	D-8
IC1903	C-12
IC1904	C-4
IC1905	D-8

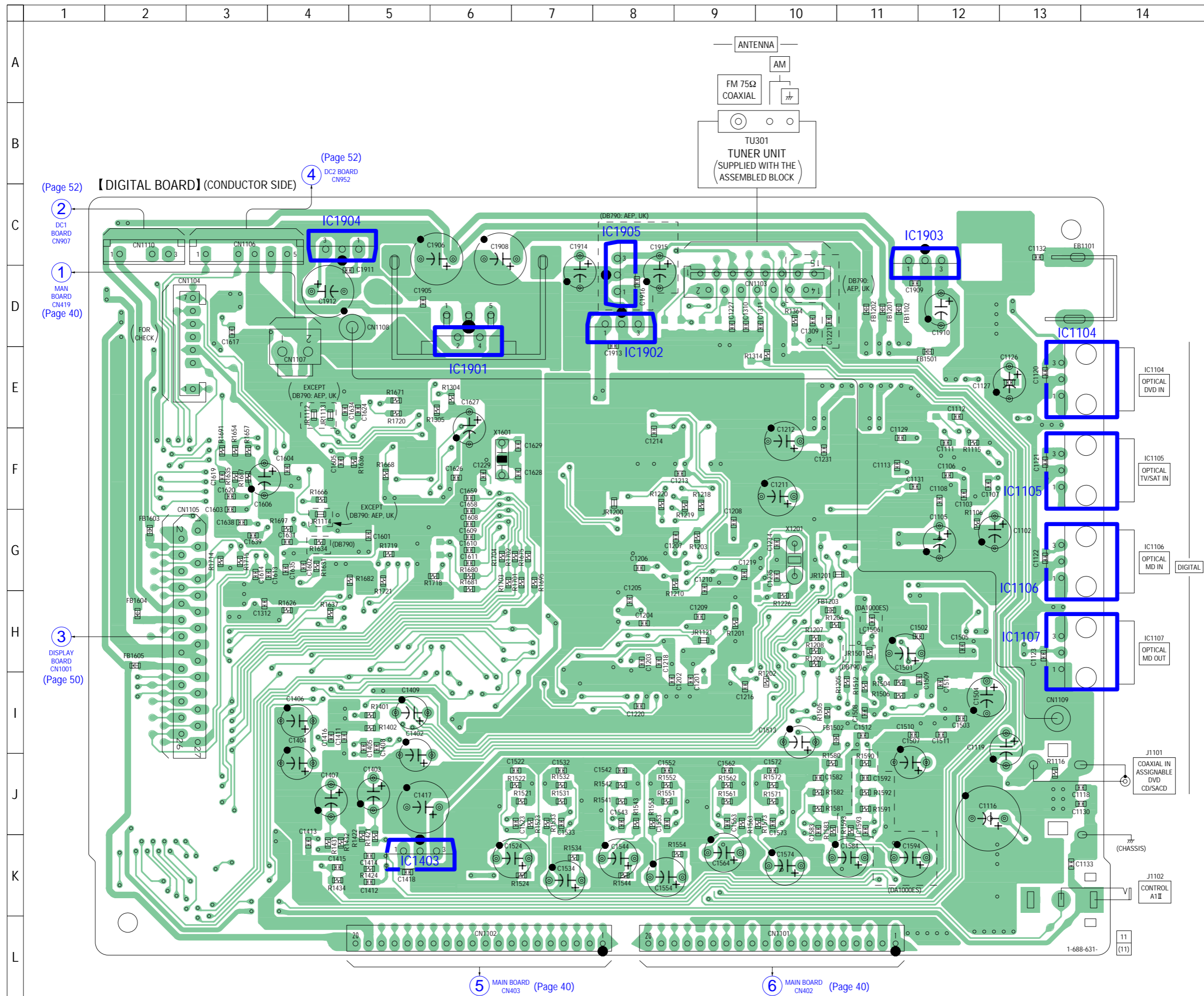

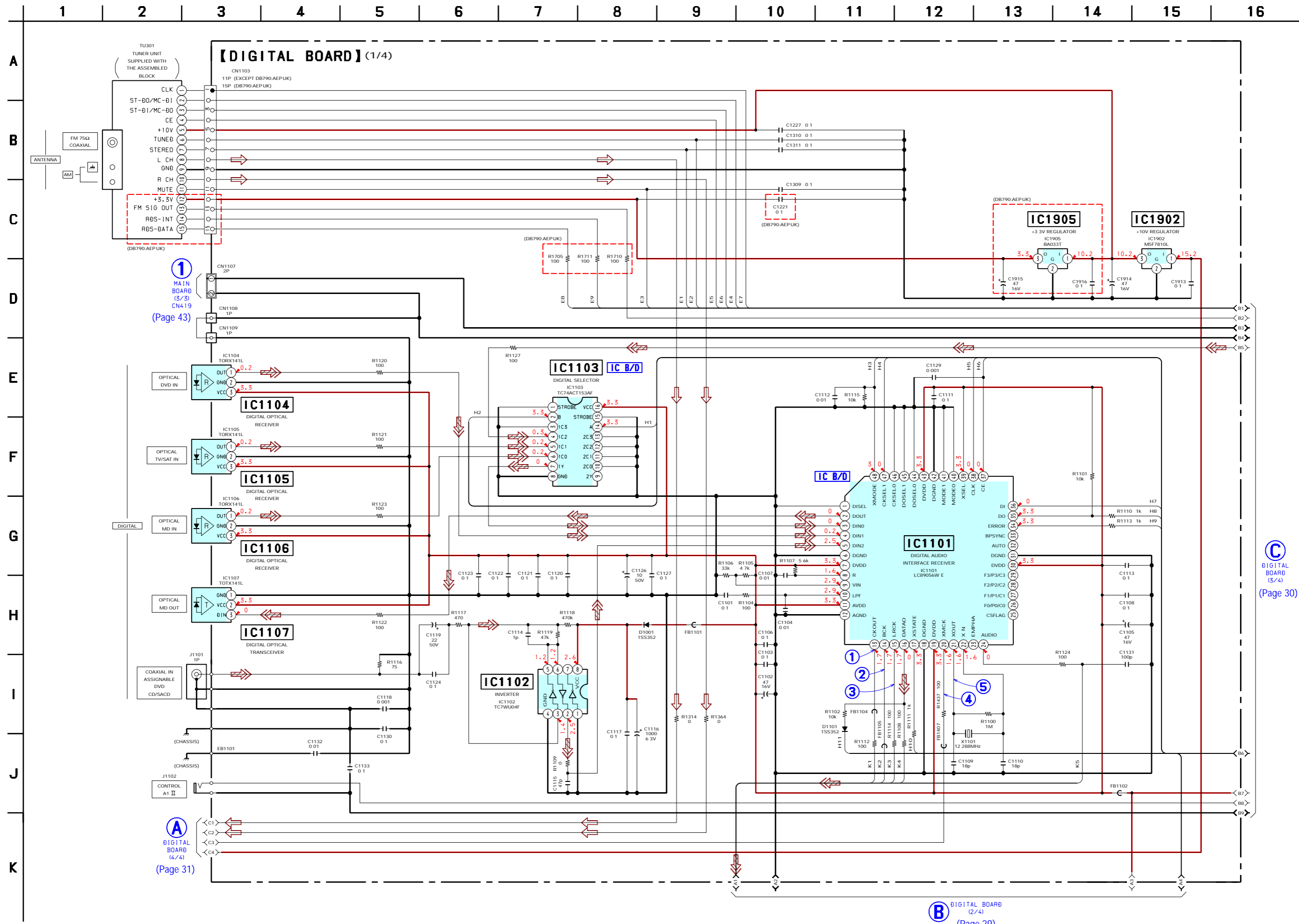

1 MAIN BOARD (3/3) CN419 (Page 43)

C DIGITAL BOARD (3/4) (Page 30)

A DIGITAL BOARD (4/4) (Page 31)

B DIGITAL BOARD (2/4) (Page 29)

6-11. SCHEMATIC DIAGRAM – DIGITAL Board (2/4) – • See page 56 for Waveforms. • See page 57 for IC Block Diagram.

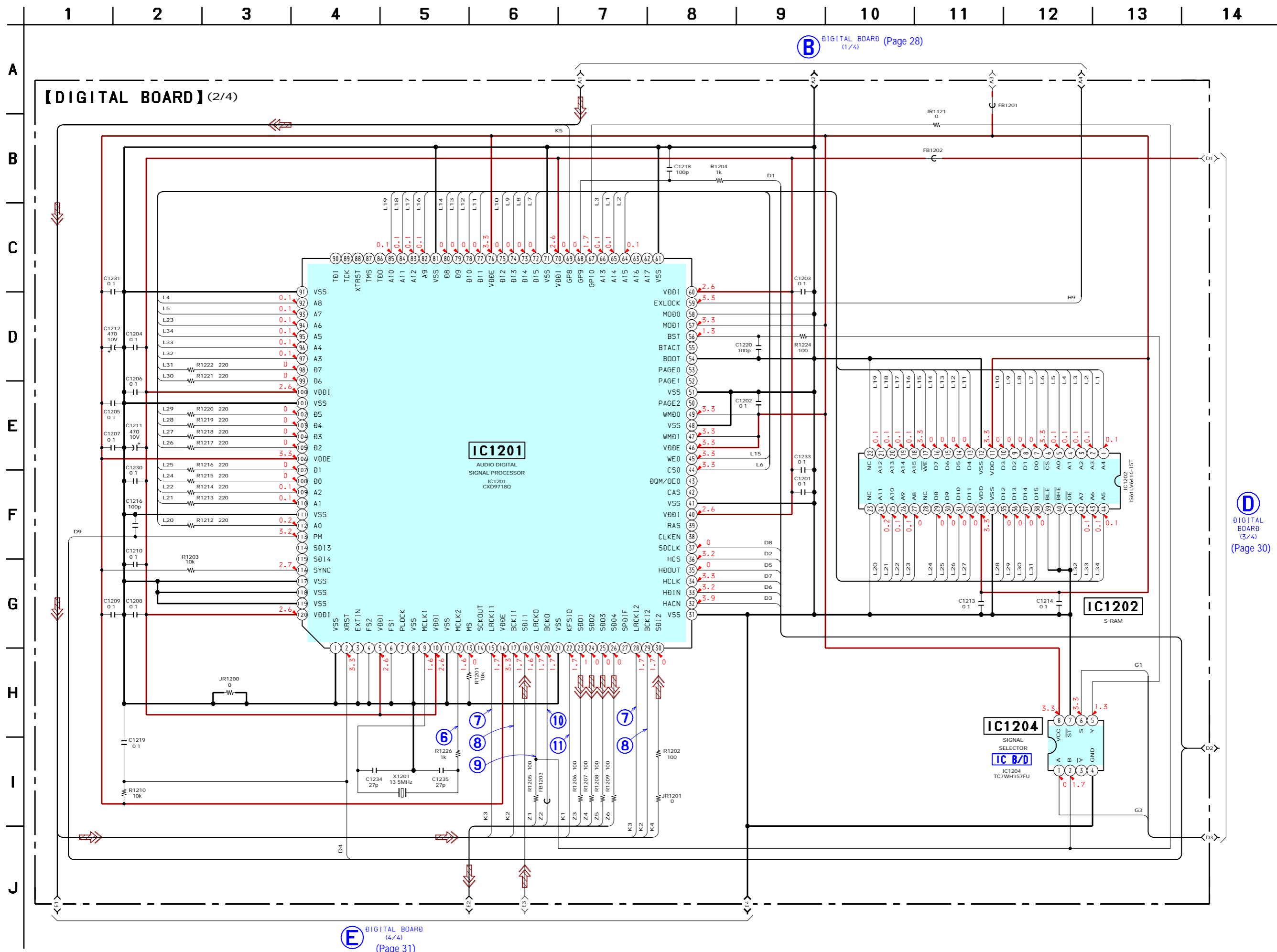

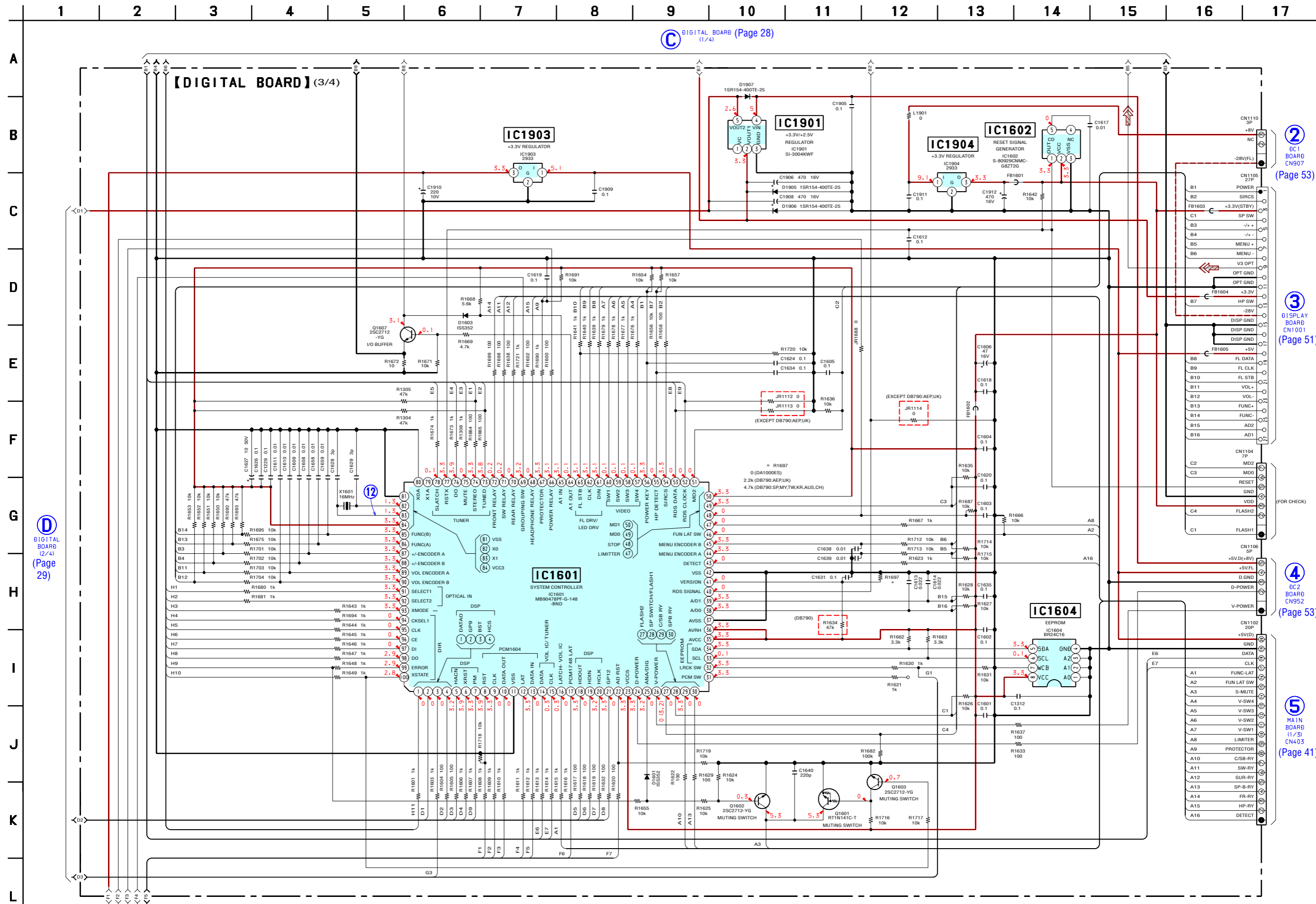

DIGITAL BOARD (Page 28) (1/4)

BC1 BOARD CN907 (Page 53)

DISPLAY BOARD CN1001 (Page 51)

BC2 BOARD CN952 (Page 53)

MAIN BOARD (1/3) CN403 (Page 51)

DIGITAL BOARD (2/4) (Page 29)

DIGITAL BOARD (4/4) (Page 31)

6-13. SCHEMATIC DIAGRAM – DIGITAL Board (4/4) – • See page 56 for Waveforms. • See page 57 for IC Block Diagrams.

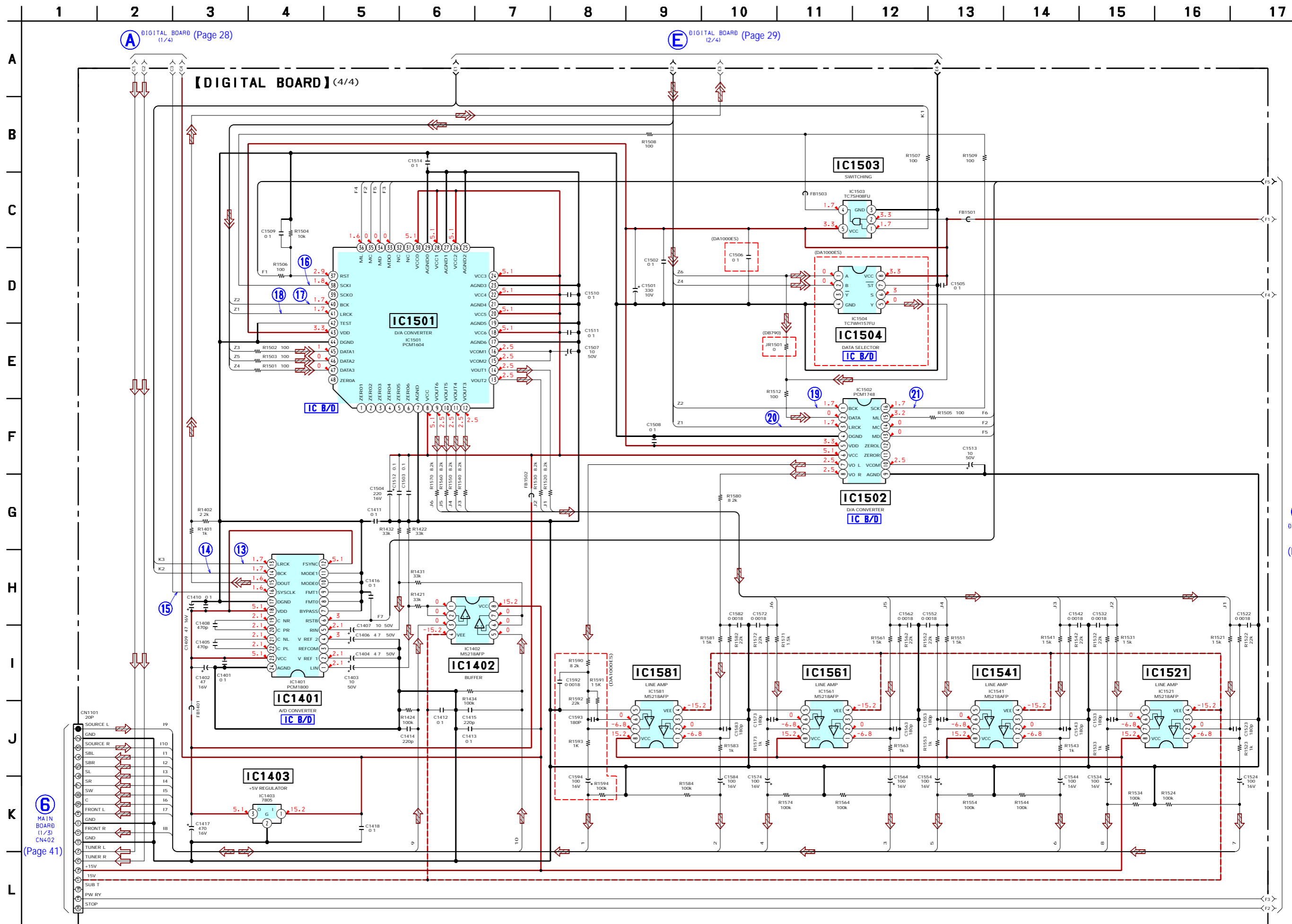

DIGITAL BOARD (3/4) (Page 30)

6-14. PRINTED WIRING BOARDS – VIDEO/VIDEO-AU Boards – • See page 25 for Circuit Boards Location.  :Uses unleaded solder.

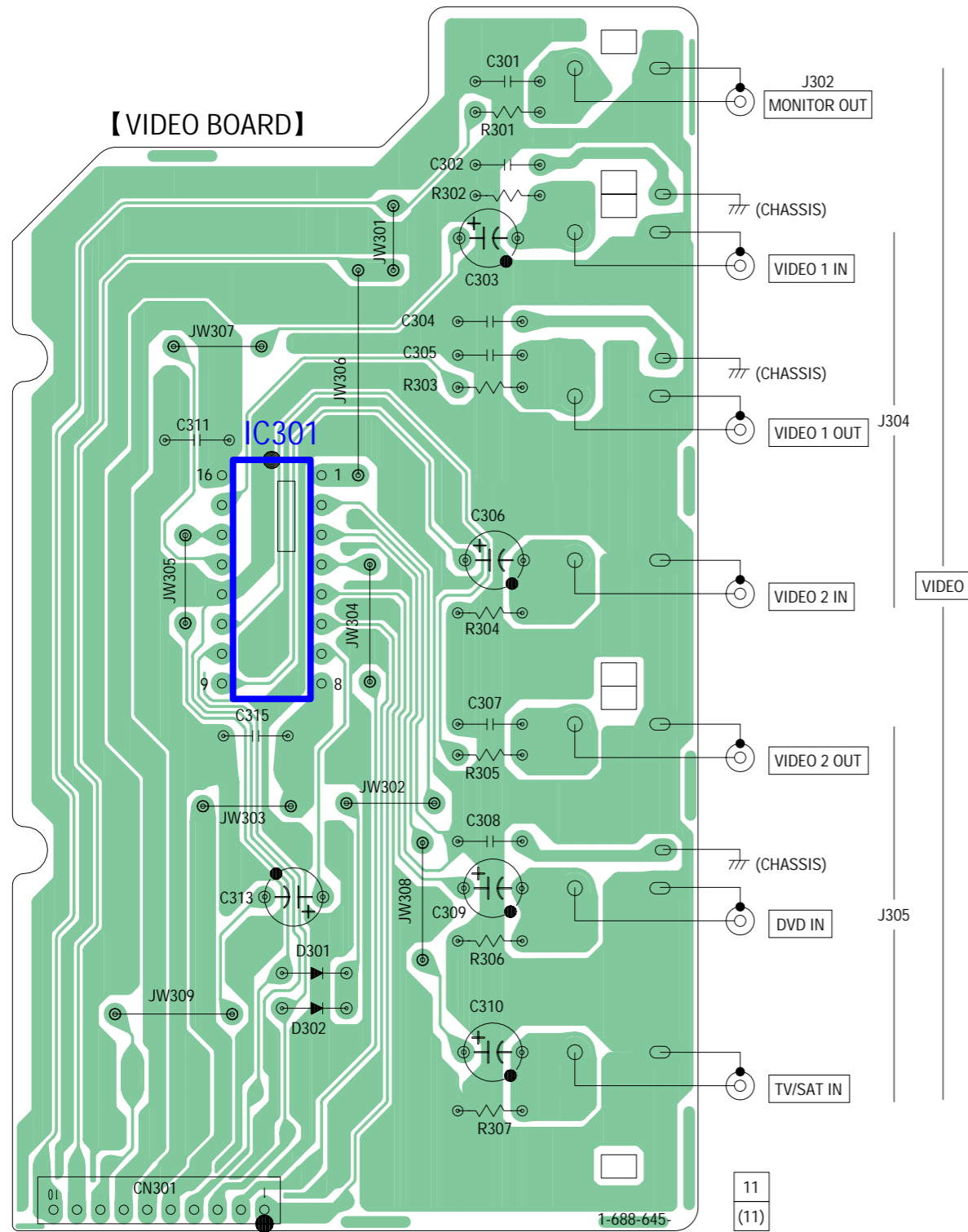

7 MAIN BOARD
CN407
(Page 40)

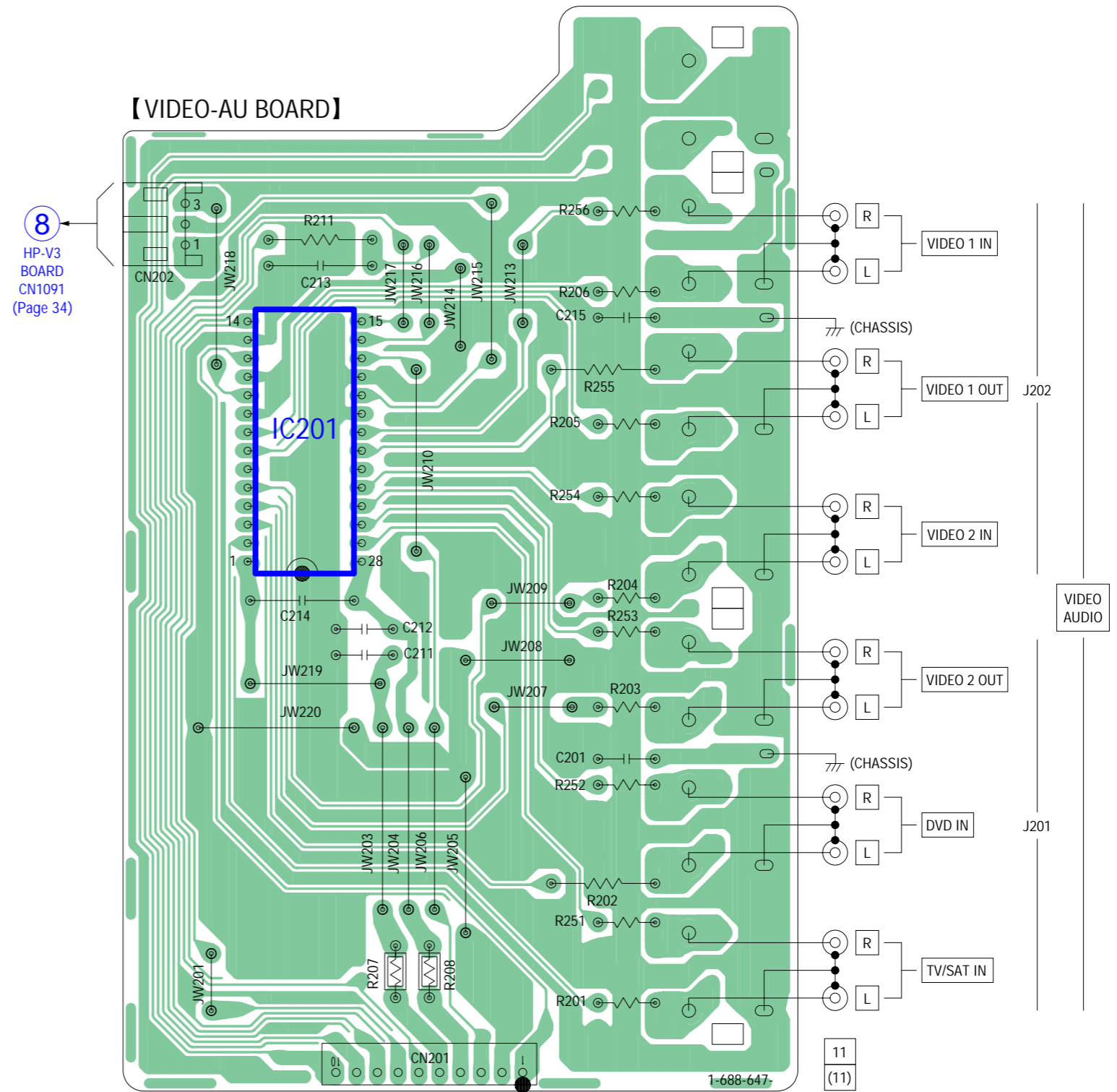

8 HP-V3 BOARD
CN1091
(Page 34)

9 MAIN BOARD
CN406
(Page 40)

6-15. SCHEMATIC DIAGRAM – VIDEO/VIDEO-AU Boards – • See page 57 for IC Block Diagrams.

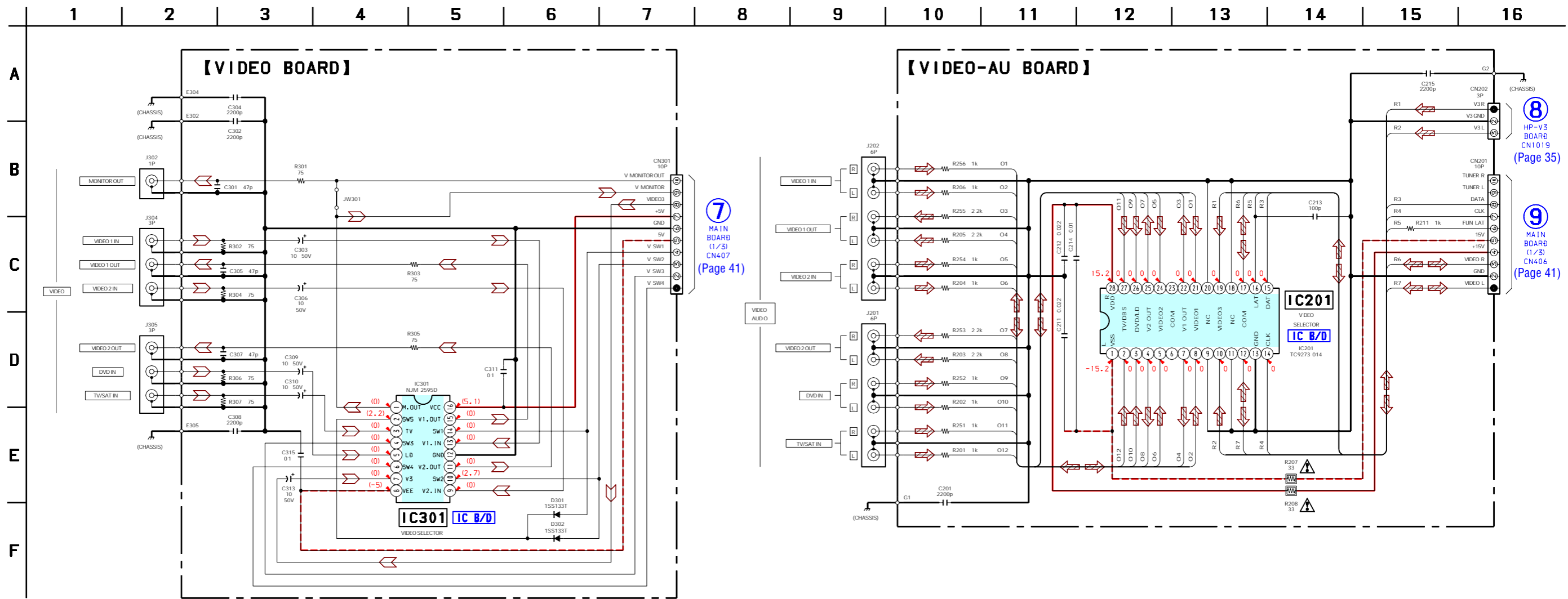

The components identified by mark \triangle or dotted line with mark \triangle are critical for safety. Replace only with part number specified.

Les composants identifiés par une marque \triangle sont critiques pour la sécurité. Ne les remplacer que par une pièce portant le numéro spécifié.

以阴影和 \triangle 标志来识别的零部件在安全方面具有关键性。因此只能以规定号码的零部件来更换。

16-16. PRINTED WIRING BOARDS – HP-V3/S-VIDEO Boards – • See page 25 for Circuit Boards Location.  :Uses unleaded solder.

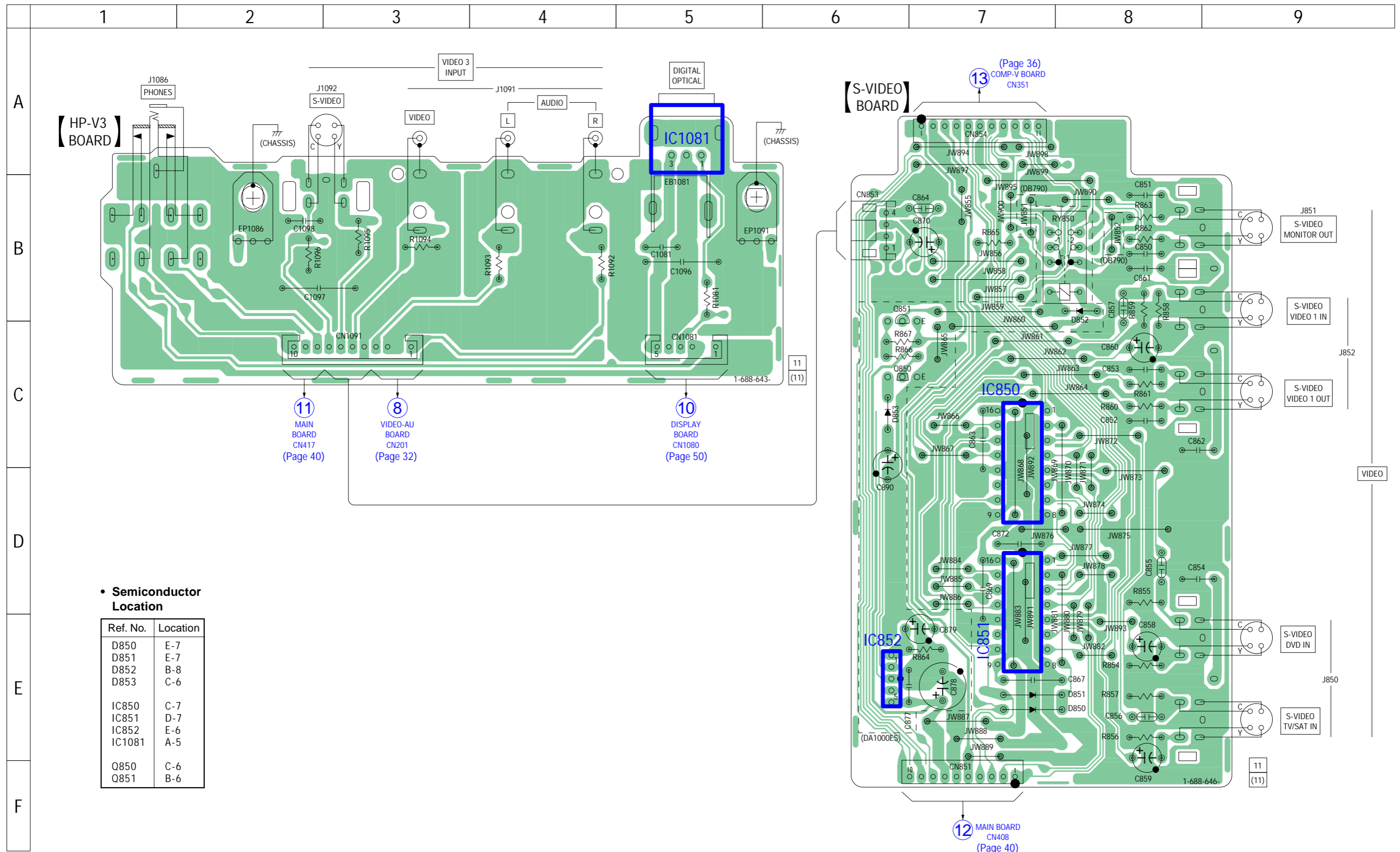

• Semiconductor Location

Ref. No.	Location
D850	E-7
D851	E-7
D852	B-8
D853	C-6
IC850	C-7
IC851	D-7
IC852	E-6
IC1081	A-5
Q850	C-6
Q851	B-6

6-17. SCHEMATIC DIAGRAM – HP-V3/S-VIDEO Boards – • See page 57 for IC Block Diagrams.

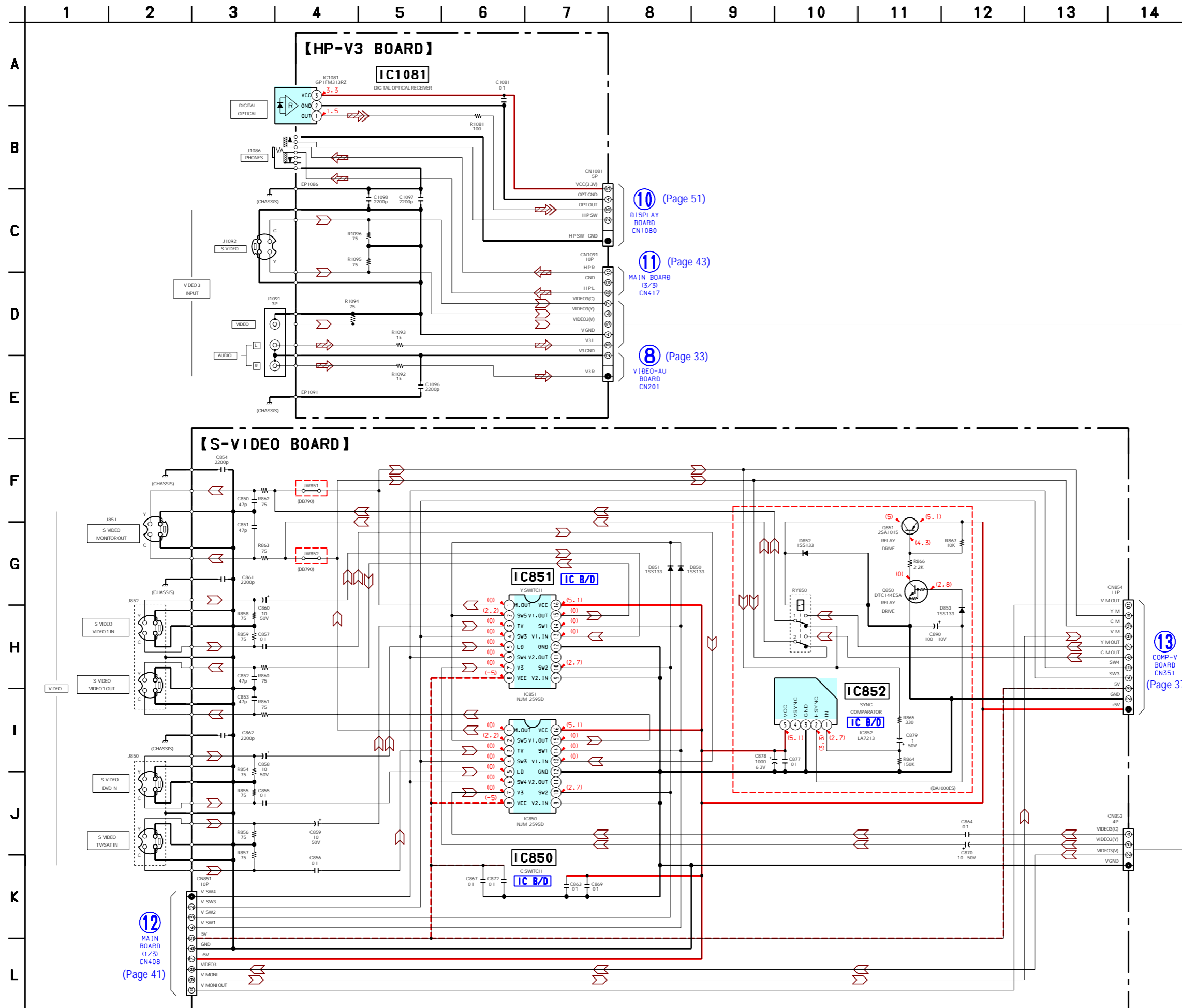

10 (Page 51)
DISPLAY BOARD
CN1080

11 (Page 43)
MAIN BOARD
(3/3)
CN417

8 (Page 33)
VIDEO-AU BOARD
CN201

13 (Page 37)
COMP-V BOARD
CN351

12 (Page 41)
MAIN BOARD
(1/3)
CN408

6-18. PRINTED WIRING BOARD – COMP-V Board – • See page 25 for Circuit Boards Location.  :Uses unleaded solder.

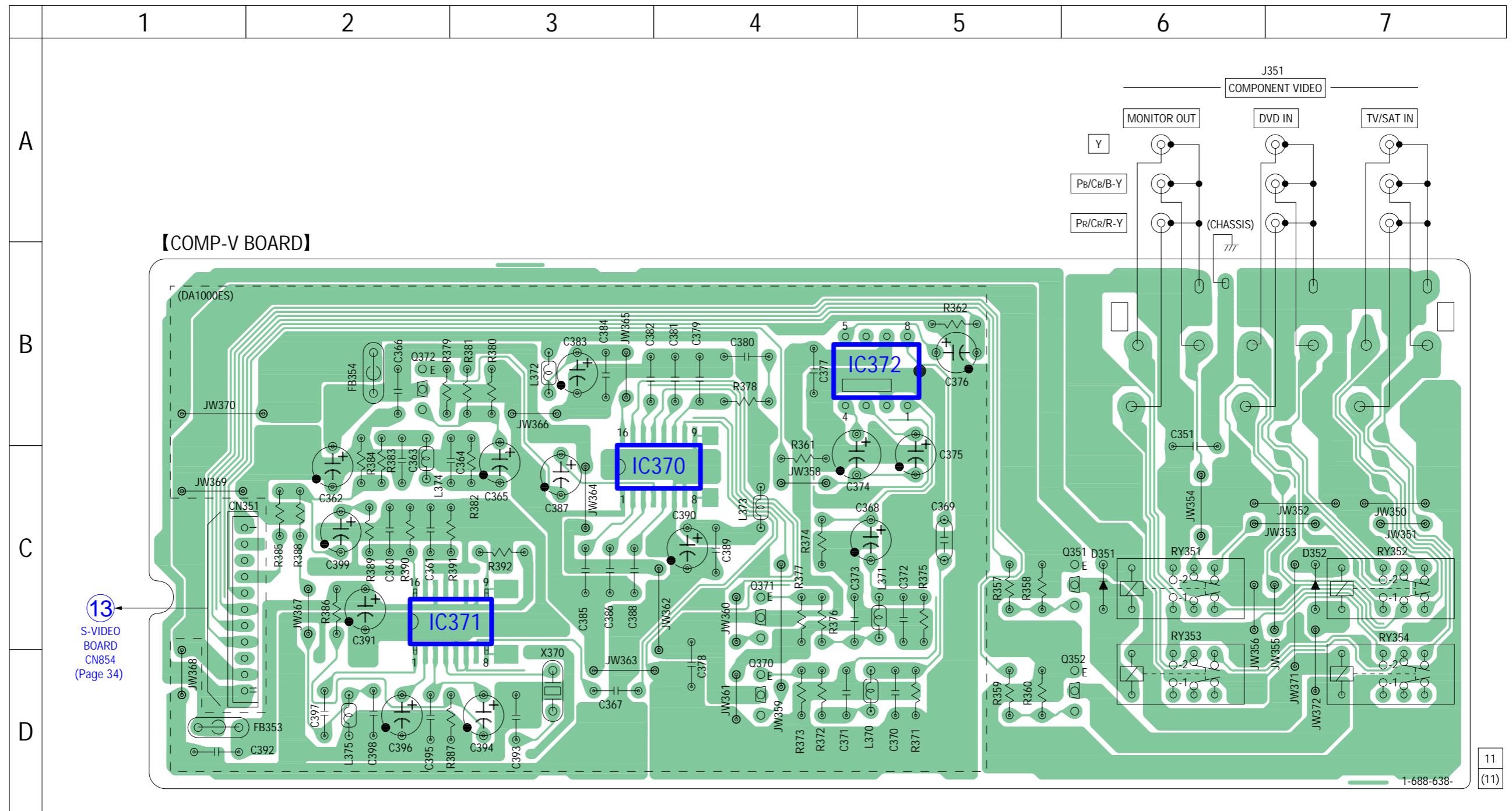

• Semiconductor Location

Ref. No.	Location
D351	C-6
D352	C-7
IC370	C-4
IC371	C-3
IC372	B-5
Q351	C-6
Q352	D-6
Q370	D-4
Q371	C-4
Q372	B-2

6-19. SCHEMATIC DIAGRAM – COMP-V Board – • See page 56 for Waveform. • See page 57 for IC Block Diagrams.

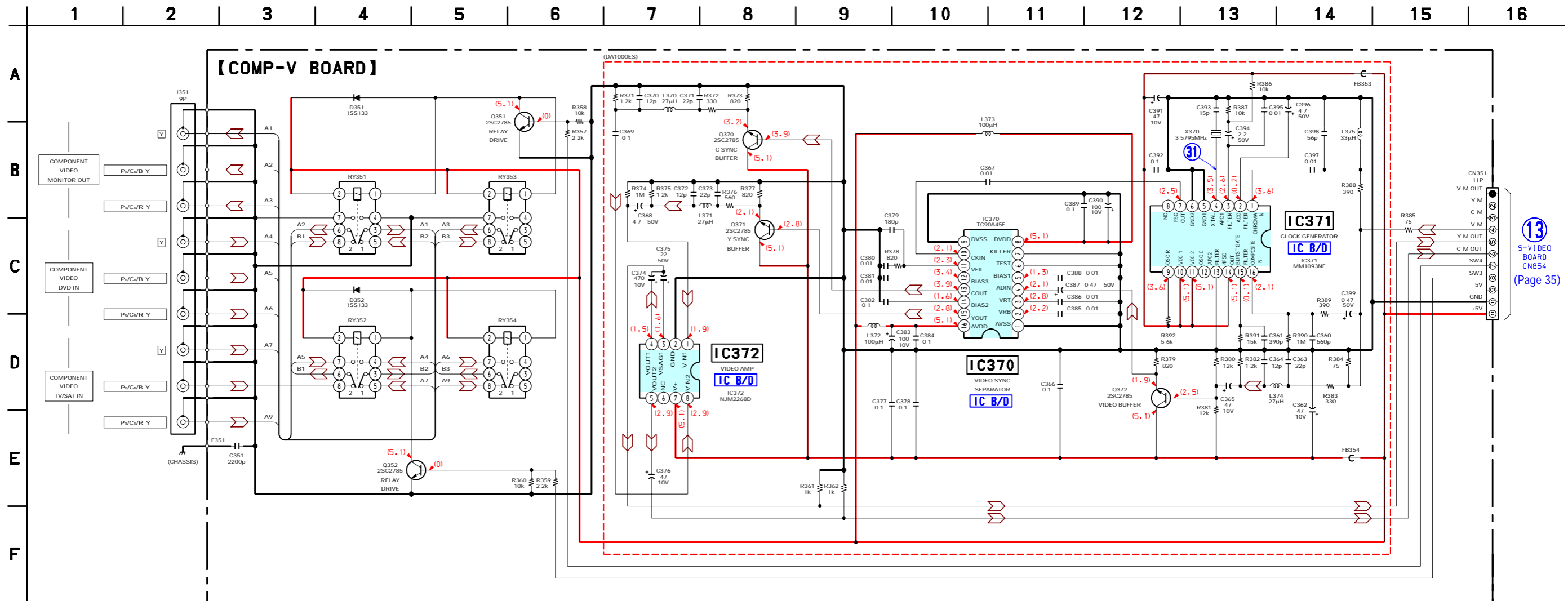

13
5-VIDEO BOARD
CN854
(Page 35)

6-20. PRINTED WIRING BOARD – AU-IN Board – • See page 25 for Circuit Boards Location.  :Uses unleaded solder.

• Semiconductor Location

Ref. No.	Location
IC101	D-4
IC110	B-4
IC111	B-3
IC112	B-2
IC131	B-5
IC171	E-2
IC172	B-1
IC173	C-2

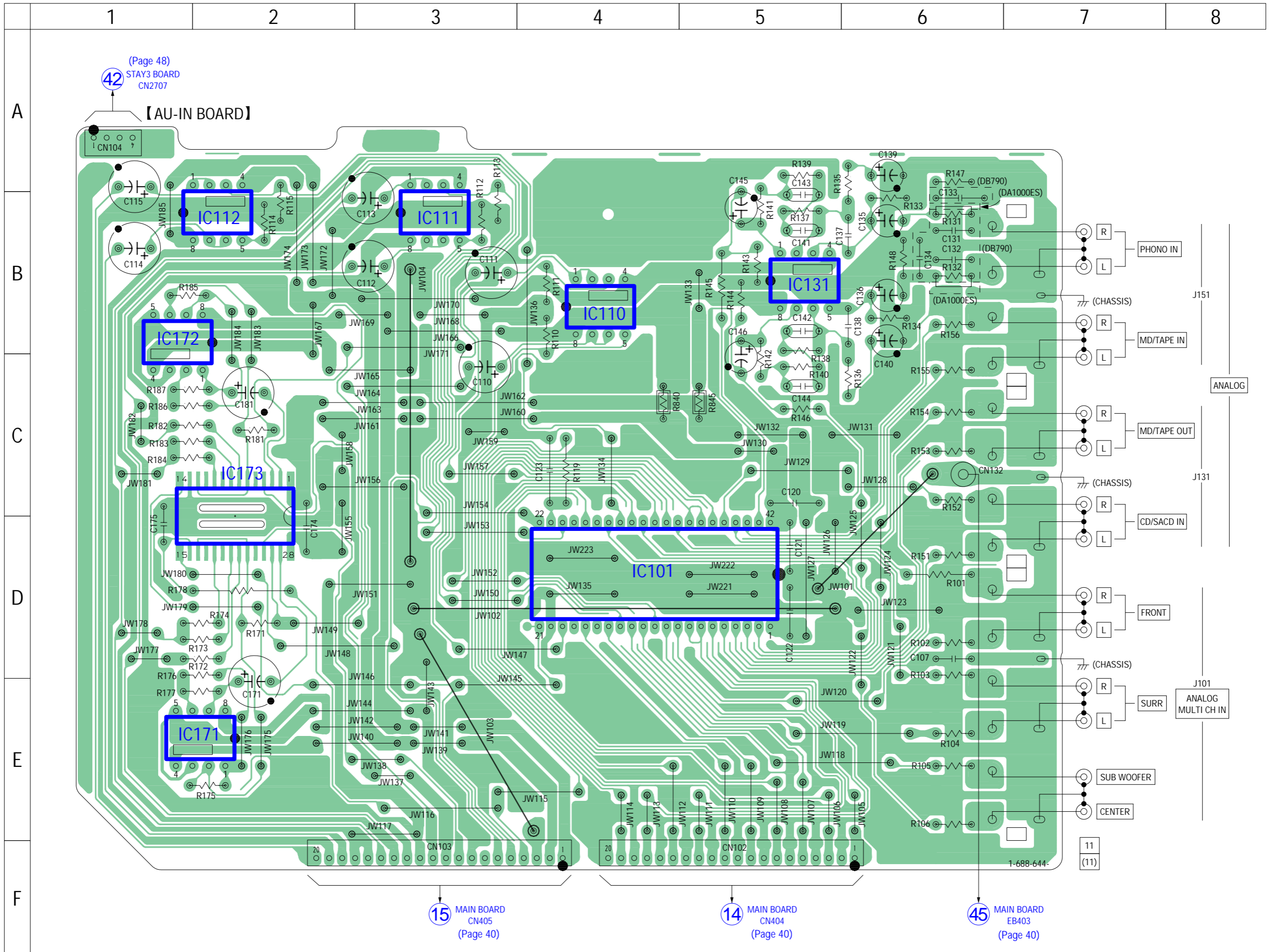

6-21. SCHEMATIC DIAGRAM – AU-IN Board – • See page 57 for IC Block Diagrams.

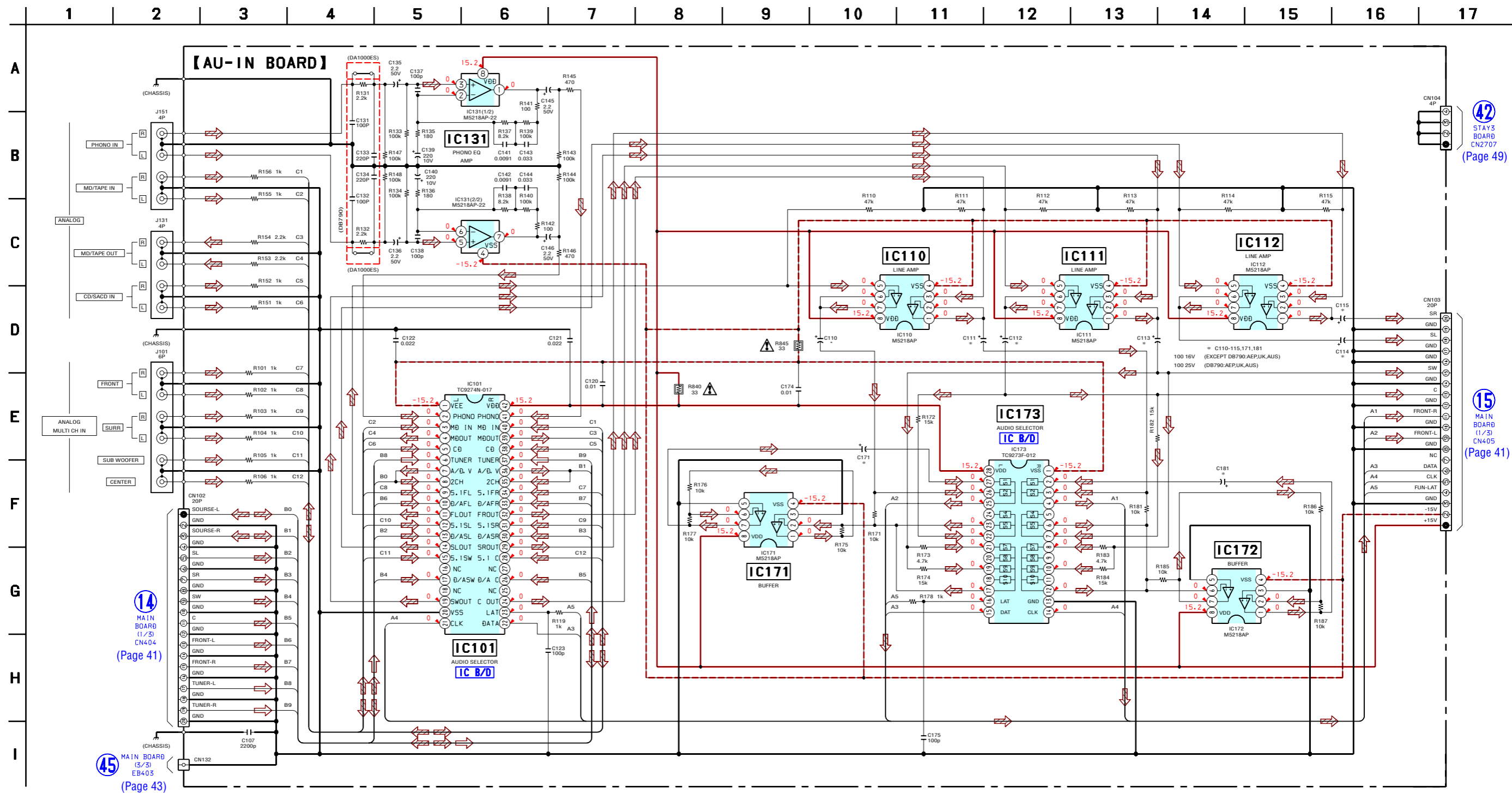

The components identified by mark ▲ or dotted line with mark ▲ are critical for safety. Replace only with part number specified.

Les composants identifiés par une marque ▲ sont critiques pour la sécurité. Ne les remplacer que par une pièce portant le numéro spécifié.

以阴影和▲标志来识别的零部件在安全方面具有关键性。因此只能以规定号码的零部件来更换。

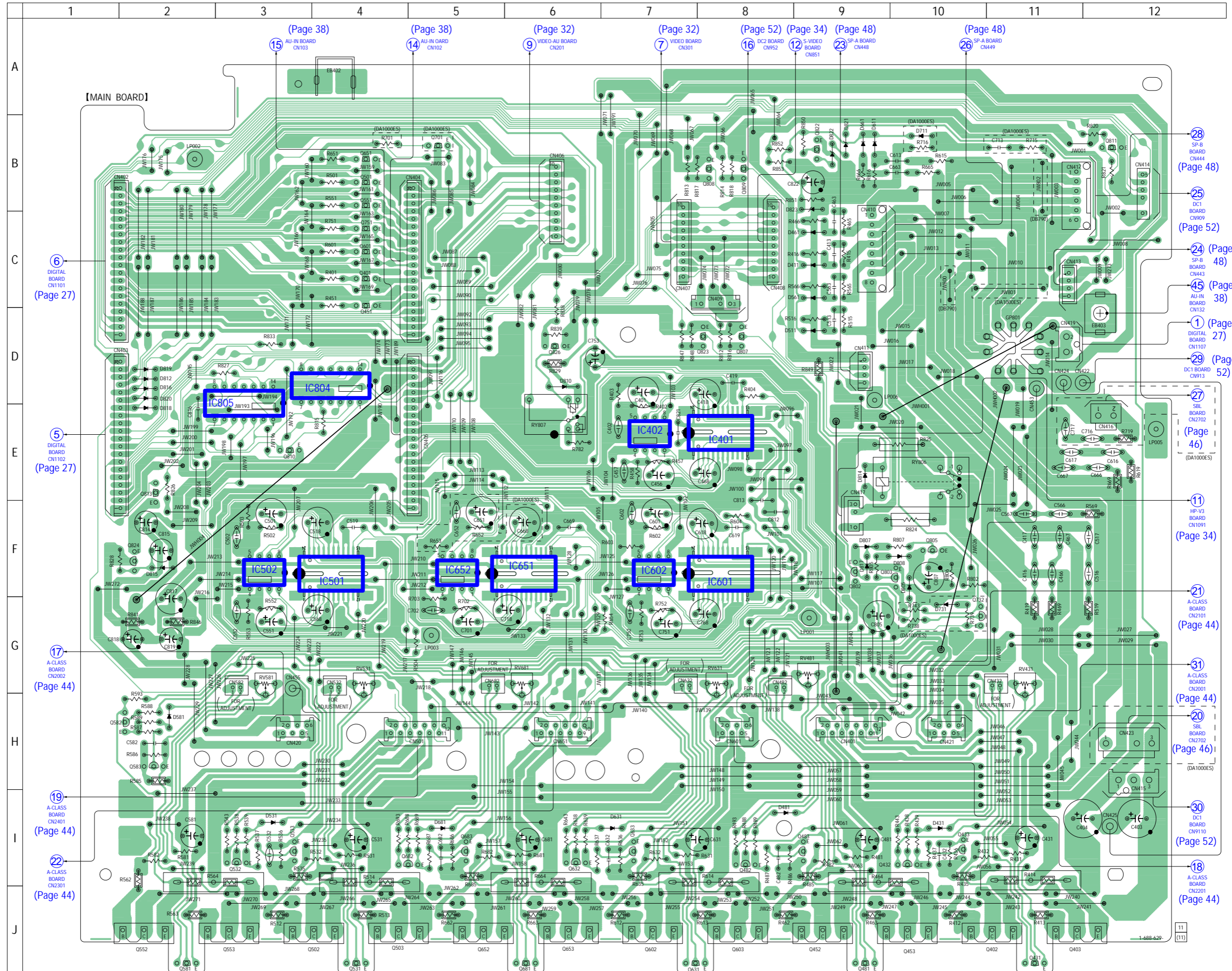

6-23. SCHEMATIC DIAGRAM – MAIN Board (1/3) – • See page 57 for IC Block Diagram.

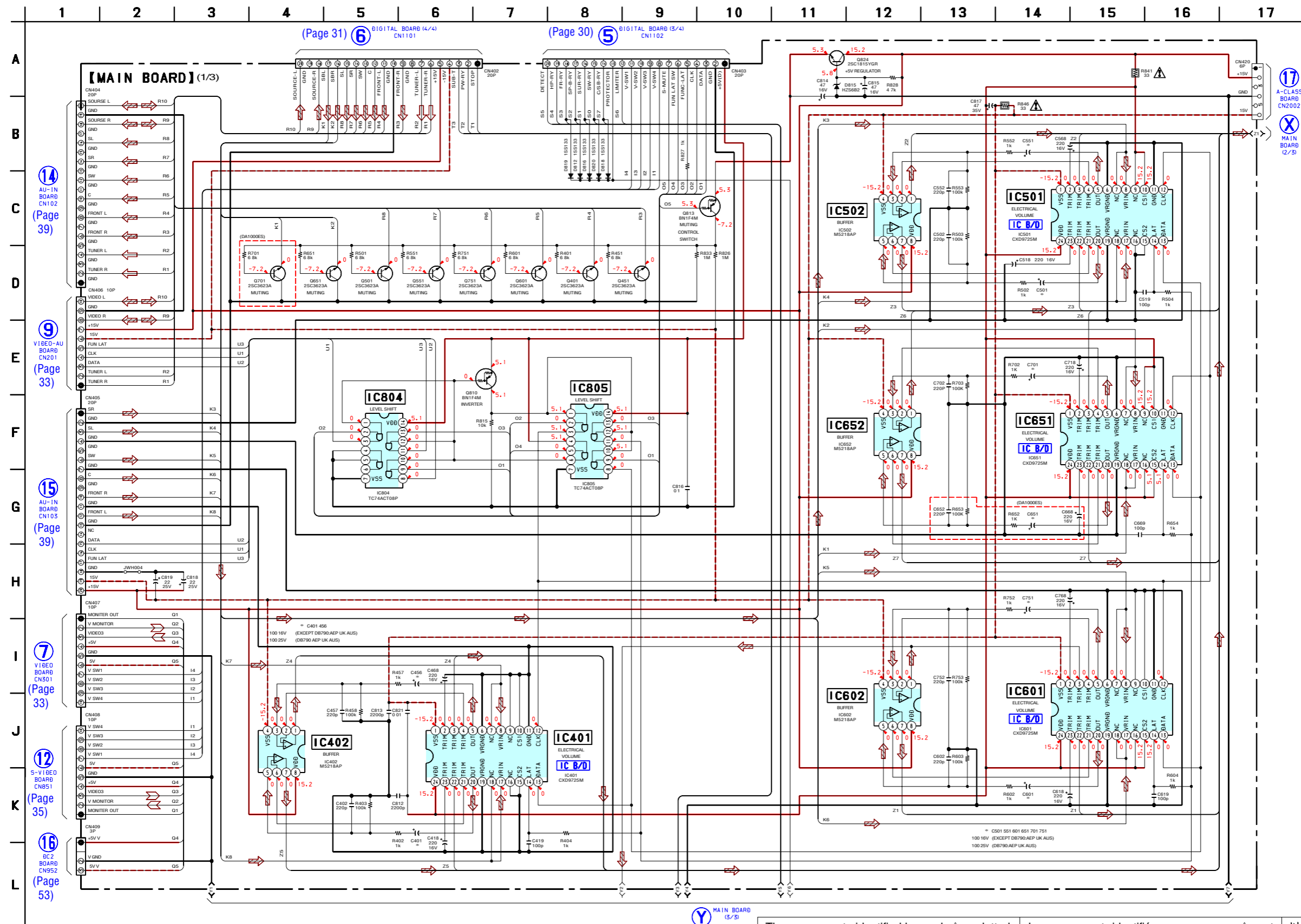

17 (Page 45)
 A-CLASS BOARD CN2002
 X (Page 42)
 MAIN BOARD (2/3)

14 (Page 39)
 AU-IN BOARD CN102

9 (Page 33)
 VIDEO-AU BOARD CN201

15 (Page 39)
 AU-IN BOARD CN103

7 (Page 33)
 VIDEO BOARD CN301

12 (Page 35)
 S-VIDEO BOARD CN851

16 (Page 53)
 IC2 BOARD CN952

Y MAIN BOARD (3/3)
 (Page 43)

The components identified by mark Δ or dotted line with mark Δ are critical for safety. Replace only with part number specified.

Les composants identifiés par une marque Δ sont critiques pour la sécurité. Ne les remplacer que par une pièce portant le numéro spécifié.

以阴影和 Δ 标志来识别的零部件在安全方面具有关键性。因此只能以规定号码的零部件来更换。

• Semiconductor Location

Ref. No.	Location	Ref. No.	Location	Ref. No.	Location	Ref. No.	Location	Ref. No.	Location	Ref. No.	Location	Ref. No.	Location	Ref. No.	Location	Ref. No.	Location	Ref. No.	Location	Ref. No.	Location		
D411	C-9	D611	B-9	D808	F-10	D819	D-2	IC501	F-4	Q401	C-4	Q452	J-9	Q531	J-4	Q583	H-2	Q652	J-5	Q802	F-9	Q813	E-2
D431	I-10	D631	I-7	D810	D-6	D820	D-2	IC502	F-3	Q402	J-11	Q453	J-10	Q532	I-3	Q601	C-4	Q653	J-6	Q803	F-10	Q822	B-9
D461	C-9	D661	B-9	D812	D-2	D821	B-9	IC601	F-8	Q403	J-11	Q481	J-9	Q533	I-3	Q602	J-7	Q681	J-6	Q805	F-10	Q823	D-8
D481	I-8	D681	I-5	D814	E-9	D822	B-9	IC602	E-7	Q404	J-11	Q482	I-8	Q551	B-4	Q603	J-8	Q682	I-5	Q807	D-8	Q824	F-2
D511	C-9	D711	B-10	D815	F-2	D823	B-9	IC651	F-6	Q431	J-11	Q483	I-9	Q552	J-2	Q631	J-7	Q683	I-5	Q808	B-8	Q826	D-6
D531	I-3	D731	G-10	D816	D-2			IC652	F-5	Q432	I-10	Q501	B-4	Q553	J-3	Q632	I-6	Q701	B-5	Q809	B-8		
D561	C-9	D805	F-10	D817	F-9	IC401	E-8	IC401	E-8	Q433	I-10	Q502	J-4	Q581	J-2	Q633	I-7	Q732	G-10	Q810	E-3		
D581	H-2	D807	F-9	D818	E-2	IC402	E-7	IC804	D-4	Q451	C-4	Q503	J-4	Q582	H-2	Q651	B-4	Q751	C-4	Q811	B-11		

6-24. SCHEMATIC DIAGRAM – MAIN Board (2/3) –

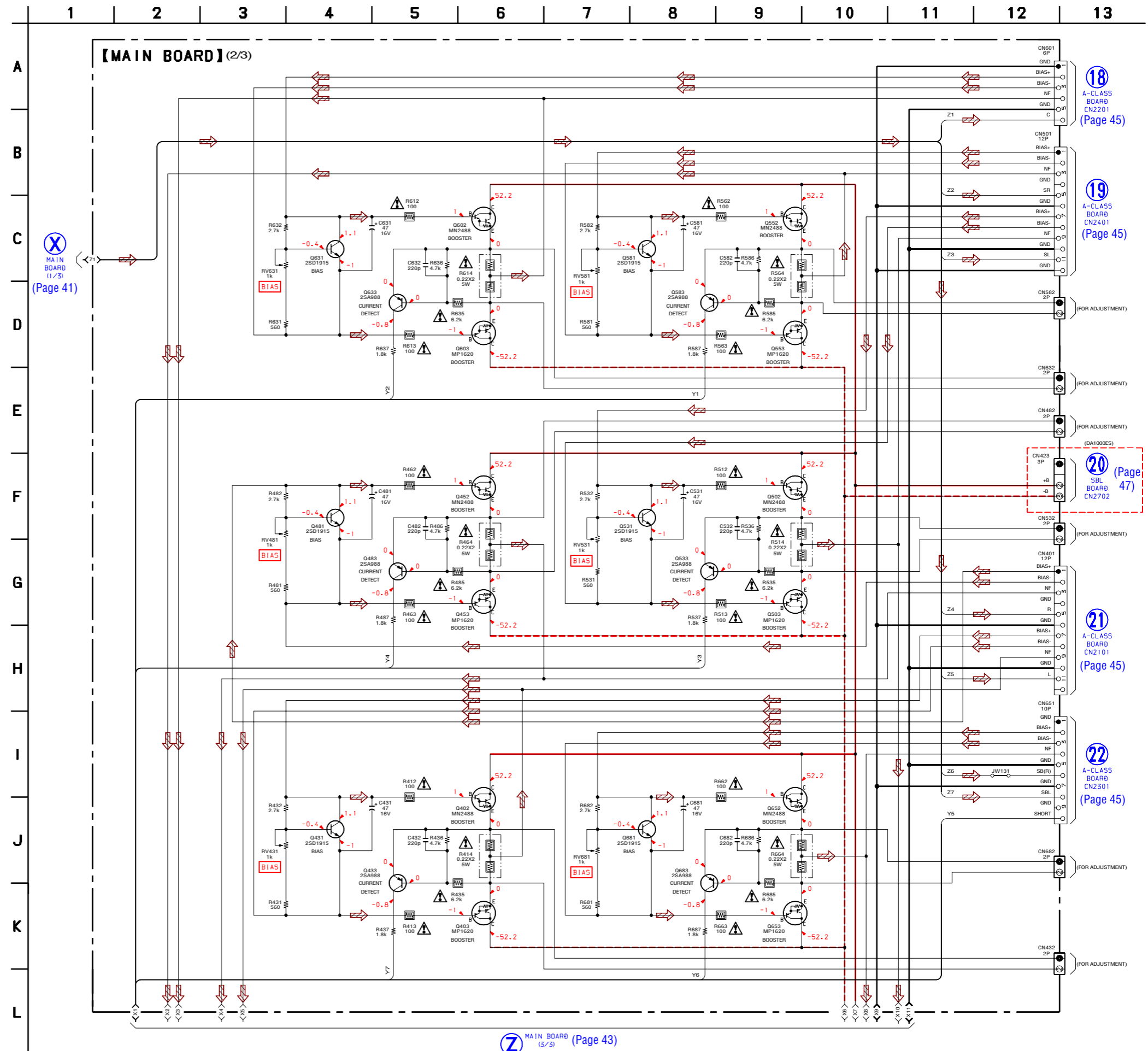

X MAIN BOARD (1/3) (Page 41)

Z MAIN BOARD (3/3) (Page 43)

18 A-CLASS BOARD CN2201 (Page 45)

19 A-CLASS BOARD CN2401 (Page 45)

20 SBL BOARD CN2702 (Page 47)

21 A-CLASS BOARD CN2101 (Page 45)

22 A-CLASS BOARD CN2301 (Page 45)

The components identified by mark Δ or dotted line with mark Δ are critical for safety. Replace only with part number specified.

Les composants identifiés par une marque Δ sont critiques pour la sécurité. Ne les remplacer que par une pièce portant le numéro spécifié.

以阴影和 Δ 标志来识别的零部件在安全方面具有关键性。因此只能以规定号码的零部件来更换。

6-25. SCHEMATIC DIAGRAM – MAIN Board (3/3) –

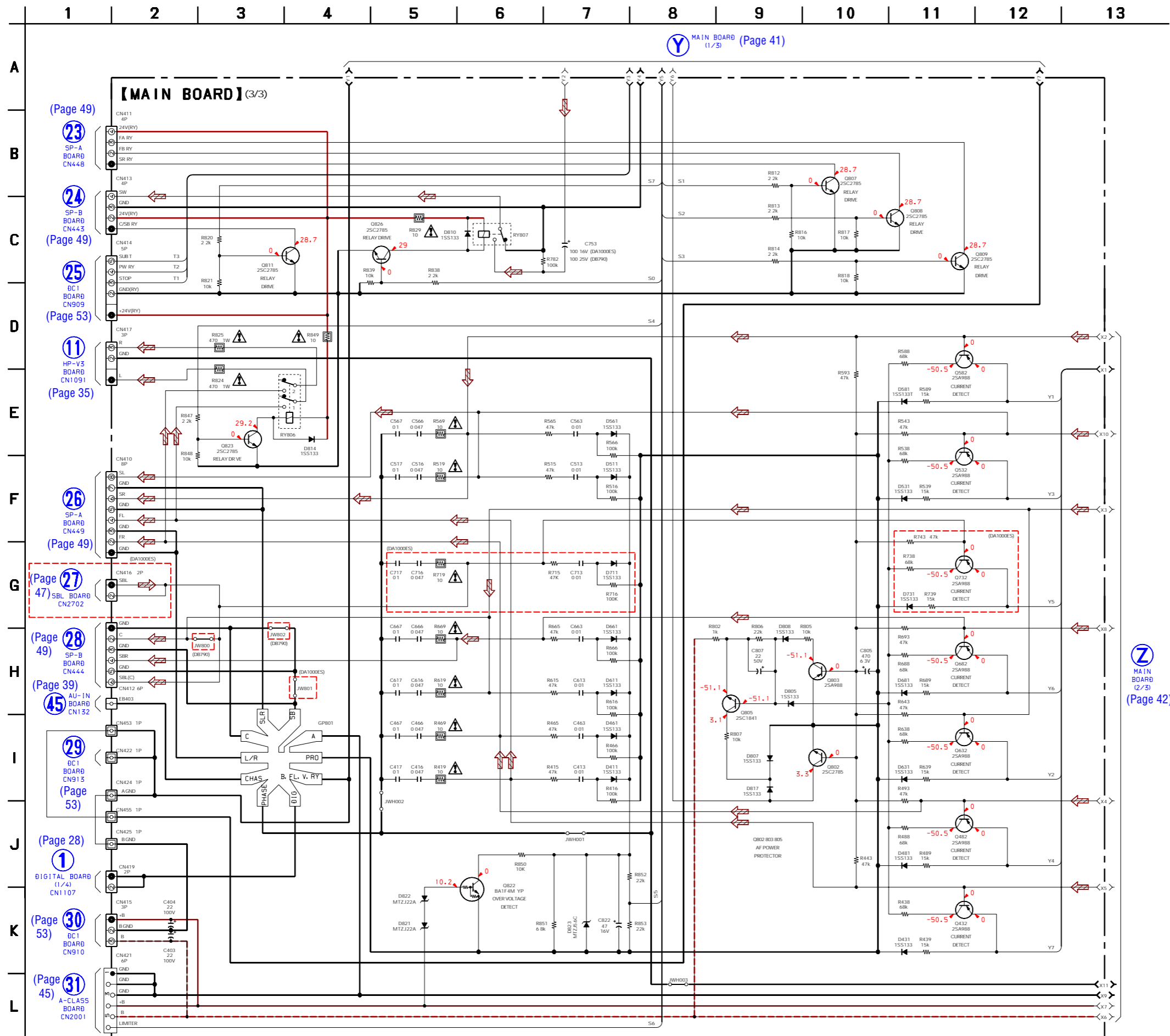

The components identified by mark \triangle or dotted line with mark \triangle are critical for safety. Replace only with part number specified.

Les composants identifiés par une marque \triangle sont critiques pour la sécurité. Ne les remplacer que par une pièce portant le numéro spécifié.

以阴影和 \triangle 标志来识别的零部件在安全方面具有关键性。因此只能以规定号码的零部件来更换。

6-26. PRINTED WIRING BOARD – A-CLASS Board – • See page 25 for Circuit Boards Location.  :Uses unleaded solder.

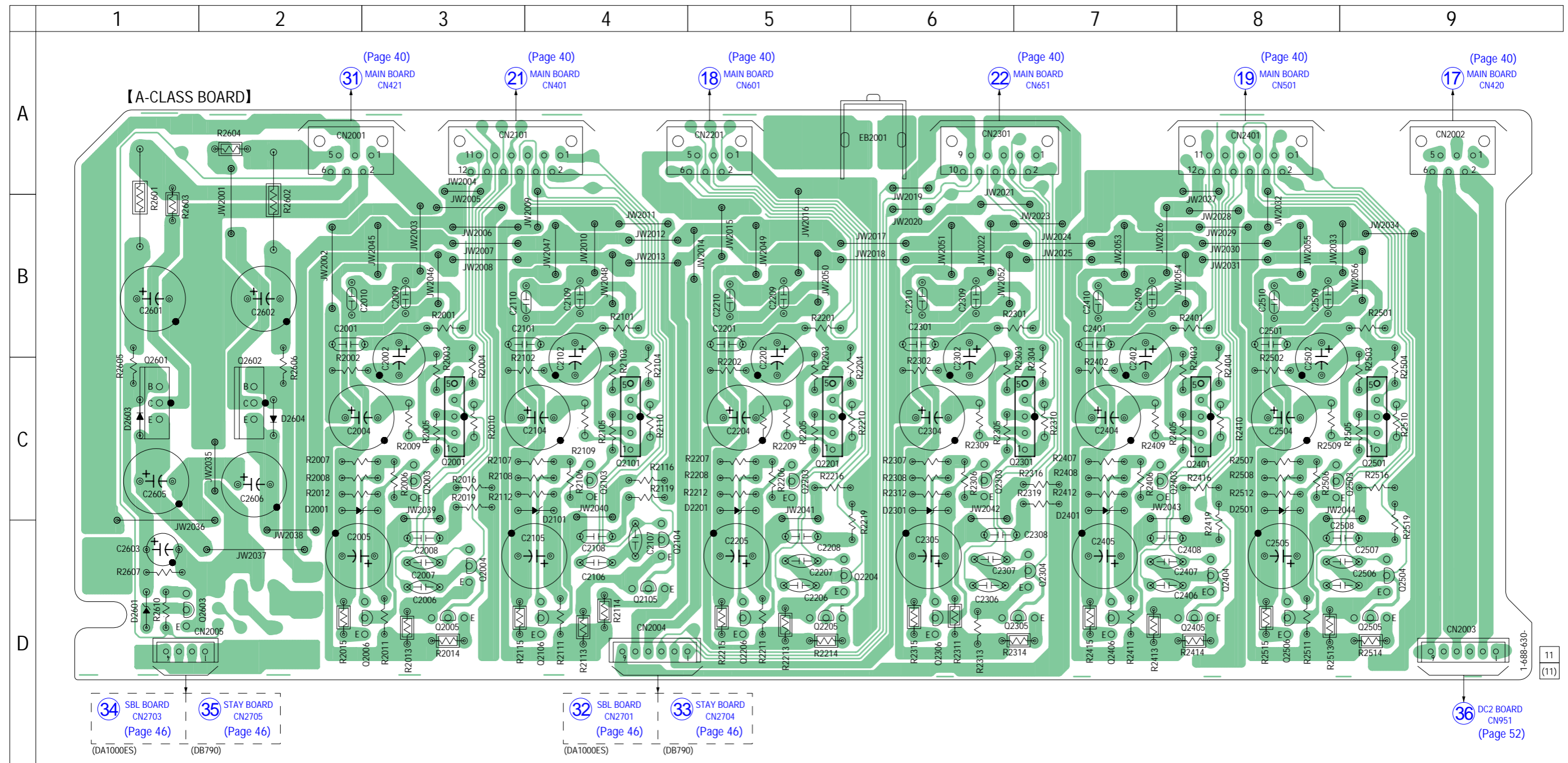

• Semiconductor Location

Ref. No.	Location	Ref. No.	Location	Ref. No.	Location	Ref. No.	Location
D2001	C-2	Q2001	C-3	Q2203	C-5	Q2404	D-8
D2101	C-4	Q2003	C-3	Q2204	D-5	Q2405	D-8
D2201	C-5	Q2004	D-3	Q2205	D-5	Q2406	D-7
D2301	C-6	Q2005	D-3	Q2206	D-5	Q2501	C-9
D2401	C-7	Q2006	D-3	Q2301	C-7	Q2503	C-8
D2501	C-8	Q2101	C-4	Q2303	C-6	Q2504	D-9
D2601	D-1	Q2103	C-4	Q2304	D-7	Q2505	D-9
D2603	C-1	Q2104	D-4	Q2305	D-7	Q2506	D-8
D2604	C-2	Q2105	D-4	Q2306	D-6	Q2601	C-1
		Q2106	D-4	Q2401	C-8	Q2602	C-2
		Q2201	C-5	Q2403	C-7	Q2603	D-1

6-27. SCHEMATIC DIAGRAM – A-CLASS Board –

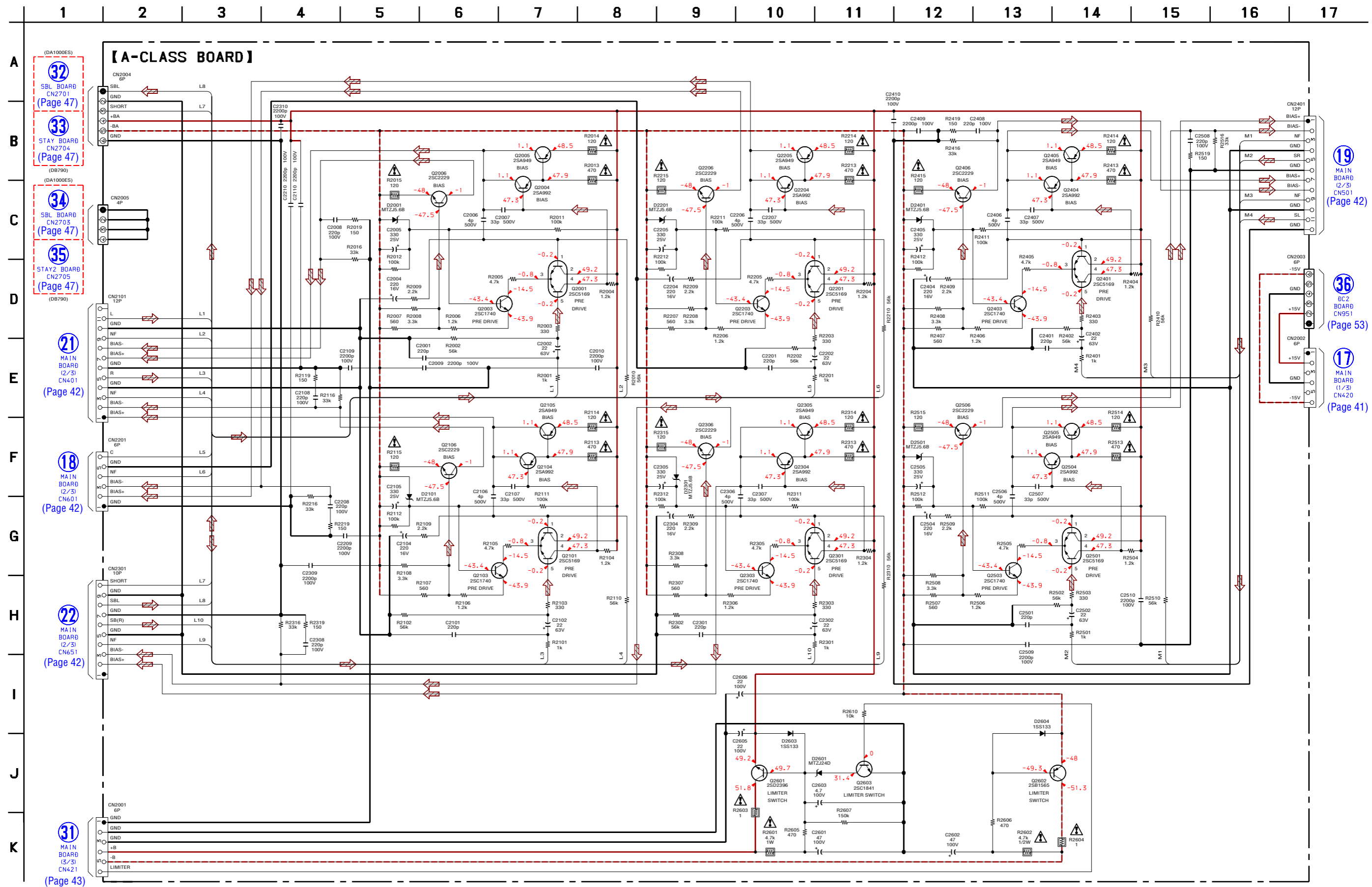

The components identified by mark Δ or dotted line with mark Δ are critical for safety. Replace only with part number specified.

Les composants identifiés par une marque Δ sont critiques pour la sécurité. Ne les remplacer que par une pièce portant le numéro spécifié.

以阴影和△标志来识别的零部件在安全方面具有关键性。因此只能以规定号码的零部件来更换。

6-28. PRINTED WIRING BOARDS – SBL/STAY/STAY2 Boards – • See page 25 for Circuit Boards Location.

 :Uses unleaded solder.

• Semiconductor Location

Ref. No.	Location
D2701	B-3
Q702	D-3
Q703	D-4
Q731	D-3
Q733	B-2
Q2701	B-4
Q2703	B-3
Q2704	B-3
Q2705	B-3
Q2706	B-2

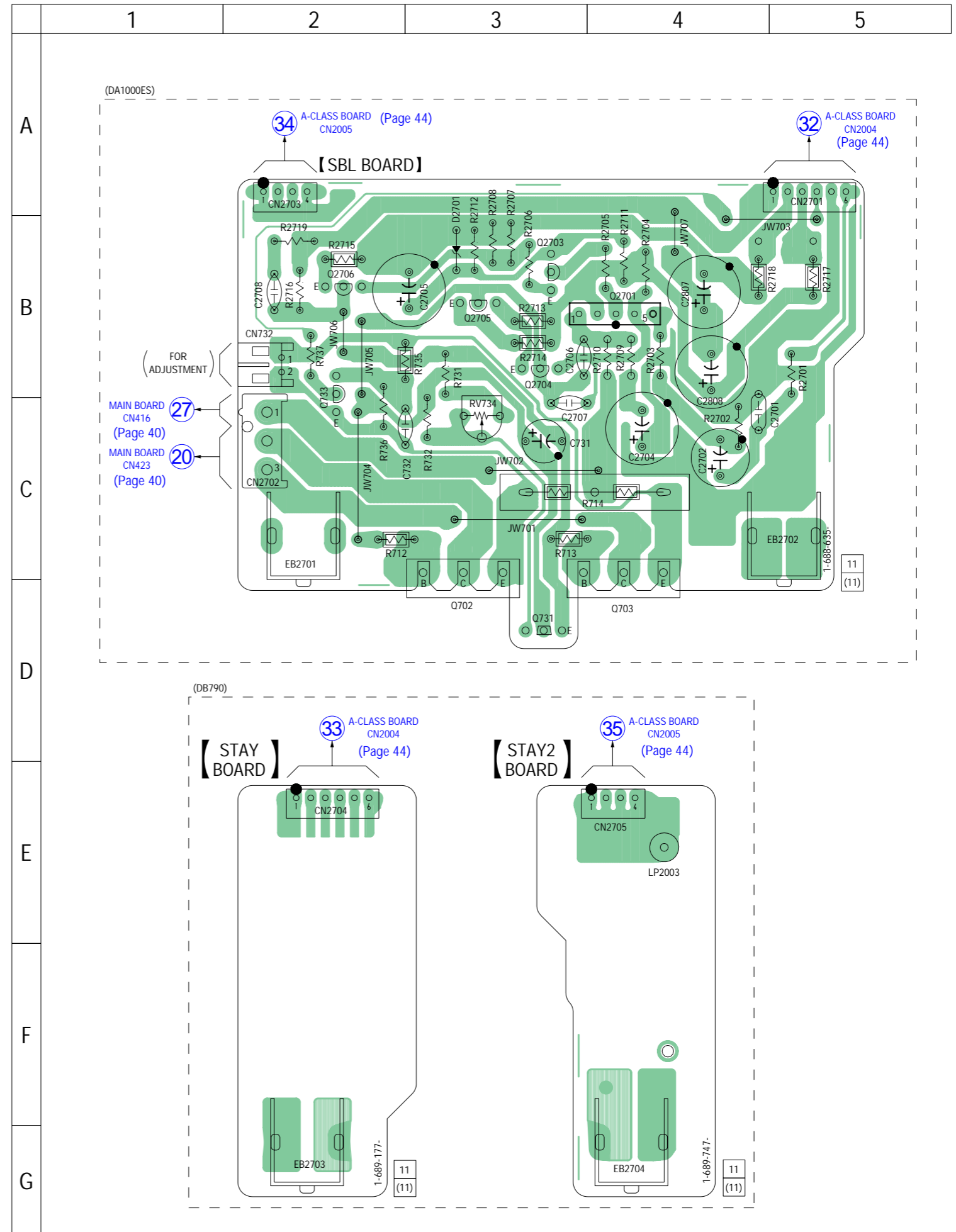

6-29. SCHEMATIC DIAGRAM – SBL/STAY/STAY2 Boards –

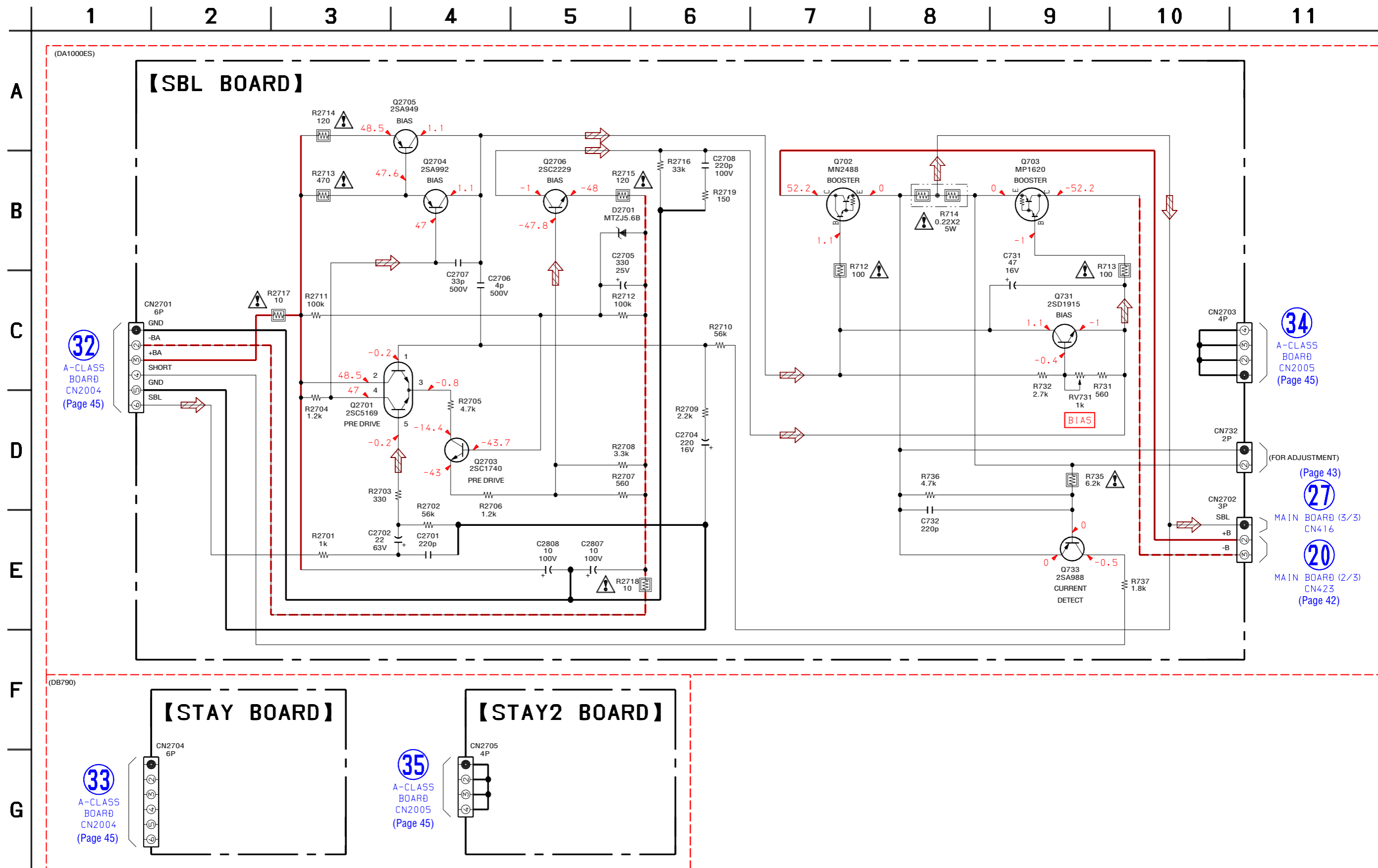

The components identified by mark \triangle or dotted line with mark \triangle are critical for safety. Replace only with part number specified.

Les composants identifiés par une marque \triangle sont critiques pour la sécurité. Ne les remplacer que par une pièce portant le numéro spécifié.

以阴影和 \triangle 标志来识别的零部件在安全方面具有关键性。因此只能以规定号码的零部件来更换。

6-30. PRINTED WIRING BOARDS – SP-A/SP-B/STAY3/STAY4 Boards – • See page 25 for Circuit Boards Location.  :Uses unleaded solder.

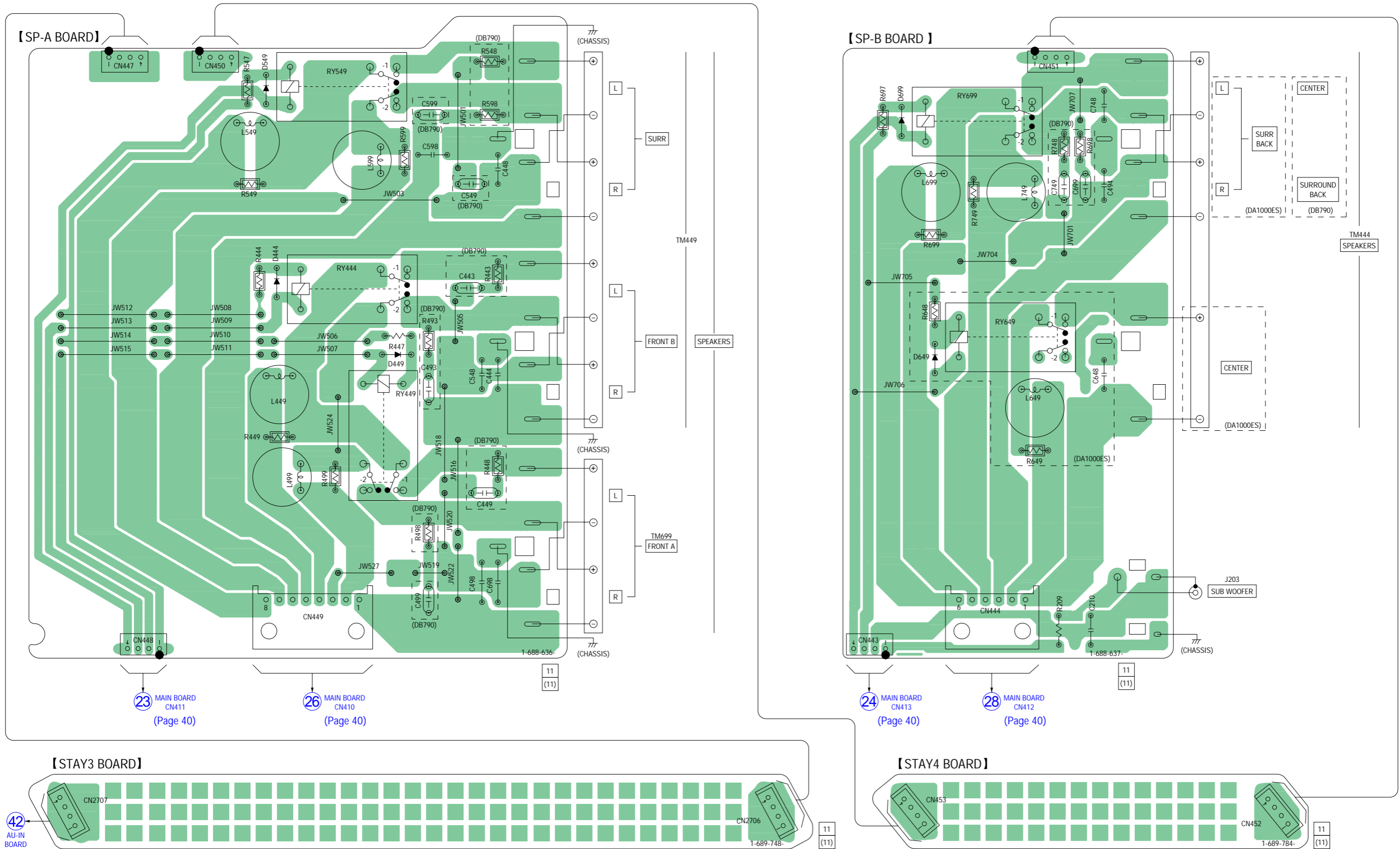

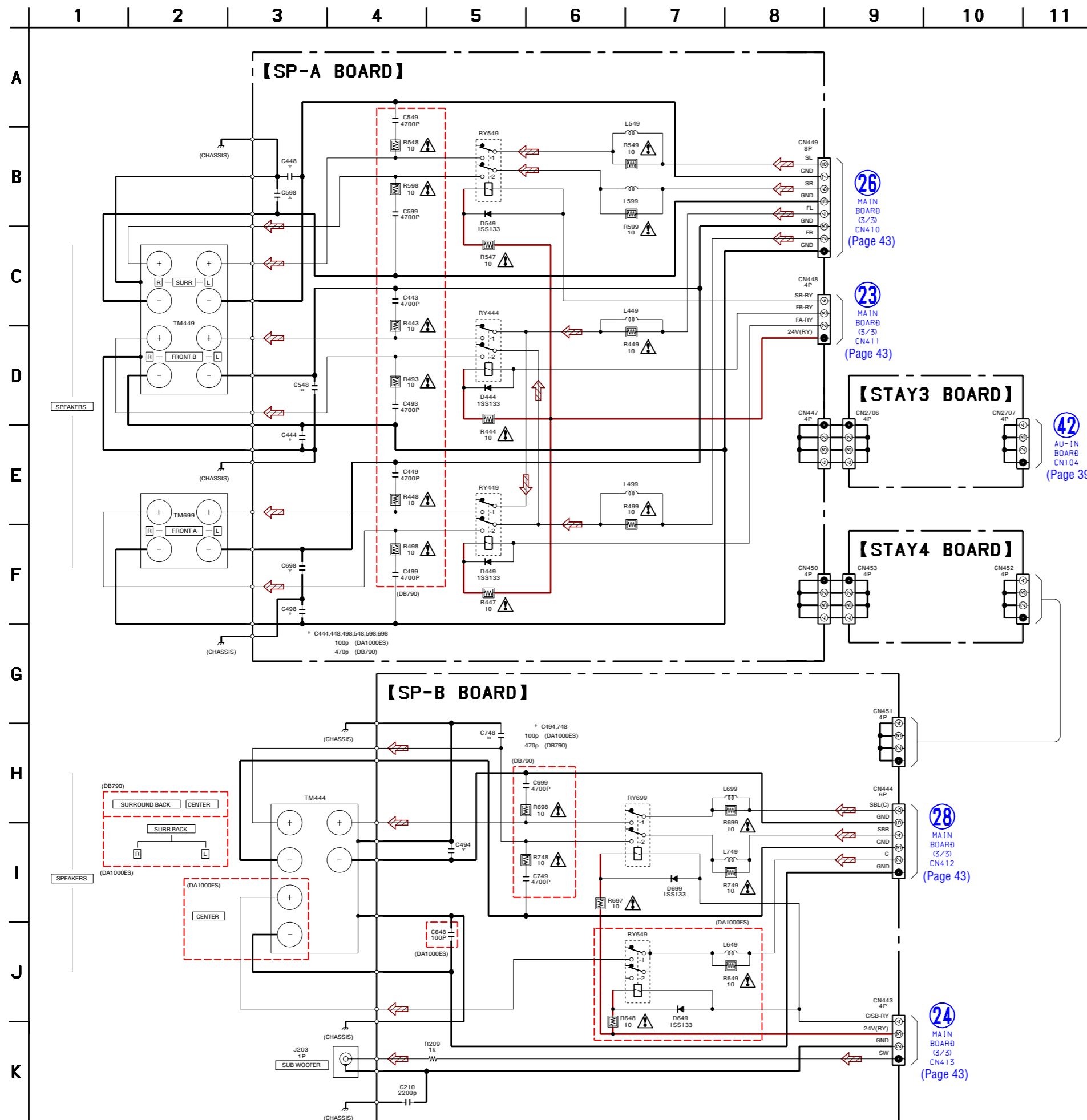

The components identified by mark \triangle or dotted line with mark \triangle are critical for safety. Replace only with part number specified.

Les composants identifiés par une marque \triangle sont critiques pour la sécurité. Ne les remplacer que par une pièce portant le numéro spécifié.

以阴影和 \triangle 标志来识别的零部件在安全方面具有关键性。因此只能以规定号码的零部件来更换。

6-32. PRINTED WIRING BOARDS – DISPLAY/FUN/VOL Boards – • See page 25 for Circuit Boards Location..  :Uses unleaded solder.

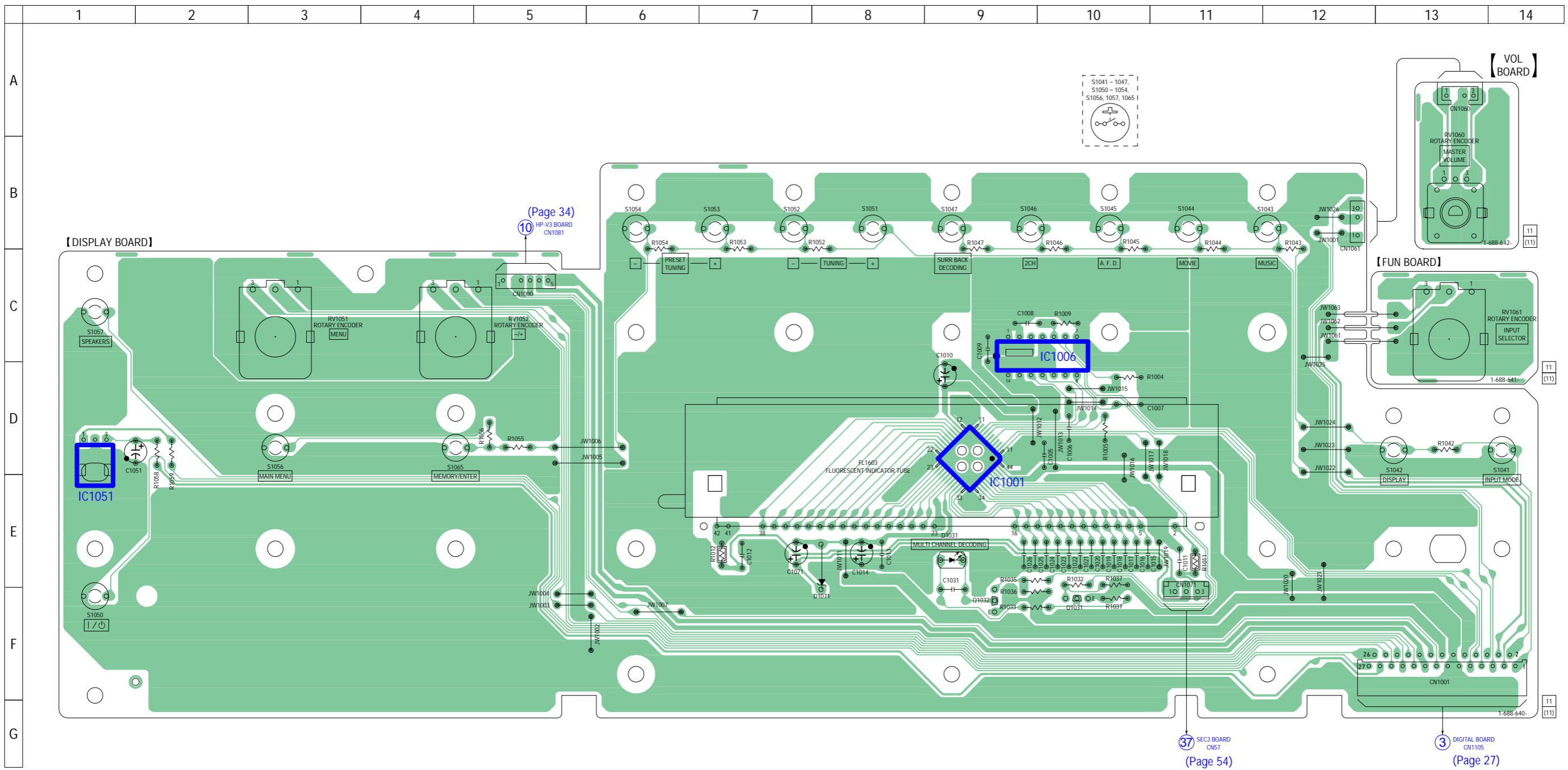

• Semiconductor Location

Ref. No.	Location
D1031	E-9
D1071	E-8
IC1001	D-9
IC1006	C-10
IC1051	D-1
Q1031	F-10
Q1032	F-9

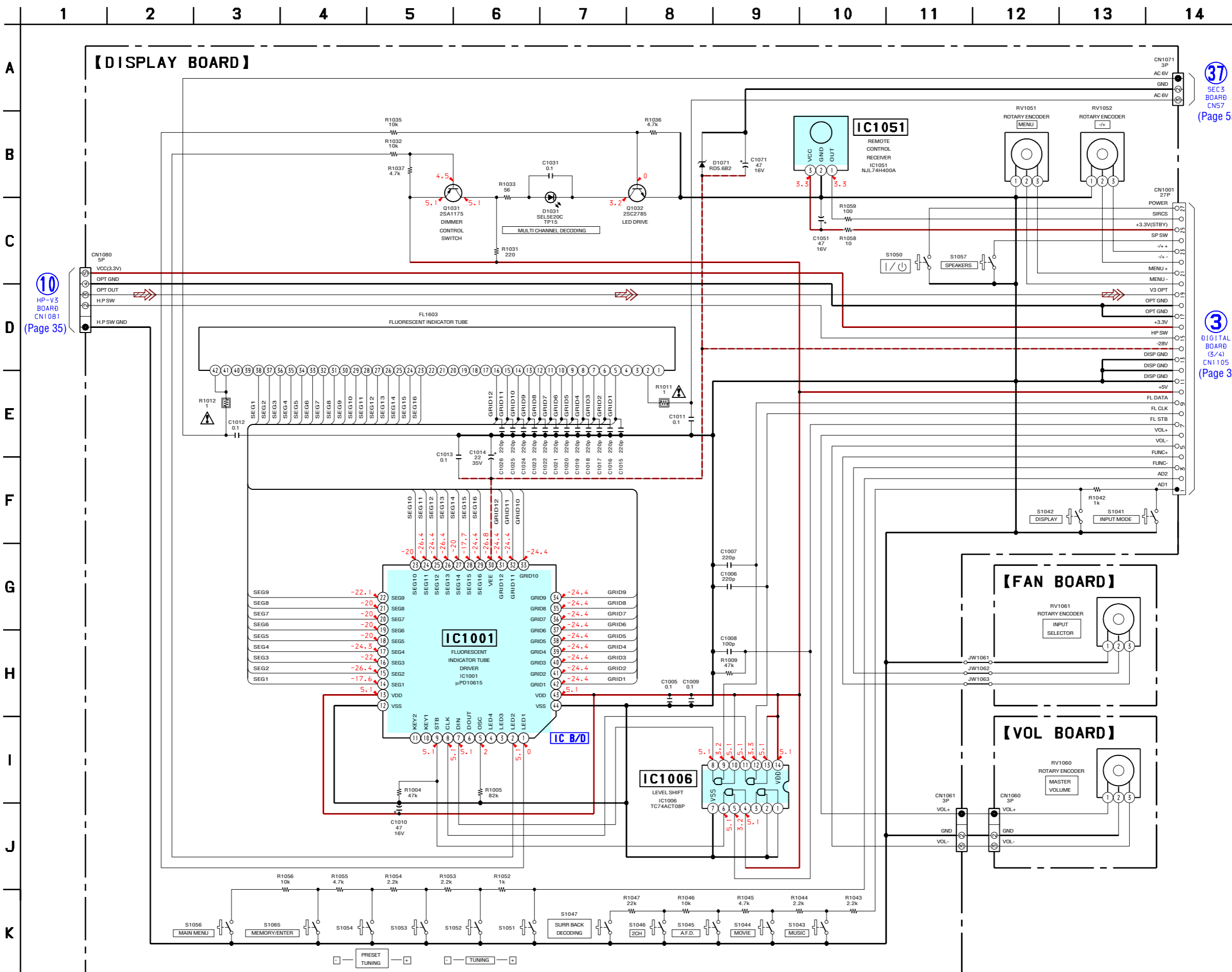

The components identified by mark Δ or dotted line with mark Δ are critical for safety. Replace only with part number specified.

Les composants identifiés par une marque Δ sont critiques pour la sécurité. Ne les remplacer que par une pièce portant le numéro spécifié.

以阴影和 Δ 标志来识别的零部件在安全方面具有关键性。因此只能以规定号码的零部件来更换。

• Semiconductor Location

Ref. No.	Location
D902	G-1
D903	F-4
D904	F-4
D905	E-4
D906	E-4
D908	F-2
D909	H-2
D912	F-2
D913	F-1
D914	G-4
D915	F-1
D916	F-1
IC951	B-2
IC952	C-2
IC953	C-3
IC954	C-4
IC955	C-5
Q903	H-1
Q953	B-3
Q954	B-3
Q955	B-3
Q956	C-2
Q957	C-2
Q958	C-4
Q959	B-4
Q960	B-5
Q961	C-5
Q962	C-5

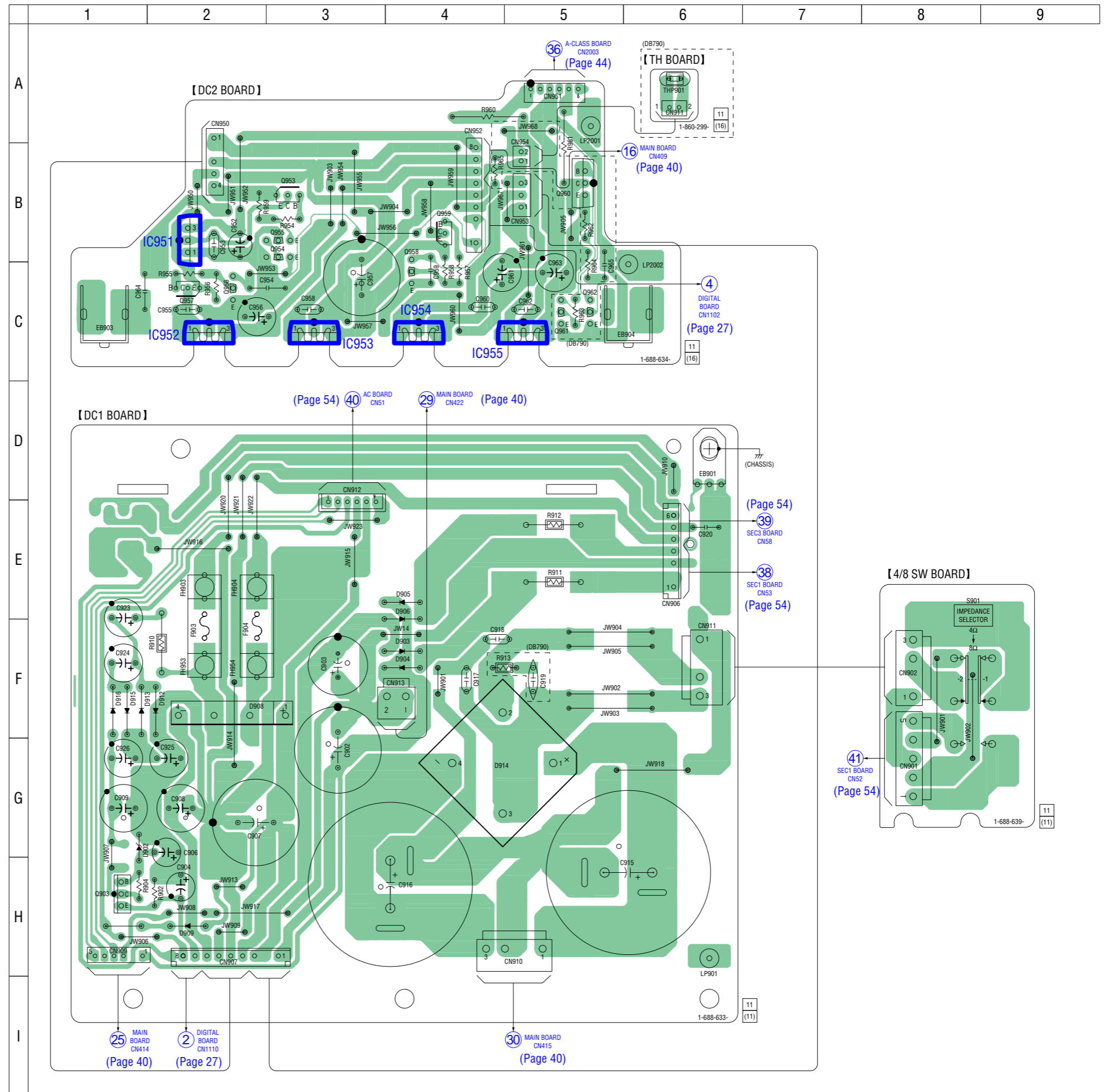

6-35. SCHEMATIC DIAGRAM – DC1/DC2/TH/4/8 SW Boards –

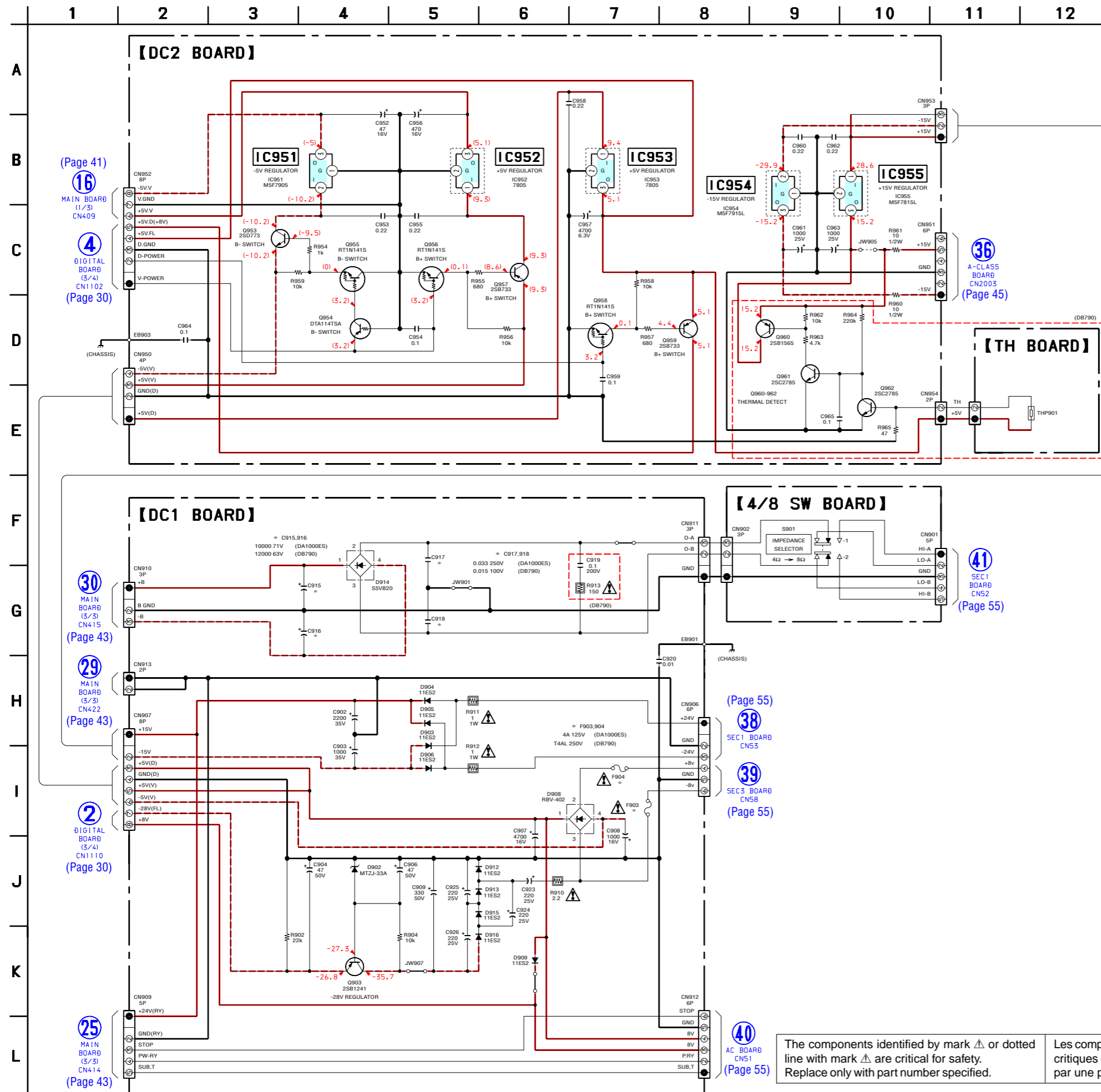

(Page 41)
16 MAIN BOARD (1/3) CN409
(Page 30)
4 DIGITAL BOARD (3/4) CN1102

36 A-CLASS BOARD CN2003 (Page 45)

30 MAIN BOARD (3/3) CN415 (Page 43)
29 MAIN BOARD (3/3) CN422 (Page 43)
2 DIGITAL BOARD (3/4) CN1110 (Page 30)

41 SEC1 BOARD CN52 (Page 55)

(Page 55)
38 SEC1 BOARD CN53
39 SEC3 BOARD CN58 (Page 55)

25 MAIN BOARD (3/3) CN414 (Page 43)

40 AC BOARD CN51 (Page 55)

The components identified by mark \triangle or dotted line with mark \triangle are critical for safety. Replace only with part number specified.

Les composants identifiés par une marque \triangle sont critiques pour la sécurité. Ne les remplacer que par une pièce portant le numéro spécifié.

以阴影和 \triangle 标志来识别的零部件在安全方面具有关键性。因此只能以规定号码的零部件来更换。

6-36. PRINTED WIRING BOARDS – AC/PRI/SEC1/SEC3 Boards – • See page 25 for Circuit Boards Location.  :Uses unleaded solder.

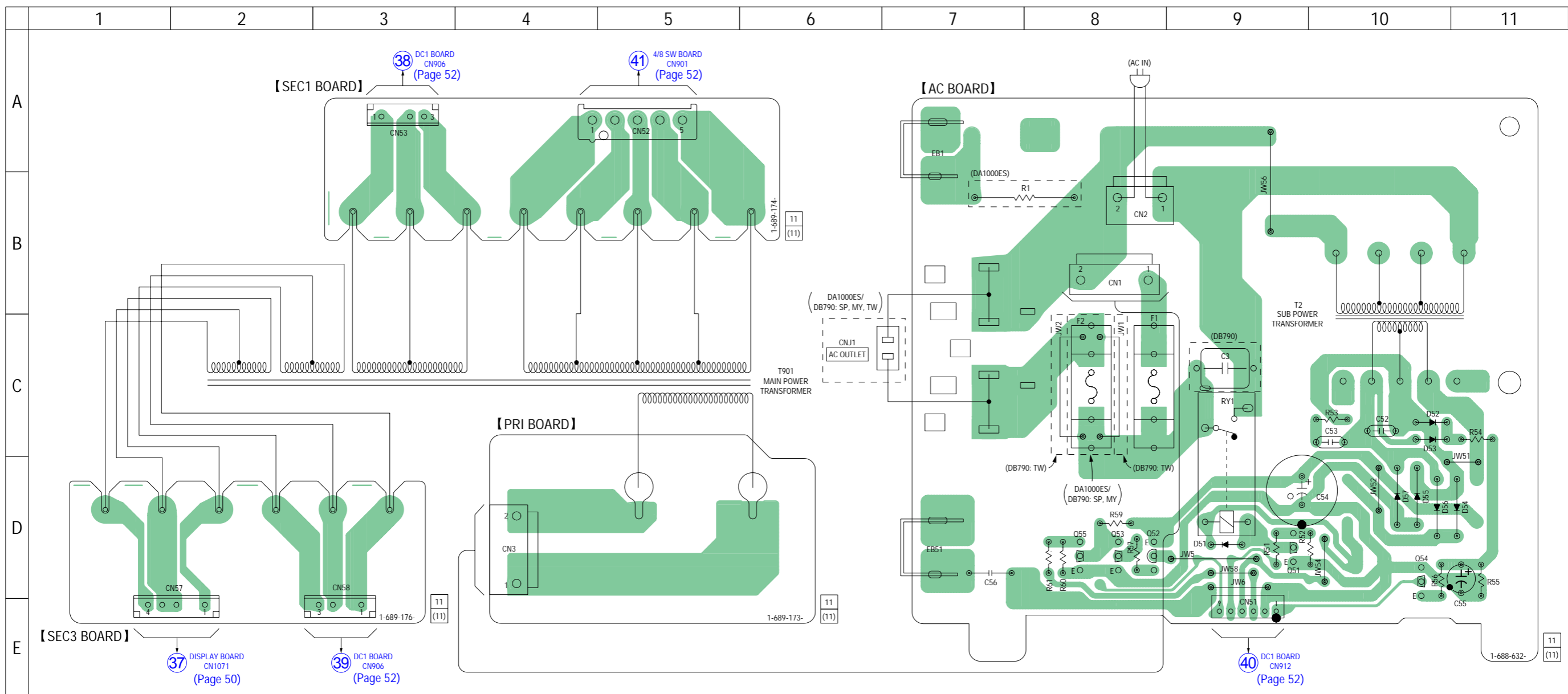

• Semiconductor Location

Ref. No.	Location
D51	D-9
D52	C-10
D53	C-10
D54	D-11
D55	D-10
D56	D-10
D57	D-10
Q51	D-9
Q52	D-8
Q53	D-8
Q54	D-10
Q55	D-8

6-37. SCHEMATIC DIAGRAM – AC/PRI/SEC1/SEC3 Boards –

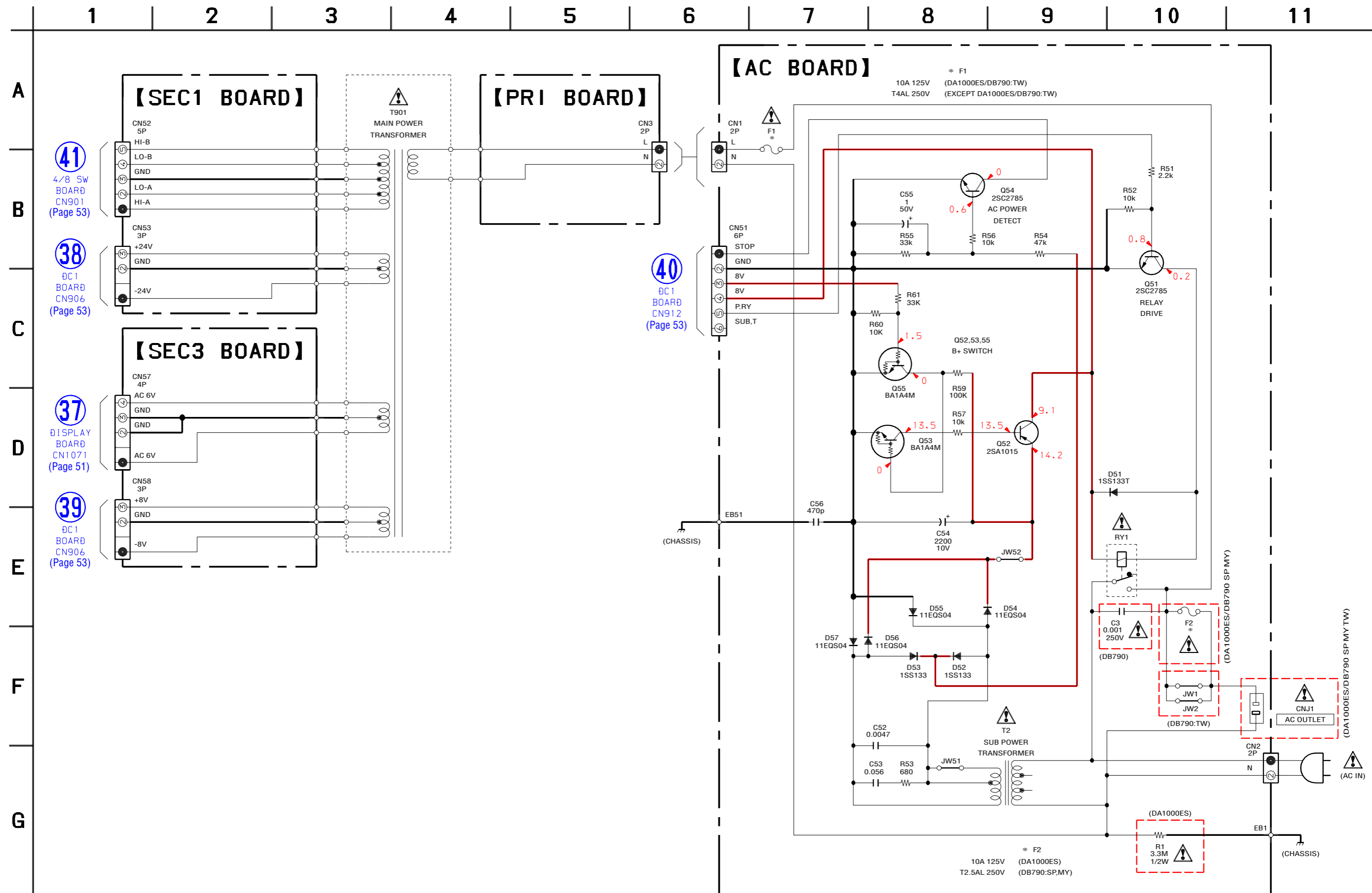

41
4/8 SW BOARD
CN901
(Page 53)

38
DC1 BOARD
CN906
(Page 53)

37
DISPLAY BOARD
CN1071
(Page 51)

39
DC1 BOARD
CN906
(Page 53)

40
DC1 BOARD
CN912
(Page 53)

The components identified by mark \triangle or dotted line with mark \triangle are critical for safety. Replace only with part number specified.

Les composants identifiés par une marque \triangle sont critiques pour la sécurité. Ne les remplacer que par une pièce portant le numéro spécifié.

以阴影和 \triangle 标志来识别的零部件在安全方面具有关键性。因此只能以规定号码的零部件来更换。

• Waveforms
– DIGITAL Board –

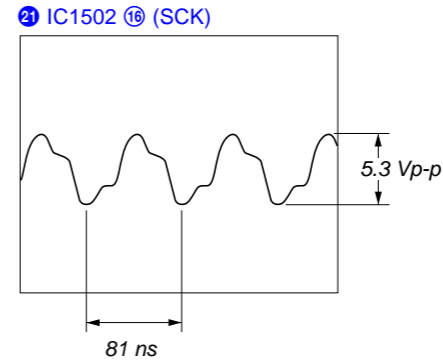
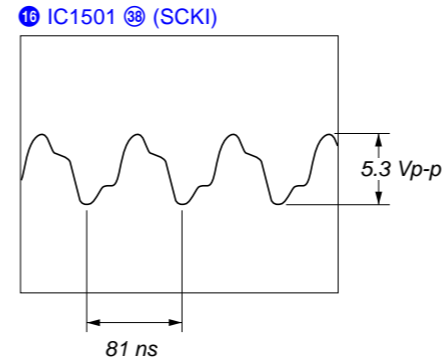
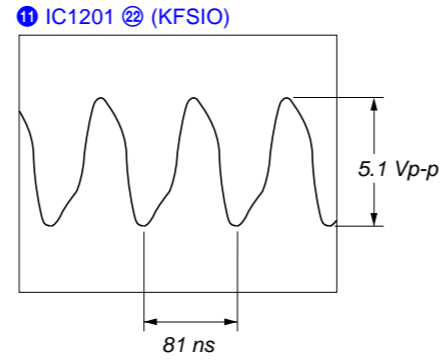
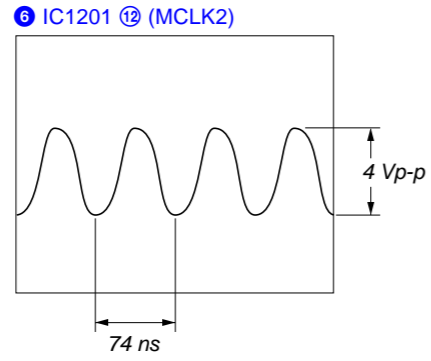
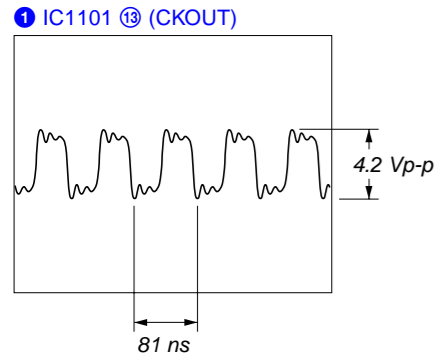

– COMP-V Board –

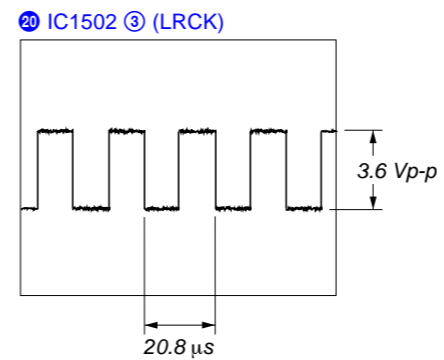
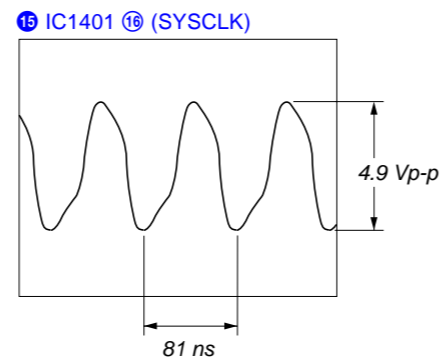
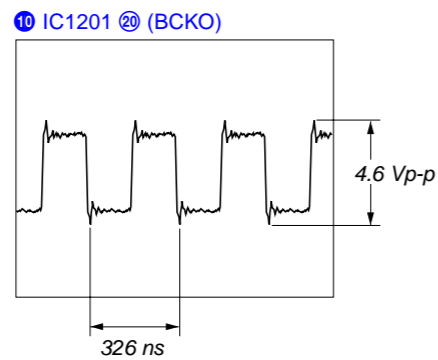
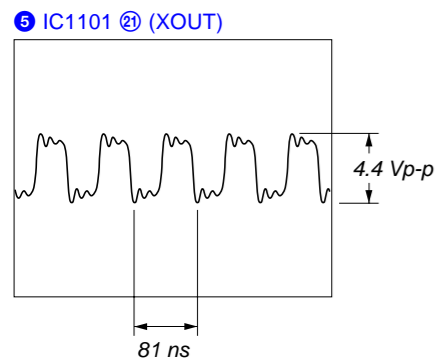
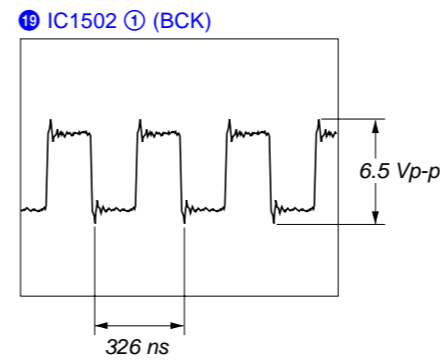
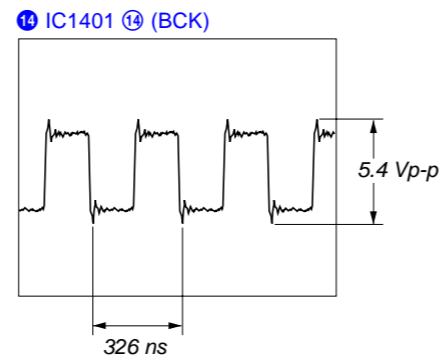
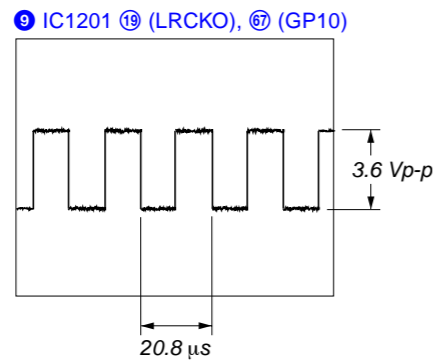
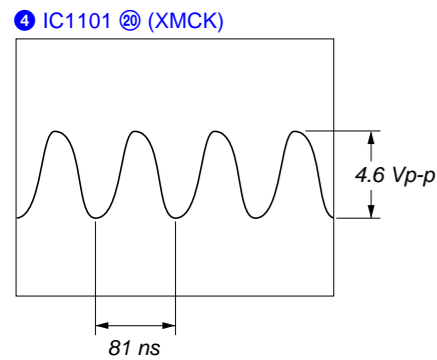
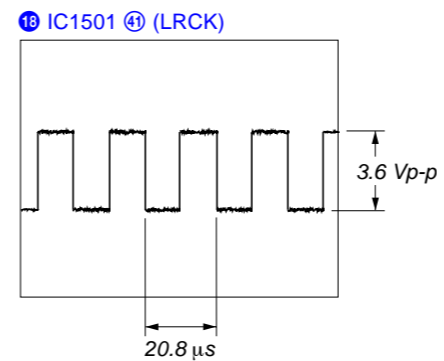
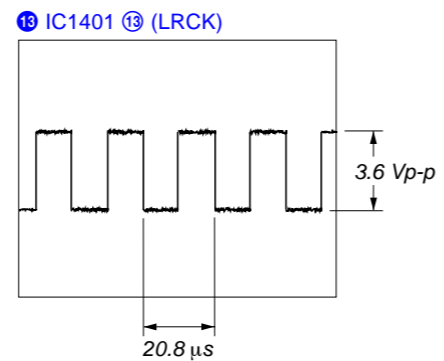
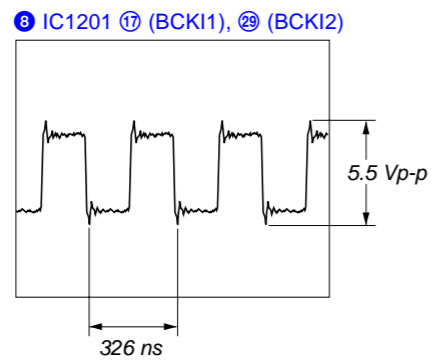
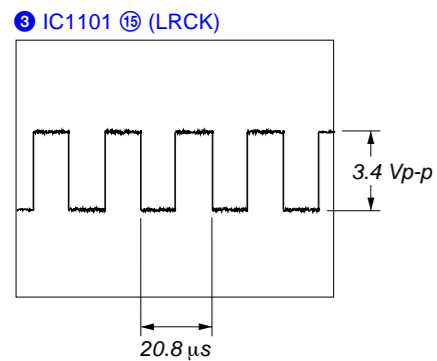
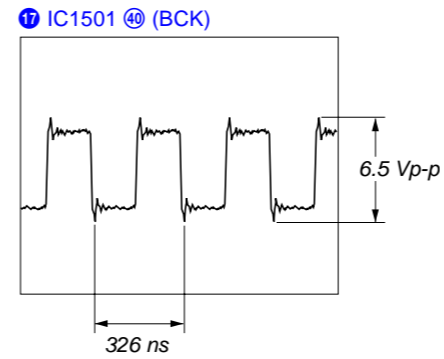
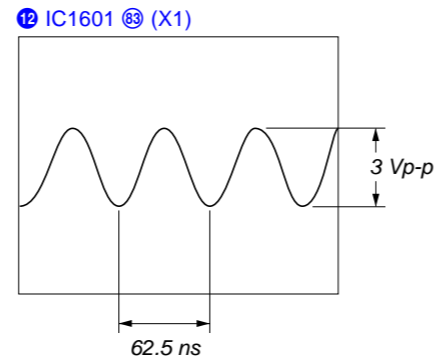
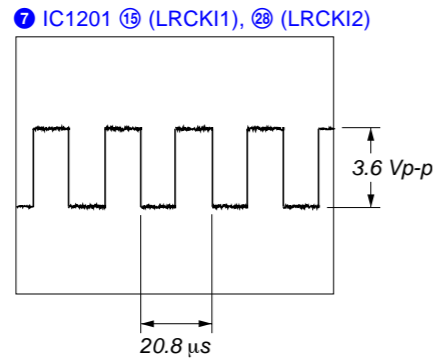
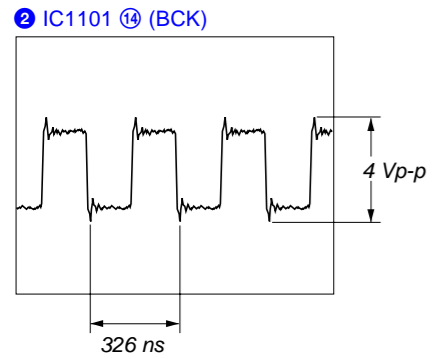
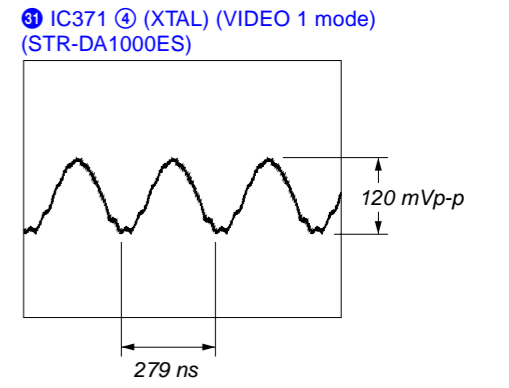

• IC Block Diagrams

IC101 TC9274N-017 (AU-IN board)

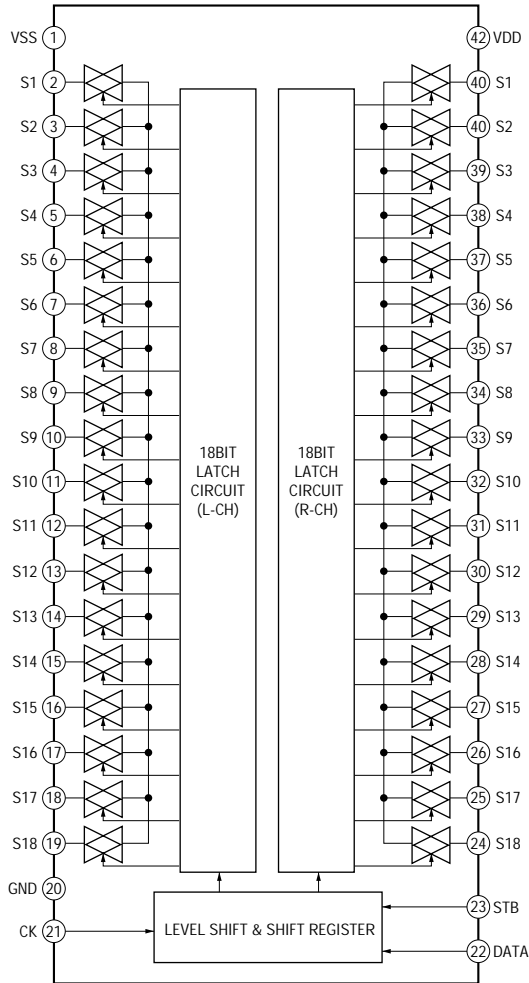

IC173 TC9273F-012 (EL) (AU-IN Board)
IC201 TC9273N-014 (VIDEO-AU Board)

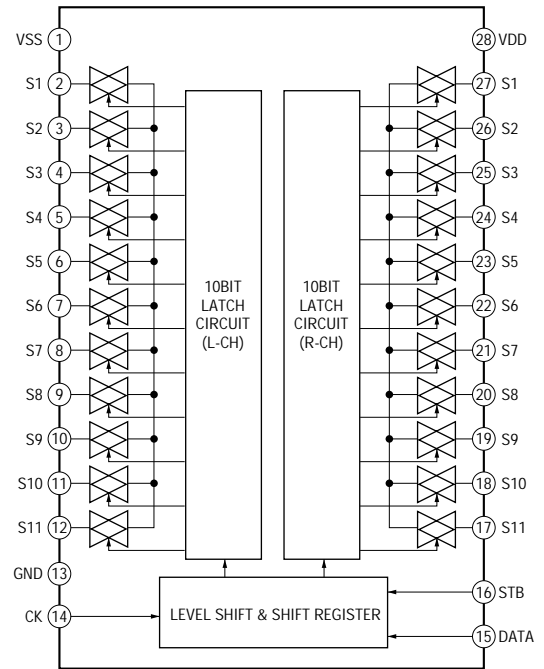

IC301 NJM2595D (VIDEO Board)
IC850, 851 NJM2595D (S-VIDEO Board)

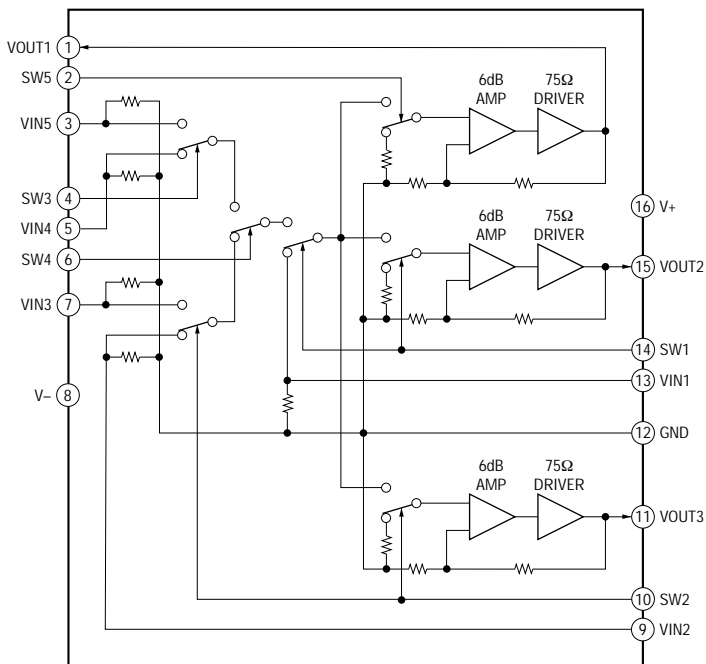

IC370 TC90A45F (COMP-V Board (STR-DA1000ES))

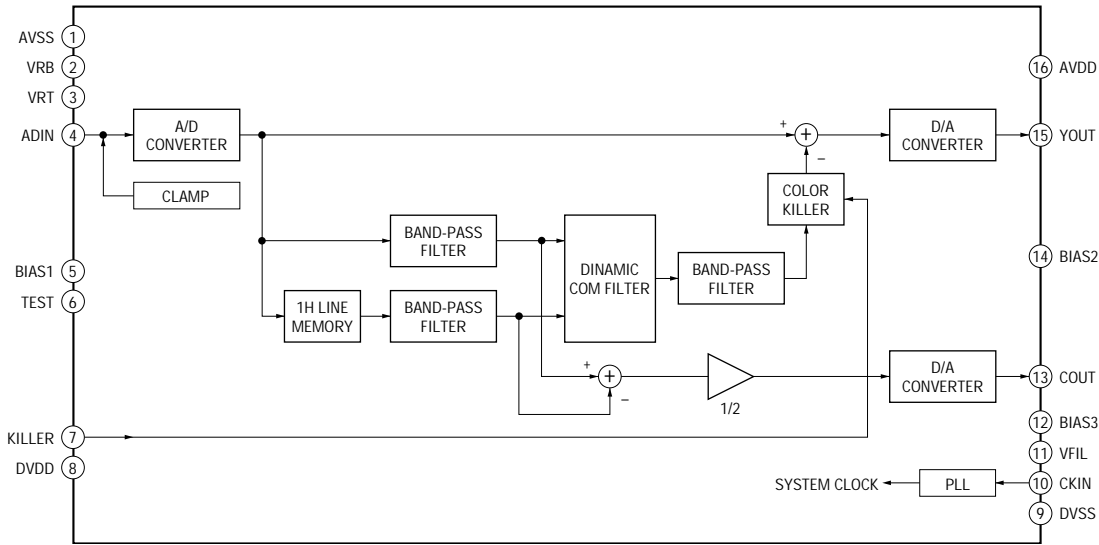

IC371 MM1093NF (COMP-V Board (STR-DA1000ES))

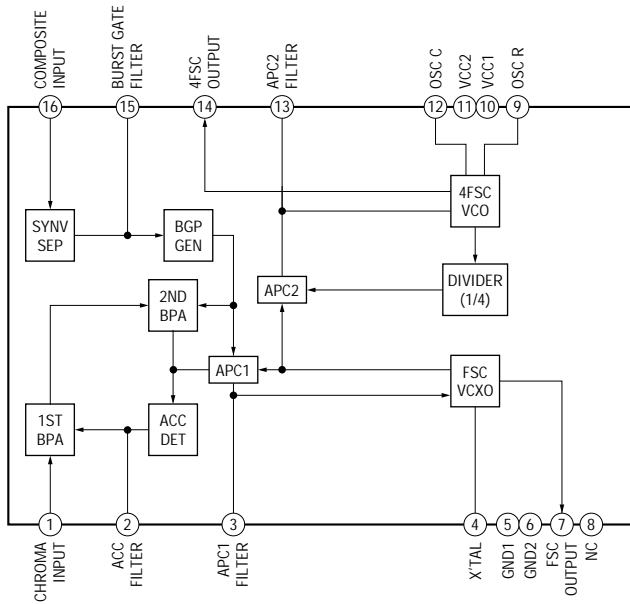

IC372 NJM2268D (COMP-V Board (STR-DA1000ES))

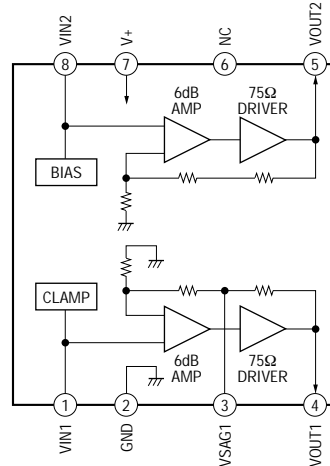

IC401, 501, 601, 651 CXD9275M (MAIN Board)

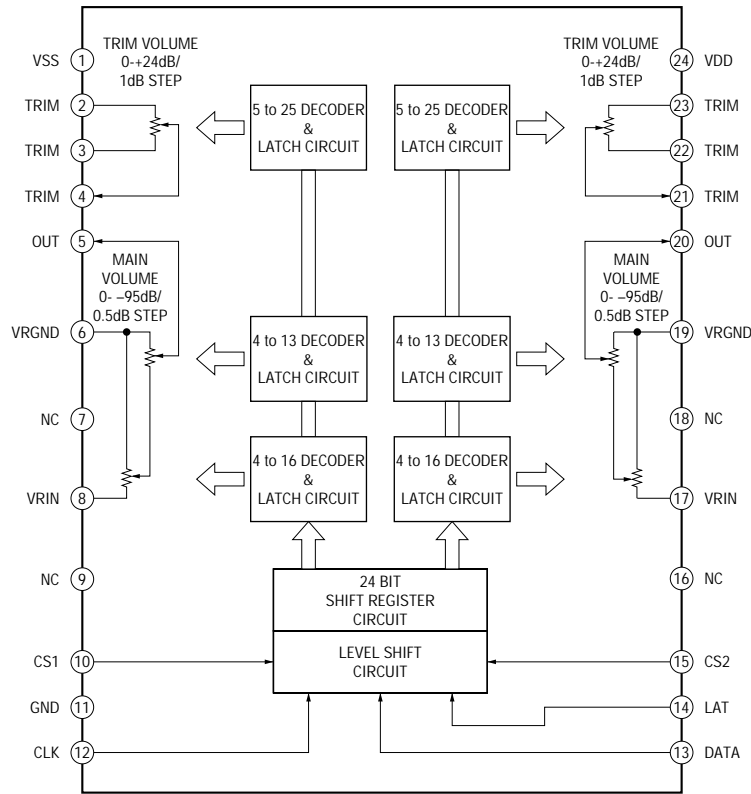

IC852 LA7213 (S-VIDEO Board (STR-DA1000ES))

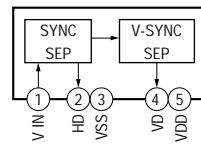

IC1001 μ PD16315GB-3BS (DISPLAY Board)

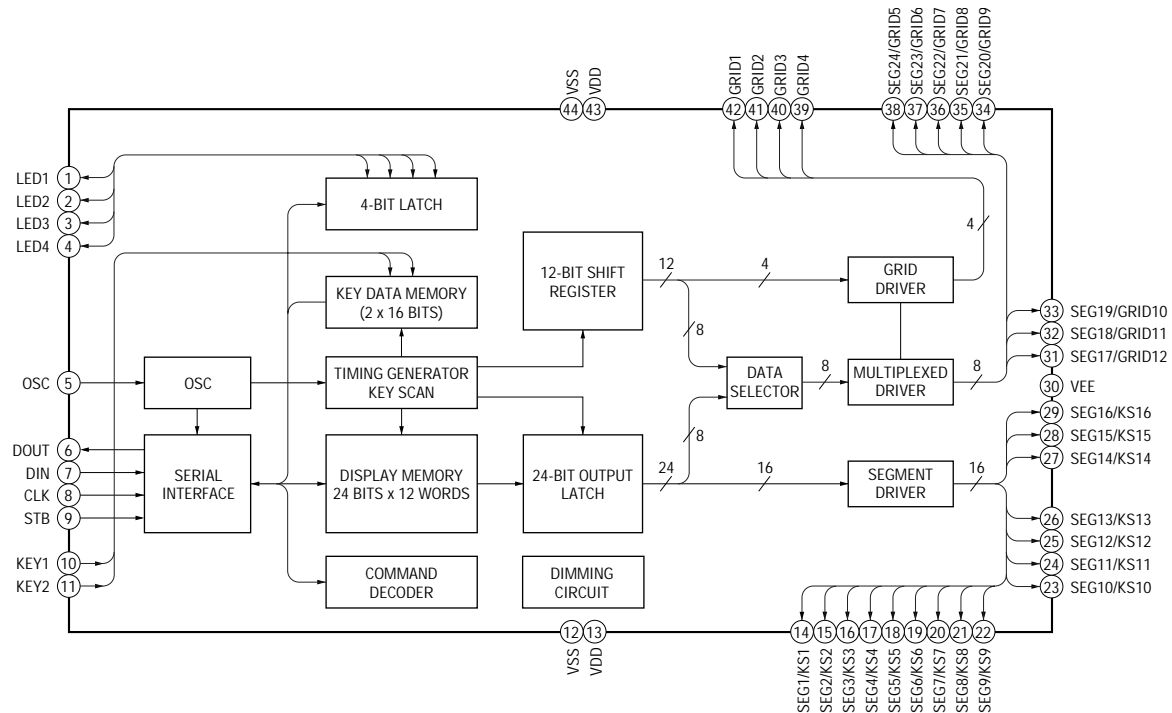

IC1101 LC89056W-E (DIGITAL Board)

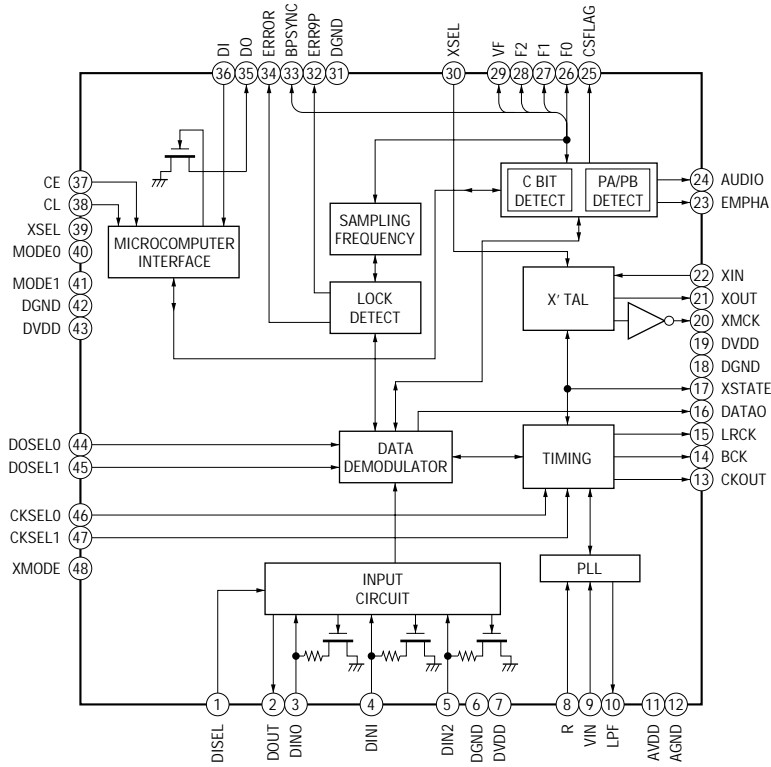

IC1103 SN74HC153ANS (DIGITAL Board)

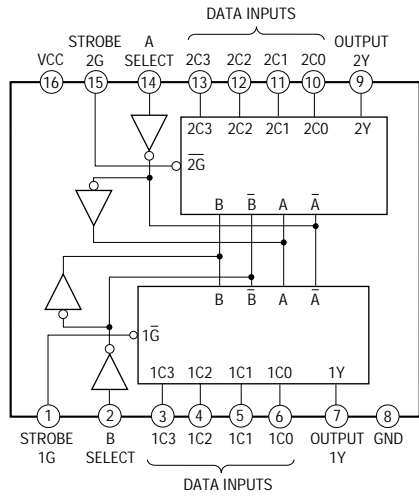

IC1204 TC7WH157FU (TE12R) (DIGITAL Board)

IC1504 TC7WH157FU (TE12R) (DIGITAL Board (STR-DA1000ES))

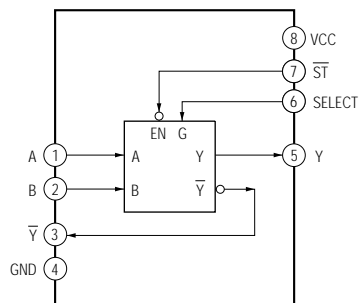

IC1401 PCM1800E/2K (DIGITAL Board)

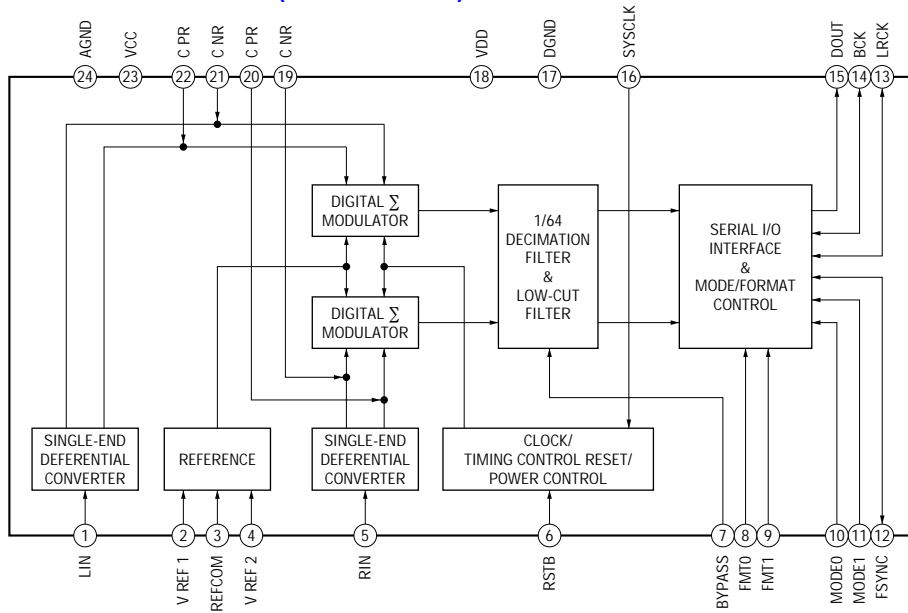

IC1501 PCM1604Y/2K (DIGITAL Board)

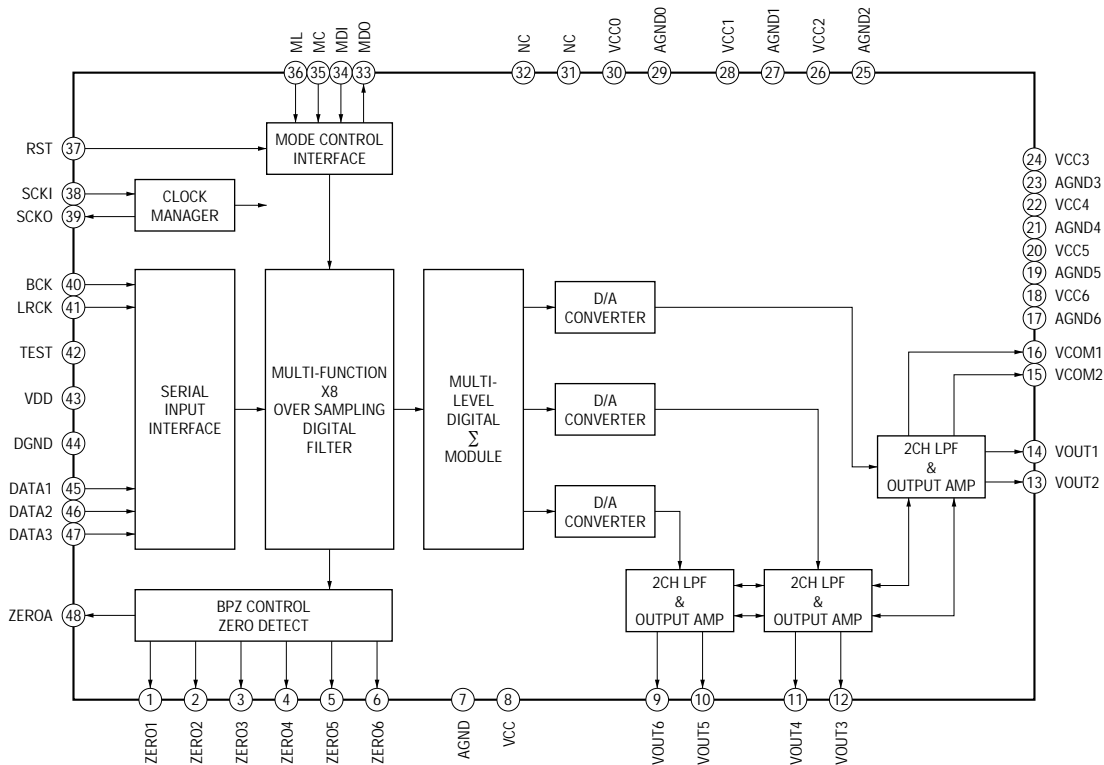

IC1502 PCM1748E/2K (DIGITAL Board)

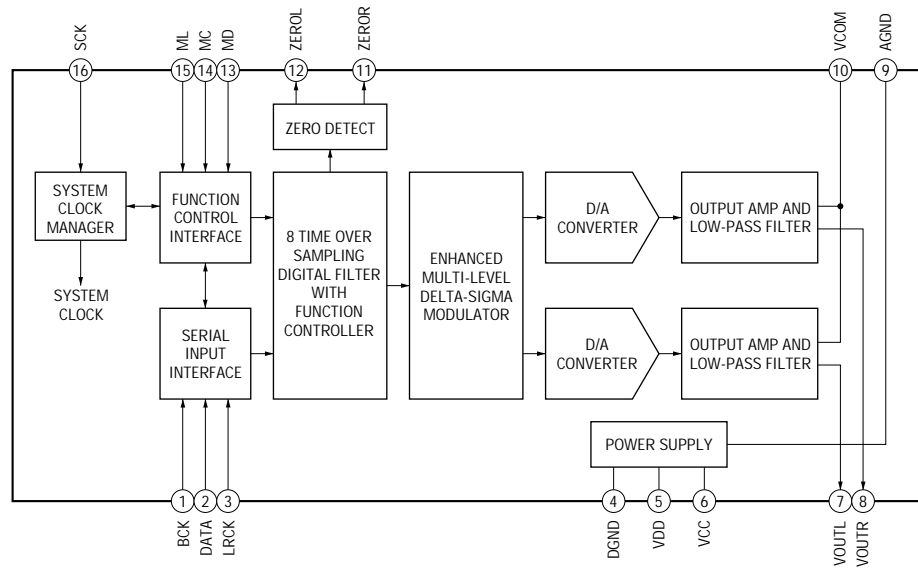

6-38. IC PIN FUNCTION DESCRIPTION

• DIGITAL BOARD IC1101 LC89056W-E (DIGITAL AUDIO INTERFACE RECEIVER)

Pin No.	Pin Name	I/O	Description
1	DISEL	I	Selection signal input terminal of data input terminal Fixed at "L" in this set
2	DOUT	O	Digital data output to the external output terminal
3 to 5	DIN0 to DIN2	I	Digital data input from the external input terminal
6	DGND	—	Ground terminal (for digital)
7	DVDD	—	Power supply terminal (+3.3V) (for digital)
8	R	I	Input terminal for VCO gain control
9	VIN	I	Input terminal for VCO free-run frequency setting
10	LPF	O	PLL loop filter setting terminal
11	AVDD	—	Power supply terminal (+3.3V) (for analog)
12	AGND	—	Ground terminal (for analog)
13	CKOUT	O	Audio clock signal output to the audio digital signal processor and D/A converter
14	BCK	O	Bit clock signal (2.8224 MHz) output to the audio digital signal processor and A/D converter
15	LRCK	O	L/R sampling clock signal (44.1 kHz) output to the audio digital signal processor and A/D converter
16	DATAO	O	Audio serial data output to the audio digital signal processor and system controller
17	XSTATE	O	Source clock selection monitor output to the system controller
18	DGND	—	Ground terminal (for digital)
19	DVDD	—	Power supply terminal (+3.3V) (for digital)
20	XMCK	O	System clock signal (12.288 MHz) output to the A/D converter
21	XOUT	O	System clock output terminal (12.288 MHz)
22	XIN	I	System clock input terminal (12.288 MHz)
23	EMPHA	O	Channel status emphasis information output terminal Not used
24	AUDIO	O	Channel status bit 1 output to the audio digital signal processor
25	CSFLAG	O	Channel status head 40 bit renewal flag output terminal Not used
26 to 29	F0/P0/C0 to F3/P3/C3	O	Output terminal of input frequency calculation result Not used
30	DVDD	—	Power supply terminal (+3.3V) (for digital)
31	DGND	—	Ground terminal (for digital)
32	AUTO	O	Not used
33	BPSYNC	O	Non-PCM burst preamble sync signal output terminal Not used
34	ERROR	O	PLL lock error signal and data error flag output to the audio digital signal processor and system controller
35	DO	O	Read data output to the system controller
36	DI	I	Write data input from the system controller
37	CE	I	Chip enable signal input from the system controller
38	CLK	I	Clock signal input from the system controller
39	XSEL	I	Selection signal input terminal of crystal oscillator frequency Fixed at "H" in this set
40, 41	MODE0, MODE1	I	Mode setting terminal Fixed at "L" in this set
42	DGND	—	Ground terminal (for digital)
43	DVDD	—	Power supply terminal (+3.3V) (for digital)
44, 45	DOSEL0, DOSEL1	I	Output data format selection signal input terminal Fixed at "L" in this set
46	CKSEL0	I	Output clock selection signal input terminal Fixed at "L" in this set
47	CKSEL1	I	Output clock selection signal input from the system controller
48	XMODE	I	System reset signal input from the system controller "L": reset

• DIGITAL BOARD IC1201 CXD9718Q (AUDIO DIGITAL SIGNAL PROCESSOR)

Pin No.	Pin Name	I/O	Description
1	VSS	—	Ground terminal
2	XRST	I	System reset signal input from the system controller “L”: reset
3	EXTIN	I	Master clock signal input terminal Not used
4	FS2	I	Sampling frequency selection signal input terminal Not used
5	VDDI	—	Power supply terminal (+2.5V)
6	FS1	I	Sampling frequency selection signal input terminal Not used
7	PLOCK	O	Internal PLL lock signal output terminal Not used
8	VSS	—	Ground terminal
9	MCLK1	I	System clock input terminal (13.5 MHz)
10	VDDI	—	Power supply terminal (+2.5V)
11	VSS	—	Ground terminal
12	MCLK2	O	System clock output terminal (13.5 MHz)
13	MS	I	Master/slave setting terminal “L”: internal clock, “H”: external clock Fixed at “L” in this set
14	SCKOUT	O	Internal system clock output terminal Not used
15	LRCKI1	I	L/R sampling clock signal (44.1 kHz) input from the A/D converter and digital audio interface receiver
16	VDDE	—	Power supply terminal (+3.3V)
17	BCKI1	I	Bit clock signal (2.8224 MHz) input from the A/D converter and digital audio interface receiver
18	SDI1	I	Audio serial data input from the A/D converter
19	LRCKO	O	L/R sampling clock signal (44.1 kHz) output to the D/A converter
20	BCKO	O	Bit clock signal (2.8224 MHz) output to the D/A converter
21	VSS	—	Ground terminal
22	KFSIO	I	Audio clock signal input from the digital audio interface receiver
23 to 26	SDO1 to SDO4	O	Audio serial data output to the D/A converter
27	SPDIF	O	SPDIF signal output terminal Not used
28	LRCKI2	I	L/R sampling clock signal (44.1 kHz) input from the A/D converter and digital audio interface receiver
29	BCKI2	I	Bit clock signal (2.8224 MHz) input from the A/D converter and digital audio interface receiver
30	SDI2	I	Audio serial data input from the digital audio interface receiver
31	VSS	—	Ground terminal
32	HACN	O	Acknowledge signal output to the system controller
33	HDIN	I	Serial data input from the system controller
34	HCLK	I	Serial data transfer clock signal input from the system controller
35	HDOOUT	O	Serial data output to the system controller
36	HCS	I	Chip select input from the system controller
37	SDCLK	I	Write signal input from the system controller
38	CLKEN	O	SD-RAM chip enable output terminal Not used
39	RAS	O	Row address strobe signal output terminal Not used
40	VDDI	—	Power supply terminal (+2.5V)
41	VSS	—	Ground terminal
42	CAS	O	Column address strobe signal output terminal Not used
43	DQM/OE0	O	Output terminal of data input/output mask Not used
44	CS0	O	Chip select signal output to the S-RAM
45	WE0	O	Write enable signal output to the S-RAM

Pin No.	Pin Name	I/O	Description
46	VDDE	—	Power supply terminal (+3.3V)
47	WMD1	I	External memory wait mode setting terminal Fixed at “H” in this set
48	VSS	—	Ground terminal
49	WMD0	I	External memory wait mode setting terminal Fixed at “H” in this set
50	PAGE2	O	External memory page selection signal output terminal Not used
51	VSS	—	Ground terminal
52, 53	PAGE1, PAGE0	O	External memory page selection signal output terminal Not used
54	BOOT	I	Boot mode control signal input terminal Not used
55	BTACT	O	Boot mode state display signal output terminal Not used
56	BST	I	Boot strap signal input from the system controller
57	MOD1	I	Operation mode setting terminal “L”: enhanced mode, “H”: normal mode Fixed at “H” in this set
58	MOD0	I	Operation mode setting terminal “L”: single chip mode, “H”: can not use Fixed at “L” in this set
59	EXLOCK	I	PLL lock error signal and data error flag input from the digital audio interface receiver
60	VDDI	—	Power supply terminal (+2.5V)
61	VSS	—	Ground terminal
62, 63	A17, A16	O	Address signal output terminal Not used
64 to 66	A15 to A13	O	Address signal output to the S-RAM
67	GP10	I	L/R sampling clock signal (44.1 kHz) input terminal
68	GP9	O	Read ready signal output to the system controller
69	GP8	I	Channel status bit 1 input from the digital audio interface receiver
70	VDDI	—	Power supply terminal (+2.5V)
71	VSS	—	Ground terminal
72 to 75	D15 to D12	I/O	Two-way data bus with the S-RAM
76	VDDE	—	Power supply terminal (+3.3V)
77 to 80	D11 to D8	I/O	Two-way data bus with the S-RAM
81	VSS	—	Ground terminal
82 to 85	A9, A12 to A10	O	Address signal output to the S-RAM
86	TDO	O	Simplicity emulation data output terminal Not used
87	TMS	I	Simplicity emulation data input start and end terminal Not used
88	XTRST	I	Simplicity emulation non-sync break signal input terminal Not used
89	TCK	I	Simplicity emulation clock signal input terminal Not used
90	TDI	I	Simplicity emulation data input terminal Not used
91	VSS	—	Ground terminal
92 to 97	A8 to A3	O	Address signal output to the S-RAM
98, 99	D7, D6	I/O	Two-way data bus with the S-RAM
100	VDDI	—	Power supply terminal (+2.5V)
101	VSS	—	Ground terminal
102 to 105	D5 to D2	I/O	Two-way data bus with the S-RAM
106	VDDE	—	Power supply terminal (+3.3V)
107, 108	D1, D0	I/O	Two-way data bus with the S-RAM
109, 110	A2, A1	O	Address signal output to the S-RAM
111	VSS	—	Ground terminal
112	A0	O	Address signal output to the S-RAM
113	PM	I	PLL initialize signal input from the system controller

Pin No.	Pin Name	I/O	Description
114, 115	SDI3, SDI4	I	Audio serial data input terminal Not used
116	SYNC	I	Sync/non-sync setting terminal “L”: sync, “H”: non-sync Fixed at “H” in this set
117 to 119	VSS	—	Ground terminal
120	VDDI	—	Power supply terminal (+2.5V)

• DIGITAL BOARD IC1601 MB90478PF-G-148-BND (SYSTEM CONTROLLER)

Pin No.	Pin Name	I/O	Description
1	DATA0	I	Audio serial data input from the digital audio interface receiver
2	GP9	I	Read ready signal input from the audio digital signal processor
3	BST	O	Boot strap signal output to the audio digital signal processor
4	HCS	O	Chip select signal output to the audio digital signal processor
5	HACN	I	Acknowledge signal input from the audio digital signal processor
6	XRST	O	System reset signal output to the audio digital signal processor "L": reset
7	PM	O	PLL initialize signal output to the audio digital signal processor
8	RST	O	System reset signal output to the D/A converter "L": reset
9	CLK	O	Serial data transfer clock signal output to the D/A converter
10	DATA OUT	I	Serial data input from the D/A converter
11	VSS	—	Ground terminal
12	LAT	O	Serial data latch pulse signal output to the D/A converter
13	DATA IN	O	Serial data output to the D/A converter
14	DATA	O	Serial data output to the tuner unit, function switch and electrical volume
15	CLK	O	Serial data transfer clock signal output to the tuner unit, function switch and electrical volume
16	LATCH	O	Serial data latch pulse signal output to the function switch and electrical volume
17	PCM1748 LAT	O	Serial data latch pulse signal output to the D/A converter
18	HDOUT	I	Serial data input from the audio digital signal processor
19	HDIN	O	Serial data output to the audio digital signal processor
20	HCLK	O	Serial data transfer clock signal output to the audio digital signal processor
21	GP12	O	Write signal output to the audio digital signal processor
22	AD RST	O	System reset signal output to the A/D converter "L": reset
23	VCC5	—	Power supply terminal (+3.3V)
24	D-POWER	O	Digital section power on/off control signal output terminal "H": power on
25	ANA/DIG	O	Analog/digital selection signal output terminal "L": analog, "H": digital
26	V-POWER	O	Video section power on/off control signal output terminal "H": power on
27	FLASH2	O	Flash programming signal output terminal
28	SP SWITCH/ FLASH1	I/O	Speaker switch input terminal "L": speaker on Flash programming signal output terminal
29	C/SB RY	O	Relay drive signal output terminal (for center/surround back speaker) "H": relay on
30	SPB RY	O	Relay drive signal output terminal (for front B speaker) "H": relay on
31	PCM SW	O	Not used
32	LRCK SW	O	Signal selection signal output terminal "L": boot strap signal, "H": L/R sampling clock signal
33	SCL	O	Serial data transfer clock signal output to the EEPROM
34	SDA	I/O	Two-way data bus with the EEPROM
35	AVCC	—	Power supply terminal (+3.3V) (for analog)
36	AVRH	I	Reference voltage (+3.3V) input terminal
37	AVSS	—	Ground terminal (for analog)
38, 39	A/D0, A/D1	I	Front panel key input terminal (A/D input)
40	RDS SIGNAL	I	RDS signal input from the tuner unit (STR-DB790: AEP and UK models only)
41	VERSION	I	Destination setting terminal
42	VSS	—	Ground terminal
43	DETECT	I	Voltage limit detection signal input terminal
44	MENU ENCODER A	I	Jog dial pulse input from the rotary encoder (A phase input) (for MENU)

Pin No.	Pin Name	I/O	Description
45	MENU ENCODER B	I	Jog dial pulse input from the rotary encoder (B phase input) (for MENU)
46	FUN LAT SW	O	Serial data latch pulse signal selection signal output terminal “L”: for electrical volume, “H”: for function switch
47	LIMITTER	O	Output voltage control signal output terminal
48	STOP	I	AC off detection signal input terminal
49, 50	MD0, MD1	O	Setting terminal for the CPU operation mode Fixed at “H” in this set
51	MD2	O	Setting terminal for the CPU operation mode Fixed at “L” in this set
52	RDS CLOCK	I	RDS interrupt clock signal input from the tuner unit (STR-DB790: AEP and UK models only)
53	RDS DATA	I	RDS serial data input from the tuner unit (STR-DB790: AEP and UK models only)
54	SIRCS	I	Sircs signal input terminal
55	HP DETECT	I	Headphone detection signal input terminal “H”: headphone is connected
56	POWER KEY	I	I/⏻ key input terminal “L”: power on
57 to 60	SW4 to SW1	O	Video selection signal output terminal
61	DIN	O	Serial data output to the fluorescent indicator tube driver
62	CLK	O	Serial data transfer clock signal output to the fluorescent indicator tube driver
63	FL STB	O	Strobe signal output to the fluorescent indicator tube driver
64	A1 OUT	O	Sircs signal output for CONTROL A1 II
65	A1 IN	I	Sircs signal input for CONTROL A1 II
66	POWER RELAY	O	Relay drive signal output terminal (for main power) “H”: relay on
67	PROTECTOR	I	Protect detection signal input from the protect circuit
68	HEADPHONE RELAY	O	Relay drive signal output terminal (for headphone) “H”: relay on
69	GROUPING SW	O	Data selection signal output terminal
70	REAR RELAY	O	Relay drive signal output terminal (for surround speaker) “H”: relay on
71	SW RELAY	O	Relay drive signal output terminal (for sub woofer) “H”: relay on
72	FRONT RELAY	O	Relay drive signal output (for front A speaker) “H”: relay on
73	TUNED	I	Tuned detection signal input from the tuner unit
74	STEREO	I	FM stereo detection signal input from the tuner unit
75	MUTE	O	Muting request control signal output to the tuner unit
76	DO	I	Serial data input from the tuner unit
77	RSTX	I	System reset signal input from the reset signal generator “L”: reset For several hundreds msec. after the power supply rises, “L” is input, then it changes to “H”
78	SLATCH	O	Serial data latch pulse signal output to the tuner unit
79	X1A	O	Sub system clock output terminal Not used
80	X0A	I	Sub system clock input terminal Not used
81	VSS	—	Ground terminal
82	X0	I	Main system clock input terminal (16 MHz)
83	X1	O	Main system clock output terminal (16 MHz)
84	VCC3	—	Power supply terminal (+3.3V)
85	FUNC (B)	I	Jog dial pulse input from the rotary encoder (B phase input) (for INPUT SELECTOR)
86	FUNC (A)	I	Jog dial pulse input from the rotary encoder (A phase input) (for INPUT SELECTOR)
87	+/- ENCODER A	I	Jog dial pulse input from the rotary encoder (A phase input) (for +/-)
88	+/- ENCODER B	I	Jog dial pulse input from the rotary encoder (B phase input) (for +/-)
89	VOL ENCODER A	I	Jog dial pulse input from the rotary encoder (A phase input) (for MASTER VOLUME)
90	VOL ENCODER B	I	Jog dial pulse input from the rotary encoder (B phase input) (for MASTER VOLUME)

Pin No.	Pin Name	I/O	Description
91, 92	SELECT1, SELECT2	O	Digital input selection signal output terminal
93	XMODE	O	System reset signal output to the digital audio interface receiver “L”: reset
94	CKSEL1	O	Output clock selection signal output to the digital audio interface receiver
95	CLK	O	Clock signal output to the digital audio interface receiver
96	CE	O	Chip enable signal output to the digital audio interface receiver
97	DI	O	Write data output to the digital audio interface receiver
98	DO	I	Read data input from the digital audio interface receiver
99	ERROR	I	PLL lock error signal and data error flag input from the digital audio interface receiver
100	XSTATE	I	Source clock selection monitor input from the digital audio interface receiver

SECTION 7 EXPLODED VIEWS

NOTE:

- -XX and -X mean standardized parts, so they may have some difference from the original one.
- Color Indication of Appearance Parts
Example:
KNOB, BALANCE (WHITE) . . . (RED)
 ↑ ↑
 Parts Color Cabinet's Color
- Abbreviation
AUS : Australian model KR : Korean model TW : Taiwan model
CH : Chinese model MY : Malaysia model
CND : Canadian model SP : Singapore model
- Color variation
SILVER : STR-DA1000ES/DB790: AEP, UK, Australian
GOLD : STR-DB790: Korean, Singapore, Malaysia, Taiwan, Chinese
BLACK : STR-DB790: AEP, UK, Australian

- Items marked "*" are not stocked since they are seldom required for routine service. Some delay should be anticipated when ordering these items.
- The mechanical parts with no reference number in the exploded views are not supplied.
- Accessories are given in the last of the electrical parts list.

<p>The components identified by mark \triangle or dotted line with mark \triangle are critical for safety. Replace only with part number specified.</p>
<p>Les composants identifiés par une marque \triangle sont critiques pour la sécurité. Ne les remplacer que par une pièce portant le numéro spécifié.</p>
<p>以阴影和 \triangle 标志来识别的零部件，在安全方面具有关键性，因此只能以规定号码的零部件来更换。</p>

7-1. CASE SECTION

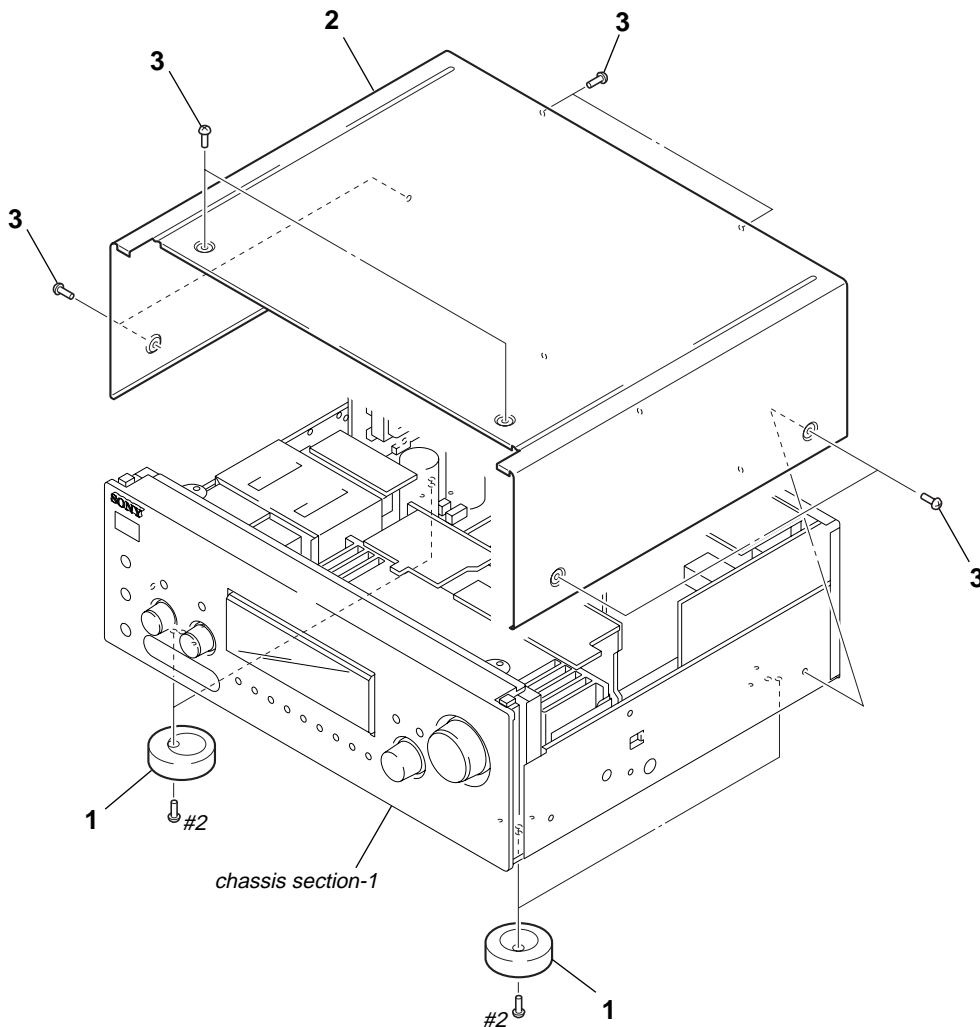

Ref. No.	Part No.	Description	Remark	Ref. No.	Part No.	Description	Remark
1	X-4953-883-2	FOOT ASSY		3	4-227-843-01	SCREW (TP), FLAT HEAD (BLACK)	
2	4-248-594-01	CASE (414535) (SILVER)		3	4-227-843-31	SCREW (TP), FLAT HEAD (SILVER, GOLD)	
2	4-248-594-21	CASE (414535) (GOLD)		#2	7-685-885-09	SCREW +BVTT 4X16 (S)	
2	4-900-512-02	CASE (414535) (BLACK)					

7-2. CHASSIS SECTION-1

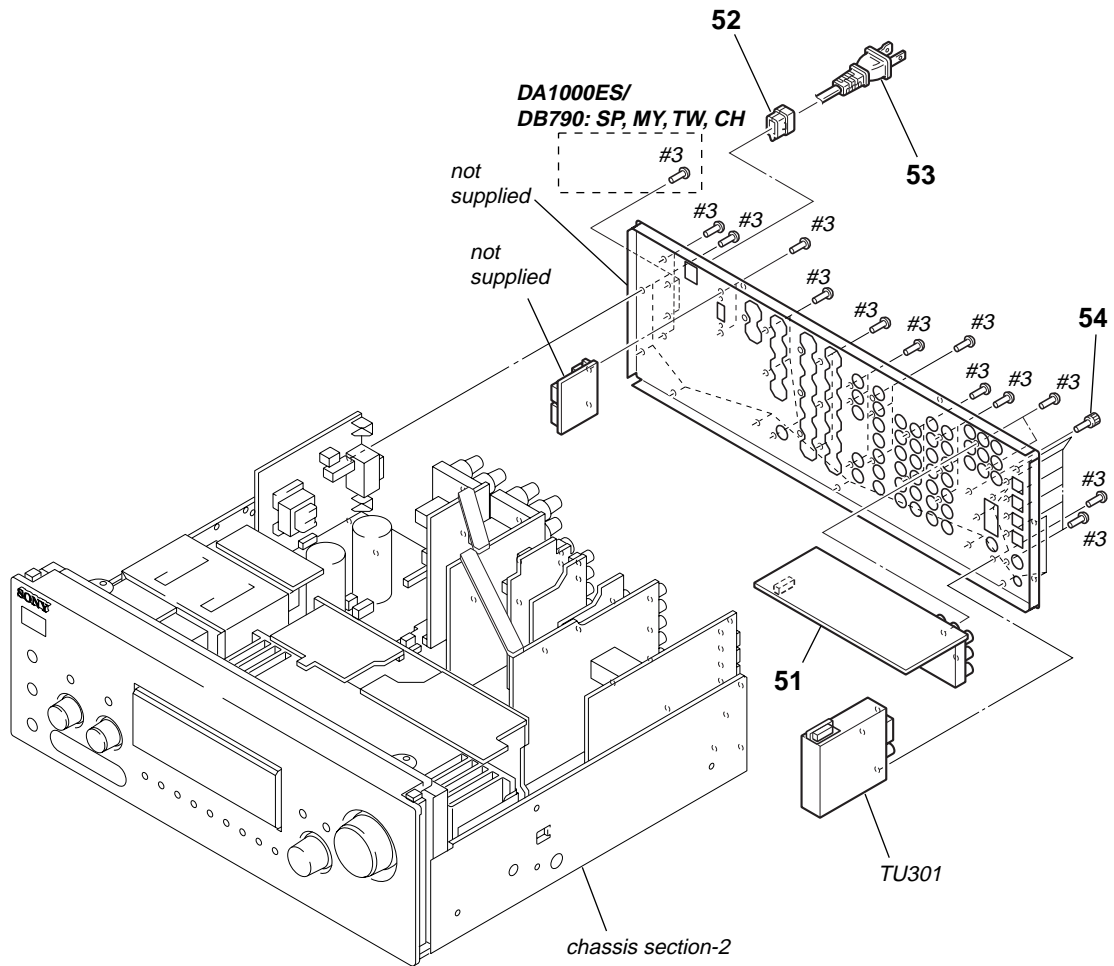

<p>The components identified by mark \triangle or dotted line with mark \triangle are critical for safety. Replace only with part number specified.</p>	<p>Les composants identifiés par une marque \triangle sont critiques pour la sécurité. Ne les remplacer que par une pièce portant le numéro spécifié.</p>	<p>以阴影和 \triangle 标志来识别的零部件，在安全方面具有关键性。因此只能以规定号码的零部件来更换。</p>
---	--	---

Ref. No.	Part No.	Description	Remark	Ref. No.	Part No.	Description	Remark
51	A-4733-546-A	COMP-V BOARD, COMPLETE (DB790)		\triangle 53	1-783-820-11	CORD, POWER (US)	
51	A-4733-521-A	COMP-V BOARD, COMPLETE (DA1000ES)		\triangle 53	1-827-597-41	CORD, POWER (TW)	
* 52	3-703-244-00	BUSHING (2104), CORD		54	4-947-010-01	SCREW, FEEDER FIXED	
\triangle 53	1-696-847-21	CORD, POWER (AUS)		TU301	1-693-577-21	TUNER (DA1000ES)	
\triangle 53	1-769-079-22	CORD, POWER (KR)		TU301	1-693-578-21	TUNER (DB790: AEP, UK)	
\triangle 53	1-769-743-11	CORD, POWER (CND)		TU301	1-693-580-23	TUNER (DB790: SP, MY, TW, KR, AUS, CH)	
\triangle 53	1-777-071-23	CORD, POWER (AEP, UK, SP, MY)		#3	7-685-646-79	SCREW +BVTX 3X8 TYPE IT-3	
\triangle 53	1-782-464-22	CORD, POWER (CH)					

7-3. CHASSIS SECTION-2

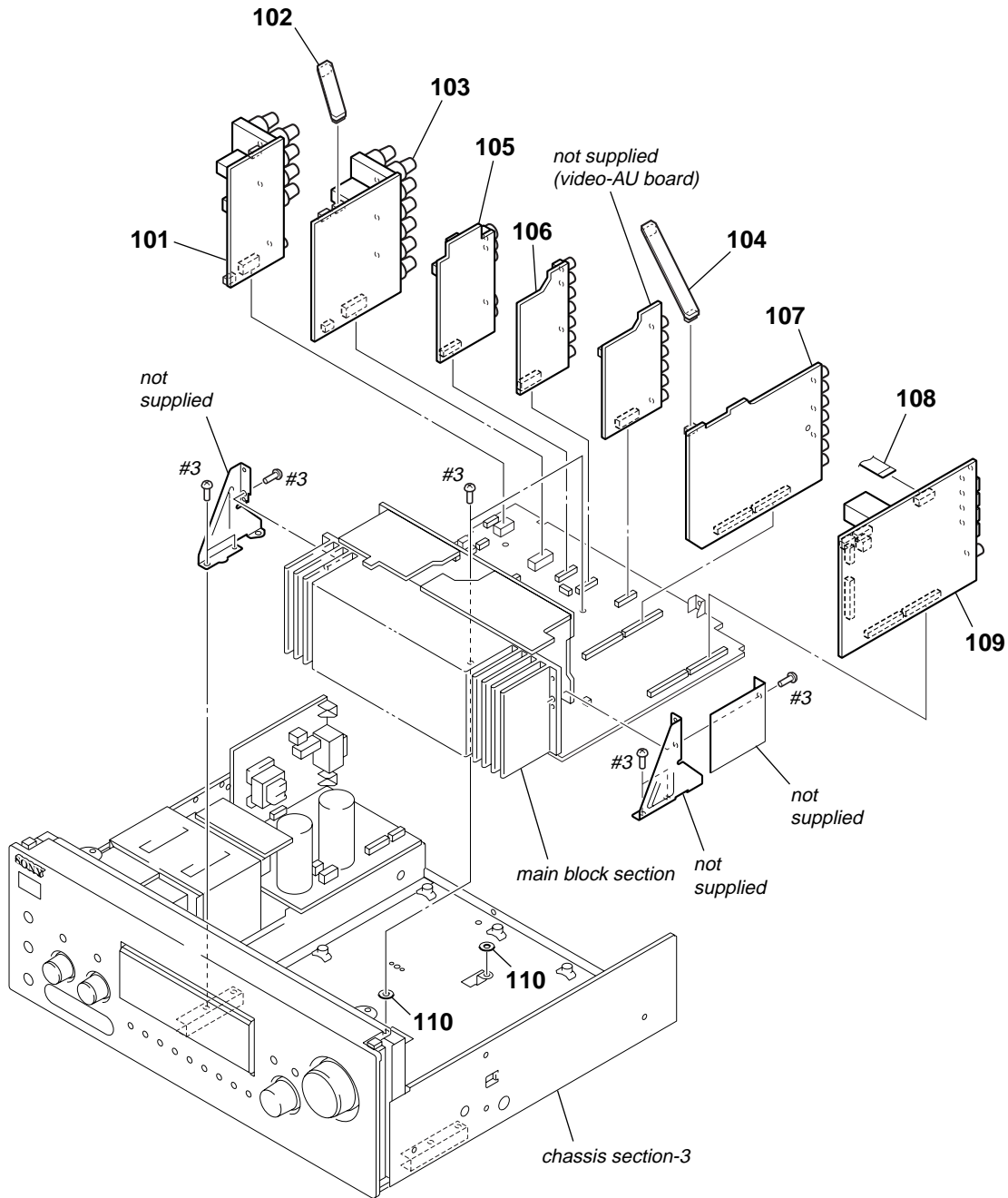

Ref. No.	Part No.	Description	Remark	Ref. No.	Part No.	Description	Remark
101	1-688-637-11	SP-B BOARD		108	1-769-938-11	WIRE (FLAT TYPE) (11 CORE)	
102	1-689-784-11	STAY4 BOARD		108	1-773-002-11	WIRE (FLAT TYPE) (15 CORE)	
103	1-688-636-11	SP-A BOARD				(DB790: AEP, UK)	
104	1-689-748-11	STAY3 BOARD		109	A-4733-508-A	DIGITAL BOARD, COMPLETE (DA1000ES)	
105	A-4733-530-A	S-VIDEO BOARD, COMPLETE (DA1000ES)		109	A-4733-536-A	DIGITAL BOARD, COMPLETE	
						(DB790: SP, MY, TW, KR, AUS, CH)	
105	A-4733-550-A	S-VIDEO BOARD, COMPLETE (DB790)		109	A-4733-576-A	DIGITAL BOARD, COMPLETE (DB790: AEP, UK)	
106	1-688-645-11	VIDEO BOARD					
107	A-4733-570-A	AU-IN BOARD, COMPLETE		110	4-971-099-01	WASHER (P)	
		(DB790: AEP, UK, AUS)		#3	7-685-646-79	SCREW +BVTP 3X8 TYPE2 IT-3	
107	A-4733-528-A	AU-IN BOARD, COMPLETE (DA1000ES)					
107	A-4733-548-A	AU-IN BOARD, COMPLETE					
		(DB790: SP, MY, TW, KR, CH)					

7-4. MAIN BLOCK SECTION

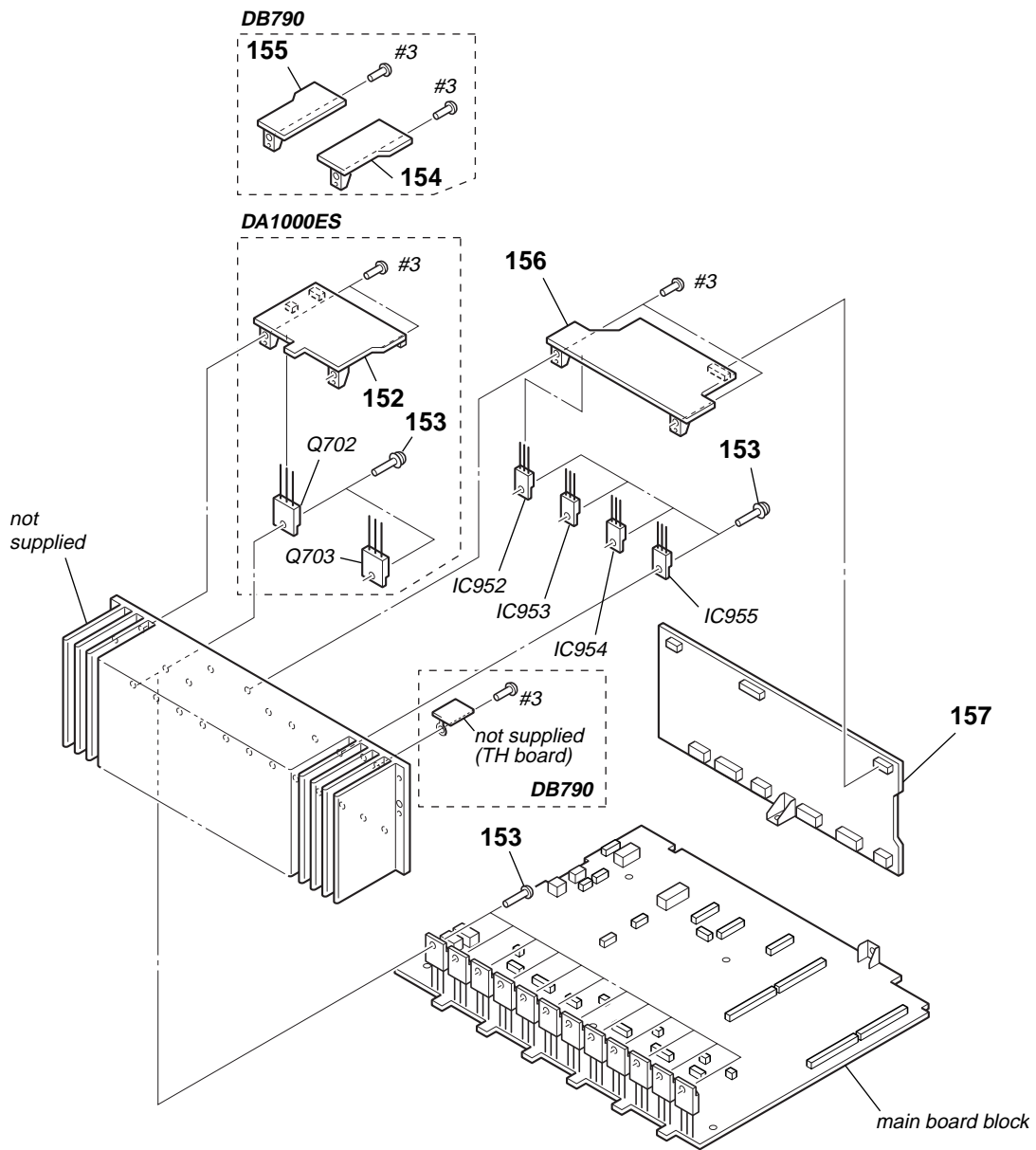

Ref. No.	Part No.	Description	Remark	Ref. No.	Part No.	Description	Remark
152	A-4733-518-A	SBL BOARD, COMPLETE (DA1000ES)		157	A-4733-539-A	A-CLASS BOARD, COMPLETE (DB790: SP, MY, TW, KR, CH)	
153	3-905-609-11	SCREW (TRANSISTOR)		IC952	8-759-231-53	IC TA7805S	
154	1-689-177-11	STAY BOARD (DB790)		IC953	8-759-231-53	IC TA7805S	
155	1-689-747-11	STAY2 BOARD (DB790)		IC954	8-759-245-87	IC TA79015S	
156	A-4733-517-A	DC2 BOARD, COMPLETE (DA1000ES)		IC955	8-759-231-59	IC TA7815S	
156	A-4733-543-A	DC2 BOARD, COMPLETE (DB790: SP, MY, TW, KR, CH)		Q702	6-702-390-01	IC MN2488-OPY-MK (DA1000ES)	
156	A-4733-574-A	DC2 BOARD, COMPLETE (DB790: AEP, UK, AUS)		Q703	6-702-391-01	IC MP1620-OPY-MK (DA1000ES)	
157	A-4733-467-A	A-CLASS BOARD, COMPLETE (DB790: AEP, UK, AUS)		#3	7-685-646-79	SCREW +BVTP 3X8 TYPE2 IT-3	
157	A-4733-513-A	A-CLASS BOARD, COMPLETE (DA1000ES)					

7-5. MAIN BOARD BLOCK

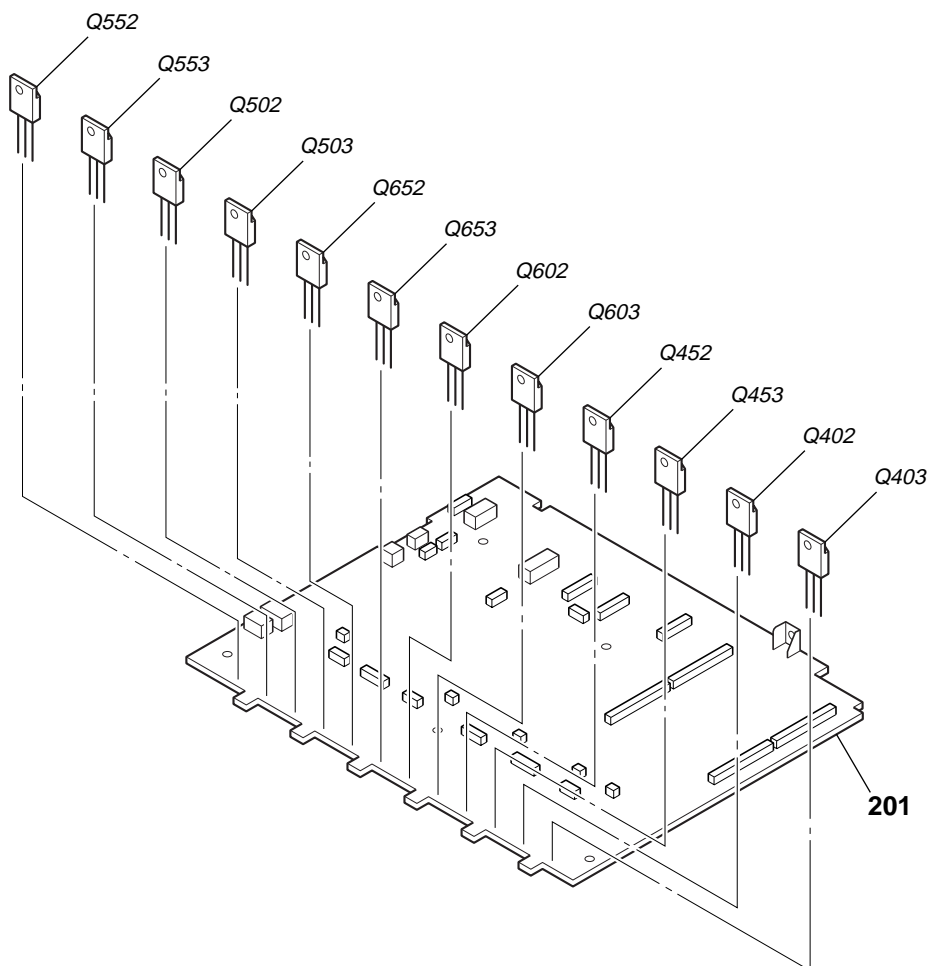

Ref. No.	Part No.	Description	Remark	Ref. No.	Part No.	Description	Remark
201	A-4733-533-A	MAIN BOARD, COMPLETE (DA1000ES)		Q502	6-702-390-01	IC MN2488-OPY-MK	
201	A-4733-553-A	MAIN BOARD, COMPLETE (DB790: SP, MY, TW, KR, CH)		Q503	6-702-391-01	IC MP1620-OPY-MK	
201	A-4733-568-A	MAIN BOARD, COMPLETE (DB790: AEP, UK, AUS)		Q552	6-702-390-01	IC MN2488-OPY-MK	
Q402	6-702-390-01	IC MN2488-OPY-MK		Q553	6-702-391-01	IC MP1620-OPY-MK	
Q403	6-702-391-01	IC MP1620-OPY-MK		Q602	6-702-390-01	IC MN2488-OPY-MK	
Q452	6-702-390-01	IC MN2488-OPY-MK		Q603	6-702-391-01	IC MP1620-OPY-MK	
Q453	6-702-391-01	IC MP1620-OPY-MK		Q652	6-702-390-01	IC MN2488-OPY-MK	
				Q653	6-702-391-01	IC MP1620-OPY-MK	

7-6. CHASSIS SECTION-3

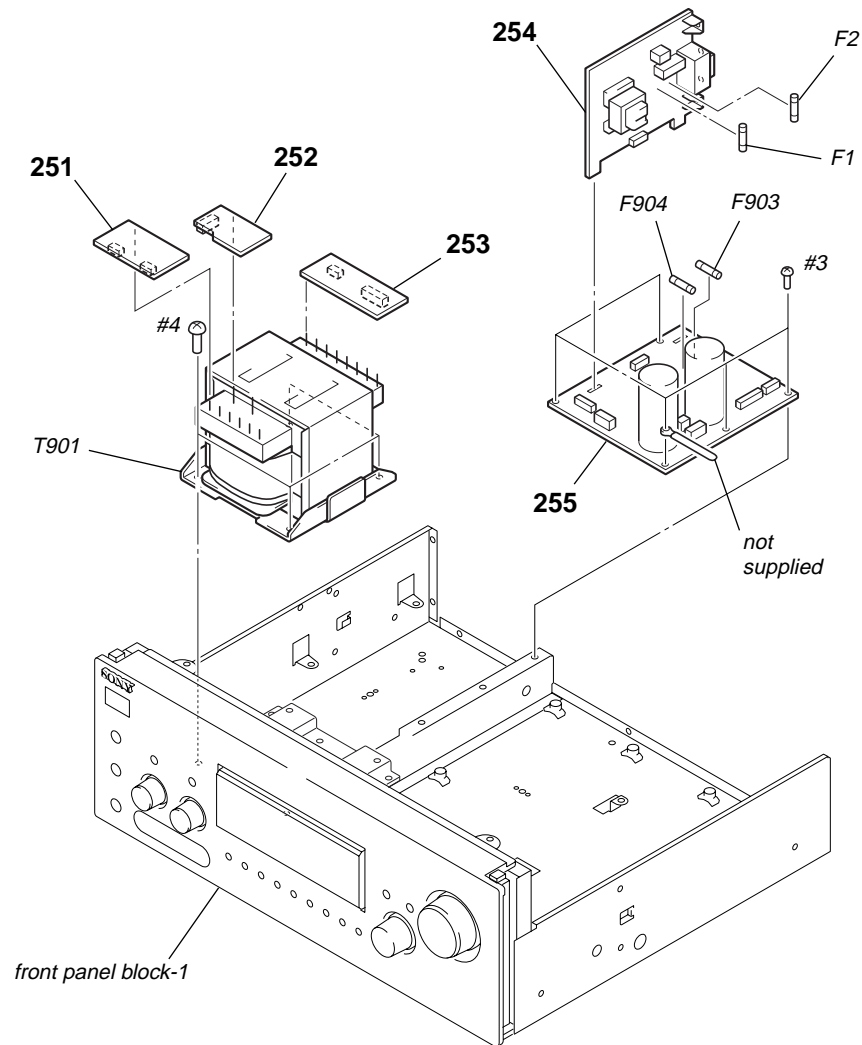

The components identified by mark \triangle or dotted line with mark \triangle are critical for safety. Replace only with part number specified.

Les composants identifiés par une marque \triangle sont critiques pour la sécurité. Ne les remplacer que par une pièce portant le numéro spécifié.

以阴影和 \triangle 标志来识别的零部件，在安全方面具有关键性。因此只能以规定号码的零部件来更换。

Ref. No.	Part No.	Description	Remark	Ref. No.	Part No.	Description	Remark
251	1-689-176-11	SEC3 BOARD		\triangle F903	1-532-504-51	FUSE (4A/250V) (DB790)	
252	1-689-173-11	PRI BOARD		\triangle F903	1-576-108-11	FUSE (4A/125V) (DA1000ES)	
253	1-689-174-11	SEC1 BOARD		\triangle F904	1-532-504-51	FUSE (4A/250V) (DB790)	
254	1-688-632-11	AC BOARD		\triangle F904	1-576-108-11	FUSE (4A/125V) (DA1000ES)	
255	1-688-633-11	DC1 BOARD		\triangle T901	1-439-800-11	TRANSFORMER, POWER (DB790: CH)	
\triangle F1	1-532-504-51	FUSE (4A/250V) (DB790: AEP, UK, SP, MY, KR, AUS, CH)		\triangle T901	1-439-801-11	TRANSFORMER, POWER (DB790: TW)	
\triangle F1	1-533-312-11	FUSE, GLASS CYLINDRICAL (DIA.5) (10A/125V) (DA1000ES/DB790: TW)		\triangle T901	1-439-802-11	TRANSFORMER, POWER (DA1000ES)	
\triangle F2	1-532-464-51	FUSE (T2.5AL/250V) (DB790: SP, MY)		\triangle T901	1-439-803-11	TRANSFORMER, POWER (DB790: AEP, UK, SP, MY, KR, AUS)	
\triangle F2	1-533-312-11	FUSE, GLASS CYLINDRICAL (DIA.5) (10A/125V) (DA1000ES)		#3	7-685-646-79	SCREW +BVTP 3X8 TYPE2 IT-3	
				#4	7-685-881-09	SCREW +BVTT 4X8 (S)	

7-7. FRONT PANEL BLOCK-1

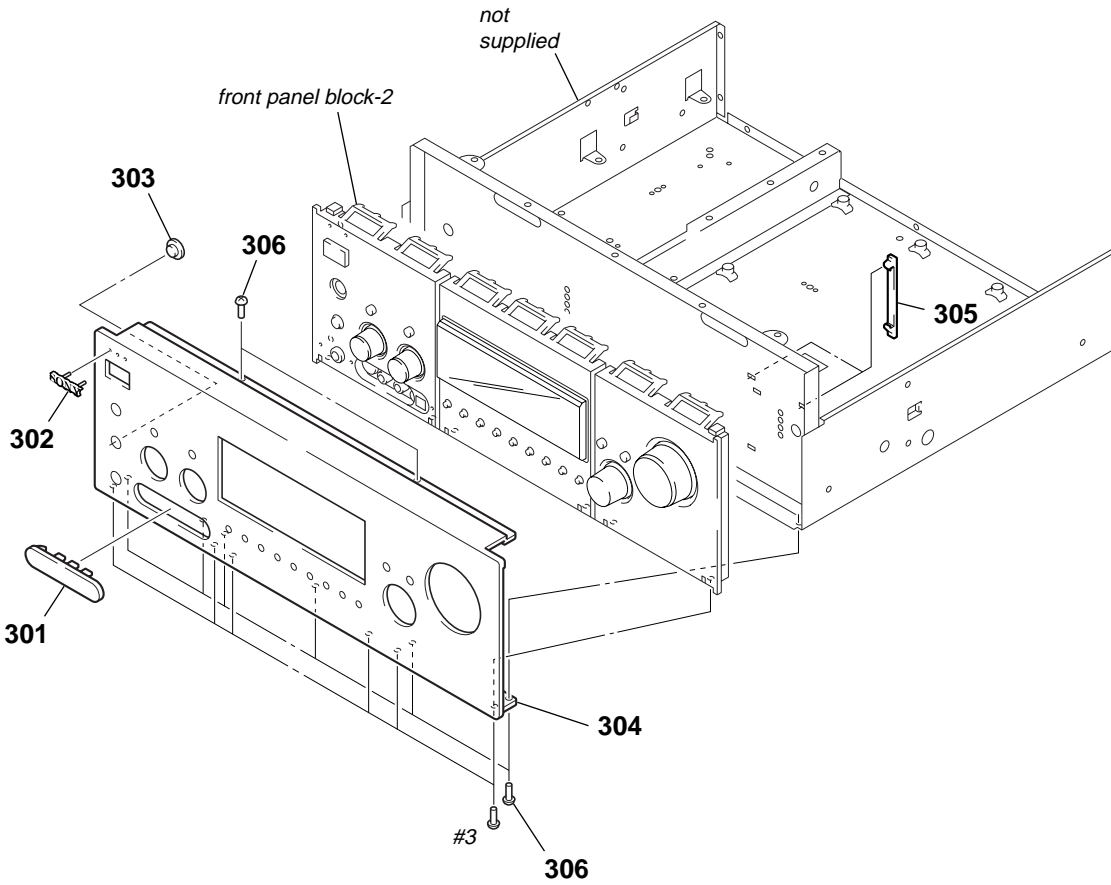

Ref. No.	Part No.	Description	Remark	Ref. No.	Part No.	Description	Remark
301	X-4955-963-2	LID ASSY (BLACK)		304	4-245-444-11	PANEL, FRONT (DB790: SILVER)	
301	X-4955-967-1	LID ASSY (GOLD)		304	4-245-444-21	PANEL, FRONT (DB790: GOLD)	
301	X-4955-968-2	LID ASSY (SILVER)		304	4-245-444-31	PANEL, FRONT (DA1000ES)	
302	4-240-858-01	EMBLEM (5-A), SONY (BLACK)		305	3-064-084-01	CLAMP (FCR-60), FLAT	
302	4-240-858-11	EMBLEM (5-A), SONY (GOLD)		306	3-704-515-21	SCREW (BV/RING) (BLACK)	
302	4-240-858-21	EMBLEM (5-A), SONY (SILVER)		306	3-704-515-31	SCREW (BV/RING) (SILVER, GOLD)	
303	X-4953-000-1	WINDOW ASSY, REMOTE CONTROL		#3	7-685-646-79	SCREW +BVTP 3X8 TYPE2 IT-3	
304	4-245-444-01	PANEL, FRONT (DB790: BLACK)					

7-8. FRONT PANEL BLOCK-2

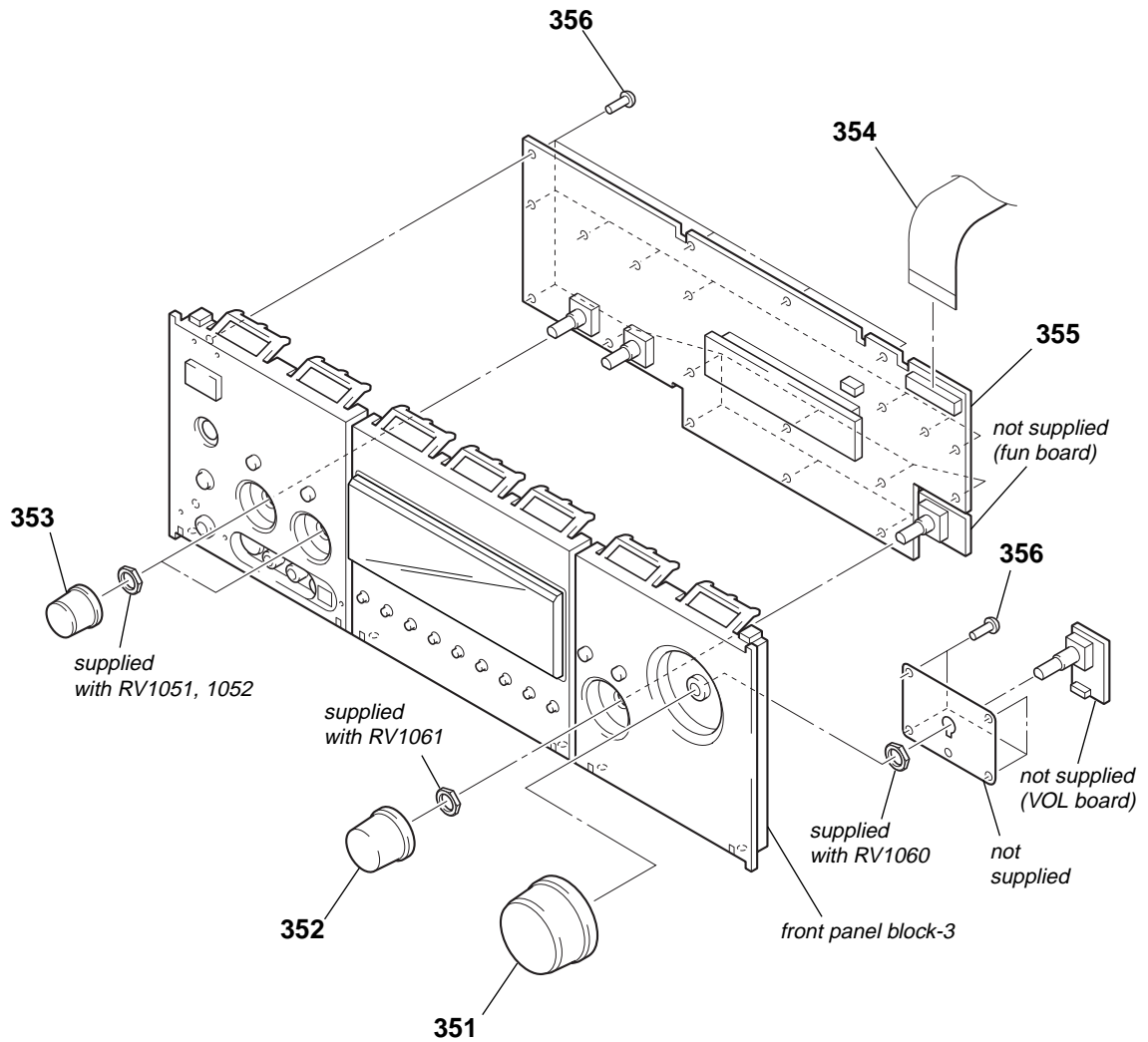

Ref. No.	Part No.	Description	Remark	Ref. No.	Part No.	Description	Remark
351	4-240-507-01	KNOB (VOL) (BLACK)		353	4-245-437-01	KNOB (MENU) (BLACK)	
351	X-4953-671-1	KNOB (VOL-E) ASSY (GOLD)		353	4-245-437-21	KNOB (MENU) (GOLD)	
351	X-4953-672-1	KNOB (VOL-E) ASSY (SILVER)		353	4-245-437-31	KNOB (MENU) (SILVER)	
352	4-232-569-01	KNOB (FN DE9) (BLACK)		354	1-773-270-11	WIRE (FLAT TYPE) (27 CORE)	
352	4-232-569-11	KNOB (FN DE9) (GOLD)		355	A-4733-524-A	DISPLAY BOARD, COMPLETE	
352	4-232-569-21	KNOB (FN DE9) (SILVER)		356	4-951-620-01	SCREW (2.6X8), +BVTP	

7-9. FRONT PANEL BLOCK-3

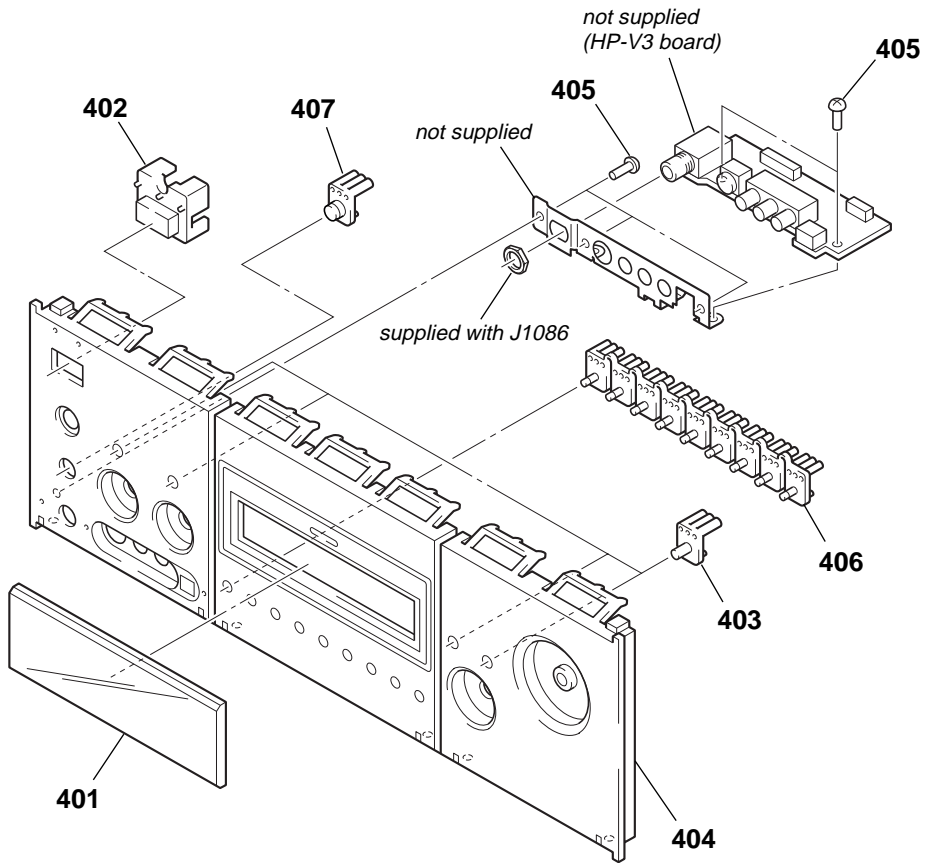

Ref. No.	Part No.	Description	Remark	Ref. No.	Part No.	Description	Remark
401	4-245-438-01	PLATE, INDICATION (BLACK)		404	4-245-430-11	BASE, PANEL (SILVER)	
401	4-245-438-11	PLATE, INDICATION (SILVER)		404	4-245-430-21	BASE, PANEL (GOLD)	
402	4-998-592-01	BUTTON (POWER) (BLACK)		405	4-951-620-01	SCREW (2.6X8), +BVTP	
402	4-998-592-12	BUTTON (POWER) (GOLD)		406	4-245-435-01	BUTTON (MODE) (BLACK)	
402	4-998-592-31	BUTTON (POWER) (SILVER)		406	4-245-435-21	BUTTON (MODE) (GOLD)	
403	4-245-436-01	BUTTON (MENU) (BLACK)		406	4-245-435-31	BUTTON (MODE) (SILVER)	
403	4-245-436-21	BUTTON (MENU) (GOLD)		407	4-245-434-01	BUTTON (SP) (BLACK)	
403	4-245-436-31	BUTTON (MENU) (SILVER)		407	4-245-434-21	BUTTON (SP) (GOLD)	
404	4-245-430-01	BASE, PANEL (BLACK)		407	4-245-434-31	BUTTON (SP) (SILVER)	

SECTION 8 ELECTRICAL PARTS LIST

4/8 SW

A-CLASS

NOTE:

- Due to standardization, replacements in the parts list may be different from the parts specified in the diagrams or the components used on the set.
- -XX and -X mean standardized parts, so they may have some difference from the original one.
- RESISTORS
All resistors are in ohms.
METAL: Metal-film resistor.
METAL OXIDE: Metal oxide-film resistor.
F: nonflammable
- Abbreviation
AUS : Australian model KR : Korean model SP : Singapore model
CND : Canadian model MY : Malaysia model TW : Taiwan model
CH : Chinese model
- Items marked “*” are not stocked since they are seldom required for routine service. Some delay should be anticipated when ordering these items.
- SEMICONDUCTORS
In each case, u: μ , for example:
uA. . : μ A. . uPA. . : μ PA. .
uPB. . : μ PB. . uPC. . : μ PC. .
uPD. . : μ PD. .
- CAPACITORS
uF: μ F
- COILS
uH: μ H

The components identified by mark Δ or dotted line with mark Δ are critical for safety. Replace only with part number specified.

Les composants identifiés par une marque Δ sont critiques pour la sécurité. Ne les remplacer que par une pièce portant le numéro spécifié.

以阴影和 Δ 标志来识别的零部件，在安全方面具有关键性。因此只能以规定号码的零部件来更换。

When indicating parts by reference number, please include the board.

Ref. No.	Part No.	Description	Remark	Ref. No.	Part No.	Description	Remark
		4/8 SW BOARD *****		C2102	1-128-869-11	ELECT 22uF 20% 63V (DB790: SP, MY, TW, KR, CH)	
		< CONNECTOR >		C2102	1-135-768-11	ELECT 22uF 63V (DB790: AEP, UK, AUS)	
* CN901	1-564-242-00	PIN, CONNECTOR (3.96mm PITCH) 5P		C2104	1-126-934-11	ELECT 220uF 20% 16V (DA1000ES)	
CN902	1-785-101-11	PIN, CONNECTOR (3.96mm PITCH) 3P		C2104	1-127-719-11	ELECT 220uF 20% 16V (DB790: SP, MY, TW, KR, CH)	
		< SWITCH >		C2104	1-135-710-11	ELECT 220uF 16V (DB790: AEP, UK, AUS)	
S901	1-771-876-11	SWITCH, POWER (IMPEDANCE SELECTOR)		C2105	1-126-940-11	ELECT 330uF 20% 25V (DA1000ES)	
		*****		C2105	1-128-846-11	ELECT 330uF 20% 25V (DB790: SP, MY, TW, KR, CH)	
	A-4733-467-A	A-CLASS BOARD, COMPLETE (DB790: AEP, UK, AUS)		C2105	1-135-683-11	ELECT 330uF 25V (DB790: AEP, UK, AUS)	
	A-4733-513-A	A-CLASS BOARD, COMPLETE (DA1000ES)					
	A-4733-539-A	A-CLASS BOARD, COMPLETE (DB790: SP, MY, TW, KR, CH)		C2106	1-102-230-00	CERAMIC 4PF 0.25PF 500V	
		*****		C2107	1-102-233-00	CERAMIC 33PF 10% 500V	
		< CAPACITOR >		C2108	1-137-383-11	MYLAR 220PF 5% 100V	
C2001	1-137-505-11	FILM 220PF 5% 100V		C2109	1-137-389-11	MYLAR 0.0022uF 5% 100V	
C2002	1-128-551-11	ELECT 22uF 20% 63V (DA1000ES)		C2110	1-137-389-11	MYLAR 0.0022uF 5% 100V	
C2002	1-128-869-11	ELECT 22uF 20% 63V (DB790: SP, MY, TW, KR, CH)		C2201	1-137-505-11	FILM 220PF 5% 100V	
C2002	1-135-768-11	ELECT 22uF 63V (DB790: AEP, UK, AUS)		C2202	1-128-551-11	ELECT 22uF 20% 63V (DA1000ES)	
C2004	1-126-934-11	ELECT 220uF 20% 16V (DA1000ES)		C2202	1-128-869-11	ELECT 22uF 20% 63V (DB790: SP, MY, TW, KR, CH)	
C2004	1-127-719-11	ELECT 220uF 20% 16V (DB790: SP, MY, TW, KR, CH)		C2202	1-135-768-11	ELECT 22uF 63V (DB790: AEP, UK, AUS)	
C2004	1-135-710-11	ELECT 220uF 16V (DB790: AEP, UK, AUS)		C2204	1-126-934-11	ELECT 220uF 20% 16V (DA1000ES)	
C2005	1-126-940-11	ELECT 330uF 20% 25V (DA1000ES)		C2204	1-127-719-11	ELECT 220uF 20% 16V (DB790: SP, MY, TW, KR, CH)	
C2005	1-128-846-11	ELECT 330uF 20% 25V (DB790: SP, MY, TW, KR, CH)		C2204	1-135-710-11	ELECT 220uF 16V (DB790: AEP, UK, AUS)	
C2005	1-135-683-11	ELECT 330uF 25V (DB790: AEP, UK, AUS)		C2205	1-126-940-11	ELECT 330uF 20% 25V (DA1000ES)	
C2006	1-102-230-00	CERAMIC 4PF 0.25PF 500V		C2205	1-128-846-11	ELECT 330uF 20% 25V (DB790: SP, MY, TW, KR, CH)	
C2007	1-102-233-00	CERAMIC 33PF 10% 500V		C2205	1-135-683-11	ELECT 330uF 25V (DB790: AEP, UK, AUS)	
C2008	1-137-383-11	MYLAR 220PF 5% 100V					
C2009	1-137-389-11	MYLAR 0.0022uF 5% 100V		C2206	1-102-230-00	CERAMIC 4PF 0.25PF 500V	
C2010	1-137-389-11	MYLAR 0.0022uF 5% 100V		C2207	1-102-233-00	CERAMIC 33PF 10% 500V	
C2101	1-137-505-11	FILM 220PF 5% 100V		C2208	1-137-383-11	MYLAR 220PF 5% 100V	
C2102	1-128-551-11	ELECT 22uF 20% 63V (DA1000ES)		C2209	1-137-389-11	MYLAR 0.0022uF 5% 100V	
				C2210	1-137-389-11	MYLAR 0.0022uF 5% 100V	
				C2301	1-137-505-11	FILM 220PF 5% 100V	

STR-DA1000ES/DB790

Ver 1.1

A-CLASS

Ref. No.	Part No.	Description	Remark	Ref. No.	Part No.	Description	Remark
C2302	1-128-551-11	ELECT	22uF 20% 63V (DA1000ES)	C2505	1-128-846-11	ELECT	330uF 20% 25V (DB790: SP, MY, TW, KR, CH)
C2302	1-128-869-11	ELECT	22uF 20% 63V (DB790: SP, MY, TW, KR, CH)	C2505	1-135-683-11	ELECT	330uF 25V (DB790: AEP, UK, AUS)
C2302	1-135-768-11	ELECT	22uF 63V (DB790: AEP, UK, AUS)	C2506	1-102-230-00	CERAMIC	4PF 0.25PF 500V
C2304	1-126-934-11	ELECT	220uF 20% 16V (DA1000ES)	C2507	1-102-233-00	CERAMIC	33PF 10% 500V
C2304	1-127-719-11	ELECT	220uF 20% 16V (DB790: SP, MY, TW, KR, CH)	C2508	1-137-383-11	MYLAR	220PF 5% 100V
C2304	1-135-710-11	ELECT	220uF 16V (DB790: AEP, UK, AUS)	C2509	1-137-389-11	MYLAR	0.0022uF 5% 100V
C2305	1-126-940-11	ELECT	330uF 20% 25V (DA1000ES)	C2510	1-137-389-11	MYLAR	0.0022uF 5% 100V
C2305	1-128-846-11	ELECT	330uF 20% 25V (DB790: SP, MY, TW, KR, CH)	C2601	1-128-562-11	ELECT	47uF 20% 100V (DA1000ES)
C2305	1-135-683-11	ELECT	330uF 25V (DB790: AEP, UK, AUS)	C2601	1-135-729-51	ELECT	47uF 100V (DB790)
C2306	1-102-230-00	CERAMIC	4PF 0.25PF 500V	C2602	1-128-562-11	ELECT	47uF 20% 100V (DA1000ES)
C2307	1-102-233-00	CERAMIC	33PF 10% 500V	C2602	1-135-729-51	ELECT	47uF 100V (DB790)
C2308	1-137-383-11	MYLAR	220PF 5% 100V	C2603	1-128-581-11	ELECT	4.7uF 20% 100V (DA1000ES)
C2309	1-137-389-11	MYLAR	0.0022uF 5% 100V	C2603	1-128-881-11	ELECT	4.7uF 20% 100V (DB790: SP, MY, TW, KR, CH)
C2310	1-137-389-11	MYLAR	0.0022uF 5% 100V	C2603	1-135-723-11	ELECT	4.7uF 100V (DB790: AEP, UK, AUS)
C2401	1-137-505-11	FILM	220PF 5% 100V	C2605	1-128-560-11	ELECT	22uF 20% 100V (DA1000ES)
C2402	1-128-551-11	ELECT	22uF 20% 63V (DA1000ES)	C2605	1-128-883-11	ELECT	22uF 20% 100V (DB790: SP, MY, TW, KR, CH)
C2402	1-128-869-11	ELECT	22uF 20% 63V (DB790: SP, MY, TW, KR, CH)	C2605	1-135-727-11	ELECT	22uF 100V (DB790: AEP, UK, AUS)
C2402	1-135-768-11	ELECT	22uF 63V (DB790: AEP, UK, AUS)	C2606	1-128-560-11	ELECT	22uF 20% 100V (DA1000ES)
C2404	1-126-934-11	ELECT	220uF 20% 16V (DA1000ES)	C2606	1-128-883-11	ELECT	22uF 20% 100V (DB790: SP, MY, TW, KR, CH)
C2404	1-127-719-11	ELECT	220uF 20% 16V (DB790: SP, MY, TW, KR, CH)	C2606	1-135-727-11	ELECT	22uF 100V (DB790: AEP, UK, AUS)
C2404	1-135-710-11	ELECT	220uF 16V (DB790: AEP, UK, AUS)	< CONNECTOR >			
C2405	1-126-940-11	ELECT	330uF 20% 25V (DA1000ES)	CN2001	1-770-412-11	CONNECTOR, BOARD TO BOARD 6P	
C2405	1-128-846-11	ELECT	330uF 20% 25V (DB790: SP, MY, TW, KR, CH)	CN2002	1-770-412-11	CONNECTOR, BOARD TO BOARD 6P	
C2405	1-135-683-11	ELECT	330uF 25V (DB790: AEP, UK, AUS)	CN2003	1-778-226-21	CONNECTOR, BOARD TO BOARD 6P	
C2406	1-102-230-00	CERAMIC	4PF 0.25PF 500V	CN2004	1-778-226-21	CONNECTOR, BOARD TO BOARD 6P	
C2407	1-102-233-00	CERAMIC	33PF 10% 500V	CN2005	1-770-010-21	CONNECTOR, BOARD TO BOARD 4P	
C2408	1-137-383-11	MYLAR	220PF 5% 100V	CN2101	1-770-407-11	CONNECTOR, BOARD TO BOARD 12P	
C2409	1-137-389-11	MYLAR	0.0022uF 5% 100V	CN2201	1-770-412-11	CONNECTOR, BOARD TO BOARD 6P	
C2410	1-137-389-11	MYLAR	0.0022uF 5% 100V	CN2301	1-770-406-11	CONNECTOR, BOARD TO BOARD 10P	
C2501	1-137-505-11	FILM	220PF 5% 100V	CN2401	1-770-407-11	CONNECTOR, BOARD TO BOARD 12P	
C2502	1-128-551-11	ELECT	22uF 20% 63V (DA1000ES)	< DIODE >			
C2502	1-128-869-11	ELECT	22uF 20% 63V (DB790: SP, MY, TW, KR, CH)	D2001	8-719-109-89	DIODE RD5.6ESB2	
C2502	1-135-768-11	ELECT	22uF 63V (DB790: AEP, UK, AUS)	D2101	8-719-109-89	DIODE RD5.6ESB2	
C2504	1-126-934-11	ELECT	220uF 20% 16V (DA1000ES)	D2201	8-719-109-89	DIODE RD5.6ESB2	
C2504	1-127-719-11	ELECT	220uF 20% 16V (DB790: SP, MY, TW, KR, CH)	D2301	8-719-109-89	DIODE RD5.6ESB2	
C2504	1-135-710-11	ELECT	220uF 16V (DB790: AEP, UK, AUS)	D2401	8-719-109-89	DIODE RD5.6ESB2	
C2505	1-126-940-11	ELECT	330uF 20% 25V (DA1000ES)	D2501	8-719-109-89	DIODE RD5.6ESB2	
				D2601	8-719-947-84	DIODE MTZJ-T-72-24D	
				D2603	8-719-991-33	DIODE 1SS133T-77	
				D2604	8-719-991-33	DIODE 1SS133T-77	
				< TRANSISTOR >			
				Q2001	8-729-045-15	TRANSISTOR 2SC5169-FG	

A-CLASS

Ref. No.	Part No.	Description	Remark	Ref. No.	Part No.	Description	Remark
Q2003	8-729-119-78	TRANSISTOR	2SC2785-HFE	R2108	1-247-843-11	CARBON	3.3K 5% 1/4W
Q2004	8-729-199-22	TRANSISTOR	2SA992-FA	R2109	1-249-560-31	CARBON	2.2K 5% 1/4W
Q2005	8-729-021-74	TRANSISTOR	2SA949-OY	R2110	1-249-594-31	CARBON	56K 5% 1/4W
Q2006	8-729-021-73	TRANSISTOR	2SC2229-OY	R2111	1-249-441-11	CARBON	100K 5% 1/4W
Q2101	8-729-045-15	TRANSISTOR	2SC5169-FG	R2112	1-249-441-11	CARBON	100K 5% 1/4W
Q2103	8-729-119-78	TRANSISTOR	2SC2785-HFE	△R2113	1-249-413-11	CARBON	470 5% 1/4W F
Q2104	8-729-199-22	TRANSISTOR	2SA992-FA	△R2114	1-249-406-11	CARBON	120 5% 1/4W F
Q2105	8-729-021-74	TRANSISTOR	2SA949-OY	△R2115	1-249-406-11	CARBON	120 5% 1/4W F
Q2106	8-729-021-73	TRANSISTOR	2SC2229-OY	R2116	1-249-435-11	CARBON	33K 5% 1/4W
Q2201	8-729-045-15	TRANSISTOR	2SC5169-FG	R2119	1-249-407-11	CARBON	150 5% 1/4W
Q2203	8-729-119-78	TRANSISTOR	2SC2785-HFE	R2201	1-249-417-11	CARBON	1K 5% 1/4W
Q2204	8-729-199-22	TRANSISTOR	2SA992-FA	R2202	1-249-438-11	CARBON	56K 5% 1/4W
Q2205	8-729-021-74	TRANSISTOR	2SA949-OY	R2203	1-249-411-11	CARBON	330 5% 1/4W
Q2206	8-729-021-73	TRANSISTOR	2SC2229-OY	R2204	1-249-418-11	CARBON	1.2K 5% 1/4W
Q2301	8-729-045-15	TRANSISTOR	2SC5169-FG	R2205	1-249-425-11	CARBON	4.7K 5% 1/4W
Q2303	8-729-119-78	TRANSISTOR	2SC2785-HFE	R2206	1-249-418-11	CARBON	1.2K 5% 1/4W
Q2304	8-729-199-22	TRANSISTOR	2SA992-FA	R2207	1-249-414-11	CARBON	560 5% 1/4W
Q2305	8-729-021-74	TRANSISTOR	2SA949-OY	R2208	1-247-843-11	CARBON	3.3K 5% 1/4W
Q2306	8-729-021-73	TRANSISTOR	2SC2229-OY	R2209	1-249-560-31	CARBON	2.2K 5% 1/4W
Q2401	8-729-045-15	TRANSISTOR	2SC5169-FG	R2210	1-249-594-31	CARBON	56K 5% 1/4W
Q2403	8-729-119-78	TRANSISTOR	2SC2785-HFE	R2211	1-249-441-11	CARBON	100K 5% 1/4W
Q2404	8-729-199-22	TRANSISTOR	2SA992-FA	R2212	1-249-441-11	CARBON	100K 5% 1/4W
Q2405	8-729-021-74	TRANSISTOR	2SA949-OY	△R2213	1-249-413-11	CARBON	470 5% 1/4W F
Q2406	8-729-021-73	TRANSISTOR	2SC2229-OY	△R2214	1-249-406-11	CARBON	120 5% 1/4W F
Q2501	8-729-045-15	TRANSISTOR	2SC5169-FG	△R2215	1-249-406-11	CARBON	120 5% 1/4W F
Q2503	8-729-119-78	TRANSISTOR	2SC2785-HFE	R2216	1-249-435-11	CARBON	33K 5% 1/4W
Q2504	8-729-199-22	TRANSISTOR	2SA992-FA	R2219	1-249-407-11	CARBON	150 5% 1/4W
Q2505	8-729-021-74	TRANSISTOR	2SA949-OY	R2301	1-249-417-11	CARBON	1K 5% 1/4W
Q2506	8-729-021-73	TRANSISTOR	2SC2229-OY	R2302	1-249-438-11	CARBON	56K 5% 1/4W
Q2601	8-729-021-82	TRANSISTOR	2SD2396K	R2303	1-249-411-11	CARBON	330 5% 1/4W
Q2602	8-729-024-93	TRANSISTOR	2SB1565E	R2304	1-249-418-11	CARBON	1.2K 5% 1/4W
Q2603	8-729-140-84	TRANSISTOR	2SC1841-PAFAEA	R2305	1-249-425-11	CARBON	4.7K 5% 1/4W
< RESISTOR >				R2306	1-249-418-11	CARBON	1.2K 5% 1/4W
R2001	1-249-417-11	CARBON	1K 5% 1/4W	R2307	1-249-414-11	CARBON	560 5% 1/4W
R2002	1-249-438-11	CARBON	56K 5% 1/4W	R2308	1-247-843-11	CARBON	3.3K 5% 1/4W
R2003	1-249-411-11	CARBON	330 5% 1/4W	R2309	1-249-560-31	CARBON	2.2K 5% 1/4W
R2004	1-249-418-11	CARBON	1.2K 5% 1/4W	R2310	1-249-594-31	CARBON	56K 5% 1/4W
R2005	1-249-425-11	CARBON	4.7K 5% 1/4W	R2311	1-249-441-11	CARBON	100K 5% 1/4W
R2006	1-249-418-11	CARBON	1.2K 5% 1/4W	R2312	1-249-441-11	CARBON	100K 5% 1/4W
R2007	1-249-414-11	CARBON	560 5% 1/4W	△R2313	1-249-413-11	CARBON	470 5% 1/4W F
R2008	1-247-843-11	CARBON	3.3K 5% 1/4W	△R2314	1-249-406-11	CARBON	120 5% 1/4W F
R2009	1-249-560-31	CARBON	2.2K 5% 1/4W	△R2315	1-249-406-11	CARBON	120 5% 1/4W F
R2010	1-249-594-31	CARBON	56K 5% 1/4W	R2316	1-249-435-11	CARBON	33K 5% 1/4W
R2011	1-249-441-11	CARBON	100K 5% 1/4W	R2319	1-249-407-11	CARBON	150 5% 1/4W
R2012	1-249-441-11	CARBON	100K 5% 1/4W	R2401	1-249-417-11	CARBON	1K 5% 1/4W
△R2013	1-249-413-11	CARBON	470 5% 1/4W F	R2402	1-249-438-11	CARBON	56K 5% 1/4W
△R2014	1-249-406-11	CARBON	120 5% 1/4W F	R2403	1-249-411-11	CARBON	330 5% 1/4W
△R2015	1-249-406-11	CARBON	120 5% 1/4W F	R2404	1-249-418-11	CARBON	1.2K 5% 1/4W
R2016	1-249-435-11	CARBON	33K 5% 1/4W	R2405	1-249-425-11	CARBON	4.7K 5% 1/4W
R2019	1-249-407-11	CARBON	150 5% 1/4W	R2406	1-249-418-11	CARBON	1.2K 5% 1/4W
R2101	1-249-417-11	CARBON	1K 5% 1/4W	R2407	1-249-414-11	CARBON	560 5% 1/4W
R2102	1-249-438-11	CARBON	56K 5% 1/4W	R2408	1-247-843-11	CARBON	3.3K 5% 1/4W
R2103	1-249-411-11	CARBON	330 5% 1/4W	R2409	1-249-560-31	CARBON	2.2K 5% 1/4W
R2104	1-249-418-11	CARBON	1.2K 5% 1/4W	R2410	1-249-594-31	CARBON	56K 5% 1/4W
R2105	1-249-425-11	CARBON	4.7K 5% 1/4W	R2411	1-249-441-11	CARBON	100K 5% 1/4W
R2106	1-249-418-11	CARBON	1.2K 5% 1/4W	R2412	1-249-441-11	CARBON	100K 5% 1/4W
R2107	1-249-414-11	CARBON	560 5% 1/4W	△R2413	1-249-413-11	CARBON	470 5% 1/4W F

The components identified by mark △ or dotted line with mark △ are critical for safety. Replace only with part number specified.

Les composants identifiés par une marque △ sont critiques pour la sécurité. Ne les remplacer que par une pièce portant le numéro spécifié.

以阴影和 △标志来识别的零部件，在安全方面具有关键性。因此只能以规定号码的零部件来更换。

STR-DA1000ES/DB790

Ver 1.1

A-CLASS

AC

AU-IN

Ref. No.	Part No.	Description	Remark
△ R2414	1-249-406-11	CARBON 120 5%	1/4W F
△ R2415	1-249-406-11	CARBON 120 5%	1/4W F
R2416	1-249-435-11	CARBON 33K 5%	1/4W
R2419	1-249-407-11	CARBON 150 5%	1/4W
R2501	1-249-417-11	CARBON 1K 5%	1/4W
R2502	1-249-438-11	CARBON 56K 5%	1/4W
R2503	1-249-411-11	CARBON 330 5%	1/4W
R2504	1-249-418-11	CARBON 1.2K 5%	1/4W
R2505	1-249-425-11	CARBON 4.7K 5%	1/4W
R2506	1-249-418-11	CARBON 1.2K 5%	1/4W
R2507	1-249-414-11	CARBON 560 5%	1/4W
R2508	1-247-843-11	CARBON 3.3K 5%	1/4W
R2509	1-249-560-31	CARBON 2.2K 5%	1/4W
R2510	1-249-594-31	CARBON 56K 5%	1/4W
R2511	1-249-441-11	CARBON 100K 5%	1/4W
R2512	1-249-441-11	CARBON 100K 5%	1/4W
△ R2513	1-249-413-11	CARBON 470 5%	1/4W F
△ R2514	1-249-406-11	CARBON 120 5%	1/4W F
△ R2515	1-249-406-11	CARBON 120 5%	1/4W F
R2516	1-249-435-11	CARBON 33K 5%	1/4W
R2519	1-249-407-11	CARBON 150 5%	1/4W
△ R2601	1-215-873-81	METAL OXIDE 4.7K 5%	1W F
△ R2602	1-260-107-11	CARBON 4.7K 5%	1/2W F
△ R2603	1-249-381-11	CARBON 1 5%	1/4W F
△ R2604	1-249-381-11	CARBON 1 5%	1/4W F
R2605	1-249-413-11	CARBON 470 5%	1/4W
R2606	1-249-413-11	CARBON 470 5%	1/4W
R2607	1-247-883-00	CARBON 150K 5%	1/4W
R2610	1-249-429-11	CARBON 10K 5%	1/4W

1-688-632-11 AC BOARD

< CAPACITOR >

△ C3	1-117-703-11	CERAMIC 0.0047uF 99%	250V (DB790)
C52	1-136-287-11	FILM 0.0047uF 5%	100V
C53	1-137-465-11	MYLAR 0.056uF 5%	100V
C54	1-126-768-11	ELECT 2200uF 20%	16V
C55	1-126-960-11	ELECT 1uF 20%	50V
C56	1-128-817-11	CERAMIC 470PF 5%	50V

< CONNECTOR >

* CN1	1-565-792-11	PIN, CONNECTOR (3.96mm PITCH) 2P	
CN2	1-564-321-00	PIN, CONNECTOR (3.96mm PITCH) 2P	
CN51	1-778-227-41	CONNECTOR, BOARD TO BOARD 6P	

< JACK >

△ CNJ1	1-785-285-11	OUTLET, AC (1P) (AC OUTLET)	(DB790: SP, MY)
--------	--------------	-----------------------------	-----------------

△ CNJ1	1-785-834-11	OUTLET (1P) (AC OUTLET)	(DA1000ES/DB790: TW)
--------	--------------	-------------------------	----------------------

< DIODE >

D51	8-719-991-33	DIODE 1SS133T-77	
D52	8-719-991-33	DIODE 1SS133T-77	
D53	8-719-991-33	DIODE 1SS133T-77	
D54	8-719-210-21	DIODE 11EQS04	

Ref. No.	Part No.	Description	Remark
D55	8-719-210-21	DIODE 11EQS04	
D56	8-719-210-21	DIODE 11EQS04	
D57	8-719-210-21	DIODE 11EQS04	
< TRANSISTOR >			
Q51	8-729-119-78	TRANSISTOR 2SC2785-HFE	
Q52	8-729-201-53	TRANSISTOR 2SA1015-GR	
Q53	8-729-116-02	TRANSISTOR BA1A4M-TP	
Q54	8-729-119-79	TRANSISTOR 2SC2785-FEK	
Q55	8-729-116-02	TRANSISTOR BA1A4M-TP	
< RESISTOR >			
△ R1	1-219-237-11	SOLID 3.3M 20%	1/2W (DA1000ES)
R51	1-249-421-11	CARBON 2.2K 5%	1/4W
R52	1-249-429-11	CARBON 10K 5%	1/4W
R53	1-249-415-11	CARBON 680 5%	1/4W
R54	1-249-437-11	CARBON 47K 5%	1/4W
R55	1-249-435-11	CARBON 33K 5%	1/4W
R56	1-249-429-11	CARBON 10K 5%	1/4W
R57	1-249-429-11	CARBON 10K 5%	1/4W
R59	1-249-441-11	CARBON 100K 5%	1/4W
R60	1-249-429-11	CARBON 10K 5%	1/4W
R61	1-249-435-11	CARBON 33K 5%	1/4W
< RELAY >			
△ RY1	1-755-298-11	RELAY	
< TRANSFORMER >			
△ T2	1-435-281-11	TRANSFORMER, POWER (DA1000ES)	
△ T2	1-435-282-11	TRANSFORMER, POWER (DB790: AEP, UK, SP, MY, KR, AUS, CH)	
△ T2	1-435-563-11	TRANSFORMER, POWER (DB790: TW)	

A-4733-528-A	AU-IN BOARD, COMPLETE (DA1000ES)		
A-4733-548-A	AU-IN BOARD, COMPLETE (DB790: SP, MY, TW, KR, CH)		
A-4733-570-A	AU-IN BOARD, COMPLETE (DB790: AEP, UK, AUS)		

< CAPACITOR >			
C107	1-128-825-11	CERAMIC 2200PF 5%	50V
C110	1-126-933-11	ELECT 100uF 20%	16V (DA1000ES)
C110	1-127-718-11	ELECT 100uF 20%	16V (DB790: SP, MY, TW, KR, CH)
C110	1-135-681-11	ELECT 100uF 25V	(DB790: AEP, UK, AUS)
C111	1-126-933-11	ELECT 100uF 20%	16V (DA1000ES)
C111	1-127-718-11	ELECT 100uF 20%	16V (DB790: SP, MY, TW, KR, CH)
C111	1-135-681-11	ELECT 100uF 25V	(DB790: AEP, UK, AUS)
C112	1-126-933-11	ELECT 100uF 20%	16V (DA1000ES)
C112	1-127-718-11	ELECT 100uF 20%	16V (DB790: SP, MY, TW, KR, CH)

The components identified by mark △ or dotted line with mark △ are critical for safety. Replace only with part number specified.

Les composants identifiés par une marque △ sont critiques pour la sécurité. Ne les remplacer que par une pièce portant le numéro spécifié.

以阴影和 △ 标志来识别的零部件，在安全方面具有关键性。因此只能以规定号码的零部件来更换。

Ref. No.	Part No.	Description	Remark	Ref. No.	Part No.	Description	Remark
C112	1-135-681-11	ELECT	100uF 25V (DB790: AEP, UK, AUS)	C171	1-126-933-11	ELECT	100uF 20% 16V (DA1000ES)
C113	1-126-933-11	ELECT	100uF 20% 16V (DA1000ES)	C171	1-127-718-11	ELECT	100uF 20% 16V (DB790: SP, MY, TW, KR, CH)
C113	1-127-718-11	ELECT	100uF 20% 16V (DB790: SP, MY, TW, KR, CH)	C171	1-135-681-11	ELECT	100uF 25V (DB790: AEP, UK, AUS)
C113	1-135-681-11	ELECT	100uF 25V (DB790: AEP, UK, AUS)	C174	1-127-876-11	CERAMIC	0.01uF 10% 50V
C114	1-126-933-11	ELECT	100uF 20% 16V (DA1000ES)	C175	1-128-809-11	CERAMIC	100PF 5% 50V
C114	1-127-718-11	ELECT	100uF 20% 16V (DB790: SP, MY, TW, KR, CH)	C181	1-126-933-11	ELECT	100uF 20% 16V (DA1000ES)
C114	1-135-681-11	ELECT	100uF 25V (DB790: AEP, UK, AUS)	C181	1-127-718-11	ELECT	100uF 20% 16V (DB790: SP, MY, TW, KR, CH)
C115	1-126-933-11	ELECT	100uF 20% 16V (DA1000ES)	C181	1-135-681-11	ELECT	100uF 25V (DB790: AEP, UK, AUS)
C115	1-127-718-11	ELECT	100uF 20% 16V (DB790: SP, MY, TW, KR, CH)	< CONNECTOR >			
C115	1-135-681-11	ELECT	100uF 25V (DB790: AEP, UK, AUS)	CN102	1-764-867-41	CONNECTOR, BOARD TO BOARD 20P	
C120	1-127-876-11	CERAMIC	0.01uF 10% 50V	CN103	1-764-867-41	CONNECTOR, BOARD TO BOARD 20P	
C121	1-127-880-11	CERAMIC	0.022uF 10% 50V	CN104	1-770-011-41	CONNECTOR, BOARD TO BOARD 4P	
C122	1-127-880-11	CERAMIC	0.022uF 10% 50V	< IC >			
C123	1-128-809-11	CERAMIC	100PF 5% 50V	IC101	6-703-975-01	IC TC9274N-017	
C131	1-128-809-11	CERAMIC	100PF 5% 50V (DB790)	IC110	8-759-167-88	IC NJM4565D	
C132	1-128-809-11	CERAMIC	100PF 5% 50V (DB790)	IC111	8-759-167-88	IC NJM4565D	
C133	1-128-813-11	CERAMIC	220PF 5% 50V (DB790)	IC112	8-759-167-88	IC NJM4565D	
C134	1-128-813-11	CERAMIC	220PF 5% 50V (DB790)	IC131	8-759-636-74	IC M5218AP-22	
C135	1-119-821-11	ELECT	2.2uF 20% 50V (DB790)	IC171	8-759-167-88	IC NJM4565D	
C135	1-126-961-11	ELECT	2.2uF 20% 50V (DA1000ES)	IC172	8-759-167-88	IC NJM4565D	
C136	1-119-821-11	ELECT	2.2uF 20% 50V (DB790)	IC173	8-759-590-10	IC TC9273F-012 (EL)	
C136	1-126-961-11	ELECT	2.2uF 20% 50V (DA1000ES)	< JACK >			
C137	1-128-809-11	CERAMIC	100PF 5% 50V	J101	1-793-345-11	JACK, PIN 6P (ANALOG MULTI CH IN FRONT, SURR, CENTER, SUB WOOFER)	
C138	1-128-809-11	CERAMIC	100PF 5% 50V	J131	1-695-188-31	JACK, PIN 4P (ANALOG MD/TAPE OUT, CD/SACD IN)	
C139	1-126-934-11	ELECT	220uF 20% 16V (DA1000ES)	J151	1-695-188-31	JACK, PIN 4P (ANALOG PHONO IN, MD/TAPE IN)	
C139	1-128-832-11	ELECT	220uF 20% 10V (DB790)	< RESISTOR >			
C140	1-126-934-11	ELECT	220uF 20% 16V (DA1000ES)	R101	1-249-417-11	CARBON	1K 5% 1/4W
C140	1-128-832-11	ELECT	220uF 20% 10V (DB790)	R102	1-249-417-11	CARBON	1K 5% 1/4W
C141	1-125-896-11	MYLAR	0.0091uF 5% 50V	R103	1-249-417-11	CARBON	1K 5% 1/4W
C142	1-125-896-11	MYLAR	0.0091uF 5% 50V	R104	1-249-417-11	CARBON	1K 5% 1/4W
C143	1-136-159-00	MYLAR	0.033uF 5% 50V	R105	1-249-417-11	CARBON	1K 5% 1/4W
C144	1-136-159-00	MYLAR	0.033uF 5% 50V	R106	1-249-417-11	CARBON	1K 5% 1/4W
C145	1-119-821-11	ELECT	2.2uF 20% 50V (DB790)	R110	1-249-437-11	CARBON	47K 5% 1/4W
C145	1-126-961-11	ELECT	2.2uF 20% 50V (DA1000ES)	R111	1-249-437-11	CARBON	47K 5% 1/4W
C146	1-119-821-11	ELECT	2.2uF 20% 50V (DB790)	R112	1-249-437-11	CARBON	47K 5% 1/4W
C146	1-126-961-11	ELECT	2.2uF 20% 50V (DA1000ES)	R113	1-249-437-11	CARBON	47K 5% 1/4W
				R114	1-249-437-11	CARBON	47K 5% 1/4W
				R115	1-249-437-11	CARBON	47K 5% 1/4W
				R119	1-249-417-11	CARBON	1K 5% 1/4W
				R131	1-249-421-11	CARBON	2.2K 5% 1/4W (DB790)
				R132	1-249-421-11	CARBON	2.2K 5% 1/4W (DB790)
				R133	1-249-441-11	CARBON	100K 5% 1/4W
				R134	1-249-441-11	CARBON	100K 5% 1/4W
				R135	1-249-408-11	CARBON	180 5% 1/4W

AU-IN **COMP-V**

Ref. No.	Part No.	Description	Remark
R136	1-249-408-11	CARBON	180 5% 1/4W
R137	1-249-428-11	CARBON	8.2K 5% 1/4W
R138	1-249-428-11	CARBON	8.2K 5% 1/4W
R139	1-249-441-11	CARBON	100K 5% 1/4W
R140	1-249-441-11	CARBON	100K 5% 1/4W
R141	1-247-807-31	CARBON	100 5% 1/4W
R142	1-247-807-31	CARBON	100 5% 1/4W
R143	1-249-441-11	CARBON	100K 5% 1/4W
R144	1-249-441-11	CARBON	100K 5% 1/4W
R145	1-249-413-11	CARBON	470 5% 1/4W
R146	1-249-413-11	CARBON	470 5% 1/4W
R147	1-249-441-11	CARBON	100K 5% 1/4W
R148	1-249-441-11	CARBON	100K 5% 1/4W
R151	1-249-417-11	CARBON	1K 5% 1/4W
R152	1-249-417-11	CARBON	1K 5% 1/4W
R153	1-249-421-11	CARBON	2.2K 5% 1/4W
R154	1-249-421-11	CARBON	2.2K 5% 1/4W
R155	1-249-417-11	CARBON	1K 5% 1/4W
R156	1-249-417-11	CARBON	1K 5% 1/4W
R171	1-249-429-11	CARBON	10K 5% 1/4W
R172	1-249-431-11	CARBON	15K 5% 1/4W
R173	1-249-425-11	CARBON	4.7K 5% 1/4W
R174	1-249-431-11	CARBON	15K 5% 1/4W
R175	1-249-429-11	CARBON	10K 5% 1/4W
R176	1-249-429-11	CARBON	10K 5% 1/4W
R177	1-249-429-11	CARBON	10K 5% 1/4W
R178	1-249-417-11	CARBON	1K 5% 1/4W
R181	1-249-429-11	CARBON	10K 5% 1/4W
R182	1-249-431-11	CARBON	15K 5% 1/4W
R183	1-249-425-11	CARBON	4.7K 5% 1/4W
R184	1-249-431-11	CARBON	15K 5% 1/4W
R185	1-249-429-11	CARBON	10K 5% 1/4W
R186	1-249-429-11	CARBON	10K 5% 1/4W
R187	1-249-429-11	CARBON	10K 5% 1/4W
△R840	1-249-399-11	CARBON	33 5% 1/4W F
△R845	1-249-399-11	CARBON	33 5% 1/4W F

A-4733-521-A COMP-V BOARD, COMPLETE (DA1000ES)
A-4733-546-A COMP-V BOARD, COMPLETE (DB790)

< CAPACITOR >

C351	1-127-868-11	CERAMIC	2200PF 10% 50V
C360	1-128-818-11	CERAMIC	560PF 5% 50V (DA1000ES)
C361	1-128-816-11	CERAMIC	390PF 5% 50V (DA1000ES)
C362	1-126-947-11	ELECT	47uF 20% 35V (DA1000ES)
C363	1-128-801-11	CERAMIC	22PF 5% 50V (DA1000ES)
C364	1-162-201-31	CERAMIC	12PF 5% 50V (DA1000ES)
C365	1-126-947-11	ELECT	47uF 20% 35V (DA1000ES)
C366	1-127-888-11	CERAMIC	0.1uF 10% 50V (DA1000ES)
C367	1-127-876-11	CERAMIC	0.01uF 10% 50V (DA1000ES)

Ref. No.	Part No.	Description	Remark
C368	1-126-963-11	ELECT	4.7uF 20% 50V (DA1000ES)
C369	1-130-495-00	MYLAR	0.1uF 5% 50V (DA1000ES)
C370	1-162-201-31	CERAMIC	12PF 5% 50V (DA1000ES)
C371	1-128-801-11	CERAMIC	22PF 5% 50V (DA1000ES)
C372	1-162-201-31	CERAMIC	12PF 5% 50V (DA1000ES)
C373	1-128-801-11	CERAMIC	22PF 5% 50V (DA1000ES)
C374	1-126-935-11	ELECT	470uF 20% 16V (DA1000ES)
C375	1-126-965-11	ELECT	22uF 20% 50V (DA1000ES)
C376	1-126-947-11	ELECT	47uF 20% 35V (DA1000ES)
C377	1-127-888-11	CERAMIC	0.1uF 10% 50V (DA1000ES)
C378	1-127-888-11	CERAMIC	0.1uF 10% 50V (DA1000ES)
C379	1-128-812-11	CERAMIC	180PF 5% 50V (DA1000ES)
C380	1-127-876-11	CERAMIC	0.01uF 10% 50V (DA1000ES)
C381	1-127-876-11	CERAMIC	0.01uF 10% 50V (DA1000ES)
C382	1-127-888-11	CERAMIC	0.1uF 10% 50V (DA1000ES)
C383	1-104-665-11	ELECT	100uF 20% 25V (DA1000ES)
C384	1-127-888-11	CERAMIC	0.1uF 10% 50V (DA1000ES)
C385	1-127-876-11	CERAMIC	0.01uF 10% 50V (DA1000ES)
C386	1-127-876-11	CERAMIC	0.01uF 10% 50V (DA1000ES)
C387	1-126-959-11	ELECT	0.47uF 20% 50V (DA1000ES)
C388	1-127-876-11	CERAMIC	0.01uF 10% 50V (DA1000ES)
C389	1-127-888-11	CERAMIC	0.1uF 10% 50V (DA1000ES)
C390	1-104-665-11	ELECT	100uF 20% 25V (DA1000ES)
C391	1-126-947-11	ELECT	47uF 20% 35V (DA1000ES)
C392	1-127-888-11	CERAMIC	0.1uF 10% 50V (DA1000ES)
C393	1-162-203-31	CERAMIC	15PF 5% 50V (DA1000ES)
C394	1-126-961-11	ELECT	2.2uF 20% 50V (DA1000ES)
C395	1-127-876-11	CERAMIC	0.01uF 10% 50V (DA1000ES)
C396	1-126-963-11	ELECT	4.7uF 20% 50V (DA1000ES)
C397	1-127-876-11	CERAMIC	0.01uF 10% 50V (DA1000ES)
C398	1-128-806-11	CERAMIC	56PF 5% 50V (DA1000ES)

The components identified by mark △ or dotted line with mark △ are critical for safety. Replace only with part number specified.	Les composants identifiés par une marque △ sont critiques pour la sécurité. Ne les remplacer que par une pièce portant le numéro spécifié.	以阴影和 △标志来识别的零部件，在安全方面具有关键性。因此只能以规定号码的零部件来更换。
--	--	--

COMP-V

DC1

Ref. No.	Part No.	Description	Remark	Ref. No.	Part No.	Description	Remark
C399	1-126-959-11	ELECT	0.47uF 20% 50V (DA1000ES)	R376	1-249-414-11	CARBON	560 5% 1/4W (DA1000ES)
		< CONNECTOR >		R377	1-249-416-11	CARBON	820 5% 1/4W (DA1000ES)
CN351	1-573-843-11	CONNECTOR, BOARD TO BOARD 11P		R378	1-249-416-11	CARBON	820 5% 1/4W (DA1000ES)
		< DIODE >		R379	1-249-416-11	CARBON	820 5% 1/4W (DA1000ES)
D351	8-719-991-33	DIODE 1SS133T-77		R380	1-249-430-11	CARBON	12K 5% 1/4W (DA1000ES)
D352	8-719-991-33	DIODE 1SS133T-77		R381	1-249-430-11	CARBON	12K 5% 1/4W (DA1000ES)
		< FERRITE BEAD >		R382	1-249-418-11	CARBON	1.2K 5% 1/4W (DA1000ES)
FB353	1-412-911-11	FERRITE	0uH (DA1000ES)	R383	1-249-411-11	CARBON	330 5% 1/4W (DA1000ES)
FB354	1-412-911-11	FERRITE	0uH (DA1000ES)	R384	1-247-804-11	CARBON	75 5% 1/4W (DA1000ES)
		< IC >		R385	1-247-804-11	CARBON	75 5% 1/4W (DA1000ES)
IC370	8-759-678-99	IC TC90A45F (DA1000ES)		R386	1-249-429-11	CARBON	10K 5% 1/4W (DA1000ES)
IC371	8-759-826-19	IC MM1093NF (DA1000ES)		R387	1-249-429-11	CARBON	10K 5% 1/4W (DA1000ES)
IC372	6-803-031-01	IC NJM2268D (DA1000ES)		R388	1-249-412-11	CARBON	390 5% 1/4W (DA1000ES)
		< JACK >		R389	1-249-412-11	CARBON	390 5% 1/4W (DA1000ES)
J351	1-817-726-11	JACK, PIN 9P (COMPOSITE VIDEO MONITOR OUT, DVD IN, TV/SAT IN)		R390	1-247-903-00	CARBON	1M 5% 1/4W (DA1000ES)
		< COIL >		R391	1-249-431-11	CARBON	15K 5% 1/4W (DA1000ES)
L370	1-410-514-11	INDUCTOR	27uH (DA1000ES)	R392	1-249-426-11	CARBON	5.6K 5% 1/4W (DA1000ES)
L371	1-410-514-11	INDUCTOR	27uH (DA1000ES)			< RELAY >	
L372	1-414-189-31	INDUCTOR	100uH (DA1000ES)	RY351	1-755-184-11	RELAY	
L373	1-414-189-31	INDUCTOR	100uH (DA1000ES)	RY352	1-755-184-11	RELAY	
L374	1-410-514-11	INDUCTOR	27uH (DA1000ES)	RY353	1-755-184-11	RELAY	
L375	1-410-515-11	INDUCTOR	33uH (DA1000ES)	RY354	1-755-184-11	RELAY	
		< TRANSISTOR >				< VIBRATOR >	
Q351	8-729-119-79	TRANSISTOR	2SC2785-FEK	X370	1-781-342-21	OSCILLATOR, CRYSTAL (3.5795MHz)	(DA1000ES)
Q352	8-729-119-79	TRANSISTOR	2SC2785-FEK			*****	
Q370	8-729-119-79	TRANSISTOR	2SC2785-FEK (DA1000ES)				
Q371	8-729-119-79	TRANSISTOR	2SC2785-FEK (DA1000ES)				
Q372	8-729-119-79	TRANSISTOR	2SC2785-FEK (DA1000ES)				
		< RESISTOR >					
R357	1-249-421-11	CARBON	2.2K 5% 1/4W				
R358	1-249-429-11	CARBON	10K 5% 1/4W				
R359	1-249-421-11	CARBON	2.2K 5% 1/4W				
R360	1-249-429-11	CARBON	10K 5% 1/4W				
R361	1-249-417-11	CARBON	1K 5% 1/4W (DA1000ES)				
		< CAPACITOR >					
R362	1-249-417-11	CARBON	1K 5% 1/4W (DA1000ES)	C902	1-126-953-11	ELECT	2200uF 20% 35V (DA1000ES)
R371	1-249-418-11	CARBON	1.2K 5% 1/4W (DA1000ES)	C902	1-127-732-51	ELECT	2200uF 20% 35V (DB790: SP, MY, TW, KR)
R372	1-249-411-11	CARBON	330 5% 1/4W (DA1000ES)	C902	1-135-781-51	ELECT	2200uF 35V (DB790: AEP, UK, AUS, CH)
R373	1-249-416-11	CARBON	820 5% 1/4W (DA1000ES)	C903	1-126-952-11	ELECT	1000uF 20% 35V (DA1000ES)
R374	1-247-903-00	CARBON	1M 5% 1/4W (DA1000ES)	C903	1-127-731-51	ELECT	1000uF 20% 35V (DB790: SP, MY, TW, KR)
R375	1-249-418-11	CARBON	1.2K 5% 1/4W (DA1000ES)	C903	1-135-780-51	ELECT	1000uF 35V (DB790: AEP, UK, AUS, CH)
		< RELAY >					
		< VIBRATOR >					
		< CAPACITOR >					

STR-DA1000ES/DB790

Ver 1.3

DC1

DC2

Ref. No.	Part No.	Description	Remark
C904	1-126-967-11	ELECT	47uF 20% 50V
C906	1-126-967-11	ELECT	47uF 20% 50V
C907	1-126-937-11	ELECT	4700uF 20% 16V
			(DA1000ES)
C907	1-127-723-51	ELECT	4700uF 20% 16V (DB790: SP, MY, TW, KR)
C907	1-135-696-51	ELECT	4700uF 16V (DB790: AEP, UK, AUS, CH)
C908	1-126-767-11	ELECT	1000uF 20% 16V
C909	1-126-970-11	ELECT	330uF 20% 50V
C915	1-100-376-13	ELECT	12000uF 10% 63V (DB790)
C915	1-109-932-13	ELECT (BLOCK)	10000uF 20% 71V (DA1000ES)
C916	1-100-376-13	ELECT	12000uF 10% 63V (DB790)
C916	1-109-932-13	ELECT (BLOCK)	10000uF 20% 71V (DA1000ES)
C917	1-136-196-11	FILM	0.033uF 5% 250V (DA1000ES)
C917	1-137-350-11	MYLAR	0.015uF 5% 400V (DB790)
C918	1-136-196-11	FILM	0.033uF 5% 250V (DA1000ES)
C918	1-137-350-11	MYLAR	0.015uF 5% 400V (DB790)
C919	1-104-999-11	MYLAR	0.1uF 5% 200V (DB790)
C920	1-162-306-11	CERAMIC	0.01uF 30% 16V
C923	1-104-666-11	ELECT	220uF 20% 25V
C924	1-104-666-11	ELECT	220uF 20% 25V
C925	1-104-666-11	ELECT	220uF 20% 25V
C926	1-104-666-11	ELECT	220uF 20% 25V
		< CONNECTOR >	
CN906	1-691-768-11	PLUG (MICRO CONNECTOR)	6P
CN907	1-691-770-11	PLUG (MICRO CONNECTOR)	8P
CN909	1-784-922-11	PIN, CONNECTOR	5P
CN910	1-785-101-11	PIN, CONNECTOR (3.96mm PITCH)	3P
CN911	1-785-101-11	PIN, CONNECTOR (3.96mm PITCH)	3P
CN912	1-778-226-21	CONNECTOR, BOARD TO BOARD	6P
CN913	1-564-320-00	PIN, CONNECTOR (3.96mm PITCH)	2P
		< DIODE >	
D902	8-719-983-86	DIODE	MTZJ-T-72-33A
D903	8-719-024-99	DIODE	11ES2-NTA2B
D904	8-719-024-99	DIODE	11ES2-NTA2B
D905	8-719-024-99	DIODE	11ES2-NTA2B
D906	8-719-024-99	DIODE	11ES2-NTA2B
D908	8-719-510-53	DIODE	D4SB60L
D909	8-719-024-99	DIODE	11ES2-NTA2B
D912	8-719-024-99	DIODE	11ES2-NTA2B
D913	8-719-024-99	DIODE	11ES2-NTA2B
D914	8-719-505-60	DIODE	S5VB60
D915	8-719-024-99	DIODE	11ES2-NTA2B
D916	8-719-024-99	DIODE	11ES2-NTA2B

Ref. No.	Part No.	Description	Remark
		< GROUND TERMINAL >	
* EB901	1-537-738-21	TERMINAL, EARTH	
		< TRANSISTOR >	
Q903	8-729-041-38	TRANSISTOR	2SB1241-Q-TV2
		< RESISTOR >	
R902	1-249-433-11	CARBON	22K 5% 1/4W
R904	1-249-429-11	CARBON	10K 5% 1/4W
△ R910	1-249-385-11	CARBON	2.2 5% 1/4W F
△ R911	1-216-349-81	METAL OXIDE	1 5% 1W F
△ R912	1-216-349-81	METAL OXIDE	1 5% 1W F
△ R913	1-249-407-11	CARBON	150 5% 1/4W F (DB790)

	A-4733-517-A	DC2 BOARD, COMPLETE	(DA1000ES)
	A-4733-543-A	DC2 BOARD, COMPLETE	(DB790: SP, MY, TW, KR, CH)
	A-4733-574-A	DC2 BOARD, COMPLETE	(DB790: AEP, UK, AUS)

		< CAPACITOR >	
C952	1-126-947-11	ELECT	47uF 20% 35V
C953	1-136-169-00	MYLAR	0.22uF 5% 50V
C954	1-127-888-11	CERAMIC	0.1uF 10% 50V
C955	1-136-169-00	MYLAR	0.22uF 5% 50V
C956	1-126-935-11	ELECT	470uF 20% 16V
C957	1-126-918-51	ELECT	4700uF 20% 6.3V (DA1000ES)
C957	1-137-661-51	ELECT	4700uF 20% 6.3V (DB790: AEP, UK, AUS)
C957	1-137-661-91	ELECT	4700uF 20% 6.3V (DB790: SP, MY, TW, KR, CH)
C958	1-136-169-00	MYLAR	0.22uF 5% 50V
C959	1-127-888-11	CERAMIC	0.1uF 10% 50V
C960	1-136-169-00	MYLAR	0.22uF 5% 50V
C961	1-126-942-61	ELECT	1000uF 20% 25V (DA1000ES)
C961	1-127-731-51	ELECT	1000uF 20% 35V (DB790: SP, MY, TW, KR, CH)
C961	1-135-685-51	ELECT	1000uF 25V (DB790: AEP, UK, AUS)
C962	1-136-169-00	MYLAR	0.22uF 5% 50V
C963	1-126-942-61	ELECT	1000uF 20% 25V (DA1000ES)
C963	1-127-731-51	ELECT	1000uF 20% 35V (DB790: SP, MY, TW, KR, CH)
C963	1-135-685-51	ELECT	1000uF 25V (DB790: AEP, UK, AUS)
C964	1-127-888-11	CERAMIC	0.1uF 10% 50V
C965	1-127-888-11	CERAMIC	0.1uF 10% 50V (DB790)
		< CONNECTOR >	
CN951	1-778-227-41	CONNECTOR, BOARD TO BOARD	6P

The components identified by mark △ or dotted line with mark △ are critical for safety. Replace only with part number specified.	Les composants identifiés par une marque △ sont critiques pour la sécurité. Ne les remplacer que par une pièce portant le numéro spécifié.	以阴影和 △ 标志来识别的零部件，在安全方面具有关键性。因此只能以规定号码的零部件来更换。
--	--	---

DC2 DIGITAL

Ref. No.	Part No.	Description	Remark	Ref. No.	Part No.	Description	Remark
		< IC >					
IC951	8-759-245-79	IC TA79005S		C1112	1-162-974-11	CERAMIC CHIP 0.01uF	50V
		< TRANSISTOR >		C1113	1-164-156-11	CERAMIC CHIP 0.1uF	25V
Q953	8-729-140-98	TRANSISTOR 2SD773-34		C1114	1-162-905-11	CERAMIC CHIP 1PF	0.25PF 50V
Q954	8-729-029-23	TRANSISTOR DTA114TSA-TP		C1115	1-162-923-11	CERAMIC CHIP 47PF	5% 50V
Q955	8-729-029-66	TRANSISTOR DTC114ESA		C1116	1-126-916-11	ELECT 1000uF	20% 6.3V (DA1000ES)
Q956	8-729-029-66	TRANSISTOR DTC114ESA					
Q957	8-729-140-93	TRANSISTOR 2SB733-34		C1116	1-135-656-11	ELECT 1000uF	6.3V (DB790: AEP, UK)
Q958	8-729-029-66	TRANSISTOR DTC114ESA		C1116	1-137-658-11	ELECT 1000uF	20% 6.3V (DB790: SP, MY, TW, KR, AUS, CH)
Q959	8-729-140-93	TRANSISTOR 2SB733-34		C1117	1-164-156-11	CERAMIC CHIP 0.1uF	25V
Q960	8-729-024-93	TRANSISTOR 2SB1565E (DB790)		C1118	1-115-416-11	CERAMIC CHIP 0.001uF	5% 25V
Q961	8-729-119-79	TRANSISTOR 2SC2785-FEK (DB790)		C1119	1-126-965-11	ELECT 22uF	20% 50V (DA1000ES)
Q962	8-729-119-79	TRANSISTOR 2SC2785-FEK (DB790)					
		< RESISTOR >		C1119	1-128-858-11	ELECT 22uF	20% 50V (DB790: SP, MY, TW, KR, AUS, CH)
R954	1-249-417-11	CARBON 1K 5%	1/4W	C1119	1-135-744-11	ELECT 22uF	50V (DB790: AEP, UK)
R955	1-249-415-11	CARBON 680 5%	1/4W	C1120	1-164-156-11	CERAMIC CHIP 0.1uF	25V
R956	1-249-429-11	CARBON 10K 5%	1/4W	C1121	1-164-156-11	CERAMIC CHIP 0.1uF	25V
R957	1-249-415-11	CARBON 680 5%	1/4W	C1122	1-164-156-11	CERAMIC CHIP 0.1uF	25V
R958	1-249-429-11	CARBON 10K 5%	1/4W	C1123	1-164-156-11	CERAMIC CHIP 0.1uF	25V
R959	1-249-429-11	CARBON 10K 5%	1/4W	C1124	1-164-156-11	CERAMIC CHIP 0.1uF	25V
R962	1-249-429-11	CARBON 10K 5%	1/4W (DB790)	C1126	1-119-824-11	ELECT 10uF	20% 50V (DB790: SP, MY, TW, KR, AUS, CH)
R963	1-247-847-91	CARBON 4.7K 5%	1/4W (DB790)	C1126	1-126-964-11	ELECT 10uF	20% 50V (DA1000ES)
R964	1-247-887-00	CARBON 220K 5%	1/4W (DB790)	C1126	1-135-743-11	ELECT 10uF	50V (DB790: AEP, UK)
R965	1-249-401-11	CARBON 47 5%	1/4W (DB790)	C1127	1-164-156-11	CERAMIC CHIP 0.1uF	25V

A-4733-508-A	DIGITAL BOARD, COMPLETE (DA1000ES)			C1129	1-115-416-11	CERAMIC CHIP 0.001uF	5% 25V
A-4733-536-A	DIGITAL BOARD, COMPLETE (DB790: SP, MY, TW, KR, AUS, CH)			C1130	1-164-156-11	CERAMIC CHIP 0.1uF	25V
A-4733-576-A	DIGITAL BOARD, COMPLETE (DB790: AEP, UK)			C1131	1-162-927-11	CERAMIC CHIP 100PF	5% 50V

		< CAPACITOR >		C1132	1-162-974-11	CERAMIC CHIP 0.01uF	50V
C1101	1-164-156-11	CERAMIC CHIP 0.1uF	25V	C1133	1-164-156-11	CERAMIC CHIP 0.1uF	25V
C1102	1-126-947-11	ELECT 47uF	20% 35V (DA1000ES)	C1201	1-164-156-11	CERAMIC CHIP 0.1uF	25V
C1102	1-128-840-11	ELECT 47uF	20% 16V (DB790: SP, MY, TW, KR, AUS, CH)	C1202	1-164-156-11	CERAMIC CHIP 0.1uF	25V
C1102	1-135-708-11	ELECT 47uF	16V (DB790: AEP, UK)	C1203	1-164-156-11	CERAMIC CHIP 0.1uF	25V
C1103	1-164-156-11	CERAMIC CHIP 0.1uF	25V	C1204	1-164-156-11	CERAMIC CHIP 0.1uF	25V
C1104	1-162-974-11	CERAMIC CHIP 0.01uF	50V	C1205	1-164-156-11	CERAMIC CHIP 0.1uF	25V
C1105	1-126-947-11	ELECT 47uF	20% 16V (DA1000ES)	C1206	1-164-156-11	CERAMIC CHIP 0.1uF	25V
C1105	1-128-840-11	ELECT 47uF	20% 35V (DB790: SP, MY, TW, KR, AUS, CH)	C1207	1-164-156-11	CERAMIC CHIP 0.1uF	25V
C1105	1-135-708-11	ELECT 47uF	16V (DB790: AEP, UK)	C1208	1-164-156-11	CERAMIC CHIP 0.1uF	25V
C1106	1-164-156-11	CERAMIC CHIP 0.1uF	25V	C1209	1-164-156-11	CERAMIC CHIP 0.1uF	25V
C1107	1-162-974-11	CERAMIC CHIP 0.01uF	50V	C1210	1-164-156-11	CERAMIC CHIP 0.1uF	25V
C1108	1-164-156-11	CERAMIC CHIP 0.1uF	25V	C1211	1-126-935-11	ELECT 470uF	20% 10V (DA1000ES)
C1109	1-162-918-11	CERAMIC CHIP 18PF	5% 50V	C1211	1-128-834-11	ELECT 470uF	20% 16V (DB790: SP, MY, TW, KR, AUS, CH)
C1110	1-162-918-11	CERAMIC CHIP 18PF	5% 50V	C1211	1-135-669-11	ELECT 470uF	10V (DB790: AEP, UK)
C1111	1-164-156-11	CERAMIC CHIP 0.1uF	25V	C1212	1-126-935-11	ELECT 470uF	20% 16V (DA1000ES)
				C1212	1-128-834-11	ELECT 470uF	20% 10V (DB790: SP, MY, TW, KR, AUS, CH)
				C1212	1-135-669-11	ELECT 470uF	10V (DB790: AEP, UK)
				C1213	1-164-156-11	CERAMIC CHIP 0.1uF	25V
				C1214	1-164-156-11	CERAMIC CHIP 0.1uF	25V
				C1216	1-162-927-11	CERAMIC CHIP 100PF	5% 50V

STR-DA1000ES/DB790

Ver 1.1

DIGITAL

Ref. No.	Part No.	Description	Remark	Ref. No.	Part No.	Description	Remark
C1218	1-162-927-11	CERAMIC CHIP	100PF 5%	50V	C1416	1-164-156-11	CERAMIC CHIP 0.1uF 25V
C1219	1-164-156-11	CERAMIC CHIP	0.1uF	25V	C1417	1-126-935-11	ELECT 470uF 20% 16V
C1220	1-162-927-11	CERAMIC CHIP	100PF 5%	50V			(DA1000ES)
C1221	1-164-156-11	CERAMIC CHIP	0.1uF	25V	C1417	1-127-720-11	ELECT 470uF 20% 16V
			(DB790: AEP, UK)	25V			(DB790: SP, MY, TW, KR, AUS, CH)
C1227	1-164-156-11	CERAMIC CHIP	0.1uF	25V	C1417	1-135-711-11	ELECT 470uF 16V
				25V			(DB790: AEP, UK)
C1229	1-164-156-11	CERAMIC CHIP	0.1uF	25V	C1418	1-164-156-11	CERAMIC CHIP 0.1uF 25V
C1230	1-164-156-11	CERAMIC CHIP	0.1uF	25V	C1501	1-126-924-11	ELECT 330uF 20% 10V
C1231	1-164-156-11	CERAMIC CHIP	0.1uF	25V			(DA1000ES)
C1233	1-164-156-11	CERAMIC CHIP	0.1uF	25V	C1501	1-128-833-11	ELECT 330uF 10V
C1234	1-162-920-11	CERAMIC CHIP	27PF 5%	50V			(DB790)
C1235	1-162-920-11	CERAMIC CHIP	27PF 5%	50V	C1502	1-164-156-11	CERAMIC CHIP 0.1uF 25V
C1309	1-164-156-11	CERAMIC CHIP	0.1uF	25V	C1503	1-164-156-11	CERAMIC CHIP 0.1uF 25V
C1310	1-164-156-11	CERAMIC CHIP	0.1uF	25V	C1504	1-126-934-11	ELECT 220uF 20% 16V
C1311	1-164-156-11	CERAMIC CHIP	0.1uF	25V			(DA1000ES)
C1312	1-164-156-11	CERAMIC CHIP	0.1uF	25V	C1504	1-127-719-11	ELECT 220uF 20% 16V
				25V			(DB790: SP, MY, TW, KR, AUS, CH)
C1401	1-164-156-11	CERAMIC CHIP	0.1uF	25V	C1504	1-135-710-11	ELECT 220uF 16V
C1402	1-126-947-11	ELECT	47uF 20%	35V			(DB790: AEP, UK)
				35V	C1505	1-164-156-11	CERAMIC CHIP 0.1uF 25V
C1402	1-128-840-11	ELECT	47uF 20%	16V	C1506	1-164-156-11	CERAMIC CHIP 0.1uF 25V
			(DB790: SP, MY, TW, KR, AUS, CH)	16V			(DA1000ES)
C1402	1-135-708-11	ELECT	47uF	16V	C1507	1-119-824-11	ELECT 10uF 20% 50V
				16V			(DB790: SP, MY, TW, KR, AUS, CH)
C1403	1-119-824-11	ELECT	10uF 20%	50V	C1507	1-126-964-11	ELECT 10uF 20% 50V
			(DB790: SP, MY, TW, KR, AUS, CH)	50V			(DA1000ES)
C1403	1-126-964-11	ELECT	10uF 20%	50V	C1507	1-135-743-11	ELECT 10uF 50V
				50V			(DB790: AEP, UK)
C1403	1-135-743-11	ELECT	10uF	50V	C1508	1-164-156-11	CERAMIC CHIP 0.1uF 25V
				50V			(DB790: AEP, UK)
C1404	1-119-823-11	ELECT	4.7uF 20%	50V	C1509	1-164-156-11	CERAMIC CHIP 0.1uF 25V
			(DB790: SP, MY, TW, KR, AUS, CH)	50V	C1510	1-164-156-11	CERAMIC CHIP 0.1uF 25V
C1404	1-126-963-11	ELECT	4.7uF 20%	50V	C1511	1-164-156-11	CERAMIC CHIP 0.1uF 25V
				50V	C1512	1-164-156-11	CERAMIC CHIP 0.1uF 25V
C1404	1-135-742-11	ELECT	4.7uF	50V	C1513	1-119-824-11	ELECT 10uF 20% 50V
				50V			(DB790: SP, MY, TW, KR, AUS, CH)
C1405	1-164-315-11	CERAMIC CHIP	470PF 5%	50V	C1513	1-126-964-11	ELECT 10uF 20% 50V
C1406	1-119-823-11	ELECT	4.7uF 20%	50V			(DA1000ES)
			(DB790: SP, MY, TW, KR, AUS, CH)	50V	C1513	1-135-743-11	ELECT 10uF 50V
C1406	1-126-963-11	ELECT	4.7uF 20%	50V			(DB790: AEP, UK)
				50V	C1514	1-164-156-11	CERAMIC CHIP 0.1uF 25V
C1406	1-135-742-11	ELECT	4.7uF	50V	C1522	1-162-977-11	CERAMIC CHIP 0.0018uF 10% 50V
				50V	C1523	1-164-218-11	CERAMIC CHIP 180PF 5% 50V
C1407	1-119-824-11	ELECT	10uF 20%	50V			(DA1000ES)
			(DB790: SP, MY, TW, KR, AUS, CH)	50V	C1524	1-126-933-11	ELECT 100uF 20% 16V
C1407	1-126-964-11	ELECT	10uF 20%	50V			(DA1000ES)
				50V	C1524	1-127-718-11	ELECT 100uF 20% 16V
C1407	1-135-743-11	ELECT	10uF	50V			(DB790: SP, MY, TW, KR, AUS, CH)
				50V	C1524	1-135-709-11	ELECT 100uF 16V
C1408	1-164-315-11	CERAMIC CHIP	470PF 5%	50V			(DB790: AEP, UK)
C1409	1-126-947-11	ELECT	47uF 20%	35V	C1532	1-162-977-11	CERAMIC CHIP 0.0018uF 10% 50V
				35V	C1533	1-164-218-11	CERAMIC CHIP 180PF 5% 50V
C1409	1-128-840-11	ELECT	47uF 20%	16V			(DA1000ES)
			(DB790: SP, MY, TW, KR, AUS, CH)	16V	C1534	1-126-933-11	ELECT 100uF 20% 16V
C1409	1-135-708-11	ELECT	47uF	16V			(DA1000ES)
				16V	C1534	1-127-718-11	ELECT 100uF 20% 16V
			(DB790: AEP, UK)	16V			(DB790: SP, MY, TW, KR, AUS, CH)
C1410	1-164-156-11	CERAMIC CHIP	0.1uF	25V	C1534	1-135-709-11	ELECT 100uF 16V
C1411	1-164-156-11	CERAMIC CHIP	0.1uF	25V			(DB790: AEP, UK)
C1412	1-164-156-11	CERAMIC CHIP	0.1uF	25V	C1542	1-162-977-11	CERAMIC CHIP 0.0018uF 10% 50V
C1413	1-164-156-11	CERAMIC CHIP	0.1uF	25V	C1543	1-164-218-11	CERAMIC CHIP 180PF 5% 50V
C1414	1-164-230-11	CERAMIC CHIP	220PF 5%	50V	C1544	1-126-933-11	ELECT 100uF 20% 16V
C1415	1-164-230-11	CERAMIC CHIP	220PF 5%	50V			(DA1000ES)

Ref. No.	Part No.	Description	Remark	Ref. No.	Part No.	Description	Remark
C1544	1-127-718-11	ELECT	100uF 20% 16V (DB790: SP, MY, TW, KR, AUS, CH)	C1618	1-164-156-11	CERAMIC CHIP	0.1uF 25V
C1544	1-135-709-11	ELECT	100uF 16V (DB790: AEP, UK)	C1619	1-164-156-11	CERAMIC CHIP	0.1uF 25V
C1552	1-162-977-11	CERAMIC CHIP	0.0018uF 10% 50V	C1620	1-164-156-11	CERAMIC CHIP	0.1uF 25V
C1553	1-164-218-11	CERAMIC CHIP	180PF 5% 50V	C1624	1-164-156-11	CERAMIC CHIP	0.1uF 25V
C1554	1-126-933-11	ELECT	100uF 20% 16V (DA1000ES)	C1626	1-164-156-11	CERAMIC CHIP	0.1uF 25V
C1554	1-127-718-11	ELECT	100uF 20% 16V (DB790: SP, MY, TW, KR, AUS, CH)	C1627	1-119-824-11	ELECT	10uF 20% 50V
C1554	1-135-709-11	ELECT	100uF 16V (DB790: AEP, UK)	C1628	1-162-908-11	CERAMIC CHIP	3PF 0.25PF 50V
C1562	1-162-977-11	CERAMIC CHIP	0.0018uF 10% 50V	C1629	1-162-908-11	CERAMIC CHIP	3PF 0.25PF 50V
C1563	1-164-218-11	CERAMIC CHIP	180PF 5% 50V	C1631	1-164-156-11	CERAMIC CHIP	0.1uF 25V
C1564	1-126-933-11	ELECT	100uF 20% 16V (DA1000ES)	C1634	1-164-156-11	CERAMIC CHIP	0.1uF 25V
C1564	1-127-718-11	ELECT	100uF 20% 16V (DB790: SP, MY, TW, KR, AUS, CH)	C1635	1-164-156-11	CERAMIC CHIP	0.1uF 25V
C1564	1-135-709-11	ELECT	100uF 16V (DB790: AEP, UK)	C1638	1-162-974-11	CERAMIC CHIP	0.01uF 50V
C1572	1-162-977-11	CERAMIC CHIP	0.0018uF 10% 50V	C1639	1-162-974-11	CERAMIC CHIP	0.01uF 50V
C1573	1-164-218-11	CERAMIC CHIP	180PF 5% 50V	C1640	1-164-230-11	CERAMIC CHIP	220PF 5% 50V
C1574	1-126-933-11	ELECT	100uF 20% 16V (DA1000ES)	C1658	1-162-974-11	CERAMIC CHIP	0.01uF 50V
C1574	1-127-718-11	ELECT	100uF 20% 16V (DB790: SP, MY, TW, KR, AUS, CH)	C1659	1-162-974-11	CERAMIC CHIP	0.01uF 50V
C1574	1-135-709-11	ELECT	100uF 16V (DB790: AEP, UK)	C1905	1-164-156-11	CERAMIC CHIP	0.1uF 25V
C1582	1-162-977-11	CERAMIC CHIP	0.0018uF 10% 50V	C1906	1-126-935-11	ELECT	470uF 20% 16V (DA1000ES)
C1583	1-164-218-11	CERAMIC CHIP	180PF 5% 50V	C1906	1-127-720-11	ELECT	470uF 20% 16V (DB790: SP, MY, TW, KR, AUS, CH)
C1584	1-126-933-11	ELECT	100uF 20% 16V (DA1000ES)	C1906	1-135-711-11	ELECT	470uF 16V (DB790: AEP, UK)
C1584	1-127-718-11	ELECT	100uF 20% 16V (DB790: SP, MY, TW, KR, AUS, CH)	C1908	1-126-935-11	ELECT	470uF 20% 16V (DA1000ES)
C1584	1-135-709-11	ELECT	100uF 16V (DB790: AEP, UK)	C1908	1-127-720-11	ELECT	470uF 20% 16V (DB790: SP, MY, TW, KR, AUS, CH)
C1588	1-162-977-11	CERAMIC CHIP	0.0018uF 10% 50V	C1908	1-135-711-11	ELECT	470uF 16V (DB790: AEP, UK)
C1583	1-164-218-11	CERAMIC CHIP	180PF 5% 50V	C1909	1-164-156-11	CERAMIC CHIP	0.1uF 25V
C1584	1-126-933-11	ELECT	100uF 20% 16V (DA1000ES)	C1910	1-126-934-11	ELECT	220uF 20% 16V (DA1000ES)
C1584	1-127-718-11	ELECT	100uF 20% 16V (DB790: SP, MY, TW, KR, AUS, CH)	C1910	1-128-832-11	ELECT	220uF 20% 10V (DB790)
C1584	1-135-709-11	ELECT	100uF 16V (DB790: AEP, UK)	C1911	1-164-156-11	CERAMIC CHIP	0.1uF 25V
C1592	1-162-977-11	CERAMIC CHIP	0.0018uF 10% 50V (DA1000ES)	C1912	1-126-935-11	ELECT	470uF 20% 16V (DA1000ES)
C1593	1-164-218-11	CERAMIC CHIP	180PF 5% 50V (DA1000ES)	C1912	1-127-720-11	ELECT	470uF 20% 16V (DB790: SP, MY, TW, KR, AUS, CH)
C1594	1-126-933-11	ELECT	100uF 20% 16V (DA1000ES)	C1912	1-135-711-11	ELECT	470uF 16V (DB790: AEP, UK)
C1601	1-164-156-11	CERAMIC CHIP	0.1uF 25V	C1913	1-164-156-11	CERAMIC CHIP	0.1uF 25V
C1602	1-164-156-11	CERAMIC CHIP	0.1uF 25V	C1914	1-126-947-11	ELECT	47uF 20% 35V (DA1000ES)
C1603	1-164-156-11	CERAMIC CHIP	0.1uF 25V	C1914	1-128-840-11	ELECT	47uF 20% 16V (DB790: SP, MY, TW, KR, AUS, CH)
C1604	1-164-156-11	CERAMIC CHIP	0.1uF 25V	C1914	1-135-708-11	ELECT	47uF 16V (DB790: AEP, UK)
C1605	1-164-156-11	CERAMIC CHIP	0.1uF 25V	C1915	1-135-708-11	ELECT	47uF 16V (DB790: AEP, UK)
C1606	1-126-947-11	ELECT	47uF 20% 35V (DA1000ES)	C1916	1-164-156-11	CERAMIC CHIP	0.1uF 25V (DB790: AEP, UK)
C1606	1-128-840-11	ELECT	47uF 20% 16V (DB790: SP, MY, TW, KR, AUS, CH)	< CONNECTOR >			
C1606	1-135-708-11	ELECT	47uF 16V (DB790: AEP, UK)	CN1101	1-764-867-41	CONNECTOR, BOARD TO BOARD	20P
C1608	1-162-974-11	CERAMIC CHIP	0.01uF 50V	CN1102	1-764-867-41	CONNECTOR, BOARD TO BOARD	20P
C1609	1-162-974-11	CERAMIC CHIP	0.01uF 50V	CN1103	1-569-060-11	SOCKET, CONNECTOR	11P (EXCEPT DB790: AEP, UK)
C1610	1-162-974-11	CERAMIC CHIP	0.01uF 50V	CN1103	1-569-321-11	SOCKET, CONNECTOR	15P (DB790: AEP, UK)
C1611	1-162-974-11	CERAMIC CHIP	0.01uF 50V	CN1104	1-784-923-11	PIN, CONNECTOR	7P
C1612	1-164-156-11	CERAMIC CHIP	0.1uF 25V				
C1613	1-162-995-11	CERAMIC CHIP	0.022uF 50V				
C1614	1-162-995-11	CERAMIC CHIP	0.022uF 50V				
C1617	1-162-974-11	CERAMIC CHIP	0.01uF 50V				

STR-DA1000ES/DB790

DIGITAL

Ref. No.	Part No.	Description	Remark	Ref. No.	Part No.	Description	Remark
CN1105	1-784-788-11	CONNECTOR, FFC 27P		IC1901	6-701-887-02	IC SI-3004KWF	
CN1106	1-691-767-11	PLUG (MICRO CONNECTOR) 5P		IC1902	8-759-604-32	IC M5F7810L	
CN1107	1-564-320-00	PIN, CONNECTOR (3.96mm PITCH) 2P		IC1903	8-759-647-10	IC uPC2933HF	
CN1110	1-691-765-11	PLUG (MICRO CONNECTOR) 3P		IC1904	8-759-647-10	IC uPC2933HF	
		< DIODE >		IC1905	8-759-445-59	IC BA033T (DB790: AEP, UK)	
D1001	8-719-016-74	DIODE 1SS352				< JACK >	
D1101	8-719-016-74	DIODE 1SS352		J1101	1-784-431-11	JACK, PIN 1P (DIGITAL COAXIAL IN	
D1601	8-719-016-74	DIODE 1SS352				ASSIGNABLE DVD CD/SACD)	
D1603	8-719-016-74	DIODE 1SS352		J1102	1-563-330-11	JACK (CONTROL A11I)	
D1905	8-719-053-18	DIODE 1SR154-400TE-25				< SHORT >	
D1906	8-719-053-18	DIODE 1SR154-400TE-25		JR1112	1-216-864-11	SHORT CHIP	0 (EXCEPT DB790: AEP, UK)
D1907	8-719-053-18	DIODE 1SR154-400TE-25		JR1113	1-216-864-11	SHORT CHIP	0 (EXCEPT DB790: AEP, UK)
		< FERRITE BEAD >		JR1114	1-216-864-11	SHORT CHIP	0 (EXCEPT DB790: AEP, UK)
FB1101	1-469-152-11	FERRITE	0uH	JR1121	1-216-864-11	SHORT CHIP	0
FB1102	1-469-152-11	FERRITE	0uH	JR1200	1-216-864-11	SHORT CHIP	0
FB1104	1-414-813-11	FERRITE	0uH	JR1201	1-216-864-11	SHORT CHIP	0
FB1105	1-414-813-11	FERRITE	0uH	JR1501	1-216-864-11	SHORT CHIP	0 (DB790)
FB1201	1-469-152-11	FERRITE	0uH	JR1688	1-216-864-11	SHORT CHIP	0
FB1202	1-469-152-11	FERRITE	0uH			< SHORT >	
FB1203	1-414-813-11	FERRITE	0uH	L1901	1-216-864-11	SHORT CHIP	0
FB1401	1-469-152-11	FERRITE	0uH			< TRANSISTOR >	
FB1407	1-414-813-11	FERRITE	0uH	Q1601	8-729-027-43	TRANSISTOR	DTC114EKA-T146
FB1501	1-469-152-11	FERRITE	0uH	Q1602	8-729-230-49	TRANSISTOR	2SC2712-YG
FB1502	1-469-152-11	FERRITE	0uH	Q1603	8-729-230-49	TRANSISTOR	2SC2712-YG
FB1503	1-414-813-11	FERRITE	0uH	Q1607	8-729-230-49	TRANSISTOR	2SC2712-YG
FB1601	1-469-152-11	FERRITE	0uH			< RESISTOR >	
FB1602	1-469-152-11	FERRITE	0uH	R1100	1-216-857-11	METAL CHIP	1M 5% 1/10W
FB1603	1-469-152-11	FERRITE	0uH	R1101	1-216-833-11	METAL CHIP	10K 5% 1/10W
FB1604	1-469-152-11	FERRITE	0uH	R1102	1-216-833-11	METAL CHIP	10K 5% 1/10W
FB1605	1-469-152-11	FERRITE	0uH	R1104	1-216-809-11	METAL CHIP	100 5% 1/10W
		< IC >		R1105	1-216-829-11	METAL CHIP	4.7K 5% 1/10W
IC1101	8-759-825-15	IC LC89056W-E		R1106	1-216-839-11	METAL CHIP	33K 5% 1/10W
IC1102	8-759-242-70	IC TC7WU04F		R1107	1-216-830-11	METAL CHIP	5.6K 5% 1/10W
IC1103	8-759-926-17	IC SN74HC153ANS		R1108	1-216-809-11	METAL CHIP	100 5% 1/10W
IC1104	6-600-014-01	IC TORX141L (DIGITAL OPTICAL DVD IN)		R1109	1-216-864-11	SHORT CHIP	0
IC1105	6-600-014-01	IC TORX141L (DIGITAL OPTICAL TV/SAT IN)		R1110	1-216-821-11	METAL CHIP	1K 5% 1/10W
IC1106	6-600-014-01	IC TORX141L (DIGITAL OPTICAL MD IN)		R1111	1-216-821-11	METAL CHIP	1K 5% 1/10W
IC1107	6-600-012-01	IC TOTX141L (DIGITAL OPTICAL MD OUT)		R1112	1-216-809-11	METAL CHIP	100 5% 1/10W
IC1201	6-702-047-01	IC CXD9718Q		R1113	1-216-821-11	METAL CHIP	1K 5% 1/10W
IC1202	6-700-983-01	IC IS61LV6416-15T (ICSI)		R1114	1-216-809-11	METAL CHIP	100 5% 1/10W
IC1204	8-759-546-74	IC TC7WH157FU (TE12R)		R1115	1-216-833-11	METAL CHIP	10K 5% 1/10W
IC1401	8-759-560-56	IC PCM1800E/2K		R1116	1-218-285-11	METAL CHIP	75 5% 1/10W
IC1402	8-759-636-55	IC M5218AFP		R1117	1-216-817-11	METAL CHIP	470 5% 1/10W
IC1403	8-759-231-53	IC TA7805S		R1118	1-216-853-11	METAL CHIP	470K 5% 1/10W
IC1501	8-759-825-12	IC PCM1604Y/2K		R1119	1-216-841-11	METAL CHIP	47K 5% 1/10W
IC1502	8-759-825-13	IC PCM1748E/2K		R1120	1-216-809-11	METAL CHIP	100 5% 1/10W
IC1503	8-759-196-96	IC TC7SH08FU-TE85R		R1121	1-216-809-11	METAL CHIP	100 5% 1/10W
IC1504	8-759-546-74	IC TC7WH157FU (TE12R) (DA1000ES)		R1122	1-216-809-11	METAL CHIP	100 5% 1/10W
IC1521	8-759-636-55	IC M5218AFP		R1123	1-216-809-11	METAL CHIP	100 5% 1/10W
IC1541	8-759-636-55	IC M5218AFP		R1124	1-216-809-11	METAL CHIP	100 5% 1/10W
IC1561	8-759-636-55	IC M5218AFP		R1127	1-216-809-11	METAL CHIP	100 5% 1/10W
IC1581	8-759-636-55	IC M5218AFP		R1201	1-216-833-11	METAL CHIP	10K 5% 1/10W
IC1601	6-802-990-01	IC MB90478PF-G-148-BND					
IC1602	6-702-913-01	IC S-80929CNMC-G8ZT2G					
IC1604	8-759-641-86	IC BR24C16F-E2					

DIGITAL

Ref. No.	Part No.	Description	Remark	Ref. No.	Part No.	Description	Remark
R1202	1-216-809-11	METAL CHIP	100 5% 1/10W	R1542	1-216-837-11	METAL CHIP	22K 5% 1/10W
R1203	1-216-833-11	METAL CHIP	10K 5% 1/10W	R1543	1-216-821-11	METAL CHIP	1K 5% 1/10W
R1204	1-216-821-11	METAL CHIP	1K 5% 1/10W	R1544	1-216-845-11	METAL CHIP	100K 5% 1/10W
R1205	1-216-809-11	METAL CHIP	100 5% 1/10W	R1550	1-216-832-11	METAL CHIP	8.2K 5% 1/10W
R1206	1-216-809-11	METAL CHIP	100 5% 1/10W	R1551	1-216-823-11	METAL CHIP	1.5K 5% 1/10W
R1207	1-216-809-11	METAL CHIP	100 5% 1/10W	R1552	1-216-837-11	METAL CHIP	22K 5% 1/10W
R1208	1-216-809-11	METAL CHIP	100 5% 1/10W	R1553	1-216-821-11	METAL CHIP	1K 5% 1/10W
R1209	1-216-809-11	METAL CHIP	100 5% 1/10W	R1554	1-216-845-11	METAL CHIP	100K 5% 1/10W
R1210	1-216-833-11	METAL CHIP	10K 5% 1/10W	R1560	1-216-832-11	METAL CHIP	8.2K 5% 1/10W
R1212	1-216-813-11	METAL CHIP	220 5% 1/10W	R1561	1-216-823-11	METAL CHIP	1.5K 5% 1/10W
R1213	1-216-813-11	METAL CHIP	220 5% 1/10W	R1562	1-216-837-11	METAL CHIP	22K 5% 1/10W
R1214	1-216-813-11	METAL CHIP	220 5% 1/10W	R1563	1-216-821-11	METAL CHIP	1K 5% 1/10W
R1215	1-216-813-11	METAL CHIP	220 5% 1/10W	R1564	1-216-845-11	METAL CHIP	100K 5% 1/10W
R1216	1-216-813-11	METAL CHIP	220 5% 1/10W	R1570	1-216-832-11	METAL CHIP	8.2K 5% 1/10W
R1217	1-216-813-11	METAL CHIP	220 5% 1/10W	R1571	1-216-823-11	METAL CHIP	1.5K 5% 1/10W
R1218	1-216-813-11	METAL CHIP	220 5% 1/10W	R1572	1-216-837-11	METAL CHIP	22K 5% 1/10W
R1219	1-216-813-11	METAL CHIP	220 5% 1/10W	R1573	1-216-821-11	METAL CHIP	1K 5% 1/10W
R1220	1-216-813-11	METAL CHIP	220 5% 1/10W	R1574	1-216-845-11	METAL CHIP	100K 5% 1/10W
R1221	1-216-813-11	METAL CHIP	220 5% 1/10W	R1580	1-216-832-11	METAL CHIP	8.2K 5% 1/10W
R1222	1-216-813-11	METAL CHIP	220 5% 1/10W	R1581	1-216-823-11	METAL CHIP	1.5K 5% 1/10W
R1224	1-216-809-11	METAL CHIP	100 5% 1/10W	R1582	1-216-837-11	METAL CHIP	22K 5% 1/10W
R1226	1-216-864-11	SHORT CHIP	0	R1583	1-216-821-11	METAL CHIP	1K 5% 1/10W
R1304	1-216-841-11	METAL CHIP	47K 5% 1/10W	R1584	1-216-845-11	METAL CHIP	100K 5% 1/10W
R1305	1-216-841-11	METAL CHIP	47K 5% 1/10W	R1590	1-216-832-11	METAL CHIP	8.2K 5% 1/10W
R1308	1-216-821-11	METAL CHIP	1K 5% 1/10W				(DA1000ES)
R1314	1-216-864-11	SHORT CHIP	0	R1591	1-216-823-11	METAL CHIP	1.5K 5% 1/10W
R1364	1-216-864-11	SHORT CHIP	0				(DA1000ES)
R1401	1-216-821-11	METAL CHIP	1K 5% 1/10W	R1592	1-216-837-11	METAL CHIP	22K 5% 1/10W
R1402	1-216-825-11	METAL CHIP	2.2K 5% 1/10W				(DA1000ES)
R1421	1-216-839-11	METAL CHIP	33K 5% 1/10W	R1593	1-216-821-11	METAL CHIP	1K 5% 1/10W
R1422	1-216-839-11	METAL CHIP	33K 5% 1/10W				(DA1000ES)
R1424	1-216-845-11	METAL CHIP	100K 5% 1/10W	R1594	1-216-845-11	METAL CHIP	100K 5% 1/10W
R1431	1-216-839-11	METAL CHIP	33K 5% 1/10W				(DA1000ES)
R1432	1-216-839-11	METAL CHIP	33K 5% 1/10W	R1600	1-216-809-11	METAL CHIP	100 5% 1/10W
R1434	1-216-845-11	METAL CHIP	100K 5% 1/10W	R1601	1-216-821-11	METAL CHIP	1K 5% 1/10W
R1437	1-216-809-11	METAL CHIP	100 5% 1/10W	R1602	1-216-809-11	METAL CHIP	100 5% 1/10W
R1501	1-216-809-11	METAL CHIP	100 5% 1/10W	R1603	1-216-821-11	METAL CHIP	1K 5% 1/10W
R1502	1-216-809-11	METAL CHIP	100 5% 1/10W	R1604	1-216-809-11	METAL CHIP	100 5% 1/10W
R1503	1-216-809-11	METAL CHIP	100 5% 1/10W	R1605	1-216-809-11	METAL CHIP	100 5% 1/10W
R1504	1-216-833-11	METAL CHIP	10K 5% 1/10W	R1606	1-216-821-11	METAL CHIP	1K 5% 1/10W
R1505	1-216-809-11	METAL CHIP	100 5% 1/10W	R1607	1-216-821-11	METAL CHIP	1K 5% 1/10W
R1506	1-216-809-11	METAL CHIP	100 5% 1/10W	R1608	1-216-821-11	METAL CHIP	1K 5% 1/10W
R1507	1-216-809-11	METAL CHIP	100 5% 1/10W	R1609	1-216-821-11	METAL CHIP	1K 5% 1/10W
R1508	1-216-809-11	METAL CHIP	100 5% 1/10W	R1610	1-216-821-11	METAL CHIP	1K 5% 1/10W
R1509	1-216-809-11	METAL CHIP	100 5% 1/10W	R1611	1-216-821-11	METAL CHIP	1K 5% 1/10W
R1512	1-216-809-11	METAL CHIP	100 5% 1/10W	R1612	1-216-821-11	METAL CHIP	1K 5% 1/10W
R1520	1-216-832-11	METAL CHIP	8.2K 5% 1/10W	R1613	1-216-821-11	METAL CHIP	1K 5% 1/10W
R1521	1-216-823-11	METAL CHIP	1.5K 5% 1/10W	R1614	1-216-821-11	METAL CHIP	1K 5% 1/10W
R1522	1-216-837-11	METAL CHIP	22K 5% 1/10W	R1615	1-216-821-11	METAL CHIP	1K 5% 1/10W
R1523	1-216-821-11	METAL CHIP	1K 5% 1/10W	R1616	1-216-821-11	METAL CHIP	1K 5% 1/10W
R1524	1-216-845-11	METAL CHIP	100K 5% 1/10W	R1617	1-216-809-11	METAL CHIP	100 5% 1/10W
R1530	1-216-832-11	METAL CHIP	8.2K 5% 1/10W	R1618	1-216-809-11	METAL CHIP	100 5% 1/10W
R1531	1-216-823-11	METAL CHIP	1.5K 5% 1/10W	R1619	1-216-809-11	METAL CHIP	100 5% 1/10W
R1532	1-216-837-11	METAL CHIP	22K 5% 1/10W	R1620	1-216-809-11	METAL CHIP	100 5% 1/10W
R1533	1-216-821-11	METAL CHIP	1K 5% 1/10W	R1621	1-216-821-11	METAL CHIP	1K 5% 1/10W
R1534	1-216-845-11	METAL CHIP	100K 5% 1/10W	R1622	1-216-809-11	METAL CHIP	100 5% 1/10W
R1540	1-216-832-11	METAL CHIP	8.2K 5% 1/10W	R1623	1-216-821-11	METAL CHIP	1K 5% 1/10W
R1541	1-216-823-11	METAL CHIP	1.5K 5% 1/10W	R1624	1-216-833-11	METAL CHIP	10K 5% 1/10W

STR-DA1000ES/DB790

Ver 1.1

DIGITAL

DISPLAY

Ref. No.	Part No.	Description	Remark
R1625	1-216-833-11	METAL CHIP	10K 5% 1/10W
R1626	1-216-833-11	METAL CHIP	10K 5% 1/10W
R1627	1-216-833-11	METAL CHIP	10K 5% 1/10W
R1628	1-216-833-11	METAL CHIP	10K 5% 1/10W
R1629	1-216-809-11	METAL CHIP	100 5% 1/10W
R1630	1-216-821-11	METAL CHIP	1K 5% 1/10W
R1631	1-216-833-11	METAL CHIP	10K 5% 1/10W
R1632	1-216-809-11	METAL CHIP	100 5% 1/10W
R1633	1-216-809-11	METAL CHIP	100 5% 1/10W
R1634	1-216-841-11	METAL CHIP	47K 5% 1/10W (DB790)
R1635	1-216-833-11	METAL CHIP	10K 5% 1/10W
R1636	1-216-833-11	METAL CHIP	10K 5% 1/10W
R1637	1-216-809-11	METAL CHIP	100 5% 1/10W
R1638	1-216-809-11	METAL CHIP	100 5% 1/10W
R1639	1-216-821-11	METAL CHIP	1K 5% 1/10W
R1640	1-216-821-11	METAL CHIP	1K 5% 1/10W
R1641	1-216-821-11	METAL CHIP	1K 5% 1/10W
R1642	1-216-833-11	METAL CHIP	10K 5% 1/10W
R1643	1-216-821-11	METAL CHIP	1K 5% 1/10W
R1644	1-216-821-11	METAL CHIP	1K 5% 1/10W
R1645	1-216-821-11	METAL CHIP	1K 5% 1/10W
R1646	1-216-821-11	METAL CHIP	1K 5% 1/10W
R1647	1-216-821-11	METAL CHIP	1K 5% 1/10W
R1648	1-216-821-11	METAL CHIP	1K 5% 1/10W
R1649	1-216-821-11	METAL CHIP	1K 5% 1/10W
R1650	1-216-833-11	METAL CHIP	10K 5% 1/10W
R1651	1-216-833-11	METAL CHIP	10K 5% 1/10W
R1652	1-216-833-11	METAL CHIP	10K 5% 1/10W
R1653	1-216-833-11	METAL CHIP	10K 5% 1/10W
R1654	1-216-833-11	METAL CHIP	10K 5% 1/10W
R1655	1-216-833-11	METAL CHIP	10K 5% 1/10W
R1656	1-216-833-11	METAL CHIP	10K 5% 1/10W
R1657	1-216-833-11	METAL CHIP	10K 5% 1/10W
R1658	1-216-809-11	METAL CHIP	100 5% 1/10W
R1662	1-216-827-11	METAL CHIP	3.3K 5% 1/10W
R1663	1-216-827-11	METAL CHIP	3.3K 5% 1/10W
R1664	1-216-809-11	METAL CHIP	100 5% 1/10W
R1665	1-216-809-11	METAL CHIP	100 5% 1/10W
R1666	1-216-833-11	METAL CHIP	10K 5% 1/10W
R1667	1-216-821-11	METAL CHIP	1K 5% 1/10W
R1668	1-216-830-11	METAL CHIP	5.6K 5% 1/10W
R1669	1-216-829-11	METAL CHIP	4.7K 5% 1/10W
R1671	1-216-833-11	METAL CHIP	10K 5% 1/10W
R1672	1-216-797-11	METAL CHIP	10 5% 1/10W
R1673	1-216-821-11	METAL CHIP	1K 5% 1/10W
R1674	1-216-821-11	METAL CHIP	1K 5% 1/10W
R1675	1-216-833-11	METAL CHIP	10K 5% 1/10W
R1676	1-216-821-11	METAL CHIP	1K 5% 1/10W
R1677	1-216-821-11	METAL CHIP	1K 5% 1/10W
R1678	1-216-821-11	METAL CHIP	1K 5% 1/10W
R1679	1-216-821-11	METAL CHIP	1K 5% 1/10W
R1680	1-216-821-11	METAL CHIP	1K 5% 1/10W
R1681	1-216-821-11	METAL CHIP	1K 5% 1/10W
R1682	1-216-845-11	METAL CHIP	100K 5% 1/10W
R1687	1-216-833-11	METAL CHIP	10K 5% 1/10W
R1690	1-216-821-11	METAL CHIP	1K 5% 1/10W
R1691	1-216-833-11	METAL CHIP	10K 5% 1/10W

Ref. No.	Part No.	Description	Remark
R1692	1-216-841-11	METAL CHIP	47K 5% 1/10W
R1693	1-216-841-11	METAL CHIP	47K 5% 1/10W
R1694	1-216-821-11	METAL CHIP	1K 5% 1/10W
R1695	1-216-833-11	METAL CHIP	10K 5% 1/10W
R1697	1-216-825-11	METAL CHIP	2.2K 5% 1/10W (DB790: AEP, UK)
R1697	1-216-829-11	METAL CHIP	4.7K 5% 1/10W (DB790: SP, MY, TW, KR, AUS, CH)
R1697	1-216-864-11	SHORT CHIP	0 (DA1000ES)
R1698	1-216-809-11	METAL CHIP	100 5% 1/10W
R1699	1-216-809-11	METAL CHIP	100 5% 1/10W
R1701	1-216-833-11	METAL CHIP	10K 5% 1/10W
R1702	1-216-833-11	METAL CHIP	10K 5% 1/10W
R1703	1-216-833-11	METAL CHIP	10K 5% 1/10W
R1704	1-216-833-11	METAL CHIP	10K 5% 1/10W
R1705	1-216-809-11	METAL CHIP	100 5% 1/10W (DB790: AEP, UK)
R1710	1-216-809-11	METAL CHIP	100 5% 1/10W (DB790: AEP, UK)
R1711	1-216-809-11	METAL CHIP	100 5% 1/10W (DB790: AEP, UK)
R1712	1-216-833-11	METAL CHIP	10K 5% 1/10W
R1713	1-216-833-11	METAL CHIP	10K 5% 1/10W
R1714	1-216-833-11	METAL CHIP	10K 5% 1/10W
R1715	1-216-833-11	METAL CHIP	10K 5% 1/10W
R1716	1-216-833-11	METAL CHIP	10K 5% 1/10W
R1717	1-216-833-11	METAL CHIP	10K 5% 1/10W
R1718	1-216-833-11	METAL CHIP	10K 5% 1/10W
R1719	1-216-833-11	METAL CHIP	10K 5% 1/10W
R1720	1-216-833-11	METAL CHIP	10K 5% 1/10W
R1721	1-216-821-11	METAL CHIP	1K 5% 1/10W
< VIBRATOR >			
X1101	1-781-465-21	VIBRATOR, CRYSTAL (12.288MHz)	
X1201	1-781-527-21	VIBRATOR, CRYSTAL (13.5MHz)	
X1601	1-781-356-21	VIBRATOR, CERAMIC (16MHz)	

A-4733-524-A	DISPLAY BOARD, COMPLETE		

* 4-245-442-01	HOLDER (FL)		
* 4-921-941-01	CUSHION (FL)		
< CAPACITOR >			
C1005	1-127-888-11	CERAMIC	0.1uF 10% 50V
C1006	1-128-813-11	CERAMIC	220PF 5% 50V
C1007	1-128-813-11	CERAMIC	220PF 5% 50V
C1008	1-128-809-11	CERAMIC	100PF 5% 50V
C1009	1-127-888-11	CERAMIC	0.1uF 10% 50V
C1010	1-126-786-11	ELECT	47uF 20% 16V
C1011	1-127-888-11	CERAMIC	0.1uF 10% 50V
C1012	1-127-888-11	CERAMIC	0.1uF 10% 50V
C1013	1-127-888-11	CERAMIC	0.1uF 10% 50V
C1014	1-126-796-11	ELECT	22uF 20% 50V
C1015	1-128-813-11	CERAMIC	220PF 5% 50V
C1016	1-128-813-11	CERAMIC	220PF 5% 50V
C1017	1-128-813-11	CERAMIC	220PF 5% 50V
C1018	1-128-813-11	CERAMIC	220PF 5% 50V
C1019	1-128-813-11	CERAMIC	220PF 5% 50V

DISPLAY

FUN

HP-V3

Ref. No.	Part No.	Description	Remark	Ref. No.	Part No.	Description	Remark
C1020	1-128-813-11	CERAMIC	220PF 5% 50V			< ROTARY ENCODER >	
C1021	1-128-813-11	CERAMIC	220PF 5% 50V				
C1022	1-128-813-11	CERAMIC	220PF 5% 50V				
C1023	1-128-813-11	CERAMIC	220PF 5% 50V				
C1024	1-128-813-11	CERAMIC	220PF 5% 50V				
C1025	1-128-813-11	CERAMIC	220PF 5% 50V				
C1026	1-128-813-11	CERAMIC	220PF 5% 50V				
C1031	1-127-888-11	CERAMIC	0.1uF 10% 50V				
C1051	1-126-786-11	ELECT	47uF 20% 16V				
C1071	1-126-786-11	ELECT	47uF 20% 16V				
		< CONNECTOR >					
CN1001	1-784-749-11	CONNECTOR, FFC 27P					
CN1071	1-564-506-11	PLUG, CONNECTOR 3P					
		< DIODE >					
D1031	8-719-084-07	LED SEL5E20CTP15 (MULTI CHANNEL DECODING)					
D1071	8-719-118-63	DIODE RD5.6F-T7B2					
		< FLUORESCENT INDICATOR TUBE >					
FL1603	1-518-928-11	INDICATOR TUBE, FLUORESCENT					
		< IC >					
IC1001	8-759-643-83	IC uPD16315GB-3BS					
IC1006	8-759-243-51	IC TC74ACT08P					
IC1051	8-759-826-34	IC NJL74H400A					
		< TRANSISTOR >					
Q1031	8-729-119-76	TRANSISTOR 2SA1175-HFE					
Q1032	8-729-119-78	TRANSISTOR 2SC2785-HFE					
		< RESISTOR >					
R1004	1-249-437-11	CARBON	47K 5% 1/4W				
R1005	1-249-440-11	CARBON	82K 5% 1/4W				
R1009	1-249-437-11	CARBON	47K 5% 1/4W				
△R1011	1-249-381-11	CARBON	1 5% 1/4W F				
△R1012	1-249-381-11	CARBON	1 5% 1/4W F				
R1031	1-249-409-11	CARBON	220 5% 1/4W				
R1032	1-249-429-11	CARBON	10K 5% 1/4W				
R1033	1-249-402-11	CARBON	56 5% 1/4W				
R1035	1-249-429-11	CARBON	10K 5% 1/4W				
R1036	1-249-425-11	CARBON	4.7K 5% 1/4W				
R1037	1-249-425-11	CARBON	4.7K 5% 1/4W				
R1042	1-249-417-11	CARBON	1K 5% 1/4W				
R1043	1-249-421-11	CARBON	2.2K 5% 1/4W				
R1044	1-249-421-11	CARBON	2.2K 5% 1/4W				
R1045	1-249-425-11	CARBON	4.7K 5% 1/4W				
R1046	1-249-429-11	CARBON	10K 5% 1/4W				
R1047	1-249-433-11	CARBON	22K 5% 1/4W				
R1052	1-249-417-11	CARBON	1K 5% 1/4W				
R1053	1-249-421-11	CARBON	2.2K 5% 1/4W				
R1054	1-249-421-11	CARBON	2.2K 5% 1/4W				
R1055	1-249-425-11	CARBON	4.7K 5% 1/4W				
R1056	1-249-429-11	CARBON	10K 5% 1/4W				
R1058	1-249-393-11	CARBON	10 5% 1/4W				
R1059	1-247-807-31	CARBON	100 5% 1/4W				
		< CAPACITOR >					
C1081	1-127-888-11	CERAMIC	0.1uF 10% 50V				
C1096	1-127-868-11	CERAMIC	2200PF 10% 50V				
C1097	1-127-868-11	CERAMIC	2200PF 10% 50V				
C1098	1-127-868-11	CERAMIC	2200PF 10% 50V				
		< CONNECTOR >					
CN1081	1-784-922-11	PIN, CONNECTOR 5P					
CN1091	1-784-925-11	PIN, CONNECTOR 10P					
		< GROUND TERMINAL >					
* EP1086	1-537-738-21	TERMINAL, EARTH					
* EP1091	1-537-738-21	TERMINAL, EARTH					
		< IC >					
IC1081	6-600-219-01	IC GP1FM313R20F (DIGITAL OPTICAL)					
		< JACK/TERMINAL >					
J1086	1-815-313-11	JACK (PHONES)					
J1091	1-770-571-11	JACK BLOCK, PIN (L TYPE) 3P (VIDEO 3 INPUT VIDEO/AUDIO)					
J1092	1-784-808-11	TERMINAL, S (VIDEO 3 INPUT S-VIDEO)					
		< RESISTOR >					
R1081	1-247-807-31	CARBON	100 5% 1/4W				

The components identified by mark △ or dotted line with mark △ are critical for safety. Replace only with part number specified.

Les composants identifiés par une marque △ sont critiques pour la sécurité. Ne les remplacer que par une pièce portant le numéro spécifié.

以阴影和 △ 标志来识别的零部件, 在安全方面具有关键性。因此只能以规定号码的零部件来更换。

STR-DA1000ES/DB790

Ver 1.1

HP-V3 **MAIN**

Ref. No.	Part No.	Description	Remark
R1092	1-249-417-11	CARBON 1K 5%	1/4W
R1093	1-249-417-11	CARBON 1K 5%	1/4W
R1094	1-247-804-11	CARBON 75 5%	1/4W
R1095	1-247-804-11	CARBON 75 5%	1/4W
R1096	1-247-804-11	CARBON 75 5%	1/4W

A-4733-533-A MAIN BOARD, COMPLETE (DA1000ES)			
A-4733-553-A MAIN BOARD, COMPLETE (DB790: SP, MY, TW, KR, CH)			
A-4733-568-A MAIN BOARD, COMPLETE (DB790: AEP, UK, AUS)			

< CAPACITOR >			
C401	1-126-933-11	ELECT 100uF 20%	16V (DA1000ES)
C401	1-127-718-11	ELECT 100uF 20%	16V (DB790: SP, MY, TW, KR, CH)
C401	1-135-681-11	ELECT 100uF 25V	(DB790: AEP, UK, AUS)
C402	1-102-110-00	CERAMIC 220PF 10%	50V
C403	1-128-560-11	ELECT 22uF 20%	100V (DA1000ES)
C403	1-128-883-11	ELECT 22uF 20%	100V (DB790: SP, MY, TW, KR, CH)
C403	1-135-727-11	ELECT 22uF 100V	(DB790: AEP, UK, AUS)
C404	1-128-560-11	ELECT 22uF 20%	100V (DA1000ES)
C404	1-128-883-11	ELECT 22uF 20%	100V (DB790: SP, MY, TW, KR, CH)
C404	1-135-727-11	ELECT 22uF 100V	(DB790: AEP, UK, AUS)
C413	1-127-876-11	CERAMIC 0.01uF 10%	50V
C416	1-136-161-00	MYLAR 0.047uF 5%	50V
C417	1-136-165-00	MYLAR 0.1uF 5%	50V
C418	1-126-934-11	ELECT 220uF 20%	16V (DA1000ES)
C418	1-127-719-11	ELECT 220uF 20%	16V (DB790: SP, MY, TW, KR, CH)
C418	1-135-710-11	ELECT 220uF 16V	(DB790: AEP, UK, AUS)
C419	1-128-809-11	CERAMIC 100PF 5%	50V
C431	1-126-947-11	ELECT 47uF 20%	35V (DA1000ES)
C431	1-128-840-11	ELECT 47uF 20%	16V (DB790: SP, MY, TW, KR, CH)
C431	1-135-708-11	ELECT 47uF 16V	(DB790: AEP, UK, AUS)
C432	1-128-813-11	CERAMIC 220PF 5%	50V
C456	1-126-933-11	ELECT 100uF 20%	16V (DA1000ES)
C456	1-127-718-11	ELECT 100uF 20%	16V (DB790: SP, MY, TW, KR, CH)
C456	1-135-681-11	ELECT 100uF 25V	(DB790: AEP, UK, AUS)
C457	1-102-110-00	CERAMIC 220PF 10%	50V
C463	1-127-876-11	CERAMIC 0.01uF 10%	50V
C466	1-136-161-00	MYLAR 0.047uF 5%	50V
C467	1-136-165-00	MYLAR 0.1uF 5%	50V

Ref. No.	Part No.	Description	Remark
C468	1-126-934-11	ELECT 220uF 20%	16V (DA1000ES)
C468	1-127-719-11	ELECT 220uF 20%	16V (DB790: SP, MY, TW, KR, CH)
C468	1-135-710-11	ELECT 220uF 16V	(DB790: AEP, UK, AUS)
C481	1-126-947-11	ELECT 47uF 20%	35V (DA1000ES)
C481	1-128-840-11	ELECT 47uF 20%	16V (DB790: SP, MY, TW, KR, CH)
C481	1-135-708-11	ELECT 47uF 16V	(DB790: AEP, UK, AUS)
C482	1-128-813-11	CERAMIC 220PF 5%	50V
C501	1-126-933-11	ELECT 100uF 20%	16V (DA1000ES)
C501	1-127-718-11	ELECT 100uF 20%	16V (DB790: SP, MY, TW, KR, CH)
C501	1-135-681-11	ELECT 100uF 25V	(DB790: AEP, UK, AUS)
C502	1-102-110-00	CERAMIC 220PF 10%	50V
C513	1-127-876-11	CERAMIC 0.01uF 10%	50V
C516	1-136-161-00	MYLAR 0.047uF 5%	50V
C517	1-136-165-00	MYLAR 0.1uF 5%	50V
C518	1-126-934-11	ELECT 220uF 20%	16V (DA1000ES)
C518	1-127-719-11	ELECT 220uF 20%	16V (DB790: SP, MY, TW, KR, CH)
C518	1-135-710-11	ELECT 220uF 16V	(DB790: AEP, UK, AUS)
C519	1-128-809-11	CERAMIC 100PF 5%	50V
C531	1-126-947-11	ELECT 47uF 20%	35V (DA1000ES)
C531	1-128-840-11	ELECT 47uF 20%	16V (DB790: SP, MY, TW, KR, CH)
C531	1-135-708-11	ELECT 47uF 16V	(DB790: AEP, UK, AUS)
C532	1-128-813-11	CERAMIC 220PF 5%	50V
C551	1-126-933-11	ELECT 100uF 20%	16V (DA1000ES)
C551	1-127-718-11	ELECT 100uF 20%	16V (DB790: SP, MY, TW, KR, CH)
C551	1-135-681-11	ELECT 100uF 25V	(DB790: AEP, UK, AUS)
C552	1-102-110-00	CERAMIC 220PF 10%	50V
C563	1-127-876-11	CERAMIC 0.01uF 10%	50V
C566	1-136-161-00	MYLAR 0.047uF 5%	50V
C567	1-136-165-00	MYLAR 0.1uF 5%	50V
C568	1-126-934-11	ELECT 220uF 20%	16V (DA1000ES)
C568	1-127-719-11	ELECT 220uF 20%	16V (DB790: SP, MY, TW, KR, CH)
C568	1-135-710-11	ELECT 220uF 16V	(DB790: AEP, UK, AUS)
C581	1-126-947-11	ELECT 47uF 20%	35V (DA1000ES)
C581	1-128-840-11	ELECT 47uF 20%	16V (DB790: SP, MY, TW, KR, CH)
C581	1-135-708-11	ELECT 47uF 16V	(DB790: AEP, UK, AUS)
C582	1-128-813-11	CERAMIC 220PF 5%	50V
C601	1-126-933-11	ELECT 100uF 20%	16V (DA1000ES)

Ref. No.	Part No.	Description	Remark	Ref. No.	Part No.	Description	Remark
C601	1-127-718-11	ELECT	100uF 20% 16V (DB790: SP, MY, TW, KR, CH)	C751	1-127-718-11	ELECT	100uF 20% 16V (DB790: SP, MY, TW, KR, CH)
C601	1-135-681-11	ELECT	100uF 25V (DB790: AEP, UK, AUS)	C751	1-135-681-11	ELECT	100uF 25V (DB790: AEP, UK, AUS)
C602	1-102-110-00	CERAMIC	220PF 10% 50V	C752	1-102-110-00	CERAMIC	220PF 10% 50V
C613	1-127-876-11	CERAMIC	0.01uF 10% 50V	C753	1-126-933-11	ELECT	100uF 20% 16V (DA1000ES)
C616	1-136-161-00	MYLAR	0.047uF 5% 50V	C753	1-127-718-11	ELECT	100uF 20% 16V (DB790: SP, MY, TW, KR, CH)
C617	1-136-165-00	MYLAR	0.1uF 5% 50V	C753	1-135-681-11	ELECT	100uF 25V (DB790: AEP, UK, AUS)
C618	1-126-934-11	ELECT	220uF 20% 16V (DA1000ES)	C768	1-126-934-11	ELECT	220uF 20% 16V (DA1000ES)
C618	1-127-719-11	ELECT	220uF 20% 16V (DB790: SP, MY, TW, KR, CH)	C768	1-127-719-11	ELECT	220uF 20% 16V (DB790: SP, MY, TW, KR, CH)
C618	1-135-710-11	ELECT	220uF 16V (DB790: AEP, UK, AUS)	C768	1-135-710-11	ELECT	220uF 16V (DB790: AEP, UK, AUS)
C619	1-128-809-11	CERAMIC	100PF 5% 50V	C805	1-135-655-11	ELECT	470uF 6.3V
C631	1-126-947-11	ELECT	47uF 20% 35V (DA1000ES)	C807	1-126-965-11	ELECT	22uF 20% 50V
C631	1-128-840-11	ELECT	47uF 20% 16V (DB790: SP, MY, TW, KR, CH)	C812	1-127-868-11	CERAMIC	2200PF 10% 50V
C631	1-135-708-11	ELECT	47uF 16V (DB790: AEP, UK, AUS)	C813	1-127-868-11	CERAMIC	2200PF 10% 50V
C632	1-128-813-11	CERAMIC	220PF 5% 50V	C814	1-126-947-11	ELECT	47uF 20% 16V
C651	1-126-933-11	ELECT	100uF 20% 16V (DA1000ES)	C815	1-126-947-11	ELECT	47uF 20% 16V
C652	1-102-110-00	CERAMIC	220PF 10% 50V (DA1000ES)	C816	1-127-888-11	CERAMIC	0.1uF 10% 50V
C663	1-127-876-11	CERAMIC	0.01uF 10% 50V	C817	1-126-947-11	ELECT	47uF 20% 35V (DA1000ES)
C666	1-136-161-00	MYLAR	0.047uF 5% 50V	C817	1-128-850-11	ELECT	47uF 20% 35V (DB790: SP, MY, TW, KR, CH)
C667	1-136-165-00	MYLAR	0.1uF 5% 50V	C817	1-135-775-11	ELECT	47uF 35V (DB790: AEP, UK, AUS)
C668	1-126-934-11	ELECT	220uF 20% 16V (DA1000ES)	C818	1-128-551-11	ELECT	22uF 20% 63V (DA1000ES)
C669	1-128-809-11	CERAMIC	100PF 5% 50V	C818	1-128-858-11	ELECT	22uF 20% 50V (DB790: SP, MY, TW, KR, CH)
C681	1-126-947-11	ELECT	47uF 20% 35V (DA1000ES)	C818	1-135-703-11	ELECT	22uF 25V (DB790: AEP, UK, AUS)
C681	1-128-840-11	ELECT	47uF 20% 16V (DB790: SP, MY, TW, KR, CH)	C819	1-128-551-11	ELECT	22uF 20% 63V (DA1000ES)
C681	1-135-708-11	ELECT	47uF 16V (DB790: AEP, UK, AUS)	C819	1-128-858-11	ELECT	22uF 20% 50V (DB790: SP, MY, TW, KR, CH)
C682	1-128-813-11	CERAMIC	220PF 5% 50V	C819	1-135-703-11	ELECT	22uF 25V (DB790: AEP, UK, AUS)
C701	1-126-933-11	ELECT	100uF 20% 16V (DA1000ES)	C821	1-127-876-11	CERAMIC	0.01uF 10% 50V
C701	1-127-718-11	ELECT	100uF 20% 16V (DB790: SP, MY, TW, KR, CH)	C822	1-126-947-11	ELECT	47uF 20% 16V
C701	1-135-681-11	ELECT	100uF 25V (DB790: AEP, UK, AUS)	< CONNECTOR >			
C702	1-102-110-00	CERAMIC	220PF 10% 50V	CN401	1-770-382-11	CONNECTOR, BOARD TO BOARD 12P	
C713	1-127-876-11	CERAMIC	0.01uF 10% 50V (DA1000ES)	CN402	1-573-852-11	CONNECTOR, BOARD TO BOARD 20P	
C716	1-136-161-00	MYLAR	0.047uF 5% 50V (DA1000ES)	CN403	1-573-852-11	CONNECTOR, BOARD TO BOARD 20P	
C717	1-136-165-00	MYLAR	0.1uF 5% 50V (DA1000ES)	CN404	1-573-852-11	CONNECTOR, BOARD TO BOARD 20P	
C718	1-126-934-11	ELECT	220uF 20% 16V (DA1000ES)	CN405	1-573-852-11	CONNECTOR, BOARD TO BOARD 20P	
C718	1-127-719-11	ELECT	220uF 20% 16V (DB790: SP, MY, TW, KR, CH)	CN406	1-766-715-21	CONNECTOR, BOARD TO BOARD 10P	
C718	1-135-710-11	ELECT	220uF 16V (DB790: AEP, UK, AUS)	CN407	1-766-715-21	CONNECTOR, BOARD TO BOARD 10P	
C751	1-126-933-11	ELECT	100uF 20% 16V (DA1000ES)	CN408	1-766-715-21	CONNECTOR, BOARD TO BOARD 10P	
				CN408	1-766-715-21	CONNECTOR, BOARD TO BOARD 10P	
				* CN409	1-691-765-11	PLUG (MICRO CONNECTOR) 3P	
				CN411	1-770-010-21	CONNECTOR, BOARD TO BOARD 4P	
				CN412	1-770-722-11	CONNECTOR, BOARD TO BOARD 6P	
				CN413	1-770-010-21	CONNECTOR, BOARD TO BOARD 4P	
				CN416	1-564-320-00	PIN, CONNECTOR (3.96mm PITCH) 2P (DA1000ES)	

MAIN

Ref. No.	Part No.	Description	Remark	Ref. No.	Part No.	Description	Remark
CN417	1-779-978-11	PIN, CONNECTOR 3P		IC652	8-759-167-88	IC NJM4565D	
CN420	1-770-379-11	CONNECTOR, BOARD TO BOARD 6P		IC804	8-759-243-51	IC TC74ACT08P	
CN421	1-770-379-11	CONNECTOR, BOARD TO BOARD 6P		IC805	8-759-243-51	IC TC74ACT08P	
CN423	1-785-101-11	PIN, CONNECTOR (3.96mm PITCH) 3P		< TRANSISTOR >			
(DA1000ES)				Q401	8-729-141-30	TRANSISTOR	2SC3623A-LK
* CN432	1-564-704-11	PIN, CONNECTOR (SMALL TYPE) 2P		Q431	8-729-044-08	TRANSISTOR	2SD1915 (F) -T (TA).SO
* CN482	1-564-704-11	PIN, CONNECTOR (SMALL TYPE) 2P		Q432	8-729-140-82	TRANSISTOR	2SA988-PAFAEA
CN501	1-770-382-11	CONNECTOR, BOARD TO BOARD 12P		Q433	8-729-140-82	TRANSISTOR	2SA988-PAFAEA
* CN532	1-564-704-11	PIN, CONNECTOR (SMALL TYPE) 2P		Q451	8-729-141-30	TRANSISTOR	2SC3623A-LK
* CN582	1-564-704-11	PIN, CONNECTOR (SMALL TYPE) 2P		Q481	8-729-044-08	TRANSISTOR	2SD1915 (F) -T (TA).SO
CN601	1-770-379-11	CONNECTOR, BOARD TO BOARD 6P		Q482	8-729-140-82	TRANSISTOR	2SA988-PAFAEA
* CN632	1-564-704-11	PIN, CONNECTOR (SMALL TYPE) 2P		Q483	8-729-140-82	TRANSISTOR	2SA988-PAFAEA
CN651	1-770-381-11	CONNECTOR, BOARD TO BOARD 10P		Q501	8-729-141-30	TRANSISTOR	2SC3623A-LK
* CN682	1-564-704-11	PIN, CONNECTOR (SMALL TYPE) 2P		Q531	8-729-044-08	TRANSISTOR	2SD1915 (F) -T (TA).SO
< DIODE >				Q532	8-729-140-82	TRANSISTOR	2SA988-PAFAEA
D411	8-719-991-33	DIODE 1SS133T-77		Q533	8-729-140-82	TRANSISTOR	2SA988-PAFAEA
D431	8-719-991-33	DIODE 1SS133T-77		Q551	8-729-141-30	TRANSISTOR	2SC3623A-LK
D461	8-719-991-33	DIODE 1SS133T-77		Q581	8-729-044-08	TRANSISTOR	2SD1915 (F) -T (TA).SO
D481	8-719-991-33	DIODE 1SS133T-77		Q582	8-729-140-82	TRANSISTOR	2SA988-PAFAEA
D511	8-719-991-33	DIODE 1SS133T-77		Q583	8-729-140-82	TRANSISTOR	2SA988-PAFAEA
D531	8-719-991-33	DIODE 1SS133T-77		Q601	8-729-141-30	TRANSISTOR	2SC3623A-LK
D561	8-719-991-33	DIODE 1SS133T-77		Q631	8-729-044-08	TRANSISTOR	2SD1915 (F) -T (TA).SO
D581	8-719-991-33	DIODE 1SS133T-77		Q632	8-729-140-82	TRANSISTOR	2SA988-PAFAEA
D611	8-719-991-33	DIODE 1SS133T-77		Q633	8-729-140-82	TRANSISTOR	2SA988-PAFAEA
D631	8-719-991-33	DIODE 1SS133T-77		Q651	8-729-141-30	TRANSISTOR	2SC3623A-LK
D661	8-719-991-33	DIODE 1SS133T-77		Q681	8-729-044-08	TRANSISTOR	2SD1915 (F) -T (TA).SO
D681	8-719-991-33	DIODE 1SS133T-77		Q682	8-729-140-82	TRANSISTOR	2SA988-PAFAEA
D711	8-719-991-33	DIODE 1SS133T-77 (DA1000ES)		Q683	8-729-140-82	TRANSISTOR	2SA988-PAFAEA
D731	8-719-991-33	DIODE 1SS133T-77 (DA1000ES)		Q701	8-729-141-30	TRANSISTOR	2SC3623A-LK (DA1000ES)
D805	8-719-991-33	DIODE 1SS133T-77		Q732	8-729-140-82	TRANSISTOR	2SA988-PAFAEA(DA1000ES)
D807	8-719-991-33	DIODE 1SS133T-77		Q751	8-729-141-30	TRANSISTOR	2SC3623A-LK
D808	8-719-991-33	DIODE 1SS133T-77		Q802	8-729-119-78	TRANSISTOR	2SC2785-HFE
D810	8-719-991-33	DIODE 1SS133T-77		Q803	8-729-140-82	TRANSISTOR	2SA988-PAFAEA
D812	8-719-991-33	DIODE 1SS133T-77		Q805	8-729-140-84	TRANSISTOR	2SC1841-PAFAEA
D814	8-719-991-33	DIODE 1SS133T-77		Q807	8-729-119-79	TRANSISTOR	2SC2785-FEK
D815	8-719-985-88	DIODE HZS6B2LTA		Q808	8-729-119-79	TRANSISTOR	2SC2785-FEK
D816	8-719-991-33	DIODE 1SS133T-77		Q809	8-729-119-79	TRANSISTOR	2SC2785-FEK
D817	8-719-991-33	DIODE 1SS133T-77		Q810	8-729-900-63	TRANSISTOR	DTA124ES
D818	8-719-991-33	DIODE 1SS133T-77		Q811	8-729-119-79	TRANSISTOR	2SC2785-FEK
D819	8-719-991-33	DIODE 1SS133T-77		Q813	8-729-900-63	TRANSISTOR	DTA124ES
D820	8-719-991-33	DIODE 1SS133T-77		Q822	8-729-900-36	TRANSISTOR	DTC124ES
D821	8-719-110-56	DIODE RD22ESB1		Q823	8-729-119-79	TRANSISTOR	2SC2785-FEK
D822	8-719-110-56	DIODE RD22ESB1		Q824	8-729-119-78	TRANSISTOR	2SC2785-HFE
D823	8-719-922-45	DIODE MTZJ-T-73-5.6C		Q826	8-729-119-79	TRANSISTOR	2SC2785-FEK
< GROUND TERMINAL >				< RESISTOR >			
EB403	4-924-264-01	TERMINAL, MOUNT		R401	1-249-427-11	CARBON	6.8K 5% 1/4W
< IC >				R402	1-249-417-11	CARBON	1K 5% 1/4W
IC401	6-702-387-01	IC CXD9725M		R403	1-249-441-11	CARBON	100K 5% 1/4W
IC402	8-759-167-88	IC NJM4565D		R404	1-249-417-11	CARBON	1K 5% 1/4W
IC501	6-702-387-01	IC CXD9725M		△R412	1-249-405-11	CARBON	100 5% 1/4W F
IC502	8-759-167-88	IC NJM4565D		△R413	1-249-405-11	CARBON	100 5% 1/4W F
IC601	6-702-387-01	IC CXD9725M		△R414	1-234-182-11	ENCAPSULATED COMPONENT	0.22 5W F (DA1000ES)
IC602	8-759-167-88	IC NJM4565D		△R414	1-234-572-21	ENCAPSULATED COMPONENT	0.22 5W F (DB790)
IC651	6-702-387-01	IC CXD9725M		R415	1-249-437-11	CARBON	47K 5% 1/4W
				R416	1-249-441-11	CARBON	100K 5% 1/4W

The components identified by mark △ or dotted line with mark △ are critical for safety. Replace only with part number specified.	Les composants identifiés par une marque △ sont critiques pour la sécurité. Ne les remplacer que par une pièce portant le numéro spécifié.	以阴影和 △ 标志来识别的零部件，在安全方面具有关键性。因此只能以规定号码的零部件来更换。
--	--	---

Ref. No.	Part No.	Description	Remark	Ref. No.	Part No.	Description	Remark
△ R419	1-249-393-11	CARBON	10 5% 1/4W F	△ R564	1-234-572-21	ENCAPSULATED COMPONENT 0.22	5W F (DB790)
R431	1-249-414-11	CARBON	560 5% 1/4W	R565	1-249-437-11	CARBON	47K 5% 1/4W
R432	1-249-422-11	CARBON	2.7K 5% 1/4W	R566	1-249-441-11	CARBON	100K 5% 1/4W
△ R435	1-240-855-11	CARBON	6.2K 5% 1/4W F	△ R569	1-249-393-11	CARBON	10 5% 1/4W F
R436	1-249-425-11	CARBON	4.7K 5% 1/4W	R581	1-249-414-11	CARBON	560 5% 1/4W
R437	1-249-420-11	CARBON	1.8K 5% 1/4W	R582	1-249-422-11	CARBON	2.7K 5% 1/4W
R438	1-249-439-11	CARBON	68K 5% 1/4W	△ R585	1-240-855-11	CARBON	6.2K 5% 1/4W F
R439	1-249-431-11	CARBON	15K 5% 1/4W	R586	1-249-425-11	CARBON	4.7K 5% 1/4W
R443	1-249-437-11	CARBON	47K 5% 1/4W	R587	1-249-420-11	CARBON	1.8K 5% 1/4W
R451	1-249-427-11	CARBON	6.8K 5% 1/4W	R588	1-249-439-11	CARBON	68K 5% 1/4W
R457	1-249-417-11	CARBON	1K 5% 1/4W	R589	1-249-431-11	CARBON	15K 5% 1/4W
R458	1-249-441-11	CARBON	100K 5% 1/4W	R593	1-249-437-11	CARBON	47K 5% 1/4W
△ R462	1-249-405-11	CARBON	100 5% 1/4W F	R601	1-249-427-11	CARBON	6.8K 5% 1/4W
△ R463	1-249-405-11	CARBON	100 5% 1/4W F	R602	1-249-417-11	CARBON	1K 5% 1/4W
△ R464	1-234-182-11	ENCAPSULATED COMPONENT 0.22	5W F (DA1000ES)	R603	1-249-441-11	CARBON	100K 5% 1/4W
△ R464	1-234-572-21	ENCAPSULATED COMPONENT 0.22	5W F (DB790)	R604	1-249-417-11	CARBON	1K 5% 1/4W
R465	1-249-437-11	CARBON	47K 5% 1/4W	△ R612	1-249-405-11	CARBON	100 5% 1/4W F
R466	1-249-441-11	CARBON	100K 5% 1/4W	△ R613	1-249-405-11	CARBON	100 5% 1/4W F
△ R469	1-249-393-11	CARBON	10 5% 1/4W F	△ R614	1-234-182-11	ENCAPSULATED COMPONENT 0.22	5W F (DA1000ES)
R481	1-249-414-11	CARBON	560 5% 1/4W	△ R614	1-234-572-21	ENCAPSULATED COMPONENT 0.22	5W F (DB790)
R482	1-249-422-11	CARBON	2.7K 5% 1/4W	R615	1-249-437-11	CARBON	47K 5% 1/4W
△ R485	1-240-855-11	CARBON	6.2K 5% 1/4W F	R616	1-249-441-11	CARBON	100K 5% 1/4W
R486	1-249-425-11	CARBON	4.7K 5% 1/4W	△ R619	1-249-393-11	CARBON	10 5% 1/4W F
R487	1-249-420-11	CARBON	1.8K 5% 1/4W	R631	1-249-414-11	CARBON	560 5% 1/4W
R488	1-249-439-11	CARBON	68K 5% 1/4W	R632	1-249-422-11	CARBON	2.7K 5% 1/4W
R489	1-249-431-11	CARBON	15K 5% 1/4W	△ R635	1-240-855-11	CARBON	6.2K 5% 1/4W F
R493	1-249-437-11	CARBON	47K 5% 1/4W	R636	1-249-425-11	CARBON	4.7K 5% 1/4W
R501	1-249-427-11	CARBON	6.8K 5% 1/4W	R637	1-249-420-11	CARBON	1.8K 5% 1/4W
R502	1-249-417-11	CARBON	1K 5% 1/4W	R638	1-249-439-11	CARBON	68K 5% 1/4W
R503	1-249-441-11	CARBON	100K 5% 1/4W	R639	1-249-431-11	CARBON	15K 5% 1/4W
R504	1-249-417-11	CARBON	1K 5% 1/4W	R643	1-249-437-11	CARBON	47K 5% 1/4W
△ R512	1-249-405-11	CARBON	100 5% 1/4W F	R651	1-249-427-11	CARBON	6.8K 5% 1/4W
△ R513	1-249-405-11	CARBON	100 5% 1/4W F	R652	1-249-417-11	CARBON	1K 5% 1/4W (DA1000ES)
△ R514	1-234-182-11	ENCAPSULATED COMPONENT 0.22	5W F (DA1000ES)	R653	1-249-441-11	CARBON	100K 5% 1/4W (DA1000ES)
△ R514	1-234-572-21	ENCAPSULATED COMPONENT 0.22	5W F (DB790)	R654	1-249-417-11	CARBON	1K 5% 1/4W
R515	1-249-437-11	CARBON	47K 5% 1/4W	△ R662	1-249-405-11	CARBON	100 5% 1/4W F
R516	1-249-441-11	CARBON	100K 5% 1/4W	△ R663	1-249-405-11	CARBON	100 5% 1/4W F
△ R519	1-249-393-11	CARBON	10 5% 1/4W F	△ R664	1-234-182-11	ENCAPSULATED COMPONENT 0.22	5W F (DA1000ES)
R531	1-249-414-11	CARBON	560 5% 1/4W	△ R664	1-234-572-21	ENCAPSULATED COMPONENT 0.22	5W F (DB790)
R532	1-249-422-11	CARBON	2.7K 5% 1/4W	R665	1-249-437-11	CARBON	47K 5% 1/4W
△ R535	1-240-855-11	CARBON	6.2K 5% 1/4W F	R666	1-249-441-11	CARBON	100K 5% 1/4W
R536	1-249-425-11	CARBON	4.7K 5% 1/4W	△ R669	1-249-393-11	CARBON	10 5% 1/4W F
R537	1-249-420-11	CARBON	1.8K 5% 1/4W	R681	1-249-414-11	CARBON	560 5% 1/4W
R538	1-249-439-11	CARBON	68K 5% 1/4W	R682	1-249-422-11	CARBON	2.7K 5% 1/4W
R539	1-249-431-11	CARBON	15K 5% 1/4W	△ R685	1-240-855-11	CARBON	6.2K 5% 1/4W F
R543	1-249-437-11	CARBON	47K 5% 1/4W	R686	1-249-425-11	CARBON	4.7K 5% 1/4W
R551	1-249-427-11	CARBON	6.8K 5% 1/4W	R687	1-249-420-11	CARBON	1.8K 5% 1/4W
R552	1-249-417-11	CARBON	1K 5% 1/4W	R688	1-249-439-11	CARBON	68K 5% 1/4W
R553	1-249-441-11	CARBON	100K 5% 1/4W	R689	1-249-431-11	CARBON	15K 5% 1/4W
△ R562	1-249-405-11	CARBON	100 5% 1/4W F	R693	1-249-437-11	CARBON	47K 5% 1/4W
△ R563	1-249-405-11	CARBON	100 5% 1/4W F	R701	1-249-427-11	CARBON	6.8K 5% 1/4W (DA1000ES)
△ R564	1-234-182-11	ENCAPSULATED COMPONENT 0.22	5W F (DA1000ES)				

The components identified by mark △ or dotted line with mark △ are critical for safety. Replace only with part number specified.

Les composants identifiés par une marque △ sont critiques pour la sécurité. Ne les remplacer que par une pièce portant le numéro spécifié.

以阴影和 △ 标志来识别的零部件，在安全方面具有关键性。因此只能以规定号码的零部件来更换。

STR-DA1000ES/DB790

MAIN **PRI** **S-VIDEO**

Ref. No.	Part No.	Description	Remark
R702	1-249-417-11	CARBON 1K	5% 1/4W
R703	1-249-441-11	CARBON 100K	5% 1/4W
R715	1-249-437-11	CARBON 47K	5% 1/4W
R716	1-249-441-11	CARBON 100K	5% 1/4W (DA1000ES)
△R719	1-249-393-11	CARBON 10	5% 1/4W F (DA1000ES)
R738	1-249-439-11	CARBON 68K	5% 1/4W (DA1000ES)
R739	1-249-431-11	CARBON 15K	5% 1/4W (DA1000ES)
R743	1-249-437-11	CARBON 47K	5% 1/4W (DA1000ES)
R751	1-249-427-11	CARBON 6.8K	5% 1/4W
R752	1-249-417-11	CARBON 1K	5% 1/4W
R753	1-249-441-11	CARBON 100K	5% 1/4W
R782	1-249-441-11	CARBON 100K	5% 1/4W
R802	1-249-417-11	CARBON 1K	5% 1/4W
R805	1-249-429-11	CARBON 10K	5% 1/4W
R806	1-249-433-11	CARBON 22K	5% 1/4W
R807	1-249-429-11	CARBON 10K	5% 1/4W
R812	1-249-421-11	CARBON 2.2K	5% 1/4W
R813	1-249-421-11	CARBON 2.2K	5% 1/4W
R814	1-249-421-11	CARBON 2.2K	5% 1/4W
R815	1-249-429-11	CARBON 10K	5% 1/4W
R816	1-249-429-11	CARBON 10K	5% 1/4W
R817	1-249-429-11	CARBON 10K	5% 1/4W
R818	1-249-429-11	CARBON 10K	5% 1/4W
R820	1-249-421-11	CARBON 2.2K	5% 1/4W
R821	1-249-429-11	CARBON 10K	5% 1/4W
△R824	1-215-867-00	METAL OXIDE 470	5% 1W F
△R825	1-215-867-00	METAL OXIDE 470	5% 1W F
R826	1-247-903-00	CARBON 1M	5% 1/4W
R827	1-249-417-11	CARBON 1K	5% 1/4W
R828	1-249-425-11	CARBON 4.7K	5% 1/4W
△R829	1-249-393-11	CARBON 10	5% 1/4W F
R833	1-247-903-00	CARBON 1M	5% 1/4W
R838	1-249-421-11	CARBON 2.2K	5% 1/4W
R839	1-249-429-11	CARBON 10K	5% 1/4W
△R841	1-249-399-11	CARBON 33	5% 1/4W F
△R846	1-249-399-11	CARBON 33	5% 1/4W F
R847	1-249-421-11	CARBON 2.2K	5% 1/4W
R848	1-249-429-11	CARBON 10K	5% 1/4W
△R849	1-249-393-11	CARBON 10	5% 1/4W F
R850	1-249-429-11	CARBON 10K	5% 1/4W
R851	1-249-427-11	CARBON 6.8K	5% 1/4W
R852	1-249-433-11	CARBON 22K	5% 1/4W
R853	1-249-433-11	CARBON 22K	5% 1/4W
< VARIABLE RESISTOR >			
RV431	1-238-597-11	RES, ADJ, CARBON 1K	
RV481	1-238-597-11	RES, ADJ, CARBON 1K	
RV531	1-238-597-11	RES, ADJ, CARBON 1K	
RV581	1-238-597-11	RES, ADJ, CARBON 1K	
RV631	1-238-597-11	RES, ADJ, CARBON 1K	
RV681	1-238-597-11	RES, ADJ, CARBON 1K	

Ref. No.	Part No.	Description	Remark
< RELAY >			
RY806	1-515-920-11	RELAY (24V)	
RY807	1-755-483-11	RELAY	

	1-689-173-11	PRI BOARD	

< CONNECTOR >			
* CN3	1-565-792-11	PIN, CONNECTOR (3.96mm PITCH) 2P	

	A-4733-530-A	S-VIDEO BOARD, COMPLETE (DA1000ES)	
	A-4733-550-A	S-VIDEO BOARD, COMPLETE (DB790)	

< CAPACITOR >			
C850	1-128-805-11	CERAMIC 47PF 5% 50V	
C851	1-128-805-11	CERAMIC 47PF 5% 50V	
C852	1-128-805-11	CERAMIC 47PF 5% 50V	
C853	1-128-805-11	CERAMIC 47PF 5% 50V	
C854	1-128-825-11	CERAMIC 2200PF 5% 50V	
C855	1-136-165-00	MYLAR 0.1uF 5% 50V	
C856	1-136-165-00	MYLAR 0.1uF 5% 50V	
C857	1-136-165-00	MYLAR 0.1uF 5% 50V	
C858	1-126-964-11	ELECT 10uF 20% 50V	
C859	1-126-964-11	ELECT 10uF 20% 50V	
C860	1-126-964-11	ELECT 10uF 20% 50V	
C861	1-128-825-11	CERAMIC 2200PF 5% 50V	
C862	1-128-825-11	CERAMIC 2200PF 5% 50V	
C863	1-127-888-11	CERAMIC 0.1uF 10% 50V	
C864	1-136-165-00	MYLAR 0.1uF 5% 50V	
C867	1-127-888-11	CERAMIC 0.1uF 10% 50V	
C869	1-127-888-11	CERAMIC 0.1uF 10% 50V	
C870	1-126-964-11	ELECT 10uF 20% 50V	
C872	1-127-888-11	CERAMIC 0.1uF 10% 50V	
C877	1-127-888-11	CERAMIC 0.1uF 10% 50V	
(DA1000ES)			
C878	1-126-916-11	ELECT 1000uF 20% 6.3V	
(DA1000ES)			
C879	1-126-960-11	ELECT 1uF 20% 50V	
(DA1000ES)			
C890	1-104-665-11	ELECT 100uF 20% 25V	
(DA1000ES)			
< CONNECTOR >			
CN851	1-766-719-41	CONNECTOR, BOARD TO BOARD 10P	
* CN853	1-564-720-11	PIN, CONNECTOR (SMALL TYPE) 4P	
CN854	1-573-825-11	CONNECTOR, BOARD TO BOARD 11P	
< DIODE >			
D850	8-719-991-33	DIODE 1SS133T-77	
D851	8-719-991-33	DIODE 1SS133T-77	
D852	8-719-991-33	DIODE 1SS133T-77 (DA1000ES)	
D853	8-719-991-33	DIODE 1SS133T-77 (DA1000ES)	
< IC >			
IC850	6-701-890-01	IC NJM2595D	
IC851	6-701-890-01	IC NJM2595D	

The components identified by mark △ or dotted line with mark △ are critical for safety. Replace only with part number specified.	Les composants identifiés par une marque △ sont critiques pour la sécurité. Ne les remplacer que par une pièce portant le numéro spécifié.	以阴影和 △ 标志来识别的零部件，在安全方面具有关键性。因此只能以规定号码的零部件来更换。
--	--	---

S-VIDEO

SBL

SEC1

Ref. No.	Part No.	Description	Remark	Ref. No.	Part No.	Description	Remark
IC852	8-759-822-05	IC LA7213 (DA1000ES)				< DIODE >	
		< JACK >					
J850	1-794-937-11	CONNECTOR (DIN) 2P (VIDEO S-VIDEO DVD IN, TV/SAT IN)		D2701	8-719-109-89	DIODE RD5.6ESB2	
J851	1-537-943-11	CONNECTOR (DIN) 1P (VIDEO S-VIDEO MONITOR OUT)				< TRANSISTOR >	
J852	1-794-937-11	CONNECTOR (DIN) 2P (VIDEO S-VIDEO VIDEO 1 IN/OUT)		Q731	8-729-044-08	TRANSISTOR 2SD1915 (F) -T (TA).SO	
		< TRANSISTOR >		Q733	8-729-140-82	TRANSISTOR 2SA988-PAFAEA	
Q850	8-729-030-02	TRANSISTOR DTC144ESA (DA1000ES)		Q2701	8-729-045-15	TRANSISTOR 2SC5169-FG	
Q851	8-729-201-53	TRANSISTOR 2SA1015TP-YGR (DA1000ES)		Q2703	8-729-119-78	TRANSISTOR 2SC2785-HFE	
		< RESISTOR >		Q2704	8-729-199-22	TRANSISTOR 2SA992-FA	
R854	1-247-804-11	CARBON 75 5% 1/4W		Q2705	8-729-021-74	TRANSISTOR 2SA949-0Y	
R855	1-247-804-11	CARBON 75 5% 1/4W		Q2706	8-729-021-73	TRANSISTOR 2SC2229-0Y	
R856	1-247-804-11	CARBON 75 5% 1/4W				< RESISTOR >	
R857	1-247-804-11	CARBON 75 5% 1/4W		△R712	1-249-405-11	CARBON 100 5% 1/4W F	
R858	1-247-804-11	CARBON 75 5% 1/4W		△R713	1-249-405-11	CARBON 100 5% 1/4W F	
R859	1-247-804-11	CARBON 75 5% 1/4W		△R714	1-234-182-11	ENCAPSULATED COMPONENT 0.22 5W F	
R860	1-247-804-11	CARBON 75 5% 1/4W		R731	1-249-414-11	CARBON 560 5% 1/4W	
R861	1-247-804-11	CARBON 75 5% 1/4W		R732	1-249-422-11	CARBON 2.7K 5% 1/4W	
R862	1-247-804-11	CARBON 75 5% 1/4W		△R735	1-240-855-11	CARBON 6.2K 5% 1/4W F	
R863	1-247-804-11	CARBON 75 5% 1/4W		R736	1-249-425-11	CARBON 4.7K 5% 1/4W	
R864	1-247-883-00	CARBON 150K 5% 1/4W (DA1000ES)		R737	1-249-420-11	CARBON 1.8K 5% 1/4W	
R865	1-249-411-11	CARBON 330 5% 1/4W (DA1000ES)		R2701	1-249-417-11	CARBON 1K 5% 1/4W	
R866	1-249-421-11	CARBON 2.2K 5% 1/4W (DA1000ES)		R2702	1-249-438-11	CARBON 56K 5% 1/4W	
R867	1-249-429-11	CARBON 10K 5% 1/4W (DA1000ES)		R2703	1-249-411-11	CARBON 330 5% 1/4W	
		< RELAY >		R2704	1-249-418-11	CARBON 1.2K 5% 1/4W	
RY850	1-755-359-11	RELAY (DA1000ES)		R2705	1-249-425-11	CARBON 4.7K 5% 1/4W	
*****				R2706	1-249-418-11	CARBON 1.2K 5% 1/4W	
	A-4733-518-A	SBL BOARD, COMPLETE (DA1000ES)		R2707	1-249-414-11	CARBON 560 5% 1/4W	
		*****		R2708	1-247-843-11	CARBON 3.3K 5% 1/4W	
		< CAPACITOR >		R2709	1-249-560-31	CARBON 2.2K 5% 1/4W	
C731	1-126-947-11	ELECT 47uF 20% 35V		R2710	1-249-594-31	CARBON 56K 5% 1/4W	
C732	1-128-813-11	CERAMIC 220PF 5% 50V		R2711	1-249-441-11	CARBON 100K 5% 1/4W	
C2701	1-137-505-11	FILM 220PF 5% 100V		R2712	1-249-441-11	CARBON 100K 5% 1/4W	
C2702	1-128-551-11	ELECT 22uF 20% 63V		△R2713	1-249-413-11	CARBON 470 5% 1/4W F	
C2704	1-126-934-11	ELECT 220uF 20% 16V		△R2714	1-249-406-11	CARBON 120 5% 1/4W F	
		< CONNECTOR >		△R2715	1-249-406-11	CARBON 120 5% 1/4W F	
C2705	1-126-940-11	ELECT 330uF 20% 25V		R2716	1-249-435-11	CARBON 33K 5% 1/4W	
C2706	1-102-230-00	CERAMIC 4PF 0.25PF 500V		△R2717	1-249-393-11	CARBON 10 5% 1/4W F	
C2707	1-102-233-00	CERAMIC 33PF 10% 500V		△R2718	1-249-393-11	CARBON 10 5% 1/4W F	
C2708	1-137-383-11	MYLAR 220PF 5% 100V		R2719	1-249-407-11	CARBON 150 5% 1/4W	
C2807	1-128-582-11	ELECT 10uF 20% 100V				< VARIABLE RESISTOR >	
C2808	1-128-582-11	ELECT 10uF 20% 100V		RV731	1-238-597-11	RES, ADJ, CARBON 1K	
		< CONNECTOR >		*****			
CN732	1-564-718-11	PIN, CONNECTOR (SMALL TYPE) 2P			1-689-174-11	SEC1 BOARD	
CN2701	1-778-227-41	CONNECTOR, BOARD TO BOARD 6P				*****	
CN2703	1-770-011-41	CONNECTOR, BOARD TO BOARD 4P				< CONNECTOR >	
		< CONNECTOR >		CN52	1-785-103-11	PIN, CONNECTOR (3.96mm PITCH) 5P	
		< CONNECTOR >		CN53	1-691-765-31	PLUG (MICRO CONNECTOR) 3P	
		< CONNECTOR >		*****			

The components identified by mark △ or dotted line with mark △ are critical for safety. Replace only with part number specified.

Les composants identifiés par une marque △ sont critiques pour la sécurité. Ne les remplacer que par une pièce portant le numéro spécifié.

以阴影和 △标志来识别的零部件，在安全方面具有关键性。因此只能以规定号码的零部件来更换。

STR-DA1000ES/DB790

SEC3 SP-A SP-B

Ref. No.	Part No.	Description	Remark
	1-689-176-11	SEC3 BOARD *****	
		< CONNECTOR >	
CN57	1-691-766-11	PLUG (MICRO CONNECTOR) 4P	
CN58	1-691-765-11	PLUG (MICRO CONNECTOR) 3P	

	1-688-636-11	SP-A BOARD *****	
		< CAPACITOR >	
C443	1-127-872-11	CERAMIC 4700PF 10% 50V (DB790)	
C444	1-128-809-11	CERAMIC 100PF 5% 50V (DA1000ES)	
C444	1-128-817-11	CERAMIC 470PF 5% 50V (DB790)	
C448	1-128-809-11	CERAMIC 100PF 5% 50V (DA1000ES)	
C448	1-128-817-11	CERAMIC 470PF 5% 50V (DB790)	
C449	1-127-872-11	CERAMIC 4700PF 10% 50V (DB790)	
C493	1-127-872-11	CERAMIC 4700PF 10% 50V (DB790)	
C498	1-128-809-11	CERAMIC 100PF 5% 50V (DA1000ES)	
C498	1-128-817-11	CERAMIC 470PF 5% 50V (DB790)	
C499	1-127-872-11	CERAMIC 4700PF 10% 50V (DB790)	
C548	1-128-809-11	CERAMIC 100PF 5% 50V (DA1000ES)	
C548	1-128-817-11	CERAMIC 470PF 5% 50V (DB790)	
C549	1-127-872-11	CERAMIC 4700PF 10% 50V (DB790)	
C598	1-128-809-11	CERAMIC 100PF 5% 50V (DA1000ES)	
C598	1-128-817-11	CERAMIC 470PF 5% 50V (DB790)	
C599	1-127-872-11	CERAMIC 4700PF 10% 50V (DB790)	
C698	1-128-809-11	CERAMIC 100PF 5% 50V (DA1000ES)	
C698	1-128-817-11	CERAMIC 470PF 5% 50V (DB790)	
		< CONNECTOR >	
CN447	1-770-011-41	CONNECTOR, BOARD TO BOARD 4P	
CN448	1-770-011-41	CONNECTOR, BOARD TO BOARD 4P	
* CN449	1-770-727-11	CONNECTOR, BOARD TO BOARD 8P	
CN450	1-770-011-41	CONNECTOR, BOARD TO BOARD 4P	
		< DIODE >	
D444	8-719-991-33	DIODE 1SS133T-77	
D449	8-719-991-33	DIODE 1SS133T-77	
D549	8-719-991-33	DIODE 1SS133T-77	

Ref. No.	Part No.	Description	Remark
		< COIL >	
L449	1-420-872-52	COIL, AIR-CORE	
L499	1-420-872-52	COIL, AIR-CORE	
L549	1-420-872-52	COIL, AIR-CORE	
L599	1-420-872-52	COIL, AIR-CORE	
		< RESISTOR >	
△ R443	1-249-393-11	CARBON 10 5% 1/4W F (DB790)	
△ R444	1-249-393-11	CARBON 10 5% 1/4W F	
△ R447	1-249-393-11	CARBON 10 5% 1/4W F	
△ R448	1-249-393-11	CARBON 10 5% 1/4W F (DB790)	
△ R449	1-249-393-11	CARBON 10 5% 1/4W F	
△ R493	1-249-393-11	CARBON 10 5% 1/4W F (DB790)	
△ R498	1-249-393-11	CARBON 10 5% 1/4W F (DB790)	
△ R499	1-249-393-11	CARBON 10 5% 1/4W F	
△ R547	1-249-393-11	CARBON 10 5% 1/4W F	
△ R548	1-249-393-11	CARBON 10 5% 1/4W F (DB790)	
△ R549	1-249-393-11	CARBON 10 5% 1/4W F	
△ R598	1-249-393-11	CARBON 10 5% 1/4W F (DB790)	
△ R599	1-249-393-11	CARBON 10 5% 1/4W F	
		< RELAY >	
RY444	1-515-920-11	RELAY (24V)	
RY449	1-515-920-11	RELAY (24V)	
RY549	1-515-920-11	RELAY (24V)	
		< TERMINAL >	
TM449	1-780-033-11	TERMINAL BOARD (SP) (8P) (SPEAKERS FRONT B, SURR) (DA1000ES)	
TM449	1-780-033-21	TERMINAL BOARD (SP) (8P) (SPEAKERS FRONT B, SURR) (DB790)	
TM699	1-694-933-12	TERMINAL BOARD (SP) (4P) (SPEAKERS FRONT A) (DA1000ES)	
TM699	1-694-933-21	TERMINAL BOARD (SP) (4P) (SPEAKERS FRONT A) (DB790)	

	1-688-637-11	SP-B BOARD *****	
		< CAPACITOR >	
C210	1-127-868-11	CERAMIC 2200PF 10% 50V	
C494	1-128-809-11	CERAMIC 100PF 5% 50V (DA1000ES)	
C494	1-128-817-11	CERAMIC 470PF 5% 50V (DB790)	
C648	1-128-809-11	CERAMIC 100PF 5% 50V (DA1000ES)	
C699	1-127-872-11	CERAMIC 4700PF 10% 50V (DB790)	
C748	1-128-809-11	CERAMIC 100PF 5% 50V (DA1000ES)	
C748	1-128-817-11	CERAMIC 470PF 5% 50V (DB790)	

The components identified by mark △ or dotted line with mark △ are critical for safety. Replace only with part number specified.	Les composants identifiés par une marque △ sont critiques pour la sécurité. Ne les remplacer que par une pièce portant le numéro spécifié.	以阴影和 △标志来识别的零部件，在安全方面具有关键性。因此只能以规定号码的零部件来更换。
--	--	--

SP-B **STAY** **STAY2** **STAY3** **STAY4** **TH** **VIDEO**

Ref. No.	Part No.	Description	Remark	Ref. No.	Part No.	Description	Remark
C749	1-127-872-11	CERAMIC	4700PF 10% 50V (DB790)	1-689-748-11	STAY3 BOARD *****		
		< CONNECTOR >			< CONNECTOR >		
CN443	1-770-011-41	CONNECTOR, BOARD TO BOARD 4P		CN2706	1-770-011-41	CONNECTOR, BOARD TO BOARD 4P	
CN444	1-770-726-11	CONNECTOR, BOARD TO BOARD 6P		CN2707	1-770-011-41	CONNECTOR, BOARD TO BOARD 4P	
CN451	1-770-011-41	CONNECTOR, BOARD TO BOARD 4P		*****			
		< DIODE >		1-689-784-11	STAY4 BOARD *****		
D649	8-719-991-33	DIODE 1SS133T-77 (DA1000ES)			< CONNECTOR >		
D699	8-719-991-33	DIODE 1SS133T-77					
		< JACK >		CN452	1-770-011-41	CONNECTOR, BOARD TO BOARD 4P	
J203	1-770-377-31	JACK, PIN 1P (SUB WOOFER)		CN453	1-770-011-41	CONNECTOR, BOARD TO BOARD 4P	
		< COIL >		*****			
L649	1-420-872-52	COIL, AIR-CORE (DA1000ES)			TH BOARD *****		
L699	1-420-872-52	COIL, AIR-CORE			< CONNECTOR >		
L749	1-420-872-52	COIL, AIR-CORE		CN911	1-564-704-11	PIN, CONNECTOR (SMALL TYPE) 2P	
		< RESISTOR >			< THERMISTOR >		
R209	1-249-417-11	CARBON	1K 5% 1/4W	THP901	1-817-728-11	SENSOR, THERMISTOR	
△R648	1-249-393-11	CARBON	10 5% 1/4W F (DA1000ES)	*****			
△R649	1-249-393-11	CARBON	10 5% 1/4W F (DA1000ES)	1-688-645-11	VIDEO BOARD *****		
△R697	1-249-393-11	CARBON	10 5% 1/4W F		< CAPACITOR >		
△R698	1-249-393-11	CARBON	10 5% 1/4W F (DB790)	C301	1-128-805-11	CERAMIC	47PF 5% 50V
△R699	1-249-393-11	CARBON	10 5% 1/4W F	C302	1-127-868-11	CERAMIC	2200PF 10% 50V
△R748	1-249-393-11	CARBON	10 5% 1/4W F (DB790)	C303	1-126-964-11	ELECT	10uF 20% 50V
△R749	1-249-393-11	CARBON	10 5% 1/4W F	C304	1-127-868-11	CERAMIC	2200PF 10% 50V
		< RELAY >		C305	1-128-805-11	CERAMIC	47PF 5% 50V
RY649	1-515-920-11	RELAY (24V) (DA1000ES)		C306	1-126-964-11	ELECT	10uF 20% 50V
RY699	1-515-920-11	RELAY (24V)		C307	1-128-805-11	CERAMIC	47PF 5% 50V
		< TERMINAL >		C308	1-127-868-11	CERAMIC	2200PF 10% 50V
TM444	1-694-933-21	TERMINAL BOARD (SP) (4P) (SPEAKERS CENTER, SURROUND BACK) (DB790)		C309	1-126-964-11	ELECT	10uF 20% 50V
TM444	1-780-038-11	TERMINAL BOARD (SP) (6P) (SPEAKERS CENTER, SURR BACK) (DA1000ES)		C310	1-126-964-11	ELECT	10uF 20% 50V
*****				C311	1-127-888-11	CERAMIC	0.1uF 10% 50V
	1-689-177-11	STAY BOARD (DB790) *****		C313	1-126-964-11	ELECT	10uF 20% 50V
		< CONNECTOR >		C315	1-127-888-11	CERAMIC	0.1uF 10% 50V
CN2704	1-778-227-41	CONNECTOR, BOARD TO BOARD 6P		*****			
*****					< CONNECTOR >		
	1-689-747-11	STAY2 BOARD (DB790) *****		CN301	1-766-719-41	CONNECTOR, BOARD TO BOARD 10P	
		< CONNECTOR >			< DIODE >		
				D301	8-719-991-33	DIODE 1SS133T-77	
				D302	8-719-991-33	DIODE 1SS133T-77	
					< IC >		
				IC301	6-701-890-01	IC NJM2595D	
					< JACK >		
CN2705	1-770-011-41	CONNECTOR, BOARD TO BOARD 4P		J302	1-794-970-11	JACK, PIN 1P (VIDEO MONITOR OUT)	
*****				J304	1-794-978-11	JACK, PIN 3P (VIDEO VIDEO 1 IN, VIDEO 1 OUT, VIDEO 2 IN)	

The components identified by mark △ or dotted line with mark △ are critical for safety. Replace only with part number specified.	Les composants identifiés par une marque △ sont critiques pour la sécurité. Ne les remplacer que par une pièce portant le numéro spécifié.	以阴影和 △ 标志来识别的零部件，在安全方面具有关键性。因此只能以规定号码的零部件来更换。
--	--	---

STR-DA1000ES/DB790

Ver. 1.4

VIDEO **VIDEO-AU** **VOL**

Ref. No.	Part No.	Description	Remark
J305	1-794-978-11	JACK, PIN 3P (VIDEO VIDEO 2 OUT, DVD IN, TV/SAT IN)	
< RESISTOR >			
R301	1-247-804-11	CARBON 75 5% 1/4W	
R302	1-247-804-11	CARBON 75 5% 1/4W	
R303	1-247-804-11	CARBON 75 5% 1/4W	
R304	1-247-804-11	CARBON 75 5% 1/4W	
R305	1-247-804-11	CARBON 75 5% 1/4W	
R306	1-247-804-11	CARBON 75 5% 1/4W	
R307	1-247-804-11	CARBON 75 5% 1/4W	

VIDEO-AU BOARD

< CAPACITOR >

C201	1-127-868-11	CERAMIC 2200PF 10% 50V	
C211	1-127-880-11	CERAMIC 0.022uF 10% 50V	
C212	1-127-880-11	CERAMIC 0.022uF 10% 50V	
C213	1-128-809-11	CERAMIC 100PF 5% 50V	
C214	1-127-876-11	CERAMIC 0.01uF 10% 50V	
C215	1-127-868-11	CERAMIC 2200PF 10% 50V	

< CONNECTOR >

CN201	1-766-719-41	CONNECTOR, BOARD TO BOARD 10P	
* CN202	1-564-719-11	PIN, CONNECTOR (SMALL TYPE) 3P	

< IC >

IC201	8-759-582-65	IC TC9273N-014	
-------	--------------	----------------	--

< JACK >

J201	1-774-411-11	JACK, PIN 6P (VIDEO AUDIO VIDEO 2 OUT, DVD IN, TV/SAT IN)	
J202	1-774-411-11	JACK, PIN 6P (VIDEO AUDIO VIDEO 1 IN, VIDEO 1 OUT, VIDEO 2 IN)	

< RESISTOR >

R201	1-249-417-11	CARBON 1K 5% 1/4W	
R202	1-249-417-11	CARBON 1K 5% 1/4W	
R203	1-249-421-11	CARBON 2.2K 5% 1/4W	
R204	1-249-417-11	CARBON 1K 5% 1/4W	
R205	1-249-421-11	CARBON 2.2K 5% 1/4W	
R206	1-249-417-11	CARBON 1K 5% 1/4W	
△R207	1-249-399-11	CARBON 33 5% 1/4W	F
△R208	1-249-399-11	CARBON 33 5% 1/4W	F
R211	1-249-417-11	CARBON 1K 5% 1/4W	
R251	1-249-417-11	CARBON 1K 5% 1/4W	
R252	1-249-417-11	CARBON 1K 5% 1/4W	
R253	1-249-421-11	CARBON 2.2K 5% 1/4W	
R254	1-249-417-11	CARBON 1K 5% 1/4W	
R255	1-249-421-11	CARBON 2.2K 5% 1/4W	
R256	1-249-417-11	CARBON 1K 5% 1/4W	

Ref. No.	Part No.	Description	Remark
		VOL BOARD *****	
< CONNECTOR >			
CN1060	1-779-978-11	PIN, CONNECTOR 3P	
< ROTARY ENCODER >			
RV1060	1-418-725-41	ENCODER, ROTARY (12 TYPE) (MASTER VOLUME)	

MISCELLANEOUS

△53	1-696-847-21	CORD, POWER (AUS)	
△53	1-769-079-22	CORD, POWER (KR)	
△53	1-769-743-11	CORD, POWER (CND)	
△53	1-777-071-23	CORD, POWER (AEP, UK, SP, MY)	
△53	1-782-464-22	CORD, POWER (CH)	
△53	1-783-820-11	CORD, POWER (US)	
△53	1-827-597-41	CORD, POWER (TW)	
108	1-769-938-11	WIRE (FLAT TYPE) (11 CORE) (DA1000ES/DB790: SP, MY, TW, KR, AUS, CH)	
108	1-773-002-11	WIRE (FLAT TYPE) (15 CORE) (AEP, UK)	
354	1-773-270-11	WIRE (FLAT TYPE) (27 CORE)	
F1	1-532-504-51	FUSE (4A/250V) (DB790: AEP, UK, SP, MY, KR, AUS, CH)	
F1	1-533-312-11	FUSE, GLASS CYLINDRICAL (DIA.5) (10A/125V) (DA1000ES/DB790: TW)	
F2	1-532-464-51	FUSE (T2.5AL/250V) (DB790: SP, MY)	
F2	1-533-312-11	FUSE, GLASS CYLINDRICAL (DIA.5) (10A/125V) (DA1000ES)	
F903	1-532-504-51	FUSE (4A/250V) (DB790)	
F903	1-576-108-11	FUSE (4A/125V) (DA1000ES)	
F904	1-532-504-51	FUSE (4A/250V) (DB790)	
F904	1-576-108-11	FUSE (4A/125V) (DA1000ES)	
IC952	8-759-231-53	IC M5F7805L	
IC953	8-759-231-53	IC M5F7805L	
IC954	8-759-245-87	IC M5F7915L	
IC955	8-759-231-59	IC M5F7815L	
Q402	6-702-390-01	IC MN2488-OPY-MK	
Q403	6-702-391-01	IC MP1620-OPY-MK	
Q452	6-702-390-01	IC MN2488-OPY-MK	
Q453	6-702-391-01	IC MP1620-OPY-MK	
Q502	6-702-390-01	IC MN2488-OPY-MK	
Q503	6-702-391-01	IC MP1620-OPY-MK	
Q552	6-702-390-01	IC MN2488-OPY-MK	
Q553	6-702-391-01	IC MP1620-OPY-MK	
Q602	6-702-390-01	IC MN2488-OPY-MK	
Q603	6-702-391-01	IC MP1620-OPY-MK	
Q652	6-702-390-01	IC MN2488-OPY-MK	
Q653	6-702-391-01	IC MP1620-OPY-MK	
Q702	6-702-390-01	IC MN2488-OPY-MK	
Q703	6-702-391-01	IC MP1620-OPY-MK	
△T901	1-439-800-11	TRANSFORMER, POWER (DB790: CH)	
△T901	1-439-801-11	TRANSFORMER, POWER (DB790: TW)	
△T901	1-439-802-11	TRANSFORMER, POWER (DA1000ES)	
△T901	1-439-803-11	TRANSFORMER, POWER (DB790: AEP, UK, SP, MY, KR, AUS)	

The components identified by mark △ or dotted line with mark △ are critical for safety. Replace only with part number specified.	Les composants identifiés par une marque △ sont critiques pour la sécurité. Ne les remplacer que par une pièce portant le numéro spécifié.	以阴影和 △标志来识别的零部件，在安全方面具有关键性。因此只能以规定号码的零部件来更换。
--	--	--

Ref. No.	Part No.	Description	Remark	Ref. No.	Part No.	Description	Remark
TU301	1-693-577-21	TUNER (DA1000ES)		4-247-244-71	MANUAL (PP412), INSTRUCTION (PORTUGUESE, DANISH, FINNISH, RUSSIAN) (DB790: AEP)		
TU301	1-693-578-21	TUNER (DB790: AEP, UK)		4-247-244-81	MANUAL (PP412), INSTRUCTION (GREEK, HUNGARIAN, CZECH, TURKISH, SLOVAKIAN) (DB790: AEP)		
TU301	1-693-580-23	TUNER (DB790: SP, MY, TW, KR, AUS, CH)		4-250-659-11	MANUAL, INSTRUCTION (CHINESE) (DB790: CH)		

ACCESSORIES							

	1-477-793-11	COMMANDER, STANDARD (RM-PP412) (DB790)					
	1-477-843-11	COMMANDER, STANDARD (RM-LG112) (DA1000ES)					
	1-501-374-72	ANTENNA, LOOP (AM)					
	1-501-807-12	ANTENNA (FM)					
△	1-770-019-11	ADAPTOR, CONVERSION PLUG 3P (DB790: UK, AUS)					
	1-793-184-21	CONNECTOR (F TYPE ADAPTOR) (FM) (DA1000ES)					
	3-071-119-01	COVER, BATTERY (for REMOTE COMMANDER)					
	4-246-802-11	MANUAL, INSTRUCTION (ENGLISH) (DA1000ES/DB790: AEP, UK, AUS, SP, MY, TW)					
	4-246-802-21	MANUAL, INSTRUCTION (FRENCH) (DA1000ES: CND/DB790: AEP, SP, MY)					
	4-246-802-31	MANUAL, INSTRUCTION (SPANISH) (DB790: AEP, SP, MY)					
	4-246-802-41	MANUAL, INSTRUCTION (GERMAN, DUTCH, ITALIAN) (DB790: AEP)					
	4-246-802-51	MANUAL, INSTRUCTION (SWEDISH, POLISH) (DB790: AEP)					
	4-246-802-61	MANUAL, INSTRUCTION (TRADITIONAL CHINESE) (DB790: SP, MY, TW)					
	4-246-802-71	MANUAL, INSTRUCTION (KOREAN) (DB790: KR)					
	4-247-240-11	MANUAL (1-2), INSTRUCTION (PORTUGUESE) (DB790: AEP)					
	4-247-240-21	MANUAL (1-2), INSTRUCTION (DANISH, FINNISH) (DB790: AEP)					
	4-247-240-31	MANUAL (1-2), INSTRUCTION (RUSSIAN) (DB790: AEP)					
	4-247-240-41	MANUAL (1-2), INSTRUCTION (GREEK) (DB790: AEP)					
	4-247-240-51	MANUAL (1-2), INSTRUCTION (HUNGARIAN, CZECH) (DB790: AEP)					
	4-247-240-61	MANUAL (1-2), INSTRUCTION (SLOVAKIAN) (DB790: AEP)					
	4-247-243-11	MANUAL (LG112), INSTRUCTION (ENGLISH) (DA1000ES)					
	4-247-243-21	MANUAL (LG112), INSTRUCTION (FRENCH) (DA1000ES: CND)					
	4-247-244-11	MANUAL (PP412), INSTRUCTION (ENGLISH) (DB790: AEP, UK, AUS, SP, MY)					
	4-247-244-21	MANUAL (PP412), INSTRUCTION (FRENCH) (DB790: AEP, SP, MY)					
	4-247-244-31	MANUAL (PP412), INSTRUCTION (SPANISH) (DB790: AEP, SP, MY)					
	4-247-244-41	MANUAL (PP412), INSTRUCTION (GERMAN, DUTCH, SWEDISH, ITALIAN, POLISH) (DB790: AEP)					
	4-247-244-51	MANUAL (PP412), INSTRUCTION (TRADITIONAL CHINESE) (DB790: SP, MY, TW)					
	4-247-244-61	MANUAL (PP412), INSTRUCTION (KOREAN) (DB790: KR)					

The components identified by mark △ or dotted line with mark △ are critical for safety. Replace only with part number specified.

Les composants identifiés par une marque △ sont critiques pour la sécurité. Ne les remplacer que par une pièce portant le numéro spécifié.

以阴影和 △ 标志来识别的零部件，在安全方面具有关键性。因此只能以规定号码的零部件来更换。

