

STR-DE495/DE595

SERVICE MANUAL

Ver 1.1 2003.04

US Model
Canadian Model
STR-DE595
AEP Model
UK Model
E Model
Australian Model
Korean Model
STR-DE495/DE595



Photo: STR-DE595

Manufactured under license from Dolby Laboratories. "Dolby", "Pro Logic" and the double-D symbol are trademarks of Dolby Laboratories. "DTS" and "DTS Digital Surround" are registered trademarks of Digital Theater Systems, Inc.

SPECIFICATIONS

AUDIO POWER SPECIFICATIONS

POWER OUTPUT AND TOTAL HARMONIC DISTORTION:

With 8 ohm loads, both channels driven, from 40 – 20,000 Hz; rated 90 watts per channel minimum RMS power, with no more than 0.09 % total harmonic distortion from 250 milliwatts to rated output (STR-DE595 area code US only).

Amplifier section

POWER OUTPUT

Models of area code US, CND
Rated Power Output at Stereo Mode
(8 ohms 40 Hz – 20 kHz, THD 0.09 %)
STR-DE595: 90 W + 90 W
STR-DE495: 70 W + 70 W

Reference Power Output
(8 ohms 40 Hz – 20 kHz, THD 0.09 %)
STR-DE595: FRONT¹⁾: 90 W/ch
CENTER¹⁾: 90 W
SURR¹⁾: 90 W/ch
STR-DE495: FRONT¹⁾: 70 W/ch
CENTER¹⁾: 70 W
SURR¹⁾: 70 W/ch

(8 ohms 1 kHz, THD 0.7 %)
STR-DE595: FRONT¹⁾: 100 W/ch
CENTER¹⁾: 100 W
SURR¹⁾: 100 W/ch
STR-DE495: FRONT¹⁾: 80 W/ch
CENTER¹⁾: 80 W
SURR¹⁾: 80 W/ch

Models of area code AEP, UK
Rated Power Output at Stereo Mode
(8 ohms 1 kHz, THD 0.7 %)
STR-DE595: 100 W + 100 W²⁾
STR-DE495: 80 W + 80 W²⁾

Reference Power Output²⁾
(8 ohms 1 kHz, THD 0.7 %)
STR-DE595: FRONT¹⁾: 100 W/ch
CENTER¹⁾: 100 W
SURR¹⁾: 100 W/ch
STR-DE495: FRONT¹⁾: 80 W/ch
CENTER¹⁾: 80 W
SURR¹⁾: 80 W/ch

Models of area code SP
Rated Power Output at Stereo Mode
(8 ohms 1 kHz, THD 0.7 %)
STR-DE595: 90 W + 90 W²⁾
STR-DE495: 70 W + 70 W²⁾

Reference Power Output²⁾
(8 ohms 1 kHz, THD 10 %)
STR-DE595: FRONT¹⁾: 110 W/ch
CENTER¹⁾: 110 W
SURR¹⁾: 110 W/ch
STR-DE495: FRONT¹⁾: 90 W/ch
CENTER¹⁾: 90 W
SURR¹⁾: 90 W/ch

Models of area code KR
Rated Power Output at Stereo Mode
(8 ohms 1 kHz, THD 0.7 %)
STR-DE595: 100 W + 100 W²⁾
90 W + 90 W³⁾
STR-DE495: 80 W + 80 W²⁾
70 W + 70 W³⁾

Reference Power Output²⁾
(8 ohms 1 kHz, THD 10 %)
STR-DE595: FRONT¹⁾: 120 W/ch
CENTER¹⁾: 120 W
SURR¹⁾: 120 W/ch
STR-DE495: FRONT¹⁾: 100 W/ch
CENTER¹⁾: 100 W
SURR¹⁾: 100 W/ch

Models of other area code
Rated Power Output at Stereo Mode
(8 ohms 1 kHz, THD 0.7 %)
STR-DE595: 100 W + 100 W²⁾
80 W + 80 W²⁾
Reference Power Output²⁾
(8 ohms 1 kHz, THD 10 %)
STR-DE595: FRONT¹⁾: 120 W/ch
CENTER¹⁾: 120 W
SURR¹⁾: 120 W/ch
STR-DE495: FRONT¹⁾: 100 W/ch
CENTER¹⁾: 100 W
SURR¹⁾: 100 W/ch

– Continued on next page –

FM STEREO/FM-AM RECEIVER

9-877-028-02
2003D0400-1
© 2003. 04

Sony Corporation
Home Audio Company
Published by Sony Engineering Corporation

SONY®

STR-DE495/DE595

Ver 1.1

1) Depending on the sound field settings and the source, there may be no sound output.

2) Measured under the following conditions:

Area code	Power requirements
E2, AUS	240 V AC, 50 Hz
SP, MY, AEP, UK, AR, KR	230 V AC, 50 Hz
TW	110 V AC, 60 Hz

Frequency response

MULTI CH IN (STR-DE595 only), CD (STR-DE495 only), MD/TAPE, DVD, VIDEO 1, 2	10 Hz – 50 kHz +0.5/-2 dB (with sound field and tone bypassed)
CD/SACD (STR-DE595 only)	10 Hz – 70 kHz +0.5/-2 dB (with sound field and tone bypassed)

Inputs (Analog)

MULTI CH IN (STR-DE595 only), CD/SACD (STR-DE595 only), CD (STR-DE495 only), MD/TAPE, DVD, VIDEO 1, 2	Sensitivity: 500 mV Impedance: 50 kilohms S/N ³⁾ : 96 dB (A, 500 mV ⁴⁾)
---	---

3) INPUT SHORT (with sound field and tone bypassed).

4) Weighted network, input level.

Inputs (Digital)

DVD (Coaxial)	Sensitivity: – Impedance: 75 ohms S/N: 100 dB (A, 20 kHz LPF)
CD/SACD (Optical) (STR-DE595 only), VIDEO 2 (Optical)	Sensitivity: – Impedance: – S/N: 100 dB (A, 20 kHz LPF)

Outputs

MD/TAPE (OUT), VIDEO1 (AUDIO OUT)	Voltage: 500 mV Impedance: 10 kilohms
SUB WOOFER	Voltage: 2 V Impedance: 1 kilohms

Tone

Gain levels: ±6 dB, 1 dB step

FM tuner section

Tuning range	87.5 - 108.0 MHz
Antenna terminals	75 ohms, unbalanced
Intermediate Frequency	10.7 MHz
Sensitivity	
Mono:	18.3 dBf, 2.2 µV/75 ohms
Stereo:	38.3 dBf, 22.5 µV/75 ohms
Usable sensitivity	11.2 dBf, 1 µV/75 ohms
S/N	
Mono:	76 dB
Stereo:	70 dB
Harmonic distortion at 1 kHz	
Mono:	0.3%
Stereo:	0.5%
Separation	45 dB at 1 kHz
Frequency response	30 Hz – 15 kHz, +0.5/-2 dB
Selectivity	60 dB at 400 kHz

AM tuner section

Tuning range

Models of area code US, CND
With 10-kHz tuning scale: 530 – 1710 kHz⁵⁾
With 9-kHz tuning scale: 531 – 1710 kHz⁵⁾

Models of area code E2
With 10-kHz tuning scale: 530 – 1610 kHz⁵⁾
With 9-kHz tuning scale: 531 – 1602 kHz⁵⁾

Models of area code AUS, SP, AEP, UK, TW, KR
With 9-kHz tuning scale: 531 – 1602 kHz

Models of area code MX, AR
With 10-kHz tuning scale: 530 – 1610 kHz

Antenna	Loop antenna
Intermediate Frequency	450 kHz
Usable sensitivity	50 dB/m (at 1,000 kHz or 999 kHz)
S/N	54 dB (at 50 mV/m)
Harmonic distortion	0.5 % (50 mV/m, 400 Hz)
Selectivity	
At 9 kHz:	35 dB
At 10 kHz:	40 dB

5) You can change the AM tuning scale to 9 kHz or 10 kHz. After tuning in any AM station, turn off the receiver. Hold down PRESET TUNING + and press I/⏪. All preset stations will be erased when you change the tuning scale. To reset the scale to 10 kHz (or 9 kHz), repeat the procedure.

Video section

Inputs

Video: 1 V_{p-p}, 75 ohms

Component Video (STR-DE595 only, except for models of area code AEP, UK):

Y: 1 V_{p-p}, 75 ohms
P_B/B-Y: 0.7 V_{p-p}, 75 ohms
Pr/R-Y: 0.7 V_{p-p}, 75 ohms

Outputs

Video: 1 V_{p-p}, 75 ohms

Component Video (STR-DE595 only, except for models of area code AEP, UK):

Y: 1 V_{p-p}, 75 ohms
P_B/B-Y: 0.7 V_{p-p}, 75 ohms
Pr/R-Y: 0.7 V_{p-p}, 75 ohms

General

Power requirements

Area code	Power requirements
US, CND, MX	120 V AC, 60 Hz
AEP, UK	230 V AC, 50/60 Hz
SP, MY, KR, AR	220 – 230 V AC, 50/60 Hz
E2	120/220/240 V AC, 50/60 Hz
TW	110 V AC, 50/60 Hz
AUS	240 V AC, 50Hz

Power consumption

Area code	Power consumption
US, MX	STR-DE595: 210 W
CND	STR-DE595: 310 VA
AEP, UK, TW, KR	STR-DE595: 210 W STR-DE495: 180 W
SP, MY	STR-DE595: 180 W
AUS, E2, AR	STR-DE595: 210 W

Power consumption (during standby mode)

0.3 W

Dimensions
430 × 145 × 298 mm
(16 7/8 × 5 6/8 × 11 6/8 in.)
including projecting parts
and controls

Mass (Approx.)
STR-DE595: 7.5 kg (16 lb 9 oz)
STR-DE495: 7.2 kg (15 lb 14 oz)

Supplied accessories

FM wire antenna (1)
AM loop antenna (1)
Remote commander RM-U306A (1)
R6 (size-AA) batteries (2)

Design and specifications are subject to change without notice.

• Abbreviation

CND : Canadian model
AUS : Australian model
MX : Mexican model
SP : Singapore model
E2 : AC 120 V area in E model
AR : Argentine model
KR : Korean model
TW : Taiwan model

SAFETY CHECK-OUT

After correcting the original service problem, perform the following safety check before releasing the set to the customer:
Check the antenna terminals, metal trim, "metallized" knobs, screws, and all other exposed metal parts for AC leakage.
Check leakage as described below.

LEAKAGE TEST

The AC leakage from any exposed metal part to earth ground and from all exposed metal parts to any exposed metal part having a return to chassis, must not exceed 0.5 mA (500 microamperes.). Leakage current can be measured by any one of three methods.

1. A commercial leakage tester, such as the Simpson 229 or RCA WT-540A. Follow the manufacturers' instructions to use these instruments.
2. A battery-operated AC milliammeter. The Data Precision 245 digital multimeter is suitable for this job.
3. Measuring the voltage drop across a resistor by means of a VOM or battery-operated AC voltmeter. The "limit" indication is 0.75 V, so analog meters must have an accurate low-voltage scale. The Simpson 250 and Sanwa SH-63Trd are examples of a passive VOM that is suitable. Nearly all battery operated digital multimeters that have a 2 V AC range are suitable. (See Fig. A)

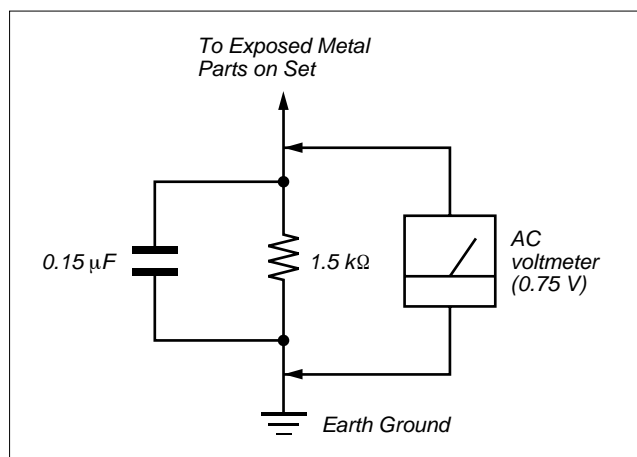

MODEL IDENTIFICATION

— BACK PANEL —

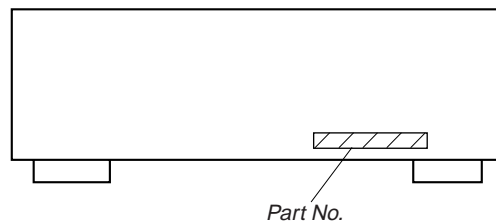

MODEL	PART No.
DE595: Korean	4-244-149-0□
DE595: Taiwan	4-244-149-1□
DE595: Argentine	4-244-149-4□
DE595: US	4-246-023-0□
DE595: Canadian	4-246-023-1□
DE595: Australian	4-246-023-2□
DE595: Singapore, Malaysia	4-246-023-3□
DE595: E2	4-246-023-4□
DE595: Mexican	4-246-023-5□
DE595: AEP	4-246-023-6□
DE595: UK	4-246-023-7□
DE495: AEP	4-246-034-1□
DE595: UK	4-246-034-2□
DE495: Singapore, Malaysia	4-246-034-3□
DE495: Taiwan	4-246-034-4□
DE495: Korean	4-246-034-5□
DE495: Australian	4-246-034-7□

SAFETY-RELATED COMPONENT WARNING!!

COMPONENTS IDENTIFIED BY MARK \triangle OR DOTTED LINE WITH MARK \triangle ON THE SCHEMATIC DIAGRAMS AND IN THE PARTS LIST ARE CRITICAL TO SAFE OPERATION. REPLACE THESE COMPONENTS WITH SONY PARTS WHOSE PART NUMBERS APPEAR AS SHOWN IN THIS MANUAL OR IN SUPPLEMENTS PUBLISHED BY SONY.

ATTENTION AU COMPOSANT AYANT RAPPORT À LA SÉCURITÉ!!

LES COMPOSANTS IDENTIFIÉS PAR UNE MARQUE \triangle SUR LES DIAGRAMMES SCHÉMATIQUES ET LA LISTE DES PIÈCES SONT CRITIQUES POUR LA SÉCURITÉ DE FONCTIONNEMENT. NE REMPLACER CES COMPOSANTS QUE PAR DES PIÈCES SONY DONT LES NUMÉROS SONT DONNÉS DANS CE MANUEL OU DANS LES SUPPLÉMENTS PUBLIÉS PAR SONY.

TABLE OF CONTENTS

1. GENERAL

Main unit	5
Remote button description	6

2. DISASSEMBLY

2-1. Case	7
2-2. Front Panel Section	8
2-3. Back Panel	8
2-4. Digital Board	9
2-5. Standby Board	9
2-6. Main Board	10

3. TEST MODE 11

4. DIAGRAMS

4-1. IC Pin Descriptions	12
4-2. Circuit Boards Location	15
4-3. Block Diagram – Tuner/Audio Section –	16
4-4. Block Diagram – Digital Section –	17
4-5. Block Diagram – Video/Display Section –	18
4-6. Block Diagram – Power Section –	19
4-7. Printed Wiring Boards – Main Section –	21
4-8. Schematic Diagram – Main Section (1/2) –	22
4-9. Schematic Diagram – Main Section (2/2) –	23
4-10. Printed Wiring Board – Digital Section (1/2) –	24
4-11. Printed Wiring Board – Digital Section (2/2) –	25
4-12. Schematic Diagram – Digital Section (1/2) –	26
4-13. Schematic Diagram – Digital Section (2/2) –	27
4-14. Printed Wiring Board – Video Section –	28
4-15. Schematic Diagram – Video Section –	29
4-16. Printed Wiring Boards – Display Section –	30
4-17. Schematic Diagram – Display Section –	31
4-18. Printed Wiring Boards – Power Section –	32
4-19. Schematic Diagram – Power Section –	33
4-20. IC Block Diagrams	34

5. EXPLODED VIEWS

5-1. Case Section	36
5-2. Front Panel Section	37
5-3. Chassis Section-1	38
5-4. Chassis Section-2	39

6. ELECTRICAL PARTS LIST 40

SECTION 1 GENERAL

This section is extracted from instruction manual.

List of Button Locations and Reference Pages

How to use this page

Use this page to find the location of buttons that are mentioned in the text.

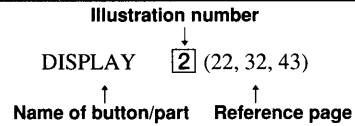

Main unit

ALPHABETICAL ORDER

A - L

- A.F.D. (button/indicator) **21** (23-25)
- CD (STR-DE495 only) **9** (21)
- CD/SACD (STR-DE595 only) **9** (21)
- DIMMER **3** (22)
- DISPLAY **2** (22, 32, 43)
- Display **11** (22)
- DVD **7** (21)
- ENTER **19** (34, 36)
- FM MODE **26** (30)
- INPUT MODE **13** (21)
- IR (receptor) **4** (37, 43)

M - O

- MAIN MENU **14** (16, 27, 28, 34, 35, 47)
- MASTER VOLUME **12** (20, 21, 41)
- MD/TAPE **8** (21)
- MEMORY **27** (29, 31)
- MENU +/- **16** (16, 27, 28, 34, 35, 47)
- MENU </> **17** (16, 27, 28, 34, 35, 47)
- MOVIE (button/indicator) **20** (24, 42)
- MULTI CHANNEL DECODING (indicator) (STR-DE595 only) **23** (21)
- MULTI CH IN (STR-DE595 only) **18** (21)
- MUSIC (button/indicator) **19** (24, 25, 42)

P - Z

- PHONES (jack) **28** (22, 26, 42)
- PRESET TUNING +/- **24** (31, 46)
- SPEAKERS (OFF/A/B/A+B) (STR-DE595 only) **29** (13, 22, 41)
- TUNER FM/AM **10** (21, 30, 31, 34)
- TUNING +/- **25** (30)
- VIDEO 1 **5** (21)
- VIDEO 2 **6** (21)

NUMBERS AND SYMBOLS

- 2CH (button/indicator) **22** (23, 25, 28)
- I/⏻ (power) **1** (15, 20, 28, 29, 36, 46)

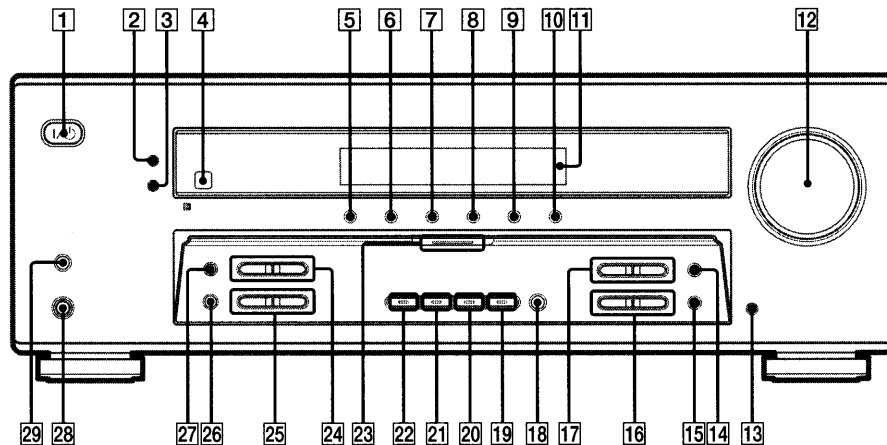

List of Button Locations and Reference Pages

5GB

Operations Using the Remote RM-U306A

You can use the remote RM-U306A to operate the components in your system.

Before you use your remote

Inserting batteries into the remote

Insert R6 (size-AA) batteries with the + and – properly oriented in the battery compartment. When using the remote, point it at the remote sensor on the receiver.

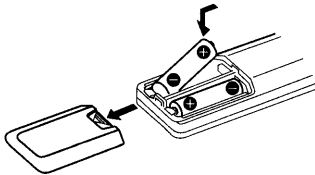

Tip

Under normal conditions, the batteries should last for about 6 months. When the remote no longer operates the receiver, replace all batteries with new ones.

Notes

- Do not leave the remote in an extremely hot or humid place.
- Do not use a new battery with an old one.
- Do not expose the remote sensor to direct sunlight or lighting apparatuses. Doing so may cause a malfunction.
- If you don't use the remote for an extended period of time, remove the batteries to avoid possible damage from battery leakage and corrosion.

Remote button description

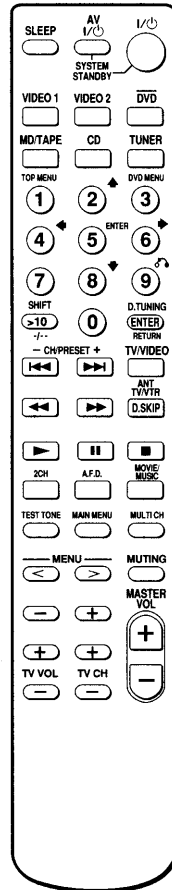

Operations Using the Remote RM-U306A

The tables below show the settings of each button.

Remote Button	Operations	Function
SLEEP	Receiver	Activates the sleep function and the duration which the receiver turns off automatically.
I/⏻	Receiver	Turns the receiver on or off.

continued

SECTION 2 DISASSEMBLY

Note : This set can be disassemble according to the following sequence.

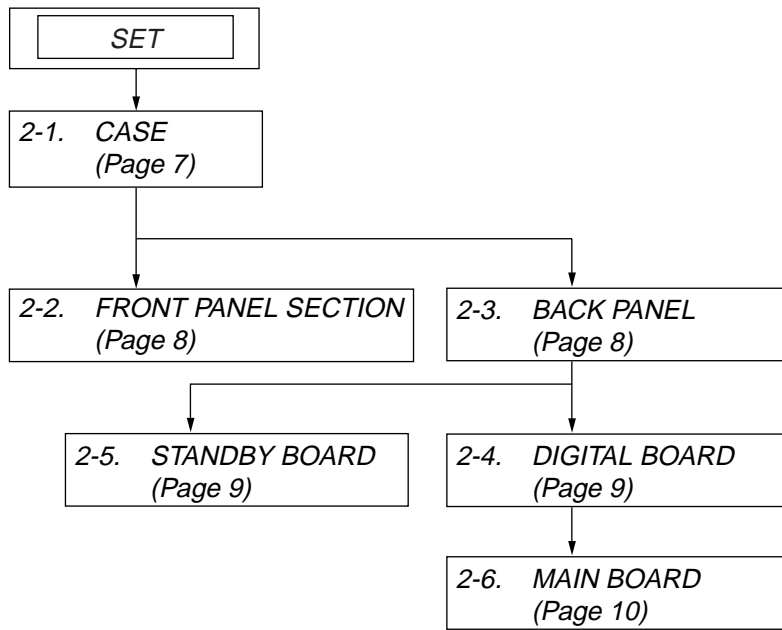

Note : Follow the disassembly procedure in the numerical order given.

2-1. CASE

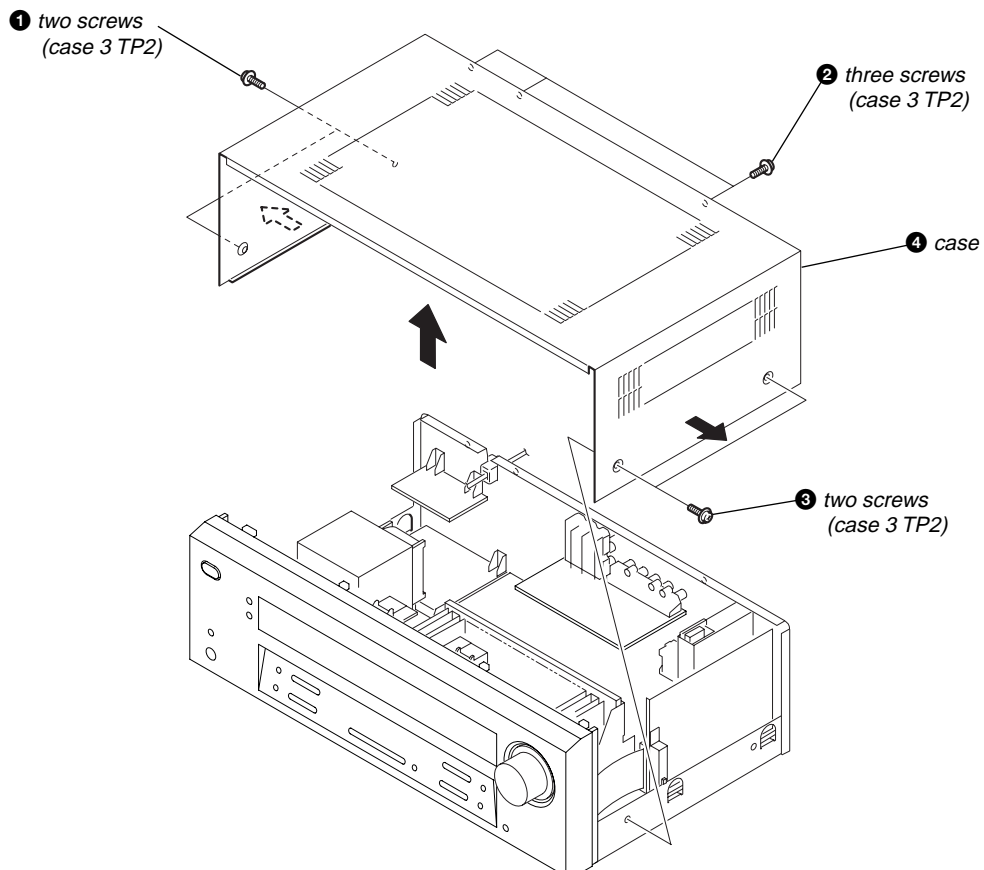

2-2. FRONT PANEL SECTION

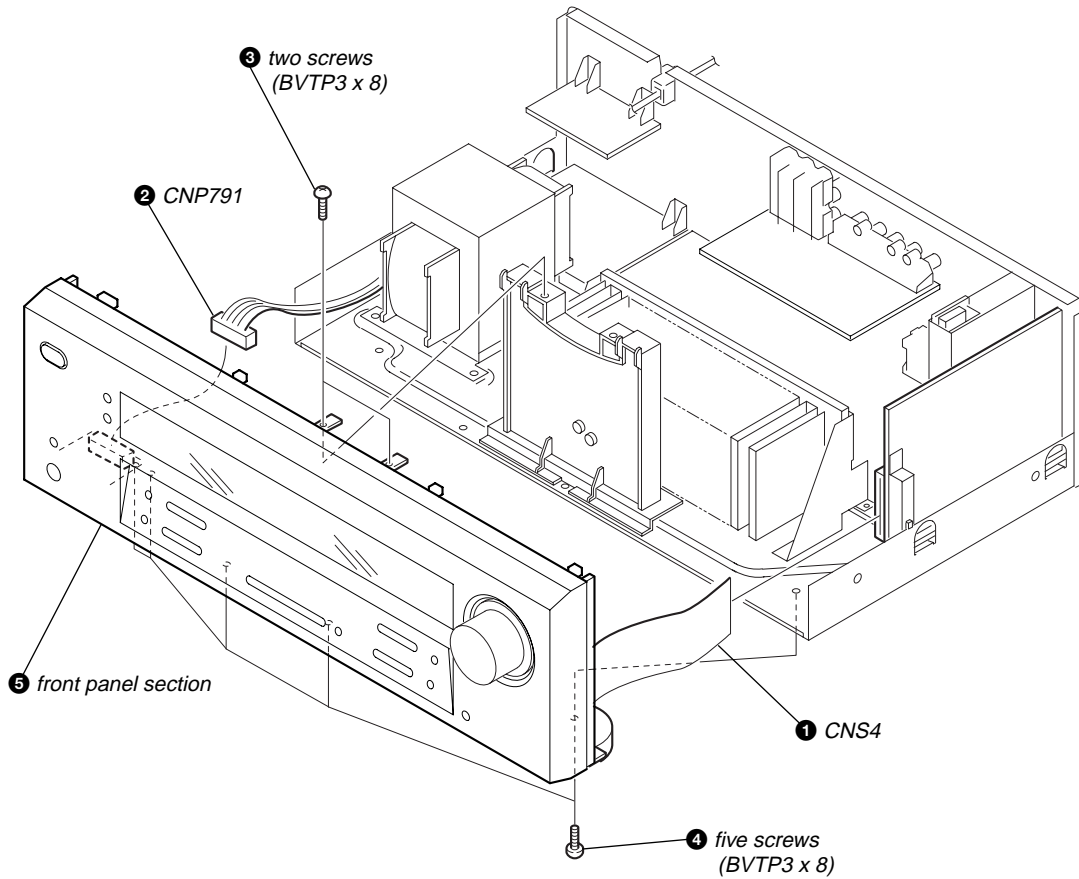

2-3. BACK PANEL

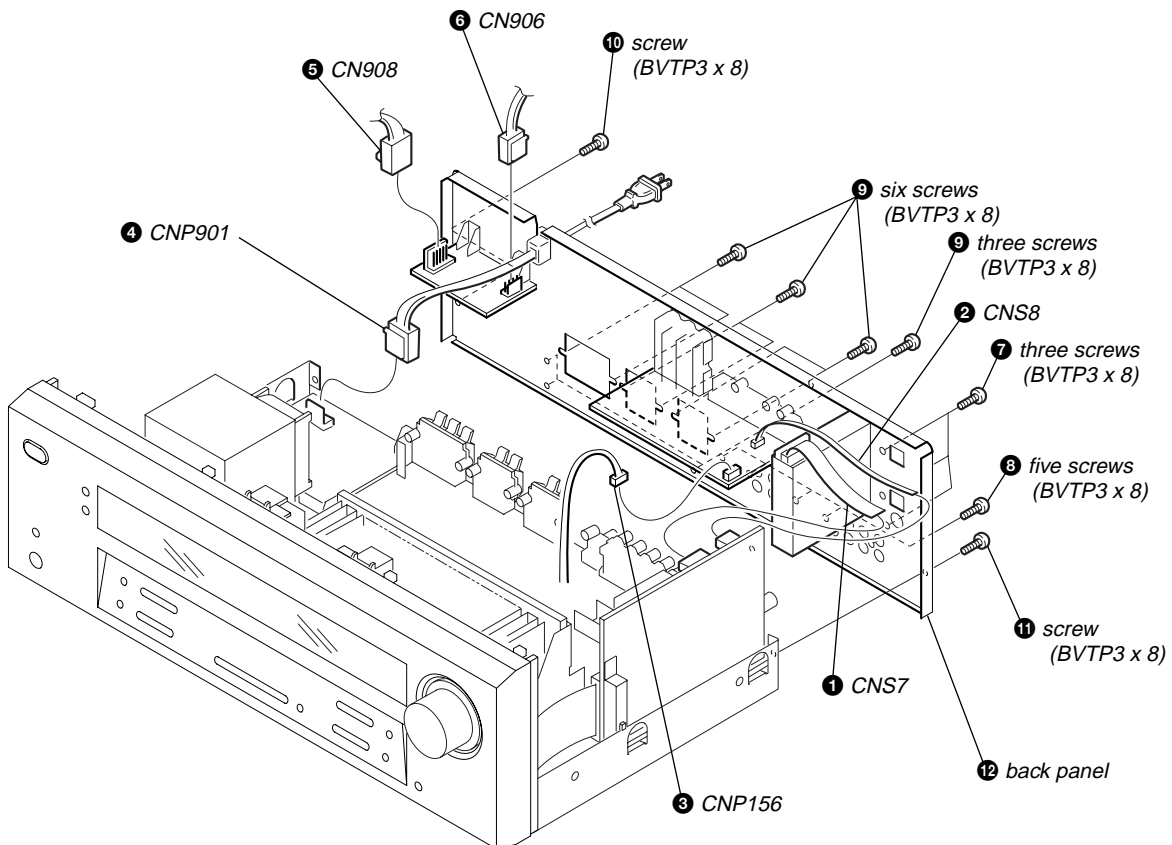

2-4. DIGITAL BOARD

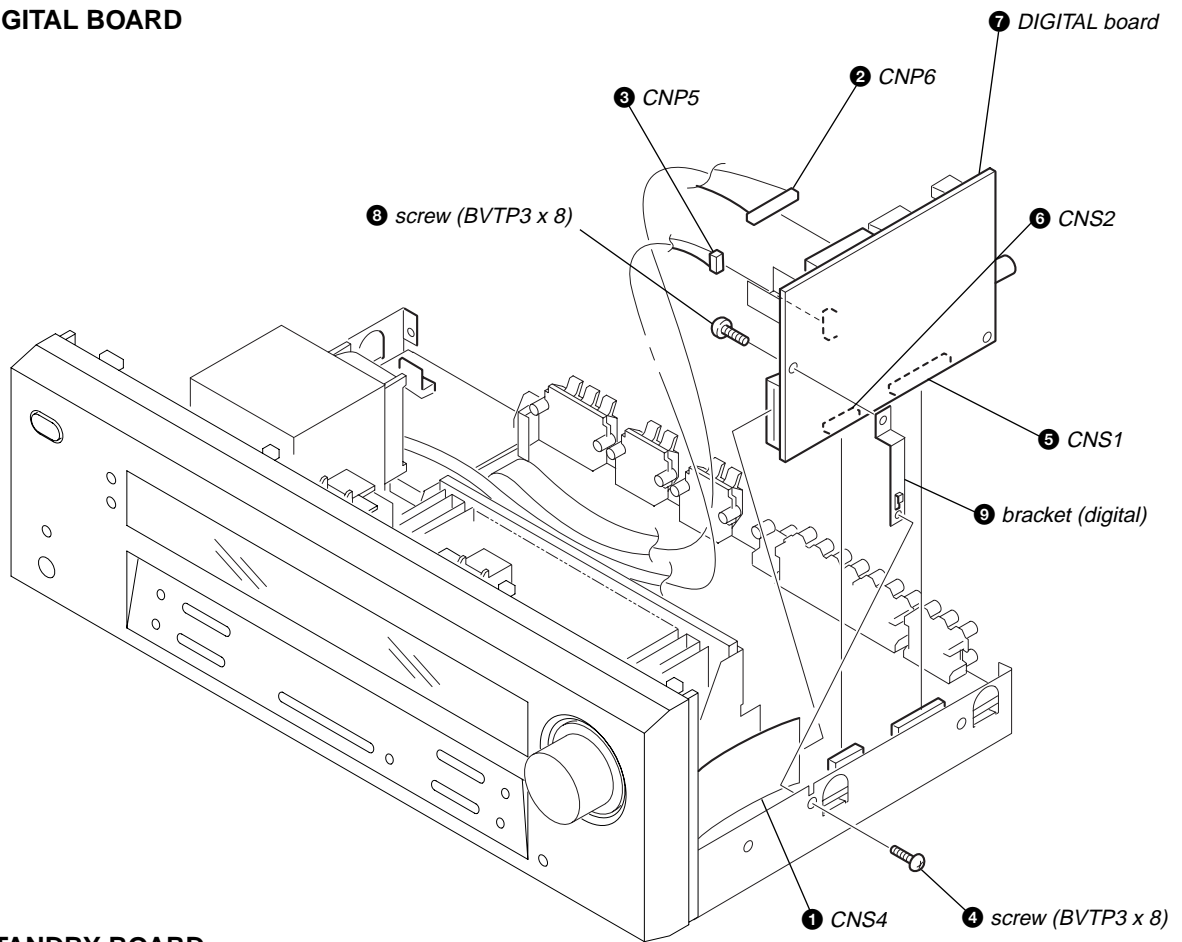

2-5. STANDBY BOARD

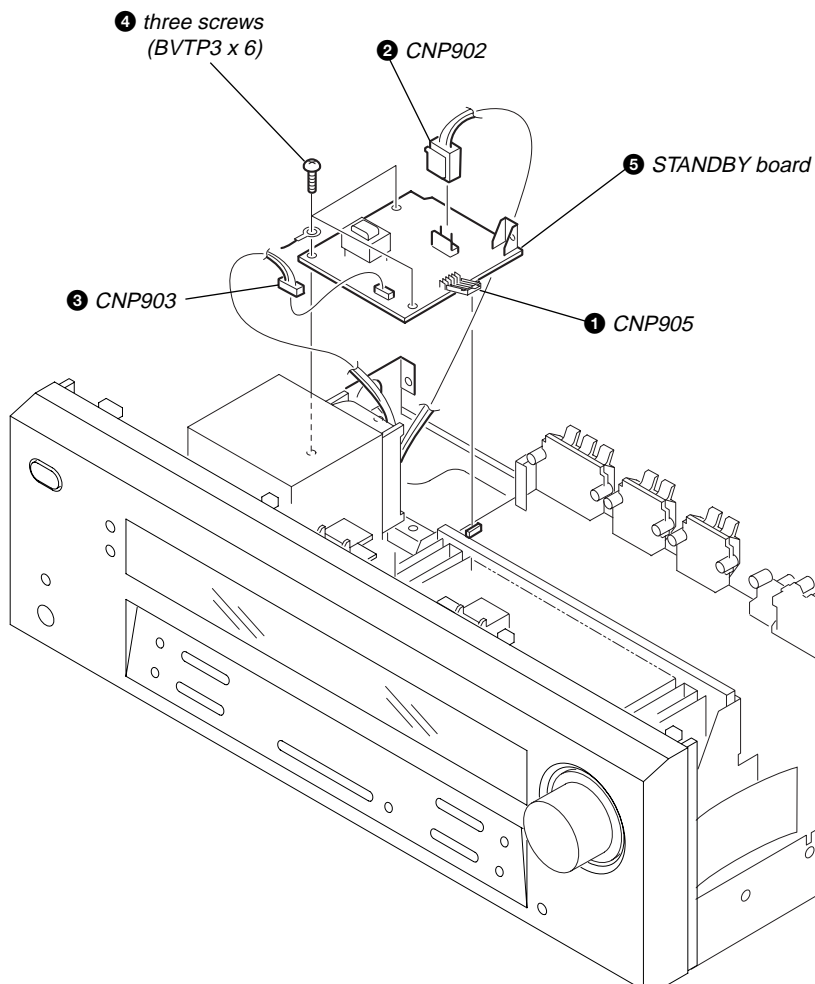

2-6. MAIN BOARD

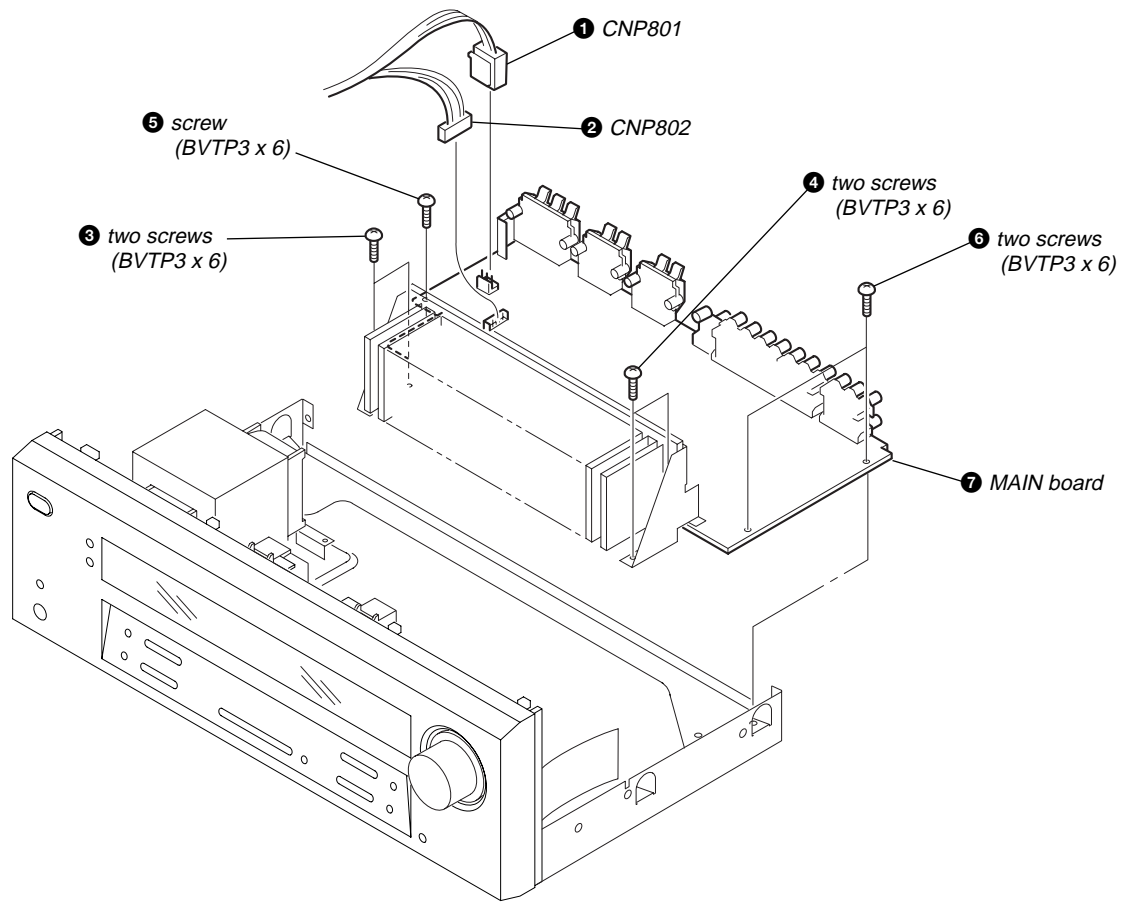

SECTION 3 TEST MODE

FACTORY PRESET MODE

- * All preset contents are reset to the default setting.
- * Procedure:
While depressing the **[FM MODE]** and the **[PRESET TUNING -]** buttons simultaneously, press the **[I/⏻]** button to turn on the main power.
The message “FACTORY” appears for a moment and the present contents are reset to the default values.

AM CHANNEL STEP 9 kHz/10 kHz SELECTION MODE (US, Canadian, E model only)

- * Either the 9 kHz step or 10 kHz step can be selected for the AM channel step.
- * Procedure:
Press the **[TUNER FM/AM]** button to set AM and press the **[I/⏻]** button to turn off the main power.
While depressing the **[TUNING +]** button or the **[PRESET TUNING +]** button, press the **[I/⏻]** button to turn on the main power.
Either the message “9k STEP” or “10k STEP” appears for a moment and select the desired step.

SPEAKER SIZE SELECTION MODE

- * Either the normal speaker or micro satellite speaker can be selected.
- * Procedure:
While depressing the **[MAIN MENU]** button, press the **[I/⏻]** button to turn on the main power.
Either the message “NORM. SP.” or “MICRO SP.” appears for a moment and select the desired speaker size.

FLUORESCENT INDICATOR TUBE TEST MODE

- * All fluorescent segments are tested.
When this test is activated, all segments light on at the same time, then each segment lights on one after another.
- * Procedure:
While depressing the **[FM MODE]** and the **[MD/TAPE]** buttons simultaneously, press the **[I/⏻]** button to turn on the main power.



[2CH], **[SURROUND]**, **[MOVIE]** and **[MUSIC]** LED light on.

2. Press the **[VIDEO 1]** button, confirm display.

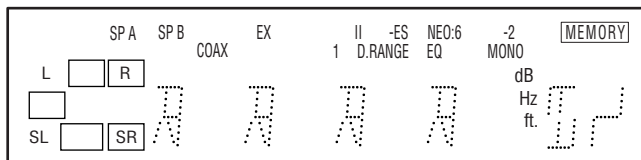

[2CH] and **[MOVIE]** LED light on.

3. Press the **[VIDEO 1]** button, confirm display.

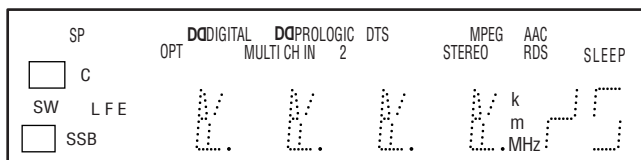

[SURROUND] and **[MUSIC]** LED light on.

4. Press the **[VIDEO 1]** button, all segments and all LEDs light on.
5. Every pressing the **[VIDEO 1]** button turns on each segment and LED one after another in the same order.
(Not only the **[VIDEO 1]** button, but also the other buttons such as **[VIDEO 2]**, **[DVD]**, **[MD/TAPE]**, **[CD]** and **[TUNER FM/AM]** can be used.)

SOUND FIELD CLEAR MODE

- * The preset sound field is cleared when this mode is activated.
Use this mode before returning the product to clients upon completion of repair.
- * Procedure:
While depressing the **[2CH]** button, press the **[I/⏻]** button to turn on the main power.
The message “SF. CLR.” appears for a moment and initialization is performed.

SOFTWARE VERSION DISPLAY MODE

- * The software version is displayed.
- * Procedure:
While depressing the **[FM MODE]** and the **[DVD]** buttons simultaneously, press the **[I/⏻]** button to turn on the main power.
The model name, destination and the software version are displayed for a moment.

KEY CHECK MODE

- * Button check
- * Procedure:
While depressing the **[MUSIC]** and the **[TUNING -]** buttons simultaneously, press the **[I/⏻]** button to turn on the main power.
Either the message “REST 26” (STR-DE495) or “REST 27” (STR-DE595) appears.
Every pressing of any button other than the **[I/⏻]** counts down the buttons. The buttons which are already counted once are not counted again. When all buttons are pressed “REST 00” appears.
When **[MASTER VOLUME]** control is rotated in clockwise direction, “VOL MIN”, “VOL 1” to “VOL 73”, “VOL MAX” appears for a moment.

AUTOBETICAL MODE (AEP, UK model only)

- * When this mode is used, the receiver scans the broadcasts that can be received by the tuner, and sets up the broadcasts.
Be sure to start scanning after connecting the antenna.
- * Procedure:
Check that the antenna is connected.
While depressing the **[MEMORY]** button, press the **[I/⏻]** button to turn on the main power.
The message “AUTO-BETICAL SELECT” appears for a moment and the receiver starts scanning.

COMMAND MODE SELECTION MODE

- * The command mode (AV1 or AV2) of the remote commander can be selected.
- * Procedure:
While depressing the **[ENTER]** button, press the **[I/⏻]** button to turn on the main power.
Either the message “C.MODE.AV 1” or “C.MODE.AV 2” appears for a moment and select the desired mode.

SECTION 4 DIAGRAMS

4-1. IC PIN DESCRIPTIONS

• IC1201 CXD9617R (DSP) (DIGITAL Board (1/2))

Pin No.	Pin Name	I/O	Pin Description
1	VSS	—	Ground
2	XRST	I	Reset signal input from SYSTEM CONTROL IC
3	EXTIN	I	Not used (Connect to ground)
4	FS2	I	Not used (Connect to ground)
5	VDDI	I	Power supply pin (+2.6 V)
6	FS1	I	Not used (Connect to ground)
7	PLOCK	O	Not used (Open)
8	VSS	—	Ground
9	MCLK1	I	Clock signal input (13.59 MHz)
10	VDDI	I	Power supply pin (+2.6 V)
11	VSS	—	Ground
12	MCLK2	O	Clock signal output (13.59 MHz)
13	MS	I	Not used (Connect to ground)
14	SCKOUT	O	Internal system clock signal output for CODEC IC
15	LRCKI1	I	Not used (Open)
16	VDDE	I	Power supply pin (+3.3 V)
17	BCKI1	I	Not used (Open)
18	SDI1	I	Audio IF data input from CODEC IC
19	LRCKO	O	Sampling clock signal output for CODEC IC
20	BCKO	O	Bit clock signal output for CODEC IC
21	VSS	—	Ground
22	KFSIO	I/O	Audio clock signal (384fs/256fs) input/output for DIR IC
23 to 25	SDO1 to SDO3	O	Digital audio serial data output for CODEC IC
26	SDO4	O	Not used (Open)
27	SPDIF	O	Not used (Open)
28	LRCKI2	I	Sampling clock signal input from DIR IC
29	BCKI2	I	Bit clock signal input from DIR IC
30	SDI2	I	Digital audio serial data input from DIR IC
31	VSS	—	Ground
32	HACN	O	Acknowledge signal output for SYSTEM CONTROL IC
33	HDIN	I	Serial data input from SYSTEM CONTROL IC
34	HCLK	I	Clock signal input from SYSTEM CONTROL IC
35	HDOUT	O	Serial data output for SYSTEM CONTROL IC
36	HCS	I	Chip select signal input from SYSTEM CONTROL IC
37	SDCLK	O	Not used (Open)
38	CLKEN	O	Not used (Open)
39	RAS	O	Not used (Open)
40	VDDI	I	Power supply pin (+2.6 V)
41	VSS	—	Ground
42	CAS	O	Not used (Open)
43	DQM/OE0	O	Not used (Open)
44	CS0	O	External memory chip select signal output for D/A converter IC (SRAM)
45	WE0	O	SRAM write enable signal output for D/A converter IC
46	VDDE	I	Power supply pin (+3.3 V)
47	WMD1	I	Not used (Fixed at H)
48	VSS	—	Ground
49	WMD0	I	Not used (Fixed at H)
50	PAGE2	O	Not used (Open)
51	VSS	—	Ground
52, 53	PAGE1, PAGE0	O	Not used (Open)
54	BOOT	I	Not used (Connect to ground)

Pin No.	Pin Name	I/O	Pin Description
55	BTACT	O	Not used (Open)
56	BST	I	Boot stop signal input from SYSTEM CONTROL IC
57	MOD1	I	Operation mode signal input (L: 386fs, H: 256fs) (Fixed at H)
58	MOD0	I	Operation mode signal input (L: single chip mode, H: use prohibited) (Fixed at L)
59	EXLOCK	I	Error detection signal input from DIR IC
60	VDDI	I	Power supply pin (+2.6 V)
61	VSS	—	Ground
62, 63	A17, A16	O	Not used (Open)
64 to 66	A15 to A13	O	External memory address signal output for D/A converter IC (SRAM)
67	GP10	O	Connect to LRCKO
68	GP9	O	Decode signal output for SYSTEM CONTROL IC
69	GP8	I	Audio signal input from DIR IC
70	VDDI	I	Power supply pin (+2.6 V)
71	VSS	—	Ground
72 to 75	D15/GP7 to D12/GP4	I/O	External memory data input/output for D/A converter IC (general port)
76	VDDE	I	Power supply pin (+3.3 V)
77 to 80	D11/GP3 to D8/GP0	I/O	External memory data input/output for D/A converter IC (general port)
81	VSS	—	Ground
82	A9	O	External memory address signal output for D/A converter IC (SRAM)
83 to 85	A12 to A10	O	External memory address signal output for D/A converter IC (SRAM)
86	TDO	O	Not used (Open)
87	TMS	I	Not used (Open)
88	XTRST	I	Not used (Open)
89	TCK	I	Not used (Open)
90	TDI	I	Not used (Open)
91	VSS	—	Ground
92 to 97	A8 to A3	O	External memory address signal output for D/A converter IC (SRAM)
98, 99	D7, D6	I/O	External memory data input/output for D/A converter IC (SRAM)
100	VDDI	I	Power supply pin (+2.6 V)
101	VSS	—	Ground
102 to 105	D5 to D2	I/O	External memory data input/output for D/A converter IC (SRAM)
106	VDDE	I	Power supply pin (+3.3 V)
107, 108	D1, D0	I/O	External memory data input/output for D/A converter IC (SRAM)
109, 110	A2, A1	O	External memory address signal output for D/A converter IC (SRAM)
111	VSS	—	Ground
112	A0	O	External memory address signal output for D/A converter IC (SRAM)
113	PM	I	PLL initialization signal input from SYSTEM CONTROL IC
114, 115	SDI3, SDI4	I	Not used (Open)
116	SYNC	I	Sync/async select signal input (L: sync, H: async) (Fixed at H)
117 to 119	VSS	—	Ground
120	VDDI	I	Power supply pin (+2.6 V)

• IC1601 MB9047BPF-G-138-BND (SYSTEM CONTROL) (DIGITAL Board (2/2))

Pin No.	Pin Name	I/O	Pin Description
1	DATAO	I	Serial data line signal input from DIR IC
2	GP9	I	GP9 signal input from DSP IC
3	BST	O	Boot stop control signal output for DSP IC
4	HCS	O	Chip select signal output for DSP IC
5	HACN	I	Acknowledge signal input from DSP IC
6	XRST	O	Reset signal output for DSP IC
7	PM	O	PLL control signal output for DSP IC
8	PD	O	Power down signal output for CODEC IC
9	SMUTE	O	Soft mute signal output for CODEC IC
10	CDT1	O	Control data output for CODEC IC
11	VSS	—	Ground
12	SCL	O	Serial data clock signal output for CODEC IC
13	CS	O	Latch signal output for CODEC IC
14	DATA	O	Serial data output for VOL/TUNER IC
15	CLK	O	Clock signal output for VOL/TUNER IC
16	LATCH- VOL IC	O	Latch signal output for VOL/TUNER IC
17	SPK B RELAY	O	Speaker B relay driver control signal output (STR-DE595 only)
18	HDOUT	I	Serial data input from DSP IC
19	HDIN	O	Serial data output for DSP IC
20	HCLK	O	Serial data clock signal output for DSP IC
21	F.MUTE	O	Function mute control signal output
22	AC MUTE	O	Power amplifier mute control signal output
23	VCC5	—	Power supply pin (+3.3 V)
24	ANA/DIG	O	Muting and error port signal output
25	HP DETECT	I	Headphone detection signal input
26	NC	—	Not used (Fixed at L)
27	FLASH2	—	Flash programming signal output 2
28	FLASH1	—	Flash programming signal output 1
29 to 32	NC	—	Not used (Fixed at L)
33	SCL	O	Clock signal output for EEPROM IC
34	SDA	I/O	Serial data input/output for EEPROM IC
35	AVCC	—	Power supply pin (+3.3 V)
36	AVRH	—	Power supply pin (+3.3 V)
37	AVSS	—	Ground
38 to 41	A/D0 to A/D3	I	Key signal input (A/D port)
42	VSS	—	Ground
43	RDS SIGNAL	I	RDS signal level input (AEP, UK model only)
44	MODEL	I	Model detection signal input (Fixed at L: US, Canadian model, H: Except for US, Canadian model)
45	VERSION	I	Destination detection signal input (Fixed at L: US, Canadian model, H: Except for US, Canadian model)
46	BLUE LED	O	LED (MULTI CHANNEL DECODING) driver signal output (STR-DE595 only)
47	NC	—	Not used (Fixed at L)
48	STOP	I	AC off detection signal input
49	MOD0	—	Selection of micon operation mode
50	MOD1	—	Not used (Connect to AVCC)
51	MOD2	—	Selection of micon operation mode
52	RDS CLOCK	I	RDS data clock signal input (AEP, UK model only)
53	RDS DATA	I	RDS data input (AEP, UK model only)
54	SIRCS	I	SIRCS signal input
55	FUSE DETECT	I	Fuse open detection signal input
56	POWER KEY	I	Power key detection signal input

Pin No.	Pin Name	I/O	Pin Description
57, 58	NC	I	Not used (Fixed at L)
59	VOL (B)	I	Volume encoder signal input
60	VOL (A)	I	Volume encoder signal input
61	DIN	O	Serial data output for FL driver IC
62	CLK	O	Clock signal output for FL driver IC
63	FL_STB	O	Latch signal output for FL driver IC
64	NC	—	Not used (Fixed at L)
65	POWER RELAY	O	Power relay driver control signal output
66	PROTECTOR	O	Protector detection signal output
67	HEADPHONE RELAY	O	Headphone relay driver control signal output
68	WOOFER RELAY	O	Sub woofer relay driver control signal output
69	REAR RELAY	O	Surround speaker relay driver control signal output
70	CENTER RELAY	O	Center speaker relay driver control signal output
71	PREOUT/FRONT RELAY	O	Speaker A relay driver control signal output
72	R1 RELAY	O	Bridgeable relay driver control output (STR-DE595 only)
73	TUNED	I	Tuned signal detection input
74	STEREO	I	Stereo signal detection input
75	MUTE	O	Tuner mute signal output
76	DO	I	Tuner serial data input
77	RSTX	I	Reset signal input
78	SLATCH	O	Tuner latch signal output
79	X0A	—	Not used (Open)
80	X1A	—	Not used (Connect to VSS)
81	VSS	—	Ground
82	X0	—	Clock signal input (16 MHz)
83	X1	—	Clock signal output (16 MHz)
84	VCC3	—	Power supply pin (+3.3 V)
85, 86	NC	—	Not used (Fixed at L)
87 to 90	SW4 to SW1	O	Video select signal output
91, 92	NC	—	Not used (Fixed at L)
93	XMODE	O	Xmode signal output for DIR IC
94	CKSEL1	O	Clock select signal output for DIR IC
95	CLK	O	Data clock signal output for DIR IC
96	CE	O	Latch signal output for DIR IC
97	DI	O	Data output for DIR IC
98	DO	I	Data input from DIR IC
99	ERROR	I	Error detection signal input from DIR IC
100	XSTATE	I	Xstate signal input from DIR IC

4-2. CIRCUIT BOARDS LOCATION

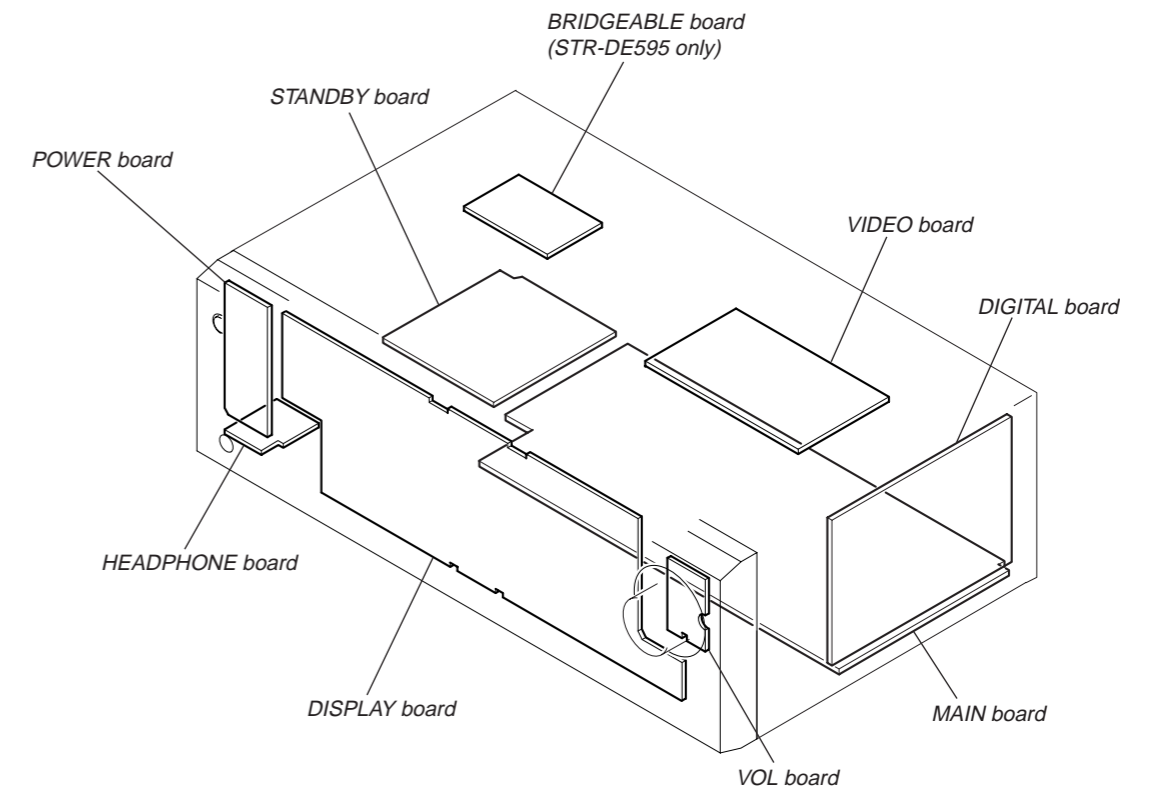

4-3. BLOCK DIAGRAM — TUNER/AUDIO SECTION —

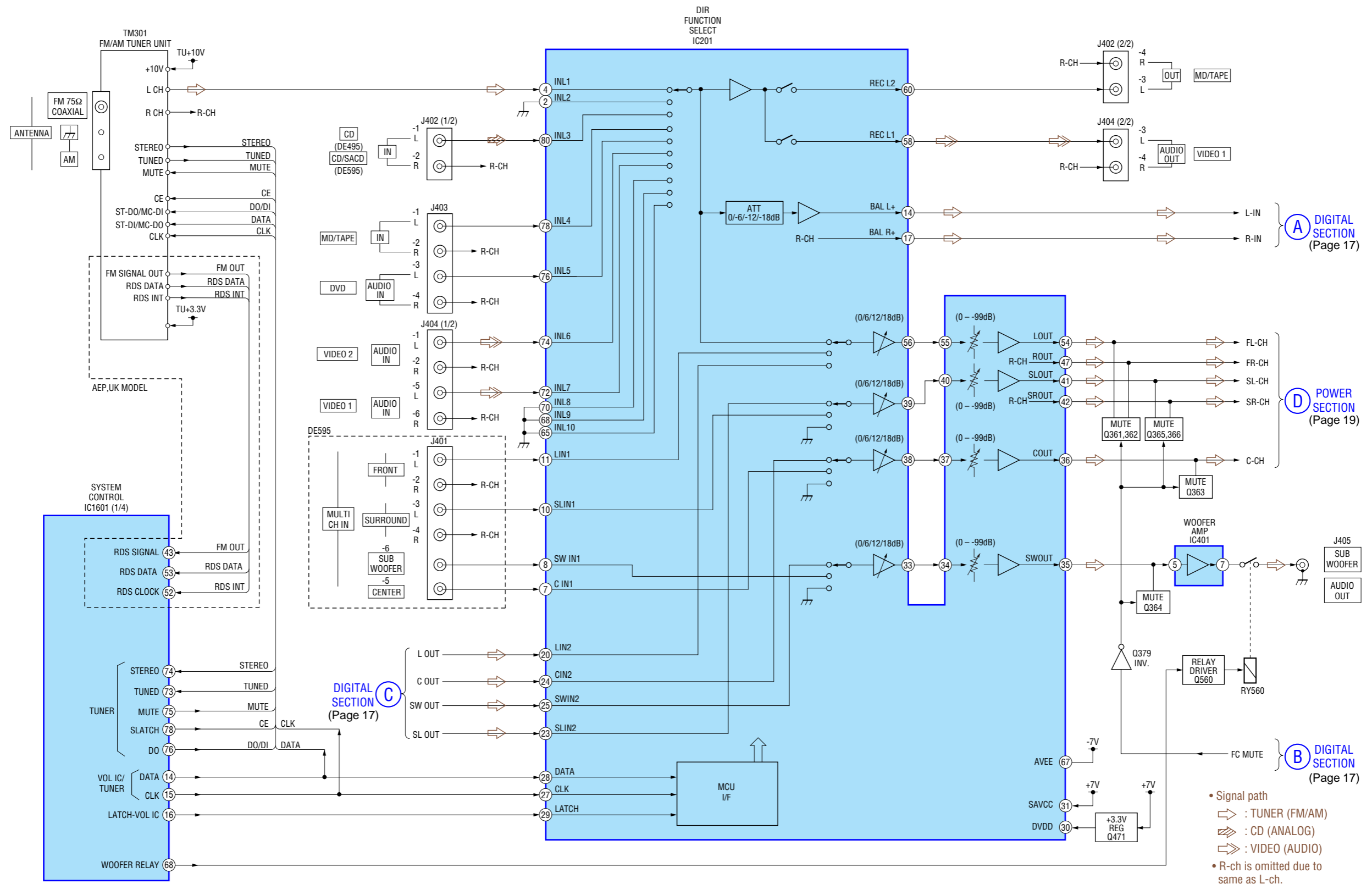

4-4. BLOCK DIAGRAM — DIGITAL SECTION —

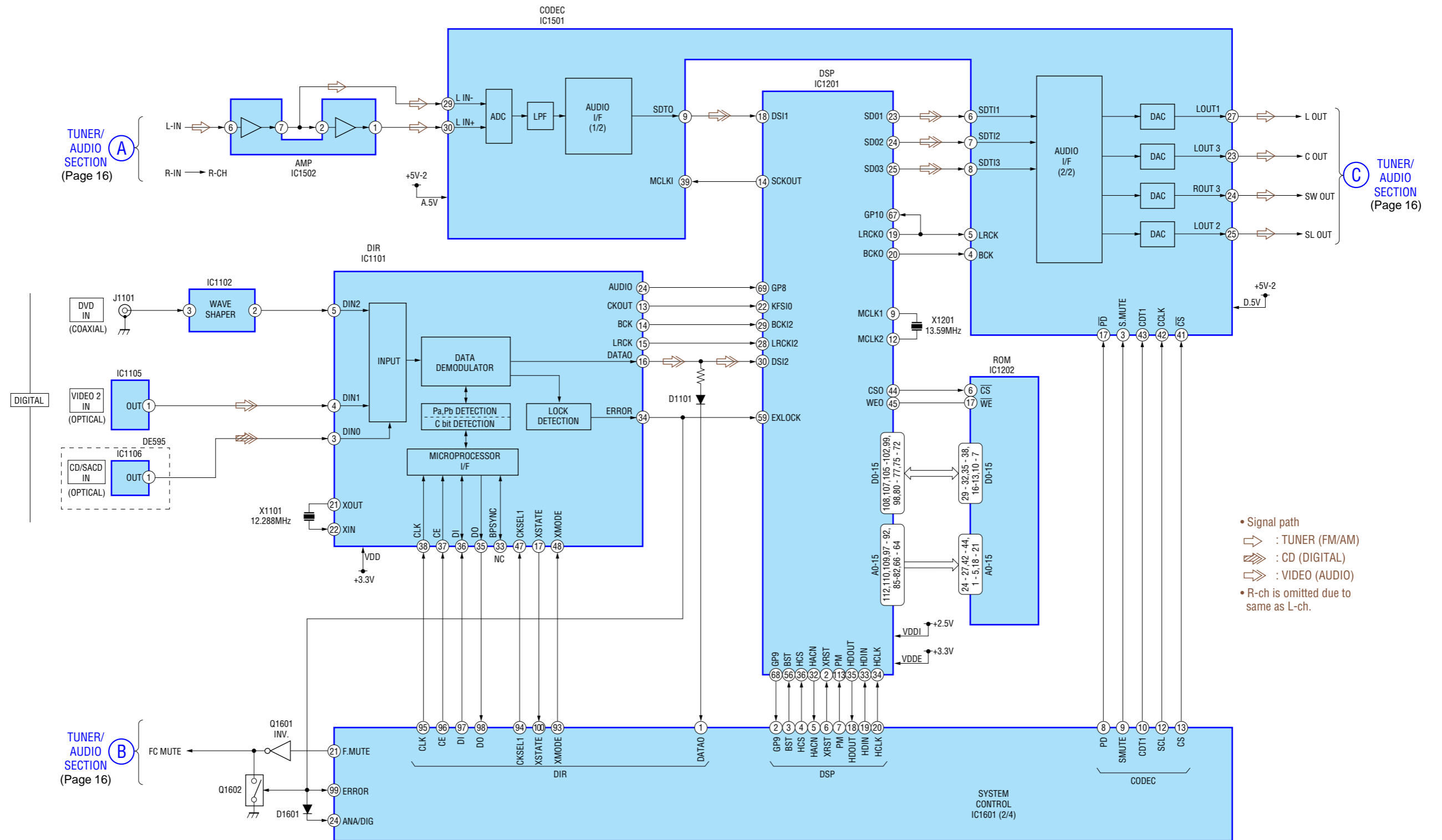

4-5. BLOCK DIAGRAM — VIDEO/DISPLAY SECTION —

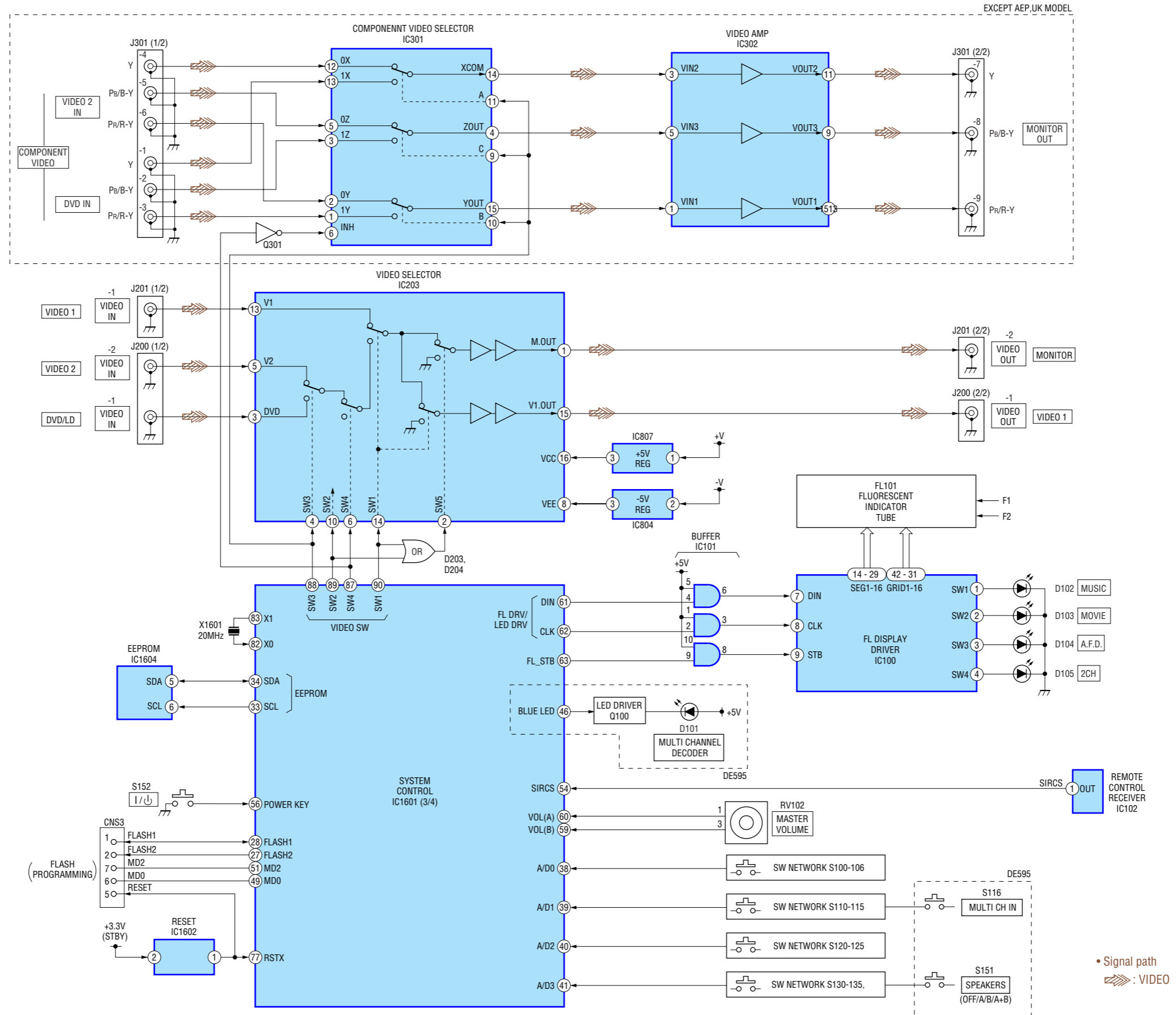

4-6. BLOCK DIAGRAM — POWER SECTION —

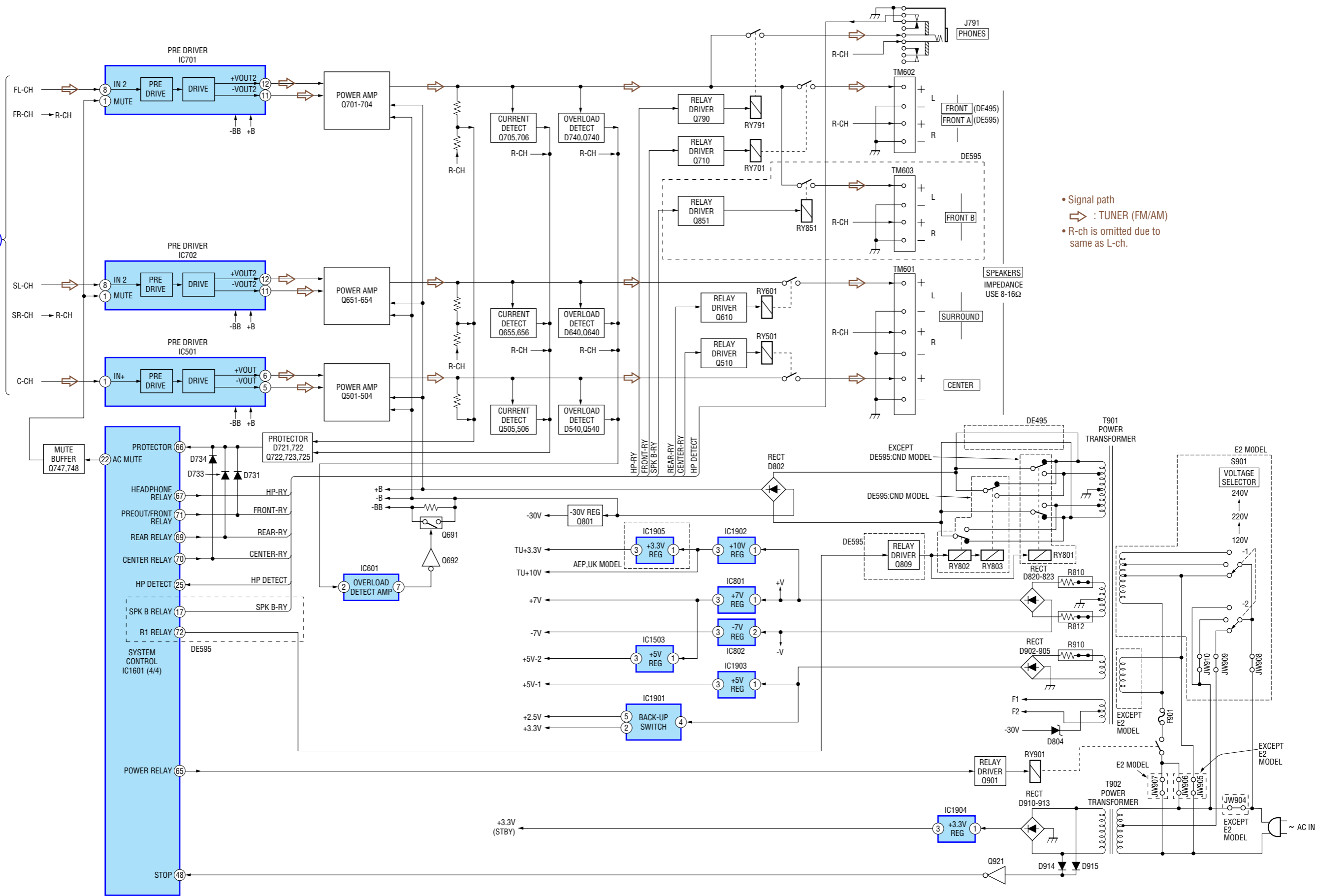

TUNER/AUDIO SECTION (Page 16)

- Signal path
- ➡ : TUNER (FM/AM)
- R-ch is omitted due to same as L-ch.









THIS NOTE IS COMMON FOR PRINTED WIRING BOARDS AND SCHEMATIC DIAGRAMS.
(In addition to this, the necessary note is printed in each block.)

for schematic diagram:



- All capacitors are in μF unless otherwise noted. pF: $\mu\mu\text{F}$ 50 WV or less are not indicated except for electrolytics and tantalums.
- All resistors are in Ω and $1/4\text{ W}$ or less unless otherwise specified.
- Δ : internal component.
-  : nonflammable resistor.
-  : fusible resistor.
-  : panel designation.

Note:
The components identified by mark Δ or dotted line with mark Δ are critical for safety.
Replace only with part number specified.

Note:
Les composants identifiés par une marque Δ sont critiques pour la sécurité.
Ne les remplacer que par une pièce portant le numéro spécifié.

-  : B+ Line.
-  : B- Line.
- Voltage and waveforms are dc with respect to ground under no-signal (detuned) conditions.
no mark : FM
- Voltages are taken with a VOM (Input impedance 10 M Ω).
Voltage variations may be noted due to normal production tolerances.
- Waveforms are taken with a oscilloscope.
Voltage variations may be noted due to normal production tolerances.
- Circled numbers refer to waveforms.
- Signal path.
 -  : TUNER (FM/AM)
 -  : VIDEO (AUDIO)
 -  : VIDEO
 -  : CD (ANALOG)
 -  : CD (DIGITAL)
- Abbreviation
 - CND : Canadian model.
 - AUS : Australian model.
 - MX : Mexican model.
 - SP : Singapore model.
 - E2 : AC 120 V area in E model.
 - AR : Argentine model.
 - KR : Korean model.
 - TW : Taiwan model.

for printed wiring boards:

-  : parts extracted from the component side.
- Δ : internal component.
-  : Pattern from the side which enables seeing.

Caution:

Pattern face side: Parts on the pattern face side seen from the (Side B) pattern face are indicated.
Parts face side: Parts on the parts face side seen from the (Side A) parts face are indicated.

- Abbreviation
 - CND : Canadian model.
 - AUS : Australian model.
 - MX : Mexican model.
 - SP : Singapore model.
 - E2 : AC 120 V area in E model.
 - AR : Argentine model.
 - KR : Korean model.
 - TW : Taiwan model.

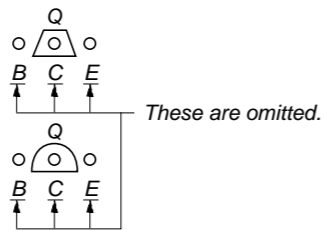
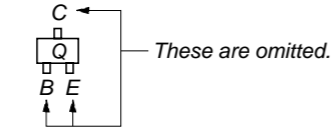

• Waveforms (DIGITAL Board)

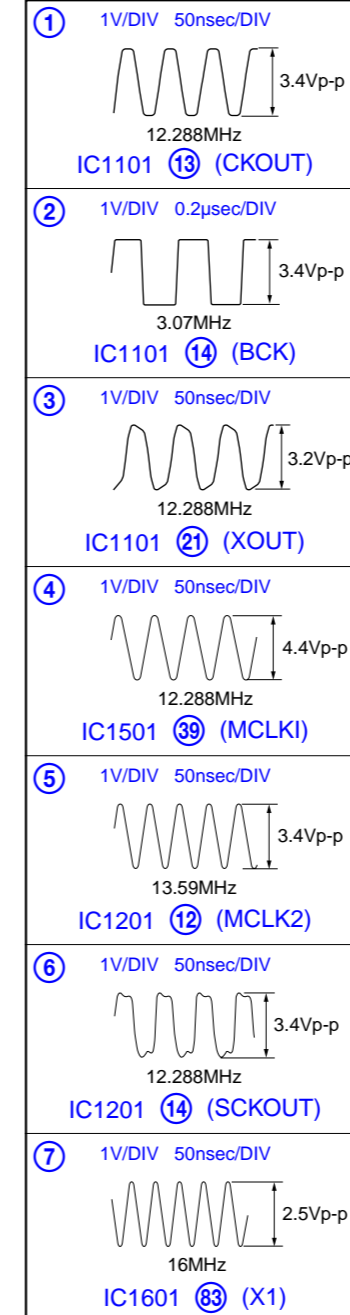

4-7. PRINTED WIRING BOARDS — MAIN SECTION — • Refer to page 15 for Circuit Boards Location and page 20 for Common Note on Printed Wiring Boards.

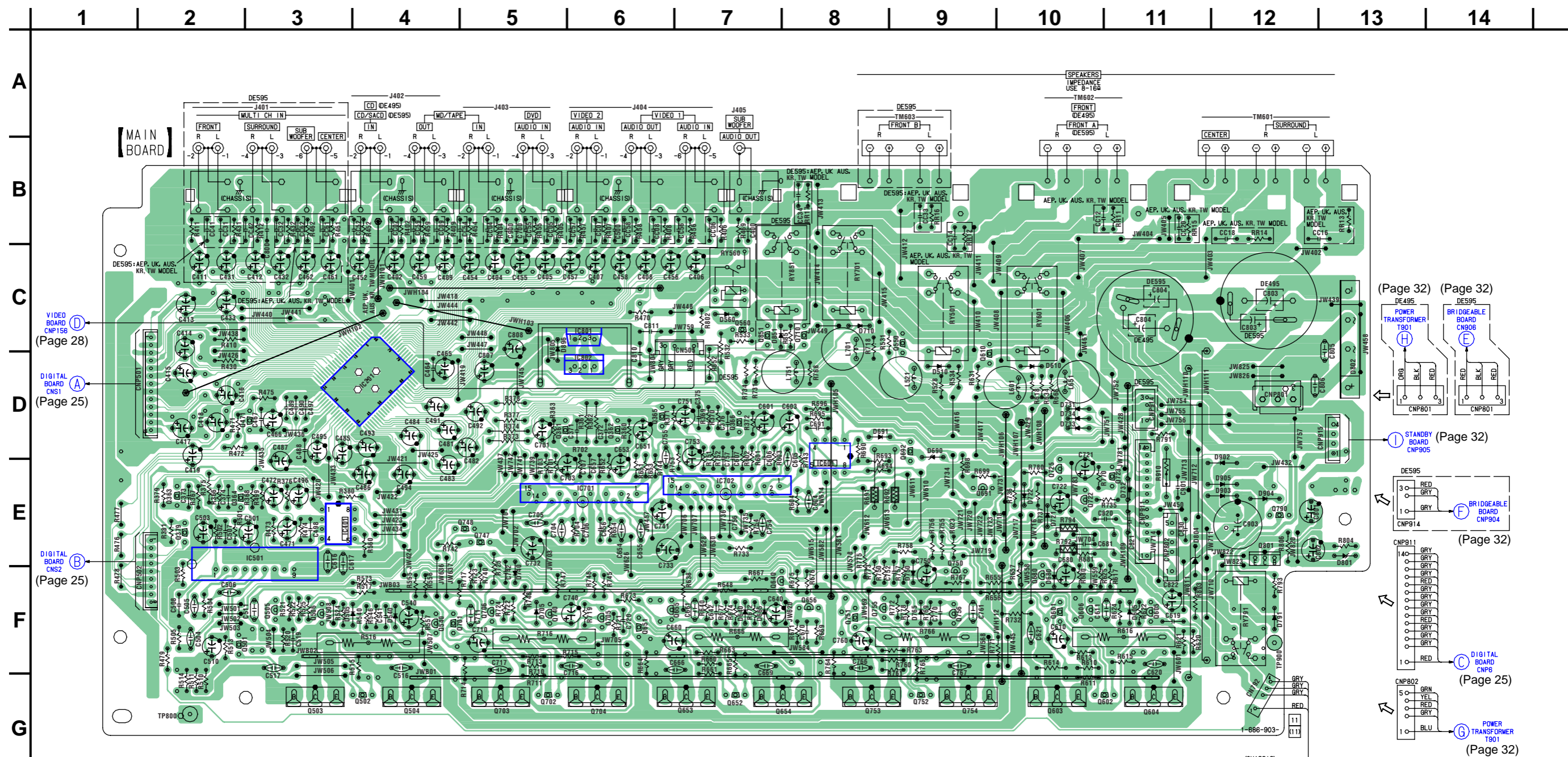

• Semiconductor Location

Ref. No.	Location	Ref. No.	Location	Ref. No.	Location	Ref. No.	Location	Ref. No.	Location
D505	F-3	D750	F-9	IC802	D-6	Q602	G-10	Q705	F-6
D510	D-9	D765	F-9			Q603	G-10	Q706	F-5
D540	F-4	D791	F-12	Q361	D-5	Q604	G-11	Q710	C-8
D560	C-7	D801	E-13	Q362	D-6	Q605	F-11	Q722	E-10
D605	F-11	D802	D-13	Q363	E-2	Q606	F-10	Q723	E-10
D610	D-10	D804	E-11	Q364	E-2	Q610	C-9	Q725	E-10
D640	F-7	(D851)	C-7	Q365	D-6	Q640	F-7	Q740	F-5
D665	F-7	D896	C-5	Q366	C-5	Q651	F-6	Q747	E-5
D680	E-10	D902	E-12	Q379	E-2	Q652	G-7	Q748	E-5
D690	D-9	D903	E-12	Q471	D-2	Q653	G-7	Q750	E-9
D691	D-8	D904	E-12	Q501	F-2	Q654	G-8	Q751	F-8
D705	F-5	D905	E-12	Q502	C-4	Q655	F-6	Q752	G-9
D710	C-8			Q503	G-3	Q656	F-8	Q753	G-8
D721	E-10	IC201	D-4	Q504	G-4	Q680	D-10	Q754	G-9
D722	E-10	IC401	E-3	Q505	F-3	Q691	E-9	Q755	F-8
D731	D-10	IC501	E-3	Q506	F-3	Q692	D-9	Q756	F-9
D732	E-11	IC601	E-8	Q540	F-4	Q701	F-4	Q790	F-12
D733	D-10	IC701	E-6	Q550	C-9	Q702	G-5	Q801	F-12
D734	D-10	IC702	E-7	Q560	C-7	Q703	G-5	(Q851)	F-6
D740	E-5	IC801	C-6	Q601	F-10	Q704	G-6		

() : STR-DE595 only

4-8. SCHEMATIC DIAGRAM — MAIN SECTION (1/2) — • Refer to page 20 for Common Note on Schematic Diagram and page 34 for IC Block Diagrams.

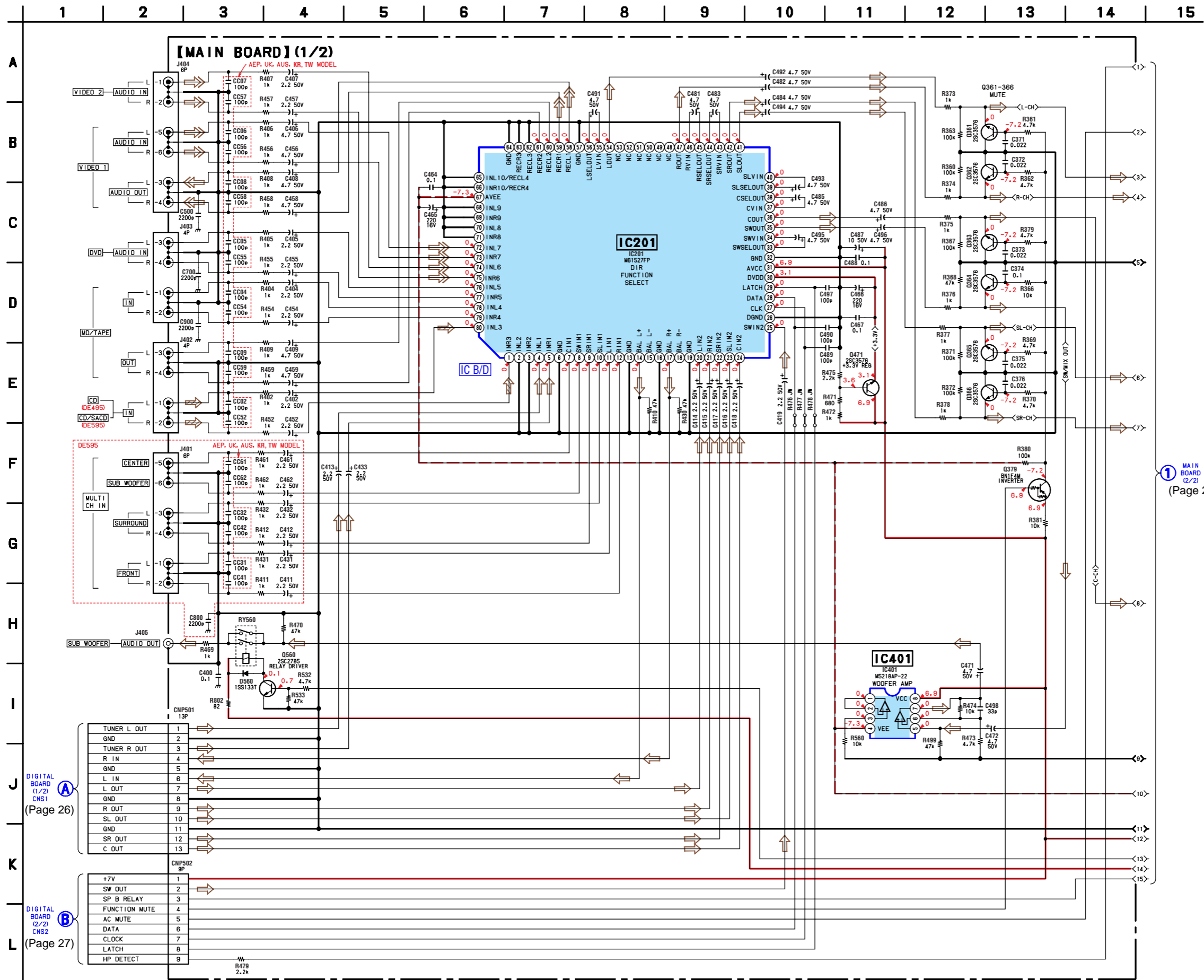

1 MAIN BOARD (2/2)
(Page 23)

4-9. SCHEMATIC DIAGRAM — MAIN SECTION (2/2) — • Refer to page 20 for Common Note on Schematic Diagram and page 34 for IC Block Diagrams.

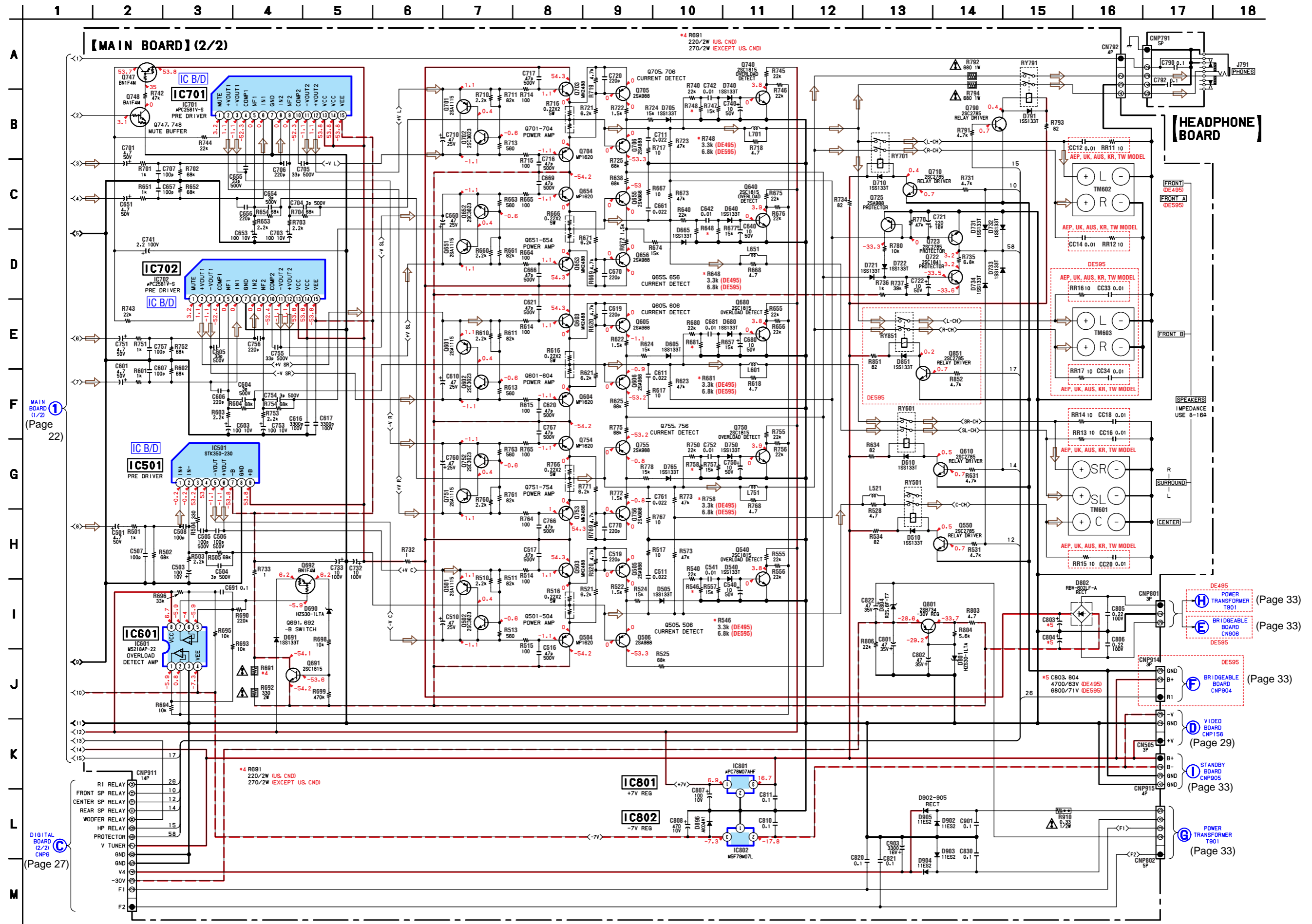

Note:
The components identified by mark Δ or dotted line with mark Δ are critical for safety. Replace only with part number specified.

Note:
Les composants identifiés par une marque Δ sont critiques pour la sécurité. Ne les remplacer que par une pièce portant le numéro spécifié.

4-10. PRINTED WIRING BOARD — DIGITAL SECTION (1/2) — • Refer to page 15 for Circuit Boards Location and page 20 for Common Note on Printed Wiring Boards.

13 | 12 | 11 | 10 | 9 | 8 | 7 | 6 | 5 | 4 | 3 | 2 | 1

A
B
C
D
E
F
G
H
I
J

【DIGITAL BOARD】(SIDE A)

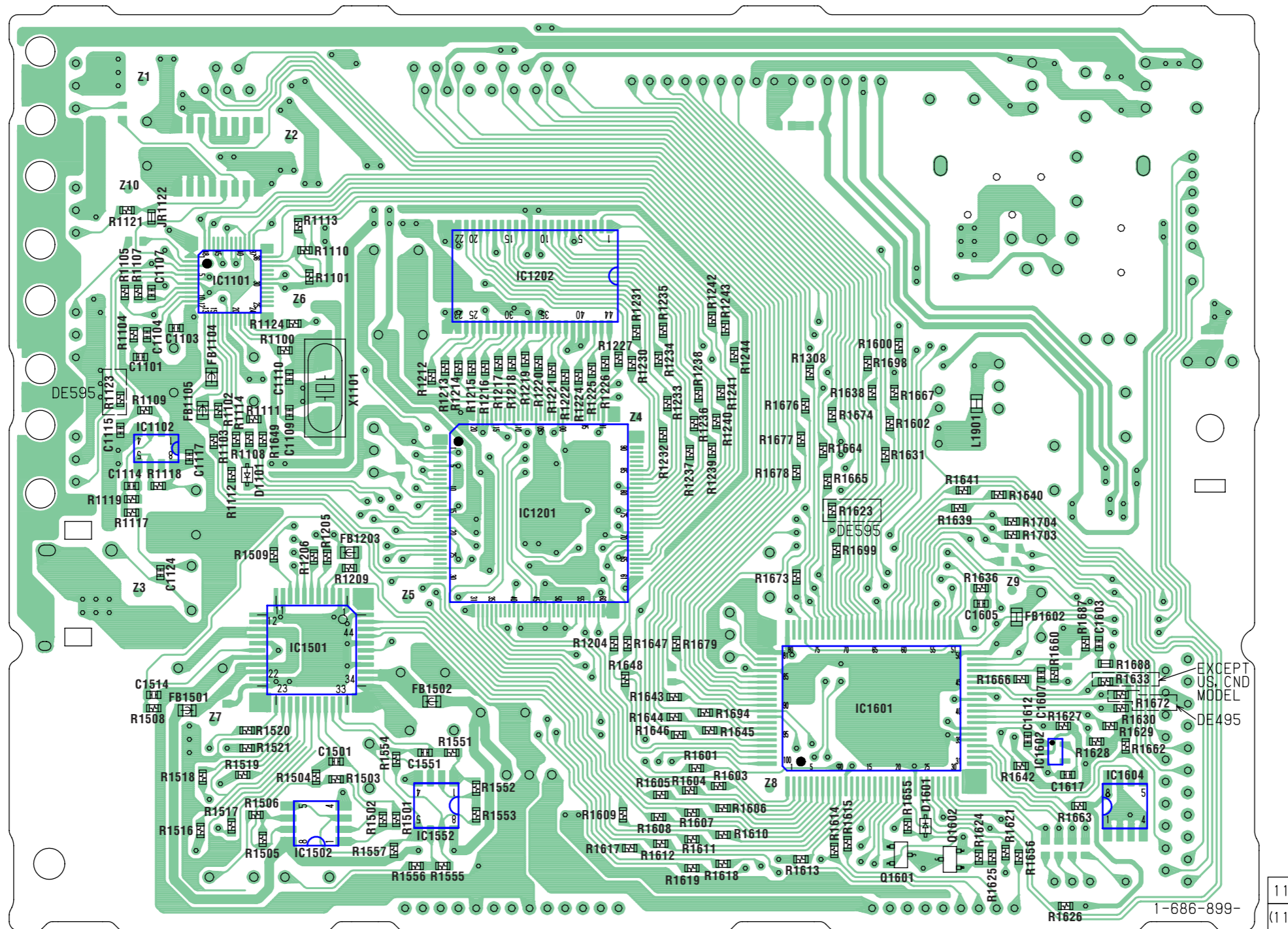

• Semiconductor Location (Side A)

Ref. No.	Location
D1101	F-10
D1601	I-5
IC1101	D-10
IC1102	F-11
IC1201	F-8
IC1202	D-8
IC1501	G-10
IC1502	I-10
IC1552	I-9
IC1601	H-5
IC1602	H-4
IC1604	I-3
Q1601	I-5
Q1602	I-4

EXCEPT
U.S. CND
MODEL
DE495

1-686-899-

11
(11)

4-11. PRINTED WIRING BOARD — DIGITAL SECTION (2/2) — • Refer to page 15 for Circuit Boards Location and page 20 for Common Note on Printed Wiring Boards.

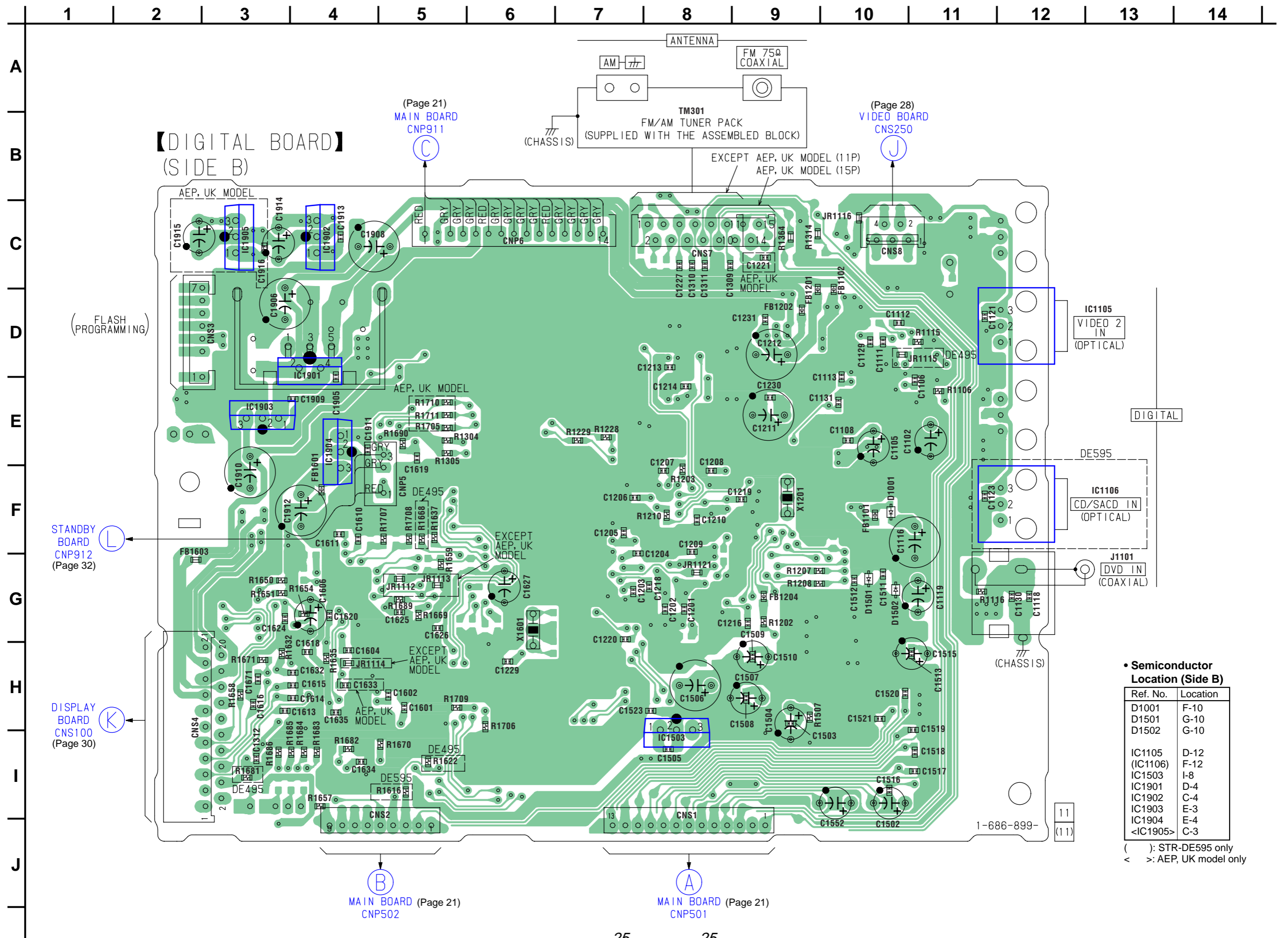

• Semiconductor Location (Side B)

Ref. No.	Location
D1001	F-10
D1501	G-10
D1502	G-10
IC1105	D-12
(IC1106)	F-12
IC1503	I-8
IC1901	D-4
IC1902	C-4
IC1903	E-3
IC1904	E-4
<IC1905>	C-3

(): STR-DE595 only
 < >: AEP, UK model only

4-12. SCHEMATIC DIAGRAM — DIGITAL SECTION (1/2) — • Refer to page 20 for Common Note on Schematic Diagram and Waveforms and page 34 for IC Block Diagrams.

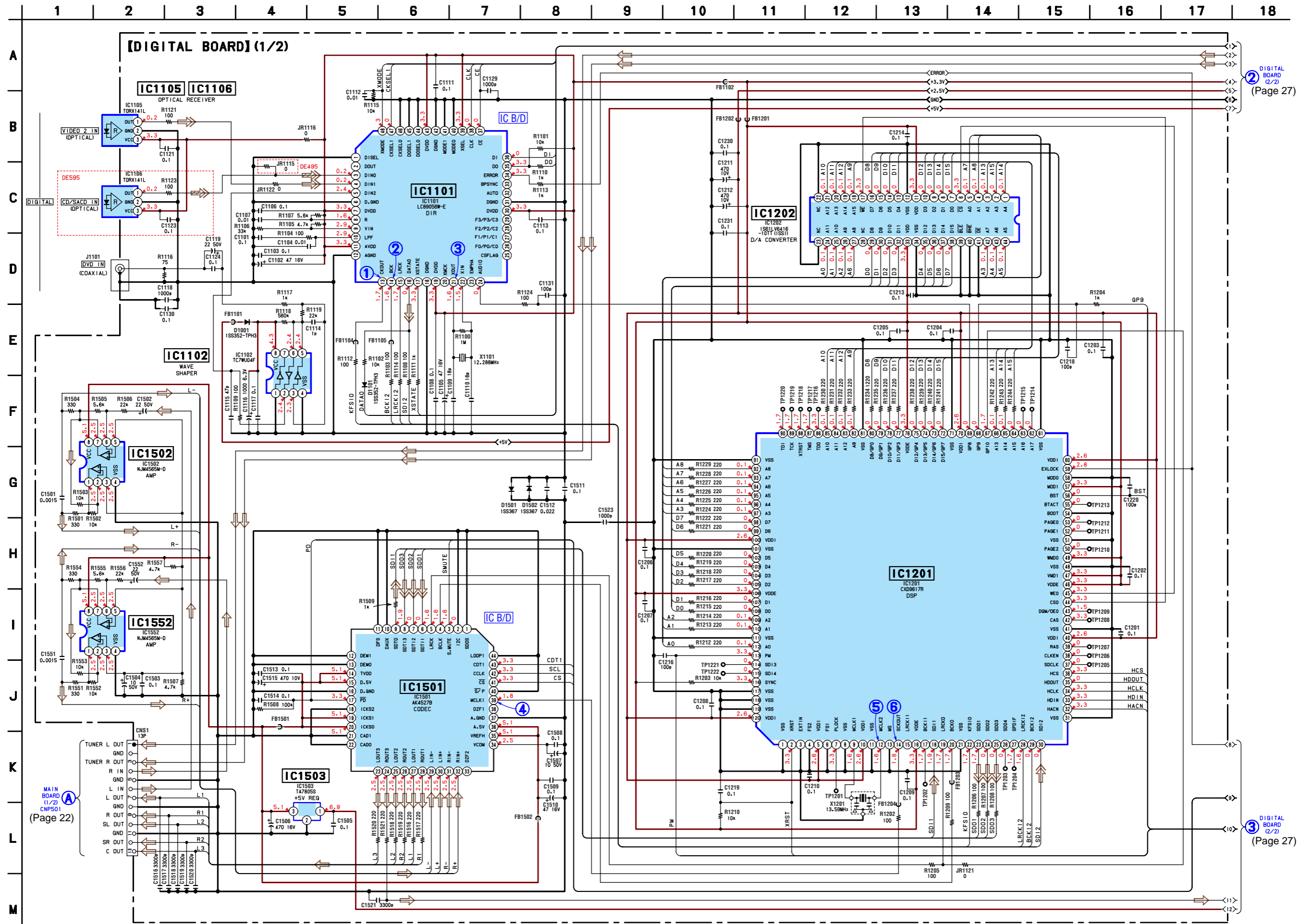

DIGITAL BOARD (2/2) (Page 27)

DIGITAL BOARD (2/2) (Page 27)

4-13. SCHEMATIC DIAGRAM — DIGITAL SECTION (2/2) — • Refer to page 20 for Common Note on Schematic Diagram and Waveforms.

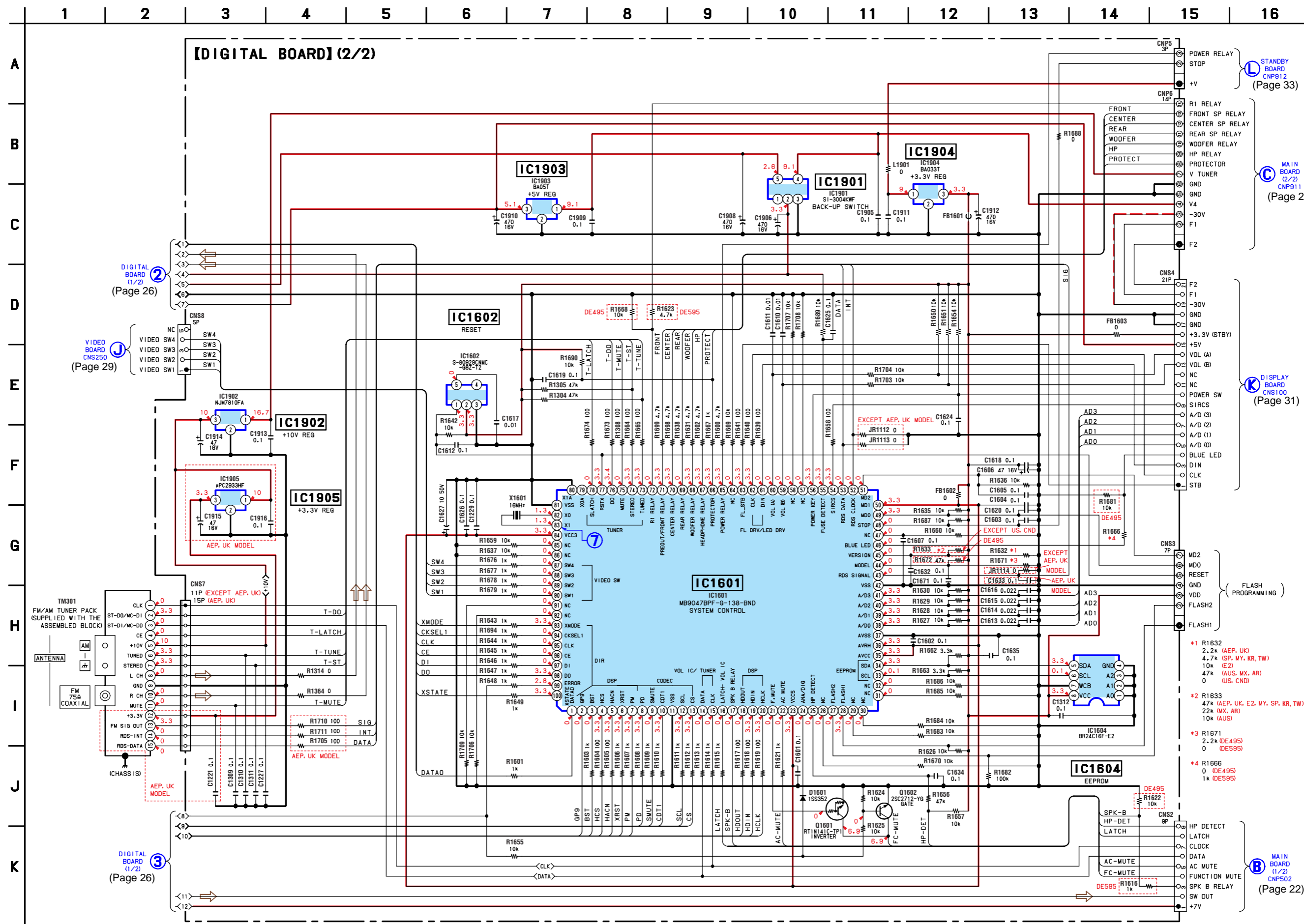

4-14. PRINTED WIRING BOARD — VIDEO SECTION — • Refer to page 15 for Circuit Boards Location and page 20 for Common Note on Printed Wiring Boards.



• Semiconductor Location

Ref. No.	Location
D203	G-4
D204	F-4
IC203	F-7
(IC301)	G-8
(IC302)	H-12
IC804	H-3
IC807	H-3
(Q301)	H-5

(): Except for AEP, UK model

EXCEPT DE495, DE595: AEP, UK MODEL

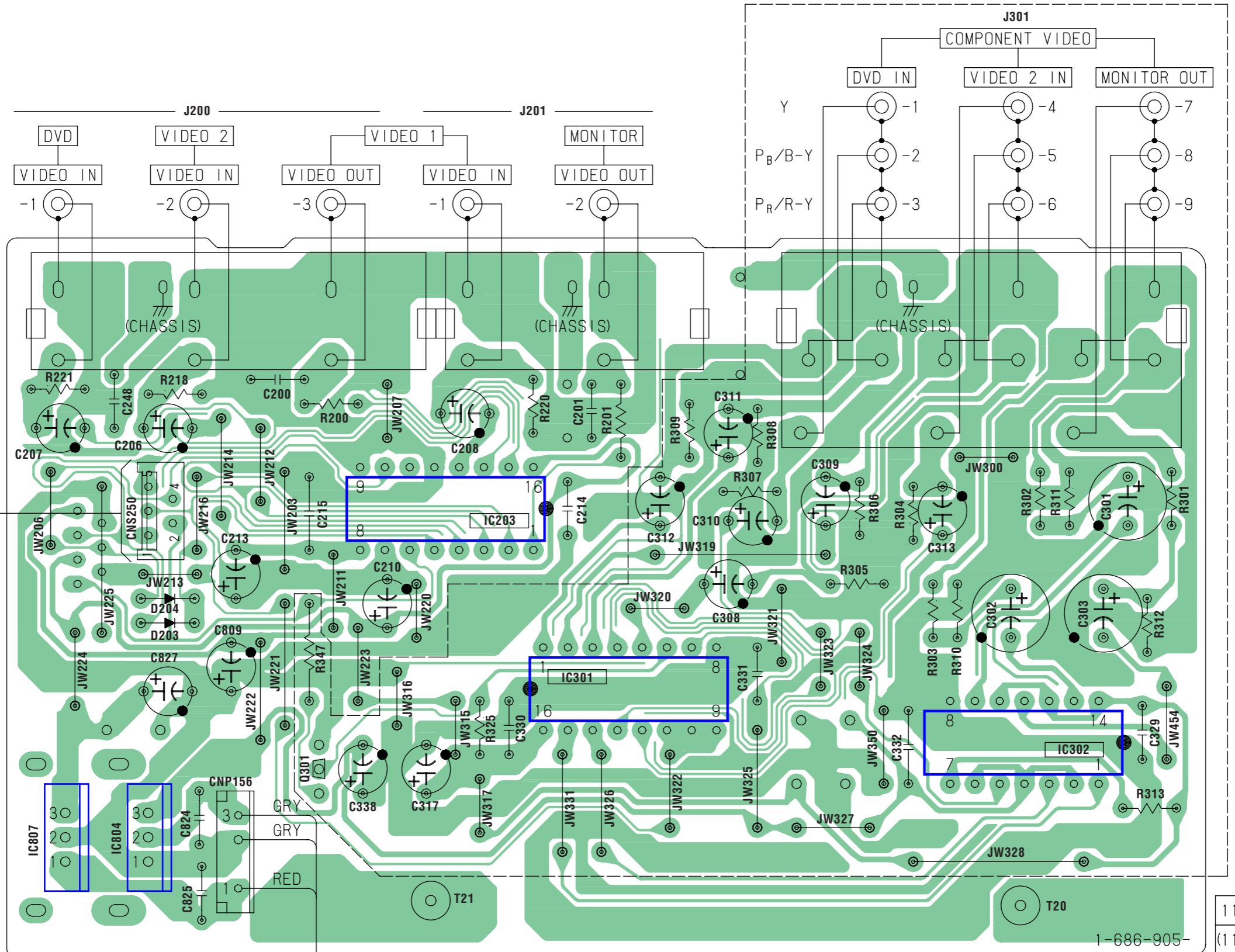

DIGITAL BOARD CNS8 (Page 25)

VIDEO BOARD

MAIN BOARD CNS505 (Page 21)

11
(11)

1-686-905-

4-15. SCHEMATIC DIAGRAM — VIDEO SECTION — • Refer to page 20 for Common Note on Schematic Diagram and page 34 for IC Block Diagrams.

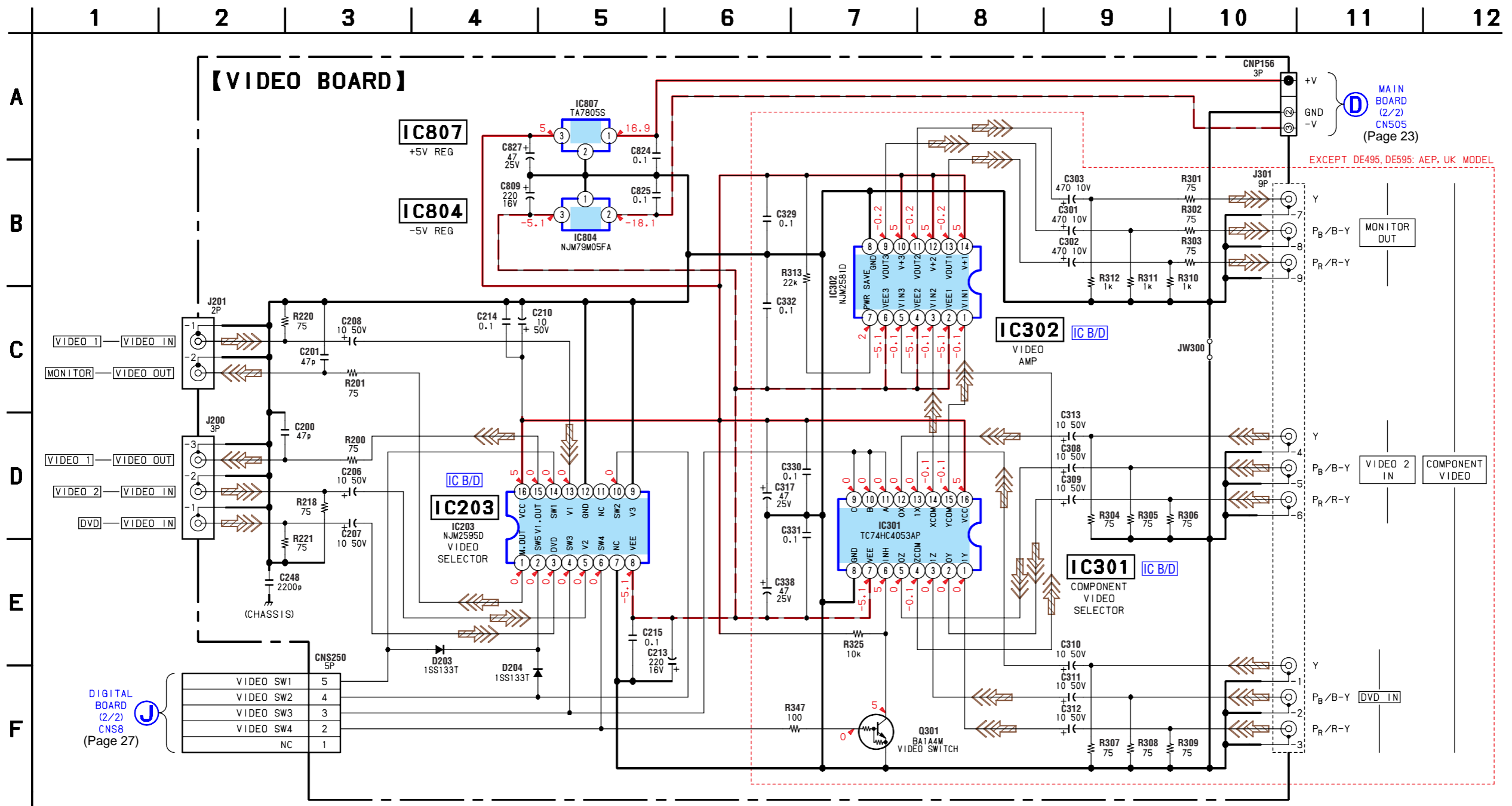

4-16. PRINTED WIRING BOARDS — DISPLAY SECTION — • Refer to page 15 for Circuit Boards Location and page 20 for Common Note on Printed Wiring Boards.

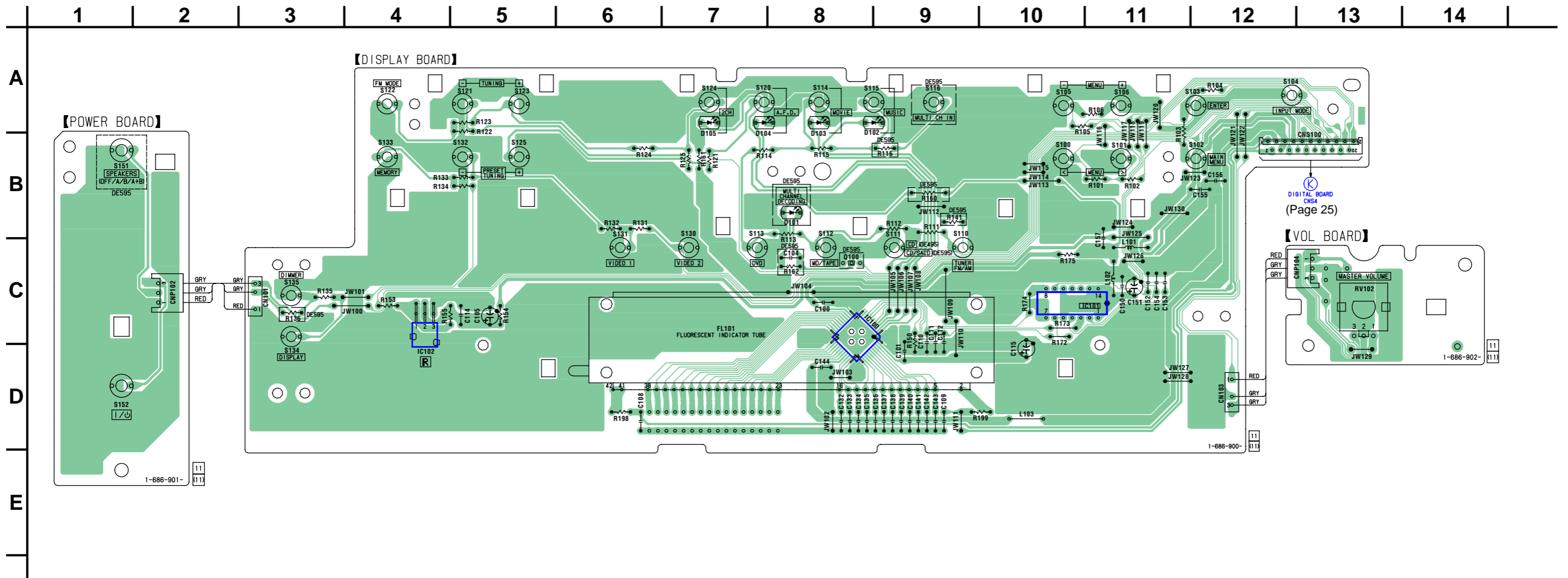

• Semiconductor Location

Ref. No.	Location
(D101)	B-8
D102	A-8
D103	A-8
D104	A-7
D105	A-7
IC100	C-8
IC101	C-10
IC102	C-4
(Q100)	C-8

(): STR-DE595 only

4-17. SCHEMATIC DIAGRAM — DISPLAY SECTION — • Refer to page 20 for Common Note on Schematic Diagram.

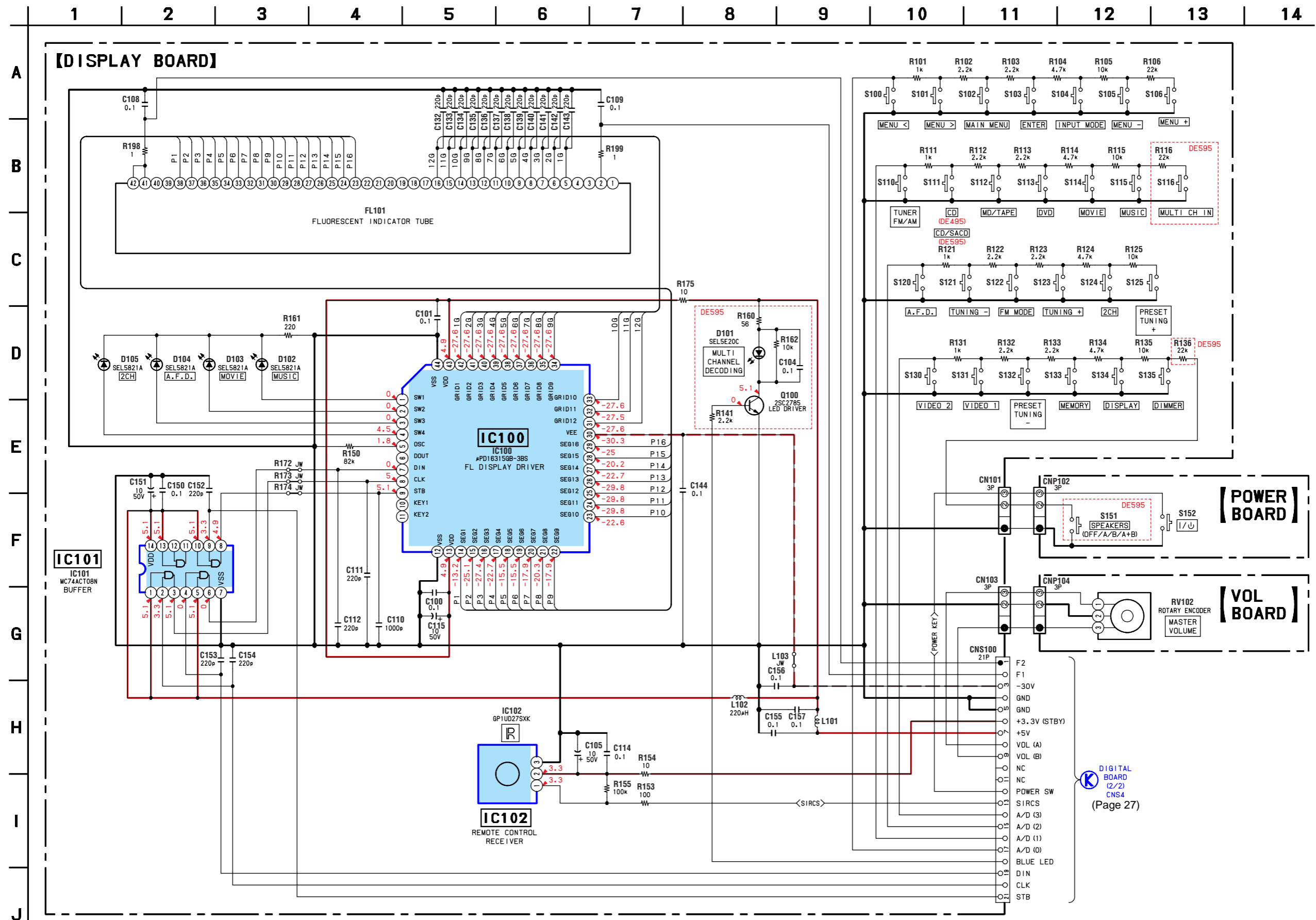

4-18. PRINTED WIRING BOARDS — POWER SECTION — • Refer to page 15 for Circuit Boards Location and page 20 for Common Note on Printed Wiring Boards.

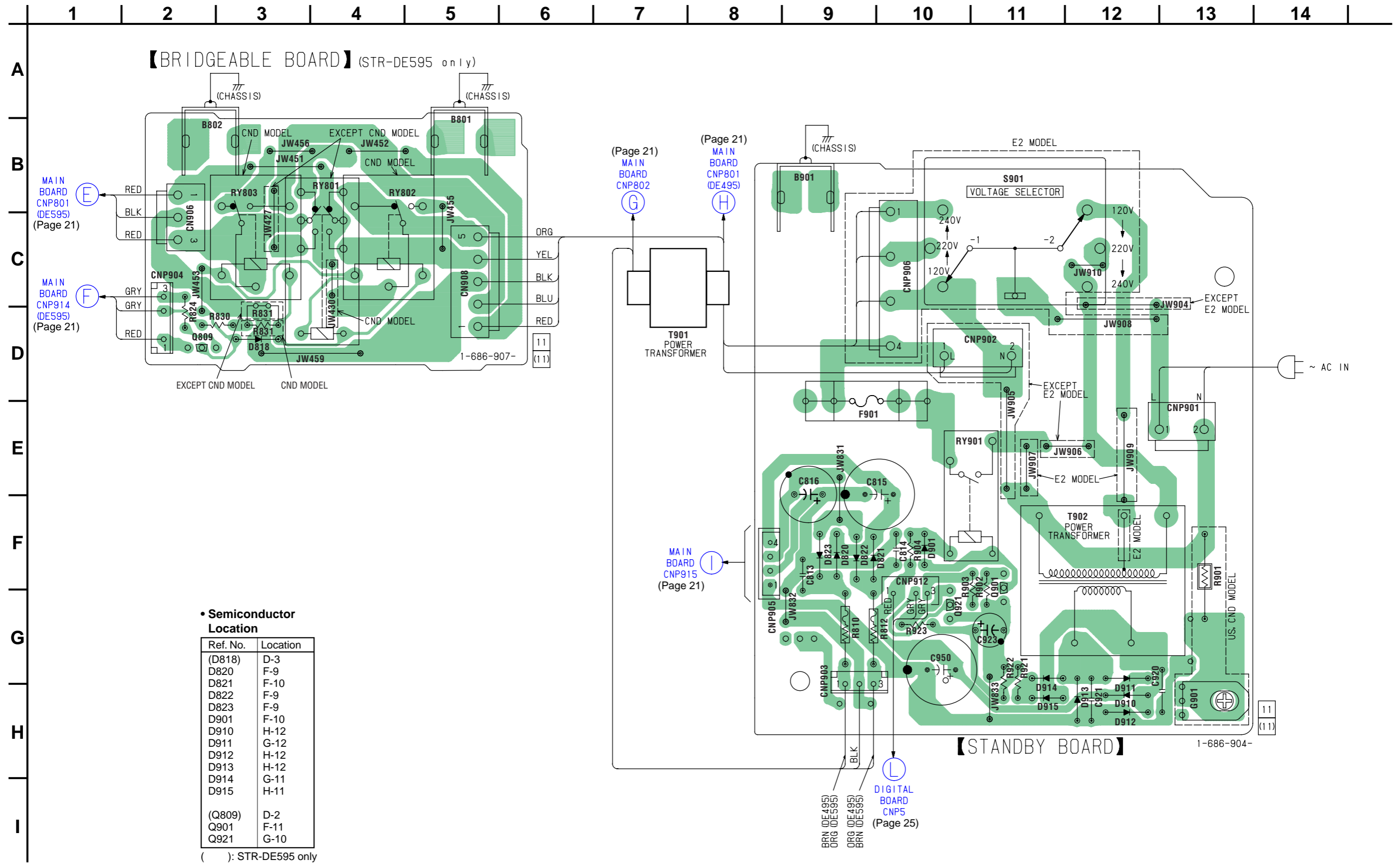

4-19. SCHEMATIC DIAGRAM — POWER SECTION — • Refer to page 20 for Common Note on Schematic Diagram.

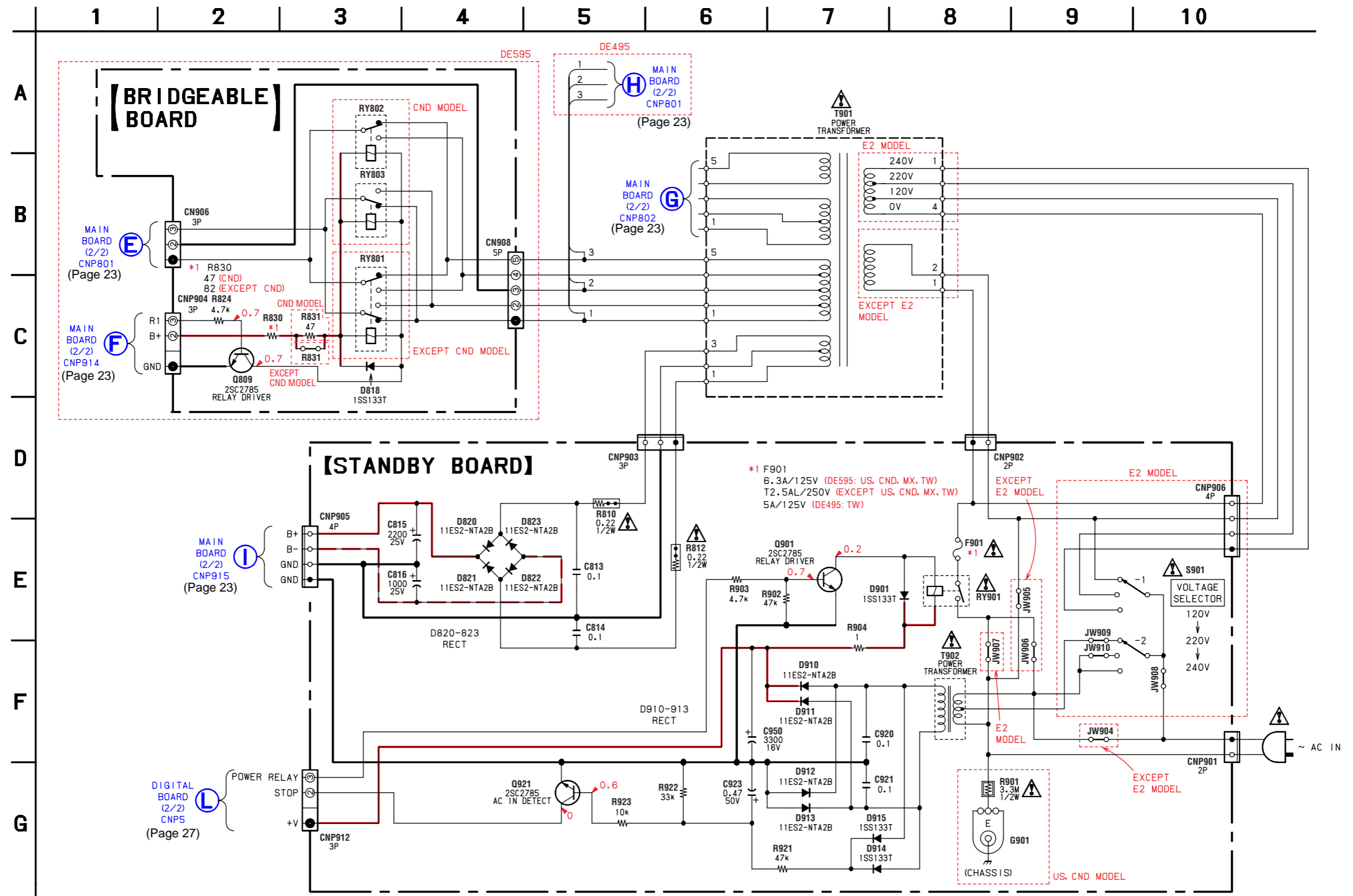

Note:
The components identified by mark Δ or dotted line with mark Δ are critical for safety. Replace only with part number specified.

Note:
Les composants identifiés par une marque Δ sont critiques pour la sécurité. Ne les remplacer que par une pièce portant le numéro spécifié.

4-20. IC BLOCK DIAGRAMS

IC201 M61527FP (MAIN BOARD (1/2))

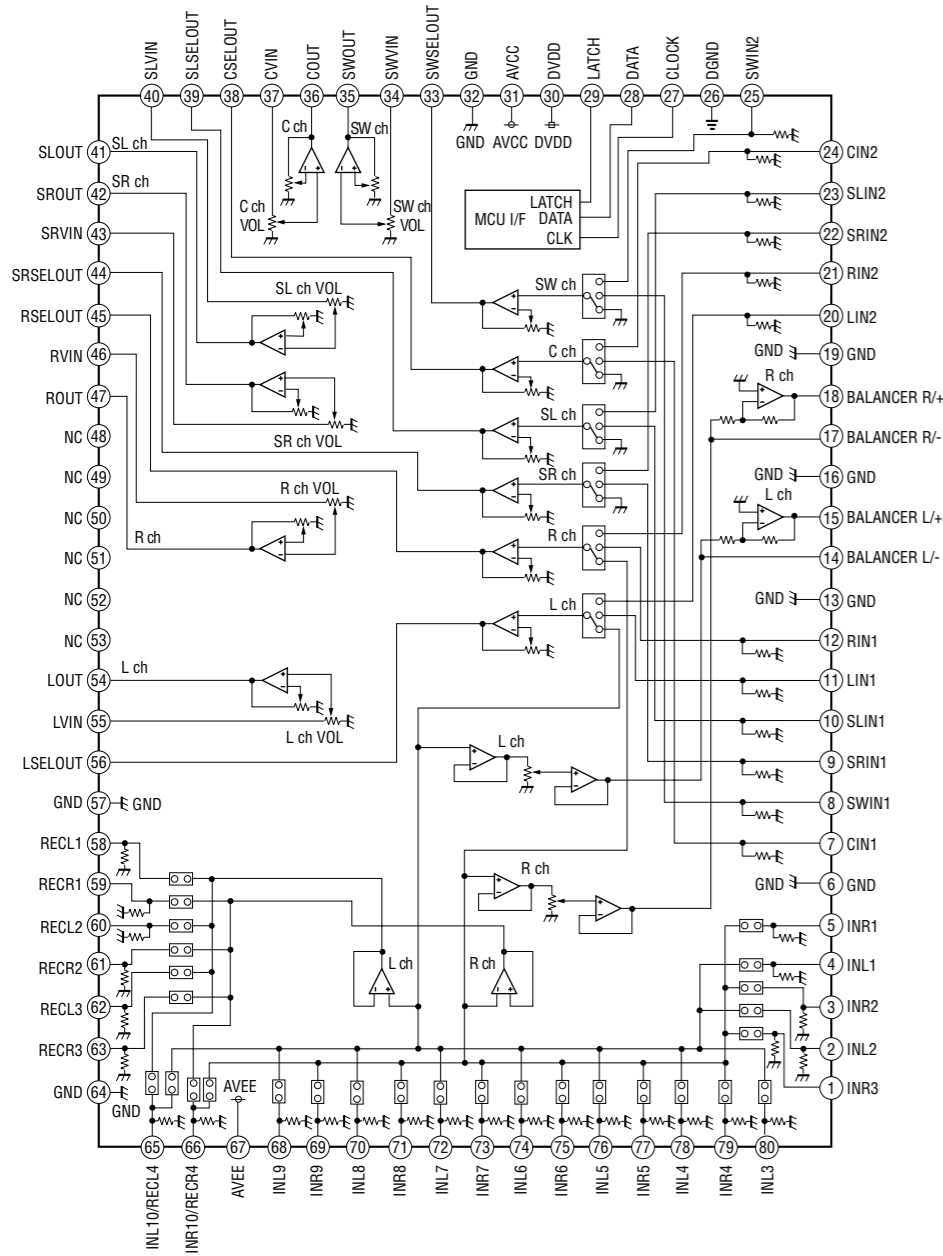

IC501 STK350-230 (MAIN BOARD (2/2))

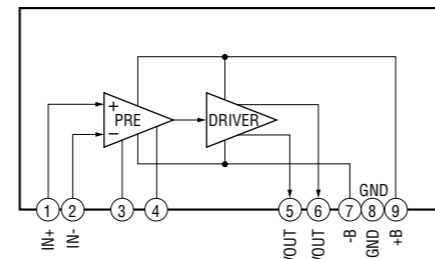

IC701 μPC2581V-S (MAIN BOARD (2/2))
IC702 μPC2581V-S (MAIN BOARD (2/2))

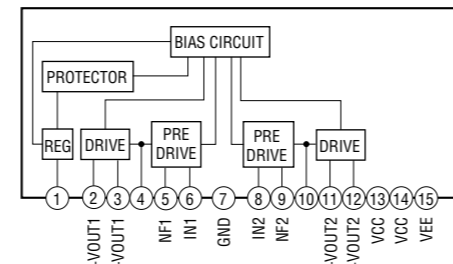

IC1501 AK4527B (DIGITAL BOARD (1/2))

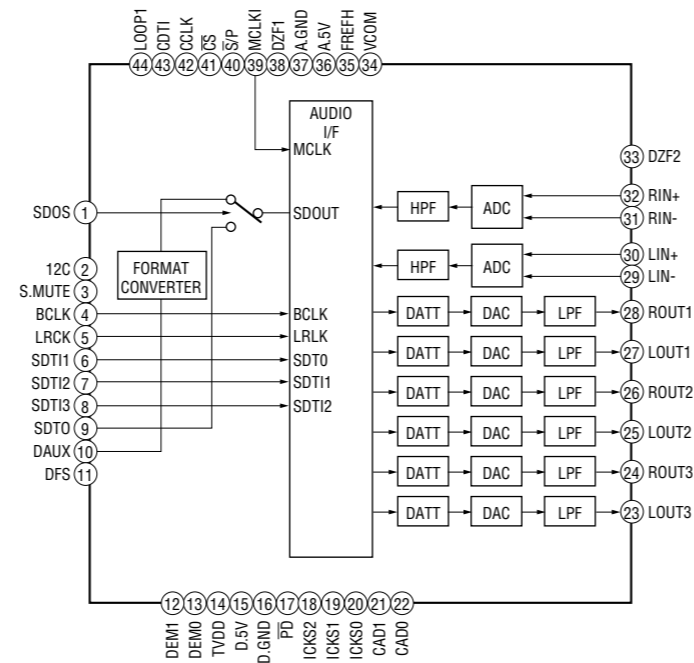

IC1101 LC89056W-E (DIGITAL BOARD (1/2))

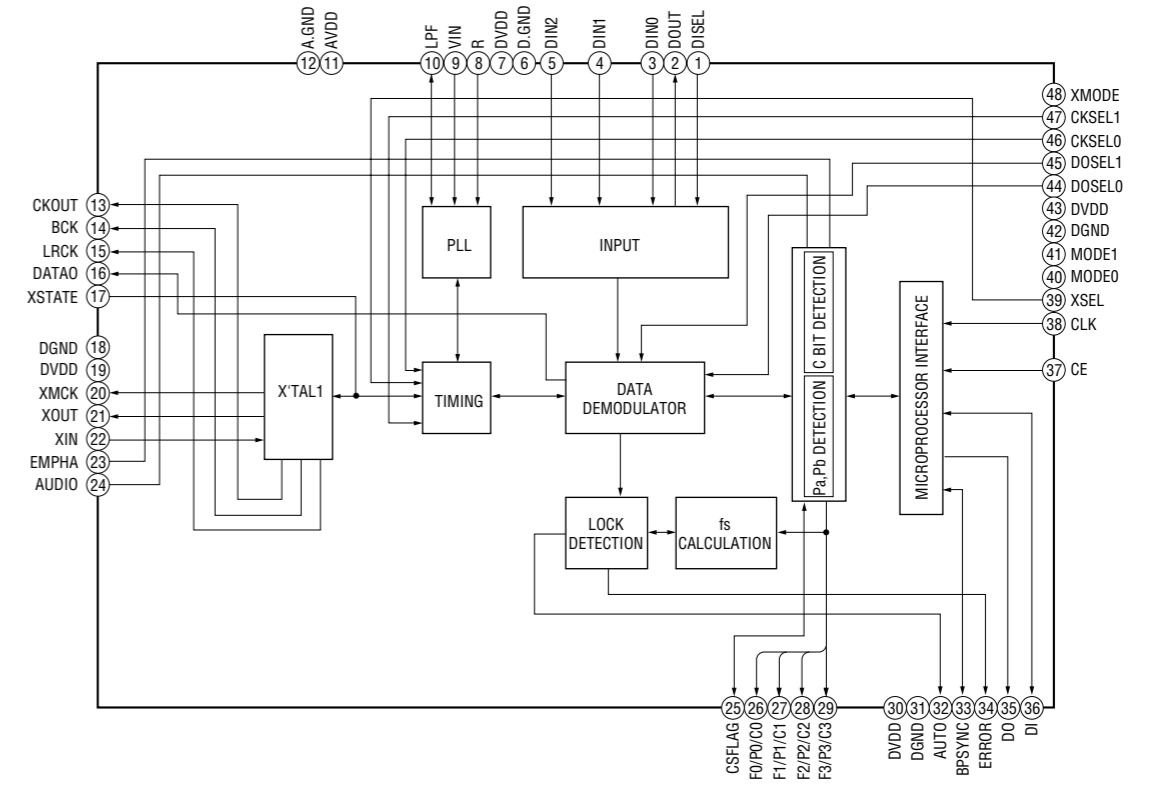

IC203 NJM2595D (VIDEO BOARD)

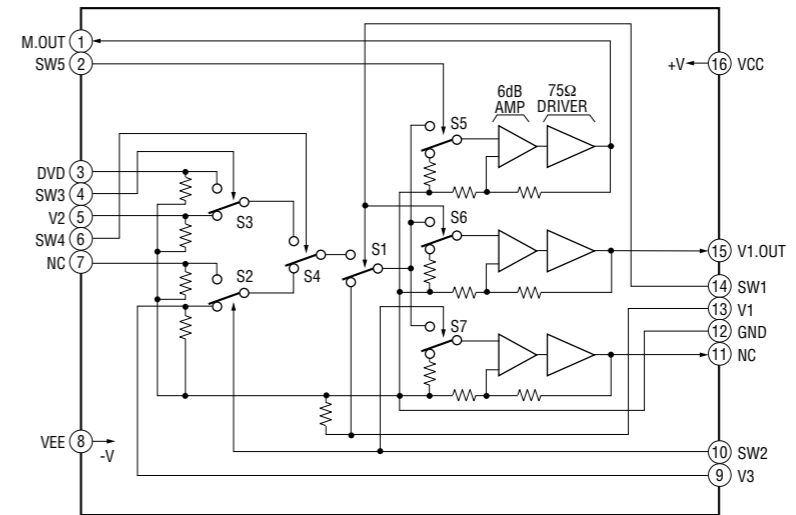

IC301 TC74HC4053AP

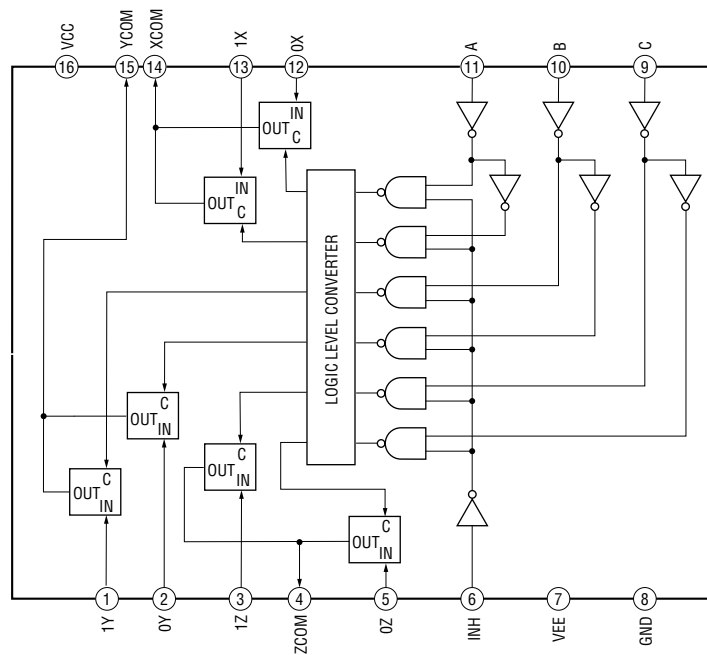

IC302 NJM2581D

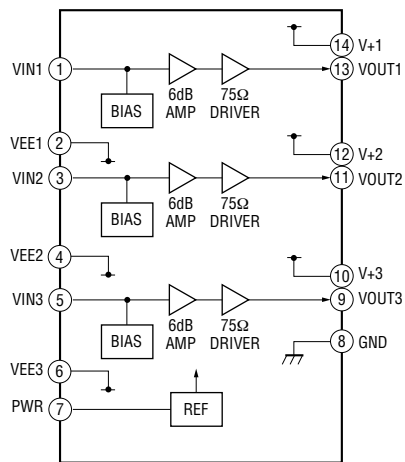

SECTION 5 EXPLODED VIEWS

NOTE:

- The mechanical parts with no reference number in the exploded views are not supplied.
- Items marked “*” are not stocked since they are seldom required for routine service. Some delay should be anticipated when ordering these items.
- Abbreviation
 CND : Canadian model
 AUS : Australian model
 MX : Mexican model
 SP : Singapore model
 E2 : AC 120 V area in E model
 AR : Argentine model
 KR : Korean model
 TW : Taiwan model

- -XX and -X mean standardized parts, so they may have some difference from the original one.
- Color Indication of Appearance Parts
 Example :
 KNOB, BALANCE (WHITE) ... (RED)

↑
↑

 Parts Color Cabinet's Color
- Accessories are given in the last of this parts list.

The components identified by mark Δ or dotted line with mark Δ are critical for safety. Replace only with part number specified.

Les composants identifiés par une marque Δ sont critiques pour la sécurité. Ne les remplacer que par une pièce portant le numéro spécifié.

5-1. CASE SECTION

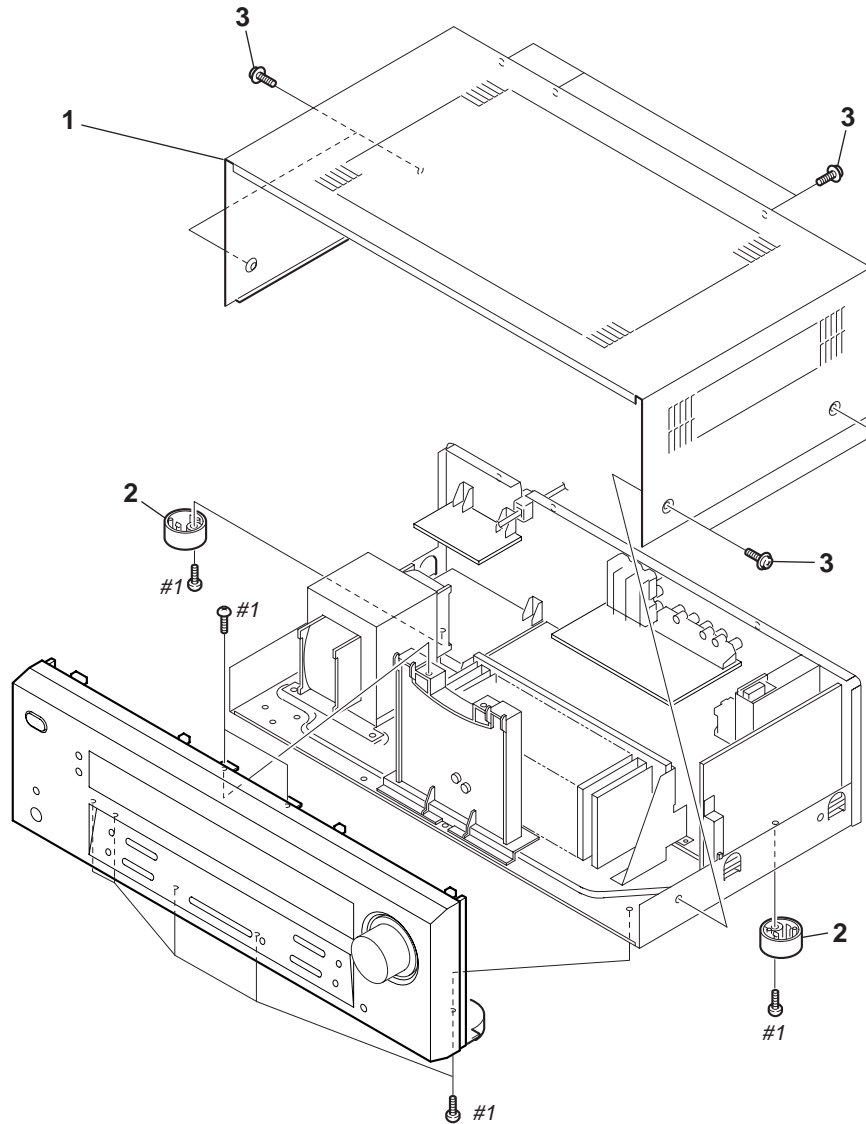

Ref. No.	Part No.	Description	Remark
1	4-245-939-01	CASE (BLACK)...(BLACK)	
1	4-245-939-21	CASE (SILVER)...(SILVER)	
1	4-245-939-41	CASE (GOLD)...(GOLD)	
2	X-4953-448-1	FOOT ASSY	

Ref. No.	Part No.	Description	Remark
3	4-210-291-01	SCREW (CASE 3 TP2) (BLACK)...(BLACK)	
3	4-210-291-11	SCREW (CASE 3 TP2) (SILVER)...(SILVER,GOLD)	
#1	7-685-646-79	SCREW +BVTP 3X8 TYPE2 IT-3	

5-2. FRONT PANEL SECTION

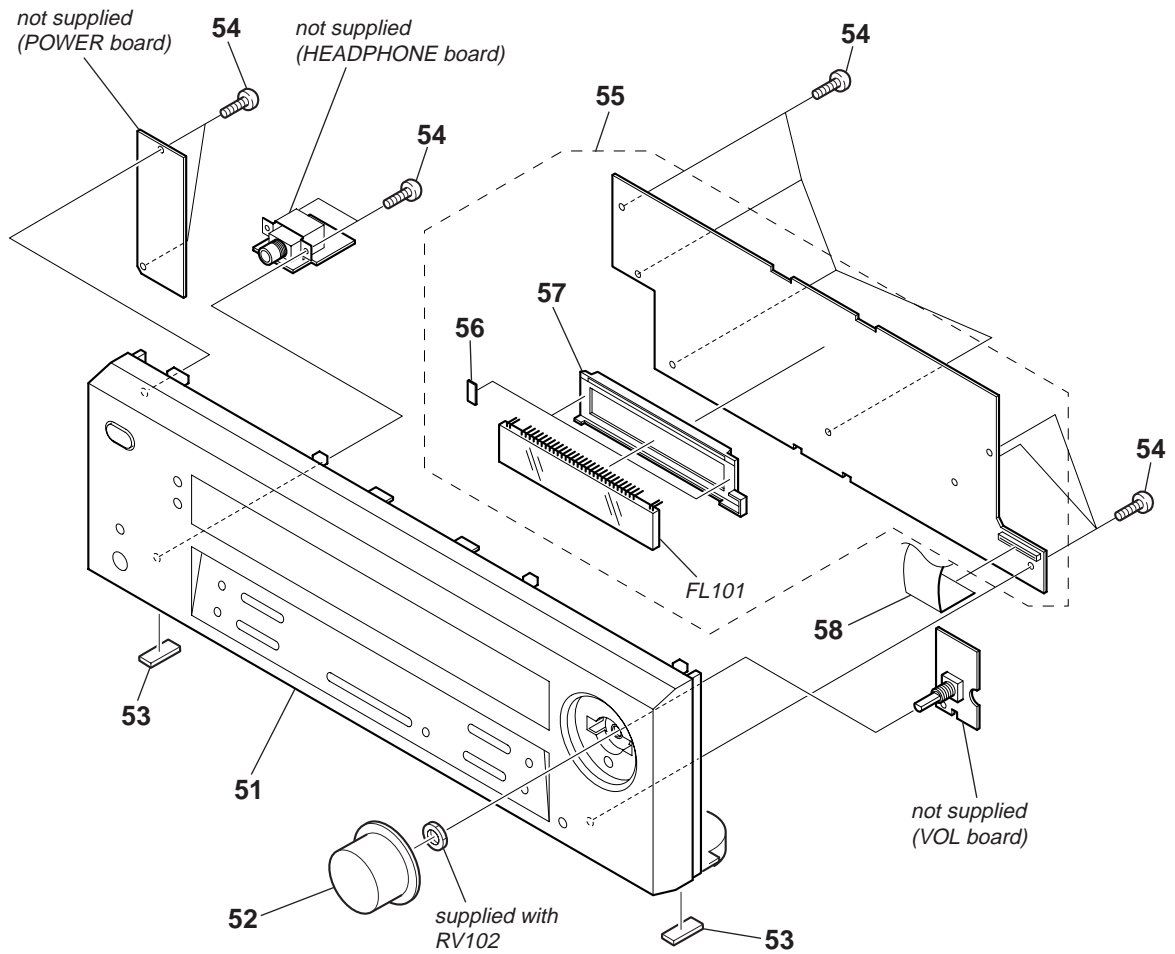

Ref. No.	Part No.	Description	Remark	Ref. No.	Part No.	Description	Remark
51	X-4955-425-1	PANEL ASSY, FRONT (BLACK)...(BLACK) (DE595:US)		52	4-232-113-01	KNOB (VOL) (BLACK)...(BLACK)	
51	X-4955-433-1	PANEL ASSY, FRONT (BLACK)...(BLACK) (DE495:AEP,UK)		52	4-232-113-12	KNOB (VOL) (SILVER)...(SILVER)	
51	X-4955-436-1	PANEL ASSY, FRONT (SILVER)...(SILVER) (DE495:AEP,UK)		52	4-232-113-22	KNOB (VOL) (GOLD)...(GOLD)	
51	X-4955-477-1	PANEL ASSY, FRONT (BLACK)...(BLACK) (DE595:CND)		53	4-977-358-01	CUSHION	
51	X-4955-478-1	PANEL ASSY, FRONT (BLACK)...(BLACK) (DE595:AUS)		54	4-951-620-01	SCREW (2.6X8), +BVTP	
51	X-4955-480-1	PANEL ASSY, FRONT (SILVER)...(SILVER) (DE595:E2,AUS,MX,AR)		55	A-4731-177-A	DISPLAY BOARD, COMPLETE (DE495)	
51	X-4955-482-1	PANEL ASSY, FRONT (GOLD)...(GOLD) (DE595:SP,MY,KR,TW)		55	A-4732-425-A	DISPLAY BOARD, COMPLETE (DE595)	
51	X-4955-489-1	PANEL ASSY, FRONT (BLACK)...(BLACK) (DE595:AEP,UK)		* 56	4-921-941-01	CUSHION (FL)	
51	X-4955-494-1	PANEL ASSY, FRONT (SILVER)...(SILVER) (DE595:AEP,UK)		* 57	3-386-245-13	HOLDER (FL)	
51	X-4955-495-1	PANEL ASSY, FRONT (GOLD)...(GOLD) (DE495:KR,SP,MY,TW)		58	1-773-154-11	WIRE (FLAT TYPE) (21 CORE)	
51	X-4955-718-1	PANEL ASSY, FRONT (BLACK)...(BLACK) (DE495:AUS)		FL101	1-518-831-11	INDICATOR TUBE, FLUORESCENT	
51	X-4955-719-1	PANEL ASSY, FRONT (SILVER)...(SILVER) (DE495:AUS)					
51	X-4955-908-1	PANEL ASSY, FRONT (SILVER)...(SILVER) (DE595:US)					

5-3. CHASSIS SECTION-1

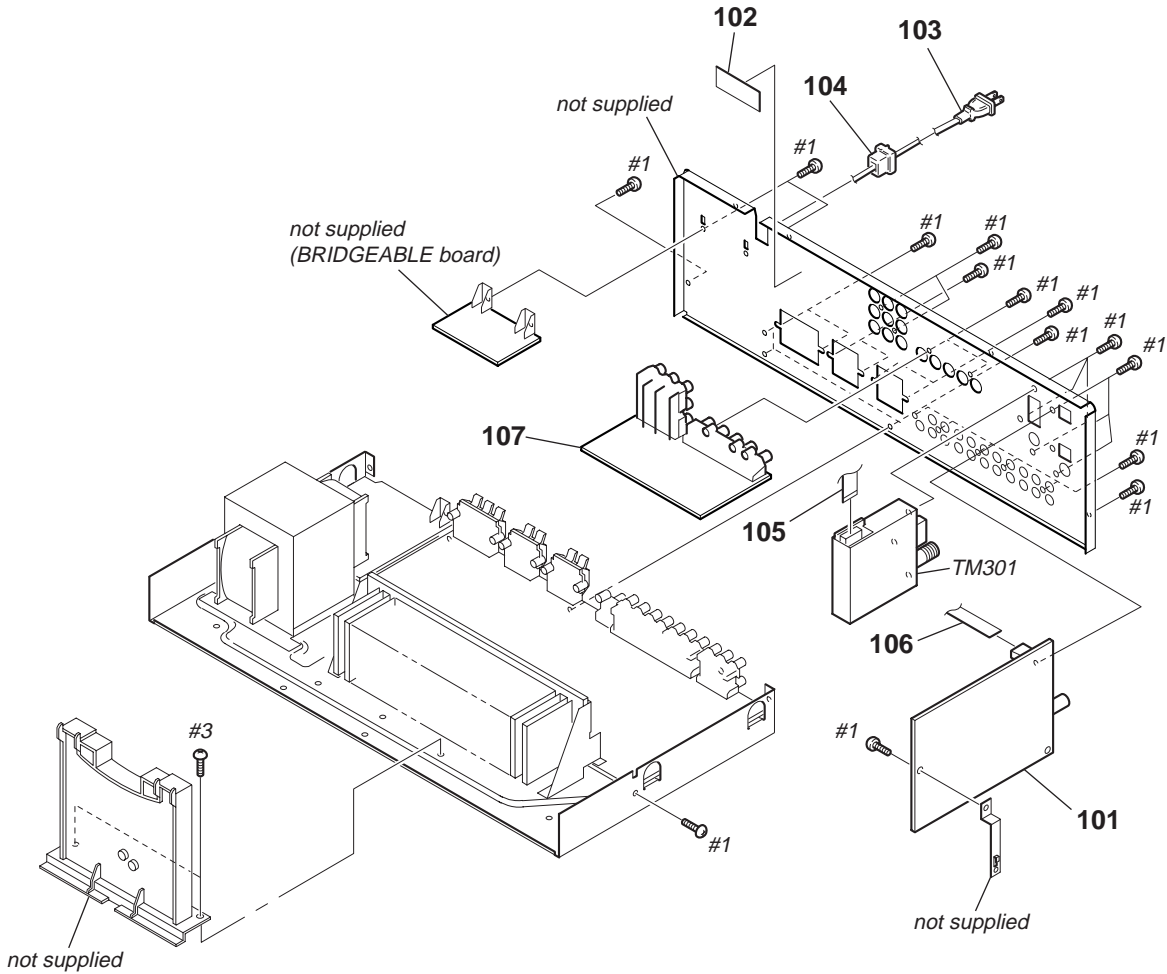

<p>The components identified by mark \triangle or dotted line with mark \triangle are critical for safety. Replace only with part number specified.</p>	<p>Les composants identifiés par une marque \triangle sont critiques pour la sécurité. Ne les remplacer que par une pièce portant le numéro spécifié.</p>
---	--

Ref. No.	Part No.	Description	Remark	Ref. No.	Part No.	Description	Remark
101	A-4732-412-A	DIGITAL BOARD, COMPLETE (DE595:US,CND)		* 104	3-703-244-00	BUSHING (2104), CORD	
101	A-4732-431-A	DIGITAL BOARD, COMPLETE (DE495:AEP,UK)		105	1-769-937-11	WIRE (FLAT TYPE) (11 CORE) (EXCEPT AEP,UK)	
101	A-4732-594-A	DIGITAL BOARD, COMPLETE (DE595:AUS)		105	1-773-001-11	WIRE (FLAT TYPE) (15 CORE) (AEP,UK)	
101	A-4732-607-A	DIGITAL BOARD, COMPLETE (DE595:SP,MY,KR)		106	1-575-662-31	WIRE (FLAT TYPE) (5 CORE)	
101	A-4732-612-A	DIGITAL BOARD, COMPLETE (DE595:E2)		107	A-4731-175-A	VIDEO BOARD, COMPLETE (DE495,DE595:AEP,UK)	
101	A-4732-615-A	DIGITAL BOARD, COMPLETE (DE595:MX,AR)		107	1-686-905-11	VIDEO BOARD (EXCEPT DE495,DE595:AEP,UK)	
101	A-4732-625-A	DIGITAL BOARD, COMPLETE (DE595:AEP,UK)		TM301	1-693-577-22	TUNER PACK (ANTENNA) (US,CND,E2,MX,AR)	
101	A-4732-631-A	DIGITAL BOARD, COMPLETE (DE495:KR,SP,MY)		TM301	1-693-578-21	TUNER PACK (ANTENNA) (AEP,UK)	
101	A-4734-333-A	DIGITAL BOARD, COMPLETE (DE595:TW)		TM301	1-693-580-22	TUNER PACK (ANTENNA) (AUS,SP,MY,KR,TW)	
101	A-4734-359-A	DIGITAL BOARD, COMPLETE (DE495:TW)		#1	7-685-646-79	SCREW +BVTP 3X8 TYPE2 IT-3	
101	A-4734-763-A	DIGITAL BOARD, COMPLETE (DE495:AUS)		#3	7-685-645-79	SCREW +BVTP 3X6 TYPE2 IT-3	
* 102	3-703-044-26	LABEL, CAUTION (US,CND)					
\triangle 103	1-696-847-11	CORD, POWER (AUS)					
\triangle 103	1-769-079-22	CORD, POWER (KR)					
\triangle 103	1-777-071-23	CORD, POWER (AEP,UK,E2,SP,MY)					
\triangle 103	1-783-532-11	CORD, POWER (US,CND,MX,TW)					
\triangle 103	1-783-941-12	CORD, POWER (AR)					

5-4. CHASSIS SECTION-2

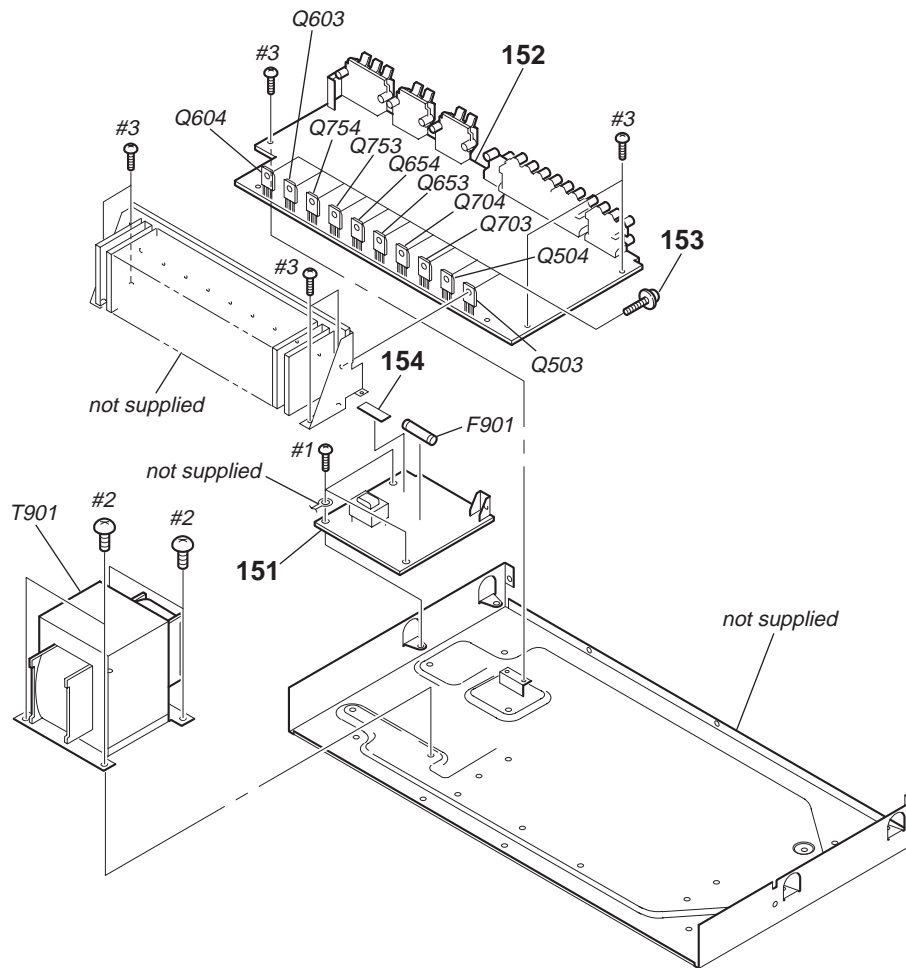

<p>The components identified by mark \triangle or dotted line with mark \triangle are critical for safety. Replace only with part number specified.</p>	<p>Les composants identifiés par une marque \triangle sont critiques pour la sécurité. Ne les remplacer que par une pièce portant le numéro spécifié.</p>
---	--

Ref. No.	Part No.	Description	Remark	Ref. No.	Part No.	Description	Remark
151	1-686-904-11	STANDBY BOARD		Q654	8-749-010-26	TRANSISTOR MP1620-OPY-M	
152	A-4731-280-A	MAIN BOARD, COMPLETE (DE495:AEP,UK,AUS,KR,TW)		Q703	8-749-010-25	TRANSISTOR MN2488-OPY-M	
152	A-4732-423-A	MAIN BOARD, COMPLETE (DE595:US,CND)		Q704	8-749-010-26	TRANSISTOR MP1620-OPY-M	
152	A-4732-595-A	MAIN BOARD, COMPLETE (DE595:AEP,UK,AUS,KR,TW)		Q753	8-749-010-25	TRANSISTOR MN2488-OPY-M	
152	A-4732-608-A	MAIN BOARD, COMPLETE (DE595:E2,MX,SP,MY,AR)		Q754	8-749-010-26	TRANSISTOR MP1620-OPY-M	
152	A-4732-632-A	MAIN BOARD, COMPLETE (DE495:SP,MY)		\triangle T901	1-437-996-11	TRANSFORMER, POWER (DE495:AEP,UK,KR,SP,MY)	
153	3-905-609-01	SCREW (TRANSISTOR)		\triangle T901	1-437-999-11	TRANSFORMER, POWER (DE495:AUS)	
154	3-701-946-27	LABEL, FUSE RATING (DE495:TW)		\triangle T901	1-439-549-11	TRANSFORMER, POWER (DE595:US,MX)	
\triangle F901	1-532-464-31	FUSE (T2.5AL/250V) (EXCEPT US,CND,MX,TW)		\triangle T901	1-439-550-11	TRANSFORMER, POWER (DE595:AEP,UK,AUS,AR,KR)	
\triangle F901	1-576-109-11	FUSE (5A/125V) (DE495:TW)		\triangle T901	1-439-551-11	TRANSFORMER, POWER (DE595:SP,MY)	
\triangle F901	1-576-193-11	FUSE (6.3A/125V) (DE595:US,CND,MX,TW)		\triangle T901	1-439-552-11	TRANSFORMER, POWER (DE595:TW)	
Q503	8-749-010-25	TRANSISTOR MN2488-OPY-M		\triangle T901	1-439-553-11	TRANSFORMER, POWER (DE595:E2)	
Q504	8-749-010-26	TRANSISTOR MP1620-OPY-M		\triangle T901	1-439-609-11	TRANSFORMER, POWER (DE595:CND)	
Q603	8-749-010-25	TRANSISTOR MN2488-OPY-M		\triangle T901	1-439-640-11	TRANSFORMER, POWER (DE495:TW)	
Q604	8-749-010-26	TRANSISTOR MP1620-OPY-M		#2	7-685-880-09	SCREW +BVTT 4X6 (S)	
Q653	8-749-010-25	TRANSISTOR MN2488-OPY-M		#3	7-685-645-79	SCREW +BVTP 3X6 TYPE2 IT-3	

NOTE:

- Due to standardization, replacements in the parts list may be different from the parts specified in the diagrams or the components used on the set.
- -XX and -X mean standardized parts, so they may have some difference from the original one.
- RESISTORS
All resistors are in ohms.
METAL: Metal-film resistor.
METAL OXIDE: Metal oxide-film resistor.
F: nonflammable
- Items marked "*" are not stocked since they are seldom required for routine service. Some delay should be anticipated when ordering these items.

- SEMICONDUCTORS
In each case, u : μ , for example:
uA.. : μ A.. uPA.. : μ PA..
uPB.. : μ PB.. uPC.. : μ PC.. uPD.. : μ PD..
- CAPACITORS
uF : μ F
- COILS
uH : μ H
- Abbreviation
CND : Canadian model
AUS : Australian model
MX : Mexican model
SP : Singapore model
E2 : AC 120 V area in E model
AR : Argentine model
KR : Korean model
TW : Taiwan model

The components identified by mark Δ or dotted line with mark Δ are critical for safety. Replace only with part number specified.

Les composants identifiés par une marque Δ sont critiques pour la sécurité. Ne les remplacer que par une pièce portant le numéro spécifié.

When indicating parts by reference number, please include the board.

Ref. No.	Part No.	Description	Remark	Ref. No.	Part No.	Description	Remark
		BRIDGEABLE BOARD (DE595)				< CAPACITOR >	

		< CONNECTOR >					
* CN906	1-564-214-11	PIN, CONNECTOR (3.96mm PITCH) 3P (DE595)		C1101	1-164-156-11	CERAMIC CHIP 0.1uF	25V
* CN908	1-564-242-00	PIN, CONNECTOR (3.96mm PITCH) 5P (DE595)		C1102	1-126-947-11	ELECT 47uF	20% 16V
CNP904	1-691-765-11	PLUG (MICRO CONNECTOR) 3P (DE595)		C1103	1-164-156-11	CERAMIC CHIP 0.1uF	25V
		< DIODE >		C1104	1-162-974-11	CERAMIC CHIP 0.01uF	50V
D818	8-719-911-19	DIODE 1SS119-25 (DE595)		C1105	1-126-947-11	ELECT 47uF	20% 16V
		< TRANSISTOR >					
Q809	8-729-119-79	TRANSISTOR 2SC2785-FEK (DE595)		C1106	1-164-156-11	CERAMIC CHIP 0.1uF	25V
		< RESISTOR >		C1107	1-162-974-11	CERAMIC CHIP 0.01uF	50V
R824	1-249-425-11	CARBON 4.7K 5% 1/4W (DE595)		C1108	1-164-156-11	CERAMIC CHIP 0.1uF	25V
R830	1-249-401-11	CARBON 47 5% 1/4W (CND)		C1109	1-162-918-11	CERAMIC CHIP 18PF	5% 50V
R830	1-249-404-81	CARBON 82 5% 1/4W (EXCEPT CND)		C1110	1-162-918-11	CERAMIC CHIP 18PF	5% 50V
R831	1-249-401-11	CARBON 47 5% 1/4W (CND)					
		< RELAY >		C1111	1-164-156-11	CERAMIC CHIP 0.1uF	25V
RY801	1-755-013-11	RELAY (EXCEPT CND)		C1112	1-162-974-11	CERAMIC CHIP 0.01uF	50V
RY802	1-755-494-11	RELAY (CND)		C1113	1-164-156-11	CERAMIC CHIP 0.1uF	25V
RY803	1-755-494-11	RELAY (CND)		C1114	1-162-905-11	CERAMIC CHIP 1PF	0.25PF 50V
		*****		C1115	1-162-923-11	CERAMIC CHIP 47PF	5% 50V
A-4732-412-A		DIGITAL BOARD, COMPLETE (DE595:US,CND)					
A-4732-431-A		DIGITAL BOARD, COMPLETE (DE495:AEP,UK)		C1116	1-126-916-11	ELECT 1000uF	20% 6.3V
A-4732-594-A		DIGITAL BOARD, COMPLETE (DE595:AUS)		C1117	1-164-156-11	CERAMIC CHIP 0.1uF	25V
A-4732-607-A		DIGITAL BOARD, COMPLETE (DE595:MY,SP,KR)		C1118	1-115-416-11	CERAMIC CHIP 0.001uF	5% 25V
A-4732-612-A		DIGITAL BOARD, COMPLETE (DE595:E2)		C1119	1-126-965-11	ELECT 22uF	20% 50V
A-4732-615-A		DIGITAL BOARD, COMPLETE (DE595:MX,AR)		C1121	1-164-156-11	CERAMIC CHIP 0.1uF	25V
A-4732-625-A		DIGITAL BOARD, COMPLETE (DE595:AEP,UK)					
A-4732-631-A		DIGITAL BOARD, COMPLETE (DE495:KR,SP,MY)		C1122	1-164-156-11	CERAMIC CHIP 0.1uF	25V (DE595)
A-4734-333-A		DIGITAL BOARD, COMPLETE (DE595:TW)		C1123	1-164-156-11	CERAMIC CHIP 0.1uF	25V
A-4734-359-A		DIGITAL BOARD, COMPLETE (DE495:TW)		C1124	1-164-156-11	CERAMIC CHIP 0.1uF	25V
A-4734-763-A		DIGITAL BOARD, COMPLETE (DE495:AUS)		C1129	1-115-416-11	CERAMIC CHIP 0.001uF	5% 25V
		*****		C1130	1-164-156-11	CERAMIC CHIP 0.1uF	25V
7-685-646-79		SCREW +BVTP 3X8 TYPE2 IT-3		C1131	1-162-927-11	CERAMIC CHIP 100PF	5% 50V

Ref. No.	Part No.	Description	Remark	Ref. No.	Part No.	Description	Remark
C1220	1-162-927-11	CERAMIC CHIP	100PF 5%	50V	C1633	1-164-156-11	CERAMIC CHIP 0.1uF 25V (AEP,UK)
C1221	1-164-156-11	CERAMIC CHIP	0.1uF	25V	C1634	1-164-156-11	CERAMIC CHIP 0.1uF 25V
C1227	1-164-156-11	CERAMIC CHIP	0.1uF	25V	C1635	1-164-156-11	CERAMIC CHIP 0.1uF 25V
C1229	1-164-156-11	CERAMIC CHIP	0.1uF	25V	C1671	1-164-156-11	CERAMIC CHIP 0.1uF 25V
C1230	1-164-156-11	CERAMIC CHIP	0.1uF	25V	C1905	1-164-156-11	CERAMIC CHIP 0.1uF 25V
C1231	1-164-156-11	CERAMIC CHIP	0.1uF	25V	C1906	1-126-935-11	ELECT 470uF 20% 16V
C1309	1-164-156-11	CERAMIC CHIP	0.1uF	25V	C1908	1-126-935-11	ELECT 470uF 20% 16V
C1310	1-164-156-11	CERAMIC CHIP	0.1uF	25V	C1909	1-164-156-11	CERAMIC CHIP 0.1uF 25V
C1311	1-164-156-11	CERAMIC CHIP	0.1uF	25V	C1910	1-126-935-11	ELECT 470uF 20% 16V
C1312	1-164-156-11	CERAMIC CHIP	0.1uF	25V	C1911	1-164-156-11	CERAMIC CHIP 0.1uF 25V
C1501	1-162-965-11	CERAMIC CHIP	0.0015uF 10%	50V	C1912	1-126-935-11	ELECT 470uF 20% 16V
C1502	1-128-131-11	ELECT	22uF 20%	50V	C1913	1-164-156-11	CERAMIC CHIP 0.1uF 25V
C1503	1-164-156-11	CERAMIC CHIP	0.1uF	25V	C1914	1-126-947-11	ELECT 47uF 20% 16V
C1504	1-126-964-11	ELECT	10uF 20%	50V	C1915	1-126-947-11	ELECT 47uF 20% 16V
C1505	1-164-156-11	CERAMIC CHIP	0.1uF	25V	C1916	1-164-156-11	CERAMIC CHIP 0.1uF 25V (AEP,UK)
C1506	1-126-935-11	ELECT	470uF 20%	16V			
C1507	1-126-964-11	ELECT	10uF 20%	50V			
C1508	1-164-156-11	CERAMIC CHIP	0.1uF	25V		< CONNECTOR >	
C1509	1-164-156-11	CERAMIC CHIP	0.1uF	25V	CNP5	1-779-978-11	PIN, CONNECTOR 3P
C1510	1-126-947-11	ELECT	47uF 20%	16V	CNP6	1-784-929-11	PIN, CONNECTOR 14P
C1511	1-164-156-11	CERAMIC CHIP	0.1uF	25V	CNS1	1-764-865-41	CONNECTOR, BOARD TO BOARD 13P
C1512	1-162-995-11	CERAMIC CHIP	0.022uF	50V	CNS2	1-784-041-41	CONNECTOR, BOARD TO BOARD 9P
C1513	1-164-156-11	CERAMIC CHIP	0.1uF	25V	CNS3	1-784-923-11	PIN, CONNECTOR 7P
C1514	1-164-156-11	CERAMIC CHIP	0.1uF	25V	CNS4	1-569-309-11	SOCKET, CONNECTOR (L TYPE) 21P
C1515	1-126-935-11	ELECT	470uF 20%	10V	CNS7	1-569-060-11	SOCKET, CONNECTOR 11P (EXCEPT AEP,UK)
C1516	1-162-967-11	CERAMIC CHIP	0.0033uF 10%	50V	CNS7	1-569-321-11	SOCKET, CONNECTOR 15P (AEP,UK)
C1517	1-162-967-11	CERAMIC CHIP	0.0033uF 10%	50V	CNS8	1-569-315-11	SOCKET, CONNECTOR 5P
C1518	1-162-967-11	CERAMIC CHIP	0.0033uF 10%	50V			
C1519	1-162-967-11	CERAMIC CHIP	0.0033uF 10%	50V		< DIODE >	
C1520	1-162-967-11	CERAMIC CHIP	0.0033uF 10%	50V	D1001	8-719-016-74	DIODE 1SS352
C1521	1-162-967-11	CERAMIC CHIP	0.0033uF 10%	50V	D1101	8-719-016-74	DIODE 1SS352
C1523	1-162-964-11	CERAMIC CHIP	0.001uF 10%	50V	D1501	8-719-049-09	DIODE 1SS367-T3SONY
C1551	1-162-965-11	CERAMIC CHIP	0.0015uF 10%	50V	D1502	8-719-049-09	DIODE 1SS367-T3SONY
C1552	1-128-131-11	ELECT	22uF 20%	50V	D1601	8-719-016-74	DIODE 1SS352
C1601	1-164-156-11	CERAMIC CHIP	0.1uF	25V			
C1602	1-164-156-11	CERAMIC CHIP	0.1uF	25V		< FERRITE BEAD >	
C1603	1-164-156-11	CERAMIC CHIP	0.1uF	25V	FB1101	1-414-813-11	FERRITE, EMI (SMD)
C1604	1-164-156-11	CERAMIC CHIP	0.1uF	25V	FB1102	1-414-813-11	FERRITE, EMI (SMD)
C1605	1-164-156-11	CERAMIC CHIP	0.1uF	25V	FB1104	1-469-152-11	FERRITE, EMI (SMD)
C1606	1-126-947-11	ELECT	47uF 20%	16V	FB1105	1-469-152-11	FERRITE, EMI (SMD)
C1607	1-164-156-11	CERAMIC CHIP	0.1uF	25V	FB1201	1-414-813-11	FERRITE, EMI (SMD)
C1610	1-162-974-11	CERAMIC CHIP	0.01uF	50V	FB1202	1-414-813-11	FERRITE, EMI (SMD)
C1611	1-162-974-11	CERAMIC CHIP	0.01uF	50V	FB1203	1-469-152-11	FERRITE, EMI (SMD)
C1612	1-164-156-11	CERAMIC CHIP	0.1uF	25V	FB1204	1-469-152-11	FERRITE, EMI (SMD)
C1613	1-162-995-11	CERAMIC CHIP	0.022uF	50V	FB1501	1-414-813-11	FERRITE, EMI (SMD)
C1614	1-162-995-11	CERAMIC CHIP	0.022uF	50V	FB1502	1-414-813-11	FERRITE, EMI (SMD)
C1615	1-162-995-11	CERAMIC CHIP	0.022uF	50V	FB1601	1-414-813-11	FERRITE, EMI (SMD)
C1616	1-162-995-11	CERAMIC CHIP	0.022uF	50V	FB1602	1-216-864-11	METAL CHIP 0 5% 1/10W
C1617	1-162-974-11	CERAMIC CHIP	0.01uF	50V	FB1603	1-216-864-11	METAL CHIP 0 5% 1/10W
C1618	1-164-156-11	CERAMIC CHIP	0.1uF	25V			
C1619	1-164-156-11	CERAMIC CHIP	0.1uF	25V		< IC >	
C1620	1-164-156-11	CERAMIC CHIP	0.1uF	25V	IC1101	8-759-825-15	IC LC89056W-E
C1624	1-164-156-11	CERAMIC CHIP	0.1uF	25V	IC1102	8-759-242-70	IC TC7WU04F
C1625	1-164-156-11	CERAMIC CHIP	0.1uF	25V	IC1105	6-600-014-01	IC TORX141L (DIGITAL VIDEO 2 IN (OPTICAL))
C1626	1-164-156-11	CERAMIC CHIP	0.1uF	25V	IC1106	6-600-014-01	IC TORX141L (DIGITAL CD/SACD IN (OPTICAL)) (DE595)
C1627	1-126-964-11	ELECT	10uF 20%	50V	IC1201	8-759-698-76	IC CXD9617R
C1632	1-164-156-11	CERAMIC CHIP	0.1uF	25V			

STR-DE495/DE595

Ver 1.1

DIGITAL

Ref. No.	Part No.	Description	Remark	Ref. No.	Part No.	Description	Remark
IC1202	8-759-538-16	IC IS61LV6416-10TT(ISSI)		R1123	1-216-809-11	METAL CHIP	100 5% 1/10W (DE595)
IC1501	6-703-705-01	IC AK4527B		R1124	1-216-809-11	METAL CHIP	100 5% 1/10W
IC1502	8-759-710-97	IC NJM4565M-D		R1202	1-216-809-11	METAL CHIP	100 5% 1/10W
IC1503	8-759-231-53	IC TA7805S		R1203	1-216-833-11	METAL CHIP	10K 5% 1/10W
IC1552	8-759-710-97	IC NJM4565M-D		R1204	1-216-821-11	METAL CHIP	1K 5% 1/10W
IC1601	6-802-541-01	IC MB9047BPF-G-138-BND		R1205	1-216-809-11	METAL CHIP	100 5% 1/10W
IC1602	6-702-913-01	IC S-80929CNMC-G8Z-T2		R1206	1-216-809-11	METAL CHIP	100 5% 1/10W
IC1604	8-759-641-86	IC BR24C16F-E2		R1207	1-216-809-11	METAL CHIP	100 5% 1/10W
IC1901	6-701-887-02	IC SI-3004KWF		R1208	1-216-809-11	METAL CHIP	100 5% 1/10W
IC1902	8-759-656-35	IC NJM7810FA		R1209	1-216-809-11	METAL CHIP	100 5% 1/10W
IC1903	8-759-450-47	IC BA05T		R1210	1-216-833-11	METAL CHIP	10K 5% 1/10W
IC1904	8-759-445-59	IC BA033T		R1212	1-216-813-11	METAL CHIP	220 5% 1/10W
IC1905	8-759-647-10	IC uPC2933HF (AEP,UK)		R1213	1-216-813-11	METAL CHIP	220 5% 1/10W
		< JACK >		R1214	1-216-813-11	METAL CHIP	220 5% 1/10W
J1101	1-794-972-11	JACK, PIN 1P (DIGITAL DVD IN (COAXIAL))		R1215	1-216-813-11	METAL CHIP	220 5% 1/10W
		< JUMPER RESISTOR >		R1216	1-216-813-11	METAL CHIP	220 5% 1/10W
JR1112	1-216-864-11	METAL CHIP	0 5% 1/10W (EXCEPT AEP,UK)	R1217	1-216-813-11	METAL CHIP	220 5% 1/10W
JR1113	1-216-864-11	METAL CHIP	0 5% 1/10W (EXCEPT AEP,UK)	R1218	1-216-813-11	METAL CHIP	220 5% 1/10W
JR1114	1-216-864-11	METAL CHIP	0 5% 1/10W (EXCEPT AEP,UK)	R1219	1-216-813-11	METAL CHIP	220 5% 1/10W
JR1115	1-216-864-11	METAL CHIP	0 5% 1/10W (DE495)	R1220	1-216-813-11	METAL CHIP	220 5% 1/10W
JR1116	1-216-864-11	METAL CHIP	0 5% 1/10W	R1221	1-216-813-11	METAL CHIP	220 5% 1/10W
JR1121	1-216-864-11	METAL CHIP	0 5% 1/10W	R1222	1-216-813-11	METAL CHIP	220 5% 1/10W
JR1122	1-216-864-11	METAL CHIP	0 5% 1/10W	R1224	1-216-813-11	METAL CHIP	220 5% 1/10W
L1901	1-216-864-11	METAL CHIP	0 5% 1/10W	R1225	1-216-813-11	METAL CHIP	220 5% 1/10W
		< TRANSISTOR >		R1226	1-216-813-11	METAL CHIP	220 5% 1/10W
Q1601	8-729-027-43	TRANSISTOR DTC114EKA-T146		R1227	1-216-813-11	METAL CHIP	220 5% 1/10W
Q1602	8-729-230-49	TRANSISTOR 2SC2712-YG		R1228	1-216-813-11	METAL CHIP	220 5% 1/10W
		< RESISTOR >		R1229	1-216-813-11	METAL CHIP	220 5% 1/10W
R1100	1-216-857-11	METAL CHIP	1M 5% 1/10W	R1230	1-216-813-11	METAL CHIP	220 5% 1/10W
R1101	1-216-833-11	METAL CHIP	10K 5% 1/10W	R1231	1-216-813-11	METAL CHIP	220 5% 1/10W
R1102	1-216-833-11	METAL CHIP	10K 5% 1/10W	R1232	1-216-813-11	METAL CHIP	220 5% 1/10W
R1103	1-216-809-11	METAL CHIP	100 5% 1/10W	R1233	1-216-813-11	METAL CHIP	220 5% 1/10W
R1104	1-216-809-11	METAL CHIP	100 5% 1/10W	R1234	1-216-813-11	METAL CHIP	220 5% 1/10W
R1105	1-216-829-11	METAL CHIP	4.7K 5% 1/10W	R1235	1-216-813-11	METAL CHIP	220 5% 1/10W
R1106	1-216-839-11	METAL CHIP	33K 5% 1/10W	R1236	1-216-813-11	METAL CHIP	220 5% 1/10W
R1107	1-216-830-11	METAL CHIP	5.6K 5% 1/10W	R1237	1-216-813-11	METAL CHIP	220 5% 1/10W
R1108	1-216-809-11	METAL CHIP	100 5% 1/10W	R1238	1-216-813-11	METAL CHIP	220 5% 1/10W
R1109	1-216-809-11	METAL CHIP	100 5% 1/10W	R1239	1-216-813-11	METAL CHIP	220 5% 1/10W
R1110	1-216-821-11	METAL CHIP	1K 5% 1/10W	R1240	1-216-813-11	METAL CHIP	220 5% 1/10W
R1111	1-216-821-11	METAL CHIP	1K 5% 1/10W	R1241	1-216-813-11	METAL CHIP	220 5% 1/10W
R1112	1-216-809-11	METAL CHIP	100 5% 1/10W	R1242	1-216-813-11	METAL CHIP	220 5% 1/10W
R1113	1-216-821-11	METAL CHIP	1K 5% 1/10W	R1243	1-216-813-11	METAL CHIP	220 5% 1/10W
R1114	1-216-809-11	METAL CHIP	100 5% 1/10W	R1244	1-216-813-11	METAL CHIP	220 5% 1/10W
R1115	1-216-833-11	METAL CHIP	10K 5% 1/10W	R1304	1-216-841-11	METAL CHIP	47K 5% 1/10W
R1116	1-218-285-11	METAL CHIP	75 5% 1/10W	R1305	1-216-841-11	METAL CHIP	47K 5% 1/10W
R1117	1-216-821-11	METAL CHIP	1K 5% 1/10W	R1308	1-216-809-11	METAL CHIP	100 5% 1/10W
R1118	1-216-854-11	METAL CHIP	560K 5% 1/10W	R1314	1-216-864-11	METAL CHIP	0 5% 1/10W
R1119	1-216-837-11	METAL CHIP	22K 5% 1/10W	R1364	1-216-864-11	METAL CHIP	0 5% 1/10W
R1121	1-216-809-11	METAL CHIP	100 5% 1/10W	R1501	1-216-815-11	METAL CHIP	330 5% 1/10W
				R1502	1-216-833-11	METAL CHIP	10K 5% 1/10W
				R1503	1-216-833-11	METAL CHIP	10K 5% 1/10W
				R1504	1-216-815-11	METAL CHIP	330 5% 1/10W
				R1505	1-216-830-11	METAL CHIP	5.6K 5% 1/10W
				R1506	1-216-837-11	METAL CHIP	22K 5% 1/10W
				R1507	1-216-829-11	METAL CHIP	4.7K 5% 1/10W
				R1508	1-216-845-11	METAL CHIP	100K 5% 1/10W
				R1509	1-216-821-11	METAL CHIP	1K 5% 1/10W

Ref. No.	Part No.	Description	Remark	Ref. No.	Part No.	Description	Remark
R1516	1-216-813-11	METAL CHIP	220 5% 1/10W	R1633	1-216-837-11	METAL CHIP	22K 5% 1/10W
R1517	1-216-813-11	METAL CHIP	220 5% 1/10W				(MX,AR)
R1518	1-216-813-11	METAL CHIP	220 5% 1/10W	R1633	1-216-841-11	METAL CHIP	47K 5% 1/10W
R1519	1-216-813-11	METAL CHIP	220 5% 1/10W				(AEP,UK,E2,SP,MY,KR,TW)
R1520	1-216-813-11	METAL CHIP	220 5% 1/10W	R1635	1-216-833-11	METAL CHIP	10K 5% 1/10W
				R1636	1-216-833-11	METAL CHIP	10K 5% 1/10W
R1521	1-216-813-11	METAL CHIP	220 5% 1/10W	R1637	1-216-833-11	METAL CHIP	10K 5% 1/10W
R1551	1-216-815-11	METAL CHIP	330 5% 1/10W				
R1552	1-216-833-11	METAL CHIP	10K 5% 1/10W	R1638	1-216-829-11	METAL CHIP	4.7K 5% 1/10W
R1553	1-216-833-11	METAL CHIP	10K 5% 1/10W	R1639	1-216-809-11	METAL CHIP	100 5% 1/10W
R1554	1-216-815-11	METAL CHIP	330 5% 1/10W	R1640	1-216-809-11	METAL CHIP	100 5% 1/10W
				R1641	1-216-809-11	METAL CHIP	100 5% 1/10W
R1555	1-216-830-11	METAL CHIP	5.6K 5% 1/10W	R1642	1-216-833-11	METAL CHIP	10K 5% 1/10W
R1556	1-216-837-11	METAL CHIP	22K 5% 1/10W				
R1557	1-216-829-11	METAL CHIP	4.7K 5% 1/10W	R1643	1-216-821-11	METAL CHIP	1K 5% 1/10W
R1600	1-216-829-11	METAL CHIP	4.7K 5% 1/10W	R1644	1-216-821-11	METAL CHIP	1K 5% 1/10W
R1601	1-216-821-11	METAL CHIP	1K 5% 1/10W	R1645	1-216-821-11	METAL CHIP	1K 5% 1/10W
				R1646	1-216-821-11	METAL CHIP	1K 5% 1/10W
R1602	1-216-829-11	METAL CHIP	4.7K 5% 1/10W	R1647	1-216-821-11	METAL CHIP	1K 5% 1/10W
R1603	1-216-821-11	METAL CHIP	1K 5% 1/10W				
R1604	1-216-809-11	METAL CHIP	100 5% 1/10W	R1648	1-216-821-11	METAL CHIP	1K 5% 1/10W
R1605	1-216-809-11	METAL CHIP	100 5% 1/10W	R1649	1-216-821-11	METAL CHIP	1K 5% 1/10W
R1606	1-216-821-11	METAL CHIP	1K 5% 1/10W	R1650	1-216-833-11	METAL CHIP	10K 5% 1/10W
				R1651	1-216-833-11	METAL CHIP	10K 5% 1/10W
R1607	1-216-821-11	METAL CHIP	1K 5% 1/10W	R1654	1-216-833-11	METAL CHIP	10K 5% 1/10W
R1608	1-216-821-11	METAL CHIP	1K 5% 1/10W				
R1609	1-216-821-11	METAL CHIP	1K 5% 1/10W	R1655	1-216-833-11	METAL CHIP	10K 5% 1/10W
R1610	1-216-821-11	METAL CHIP	1K 5% 1/10W	R1656	1-216-841-11	METAL CHIP	47K 5% 1/10W
R1611	1-216-821-11	METAL CHIP	1K 5% 1/10W	R1657	1-216-833-11	METAL CHIP	10K 5% 1/10W
				R1658	1-216-809-11	METAL CHIP	100 5% 1/10W
R1612	1-216-821-11	METAL CHIP	1K 5% 1/10W	R1659	1-216-833-11	METAL CHIP	10K 5% 1/10W
R1613	1-216-821-11	METAL CHIP	1K 5% 1/10W				
R1614	1-216-821-11	METAL CHIP	1K 5% 1/10W	R1660	1-216-833-11	METAL CHIP	10K 5% 1/10W
R1615	1-216-821-11	METAL CHIP	1K 5% 1/10W	R1662	1-216-827-11	METAL CHIP	3.3K 5% 1/10W
R1616	1-216-821-11	METAL CHIP	1K 5% 1/10W	R1663	1-216-827-11	METAL CHIP	3.3K 5% 1/10W
				R1664	1-216-809-11	METAL CHIP	100 5% 1/10W
				R1665	1-216-809-11	METAL CHIP	100 5% 1/10W
R1617	1-216-809-11	METAL CHIP	100 5% 1/10W	R1666	1-216-821-11	METAL CHIP	1K 5% 1/10W
R1618	1-216-809-11	METAL CHIP	100 5% 1/10W				(DE595)
R1619	1-216-809-11	METAL CHIP	100 5% 1/10W	R1666	1-216-864-11	METAL CHIP	0 5% 1/10W
R1621	1-216-821-11	METAL CHIP	1K 5% 1/10W				(DE495)
R1622	1-216-833-11	METAL CHIP	10K 5% 1/10W	R1667	1-216-821-11	METAL CHIP	1K 5% 1/10W
				R1668	1-216-833-11	METAL CHIP	10K 5% 1/10W
							(DE495)
R1623	1-216-829-11	METAL CHIP	4.7K 5% 1/10W	R1669	1-216-833-11	METAL CHIP	10K 5% 1/10W
R1624	1-216-833-11	METAL CHIP	10K 5% 1/10W	R1670	1-216-833-11	METAL CHIP	10K 5% 1/10W
R1625	1-216-833-11	METAL CHIP	10K 5% 1/10W	R1671	1-216-825-11	METAL CHIP	2.2K 5% 1/10W
R1626	1-216-833-11	METAL CHIP	10K 5% 1/10W				(DE495)
R1627	1-216-833-11	METAL CHIP	10K 5% 1/10W	R1671	1-216-864-11	METAL CHIP	0 5% 1/10W
							(DE595)
R1628	1-216-833-11	METAL CHIP	10K 5% 1/10W	R1672	1-216-841-11	METAL CHIP	47K 5% 1/10W
R1629	1-216-833-11	METAL CHIP	10K 5% 1/10W				(DE495)
R1630	1-216-833-11	METAL CHIP	10K 5% 1/10W	R1673	1-216-809-11	METAL CHIP	100 5% 1/10W
R1631	1-216-829-11	METAL CHIP	4.7K 5% 1/10W				
R1632	1-216-825-11	METAL CHIP	2.2K 5% 1/10W	R1674	1-216-809-11	METAL CHIP	100 5% 1/10W
				R1676	1-216-821-11	METAL CHIP	1K 5% 1/10W
				R1677	1-216-821-11	METAL CHIP	1K 5% 1/10W
R1632	1-216-829-11	METAL CHIP	4.7K 5% 1/10W	R1678	1-216-821-11	METAL CHIP	1K 5% 1/10W
				R1679	1-216-821-11	METAL CHIP	1K 5% 1/10W
R1632	1-216-841-11	METAL CHIP	47K 5% 1/10W	R1681	1-216-833-11	METAL CHIP	10K 5% 1/10W
							(DE495)
R1632	1-216-864-11	METAL CHIP	0 5% 1/10W	R1682	1-216-845-11	METAL CHIP	100K 5% 1/10W
				R1683	1-216-833-11	METAL CHIP	10K 5% 1/10W
				R1684	1-216-833-11	METAL CHIP	10K 5% 1/10W
R1633	1-216-833-11	METAL CHIP	10K 5% 1/10W	R1685	1-216-833-11	METAL CHIP	10K 5% 1/10W
							(AUS)

STR-DE495/DE595

Ver 1.1

DIGITAL **DISPLAY**

Ref. No.	Part No.	Description	Remark
R1686	1-216-833-11	METAL CHIP	10K 5% 1/10W
R1687	1-216-833-11	METAL CHIP	10K 5% 1/10W
R1688	1-216-864-11	METAL CHIP	0 5% 1/10W
R1689	1-216-833-11	METAL CHIP	10K 5% 1/10W
R1690	1-216-833-11	METAL CHIP	10K 5% 1/10W
R1694	1-216-821-11	METAL CHIP	1K 5% 1/10W
R1698	1-216-829-11	METAL CHIP	4.7K 5% 1/10W
R1699	1-216-829-11	METAL CHIP	4.7K 5% 1/10W
R1703	1-216-833-11	METAL CHIP	10K 5% 1/10W
R1704	1-216-833-11	METAL CHIP	10K 5% 1/10W
R1705	1-216-809-11	METAL CHIP	100 5% 1/10W (AEP,UK)
R1706	1-216-833-11	METAL CHIP	10K 5% 1/10W
R1707	1-216-833-11	METAL CHIP	10K 5% 1/10W
R1708	1-216-833-11	METAL CHIP	10K 5% 1/10W
R1709	1-216-833-11	METAL CHIP	10K 5% 1/10W
R1710	1-216-809-11	METAL CHIP	100 5% 1/10W (AEP,UK)
R1711	1-216-809-11	METAL CHIP	100 5% 1/10W (AEP,UK)
< VIBRATOR >			
X1101	1-795-126-21	VIBRATOR, CRYSTAL (12.288MHz)	
X1201	1-795-297-21	VIBRATOR, CERAMIC (13.59MHz)	
X1601	1-781-356-21	VIBRATOR, CERAMIC (16MHz)	

A-4731-177-A	DISPLAY BOARD, COMPLETE (DE495)		
A-4732-425-A	DISPLAY BOARD, COMPLETE (DE595)		

* 3-386-245-13	HOLDER (FL)		
* 4-921-941-01	CUSHION (FL)		
< CAPACITOR >			
C100	1-164-159-11	CERAMIC	0.1uF 50V
C101	1-164-159-11	CERAMIC	0.1uF 50V
C104	1-164-159-11	CERAMIC	0.1uF 50V (DE595)
C105	1-126-795-11	ELECT	10uF 20% 50V
C108	1-164-159-11	CERAMIC	0.1uF 50V
C109	1-164-159-11	CERAMIC	0.1uF 50V
C110	1-128-821-11	CERAMIC	0.001uF 5% 50V
C111	1-128-813-11	CERAMIC	220PF 5% 50V
C112	1-128-813-11	CERAMIC	220PF 5% 50V
C114	1-164-159-11	CERAMIC	0.1uF 50V
C115	1-126-795-11	ELECT	10uF 20% 50V
C132	1-128-813-11	CERAMIC	220PF 5% 50V
C133	1-128-813-11	CERAMIC	220PF 5% 50V
C134	1-128-813-11	CERAMIC	220PF 5% 50V
C135	1-128-813-11	CERAMIC	220PF 5% 50V
C136	1-128-813-11	CERAMIC	220PF 5% 50V
C137	1-128-813-11	CERAMIC	220PF 5% 50V
C138	1-128-813-11	CERAMIC	220PF 5% 50V
C139	1-128-813-11	CERAMIC	220PF 5% 50V
C140	1-128-813-11	CERAMIC	220PF 5% 50V
C141	1-128-813-11	CERAMIC	220PF 5% 50V
C142	1-128-813-11	CERAMIC	220PF 5% 50V
C143	1-128-813-11	CERAMIC	220PF 5% 50V
C144	1-164-159-11	CERAMIC	0.1uF 50V

Ref. No.	Part No.	Description	Remark
C150	1-164-159-11	CERAMIC	0.1uF 50V
C151	1-126-795-11	ELECT	10uF 20% 50V
C152	1-128-813-11	CERAMIC	220PF 5% 50V
C153	1-128-813-11	CERAMIC	220PF 5% 50V
C154	1-128-813-11	CERAMIC	220PF 5% 50V
C155	1-164-159-11	CERAMIC	0.1uF 50V
C156	1-164-159-11	CERAMIC	0.1uF 50V
C157	1-164-159-11	CERAMIC	0.1uF 50V
< CONNECTOR >			
CNS100	1-569-324-11	SOCKET, CONNECTOR 21P	
< DIODE >			
D101	8-719-084-07	LED SEL5E20C-TP15 (MULTI CHANNEL DECODING) (DE595)	
D102	8-719-046-39	LED SEL5821A-TP15 (MUSIC)	
D103	8-719-046-39	LED SEL5821A-TP15 (MOVIE)	
D104	8-719-046-39	LED SEL5821A-TP15 (A.F.D.)	
D105	8-719-046-39	LED SEL5821A-TP15 (2CH)	
< FLUORESCENT INDICATOR >			
FL101	1-518-831-11	INDICATOR TUBE, FLUORESCENT	
< IC >			
IC100	8-759-643-83	IC uPD16315GB-3BS	
IC101	8-759-036-90	IC MC74ACT08N	
IC102	6-600-055-01	IC GP1UD27SXK (R)	
< COIL >			
L101	1-412-473-21	INDUCTOR (SMALL TYPE)	
L102	1-410-525-11	INDUCTOR 220uH	
< TRANSISTOR >			
Q100	8-729-119-78	TRANSISTOR 2SC2785-HFE (DE595)	
< RESISTOR >			
R101	1-249-417-11	CARBON	1K 5% 1/4W
R102	1-249-421-11	CARBON	2.2K 5% 1/4W
R103	1-249-421-11	CARBON	2.2K 5% 1/4W
R104	1-249-425-11	CARBON	4.7K 5% 1/4W
R105	1-249-429-11	CARBON	10K 5% 1/4W
R106	1-249-433-11	CARBON	22K 5% 1/4W
R111	1-249-417-11	CARBON	1K 5% 1/4W
R112	1-249-421-11	CARBON	2.2K 5% 1/4W
R113	1-249-421-11	CARBON	2.2K 5% 1/4W
R114	1-249-425-11	CARBON	4.7K 5% 1/4W
R115	1-249-429-11	CARBON	10K 5% 1/4W
R116	1-249-433-11	CARBON	22K 5% 1/4W (DE595)
R121	1-249-417-11	CARBON	1K 5% 1/4W
R122	1-249-421-11	CARBON	2.2K 5% 1/4W
R123	1-249-421-11	CARBON	2.2K 5% 1/4W
R124	1-249-425-11	CARBON	4.7K 5% 1/4W
R125	1-249-429-11	CARBON	10K 5% 1/4W
R131	1-249-417-11	CARBON	1K 5% 1/4W
R132	1-249-421-11	CARBON	2.2K 5% 1/4W
R133	1-249-421-11	CARBON	2.2K 5% 1/4W

DISPLAY

HEADPHONE

MAIN

Ref. No.	Part No.	Description	Remark	Ref. No.	Part No.	Description	Remark
R134	1-249-425-11	CARBON	4.7K 5%	1/4W		< JACK >	
R135	1-249-429-11	CARBON	10K 5%	1/4W			
R136	1-249-433-11	CARBON	22K 5%	1/4W	J791	1-815-313-21	JACK (PHONES) (SP,MY,KR,TW)
					J791	1-815-314-21	JACK (PHONES) (EXCEPT SP,MY,KR,TW)
R141	1-249-421-11	CARBON	2.2K 5%	1/4W (DE595)	*****		
R150	1-249-440-11	CARBON	82K 5%	1/4W	A-4731-280-A	MAIN BOARD, COMPLETE (DE495: AEP,UK,AUS,KR,TW)	
R153	1-247-807-31	CARBON	100 5%	1/4W	A-4732-423-A	MAIN BOARD, COMPLETE (DE595:US,CND)	
R154	1-249-393-11	CARBON	10 5%	1/4W	A-4732-595-A	MAIN BOARD, COMPLETE (DE595: AEP,UK,AUS,KR,TW)	
R155	1-249-441-11	CARBON	100K 5%	1/4W	A-4732-608-A	MAIN BOARD, COMPLETE (DE595: E2,MX,SP,MY,AR)	
R160	1-249-402-11	CARBON	56 5%	1/4W (DE595)	A-4732-632-A	MAIN BOARD, COMPLETE (DE495:SP,MY) *****	
R161	1-249-409-11	CARBON	220 5%	1/4W			
R162	1-249-429-11	CARBON	10K 5%	1/4W (DE595)	7-685-646-79	SCREW +BVTP 3X8 TYPE2 IT-3	
R175	1-249-393-11	CARBON	10 5%	1/4W		< CAPACITOR >	
R198	1-249-381-11	CARBON	1 5%	1/4W			
R199	1-249-381-11	CARBON	1 5%	1/4W			
		< SWITCH >					
S100	1-771-410-21	SWITCH, TACTILE (MENU <)			C371	1-127-880-11	CERAMIC 0.022uF 10% 50V
S101	1-771-410-21	SWITCH, TACTILE (MENU >)			C372	1-127-880-11	CERAMIC 0.022uF 10% 50V
S102	1-771-410-21	SWITCH, TACTILE (MAIN MENU)			C373	1-127-880-11	CERAMIC 0.022uF 10% 50V
S103	1-771-410-21	SWITCH, TACTILE (ENTER)			C374	1-164-159-11	CERAMIC 0.1uF 50V
S104	1-771-410-21	SWITCH, TACTILE (INPUT MODE)			C375	1-127-880-11	CERAMIC 0.022uF 10% 50V
S105	1-771-410-21	SWITCH, TACTILE (MENU -)			C376	1-127-880-11	CERAMIC 0.022uF 10% 50V
S106	1-771-410-21	SWITCH, TACTILE (MENU +)			C400	1-164-159-11	CERAMIC 0.1uF 50V
S110	1-771-410-21	SWITCH, TACTILE (TUNER FM/AM)			C402	1-126-961-11	ELECT 2.2uF 20% 50V
S111	1-771-410-21	SWITCH, TACTILE (CD) (DE495)			C404	1-126-961-11	ELECT 2.2uF 20% 50V
S111	1-771-410-21	SWITCH, TACTILE (CD/SACD) (DE595)			C405	1-126-961-11	ELECT 2.2uF 20% 50V
S112	1-771-410-21	SWITCH, TACTILE (MD/TAPE)			C406	1-126-963-11	ELECT 4.7uF 20% 50V
S113	1-771-410-21	SWITCH, TACTILE (DVD)			C407	1-126-961-11	ELECT 2.2uF 20% 50V
S114	1-771-410-21	SWITCH, TACTILE (MOVIE)			C408	1-126-963-11	ELECT 4.7uF 20% 50V
S115	1-771-410-21	SWITCH, TACTILE (MUSIC)			C409	1-126-963-11	ELECT 4.7uF 20% 50V
S116	1-771-410-21	SWITCH, TACTILE (MULTI CH IN) (DE595)			C411	1-126-961-11	ELECT 2.2uF 20% 50V (DE595)
S120	1-771-410-21	SWITCH, TACTILE (A.F.D.)			C412	1-126-961-11	ELECT 2.2uF 20% 50V (DE595)
S121	1-771-410-21	SWITCH, TACTILE (TUNING -)			C413	1-124-257-00	ELECT 2.2uF 20% 50V
S122	1-771-410-21	SWITCH, TACTILE (FM MODE)			C414	1-124-257-00	ELECT 2.2uF 20% 50V
S123	1-771-410-21	SWITCH, TACTILE (TUNING +)			C415	1-124-257-00	ELECT 2.2uF 20% 50V
S124	1-771-410-21	SWITCH, TACTILE (2CH)			C416	1-126-961-11	ELECT 2.2uF 20% 50V
S125	1-771-410-21	SWITCH, TACTILE (PRESET TUNING +)			C417	1-124-257-00	ELECT 2.2uF 20% 50V
S130	1-771-410-21	SWITCH, TACTILE (VIDEO 2)			C418	1-126-961-11	ELECT 2.2uF 20% 50V
S131	1-771-410-21	SWITCH, TACTILE (VIDEO 1)			C419	1-124-257-00	ELECT 2.2uF 20% 50V
S132	1-771-410-21	SWITCH, TACTILE (PRESET TUNING -)			C431	1-126-961-11	ELECT 2.2uF 20% 50V (DE595)
S133	1-771-410-21	SWITCH, TACTILE (MEMORY)			C432	1-126-961-11	ELECT 2.2uF 20% 50V (DE595)
S134	1-771-410-21	SWITCH, TACTILE (DISPLAY)					
S135	1-771-410-21	SWITCH, TACTILE (DIMMER)			C433	1-126-961-11	ELECT 2.2uF 20% 50V
*****					C452	1-126-961-11	ELECT 2.2uF 20% 50V
*****					C454	1-126-961-11	ELECT 2.2uF 20% 50V
*****					C455	1-126-961-11	ELECT 2.2uF 20% 50V
*****					C456	1-126-963-11	ELECT 4.7uF 20% 50V
*****					C457	1-126-961-11	ELECT 2.2uF 20% 50V
*****					C458	1-126-963-11	ELECT 4.7uF 20% 50V
*****					C459	1-126-963-11	ELECT 4.7uF 20% 50V
*****					C461	1-126-961-11	ELECT 2.2uF 20% 50V (DE595)
*****					C462	1-126-961-11	ELECT 2.2uF 20% 50V (DE595)
C790	1-164-159-11	CERAMIC	0.1uF	50V			
C792	1-164-159-11	CERAMIC	0.1uF	50V			
		< CONNECTOR >					
CNP791	1-691-767-11	PLUG (MICRO CONNECTOR) 5P			C464	1-164-159-11	CERAMIC 0.1uF 50V

STR-DE495/DE595

Ver 1.1

MAIN

Ref. No.	Part No.	Description	Remark	Ref. No.	Part No.	Description	Remark
C465	1-126-934-11	ELECT	220uF 20% 16V	C657	1-128-809-11	CERAMIC	100PF 5% 50V
C466	1-126-934-11	ELECT	220uF 20% 16V	C660	1-126-947-11	ELECT	47uF 20% 25V
C467	1-164-159-11	CERAMIC	0.1uF 50V	C661	1-136-157-00	FILM	0.022uF 5% 50V
C471	1-126-963-11	ELECT	4.7uF 20% 50V	C666	1-162-815-11	CERAMIC	47PF 5% 500V
C472	1-126-963-11	ELECT	4.7uF 20% 50V	C669	1-162-815-11	CERAMIC	47PF 5% 500V
C481	1-126-963-11	ELECT	4.7uF 20% 50V	C670	1-128-813-11	CERAMIC	220PF 5% 50V
C482	1-126-963-11	ELECT	4.7uF 20% 50V	C680	1-126-964-11	ELECT	10uF 20% 50V
C483	1-126-963-11	ELECT	4.7uF 20% 50V	C681	1-127-876-11	CERAMIC	0.01uF 10% 50V
C484	1-126-963-11	ELECT	4.7uF 20% 50V	C691	1-164-159-11	CERAMIC	0.1uF 50V
C485	1-126-963-11	ELECT	4.7uF 20% 50V	C700	1-128-825-11	CERAMIC	0.0022uF 5% 50V
C486	1-126-963-11	ELECT	4.7uF 20% 50V	C701	1-126-963-11	ELECT	4.7uF 20% 50V
C487	1-126-964-11	ELECT	10uF 20% 50V	C703	1-104-665-11	ELECT	100uF 20% 10V
C488	1-164-159-11	CERAMIC	0.1uF 50V	C704	1-107-583-11	CERAMIC	3PF 0.25PF 500V
C489	1-128-809-11	CERAMIC	100PF 5% 50V	C705	1-102-233-00	CERAMIC	33PF 10% 500V
C490	1-128-809-11	CERAMIC	100PF 5% 50V	C706	1-128-813-11	CERAMIC	220PF 5% 50V
C491	1-126-963-11	ELECT	4.7uF 20% 50V	C707	1-128-809-11	CERAMIC	100PF 5% 50V
C492	1-126-963-11	ELECT	4.7uF 20% 50V	C710	1-126-947-11	ELECT	47uF 20% 25V
C493	1-126-963-11	ELECT	4.7uF 20% 50V	C711	1-136-157-00	FILM	0.022uF 5% 50V
C494	1-126-963-11	ELECT	4.7uF 20% 50V	C716	1-162-815-11	CERAMIC	47PF 5% 500V
C495	1-126-963-11	ELECT	4.7uF 20% 50V	C717	1-162-815-11	CERAMIC	47PF 5% 500V
C496	1-126-963-11	ELECT	4.7uF 20% 50V	C720	1-128-813-11	CERAMIC	220PF 5% 50V
C497	1-128-809-11	CERAMIC	100PF 5% 50V	C721	1-126-934-11	ELECT	220uF 20% 16V
C498	1-128-803-11	CERAMIC	33PF 5% 50V	C722	1-126-964-11	ELECT	10uF 20% 50V
C500	1-128-825-11	CERAMIC	0.0022uF 5% 50V	C732	1-128-582-11	ELECT	10uF 20% 100V
C501	1-126-963-11	ELECT	4.7uF 20% 50V	C733	1-128-582-11	ELECT	10uF 20% 100V
C503	1-104-665-11	ELECT	100uF 20% 10V	C740	1-126-964-11	ELECT	10uF 20% 50V
C504	1-107-583-11	CERAMIC	3PF 0.25PF 500V	C741	1-128-579-11	ELECT	2.2uF 20% 100V
C505	1-101-810-00	CERAMIC	100PF 5% 500V	C742	1-127-876-11	CERAMIC	0.01uF 10% 50V
C506	1-101-810-00	CERAMIC	100PF 5% 500V	C750	1-126-964-11	ELECT	10uF 20% 50V
C507	1-128-809-11	CERAMIC	100PF 5% 50V	C751	1-126-963-11	ELECT	4.7uF 20% 50V
C508	1-128-809-11	CERAMIC	100PF 5% 50V	C752	1-127-876-11	CERAMIC	0.01uF 10% 50V
C510	1-126-947-11	ELECT	47uF 20% 25V	C753	1-104-665-11	ELECT	100uF 20% 10V
C511	1-136-157-00	FILM	0.022uF 5% 50V	C754	1-107-583-11	CERAMIC	3PF 0.25PF 500V
C516	1-162-815-11	CERAMIC	47PF 5% 500V	C755	1-102-233-00	CERAMIC	33PF 10% 500V
C517	1-162-815-11	CERAMIC	47PF 5% 500V	C756	1-128-813-11	CERAMIC	220PF 5% 50V
C519	1-128-813-11	CERAMIC	220PF 5% 50V	C757	1-128-809-11	CERAMIC	100PF 5% 50V
C540	1-126-964-11	ELECT	10uF 20% 50V	C760	1-126-947-11	ELECT	47uF 20% 25V
C541	1-127-876-11	CERAMIC	0.01uF 10% 50V	C761	1-136-157-00	FILM	0.022uF 5% 50V
C601	1-126-963-11	ELECT	4.7uF 20% 50V	C766	1-162-815-11	CERAMIC	47PF 5% 500V
C603	1-104-665-11	ELECT	100uF 20% 10V	C767	1-162-815-11	CERAMIC	47PF 5% 500V
C604	1-107-583-11	CERAMIC	3PF 0.25PF 500V	C770	1-128-813-11	CERAMIC	220PF 5% 50V
C605	1-102-233-00	CERAMIC	33PF 10% 500V	C800	1-128-825-11	CERAMIC	0.0022uF 5% 50V
C606	1-128-813-11	CERAMIC	220PF 5% 50V				(DE595)
C607	1-128-809-11	CERAMIC	100PF 5% 50V	C801	1-126-947-11	ELECT	47uF 20% 35V
C610	1-126-947-11	ELECT	47uF 20% 25V	C802	1-126-947-11	ELECT	47uF 20% 35V
C611	1-136-157-00	FILM	0.022uF 5% 50V	C803	1-165-498-11	ELECT	4700uF 20% 63V
C616	1-106-355-12	FILM	0.0033uF 5% 100V				(DE495)
C617	1-106-355-12	FILM	0.0033uF 5% 100V	C803	1-165-946-11	ELECT	6800uF 20% 71V
C619	1-128-813-11	CERAMIC	220PF 5% 50V				(DE595:US,CND,E2,MX,SP,MY,AR)
C620	1-162-815-11	CERAMIC	47PF 5% 500V	C803	1-165-960-11	ELECT	6800uF 20% 71V
C621	1-162-815-11	CERAMIC	47PF 5% 500V				(DE595:AEP,UK,AUS,KR,TW)
C640	1-126-964-11	ELECT	10uF 20% 50V	C804	1-165-498-11	ELECT	4700uF 20% 63V
C642	1-127-876-11	CERAMIC	0.01uF 10% 50V				(DE495)
C651	1-126-963-11	ELECT	4.7uF 20% 50V	C804	1-165-946-11	ELECT	6800uF 20% 71V
C653	1-104-665-11	ELECT	100uF 20% 10V				(DE595:US,CND,E2,MX,SP,MY,AR)
C654	1-107-583-11	CERAMIC	3PF 0.25PF 500V	C804	1-165-960-11	ELECT	6800uF 20% 71V
C655	1-102-233-00	CERAMIC	33PF 10% 500V				(DE595:AEP,UK,AUS,KR,TW)
C656	1-128-813-11	CERAMIC	220PF 5% 50V	C805	1-135-851-21	MYLAR	0.22uF 100V
				C806	1-135-851-21	MYLAR	0.22uF 100V

Ref. No.	Part No.	Description	Remark	Ref. No.	Part No.	Description	Remark
C807	1-104-665-11	ELECT	100uF 20% 10V	CC61	1-128-809-11	CERAMIC 100PF 5% 50V	(DE595:AEP,UK,AUS,KR,TW)
C808	1-126-935-11	ELECT	470uF 20% 10V	CC62	1-128-809-11	CERAMIC 100PF 5% 50V	(DE595:AEP,UK,AUS,KR,TW)
C810	1-164-159-11	CERAMIC	0.1uF 50V	< CONNECTOR >			
C811	1-164-159-11	CERAMIC	0.1uF 50V	CNP501	1-573-845-11	CONNECTOR, BOARD TO BOARD 13P	
C820	1-164-159-11	CERAMIC	0.1uF 50V	CNP502	1-784-038-21	CONNECTOR, BOARD TO BOARD 9P	
C821	1-164-159-11	CERAMIC	0.1uF 50V	* CNP801	1-564-104-00	PIN, CONNECTOR (3.96mm PITCH) 3P	
C822	1-126-947-11	ELECT	47uF 20% 35V	CNP802	1-691-767-11	PLUG (MICRO CONNECTOR) 5P	
C830	1-164-159-11	CERAMIC	0.1uF 50V	CNP911	1-784-929-11	PIN, CONNECTOR 14P	
C900	1-128-825-11	CERAMIC	0.0022uF 5% 50V	CNP915	1-770-480-11	SOCKET, CONNECTOR 4P	
C901	1-164-159-11	CERAMIC	0.1uF 50V	< DIODE >			
C903	1-126-936-11	ELECT	3300uF 20% 16V	D505	8-719-911-19	DIODE 1SS119-25	
CC02	1-128-809-11	CERAMIC	100PF 5% 50V	D510	8-719-911-19	DIODE 1SS119-25	
CC04	1-128-809-11	CERAMIC	100PF 5% 50V	D540	8-719-911-19	DIODE 1SS119-25	
CC05	1-128-809-11	CERAMIC	100PF 5% 50V	D560	8-719-911-19	DIODE 1SS119-25	
CC06	1-128-809-11	CERAMIC	100PF 5% 50V	D605	8-719-911-19	DIODE 1SS119-25	
CC07	1-128-809-11	CERAMIC	100PF 5% 50V	D610	8-719-911-19	DIODE 1SS119-25	
CC08	1-128-809-11	CERAMIC	100PF 5% 50V	D640	8-719-911-19	DIODE 1SS119-25	
CC09	1-128-809-11	CERAMIC	100PF 5% 50V	D665	8-719-911-19	DIODE 1SS119-25	
CC12	1-127-876-11	CERAMIC	0.01uF 10% 50V	D680	8-719-911-19	DIODE 1SS119-25	
CC14	1-127-876-11	CERAMIC	0.01uF 10% 50V	D690	8-719-934-21	DIODE HZS30-1L	
CC16	1-127-876-11	CERAMIC	0.01uF 10% 50V	D691	8-719-911-19	DIODE 1SS119-25	
CC18	1-127-876-11	CERAMIC	0.01uF 10% 50V	D705	8-719-911-19	DIODE 1SS119-25	
CC20	1-127-876-11	CERAMIC	0.01uF 10% 50V	D710	8-719-911-19	DIODE 1SS119-25	
CC31	1-128-809-11	CERAMIC	100PF 5% 50V	D721	8-719-911-19	DIODE 1SS119-25	
CC32	1-128-809-11	CERAMIC	100PF 5% 50V	D722	8-719-911-19	DIODE 1SS119-25	
CC33	1-127-876-11	CERAMIC	0.01uF 10% 50V	D731	8-719-911-19	DIODE 1SS119-25	
CC34	1-127-876-11	CERAMIC	0.01uF 10% 50V	D732	8-719-911-19	DIODE 1SS119-25	
CC41	1-128-809-11	CERAMIC	100PF 5% 50V	D733	8-719-911-19	DIODE 1SS119-25	
CC42	1-128-809-11	CERAMIC	100PF 5% 50V	D734	8-719-911-19	DIODE 1SS119-25	
CC52	1-128-809-11	CERAMIC	100PF 5% 50V	D740	8-719-911-19	DIODE 1SS119-25	
CC54	1-128-809-11	CERAMIC	100PF 5% 50V	D750	8-719-911-19	DIODE 1SS119-25	
CC55	1-128-809-11	CERAMIC	100PF 5% 50V	D765	8-719-911-19	DIODE 1SS119-25	
CC56	1-128-809-11	CERAMIC	100PF 5% 50V	D791	8-719-911-19	DIODE 1SS119-25	
CC57	1-128-809-11	CERAMIC	100PF 5% 50V	D801	8-719-934-21	DIODE HZS30-1L	
CC58	1-128-809-11	CERAMIC	100PF 5% 50V	D802	8-719-072-05	DIODE RBV-602LF-A	
CC59	1-128-809-11	CERAMIC	100PF 5% 50V	D804	8-719-068-24	DIODE HZ5.6BP-TK	
				D851	8-719-911-19	DIODE 1SS119-25 (DE595)	
				D896	8-719-043-76	DIODE AK04V0	
				D902	8-719-024-99	DIODE 11ES2-NTA2B	
				D903	8-719-024-99	DIODE 11ES2-NTA2B	
				D904	8-719-024-99	DIODE 11ES2-NTA2B	
				D905	8-719-024-99	DIODE 11ES2-NTA2B	
				< IC >			
				IC201	6-703-501-01	IC M61527FP	
				IC401	8-759-636-74	IC M5218AP-22	
				IC501	8-749-011-16	IC STK350-230	
				IC601	8-759-636-74	IC M5218AP-22	
				IC701	6-700-943-01	IC uPC2581V-S	
				IC702	6-700-943-01	IC uPC2581V-S	
				IC801	8-759-649-68	IC uPC78M07AHF	
				IC802	8-759-604-95	IC M5F79M07L	

STR-DE495/DE595

Ver 1.1

MAIN

Ref. No.	Part No.	Description	Remark	Ref. No.	Part No.	Description	Remark
		< JACK >					
J401	1-793-775-12	JACK, PIN 6P (MULTI CH IN FRONT,SURROUND,CENTER,SUB WOOFER) (DE595)		Q748	8-729-900-36	TRANSISTOR DTC124ES	
J402	1-794-981-11	JACK, PIN 4P (CD IN,MD/TAPE OUT) (DE495)		Q750	8-729-281-53	TRANSISTOR 2SC1815-GR	
J402	1-794-981-11	JACK, PIN 4P (CD/SACD IN,MD/TAPE OUT) (DE595)		Q751	8-729-119-76	TRANSISTOR 2SA1175-HFE	
J403	1-794-981-11	JACK, PIN 4P (MD/TAPE IN,DVD AUDIO IN)		Q752	8-729-141-30	TRANSISTOR 2SC3623A-LK	
J404	1-774-411-11	JACK, PIN 6P (VIDEO 2 AUDIO IN, VIDEO 1 AUDIO OUT,VIDEO 1 AUDIO IN)		Q755	8-729-140-82	TRANSISTOR 2SA988-PAFAEA	
J405	1-774-785-11	JACK, PIN 1P (SUB WOOFER AUDIO OUT)		Q756	8-729-140-82	TRANSISTOR 2SA988-PAFAEA	
		< COIL >		Q790	8-729-119-79	TRANSISTOR 2SC2785-FEK	
L521	1-422-009-13	COIL, AIR-CORE		Q801	8-729-140-97	TRANSISTOR 2SB734-34	
L601	1-422-009-13	COIL, AIR-CORE		Q851	8-729-119-79	TRANSISTOR 2SC2785-FEK (DE595)	
L651	1-422-009-13	COIL, AIR-CORE				< RESISTOR >	
L701	1-422-009-13	COIL, AIR-CORE		R360	1-249-441-11	CARBON 100K 5% 1/4W	
L751	1-422-009-13	COIL, AIR-CORE		R361	1-249-425-11	CARBON 4.7K 5% 1/4W	
		< TRANSISTOR >		R362	1-249-425-11	CARBON 4.7K 5% 1/4W	
Q361	8-729-823-22	TRANSISTOR 2SC3576		R363	1-249-441-11	CARBON 100K 5% 1/4W	
Q362	8-729-823-22	TRANSISTOR 2SC3576		R366	1-249-429-11	CARBON 10K 5% 1/4W	
Q363	8-729-823-22	TRANSISTOR 2SC3576		R367	1-249-441-11	CARBON 100K 5% 1/4W	
Q364	8-729-823-22	TRANSISTOR 2SA1175-HFE		R368	1-249-437-11	CARBON 47K 5% 1/4W	
Q365	8-729-823-22	TRANSISTOR 2SC3576		R369	1-249-425-11	CARBON 4.7K 5% 1/4W	
Q366	8-729-823-22	TRANSISTOR 2SC3576		R370	1-249-425-11	CARBON 4.7K 5% 1/4W	
Q379	8-729-900-63	TRANSISTOR DTA124ES		R371	1-249-441-11	CARBON 100K 5% 1/4W	
Q471	8-729-823-22	TRANSISTOR 2SC3576		R372	1-249-441-11	CARBON 100K 5% 1/4W	
Q501	8-729-119-76	TRANSISTOR 2SA1175-HFE		R373	1-249-417-11	CARBON 1K 5% 1/4W	
Q502	8-729-141-30	TRANSISTOR 2SC3623A-LK		R374	1-249-417-11	CARBON 1K 5% 1/4W	
Q505	8-729-140-82	TRANSISTOR 2SA988-PAFAEA		R375	1-249-417-11	CARBON 1K 5% 1/4W	
Q506	8-729-140-82	TRANSISTOR 2SA988-PAFAEA		R376	1-249-417-11	CARBON 1K 5% 1/4W	
Q540	8-729-281-53	TRANSISTOR 2SC1815-GR		R377	1-249-417-11	CARBON 1K 5% 1/4W	
Q550	8-729-119-79	TRANSISTOR 2SC2785-FEK		R378	1-249-417-11	CARBON 1K 5% 1/4W	
Q560	8-729-119-79	TRANSISTOR 2SC2785-FEK		R379	1-249-425-11	CARBON 4.7K 5% 1/4W	
Q601	8-729-119-76	TRANSISTOR 2SA1175-HFE		R380	1-249-441-11	CARBON 100K 5% 1/4W	
Q602	8-729-141-30	TRANSISTOR 2SC3623A-LK		R381	1-249-429-11	CARBON 10K 5% 1/4W	
Q605	8-729-140-82	TRANSISTOR 2SA988-PAFAEA		R402	1-249-417-11	CARBON 1K 5% 1/4W	
Q606	8-729-140-82	TRANSISTOR 2SA988-PAFAEA		R404	1-249-417-11	CARBON 1K 5% 1/4W	
Q610	8-729-119-79	TRANSISTOR 2SC2785-FEK		R405	1-249-417-11	CARBON 1K 5% 1/4W	
Q640	8-729-281-53	TRANSISTOR 2SC1815-GR		R406	1-249-417-11	CARBON 1K 5% 1/4W	
Q651	8-729-119-76	TRANSISTOR 2SA1175-HFE		R407	1-249-417-11	CARBON 1K 5% 1/4W	
Q652	8-729-141-30	TRANSISTOR 2SC3623A-LK		R408	1-249-417-11	CARBON 1K 5% 1/4W	
Q655	8-729-140-82	TRANSISTOR 2SA988-PAFAEA		R409	1-249-417-11	CARBON 1K 5% 1/4W	
Q656	8-729-140-82	TRANSISTOR 2SA988-PAFAEA		R410	1-249-437-11	CARBON 47K 5% 1/4W	
Q680	8-729-281-53	TRANSISTOR 2SC1815-GR		R411	1-249-417-11	CARBON 1K 5% 1/4W (DE595)	
Q691	8-729-281-53	TRANSISTOR 2SC1815-GR		R412	1-249-417-11	CARBON 1K 5% 1/4W (DE595)	
Q692	8-729-900-63	TRANSISTOR DTA124ES		R430	1-249-437-11	CARBON 47K 5% 1/4W	
Q701	8-729-119-76	TRANSISTOR 2SA1175-HFE		R431	1-249-417-11	CARBON 1K 5% 1/4W (DE595)	
Q702	8-729-141-30	TRANSISTOR 2SC3623A-LK		R432	1-249-417-11	CARBON 1K 5% 1/4W (DE595)	
Q705	8-729-140-82	TRANSISTOR 2SA988-PAFAEA		R452	1-249-417-11	CARBON 1K 5% 1/4W	
Q706	8-729-140-82	TRANSISTOR 2SA988-PAFAEA		R454	1-249-417-11	CARBON 1K 5% 1/4W	
Q710	8-729-119-79	TRANSISTOR 2SC2785-FEK		R455	1-249-417-11	CARBON 1K 5% 1/4W	
Q722	8-729-140-84	TRANSISTOR 2SC1841-PAFAEA		R456	1-249-417-11	CARBON 1K 5% 1/4W	
Q723	8-729-119-79	TRANSISTOR 2SC2785-FEK		R457	1-249-417-11	CARBON 1K 5% 1/4W	
Q725	8-729-140-82	TRANSISTOR 2SA988-PAFAEA		R458	1-249-417-11	CARBON 1K 5% 1/4W	
Q740	8-729-281-53	TRANSISTOR 2SC1815-GR		R459	1-249-417-11	CARBON 1K 5% 1/4W	
Q747	8-729-900-63	TRANSISTOR DTA124ES		R461	1-249-417-11	CARBON 1K 5% 1/4W (DE595)	
				R462	1-249-417-11	CARBON 1K 5% 1/4W (DE595)	

Ref. No.	Part No.	Description	Remark	Ref. No.	Part No.	Description	Remark
R469	1-249-417-11	CARBON	1K 5% 1/4W	R625	1-249-439-11	CARBON	68K 5% 1/4W
R470	1-249-437-11	CARBON	47K 5% 1/4W	R631	1-249-425-11	CARBON	4.7K 5% 1/4W
R471	1-249-415-11	CARBON	680 5% 1/4W	R634	1-249-404-81	CARBON	82 5% 1/4W
R472	1-249-417-11	CARBON	1K 5% 1/4W	R638	1-249-439-11	CARBON	68K 5% 1/4W
R473	1-249-425-11	CARBON	4.7K 5% 1/4W	R640	1-249-433-11	CARBON	22K 5% 1/4W
R474	1-249-429-11	CARBON	10K 5% 1/4W	R648	1-247-843-11	CARBON	3.3K 5% 1/4W (DE495)
R475	1-249-421-11	CARBON	2.2K 5% 1/4W	R648	1-249-427-11	CARBON	6.8K 5% 1/4W (DE595)
R479	1-249-421-11	CARBON	2.2K 5% 1/4W	R651	1-249-417-11	CARBON	1K 5% 1/4W
R499	1-249-437-11	CARBON	47K 5% 1/4W	R652	1-249-439-11	CARBON	68K 5% 1/4W
R501	1-249-417-11	CARBON	1K 5% 1/4W	R653	1-249-421-11	CARBON	2.2K 5% 1/4W
R502	1-249-439-11	CARBON	68K 5% 1/4W	R654	1-249-439-11	CARBON	68K 5% 1/4W
R503	1-249-421-11	CARBON	2.2K 5% 1/4W	R655	1-249-433-11	CARBON	22K 5% 1/4W
R504	1-249-411-11	CARBON	330 5% 1/4W	R656	1-249-433-11	CARBON	22K 5% 1/4W
R505	1-249-439-11	CARBON	68K 5% 1/4W	R657	1-249-431-11	CARBON	15K 5% 1/4W
R510	1-249-421-11	CARBON	2.2K 5% 1/4W	R660	1-249-421-11	CARBON	2.2K 5% 1/4W
R511	1-249-440-11	CARBON	82K 5% 1/4W	R661	1-249-440-11	CARBON	82K 5% 1/4W
R513	1-249-414-11	CARBON	560 5% 1/4W	R663	1-249-414-11	CARBON	560 5% 1/4W
R514	1-249-405-11	CARBON	100 5% 1/4W	R664	1-249-405-11	CARBON	100 5% 1/4W
R515	1-249-405-11	CARBON	100 5% 1/4W	R665	1-249-405-11	CARBON	100 5% 1/4W
R516	1-234-182-11	ENCAPSULATED COMPONENT 0.22X2	5W	R666	1-234-182-11	ENCAPSULATED COMPONENT 0.22X2	5W
R517	1-249-393-11	CARBON	10 5% 1/4W	R667	1-249-393-11	CARBON	10 5% 1/4W
R520	1-249-425-11	CARBON	4.7K 5% 1/4W	R668	1-249-389-11	CARBON	4.7 5% 1/4W
R521	1-247-850-11	CARBON	6.2K 5% 1/4W	R669	1-249-425-11	CARBON	4.7K 5% 1/4W
R522	1-249-419-11	CARBON	1.5K 5% 1/4W	R671	1-247-850-11	CARBON	6.2K 5% 1/4W
R524	1-249-431-11	CARBON	15K 5% 1/4W	R672	1-249-419-11	CARBON	1.5K 5% 1/4W
R525	1-249-439-11	CARBON	68K 5% 1/4W	R673	1-249-437-11	CARBON	47K 5% 1/4W
R528	1-249-389-11	CARBON	4.7 5% 1/4W	R674	1-249-431-11	CARBON	15K 5% 1/4W
R531	1-249-425-11	CARBON	4.7K 5% 1/4W	R675	1-249-433-11	CARBON	22K 5% 1/4W
R532	1-249-425-11	CARBON	4.7K 5% 1/4W	R676	1-249-433-11	CARBON	22K 5% 1/4W
R533	1-249-437-11	CARBON	47K 5% 1/4W	R677	1-249-431-11	CARBON	15K 5% 1/4W
R534	1-249-404-81	CARBON	82 5% 1/4W	R680	1-249-433-11	CARBON	22K 5% 1/4W
R540	1-249-433-11	CARBON	22K 5% 1/4W	R681	1-247-843-11	CARBON	3.3K 5% 1/4W (DE495)
R546	1-247-843-11	CARBON	3.3K 5% 1/4W (DE495)	R681	1-249-427-11	CARBON	6.8K 5% 1/4W (DE595)
R546	1-249-427-11	CARBON	6.8K 5% 1/4W (DE595)	R690	1-247-887-00	CARBON	220K 5% 1/4W
R555	1-249-433-11	CARBON	22K 5% 1/4W	△ R691	1-215-888-00	METAL OXIDE	220 5% 2W F (US,CND)
R556	1-249-433-11	CARBON	22K 5% 1/4W	△ R691	1-216-453-00	METAL OXIDE	270 5% 2W F (EXCEPT US,CND)
R557	1-249-431-11	CARBON	15K 5% 1/4W	△ R692	1-215-889-00	METAL OXIDE	330 5% 2W F
R560	1-249-429-11	CARBON	10K 5% 1/4W	R693	1-249-429-11	CARBON	10K 5% 1/4W
R573	1-249-437-11	CARBON	47K 5% 1/4W	R694	1-249-429-11	CARBON	10K 5% 1/4W
R601	1-249-417-11	CARBON	1K 5% 1/4W	R695	1-249-429-11	CARBON	10K 5% 1/4W
R602	1-249-439-11	CARBON	68K 5% 1/4W	R696	1-249-435-11	CARBON	33K 5% 1/4W
R603	1-249-421-11	CARBON	2.2K 5% 1/4W	R698	1-249-429-11	CARBON	10K 5% 1/4W
R604	1-249-439-11	CARBON	68K 5% 1/4W	R699	1-247-895-00	CARBON	470K 5% 1/4W
R610	1-249-421-11	CARBON	2.2K 5% 1/4W	R701	1-249-417-11	CARBON	1K 5% 1/4W
R611	1-249-440-11	CARBON	82K 5% 1/4W	R702	1-249-439-11	CARBON	68K 5% 1/4W
R613	1-249-414-11	CARBON	560 5% 1/4W	R703	1-249-421-11	CARBON	2.2K 5% 1/4W
R614	1-249-405-11	CARBON	100 5% 1/4W	R704	1-249-439-11	CARBON	68K 5% 1/4W
R615	1-249-405-11	CARBON	100 5% 1/4W	R710	1-249-421-11	CARBON	2.2K 5% 1/4W
R616	1-234-182-11	ENCAPSULATED COMPONENT 0.22X2	5W	R711	1-249-440-11	CARBON	82K 5% 1/4W
R617	1-249-393-11	CARBON	10 5% 1/4W	R713	1-249-414-11	CARBON	560 5% 1/4W
R618	1-249-389-11	CARBON	4.7 5% 1/4W	R714	1-249-405-11	CARBON	100 5% 1/4W
R620	1-249-425-11	CARBON	4.7K 5% 1/4W	R715	1-249-405-11	CARBON	100 5% 1/4W
R621	1-247-850-11	CARBON	6.2K 5% 1/4W	R716	1-234-182-11	ENCAPSULATED COMPONENT 0.22X2	5W
R622	1-249-419-11	CARBON	1.5K 5% 1/4W				
R623	1-249-437-11	CARBON	47K 5% 1/4W				
R624	1-249-431-11	CARBON	15K 5% 1/4W				

The components identified by mark △ or dotted line with mark △ are critical for safety. Replace only with part number specified.

Les composants identifiés par une marque △ sont critiques pour la sécurité. Ne les remplacer que par une pièce portant le numéro spécifié.

STR-DE495/DE595

Ver 1.1

MAIN	POWER	STANDBY
-------------	--------------	----------------

Ref. No.	Part No.	Description	Remark
R717	1-249-393-11	CARBON 10	5% 1/4W
R718	1-249-389-11	CARBON 4.7	5% 1/4W
R719	1-249-425-11	CARBON 4.7K	5% 1/4W
R721	1-247-850-11	CARBON 6.2K	5% 1/4W
R722	1-249-419-11	CARBON 1.5K	5% 1/4W
R723	1-249-437-11	CARBON 47K	5% 1/4W
R724	1-249-431-11	CARBON 15K	5% 1/4W
R725	1-249-439-11	CARBON 68K	5% 1/4W
R731	1-249-425-11	CARBON 4.7K	5% 1/4W
R732	1-249-381-11	CARBON 1	5% 1/4W
R733	1-249-381-11	CARBON 1	5% 1/4W
R734	1-249-404-81	CARBON 82	5% 1/4W
R735	1-249-427-11	CARBON 6.8K	5% 1/4W
R736	1-249-417-11	CARBON 1K	5% 1/4W
R737	1-249-436-11	CARBON 39K	5% 1/4W
R740	1-249-433-11	CARBON 22K	5% 1/4W
R742	1-249-437-11	CARBON 47K	5% 1/4W
R743	1-249-433-11	CARBON 22K	5% 1/4W
R744	1-249-433-11	CARBON 22K	5% 1/4W
R745	1-249-433-11	CARBON 22K	5% 1/4W
R746	1-249-433-11	CARBON 22K	5% 1/4W
R747	1-249-431-11	CARBON 15K	5% 1/4W
R748	1-247-843-11	CARBON 3.3K	5% 1/4W (DE495)
R748	1-249-427-11	CARBON 6.8K	5% 1/4W (DE595)
R750	1-249-433-11	CARBON 22K	5% 1/4W
R751	1-249-417-11	CARBON 1K	5% 1/4W
R752	1-249-439-11	CARBON 68K	5% 1/4W
R753	1-249-421-11	CARBON 2.2K	5% 1/4W
R754	1-249-439-11	CARBON 68K	5% 1/4W
R755	1-249-433-11	CARBON 22K	5% 1/4W
R756	1-249-433-11	CARBON 22K	5% 1/4W
R757	1-249-431-11	CARBON 15K	5% 1/4W
R758	1-247-843-11	CARBON 3.3K	5% 1/4W (DE495)
R758	1-249-427-11	CARBON 6.8K	5% 1/4W (DE595)
R760	1-249-421-11	CARBON 2.2K	5% 1/4W
R761	1-249-440-11	CARBON 82K	5% 1/4W
R763	1-249-414-11	CARBON 560	5% 1/4W
R764	1-249-405-11	CARBON 100	5% 1/4W
R765	1-249-405-11	CARBON 100	5% 1/4W
R766	1-234-182-11	ENCAPSULATED COMPONENT 0.22X2	5W
R767	1-249-393-11	CARBON 10	5% 1/4W
R768	1-249-389-11	CARBON 4.7	5% 1/4W
R769	1-249-425-11	CARBON 4.7K	5% 1/4W
R770	1-249-437-11	CARBON 47K	5% 1/4W
R771	1-247-850-11	CARBON 6.2K	5% 1/4W
R772	1-249-419-11	CARBON 1.5K	5% 1/4W
R773	1-249-437-11	CARBON 47K	5% 1/4W
R775	1-249-439-11	CARBON 68K	5% 1/4W
R778	1-249-431-11	CARBON 15K	5% 1/4W
R780	1-249-429-11	CARBON 10K	5% 1/4W
R791	1-249-425-11	CARBON 4.7K	5% 1/4W
△R792	1-215-868-00	METAL OXIDE 680	5% 1W F
R793	1-249-404-81	CARBON 82	5% 1/4W
△R794	1-215-868-00	METAL OXIDE 680	5% 1W F
R802	1-249-404-81	CARBON 82	5% 1/4W

Ref. No.	Part No.	Description	Remark
R803	1-249-389-11	CARBON 4.7	5% 1/4W
R804	1-249-426-11	CARBON 5.6K	5% 1/4W
R806	1-249-433-11	CARBON 22K	5% 1/4W
R851	1-249-404-81	CARBON 82	5% 1/4W (DE595)
R852	1-249-425-11	CARBON 4.7K	5% 1/4W (DE595)
△R910	1-243-635-11	FUSIBLE 0.33	5% 1/2W F
RR11	1-249-393-11	CARBON 10	5% 1/4W (AEP,UK,AUS,KR,TW)
RR12	1-249-393-11	CARBON 10	5% 1/4W (AEP,UK,AUS,KR,TW)
RR13	1-249-393-11	CARBON 10	5% 1/4W (AEP,UK,AUS,KR,TW)
RR14	1-249-393-11	CARBON 10	5% 1/4W (AEP,UK,AUS,KR,TW)
RR15	1-249-393-11	CARBON 10	5% 1/4W (AEP,UK,AUS,KR,TW)
RR16	1-249-393-11	CARBON 10	5% 1/4W (DE595:AEP,UK,AUS,KR,TW)
RR17	1-249-393-11	CARBON 10	5% 1/4W (DE595:AEP,UK,AUS,KR,TW)
< RELAY >			
RY501	1-515-921-11	RELAY (12V)	
RY560	1-755-267-11	RELAY	
RY601	1-515-921-11	RELAY (12V)	
RY701	1-515-921-11	RELAY (12V)	
RY791	1-515-921-11	RELAY (12V)	
RY851	1-515-921-11	RELAY (12V) (DE595)	
< TERMINAL >			
TM601	1-694-805-11	TERMINAL BOARD (SPEAKERS SURROUND,CENTER)	
TM602	1-694-785-11	TERMINAL BOARD (SPEAKERS FRONT) (DE495)	
TM602	1-694-785-11	TERMINAL BOARD (SPEAKERS FRONT A) (DE595)	
TM603	1-694-785-11	TERMINAL BOARD (SPEAKERS FRONT B) (DE595)	

POWER BOARD			

< CONNECTOR >			
* CNP102	1-564-518-11	PLUG, CONNECTOR 3P	
< SWITCH >			
S151	1-771-410-21	SWITCH, TACTILE (SPEAKERS) (DE595)	
S152	1-771-410-21	SWITCH, TACTILE (I/Ⓢ)	

1-686-904-11	STANDBY BOARD	*****	
1-533-293-11	HOLDER, FUSE		
< CAPACITOR >			
C813	1-164-159-11	CERAMIC 0.1uF	50V
C814	1-164-159-11	CERAMIC 0.1uF	50V
C815	1-126-943-11	ELECT 2200uF	20% 25V

The components identified by mark △ or dotted line with mark △ are critical for safety. Replace only with part number specified.	Les composants identifiés par une marque △ sont critiques pour la sécurité. Ne les remplacer que par une pièce portant le numéro spécifié.
--	--

STANDBY

VIDEO

Ref. No.	Part No.	Description	Remark	Ref. No.	Part No.	Description	Remark
C816	1-126-942-61	ELECT	1000uF 20% 25V	△ T902	1-435-435-11	TRANSFORMER, POWER (AEP,UK,AUS,SP,MY,AR,KR)	
C920	1-164-159-11	CERAMIC	0.1uF 50V	△ T902	1-435-563-11	TRANSFORMER, POWER (TW)	*****
C921	1-164-159-11	CERAMIC	0.1uF 50V				
C923	1-126-959-11	ELECT	0.47uF 20% 50V				
C950	1-126-936-11	ELECT	3300uF 20% 16V				
		< CONNECTOR >			A-4731-175-A	VIDEO BOARD, COMPLETE (DE495,DE595:AEP,UK)	
CNP901	1-564-321-00	PIN, CONNECTOR (3.96mm PITCH) 2P			1-686-905-11	VIDEO BOARD (EXCEPT DE495,DE595:AEP,UK)	*****
CNP902	1-580-843-11	PIN, CONNECTOR (POWER) 2P				< CAPACITOR >	
CNP903	1-564-506-11	PLUG, CONNECTOR 3P					
CNP905	1-779-495-11	PLUG, CONNECTOR 4P					
CNP906	1-568-106-11	PIN, CONNECTOR (3.96mm PITCH) 4P (E2)		C200	1-128-805-11	CERAMIC	47PF 5% 50V
				C201	1-128-805-11	CERAMIC	47PF 5% 50V
CNP912	1-779-978-11	PIN, CONNECTOR 3P		C206	1-126-964-11	ELECT	10uF 20% 50V
		< DIODE >		C207	1-126-964-11	ELECT	10uF 20% 50V
D820	8-719-024-99	DIODE 11ES2-NTA2B		C208	1-126-964-11	ELECT	10uF 20% 50V
D821	8-719-024-99	DIODE 11ES2-NTA2B					
D822	8-719-024-99	DIODE 11ES2-NTA2B		C210	1-126-964-11	ELECT	10uF 20% 50V
D823	8-719-024-99	DIODE 11ES2-NTA2B		C213	1-126-934-11	ELECT	220uF 20% 10V
D901	8-719-911-19	DIODE 1SS119-25		C214	1-164-159-11	CERAMIC	0.1uF 50V
				C215	1-164-159-11	CERAMIC	0.1uF 50V
D910	8-719-024-99	DIODE 11ES2-NTA2B		C248	1-128-825-11	CERAMIC	0.0022uF 5% 50V
D911	8-719-024-99	DIODE 11ES2-NTA2B					
D912	8-719-024-99	DIODE 11ES2-NTA2B		C301	1-126-935-11	ELECT	470uF 20% 10V (EXCEPT DE495,DE595:AEP,UK)
D913	8-719-024-99	DIODE 11ES2-NTA2B		C302	1-126-935-11	ELECT	470uF 20% 10V (EXCEPT DE495,DE595:AEP,UK)
D914	8-719-911-19	DIODE 1SS119-25		C303	1-126-935-11	ELECT	470uF 20% 10V (EXCEPT DE495,DE595:AEP,UK)
D915	8-719-911-19	DIODE 1SS119-25		C308	1-126-964-11	ELECT	10uF 20% 50V (EXCEPT DE495,DE595:AEP,UK)
		< EARTH TERMINAL >		C309	1-126-964-11	ELECT	10uF 20% 50V (EXCEPT DE495,DE595:AEP,UK)
* G901	1-537-738-21	TERMINAL, EARTH (US,CND)					
		< TRANSISTOR >		C310	1-126-964-11	ELECT	10uF 20% 50V (EXCEPT DE495,DE595:AEP,UK)
Q901	8-729-119-79	TRANSISTOR 2SC2785-FEK		C311	1-126-964-11	ELECT	10uF 20% 50V (EXCEPT DE495,DE595:AEP,UK)
Q921	8-729-119-79	TRANSISTOR 2SC2785-FEK		C312	1-126-964-11	ELECT	10uF 20% 50V (EXCEPT DE495,DE595:AEP,UK)
		< RESISTOR >		C313	1-126-964-11	ELECT	10uF 20% 50V (EXCEPT DE495,DE595:AEP,UK)
△ R810	1-243-634-11	FUSIBLE	0.22 5% 1/2W F	C317	1-126-947-11	ELECT	47uF 20% 25V (EXCEPT DE495,DE595:AEP,UK)
△ R812	1-243-634-11	FUSIBLE	0.22 5% 1/2W F				
△ R901	1-219-237-11	SOLID	3.3M 20% 1/2W F (US,CND)	C329	1-164-159-11	CERAMIC	0.1uF 50V (EXCEPT DE495,DE595:AEP,UK)
R902	1-249-437-11	CARBON	47K 5% 1/4W	C330	1-164-159-11	CERAMIC	0.1uF 50V (EXCEPT DE495,DE595:AEP,UK)
R903	1-249-425-11	CARBON	4.7K 5% 1/4W	C331	1-164-159-11	CERAMIC	0.1uF 50V (EXCEPT DE495,DE595:AEP,UK)
R904	1-249-381-11	CARBON	1 5% 1/4W	C332	1-164-159-11	CERAMIC	0.1uF 50V (EXCEPT DE495,DE595:AEP,UK)
R921	1-249-437-11	CARBON	47K 5% 1/4W	C338	1-126-947-11	ELECT	47uF 20% 25V (EXCEPT DE495,DE595:AEP,UK)
R922	1-249-435-11	CARBON	33K 5% 1/4W				
R923	1-249-429-11	CARBON	10K 5% 1/4W	C809	1-126-934-11	ELECT	220uF 20% 10V
		< RELAY >		C824	1-164-159-11	CERAMIC	0.1uF 50V
△ RY901	1-755-298-11	RELAY		C825	1-164-159-11	CERAMIC	0.1uF 50V
		< VOLTAGE SELECTOR >		C827	1-126-947-11	ELECT	47uF 20% 25V
△ S901	1-786-055-21	SELECTOR, VOLTAGE (VOLTAGE SELECTOR) (E2)					
		< TRANSFORMER >					
△ T902	1-435-281-11	TRANSFORMER, POWER (US,CND,MX)					
△ T902	1-435-434-11	TRANSFORMER, POWER (E2)		CNP156	1-691-765-11	PLUG (MICRO CONNECTOR) 3P	
				CNS250	1-569-315-11	SOCKET, CONNECTOR 5P	

The components identified by mark △ or dotted line with mark △ are critical for safety. Replace only with part number specified.

Les composants identifiés par une marque △ sont critiques pour la sécurité. Ne les remplacer que par une pièce portant le numéro spécifié.

STR-DE495/DE595

Ver 1.1

VIDEO **VOL**

Ref. No.	Part No.	Description	Remark
		< DIODE >	
D203	8-719-911-19	DIODE 1SS119-25	
D204	8-719-911-19	DIODE 1SS119-25	
		< IC >	
IC203	6-701-890-01	IC NJM2595D	
IC301	8-759-231-66	IC TC74HC4053AP	(EXCEPT DE495,DE595:AEP,UK)
IC302	6-701-891-01	IC NJM2581D	(EXCEPT DE495,DE595:AEP,UK)
IC804	8-759-701-65	IC NJM79M05FA	
IC807	8-759-231-53	IC TA7805S	
		< JACK >	
J200	1-794-978-11	JACK, PIN 3P (DVD VIDEO IN, VIDEO 2 VIDEO IN,VIDEO 1 VIDEO OUT)	
J201	1-815-043-11	JACK, PIN 2P (VIDEO 1 VIDEO IN, MONITOR VIDEO OUT)	
J301	1-816-592-11	JACK, PIN 9P (COMPONENT VIDEO DVD IN,VIDEO 2 IN,MONITOR OUT) (EXCEPT DE495,DE595:AEP,UK)	
		< TRANSISTOR >	
Q301	8-729-116-02	TRANSISTOR BA1A4M-TP (EXCEPT DE495,DE595:AEP,UK)	
		< RESISTOR >	
R200	1-247-804-11	CARBON 75 5% 1/4W	
R201	1-247-804-11	CARBON 75 5% 1/4W	
R218	1-247-804-11	CARBON 75 5% 1/4W	
R220	1-247-804-11	CARBON 75 5% 1/4W	
R221	1-247-804-11	CARBON 75 5% 1/4W	
R301	1-247-804-11	CARBON 75 5% 1/4W (EXCEPT DE495,DE595:AEP,UK)	
R302	1-247-804-11	CARBON 75 5% 1/4W (EXCEPT DE495,DE595:AEP,UK)	
R303	1-247-804-11	CARBON 75 5% 1/4W (EXCEPT DE495,DE595:AEP,UK)	
R304	1-247-804-11	CARBON 75 5% 1/4W (EXCEPT DE495,DE595:AEP,UK)	
R305	1-247-804-11	CARBON 75 5% 1/4W (EXCEPT DE495,DE595:AEP,UK)	
R306	1-247-804-11	CARBON 75 5% 1/4W (EXCEPT DE495,DE595:AEP,UK)	
R307	1-247-804-11	CARBON 75 5% 1/4W (EXCEPT DE495,DE595:AEP,UK)	
R308	1-247-804-11	CARBON 75 5% 1/4W (EXCEPT DE495,DE595:AEP,UK)	
R309	1-247-804-11	CARBON 75 5% 1/4W (EXCEPT DE495,DE595:AEP,UK)	
R310	1-249-417-11	CARBON 1K 5% 1/4W (EXCEPT DE495,DE595:AEP,UK)	
R311	1-249-417-11	CARBON 1K 5% 1/4W (EXCEPT DE495,DE595:AEP,UK)	
R312	1-249-417-11	CARBON 1K 5% 1/4W (EXCEPT DE495,DE595:AEP,UK)	
R313	1-249-433-11	CARBON 22K 5% 1/4W (EXCEPT DE495,DE595:AEP,UK)	
R325	1-249-429-11	CARBON 10K 5% 1/4W (EXCEPT DE495,DE595:AEP,UK)	
R347	1-247-807-31	CARBON 100 5% 1/4W (EXCEPT DE495,DE595:AEP,UK)	

Ref. No.	Part No.	Description	Remark
		VOL BOARD *****	
		< CONNECTOR >	
* CNP104	1-564-518-11	PLUG, CONNECTOR 3P	
		< ROTARY ENCODER >	
RV102	1-418-725-41	ENCODER, ROTARY (12 TYPE) (MASTER VOLUME)	

		MISCELLANEOUS *****	
58	1-773-154-11	WIRE (FLAT TYPE) (21 CORE)	
△ 103	1-696-847-11	CORD, POWER (AUS)	
△ 103	1-769-079-22	CORD, POWER (KR)	
△ 103	1-777-071-23	CORD, POWER (AEP,UK,E2,SP,MY)	
△ 103	1-783-532-11	CORD, POWER (US,CND,MX,TW)	
△ 103	1-783-941-12	CORD, POWER (AR)	
105	1-769-937-11	WIRE (FLAT TYPE) (11 CORE) (EXCEPT AEP,UK)	
105	1-773-001-11	WIRE (FLAT TYPE) (15 CORE) (AEP,UK)	
106	1-575-662-31	WIRE (FLAT TYPE) (5 CORE)	
△ F901	1-532-464-31	FUSE (T2.5AL/250V) (EXCEPT US,CND,MX,TW)	
△ F901	1-576-109-11	FUSE (5A/125V) (DE495:TW)	
△ F901	1-576-193-11	FUSE (6.3A/125V) (DE595:US,CND,MX,TW)	
Q503	8-749-010-25	TRANSISTOR MN2488-OPY-M	
Q504	8-749-010-26	TRANSISTOR MP1620-OPY-M	
Q603	8-749-010-25	TRANSISTOR MN2488-OPY-M	
Q604	8-749-010-26	TRANSISTOR MP1620-OPY-M	
Q653	8-749-010-25	TRANSISTOR MN2488-OPY-M	
Q654	8-749-010-26	TRANSISTOR MP1620-OPY-M	
Q703	8-749-010-25	TRANSISTOR MN2488-OPY-M	
Q704	8-749-010-26	TRANSISTOR MP1620-OPY-M	
Q753	8-749-010-25	TRANSISTOR MN2488-OPY-M	
Q754	8-749-010-26	TRANSISTOR MP1620-OPY-M	
△ T901	1-437-996-11	TRANSFORMER, POWER (DE495:AEP,UK,KR,SP,MY)	
△ T901	1-437-999-11	TRANSFORMER, POWER (DE495:AUS)	
△ T901	1-439-549-11	TRANSFORMER, POWER (DE595:US,MX)	
△ T901	1-439-550-11	TRANSFORMER, POWER (DE595:AEP,UK,AUS,AR,KR)	
△ T901	1-439-551-11	TRANSFORMER, POWER (DE595:SP,MY)	
△ T901	1-439-552-11	TRANSFORMER, POWER (DE595:TW)	
△ T901	1-439-553-11	TRANSFORMER, POWER (DE595:E2)	
△ T901	1-439-609-11	TRANSFORMER, POWER (DE595:CND)	
△ T901	1-439-640-11	TRANSFORMER, POWER (DE495:TW)	
TM301	1-693-577-22	TUNER PACK (ANTENNA) (US,CND,E2,MX,AR)	
TM301	1-693-578-22	TUNER PACK (ANTENNA) (AEP,UK)	
TM301	1-693-580-22	TUNER PACK (ANTENNA) (AUS,SP,MY,KR,TW)	

The components identified by mark △ or dotted line with mark △ are critical for safety. Replace only with part number specified.	Les composants identifiés par une marque △ sont critiques pour la sécurité. Ne les remplacer que par une pièce portant le numéro spécifié.
--	--

Ref. No.	Part No.	Description	Remark
		ACCESSORIES *****	
	1-477-204-41	COMMANDER, STANDARD (RM-U306A)	
	1-501-374-12	ANTENNA, LOOP (AM)	
	1-501-807-12	ANTENNA (FM) (AEP,UK,AUS,SP,MY)	
△	1-770-019-11	ADAPTOR, CONVERSION PLUG 3P (DE495:UK)	
△	1-770-019-51	ADAPTOR, CONVERSION PLUG 3P (DE595:UK)	
	1-793-184-22	CONNECTOR (F TYPE ADAPTOR) (US,CND,E2,AUS,MX)	
	4-228-696-01	COVER, BATTERY (for RM-U306A)	
	4-245-212-11	MANUAL, INSTRUCTION (DANISH,FINNISH) (AEP)	
	4-245-212-21	MANUAL, INSTRUCTION (PORTUGUESE) (AEP)	
	4-245-212-31	MANUAL, INSTRUCTION (RUSSIAN) (AEP)	
	4-245-327-11	MANUAL, INSTRUCTION (ENGLISH) (EXCEPT MX)	
	4-245-327-21	MANUAL, INSTRUCTION (FRENCH) (CND,AEP,E2,SP,MY)	
	4-245-327-31	MANUAL, INSTRUCTION (SPANISH) (AEP,E2,MX,SP,MY,AR)	
	4-245-327-41	MANUAL, INSTRUCTION (GERMAN,DUTCH, SWEDISH) (AEP)	
	4-245-327-51	MANUAL, INSTRUCTION (ITALIAN,POLISH) (AEP)	
	4-245-327-61	MANUAL, INSTRUCTION (TRADITIONAL CHINESE) (SP,MY,TW)	
	4-245-327-71	MANUAL, INSTRUCTION (KOREAN) (KR)	

The components identified by mark △ or dotted line with mark △ are critical for safety. Replace only with part number specified.

Les composants identifiés par une marque △ sont critiques pour la sécurité. Ne les remplacer que par une pièce portant le numéro spécifié.

