

# STR-K1600

## SERVICE MANUAL

Ver. 1.1 2007. 04

*E Model  
Australian Model*



Photo: Silver type

Manufactured under license from Dolby Laboratories. "Dolby", "Pro Logic", "Surround EX", and the double-D symbol are trademarks of Do by Laboratories. "DTS" and "DTS-ES | Neo:6" are registered trademarks of DTS, Inc. "96/24" is a trademark of DTS, Inc.

This receiver incorporates High-Definition Multimedia Interface (HDMI™) technology. HDMI, the HDMI logo and High-Definition Multimedia Interface are trademarks or registered trademarks of HDMI Licensing LLC.

### SPECIFICATIONS

#### Amplifier section

Power Output <sup>1)</sup>

Stereo mode output (rated) (6 ohms, 1 kHz, THD 1%)

90 W + 90 W <sup>1)</sup>  
85 W + 85 W <sup>3)</sup>

Surround mode output (reference) <sup>2)</sup>

RMS output  
FRONT: 185 W per channel <sup>1)</sup>  
170 W per channel <sup>3)</sup>  
(with SS-MSP16)

CENTER:

185 W <sup>1)</sup>  
170 W <sup>3)</sup>  
(with SS-CNP16)

SURROUND:

185 W per channel <sup>1)</sup>  
170 W per channel <sup>3)</sup>  
(with SS-SRP16)

SURROUND BACK: 185 W <sup>1)</sup>  
170 W <sup>3)</sup>  
(with SA-WP16)

1) Measured under the following conditions:

Area code	Power requirements
E51, AUS, MY, SP, TH	240 V AC, 50 Hz
MX	127 V AC, 60 Hz
AR	230 V AC, 50 Hz

2) Reference power output for front, center surround and surround back speakers Depending on the sound field settings and the source, there may be no sound output

3) Measured under the following conditions:

Area code	Power requirements
AR	220 V AC, 50 Hz

– Continued on next page –

## MULTI CHANNEL AV RECEIVER

9-887-570-02  
2007D04-1  
© 2007. 04

**Sony Corporation**  
Home Audio Division  
Published by Sony Techno Create Corporation

# SONY®

# STR-K1600

## Ver. 1.1

### Inputs

Analog                    Sensitivity: 800 mV/  
50 kohms  
Digital (Coaxial)       Impedance: 75 ohms

### Outputs (Analog)

AUDIO OUT                Voltage: 800 mV/10 kohms  
SUB WOOFER             Voltage: 2 V/1 kohm

### Tone

Gain levels               ±6 dB, 1 dB step

### Reproduction frequency range:

28 – 20,000 Hz

### FM tuner section

Tuning range             87.5 – 108.0 MHz  
Antenna                    FM wire antenna  
Antenna terminals       75 ohms, unbalanced  
Intermediate frequency   10.7 MHz

### AM tuner section

#### Tuning range

Models of area code AUS, MY, SP, TH  
With 9-kHz tuning scale: 531 – 1,602 kHz  
Models of area code E51  
With 10-kHz tuning scale: 530 – 1,610 kHz<sup>4)</sup>  
With 9-kHz tuning scale: 531 – 1,602 kHz<sup>4)</sup>  
Models of area code AR, MX  
With 10-kHz tuning scale: 530 – 1,610 kHz

Antenna                    Loop antenna  
Intermediate frequency   450 kHz

4) You can change the AM tuning scale to 9 kHz or 10 kHz  
After tuning in any AM station, turn off the receiver  
While holding down TUNING MODE, press I/⏪ All  
preset stations will be erased when you change the tuning  
scale. To reset the scale to 10 kHz (or 9 kHz), repeat the  
procedure

### Video section

#### Inputs/Outputs

Video:                     1 Vp-p, 75 ohms  
COMPONENT VIDEO: Y: 1 Vp-p, 75 ohms  
Pb/Cb: 0.7 Vp-p,  
75 ohms  
Pr/Cr: 0.7 Vp-p,  
75 ohms  
80 MHz HD Pass Through

### General

#### Power requirements

Area code	Power requirements
AUS	240 V AC, 50 Hz
MY, SP	230 – 240 V AC, 50/60 Hz
AR, TH	220 – 230 V AC, 50/60 Hz
MX	127 V AC, 60 Hz
E51	120/220/240 V AC, 50/60 Hz

#### Power output (DIGITAL MEDIA PORT)

(Models of area code AUS, MY, SP, TH only)

DC OUT:                    5 V, 700 mA  
Power consumption        200 W  
Power consumption (during standby mode)  
0.3 W

#### Dimensions (w/h/d) (Approx )

430 × 157.5 × 316 mm  
including projecting  
parts and controls

#### Mass (Approx )

8.0 kg

Design and specifications are subject to change  
without notice

#### • Abbreviation

E51 : Chilean and Peruvian models  
AUS : Australian model  
MY : Malaysia model  
SP : Singapore model  
TH : Thai model  
MX : Mexican model  
AR : Argentina model

**MODEL IDENTIFICATION**  
— BACK PANEL —

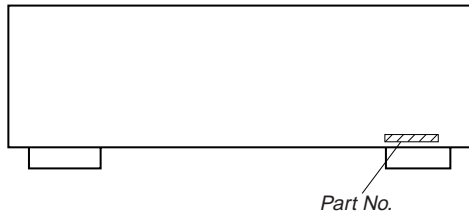

MODEL	PART No.
MY, SP	2-897-800-0□
AUS	2-897-800-1□
E51	2-897-800-2□
AR	2-897-800-3□
MX	2-897-800-4□
TH	3-208-699-0□

- Abbreviation
  - MY : Malaysia model
  - SP : Singapore model
  - AUS : Australian model
  - E51 : Chilean and Peruvian models
  - AR : Argentina model
  - MX : Mexican model
  - TH : Thai model

**SAFETY-RELATED COMPONENT WARNING!!**

COMPONENTS IDENTIFIED BY MARK  $\triangle$  OR DOTTED LINE WITH MARK  $\triangle$  ON THE SCHEMATIC DIAGRAMS AND IN THE PARTS LIST ARE CRITICAL TO SAFE OPERATION. REPLACE THESE COMPONENTS WITH SONY PARTS WHOSE PART NUMBERS APPEAR AS SHOWN IN THIS MANUAL OR IN SUPPLEMENTS PUBLISHED BY SONY.

## TABLE OF CONTENTS

<b>1. GENERAL</b>	
Description and location of parts .....	5
<b>2. DISASSEMBLY</b>	
2-1. Case .....	8
2-2. Back Panel Section .....	9
2-3. Front Panel Section .....	9
2-4. DIGITAL Board .....	10
2-5. MAIN Board Section .....	10
2-6. STANDBY Board .....	11
<b>3. TEST MODE</b> .....	12
<b>4. FM TUNER CHECK</b> .....	13
<b>5. DIAGRAMS</b>	
5-1. Block Diagram – Tuner/Audio Section – .....	15
5-2. Block Diagram – Digital Section – .....	16
5-3. Block Diagram – Video Section – .....	17
5-4. Block Diagram – HDMI SW Section – .....	18
5-5. Block Diagram – Key/Display Section – .....	19
5-6. Block Diagram – Power Section – .....	20
5-7. Printed Wiring Boards – Main Section – .....	22
5-8. Schematic Diagram – Main Section (1/2) – .....	23
5-9. Schematic Diagram – Main Section (2/2) – .....	24
5-10. Printed Wiring Board – Digital Section (1/2) – .....	25
5-11. Printed Wiring Board – Digital Section (2/2) – .....	26
5-12. Schematic Diagram – Digital Section (1/4) – .....	27
5-13. Schematic Diagram – Digital Section (2/4) – .....	28
5-14. Schematic Diagram – Digital Section (3/4) – .....	29
5-15. Schematic Diagram – Digital Section (4/4) – .....	30
5-16. Printed Wiring Boards – Video Section – .....	31
5-17. Schematic Diagram – Video Section – .....	32
5-18. Printed Wiring Board – HDMI SW Section – .....	33
5-19. Schematic Diagram – HDMI SW Section – .....	34
5-20. Printed Wiring Boards – DCAC, Power Key Section – ....	35
5-21. Schematic Diagram – DCAC, Power Key Section – .....	35
5-22. Printed Wiring Board – Display Section – .....	36
5-23. Schematic Diagram – Display Section – .....	37
5-24. Printed Wiring Board – Power Section – .....	38
5-25. Schematic Diagram – Power Section – .....	39
5-26. Printed Wiring Board – DCDC Section (AUS, MY, SP, TH model) – .....	40
5-27. Schematic Diagram – DCDC Section (AUS, MY, SP, TH model) – .....	40
<b>6. EXPLODED VIEWS</b>	
6-1. Case Section .....	49
6-2. Front Panel Section .....	50
6-3. Back Panel Section .....	51
6-4. Chassis Section .....	52
<b>7. ELECTRICAL PARTS LIST</b> .....	53

# SECTION 1 GENERAL

This section is extracted from instruction manual.

## Getting Started

### Description and location of parts

#### Receiver

#### Front panel

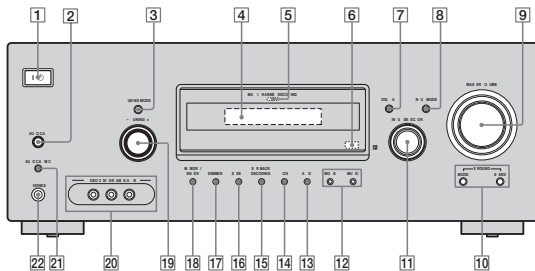

Name	Function
1 <b>W</b> (on/standby)	Press to turn the receiver on or off (page 31, 39, 40, 57, 70, 78).
2 <b>AUTO CAL</b>	Press to activate the Auto Calibration function (page 33).
3 <b>TUNING MODE</b>	Press to select the tuning mode (page 58, 61, 78).
4 <b>Display</b>	The current status of the selected component or a list of selectable items appears here (page 7).
5 <b>MULTICHANNEL DECODING lamp</b>	Lights up when multi channel audio is decoded (page 40).
6 <b>Remote sensor</b>	Receives signals from remote commander.

Name	Function
7 <b>DISPLAY</b>	Press to select information displayed on the display (page 66, 67).
8 <b>INPUT MODE</b>	Press to select the input mode when the same components are connected to both digital and analog jacks (page 62).
9 <b>MASTER VOLUME</b>	Turn to adjust the volume level of all speakers at the same time (page 36, 37, 39, 40).
10 <b>X-ROUND MODE</b>	Press to select the X-ROUND mode (page 66).
<b>X-ROUND SPEED</b>	Press to adjust the speed of X-ROUND effect (page 66).

continued

5<sup>66</sup>

Name	Function
11 <b>INPUT SELECTOR</b>	Turn to select the input source to playback (page 37, 39, 40, 58, 59, 60, 61, 62, 65, 67, 68, 69).
12 <b>MOVIE, MUSIC</b>	Press to select sound fields (MOVIE, MUSIC) (page 54).
13 <b>A.F.D.</b>	Press to select A.F.D. mode (page 52, 56).
14 <b>2CH</b>	Press to select 2CH STEREO mode (page 56, 57).
15 <b>SUR BACK DECODING</b>	Press to select the surround back decoding mode (page 46).
16 <b>SLEEP</b>	Press to activate the Sleep Timer function and the duration which the receiver turns off automatically (page 68).
17 <b>DIMMER</b>	Press to change the brightness of the display (page 51).
18 <b>MEMORY/ENTER</b>	Press to store a station or enter the selection when selecting the settings (page 31).
19 <b>TUNING +/-</b>	Turn to scan a station (page 58, 61).
20 <b>VIDEO 3 IN/PORTABLE AV IN jacks</b>	To connect a camcorder or video game (page 27, 37).
21 <b>AUTO CAL MIC jack</b>	Connects to the supplied optimizer microphone for the Auto Calibration function (page 32).
22 <b>PHONES jack</b>	Connects to a headphone (page 74).

6<sup>66</sup>

#### About the indicators on the display

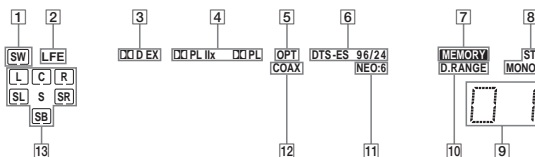

Name	Function
1 <b>SW</b>	Lights up when the audio signal is output from the SUB WOOFER jack.
2 <b>LFE</b>	Lights up when the disc being played back contains an LFE (Low Frequency Effect) channel and the LFE channel signal is actually being reproduced.
3 <b>D (EX)</b>	"D" lights up when Dolby Digital signals are input. "EX" lights up when Dolby Digital Surround EX signals are decoded. <b>Note</b> When playing a Dolby Digital format disc, be sure that you have made digital connections and that INPUT MODE is not set to "ANALOG" (page 62).
4 <b>PL (II/IX)</b>	"PL" lights up when the receiver applies Pro Logic processing to 2 channel signals. "II" lights up when the Pro Logic II Movie/Music/Game decoder is activated. "IX" lights up when the Pro Logic IIx Movie/Music/Game decoder is activated. <b>Note</b> Dolby Pro Logic IIx decoding does not function for DTS format signals or for signals with a sampling frequency of more than 48 kHz.

Name	Function
5 <b>OPT</b>	Lights up when INPUT MODE is set to "AUTO IN" and the source signal is a digital signal being input through the OPTICAL jack, or when INPUT MODE is set to "OPT IN" (page 62).
6 <b>DTS (-ES/96/24)</b>	"DTS" lights up when the receiver is decoding DTS signals. "DTS-ES" lights up when the receiver is decoding DTS-ES signals. "DTS 96/24" lights up when the receiver is decoding DTS 96 kHz/24 bit signals. <b>Note</b> When playing a DTS format disc, be sure that you have made digital connections and that INPUT MODE is not set to "ANALOG" (page 62).
7 <b>MEMORY</b>	Lights up when a memory function, such as Preset Memory (page 60), etc., is activated.
8 <b>Tuner indicators</b>	Lights up when using the receiver to tune in radio stations (page 58), etc.
9 <b>Preset station indicators</b>	Lights up when using the receiver to tune in radio stations you have preset. For details on presetting radio stations, see page 60.
10 <b>D.RANGE</b>	Lights up when dynamic range compression is activated (page 44).

continued

7<sup>66</sup>

Name	Function
11 <b>NEO:6</b>	Lights up when DTS Neo 6 Cinema/Music decoder is activated (page 53).
12 <b>COAX</b>	Lights up when INPUT MODE is set to "AUTO IN" and the source signal is a digital signal being input through the COAXIAL jack, or when INPUT MODE is set to "COAX IN" (page 62).
13 <b>Playback channel indicators</b>	The letters (L, C, R, etc.) indicate the channels being played back. The boxes around the letters vary to show how the receiver downmixes the source sound. L Front Left R Front Right C Center (monaural) SL Surround Left SR Surround Right S Surround (monaural or the surround components obtained by Pro Logic processing) SB Surround back (the surround back components obtained by 6.1 channel decoding) <b>Example:</b> Recording format (Front/ Surround) 3/2.1 Sound Field A.F.D. AUTO

8<sup>66</sup>

**Rear panel**

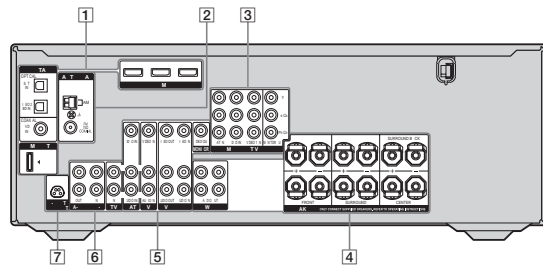

Getting Started

**1 DIGITAL INPUT/OUTPUT section**

	<b>OPTICAL IN jack</b>	Connects to a DVD player, etc. The COAXIAL jack provides a better quality of loud sound (page 24, 26).
	<b>COAXIAL IN jack</b>	
	<b>HDMI IN/OUT jack<sup>a)</sup></b>	Connects to a DVD player, etc. The image and the sound are output to a TV or a projector (page 21).
	<b>DMPORT jack<sup>b)</sup></b>	Connects to a DIGITAL MEDIA PORT adapter (page 64).

**2 ANTENNA section**

	<b>FM ANTENNA jack</b>	Connects to the FM wire antenna supplied with this receiver (page 29).
	<b>AM ANTENNA terminals</b>	Connects to the AM loop antenna supplied with this receiver (page 29).

**3 COMPONENT VIDEO INPUT/OUTPUT section**

	<b>Green (Y) VIDEO INPUT/OUTPUT jack<sup>a)</sup></b>	Connects to a DVD player, TV, a satellite tuner, etc. You can enjoy high quality image (page 23, 24, 26).
	<b>Blue (Pb/Cb) VIDEO INPUT/OUTPUT jack<sup>a)</sup></b>	
	<b>Red (Pr/Cr) VIDEO INPUT/OUTPUT jack<sup>a)</sup></b>	

**4 SPEAKER section**

	<b>SPEAKER terminals</b>	Connects to the speakers (page 17).
	<b>SUBWOOFER jack</b>	Connects to the sub woofers (page 17).

**5 VIDEO/AUDIO INPUT/OUTPUT section**

	<b>White (L) VIDEO/AUDIO INPUT/OUTPUT jack</b>	Connects the video and audio jacks of a VCR, DVD player, etc. (page 23, 24, 26, 27).
	<b>Red (R) VIDEO/AUDIO INPUT/OUTPUT jack<sup>a)</sup></b>	
	<b>Yellow VIDEO INPUT/OUTPUT jack<sup>a)</sup></b>	

**6 AUDIO INPUT/OUTPUT section**

	<b>White (L) AUDIO IN/OUT jack</b>	Connects to an Super Audio CD player or CD recorder, etc. (page 27).
	<b>Red (R) AUDIO IN/OUT jack</b>	

**7 D-LIGHT SYNC OUT section**

	<b>D-LIGHT SYNC OUT jack</b>	Connects to a lighting device (page 28).
--	------------------------------	--

<sup>a)</sup>You can watch the selected input image when you connect the HDMI OUT or MONITOR OUT jack to a TV (page 23).

<sup>b)</sup>Models of area code SP, AU only.

continued 9 GB

10 GB

**Remote commander**

You can use the supplied remote RM-AAU013 (models of area code E51, MX, AR only) or RM-AAU015 (models of area code AUS, MY, SP, TH only) to operate the receiver and to control the Sony audio/video components that the remote is assigned to operate. For details, see "Changing button assignments" (page 69).

Getting Started

**RM-AAU013 (Models of area code E51, MX, AR only)**      **RM-AAU015 (Models of area code AUS, MY, SP, TH only)**

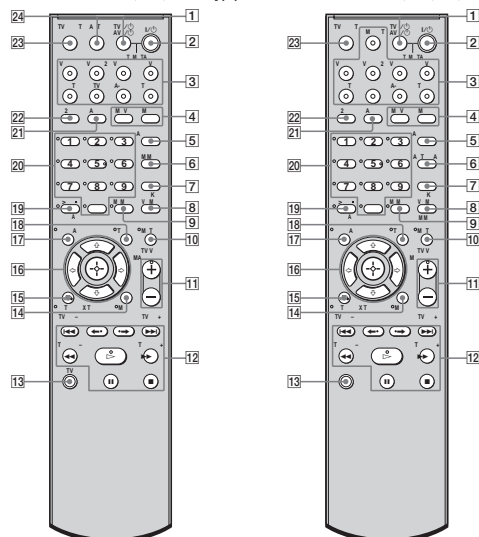

**Name      Function**

<b>1 TV I/O (on/standby)</b>	Press TV I/O and TV (13) at the same time to turn the TV on or off.
<b>AV I/O (on/standby)</b>	Press to turn on or off the Sony audio/video components that the remote is assigned to operate. If you press I/O (2) at the same time, it will turn off the receiver and other components (SYSTEM STANDBY). <b>Note</b> The function of the AV I/O switch changes automatically each time you press the input buttons (13).
<b>2 I/O (on/standby)</b>	Press to turn the receiver on or off. To turn off all components, press I/O and AV I/O (1) at the same time (SYSTEM STANDBY).
<b>3 Input buttons</b>	Press one of the buttons to select the component you want to use. When you press any of the input buttons, the receiver turns on. The buttons are factory assigned to control Sony components as follows. You can change the button assignments following the steps in "Changing button assignments" on page 69.

Button	Assigned Sony component
VIDEO 1	VCR (VTR mode 3)
VIDEO 2	VCR (VTR mode 1)
VIDEO 3	Not assigned
DVD	DVD player
SAT	Digital Satellite Receiver
TV	TV
SA-CD/CD	Super Audio CD/CD player
TUNER	Built-in tuner
DMPORT	DIGITAL MEDIA PORT adapter (RM-AAU015 only)

**Name      Function**

<b>4 MOVIE</b>	Press to select sound fields (MOVIE).
<b>MUSIC</b>	Press to select sound fields (MUSIC).
<b>5 AMP MENU</b>	Press to display the menu of the receiver. Then, use ▲, ▼, ◀, ▶ and (16) to perform menu operations.
<b>6 FM MODE (RM-AAU013 only)</b>	Press to select the FM monaural or stereo reception.
<b>AUTO CAL (RM-AAU015 only)</b>	Press to activate the Auto Calibration function (page 33).
<b>7 D.TUNING</b>	Press to enter direct tuning mode.
<b>D.SKIP</b>	Press to skip a disc when using a multi-disc changer.
<b>8 DVD MENU</b>	Press to display the menu of the DVD player on the TV screen. Then, use ▲, ▼, ◀, ▶ and (16) to perform menu operations.
<b>FM MODE (RM-AAU015 only)</b>	Press to select the FM monaural or stereo reception.
<b>9 ENTER</b>	Press to enter the value after selecting a channel, disc or track using the numeric buttons of the TV, VCR or satellite tuner.
<b>MEMORY</b>	Press to store a station.
<b>10 MUTING</b>	Press to activate the muting function. Press MUTING and TV (13) at the same time to activate the TV's muting function.
<b>11 TV VOL +/-</b>	Press TV VOL +/- and TV (13) at the same time to adjust the TV volume level.
<b>MASTER VOL +/-</b>	Press to adjust the volume level of all speakers at the same time.

continued 11 GB

12 GB

Name	Function
<b>12 TV CH +/-</b>	Press TV CH +/- and TV (13) at the same time to select preset TV channels.
<b>PRESET +/-</b>	Press to select – preset stations. – preset channels of the VCR or satellite tuner.
<b>◀◀/▶▶<sup>b)</sup></b>	Press to skip a track of the CD player, DVD player or Blu-ray disc player.
<b>REPLAY ←/ ADVANCE →</b>	Press to replay the previous scene or fast forward the current scene of the VCR, DVD player or Blu-ray disc player.
<b>◀◀/▶▶<sup>b)</sup></b>	Press to – search tracks in the forward/reverse direction of the DVD player. – start fast forward/rewind of the VCR, CD player or Blu-ray disc player.
<b>TUNING +/-</b>	Press to scan a station.
<b>▷<sup>a)b)</sup></b>	Press to start playback of the VCR, CD player, DVD player or Blu-ray disc player.
<b>⏸<sup>b)</sup></b>	Press to pause playback or recording of the VCR, CD player, DVD player or Blu-ray disc player. (Also starts recording with components in recording standby.)
<b>■<sup>b)</sup></b>	Press to stop playback of the VCR, CD player, DVD player or Blu-ray disc player.
<b>13 TV</b>	Press TV and the button you want at the same time to activate the buttons with orange printing.
<b>14 MENU</b>	Press to display the menu of the VCR, DVD player, satellite tuner or Blu-ray disc player on the TV screen. Press MENU and TV (13) at the same time to display the TV's menu. Then, use ▲, ▼, ◀, ▶ and ⏺ (16) to perform menu operations.

Name	Function
<b>15 RETURN/EXIT ⏺</b>	Press to – return to the previous menu. – exit the menu while the menu or on-screen guide of the VCR, DVD player, satellite tuner or Blu-ray disc player is displayed on the TV screen. Press RETURN/EXIT and TV (13) at the same time to return to the previous menu or exit the TV's menu while the menu is displayed on the TV screen.
<b>16 ⏺</b>	After pressing AMP MENU (5), DVD MENU (8) or MENU (14), press ▲, ▼, ◀, ▶ or ⏺ to select the settings. Then, press ⏺ to enter the selection for DVD MENU or MENU. Press ⏺ also to enter the selection of the receiver, VCR, satellite tuner, CD player, DVD player or Blu-ray disc player.
<b>17 DISPLAY</b>	Press to select information displayed on the TV screen of the VCR, satellite tuner, CD player, DVD player or Blu-ray disc player. Press DISPLAY and TV (13) at the same time to select TV information displayed on the TV screen.
<b>18 TOOLS</b>	Press to display options applicable to the entire disc (e.g. disc protection), recorder (e.g. audio settings during recording), or multiple items on a list menu (e.g. erasing multiple titles). Press TOOLS and TV (13) at the same time to display options applicable to the TV.

Getting Started

Name	Function
<b>19 &gt;10/</b>	Press to select – track numbers over 10 of the VCR, satellite tuner or CD player. – channel numbers of the Digital CATV terminal.
<b>-/-</b>	Press -/- and TV (13) at the same time to select the channel entry mode, either one or two digits of the TV.
<b>CLEAR</b>	Press to clear a mistake when you press the incorrect numeric button.
<b>20 Numeric buttons (number 5<sup>a)</sup>)</b>	Press to – preset/tune to preset stations. – select track numbers of the CD player, DVD player or Blu-ray disc player. Press 0/10 to select track number 10. – select channel numbers of the VCR or satellite tuner. Press the numeric buttons and TV (13) at the same time to select the TV channels.
<b>21 A.F.D.</b>	Press to select A.F.D. mode.
<b>22 2CH</b>	Press to select 2CH STEREO mode.
<b>23 TV INPUT</b>	Press TV INPUT and TV (13) at the same time to select the input signal (TV input or video input).
<b>SLEEP</b>	Press to activate the Sleep Timer function and the duration which the receiver turns off automatically.
<b>24 AUTO CAL (RM-AAU013 only)</b>	Press to activate the Auto Calibration function.

<sup>a)</sup>The number 5, MASTER VOL +, TV VOL + and ▷ buttons have tactile dots. Use the tactile dots as references when operating the receiver.

<sup>b)</sup>This button is also available for DIGITAL MEDIA PORT adapter operation. For details on the function of the button, see the operating instructions supplied with the DIGITAL MEDIA PORT adapter.

## Notes

- The VIDEO 3 button on the remote is not available for receiver operation.
- Some functions explained in this section may not work depending on the model.
- The above explanation is intended to serve as an example only. Therefore, depending on the component, the above operation may not be possible or may operate differently than described.

continued

13<sup>68</sup>14<sup>68</sup>

## SECTION 2 DISASSEMBLY

**Note :** This set can be disassemble according to the following sequence.

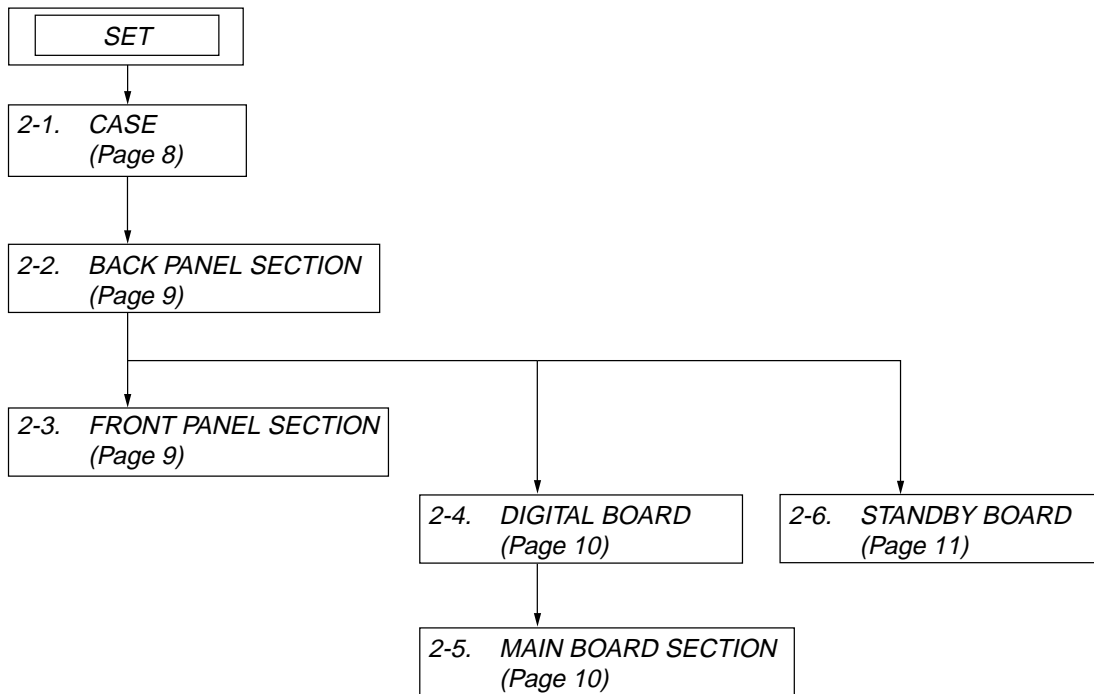

**Note :** Follow the disassembly procedure in the numerical order given.

### 2-1. CASE

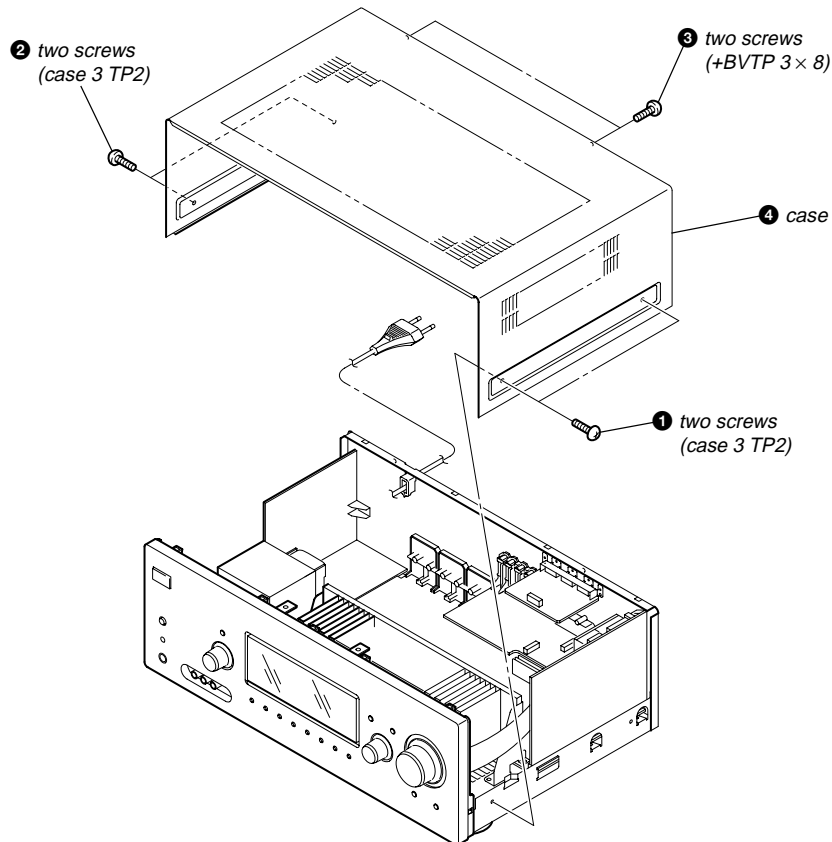



2-2. BACK PANEL SECTION

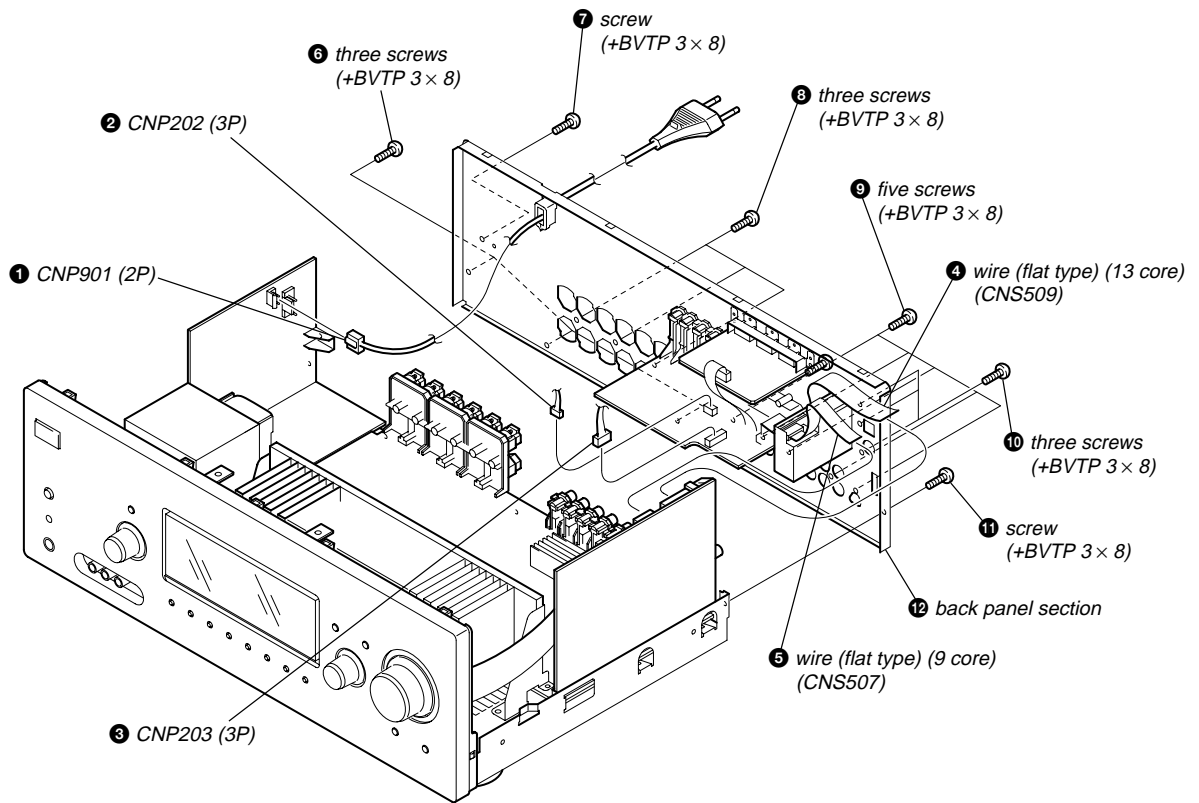

2-3. FRONT PANEL SECTION

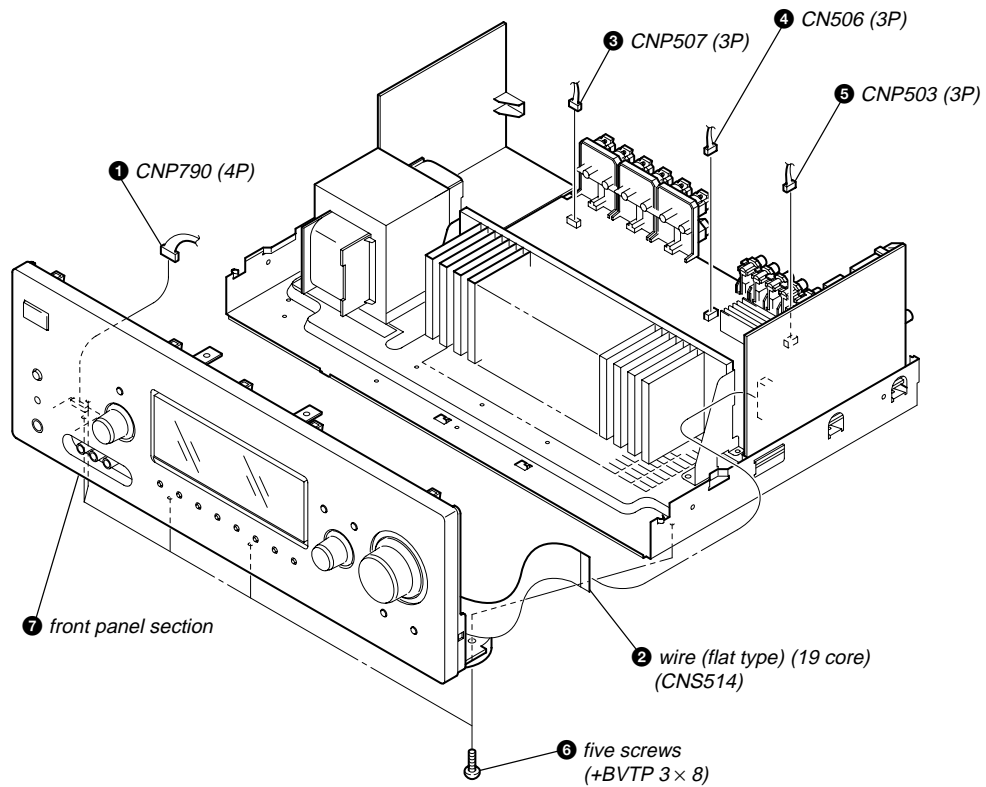

2-4. DIGITAL BOARD

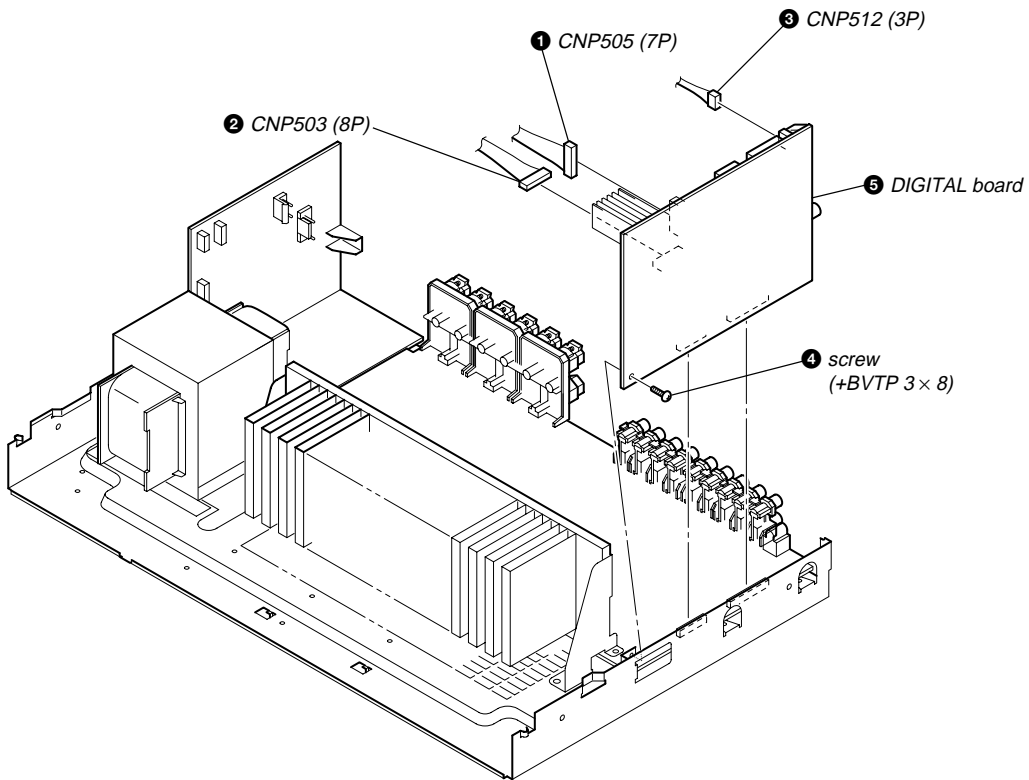

2-5. MAIN BOARD SECTION

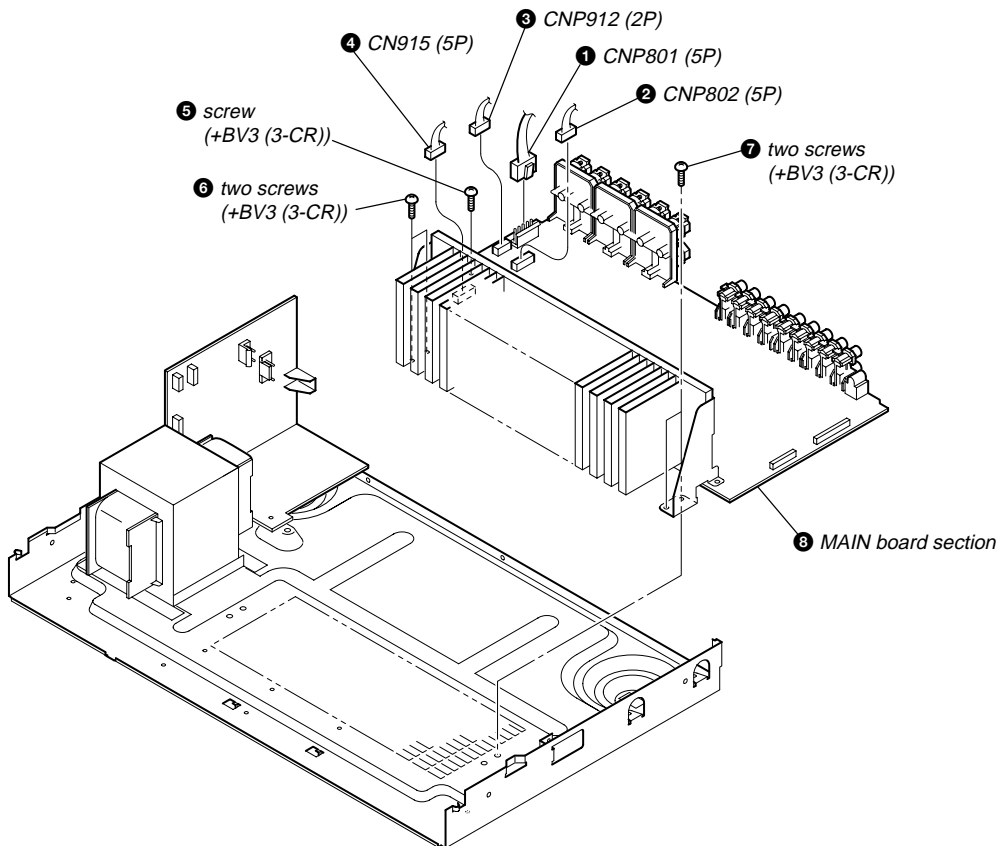

2-6. STANDBY BOARD

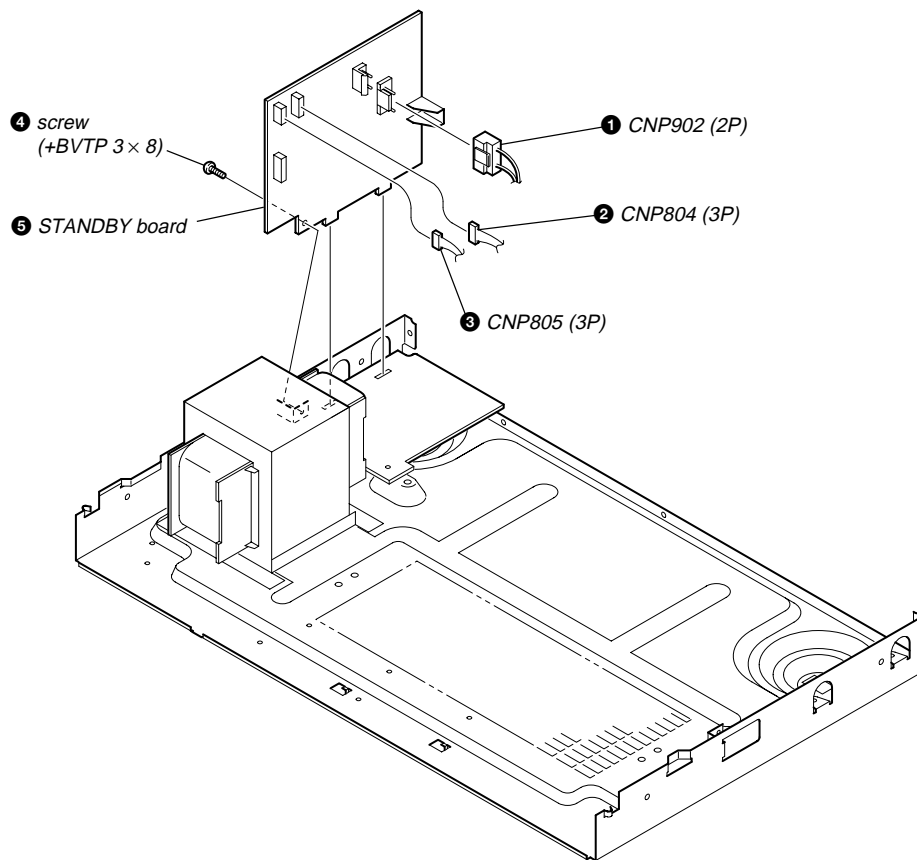

## SECTION 3 TEST MODE

### AM CHANNEL STEP 9 kHz/10 kHz SELECTION MODE (E51 model only)

\* Either the 9 kHz step or 10 kHz step can be selected for the AM channel step.

\* Procedure:

Turn the **[INPUT SELECTOR]** control to set AM and press the **[I/⏻]** button to turn off the main power.

While depressing the **[TUNING MODE]** button, press the **[I/⏻]** button to turn on the main power.

Either the message “9k STEP” or “10k STEP” appears for a moment and select the desired step.

### VACUUM FLUORESCENT DISPLAY TEST MODE

\* All fluorescent segments are tested.

When this test is activated, all segments light on at the same time, then each segment lights on one after another.

\* Procedure:

While depressing the **[DIMMER]** and the **[DISPLAY]** buttons simultaneously, press the **[I/⏻]** button to turn on the main power.

1. ALL segments light on.

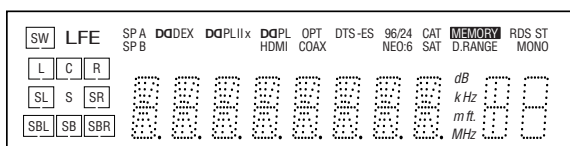

**[MULTI CHANNEL DECODING]** LED light on.

2. Turn the **[INPUT SELECTOR]** control, confirm display.

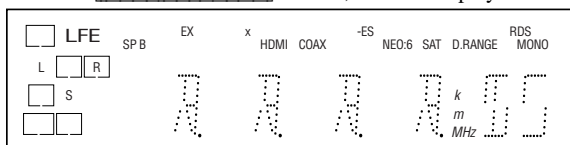

**[MULTI CHANNEL DECODING]** LED light off.

3. Turn the **[INPUT SELECTOR]** control, confirm display.

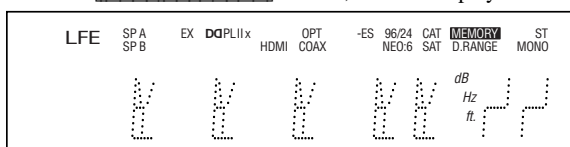

**[MULTI CHANNEL DECODING]** LED light on.

4. Turn the **[INPUT SELECTOR]** control, all segments and LED light off.

### SOUND FIELD CLEAR MODE

\* The preset sound field is cleared when this mode is activated.

Use this mode before returning the product to clients upon completion of repair.

\* Procedure:

While depressing the **[2CH]** button, press the **[I/⏻]** button to turn on the main power.

The message “S.F. CLR.” appears for a moment and initialization is performed.

### SOFTWARE VERSION DISPLAY MODE

\* The software version is displayed.

\* Procedure:

While depressing the **[AUTO CAL]** and the **[DISPLAY]** buttons simultaneously, press the **[I/⏻]** button to turn on the main power.

The model name, destination and the software version are displayed for a moment.

### KEY CHECK MODE

\* Button check

\* Procedure:

While depressing the **[AUTO CAL]** and the **[2CH]** buttons simultaneously, press the **[I/⏻]** button to turn on the main power.

Either the message “REST 14” appears.

Every pressing of any button other than the **[I/⏻]** counts down the buttons. The buttons which are already counted once are not counted again. When all buttons are pressed “REST 00” appears.

### SWAP ALL MODE

\* The signal will be swap to all channel so that all speaker will have sound output.

\* Procedure:

1. While depressing the **[AUTO CAL]** and the **[A.F.D.]** buttons simultaneously, press the power **[I/⏻]** button to turn on the main power.
2. “SWP. ALL” appears. (No change while displayed.)

### SHIPMENT MODE

All preset contents are reset to the default setting.

\* Procedure:

1. While depressing the **[AUTO CAL]** and the **[MUSIC]** buttons simultaneously, press the power **[I/⏻]** button to turn on the main power.
2. “CLEARED” appears and switch off the set.

### DCAC FACTORY TEST MODE

DCAC Factory Test mode have two stages:

1. DCAC DSP Data Line Checking
2. DCAC board Checking

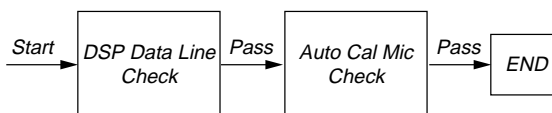

### Factory Test System Setup

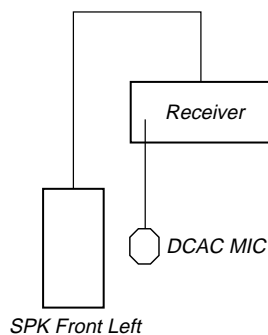

1. When power off:  
Press the three buttons **[MEMORY/ENTER]** + **[MOVIE]** + **[I/⏻]**. “DCAC□FTM” appears.  
Afterward, press the **[TUNING MODE]** to start DCAC factory test mode.

**SECTION 4**  
**FM TUNER CHECK****1. DCAC DSP Data Line Checking**

After press the [TUNING MODE], DCAC Factory test mode will start, below display will show:

“DCAC□□□x” x=1, 2, 3

If there is error happen, below display will show:

“ERR□SD0x” x=1 → D1501 or R1530 problem

x=2 → D1502 problem

x=3 → D1503 problem

**2. DCAC board Checking**

Connect front left speaker of the receiver and AUTO CAL microphone. Turn [MASTER VOLUME] jog, there will be test tone sound output from front left speaker, and the display will change accordingly.

“AD□-□xxx” xxx=0 to 255 (depends on loudness of test tone)

**FM AUTO STOP CHECK**

- (1) Turn on the set.
- (2) Input the following signal from Signal Generator to FM antenna input directly.

\* Carrier Frequency: A=87.5 MHz, B=98 MHz, C=108 MHz

Deviation : 75 kHz

Modulation : 1 kHz

ANT input : 35 dBu (EMF)

**(Note)**

Please use 75 ohm “coaxial cable” to connect SG and the set. You cannot use video cable for checking.

Please use SG whose output impedance is 75 ohm.

- (3) Set to FM tuner function and scan the input FM signal with automatic scanning.
- (4) Confirm that input Frequency of A, B and C are detected and automatic scanning stops.

The stop of automatic scanning means “The station signal is received in good condition.”

## SECTION 5 DIAGRAMS

### • Circuit Boards Location

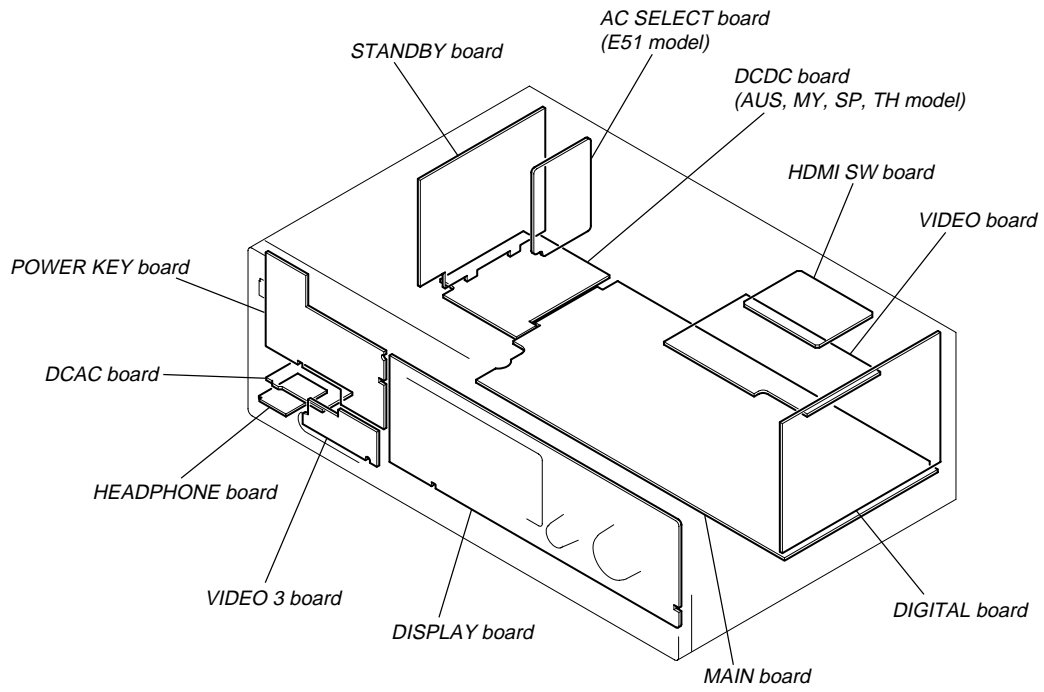

5-1. BLOCK DIAGRAM — TUNER/AUDIO SECTION —

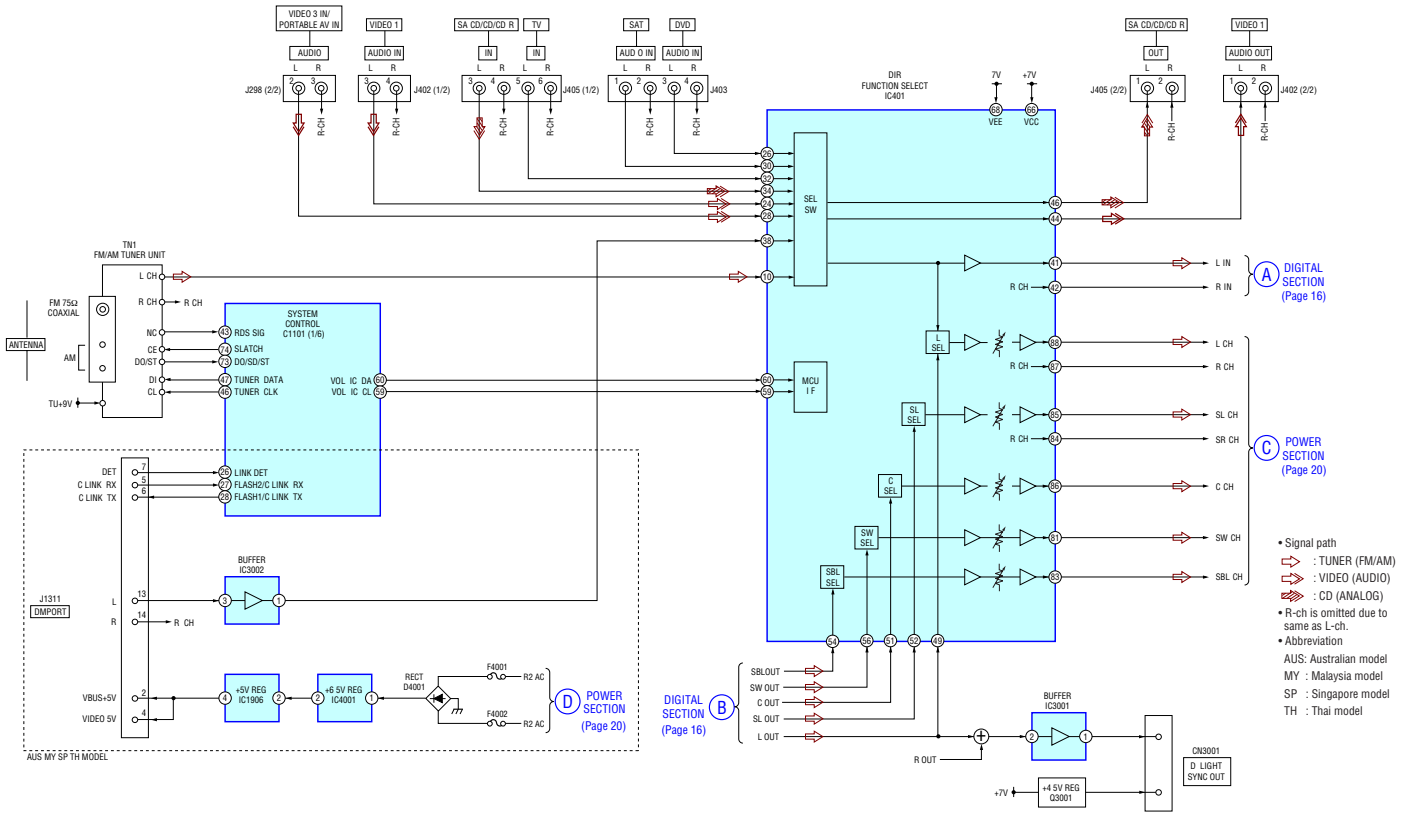

5-2. BLOCK DIAGRAM — DIGITAL SECTION —

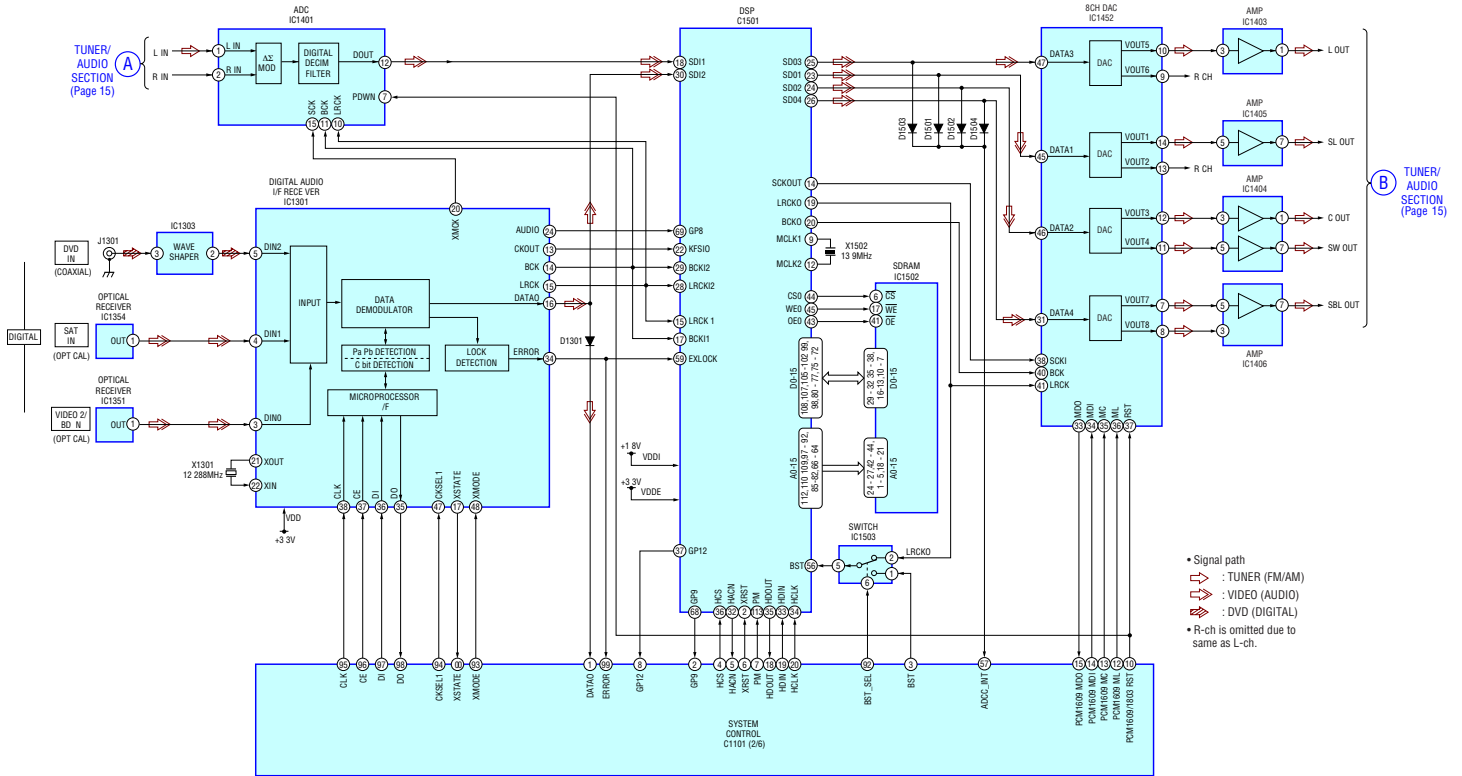

- Signal path
- ➡ : TUNER (FM/AM)
- ➡ : VIDEO (AUDIO)
- ➡ : DVD (DIGITAL)
- R-ch is omitted due to same as L-ch.



5-3. BLOCK DIAGRAM — VIDEO SECTION —

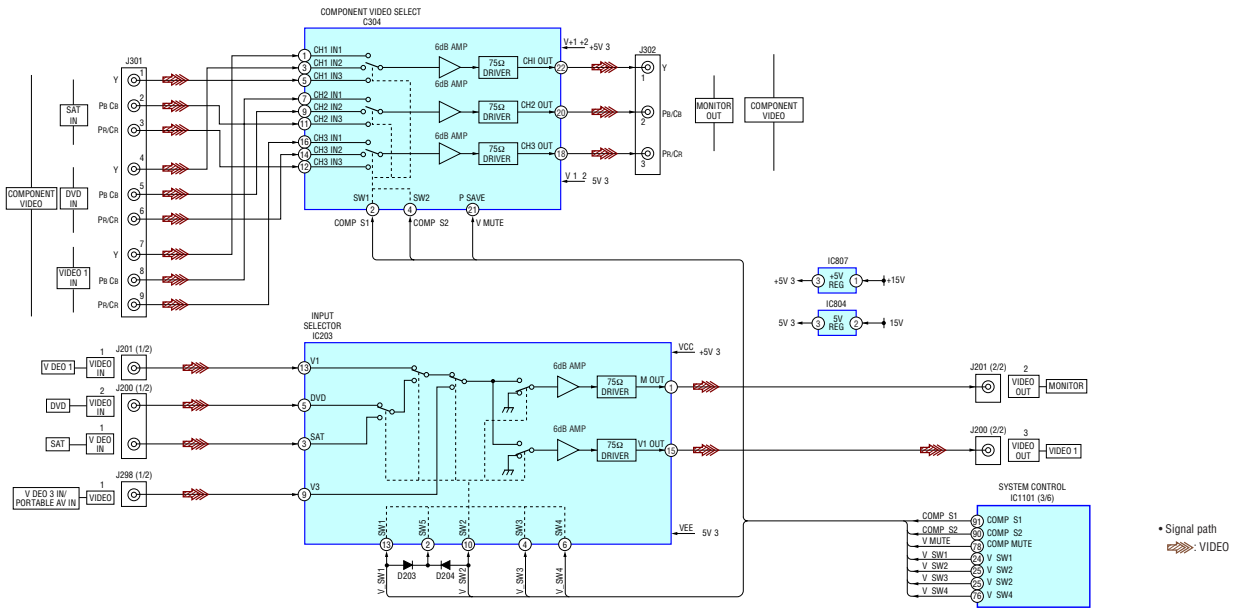

5-4. BLOCK DIAGRAM — HDMI SW SECTION —

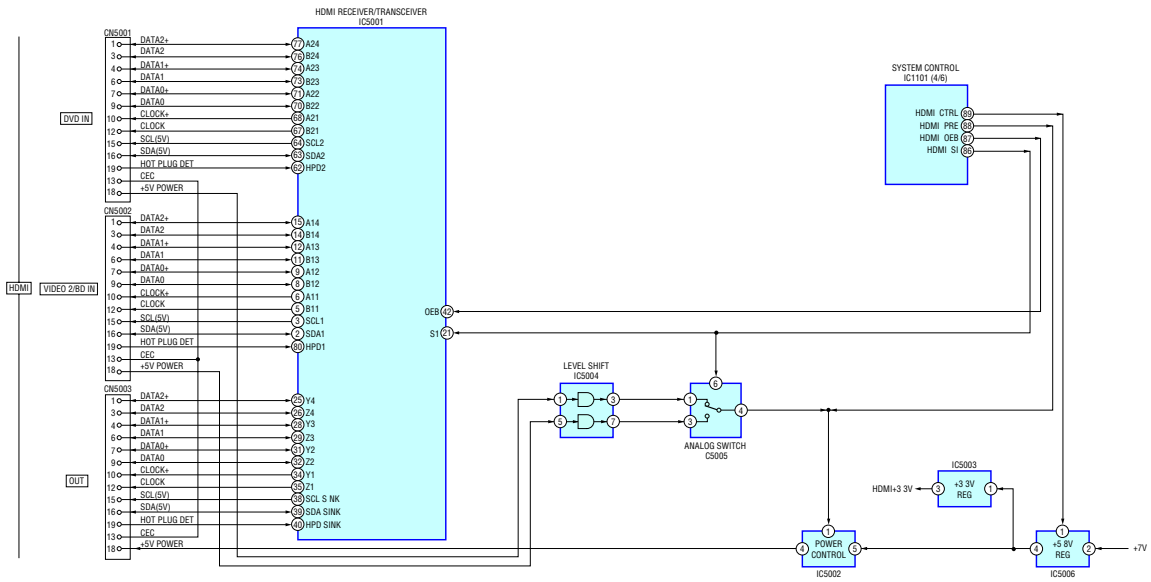

5-5. BLOCK DIAGRAM — KEY/DISPLAY SECTION —

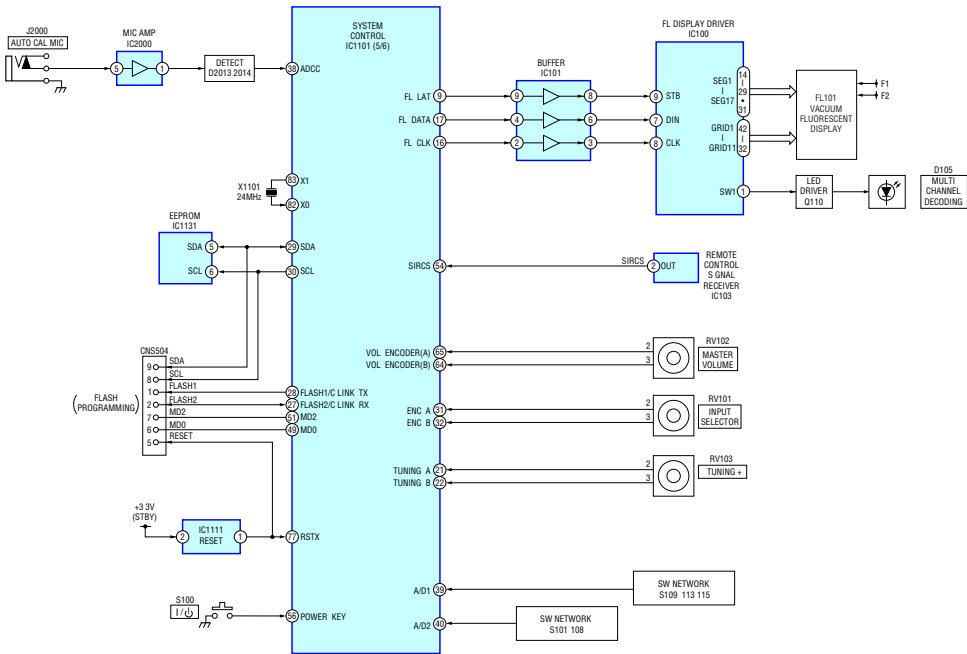

5-6. BLOCK DIAGRAM — POWER SECTION —

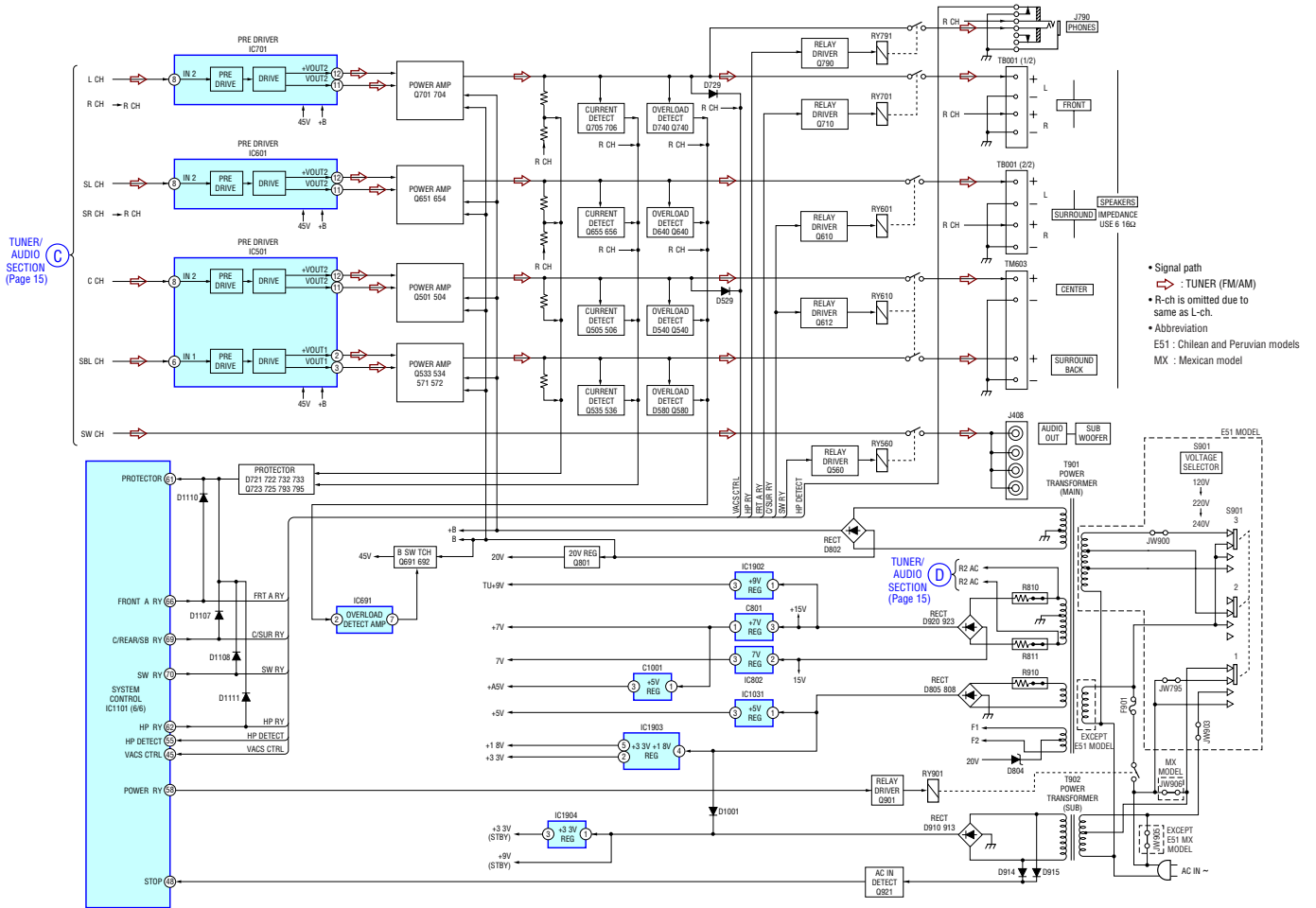

**THIS NOTE IS COMMON FOR PRINTED WIRING BOARDS AND SCHEMATIC DIAGRAMS.**  
(In addition to this, the necessary note is printed in each block.)

**for schematic diagram:**

- All capacitors are in  $\mu\text{F}$  unless otherwise noted. (p pF)
- 50 WV or less are not indicated except for electrolytics and tantalums.
- All resistors are in  $\Omega$  and  $\frac{1}{2}$  W or less unless otherwise specified.
- $\Delta$  internal component.
- $\frac{1}{2}$ W nonflammable resistor.
- $\frac{1}{2}$ W fusible resistor.
- $\frac{1}{2}$ W panel designation.

**Note:** The components identified by mark  $\Delta$  or dotted line with mark  $\Delta$  are critical for safety. Replace only with part number specified.

- $\frac{1}{2}$ W B+ Line.
- $\frac{1}{2}$ W B- Line.
- Voltage and waveforms are dc with respect to ground under no-signal (detuned) conditions.
- no mark FM
- Voltagess are taken with a VOM (Input impedance 10 M $\Omega$ ). Voltage variations may be noted due to normal production tolerances.
- Waveforms are taken with a oscilloscope. Voltage variations may be noted due to normal production tolerances.
- Circled numbers refer to waveforms.

**for printed wiring boards:**

- $\frac{1}{2}$ W parts extracted from the component side.
- $\Delta$  internal component.
- $\frac{1}{2}$ W Pattern from the side which enables seeing.

**Caution**

Pattern face side (Side B) Parts on the pattern face side seen from the pattern face are indicated.

Parts face side (Side A) Parts on the parts face side seen from the parts face are indicated.

**Abbreviation**

- AUS Australian model
- MY Malaysia model
- SP Singapore model
- TH Thai model
- E51 Chilean and Peruvian models
- MX Mexican model

**Signal path:**

- TUNER (FM/AM)
- VIDEO (AUDIO)
- VIDEO
- DVD (DIGITAL)
- CD (ANALOG)

**Abbreviation**

- AUS Australian model
- MY Malaysia model
- SP Singapore model
- TH Thai model
- AR Argentina model
- E51 Chilean and Peruvian models
- MX Mexican model

**Waveforms**  
— DIGITAL Board —

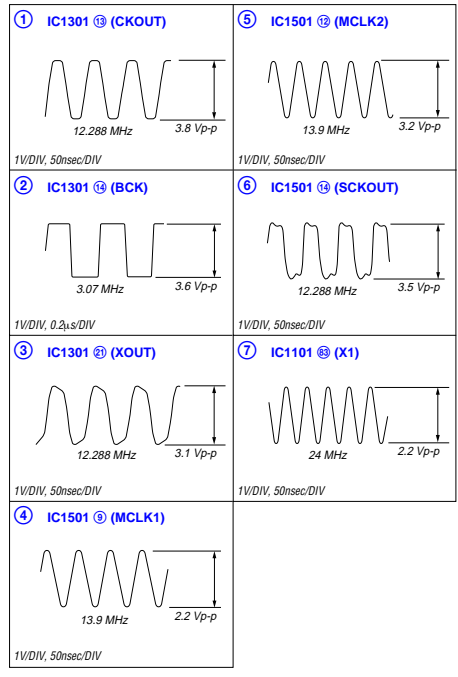

**STR-K1600**  
Ver. 1.1

5-7. PRINTED WIRING BOARDS — MAIN SECTION — • Refer to page 14 for Circuit Boards Location. **LF** : Uses unleaded solder.

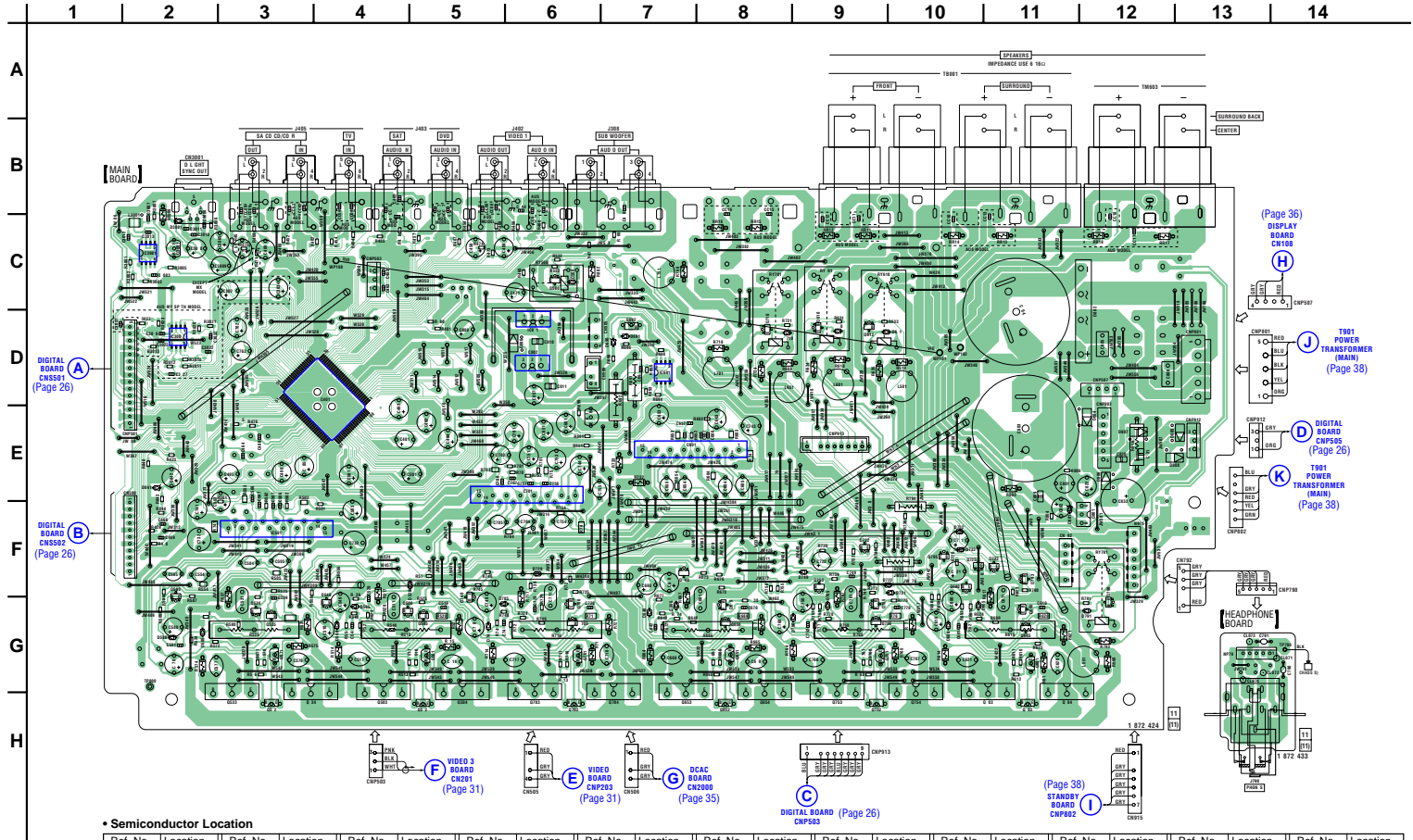

**• Semiconductor Location**

Ref. No.	Location	Ref. No.	Location	Ref. No.	Location	Ref. No.	Location	Ref. No.	Location	Ref. No.	Location	Ref. No.	Location	Ref. No.	Location	Ref. No.	Location
D505	G-4	D665	G-7	D733	F-10	D806	E-12	IC691	D-7	Q504	H-5	Q572	H-3	Q640	F-7	Q701	G-6
D529	F-4	D680	G-10	D740	G-5	D807	E-12	IC701	E-6	Q505	G-5	Q580	F-2	Q651	G-8	Q702	H-6
D540	G-4	D690	D-7	D749	F-9	D808	E-12	IC801	D-6	Q506	G-4	Q601	G-11	Q652	H-8	Q703	H-6
D560	C-6	D691	D-7	D750	G-9	D841	E-2	IC802	D-6	Q533	H-3	Q602	H-11	Q653	H-7	Q704	H-7
D580	G-2	D705	G-5	D765	G-9	D896	D-6	IC3001	C-2	Q534	H-3	Q603	H-11	Q654	H-8	Q705	G-6
D585	G-2	D710	D-8	D791	G-12	D3001	C-2	(IC3002)	D-2	Q535	G-3	Q604	H-11	Q655	G-8	Q706	G-6
D605	G-10	D721	F-10	D801	F-11					Q536	G-3	Q605	G-11	Q656	G-8	Q710	D-8
D610	D-9	D722	F-9	D802	D-12	IC401	D-4	Q501	G-5	Q540	G-4	Q606	G-11	Q680	F-10	Q722	F-9
D611	D-10	D729	F-6	D804	E-12	IC501	F-3	Q502	H-5	Q560	C-6	Q610	D-9	Q691	E-6	Q723	F-11
D640	G-7	D732	F-10	D805	E-12	IC601	E-7	Q503	H-4	Q571	G-3	Q612	D-9	Q692	D-7	Q725	F-10
																Q740	G-5
																Q750	F-9
																Q751	G-9
																Q752	H-9
																Q753	H-9
																Q754	H-10
																Q755	G-9
																Q756	G-9
																Q790	G-12
																Q793	F-11
																Q795	F-10
																Q801	F-12
																Q3001	C-2

5-8. SCHEMATIC DIAGRAM — MAIN SECTION (1/2) — • Refer to page 41 for IC Block Diagrams.

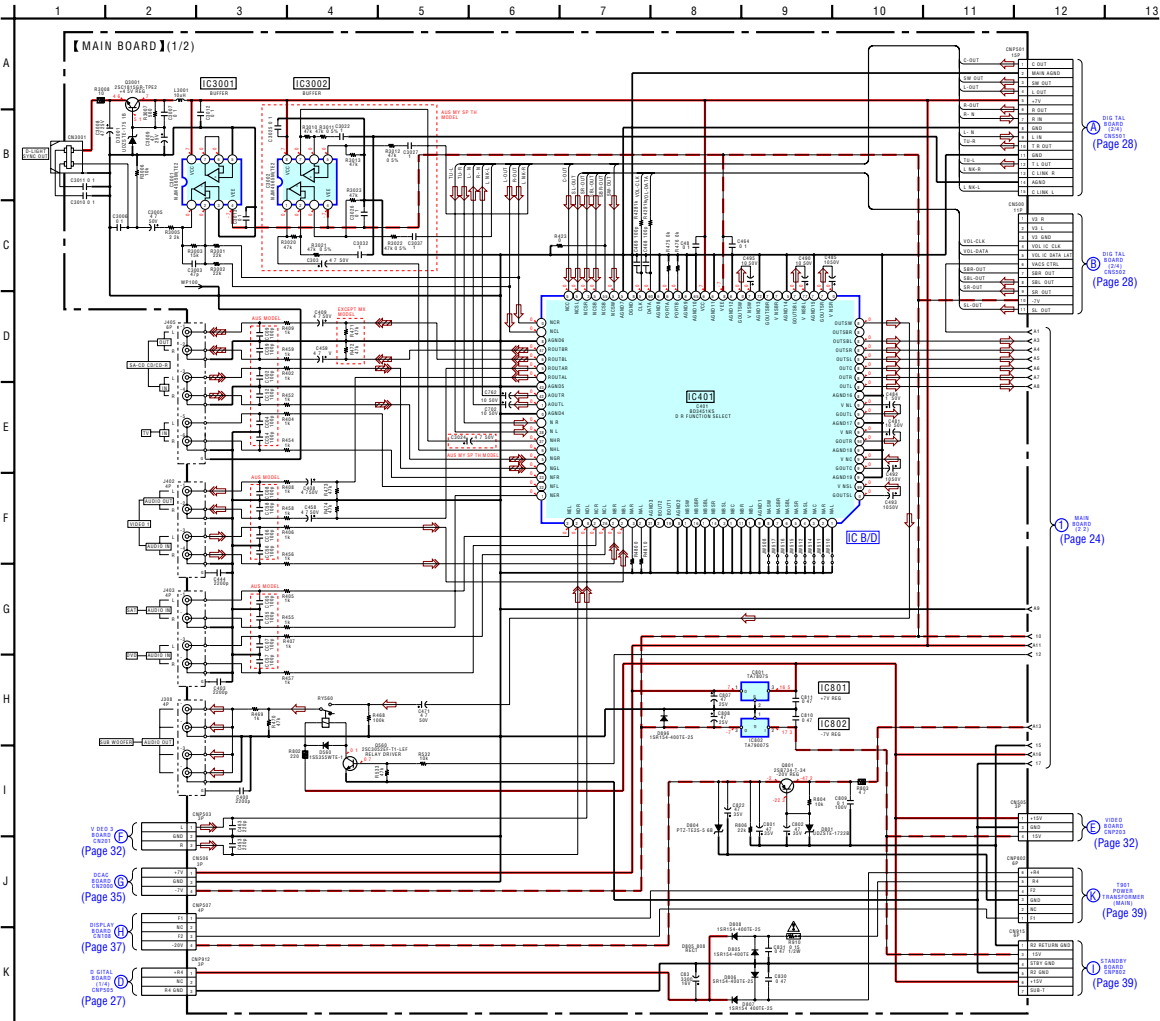

5-9. SCHEMATIC DIAGRAM — MAIN SECTION (2/2) — • Refer to page 41 for IC Block Diagrams.

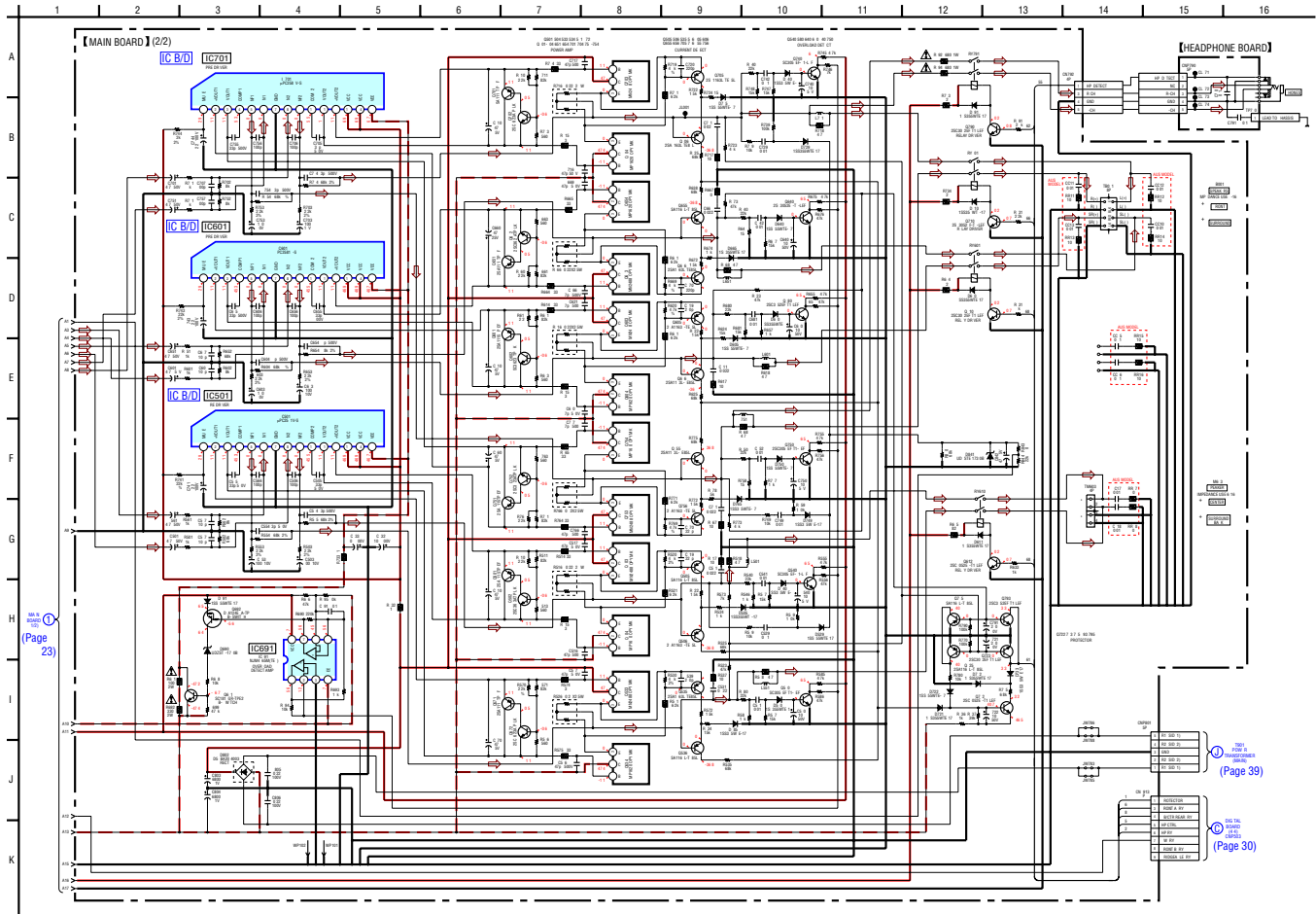



5-10. PRINTED WIRING BOARD — DIGITAL SECTION (1/2) — • Refer to page 14 for Circuit Boards Location.  : Uses unleaded solder.

14 | 13 | 12 | 11 | 10 | 9 | 8 | 7 | 6 | 5 | 4 | 3 | 2 | 1

A  
B  
C  
D  
E  
F  
G  
H  
I

【DIGITAL BOARD】(SIDE A)

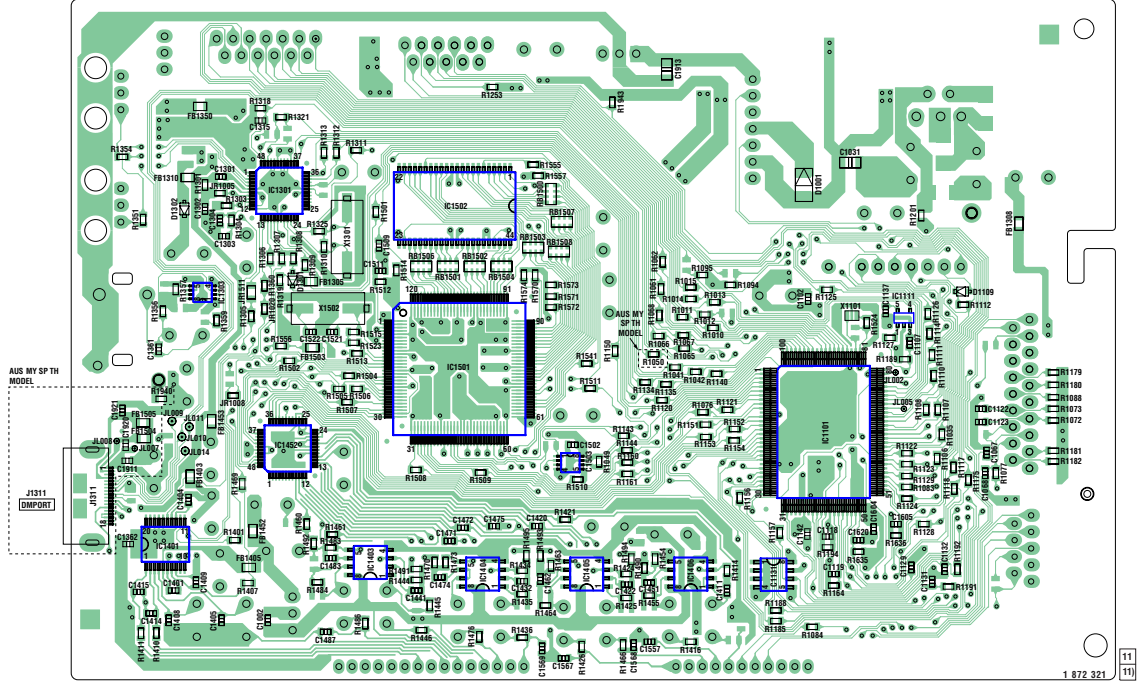

• Semiconductor Location (Side A)

Ref. No.	Location
D1001	D-6
D1109	E-4
D1301	E-11
D1302	D-12
IC1101	G-5
IC1111	E-5
IC1131	H-6
IC1301	D-11
IC1303	E-11
IC1401	H-12
IC1403	H-10
IC1404	H-9
IC1405	H-8
IC1406	H-7
IC1452	G-11
IC1501	F-9
IC1502	D-9
IC1503	G-8

5-11. PRINTED WIRING BOARD — DIGITAL SECTION (2/2) — • Refer to page 14 for Circuit Boards Location. **L** : Uses unleaded solder.

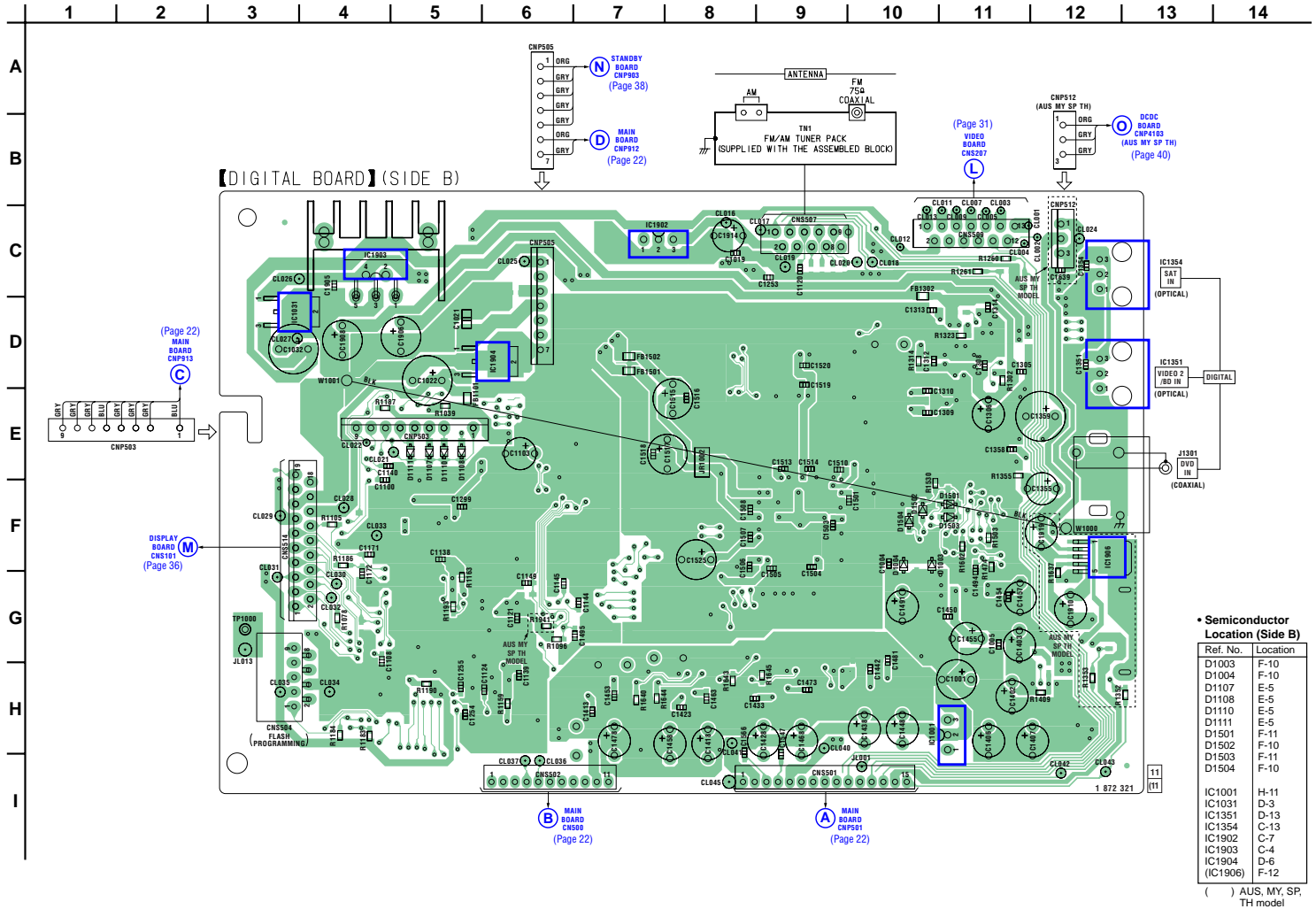

5-12. SCHEMATIC DIAGRAM — DIGITAL SECTION (1/4) — • Refer to page 21 for Waveforms and page 42 for IC Block Diagrams.

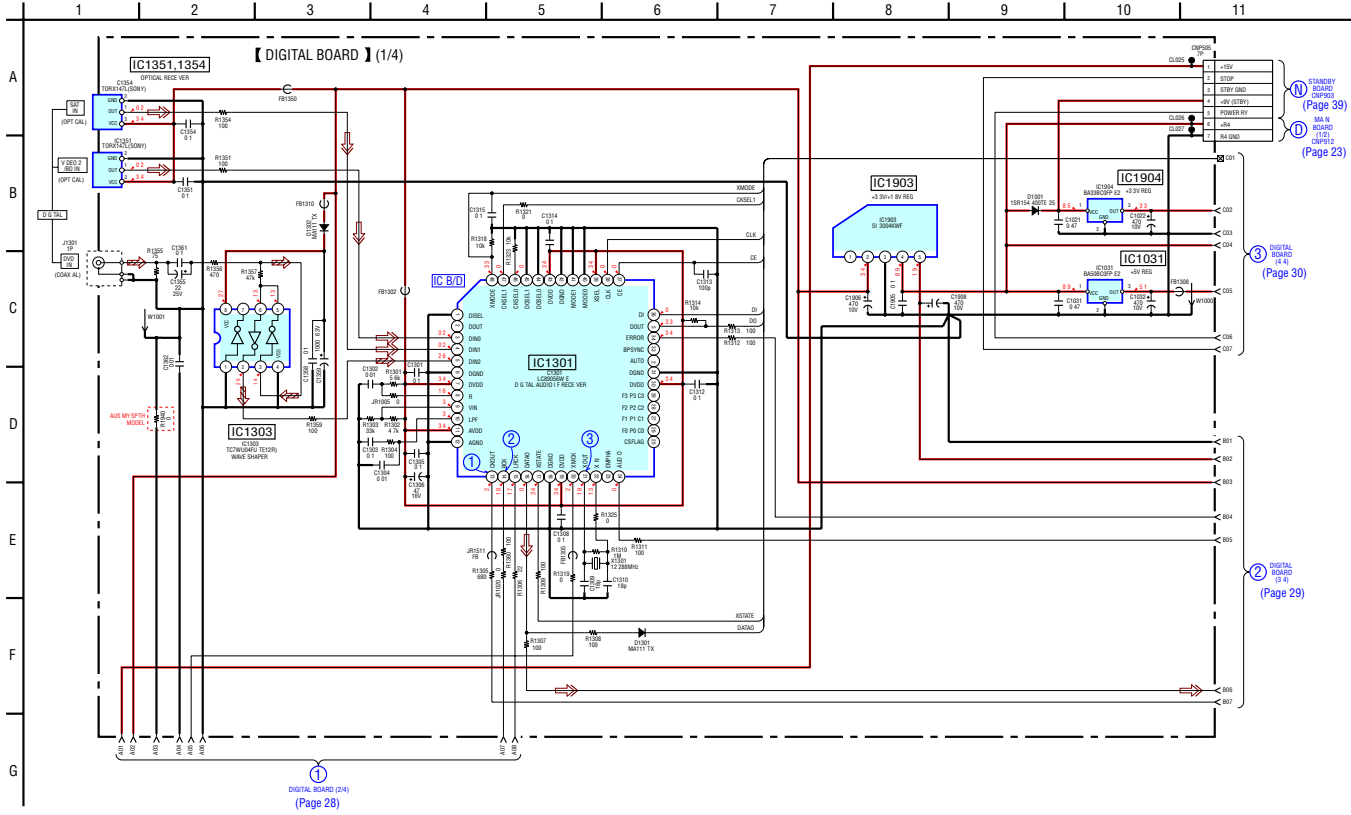

① STANDBY BOARD (Page 39)

② MAIN BOARD (Page 23)

③ DIGITAL BOARD (Page 30)

④ DIGITAL BOARD (Page 29)

① DIGITAL BOARD (1/4) (Page 28)

5-13. SCHEMATIC DIAGRAM — DIGITAL SECTION (2/4) — • Refer to page 42 for IC Block Diagrams.

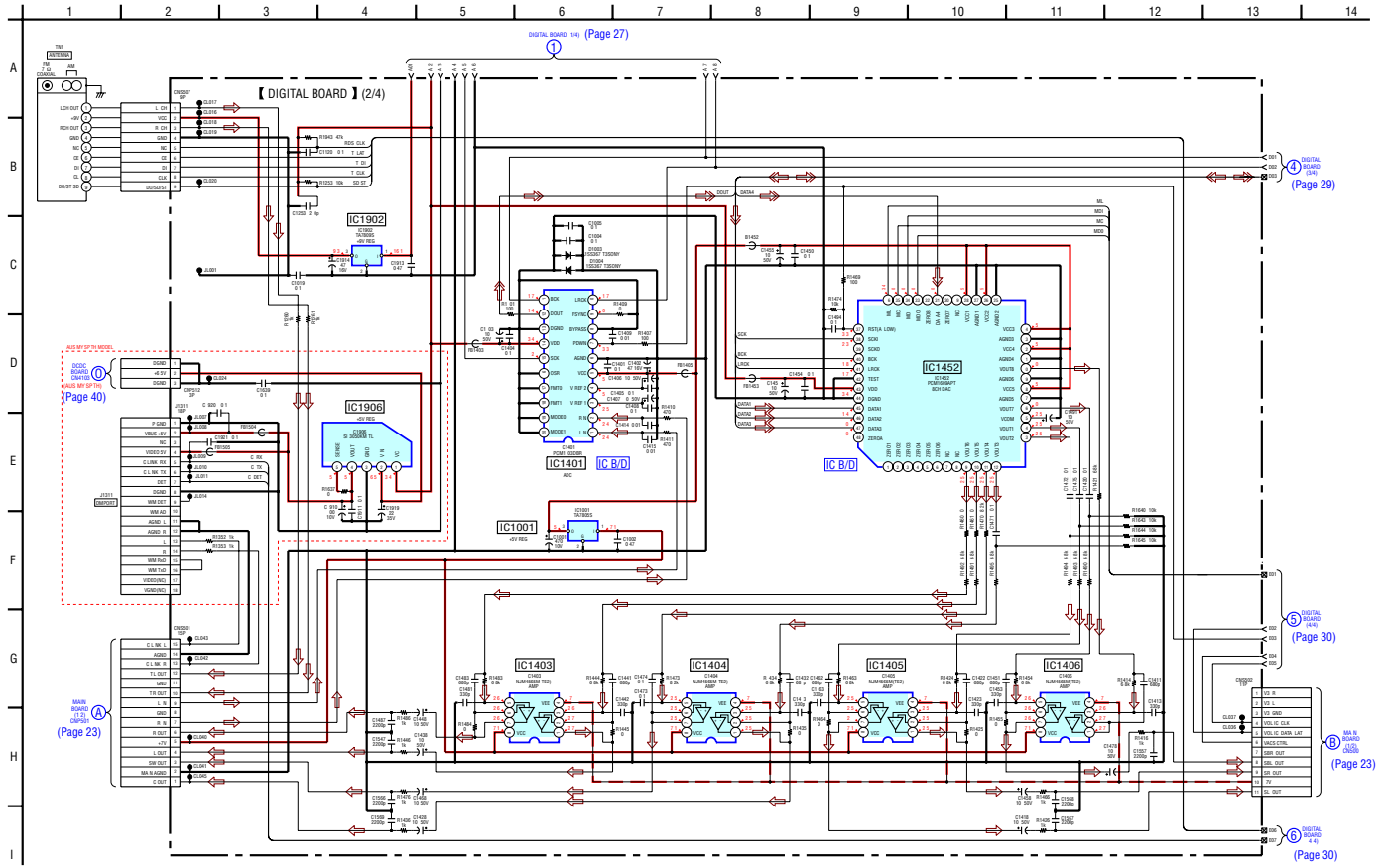

5-14. SCHEMATIC DIAGRAM — DIGITAL SECTION (3/4) — • Refer to page 21 for Waveforms and page 45 IC Pin Descriptions.

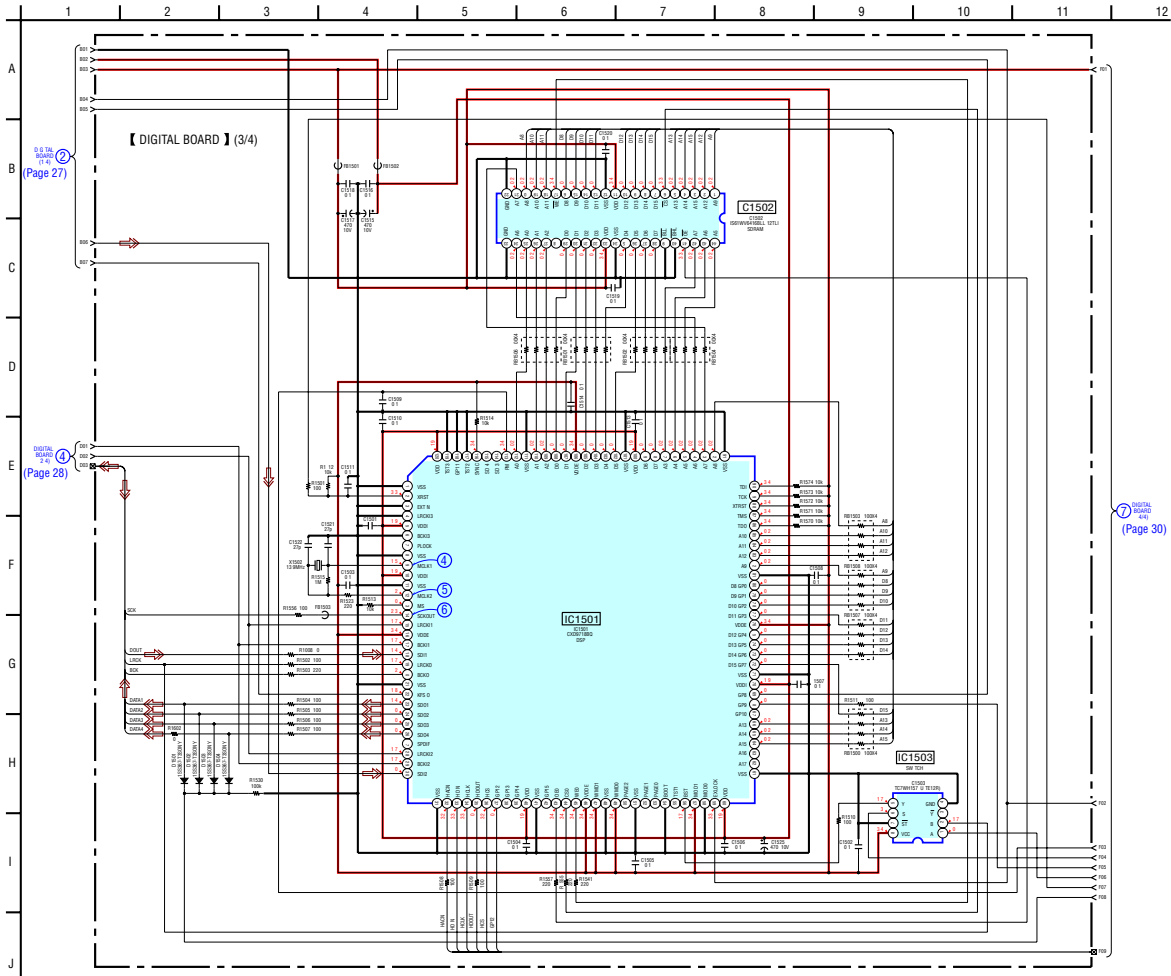

5-15. SCHEMATIC DIAGRAM — DIGITAL SECTION (4/4) — • Refer to page 21 for Waveforms and page 47 for IC Pin Descriptions.

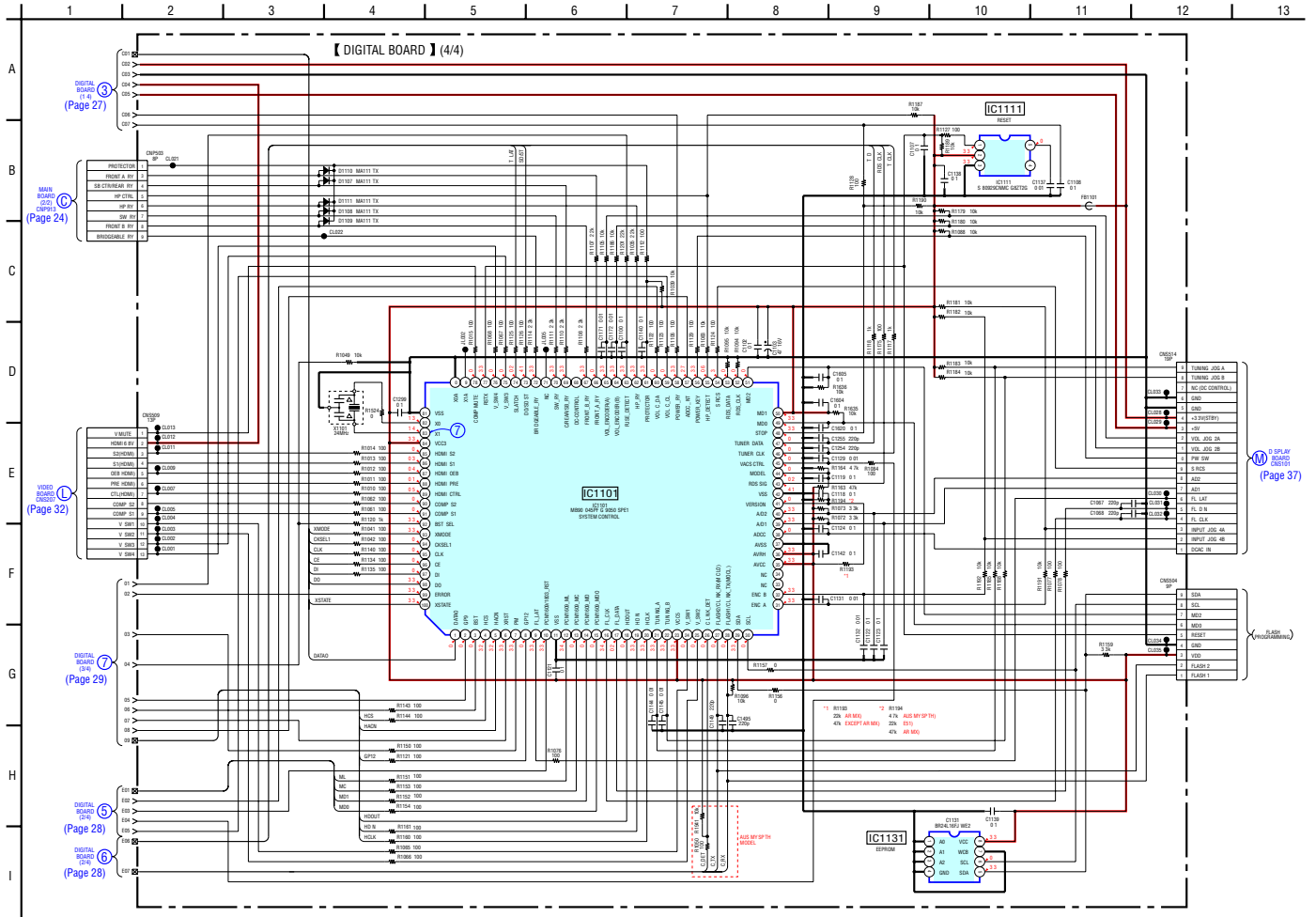

5-16. PRINTED WIRING BOARDS — VIDEO SECTION — • Refer to page 14 for Circuit Boards Location. **F** : Uses unleaded solder.

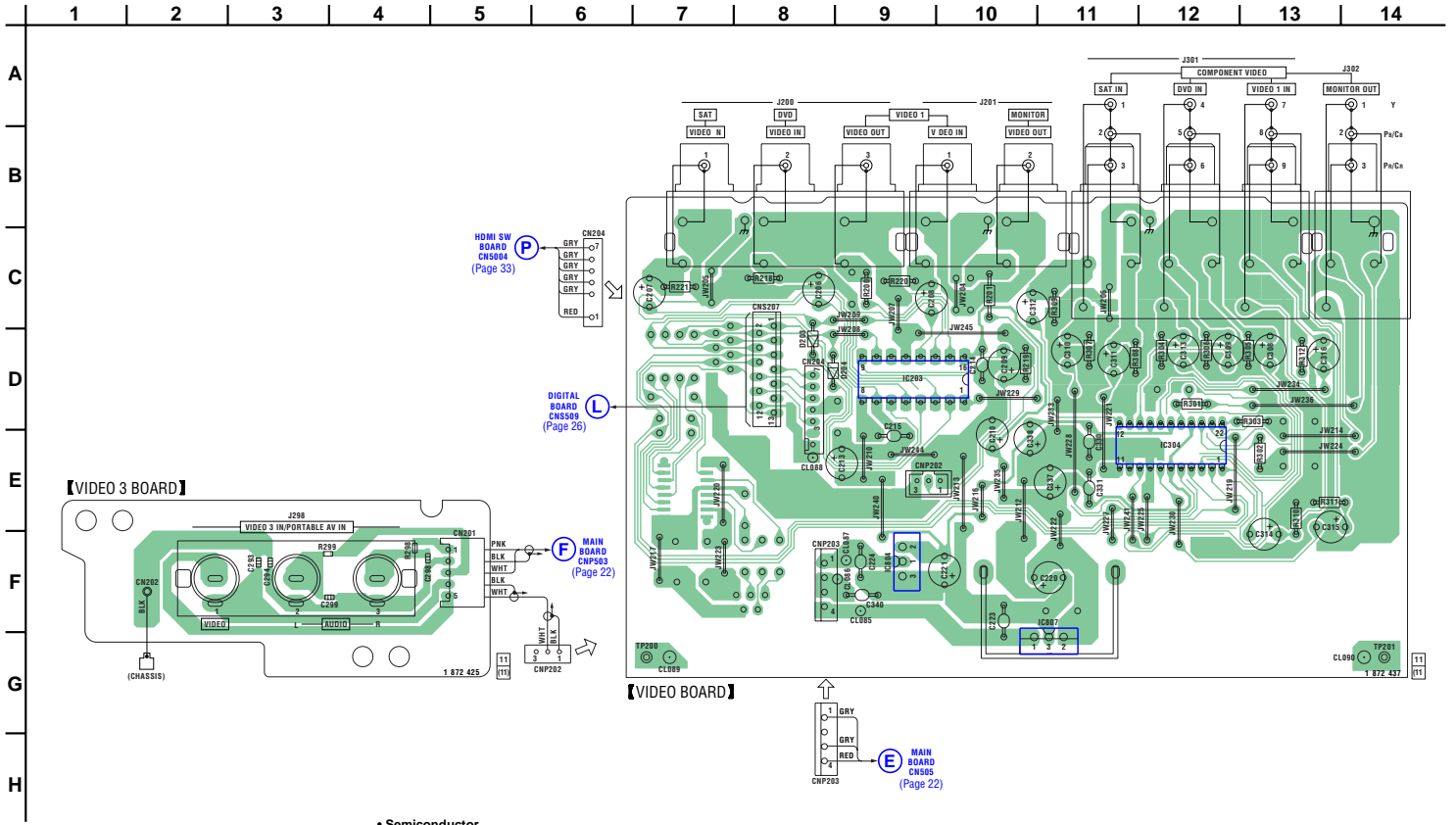

• Semiconductor Location

Ref. No.	Location
D203	D-8
D204	D-9
IC203	D-9
IC304	E-12
IC804	F-9
IC807	G-11

5-17. SCHEMATIC DIAGRAM — VIDEO SECTION — • Refer to page 43 for IC Block Diagrams.

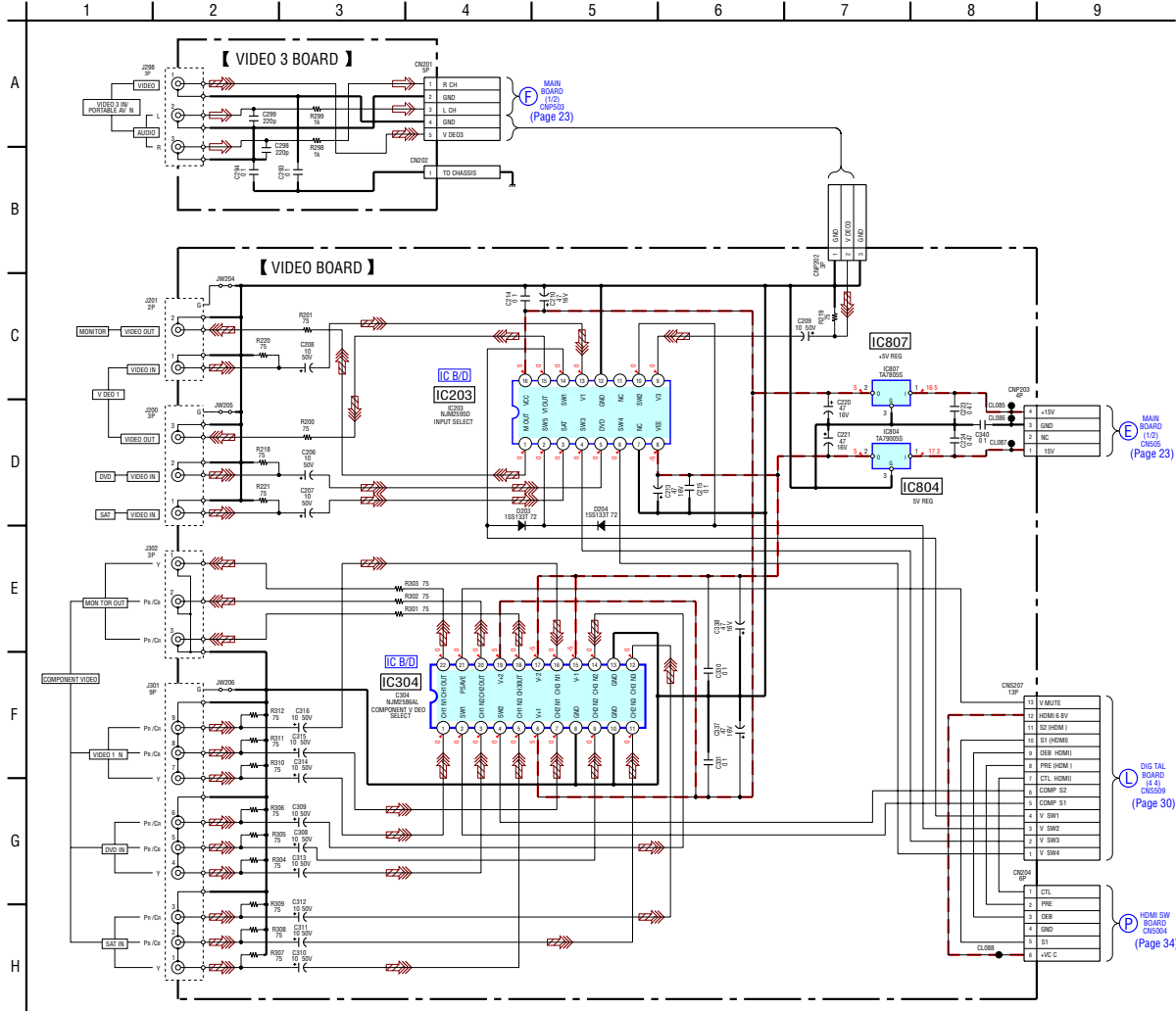



5-18. PRINTED WIRING BOARD — HDMI SW SECTION — • Refer to page 14 for Circuit Boards Location.  : Uses unleaded solder.

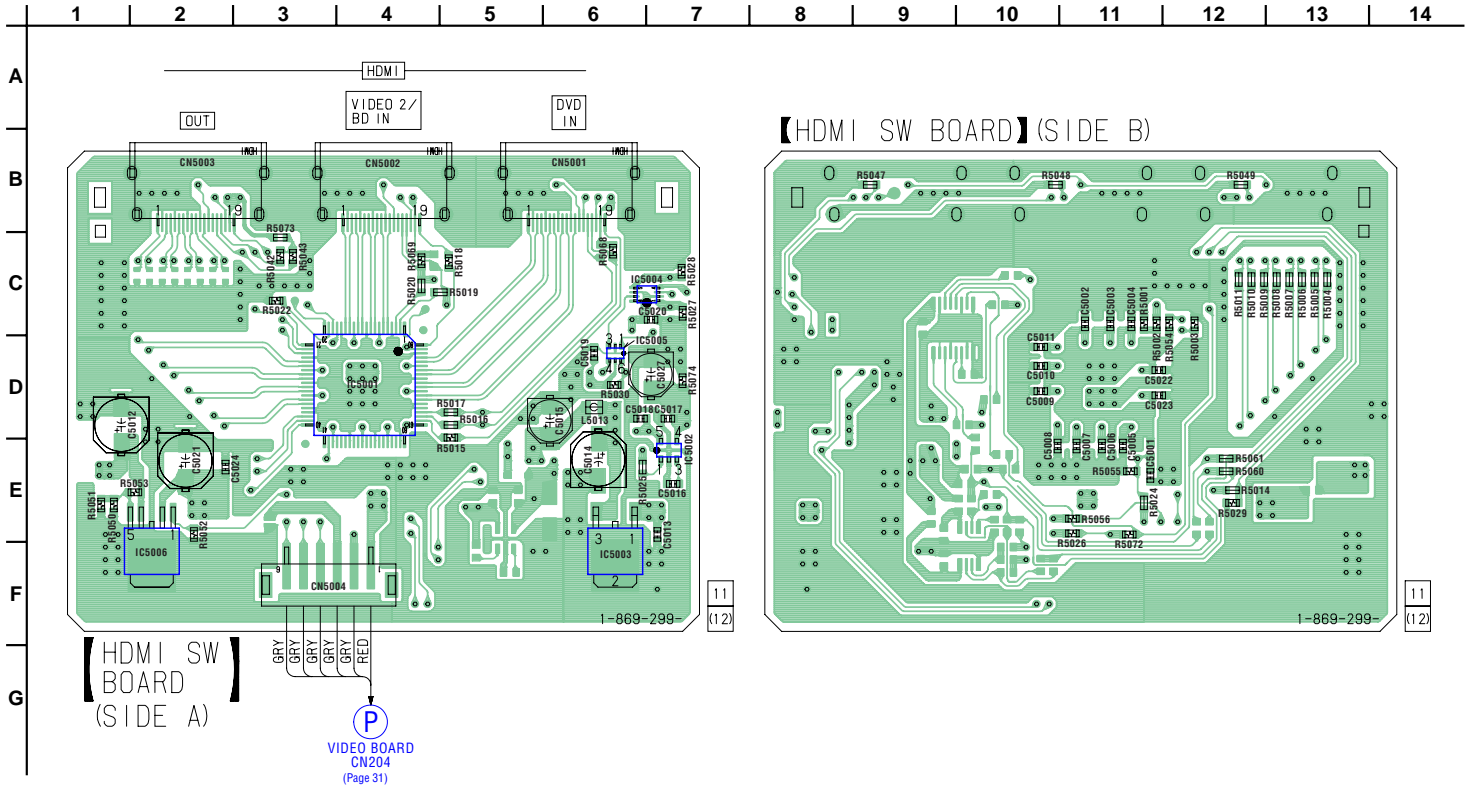

• Semiconductor Location

Ref. No.	Location
IC5001	D-4
IC5002	E-7
IC5003	F-6
IC5004	C-7
IC5005	D-6
IC5006	F-2

5-19. SCHEMATIC DIAGRAM — HDMI SW SECTION — • Refer to page 44 for IC Block Diagrams.

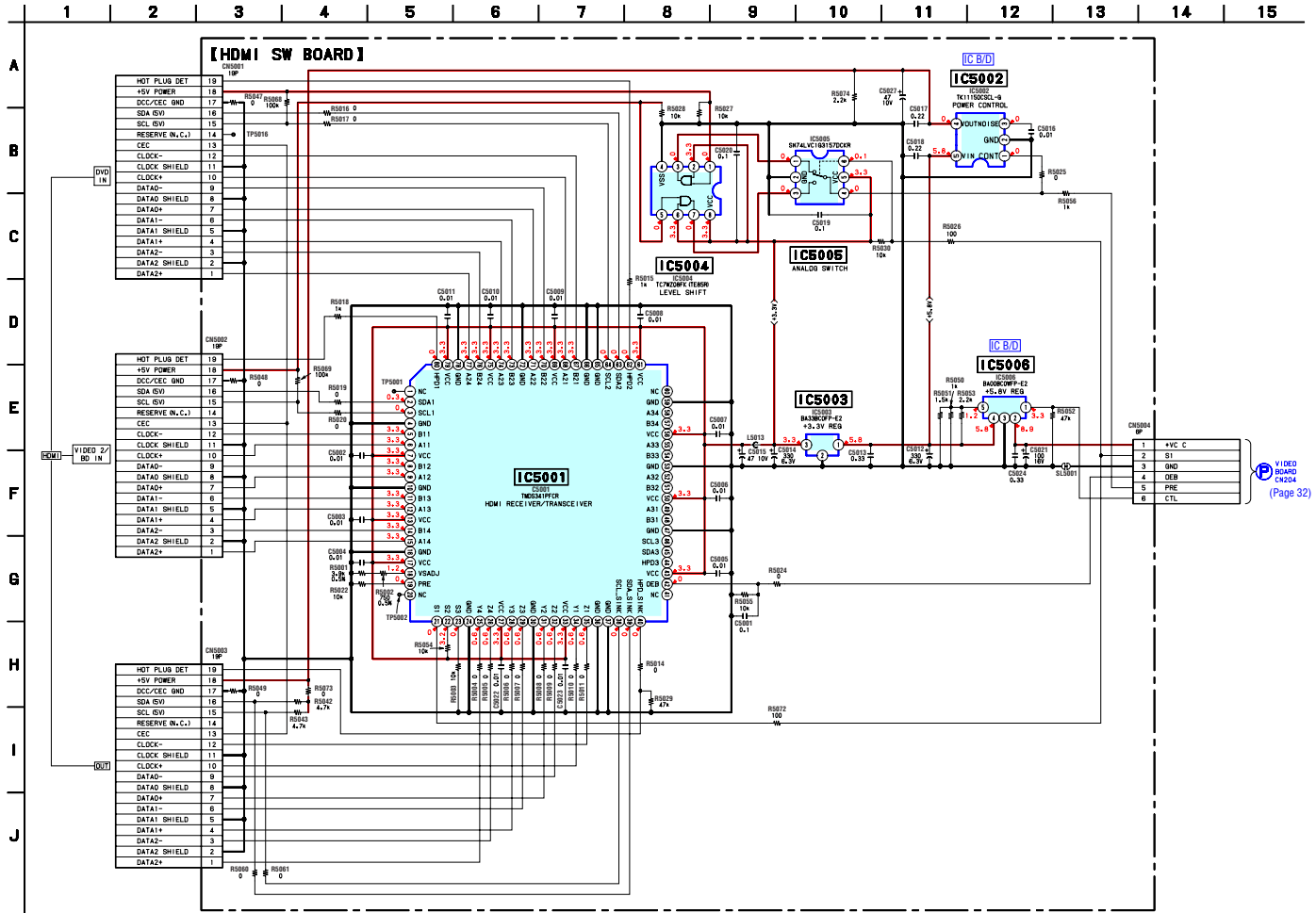

5-20. PRINTED WIRING BOARDS — DCAC, POWER KEY SECTION —

• Refer to page 14 for Circuit Boards Location. **LF** : Uses unleaded solder.

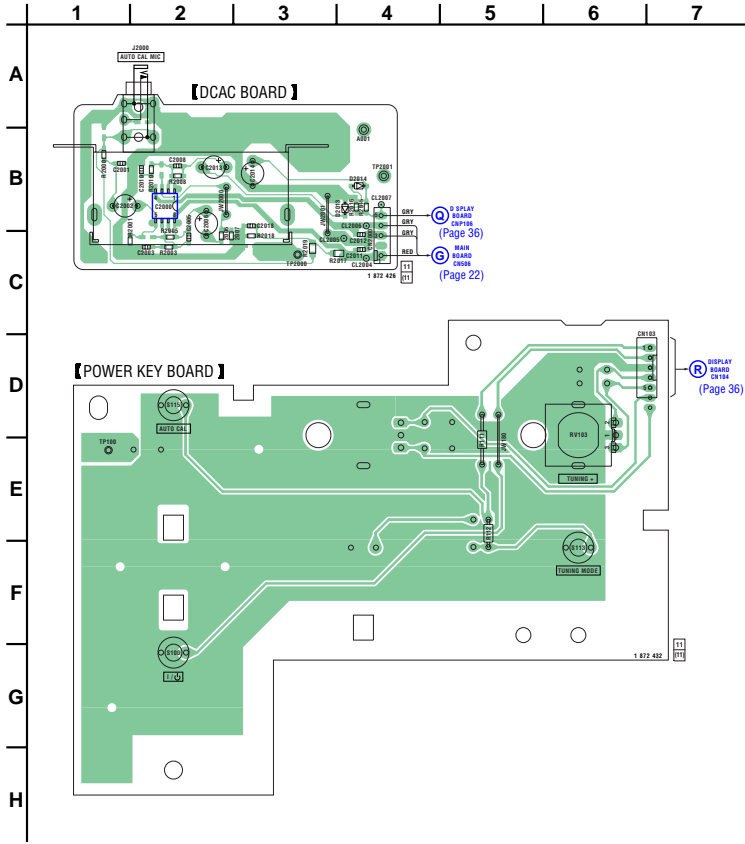

5-21. SCHEMATIC DIAGRAM — DCAC, POWER KEY SECTION —

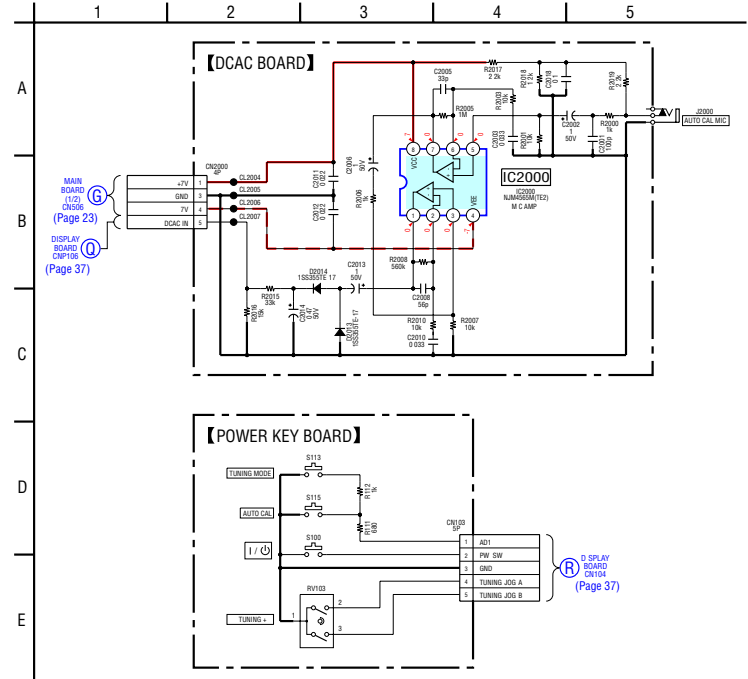

STR-K1600

5-22. PRINTED WIRING BOARD — DISPLAY SECTION — • Refer to page 14 for Circuit Boards Location. **UF** : Uses unleaded solder.

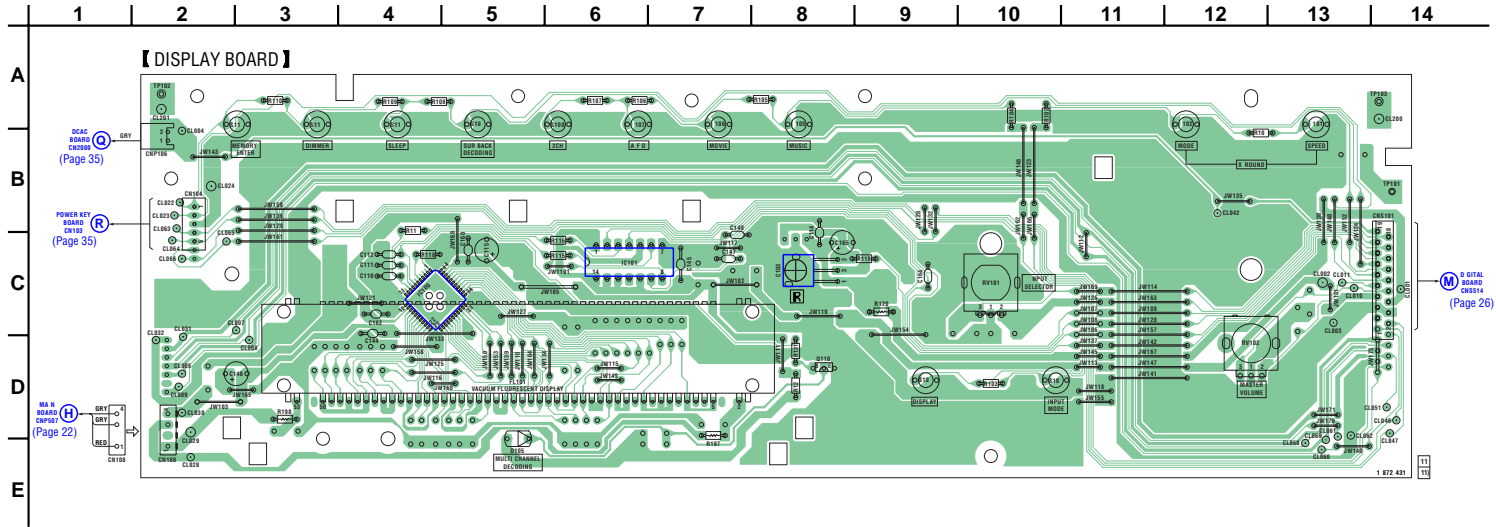

• Semiconductor Location

Ref. No.	Location
D105	E-5
IC100	C-4
IC101	C-6
IC103	C-8
Q110	D-8

5-23. SCHEMATIC DIAGRAM — DISPLAY SECTION —

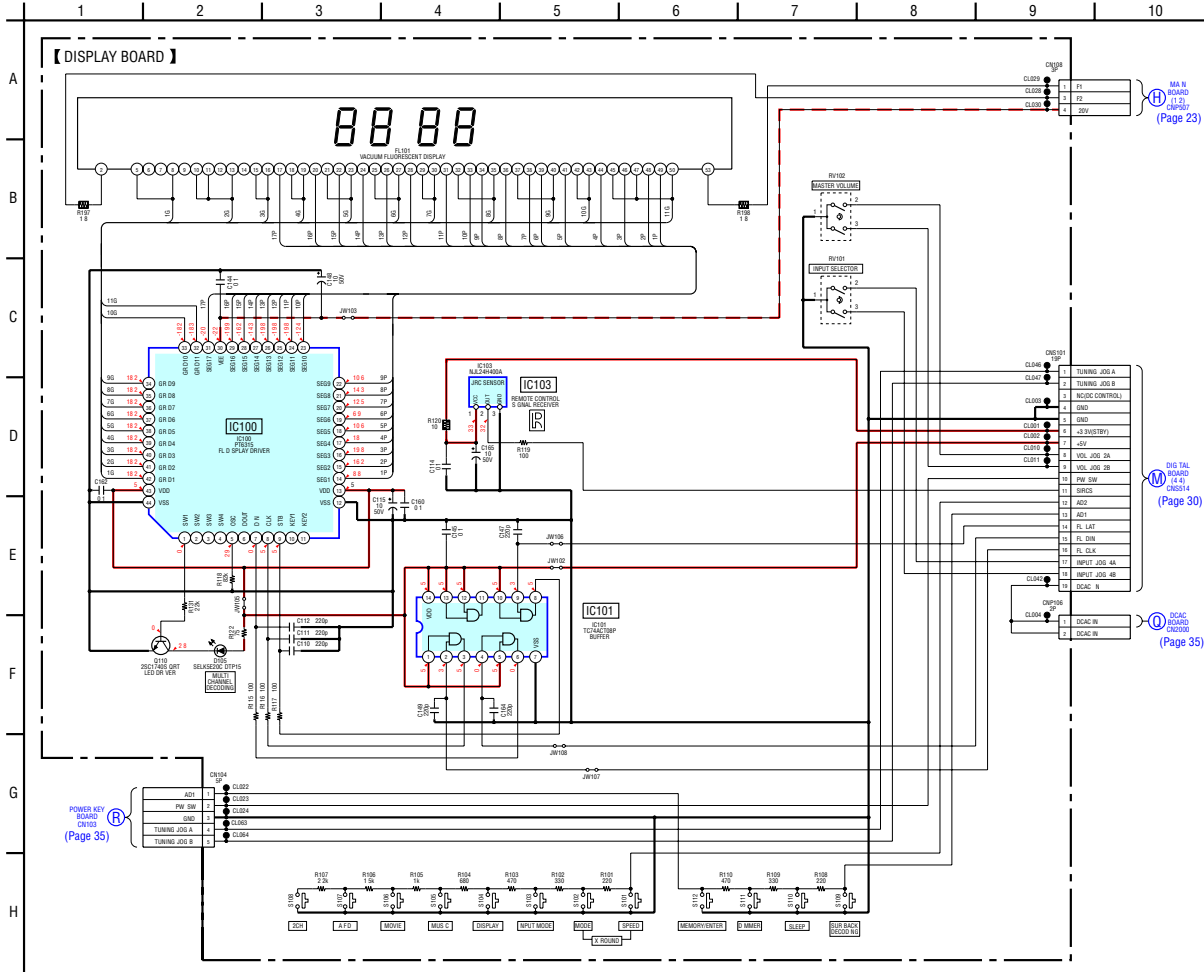

5-24. PRINTED WIRING BOARD — POWER SECTION — • Refer to page 14 for Circuit Boards Location.  : Uses unleaded solder.

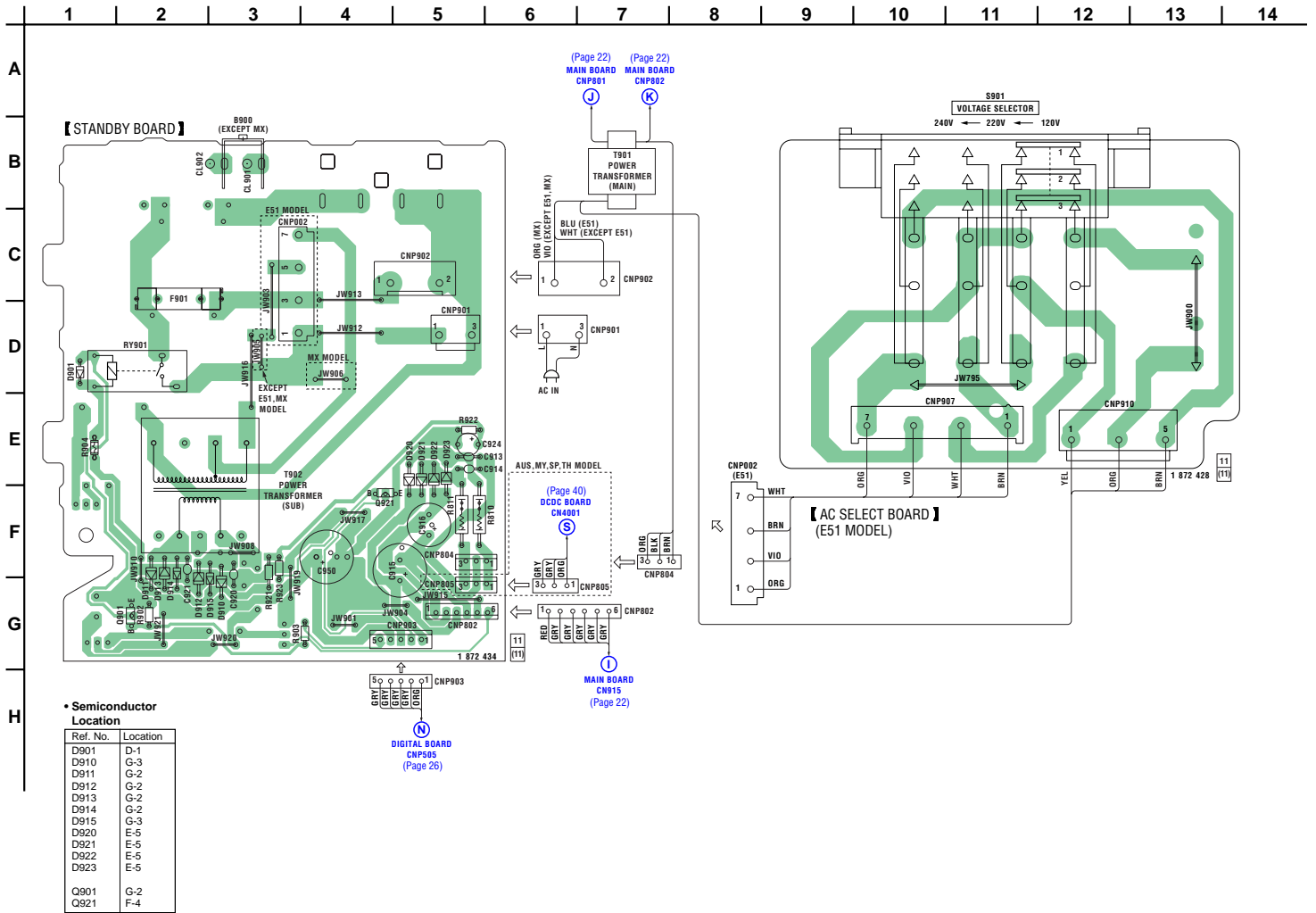

5-25. SCHEMATIC DIAGRAM — POWER SECTION —

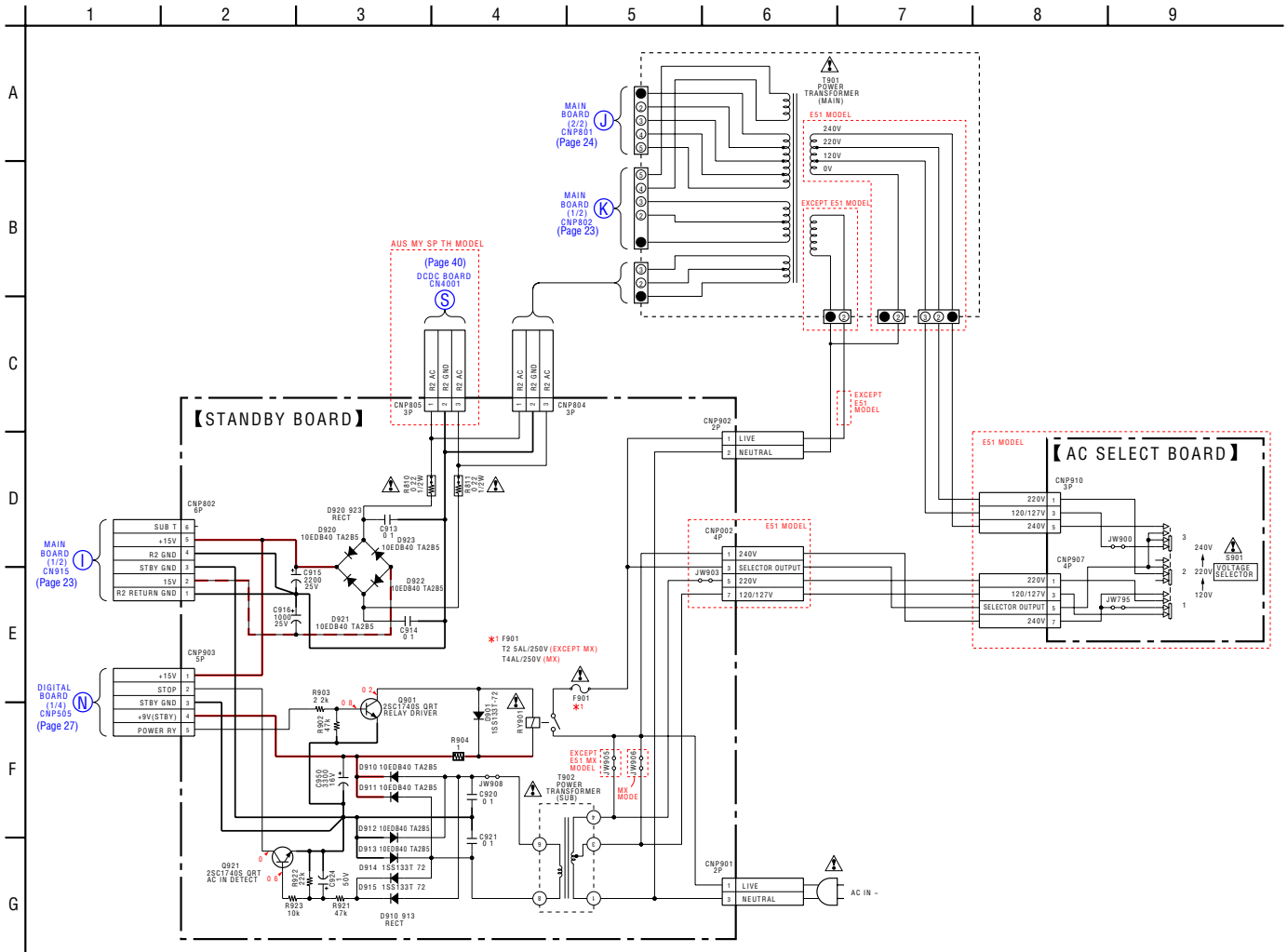

5-26. PRINTED WIRING BOARD — DCDC SECTION (AUS, MY, SP, TH MODEL) —  
• Refer to page 14 for Circuit Boards Location. **AF** : Uses unleaded solder.

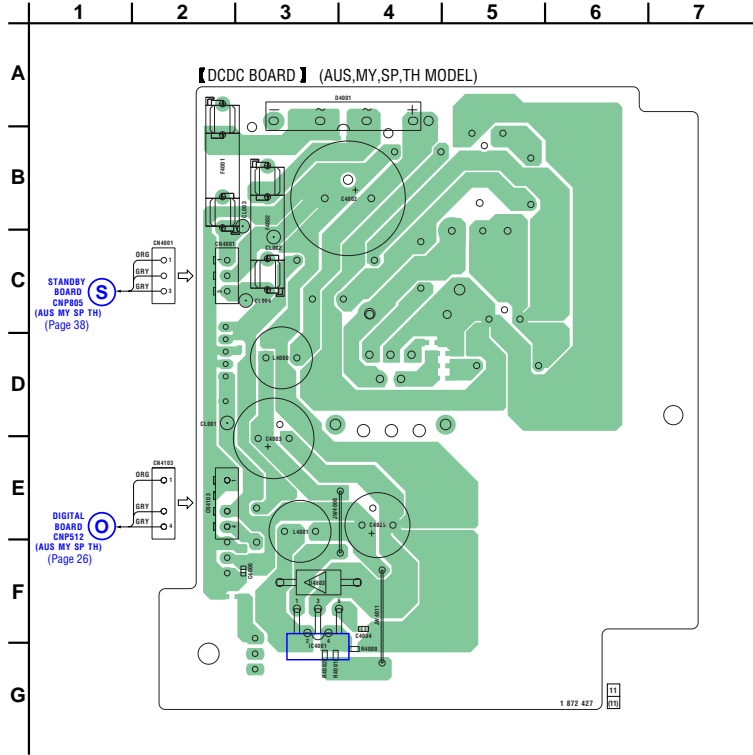

5-27. SCHEMATIC DIAGRAM — DCDC SECTION (AUS, MY, SP, TH MODEL) —

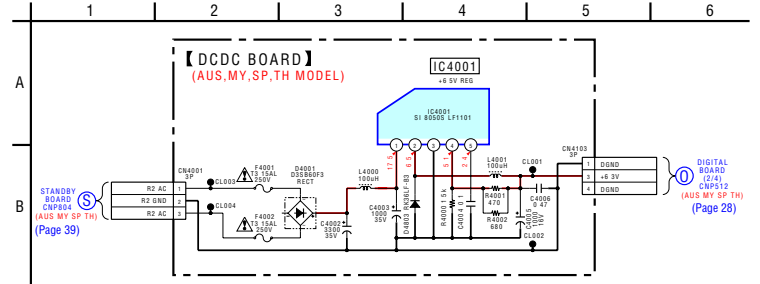



• IC Block Diagrams

IC401 BD3451KS (MAIN BOARD (1/2))

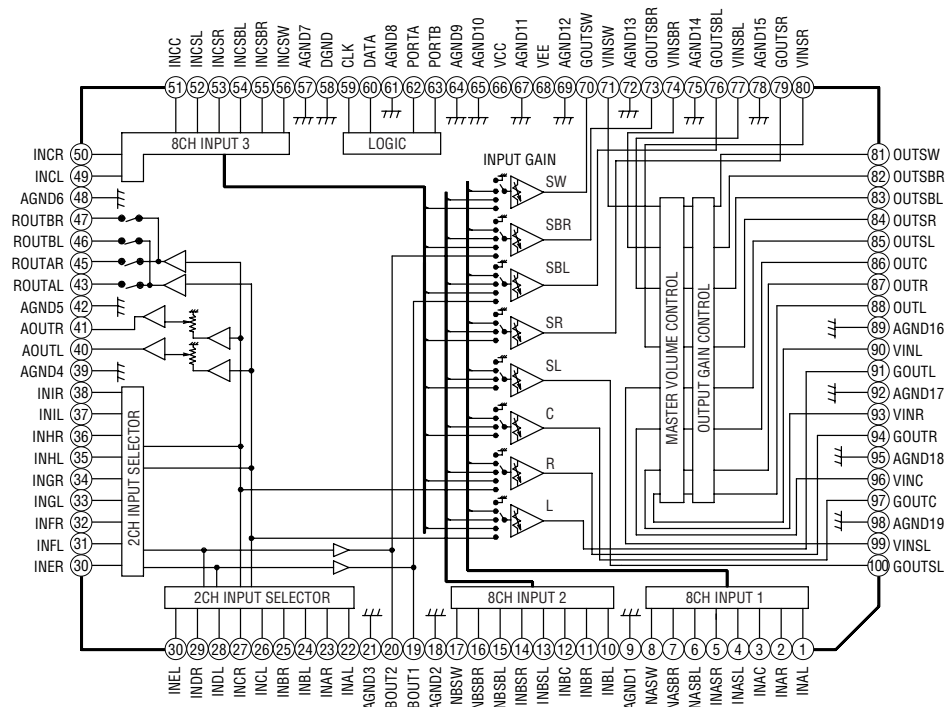

IC501  $\mu$ PC2581V-S (MAIN BOARD (2/2))

IC601  $\mu$ PC2581V-S (MAIN BOARD (2/2))

IC701  $\mu$ PC2581V-S (MAIN BOARD (2/2))

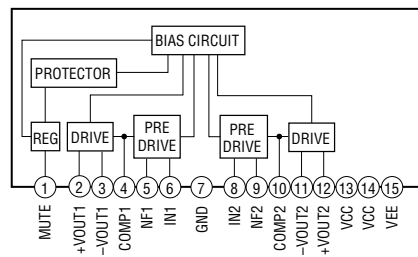

**IC1301 LC89056W-E (DIGITAL BOARD (1/4))**

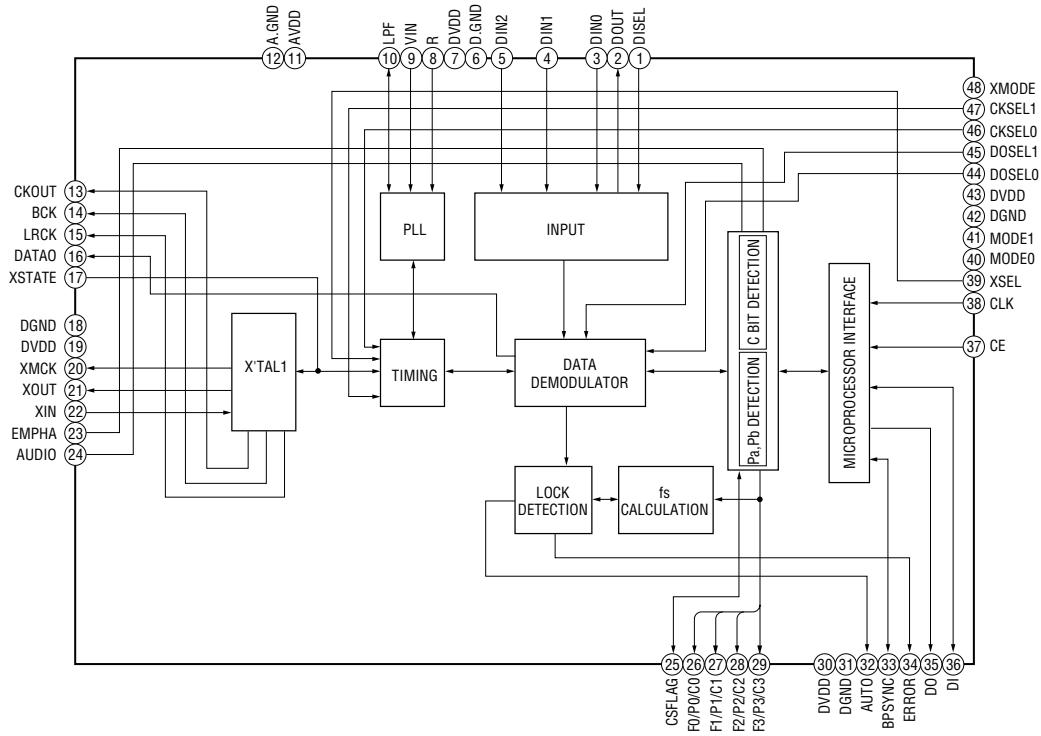

**IC1401 PCM1803DBR (DIGITAL BOARD (2/4))**

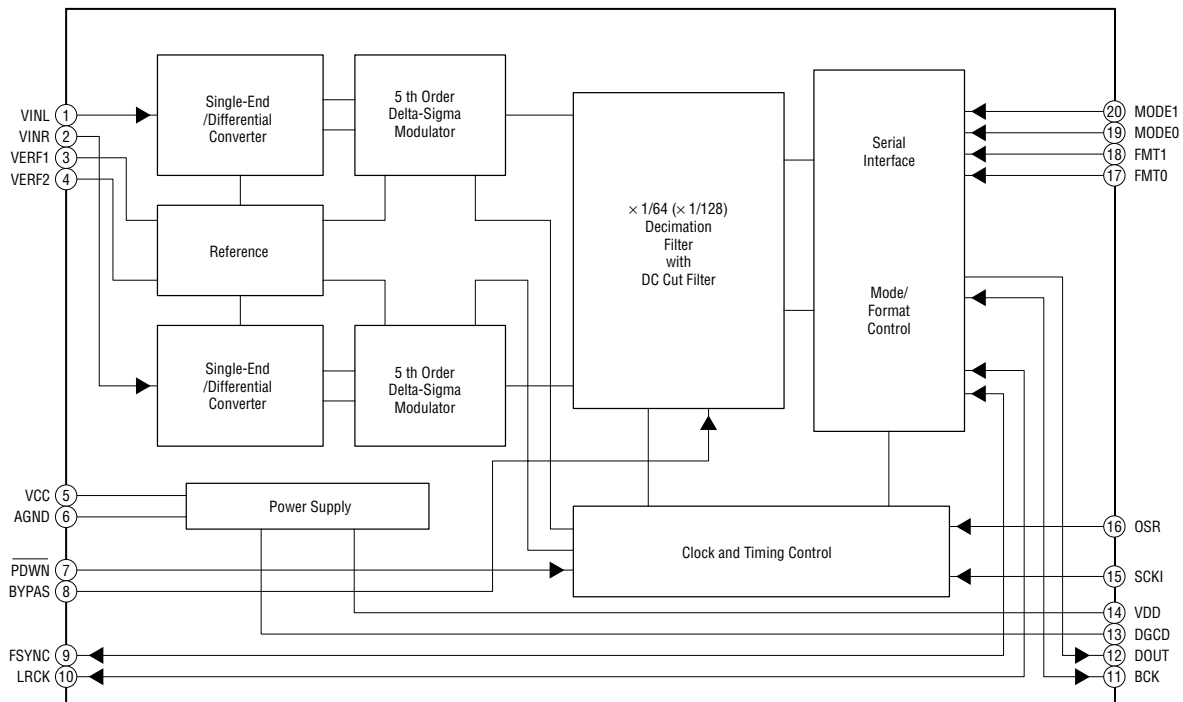

IC1452 PCM1609APT (DIGITAL BOARD (2/4))

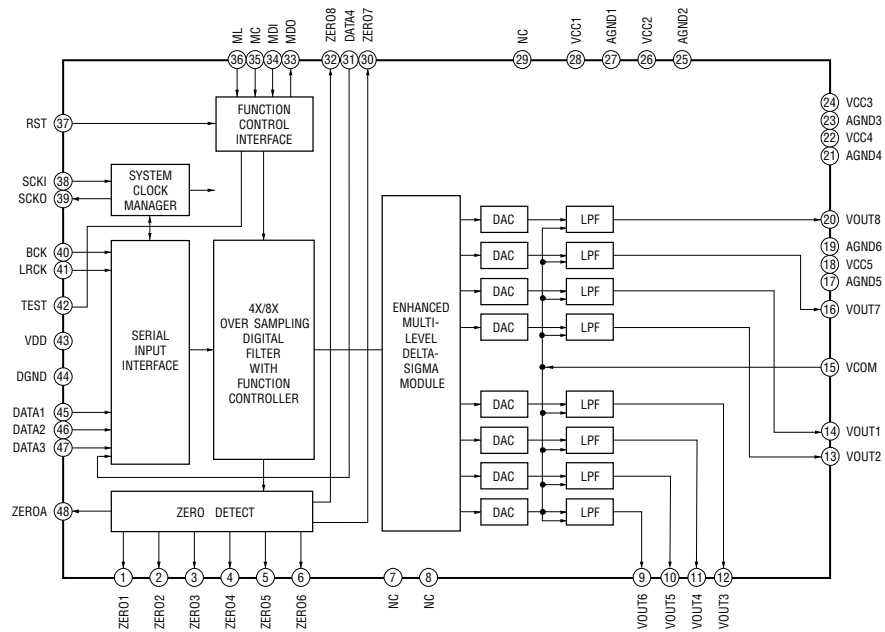

IC203 NJM2595D (VIDEO BOARD)

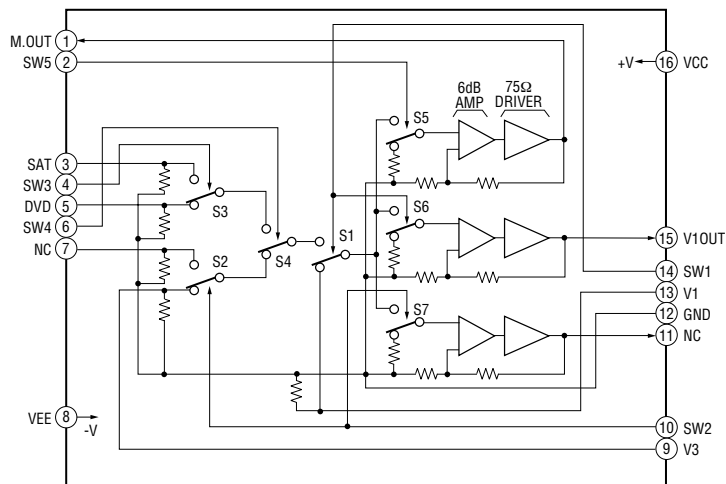

**IC304 NJM2586AL (VIDEO BOARD)**

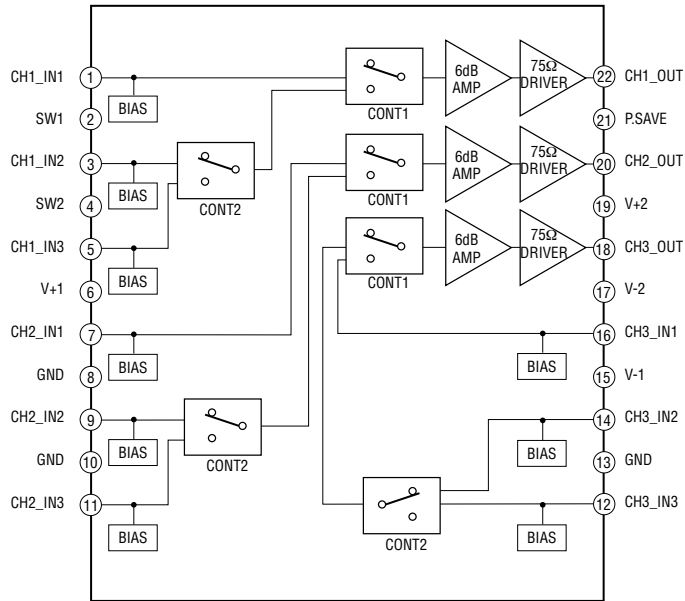

**IC5002 TK11150CSCL-G (HDMI SW BOARD)**

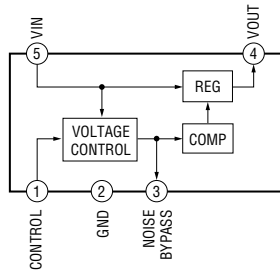

**IC5006 BA00BC0WFP-E2 (HDMI SW BOARD)**

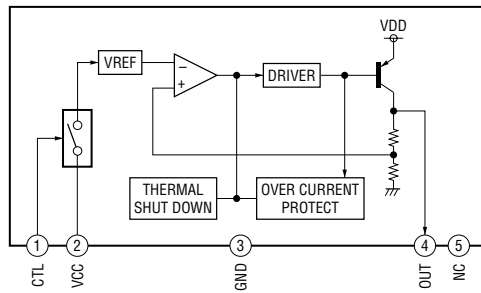

• IC Pin Descriptions  
IC1501 CXD9718BQ (DSP) (DIGITAL BOARD (3/4))

Pin No.	Pin Name	I/O	Pin Description
1	VSS	—	Ground
2	XRST	I	Reset signal input from SYSTEM CONTROL IC
3	EXTIN	I	Not used (Connect to ground)
4	LRCKI3	I	Not used (Connect to ground)
5	VDDI	I	Power supply pin (+1.9 V)
6	BCKI3	I	Not used (Connect to ground)
7	PLOCK	O	Not used (Open)
8	VSS	—	Ground
9	MCLK1	I	Clock signal input (13.9 MHz)
10	VDDI	I	Power supply pin (+1.9 V)
11	VSS	—	Ground
12	MCLK2	O	Clock signal output (13.9 MHz)
13	MS	I	Not used (Fixed at L)
14	SCKOUT	O	Internal system clock signal output for 8CH DAC IC
15	LRCKI1	I	Sampling clock signal input from ADC IC
16	VDDE	I	Power supply pin (+3.4 V)
17	BCKI1	I	Bit clock signal input from ADC IC
18	SDI1	I	Audio IF data input from ADC IC
19	LRCKO	O	Sampling clock signal output for 8CH DAC IC
20	BCKO	O	Bit clock signal output for 8CH DAC IC
21	VSS	—	Ground
22	KFSIO	I/O	Audio clock signal (384fs/256fs) input/output for DIR IC
23 to 26	SDO1 to SDO4	O	Digital audio serial data output for 8CH DAC IC
27	SPDIF	O	Not used (Open)
28	LRCKI2	I	Sampling clock signal input from ADC IC
29	BCKI2	I	Bit clock signal input from ADC IC
30	SDI2	I	Digital audio serial data input from ADC IC
31	VSS	—	Ground
32	HACN	O	Acknowledge signal output for SYSTEM CONTROL IC
33	HDIN	I	Serial data input from SYSTEM CONTROL IC
34	HCLK	I	Clock signal input from SYSTEM CONTROL IC
35	HDOUT	O	Serial data output for SYSTEM CONTROL IC
36	HCS	I	Chip select signal input from SYSTEM CONTROL IC
37	GP12	I	GP12 signal input from SYSTEM CONTROL IC
38, 39	GP13, GP14	O	Not used (Open)
40	VDDI	I	Power supply pin (+1.9 V)
41	VSS	—	Ground
42	GP15	O	Not used (Open)
43	OE0	O	Not used (Open)
44	CS0	O	External memory chip select signal output for D/A converter IC (SDRAM)
45	WE0	O	SDRAM write enable signal output for D/A converter IC (SDRAM)
46	VDDE	I	Power supply pin (+3.4 V)
47	WMD1	I	Not used (Fixed at H)
48	VSS	—	Ground
49	WMD0	I	Not used (Fixed at H)
50	PAGE2	O	Not used (Open)
51	VSS	—	Ground
52, 53	PAGE1, PAGE0	O	Not used (Open)
54	BOOT	I	Not used (Connect to ground)
55	TST1	O	Not used (Open)
56	BST	I	Boot stop signal input from SYSTEM CONTROL IC

Pin No.	Pin Name	I/O	Pin Description
57	MOD1	I	Operation mode signal input (L: 386fs, H: 256fs) (Fixed at H)
58	MOD0	I	Operation mode signal input (L: single chip mode, H: use prohibited) (Fixed at L)
59	EXLOCK	I	Error detection signal input from DIR IC
60	VDDI	I	Power supply pin (+1.9 V)
61	VSS	—	Ground
62, 63	A17, A16	O	Not used (Open)
64 to 66	A15 to A13	O	External memory address signal output for D/A converter IC (SDRAM)
67	GP10	O	Not used (Open)
68	GP9	O	GP9 signal output for SYSTEM CONTROL IC
69	GP8	I	Audio signal input from DIR IC
70	VDDI	I	Power supply pin (+1.9 V)
71	VSS	—	Ground
72 to 75	D15/GP7 to D12/GP4	I/O	External memory data input/output for D/A converter IC (general port)
76	VDDE	I	Power supply pin (+3.4 V)
77 to 80	D11/GP3 to D8/GP0	I/O	External memory data input/output for D/A converter IC (general port)
81	VSS	—	Ground
82	A9	O	External memory address signal output for D/A converter IC (SDRAM)
83 to 85	A12 to A10	O	External memory address signal output for D/A converter IC (SDRAM)
86	TDO	O	Not used (Fixed at H)
87	TMS	I	Not used (Fixed at H)
88	XTRST	I	Not used (Fixed at H)
89	TCK	I	Not used (Fixed at H)
90	TDI	I	Not used (Fixed at H)
91	VSS	—	Ground
92 to 97	A8 to A3	O	External memory address signal output for D/A converter IC (SDRAM)
98, 99	D7, D6	I/O	External memory data input/output for D/A converter IC (SDRAM)
100	VDDI	I	Power supply pin (+1.9 V)
101	VSS	—	Ground
102 to 105	D5 to D2	I/O	External memory data input/output for D/A converter IC (SDRAM)
106	VDDE	I	Power supply pin (+3.4 V)
107, 108	D1, D0	I/O	External memory data input/output for D/A converter IC (SDRAM)
109, 110	A2, A1	O	External memory address signal output for D/A converter IC (SDRAM)
111	VSS	—	Ground
112	A0	O	External memory address signal output for D/A converter IC (SDRAM)
113	PM	I	PLL initialization signal input from SYSTEM CONTROL IC
114, 115	SDI3, SDI4	I	Not used (Open)
116	SYNC	I	Sync/async select signal input (L: sync, H: async) (Fixed at H)
117	TST2	I	Not used (Connect to ground)
118	GP11	I	Not used (Connect to ground)
119	TST3	I	Not used (Connect to ground)
120	VDDI	I	Power supply pin (+1.9 V)

**IC1101 MB90F045PF-G-9050-SPE1 (SYSTEM CONTROL) (DIGITAL BOARD (4/4))**

Pin No.	Pin Name	I/O	Pin Description
1	DATAO	I	Serial data line signal input from DIR IC
2	GP9	I	GP9 signal input from DSP IC
3	BST	O	Boot stop control signal output for DSP IC
4	HCS	O	Chip select signal output for DSP IC
5	HACN	I	Acknowledge signal input from DSP IC
6	XRST	O	Reset signal output for DSP IC
7	PM	O	PLL control signal output for DSP IC
8	GP12	O	GP12 signal output for DSP IC
9	FL_LAT	O	Latch signal output for FL driver IC
10	PCM1609/1803_RST	O	Reset signal output for 8CH DAC IC/ADC IC
11	VSS	—	Ground
12	PCM1609_ML	O	Serial latch signal output for 8CH DAC IC
13	PCM1609_MC	O	Serial clock signal output for 8CH DAC IC
14	PCM1609_MDI	O	Serial data output for 8CH DAC IC
15	PCM1609_MDO	I	Serial data input from 8CH DAC IC
16	FL_CLK	O	Clock signal output for FL driver IC
17	FL_DATA	O	Serial data output for FL driver IC
18	HDOUT	I	Serial data input from DSP IC
19	HDIN	O	Serial data output for DSP IC
20	HCLK	O	Serial data clock signal output for DSP IC
21	TUNING_A	I	TUNING +/- encoder (A) signal input
22	TUNING_B	I	TUNING +/- encoder (B) signal input
23	VCC5	—	Power supply pin (+3.3 V)
24	V_SW1	O	Video SW1 signal output for INPUT SELECT IC
25	V_SW2	O	Video SW2 signal output for INPUT SELECT IC
26	C LINK_DET	I	C Link detect signal input (Australian, Malaysia, Singapore, Thai model)
27	FLASH2/ C LINK_RX(MICLO)	O	Flash programming signal output 2/C Link receive signal output (Australian, Malaysia, Singapore, Thai model)
28	FLASH1/ C LINK_TX(MOCLI)	O	Flash programming signal output 1/C Link transmitter signal output (Australian, Malaysia, Singapore, Thai model)
29	SDA	I/O	Serial data input/output for EEPROM IC
30	SCL	O	Clock signal output for EEPROM IC
31	ENC_A	I	INPUT SELECTOR encoder (A) signal input
32	ENC_B	I	INPUT SELECTOR encoder (B) signal input
33, 34	NC	O	Not used (Open)
35	AVCC	—	Power supply pin (+3.3 V)
36	AVRH	—	Power supply pin (+3.3 V)
37	AVSS	—	Ground
38	ADCC	I	AUTO CAL MIC analog signal input
39, 40	A/D1, A/D2	I	Key signal input (A/D port)
41	VERSION	I	Destination detection signal input
42	VSS	—	Ground
43	RDS_SIG	I	RDS signal level input (Not used in this set)
44	MODEL	I	Model detection signal input
45	VACS_CTRL	I	VACS control signal input
46	TUNER_CLK	O	Serial clock signal output for tuner pack
47	TUNER_DATA	O	Serial data output for tuner pack
48	STOP	I	AC off detection signal input
49	MOD0	—	Selection of micon operation mode
50	MOD1	—	Not used (Connect to AVCC)
51	MOD2	—	Selection of micon operation mode
52	RDS_CLK	I	RDS data clock signal input (Not used in this set)

Pin No.	Pin Name	I/O	Pin Description
53	RDS_DATA	I	RDS data input (Not used in this set)
54	SIRCS	I	SIRCS signal input
55	HP_DETECT	I	Headphones detection signal input
56	POWER_KEY	I	Power key detection signal input
57	ADCC_INT	I	ADCC data input from DSP IC
58	POWER_RY	O	Power relay driver control signal output
59	VOL_IC_CL	O	Clock signal output for DIR IC
60	VOL_IC_DA	O	Serial data and latch output for DIR IC
61	PROTECTOR	I	Protector detection signal input
62	HP_RY	O	Headphone relay driver control signal output
63	FUSE_DETECT	I	Fuse open detection signal input
64	VOL_ENCODER(B)	I	MASTER VOLUME encoder (B) signal input
65	VOL_ENCODER(A)	I	MASTER VOLUME encoder (A) signal input
66	FRONT_A_RY	O	Front speaker relay driver control signal output
67	FRONT_B_RY	O	Front B speaker relay driver control signal output (Not used in this set)
68	DC-CONTROL	O	DCAC DC-BIAS switch control signal output (Not used in this set)
69	C/REAR/SB_RY	O	Center/surround/surround back speaker relay driver control signal output
70	SW_RY	O	Sub woofer relay driver control signal output
71	NC	O	Not used (Open)
72	BRIDGEABLE_RY	O	Bridgeable relay driver control signal output
73	DO/SD/ST	I	Tuner serial data input
74	SLATCH	O	Tuner latch signal output
75	V_SW3	O	Video SW3 signal output for INPUT SELECT IC
76	V_SW4	O	Video SW4 signal output for INPUT SELECT IC
77	RSTX	I	Reset signal input
78	COMP MUTE	O	COMPONENT VIDEO mute signal output
79	X1A	—	Not used (Open)
80	X0A	—	Not used (Connect to VSS)
81	VSS	—	Ground
82	X0	—	Clock signal input (24 MHz)
83	X1	—	Clock signal output (24 MHz)
84	VCC3	—	Power supply pin (+3.3 V)
85	HDMI_S2	O	HDMI S2 signal output (Not used in this set)
86	HDMI_S1	O	HDMI S1 signal output
87	HDMI_OEB	O	HDMI OEB signal output
88	HDMI_PRE	O	HDMI PRE signal output
89	HDMI_CTRL	O	HDMI control signal output
90	COMP_S2	O	COMPONENT VIDEO assign SW2 signal output
91	COMP_S1	O	COMPONENT VIDEO assign SW1 signal output
92	BST_SEL	O	96/24 signal output for DSP IC
93	XMODE	O	Xmode signal output for DIR IC
94	CKSEL1	O	Clock select signal output for DIR IC
95	CLK	O	Data clock signal output for DIR IC
96	CE	O	Latch signal output for DIR IC
97	DI	O	Data output for DIR IC
98	DO	I	Data input from DIR IC
99	ERROR	I	Error detection signal input from DIR IC
100	XSTATE	I	Xstate signal input from DIR IC



## SECTION 6 EXPLODED VIEWS

**NOTE:**

- The mechanical parts with no reference number in the exploded views are not supplied.
- Items marked “\*” are not stocked since they are seldom required for routine service. Some delay should be anticipated when ordering these items.
- Abbreviation  
 MX : Mexican model  
 E51 : Chilean and Peruvian models  
 AUS : Australian model  
 MY : Malaysia model  
 SP : Singapore model  
 TH : Thai model  
 AR : Argentina model

- -XX and -X mean standardized parts, so they may have some difference from the original one.
- Color Indication of Appearance Parts  
 Example :  
 KNOB, BALANCE (WHITE) ... (RED)  
 ↑                    ↑  
 Parts Color    Cabinet's Color
- Accessories are given in the last of this parts list.

The components identified by mark  $\triangle$  or dotted line with mark  $\triangle$  are critical for safety. Replace only with part number specified.

### 6-1. CASE SECTION

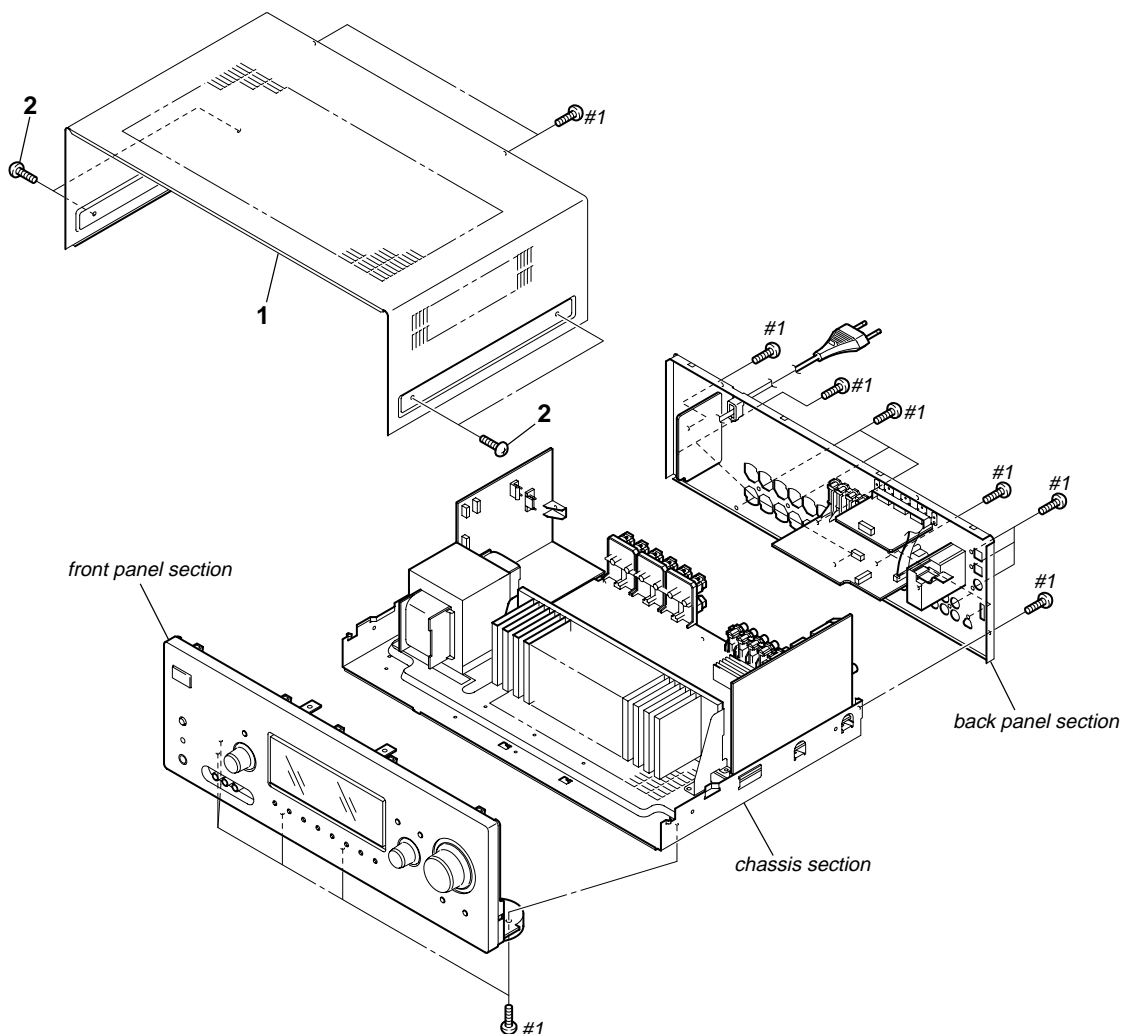

Ref. No.	Part No.	Description	Remark	Ref. No.	Part No.	Description	Remark
1	2-661-145-11	CASE (BLACK)...(BLACK) (MX)		2	3-363-099-11	SCREW (CASE 3 TP2) (SILVER)...(SILVER)	
1	2-661-145-31	CASE (SILVER)...(SILVER) (EXCEPT MX)					(EXCEPT MX)
2	3-363-099-02	SCREW (CASE 3 TP2) (BLACK)...(BLACK) (MX)		#1	7-685-646-79	SCREW +BVTP 3X8 TYPE2 IT-3	

**6-2. FRONT PANEL SECTION**

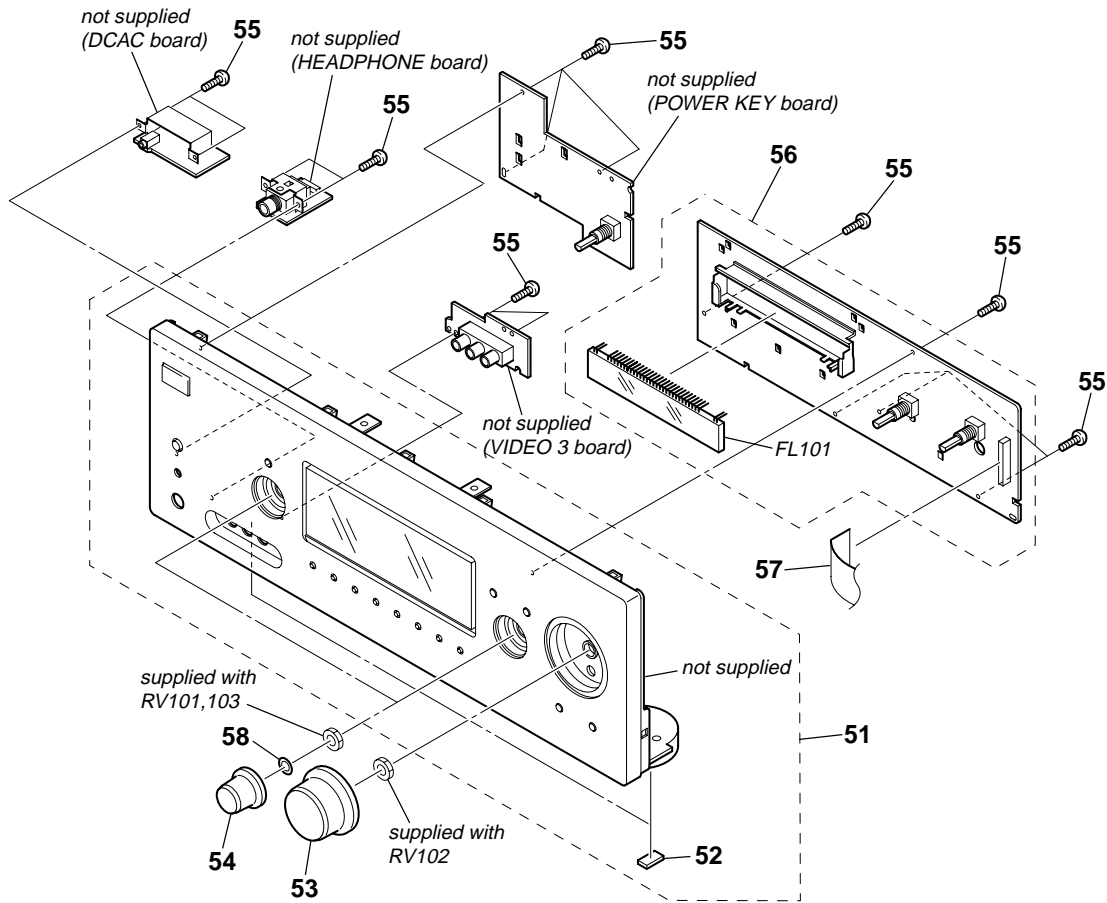

Ref. No.	Part No.	Description	Remark	Ref. No.	Part No.	Description	Remark
51	X-2176-079-1	FRONT PANEL ASSY (SILVER)...(SILVER) (EXCEPT MX)		55	3-087-053-01	+BVTP 2.6 (3CR)	
51	X-2176-080-1	FRONT PANEL ASSY (BLACK)...(BLACK) (MX)		56	A-1223-145-A	DISPLAY BOARD, COMPLETE (EXCEPT E51,MX)	
52	4-977-358-01	CUSHION		56	A-1223-147-A	DISPLAY BOARD, COMPLETE (E51)	
53	2-661-142-01	KNOB (VOLUME) (BLACK)...(BLACK) (MX)		56	A-1251-515-A	DISPLAY BOARD, COMPLETE (MX)	
53	2-661-142-11	KNOB (VOLUME) (SILVER)...(SILVER) (EXCEPT MX)		57	1-829-004-51	WIRE (FLAT TYPE) (19 CORE)	
54	2-661-141-01	KNOB (MENU) (BLACK)...(BLACK) (MX)		58	3-354-981-11	SPRING (SUS), RING	
54	2-661-141-11	KNOB (MENU) (SILVER)...(SILVER) (EXCEPT MX)		FL101	1-519-927-11	VACUUM FLUORESCENT DISPLAY	

6-3. BACK PANEL SECTION

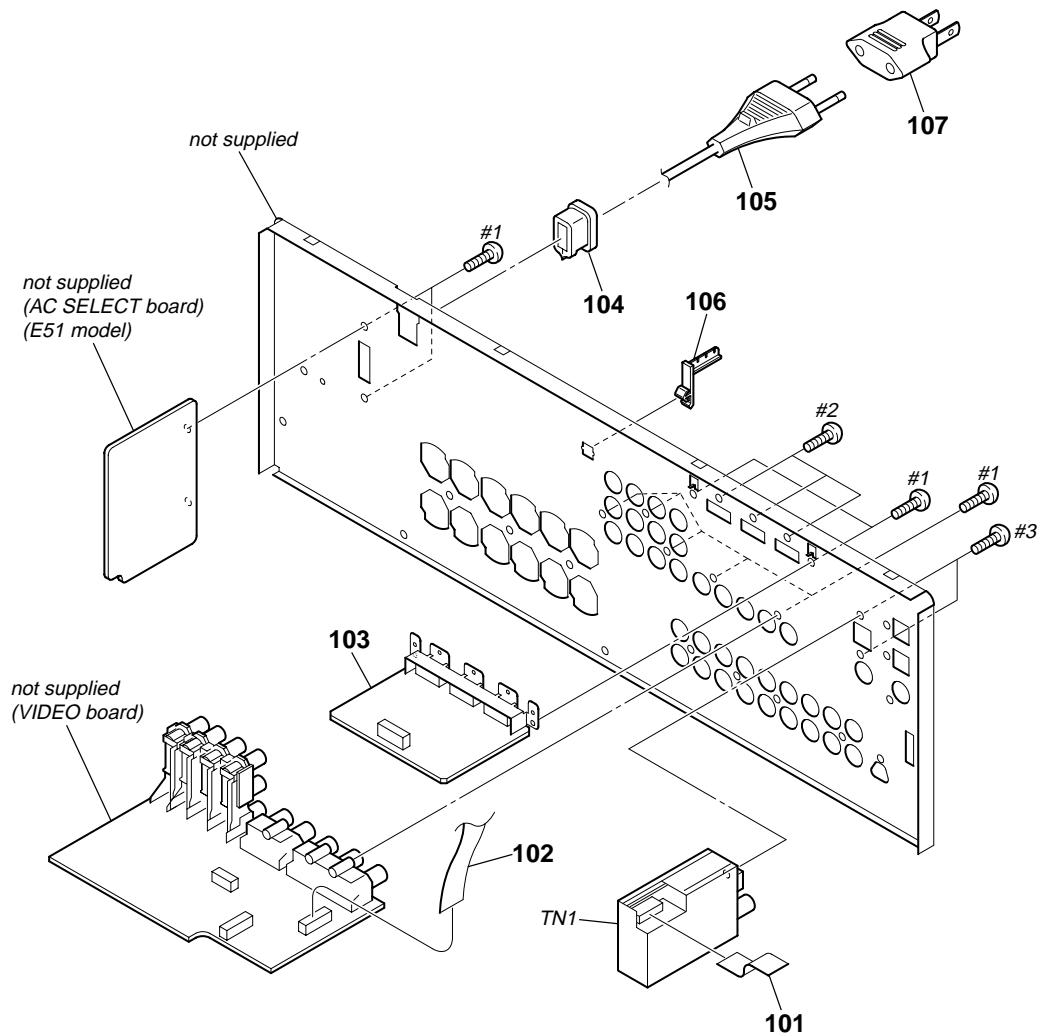

Ref. No.	Part No.	Description	Remark	Ref. No.	Part No.	Description	Remark
	101	1-829-953-11 WIRE (FLAT TYPE) (9 CORE)			106	4-956-370-12 BAND, PLUG FIXED (AUS)	
	102	1-828-973-11 WIRE (FLAT TYPE) (13 CORE)		△ 107	1-569-008-22 ADAPTOR, CONVERSION 2P (E51)		
	103	A-1158-394-A HDMI SW BOARD, COMPLETE (EXCEPT MX)		TN1	1-693-728-11 TUNER (FM/AM) (ANTENNA) (MX)		
	103	A-1251-524-A HDMI SW BOARD, COMPLETE (MX)		TN1	1-693-733-11 TUNER (FM/AM) (ANTENNA) (E51,AR)		
	104	3-703-244-21 BUSHING (2104), CORD		TN1	1-693-735-11 TUNER (FM/AM) (ANTENNA) (AUS,MY,SP,TH)		
△ 105	1-696-848-81	CORD, POWER (AUS)		#1	7-685-646-79	SCREW +BVTP 3X8 TYPE2 IT-3	
△ 105	1-777-071-83	CORD, POWER (E51,MY,SP,TH)		#2	7-685-871-01	SCREW +BVTT 3X6 (S)	
△ 105	1-783-941-12	CORD, POWER (AR)		#3	7-685-862-09	SCREW +BVTT 2.6X6 (S)	
△ 105	1-829-627-11	POWER-SUPPLY CORD (MX)					

**6-4. CHASSIS SECTION**

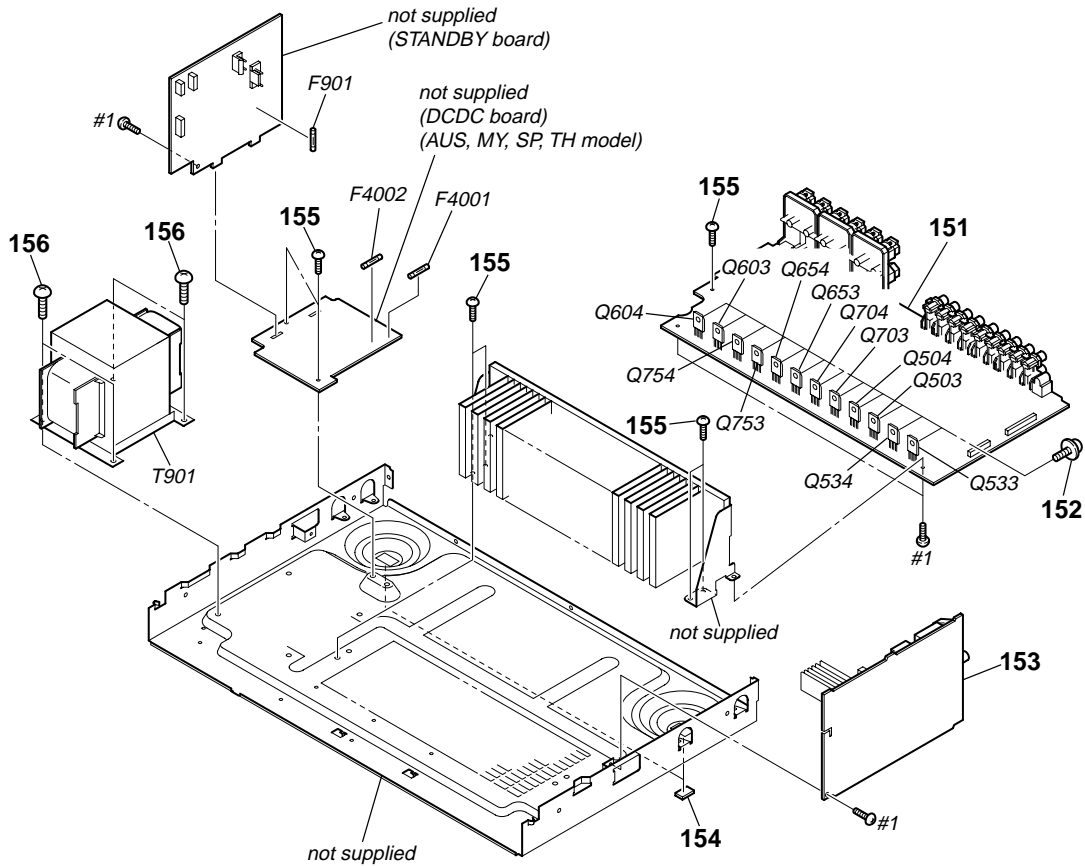

Ref. No.	Part No.	Description	Remark	Ref. No.	Part No.	Description	Remark
151	A-1223-131-A	MAIN BOARD, COMPLETE (MY,SP,TH)		Q503	6-702-390-01	TRANSISTOR MN2488-OPY-MK	
151	A-1223-132-A	MAIN BOARD, COMPLETE (AUS)		Q504	6-702-391-01	TRANSISTOR MP1620-OPY-MK	
151	A-1223-133-A	MAIN BOARD, COMPLETE (E51,AR)		Q533	6-702-390-01	TRANSISTOR MN2488-OPY-MK	
151	A-1251-510-A	MAIN BOARD, COMPLETE (MX)		Q534	6-702-391-01	TRANSISTOR MP1620-OPY-MK	
152	3-905-609-01	SCREW (TRANSISTOR)		Q603	6-702-390-01	TRANSISTOR MN2488-OPY-MK	
153	A-1223-018-A	DIGITAL BOARD, COMPLETE (MY,SP,TH)		Q604	6-702-391-01	TRANSISTOR MP1620-OPY-MK	
153	A-1223-019-A	DIGITAL BOARD, COMPLETE (AUS)		Q653	6-702-390-01	TRANSISTOR MN2488-OPY-MK	
153	A-1223-020-A	DIGITAL BOARD, COMPLETE (E51)		Q654	6-702-391-01	TRANSISTOR MP1620-OPY-MK	
153	A-1223-021-A	DIGITAL BOARD, COMPLETE (AR)		Q703	6-702-390-01	TRANSISTOR MN2488-OPY-MK	
153	A-1251-522-A	DIGITAL BOARD, COMPLETE (MX)		Q704	6-702-391-01	TRANSISTOR MP1620-OPY-MK	
154	4-977-358-01	CUSHION		Q753	6-702-390-01	TRANSISTOR MN2488-OPY-MK	
155	3-077-331-21	+BV 3 (3-CR)		Q754	6-702-391-01	TRANSISTOR MP1620-OPY-MK	
156	4-249-675-01	+BV SUMITITE S 4X6 ROUND		△T901	1-443-523-11	TRANSFORMER, POWER (MAIN) (MX)	
△F901	1-532-464-33	FUSE (T2.5AL/250V) (EXCEPT MX)		△T901	1-443-525-11	TRANSFORMER, POWER (MAIN)	(EXCEPT E51,MX)
△F901	1-532-504-33	FUSE (T4AL/250V) (MX)		△T901	1-443-526-11	TRANSFORMER, POWER (MAIN) (E51)	
△F4001	1-532-465-33	FUSE (T3.15AL/250V) (AUS,MY,SP,TH)		#1	7-685-646-79	SCREW +BVTP 3X8 TYPE2 IT-3	
△F4002	1-532-465-33	FUSE (T3.15AL/250V) (AUS,MY,SP,TH)					

## SECTION 7 ELECTRICAL PARTS LIST

AC SELECT   DCAC   DCDC

**NOTE:**

- Due to standardization, replacements in the parts list may be different from the parts specified in the diagrams or the components used on the set.
- RESISTORS  
All resistors are in ohms.  
METAL: Metal-film resistor.  
METAL OXIDE: Metal oxide-film resistor.  
F: nonflammable
- Items marked "\*" are not stocked since they are seldom required for routine service. Some delay should be anticipated when ordering these items.

- SEMICONDUCTORS  
In each case, u :  $\mu$ , for example:  
uA.. :  $\mu$ A..   uPA.. :  $\mu$ PA..  
uPB.. :  $\mu$ PB..   uPC.. :  $\mu$ PC..   uPD.. :  $\mu$ PD..
- CAPACITORS  
uF :  $\mu$ F
- COILS  
uH :  $\mu$ H
- Abbreviation  
E51 : Chilean and Peruvian models  
AUS : Australian model  
MY : Malaysia model  
SP : Singapore model  
TH : Thai model  
AR : Argentina model  
MX : Mexican model

The components identified by mark  $\Delta$  or dotted line with mark  $\Delta$  are critical for safety. Replace only with part number specified.

When indicating parts by reference number, please include the board.

Ref. No.	Part No.	Description	Remark	Ref. No.	Part No.	Description	Remark
		AC SELECT BOARD (E51) *****					
		< CONNECTOR >					
* CNP910	1-564-687-11	PIN, CONNECTOR (3.96mm PITCH) 3P		R2007	1-216-833-11	METAL CHIP 10K 5%	1/10W
		< SWITCH >		R2008	1-216-854-11	METAL CHIP 560K 5%	1/10W
$\Delta$ S901	1-571-437-21	SWITCH, POWER VOLTAGE CHANGE (VOLTAGE SELECTOR) *****		R2010	1-216-833-11	METAL CHIP 10K 5%	1/10W
		DCAC BOARD *****		R2015	1-216-839-11	METAL CHIP 33K 5%	1/10W
		< CAPACITOR >		R2016	1-216-835-11	METAL CHIP 15K 5%	1/10W
C2001	1-162-927-11	CERAMIC CHIP 100PF 5%	50V	R2017	1-216-825-11	METAL CHIP 2.2K 5%	1/10W
C2002	1-126-160-11	ELECT 1uF 20%	50V	R2018	1-216-822-11	METAL CHIP 1.2K 5%	1/10W
C2003	1-164-373-11	CERAMIC CHIP 0.033uF	25V	R2019	1-216-825-11	METAL CHIP 2.2K 5%	1/10W
C2005	1-162-921-11	CERAMIC CHIP 33PF 5%	50V	*****			
C2006	1-126-160-11	ELECT 1uF 20%	50V			DCDC BOARD (AUS,MY,SP,TH) *****	
C2008	1-162-924-11	CERAMIC CHIP 56PF 5%	50V		1-533-313-11	HOLDER, FUSE	
C2010	1-164-373-11	CERAMIC CHIP 0.033uF	25V			< CAPACITOR >	
C2011	1-162-995-11	CERAMIC CHIP 0.022uF	50V	C4002	1-128-549-11	ELECT 3300uF 20%	35V
C2012	1-162-995-11	CERAMIC CHIP 0.022uF	50V	C4003	1-115-814-11	ELECT 0.001F 20%	35V
C2013	1-126-160-11	ELECT 1uF 20%	50V	C4004	1-100-566-11	CERAMIC CHIP 0.1uF 10%	25V
C2014	1-124-465-00	ELECT 0.47uF 20%	50V	C4005	1-128-950-21	ELECT 1000uF 20%	16V
C2018	1-164-156-11	CERAMIC CHIP 0.1uF	25V	C4006	1-125-891-11	CERAMIC CHIP 0.47uF 10%	10V
		< DIODE >				< DIODE >	
D2013	8-719-988-61	DIODE 1SS355TE-17		D4001	8-719-077-77	DIODE D3SB60F3	
D2014	8-719-988-61	DIODE 1SS355TE-17		D4803	8-719-080-53	DIODE RK36LF-B3	
		< IC >				< IC >	
IC2000	8-759-710-97	IC NJM4565M-D		IC4001	8-759-474-09	IC SI-8050S-LF1101	
		< JACK >				< COIL >	
J2000	1-820-056-11	JACK (SMALL TYPE) (AUTO CAL MIC)		L4000	1-456-545-11	INDUCTOR 100uH	
		< RESISTOR >		L4001	1-456-545-11	INDUCTOR 100uH	
R2000	1-216-821-11	METAL CHIP 1K 5%	1/10W			< RESISTOR >	
R2001	1-216-833-11	METAL CHIP 10K 5%	1/10W	R4000	1-216-823-11	METAL CHIP 1.5K 5%	1/10W
R2003	1-216-833-11	METAL CHIP 10K 5%	1/10W	R4001	1-216-817-11	METAL CHIP 470 5%	1/10W
R2005	1-216-857-11	METAL CHIP 1M 5%	1/10W	R4002	1-216-819-11	METAL CHIP 680 5%	1/10W
R2006	1-216-821-11	METAL CHIP 1K 5%	1/10W	*****			

# STR-K1600

Ver. 1.1

DIGITAL

Ref. No.	Part No.	Description	Remark	Ref. No.	Part No.	Description	Remark
	A-1223-018-A	DIGITAL BOARD, COMPLETE (MY,SP,TH)		C1312	1-100-566-11	CERAMIC CHIP 0.1uF	10% 25V
	A-1223-019-A	DIGITAL BOARD, COMPLETE (AUS)		C1313	1-162-927-11	CERAMIC CHIP 100PF	5% 50V
	A-1223-020-A	DIGITAL BOARD, COMPLETE (E51)		C1314	1-100-566-11	CERAMIC CHIP 0.1uF	10% 25V
	A-1223-021-A	DIGITAL BOARD, COMPLETE (AR)		C1315	1-100-566-11	CERAMIC CHIP 0.1uF	10% 25V
	A-1251-522-A	DIGITAL BOARD, COMPLETE (MX)		C1351	1-100-566-11	CERAMIC CHIP 0.1uF	10% 25V
	*****						
	7-685-646-79	SCREW +BVTP 3X8 TYPE2 IT-3		C1354	1-100-566-11	CERAMIC CHIP 0.1uF	10% 25V
	< CAPACITOR >						
C1001	1-126-925-11	ELECT 470uF	20% 10V	C1355	1-104-662-11	ELECT 22uF	20% 25V
C1002	1-125-891-11	CERAMIC CHIP 0.47uF	10% 10V	C1358	1-100-566-11	CERAMIC CHIP 0.1uF	10% 25V
C1004	1-100-566-11	CERAMIC CHIP 0.1uF	10% 25V	C1359	1-126-916-11	ELECT 1000uF	20% 6.3V
C1005	1-100-566-11	CERAMIC CHIP 0.1uF	10% 25V	C1361	1-100-566-11	CERAMIC CHIP 0.1uF	10% 25V
C1019	1-100-566-11	CERAMIC CHIP 0.1uF	10% 25V	C1362	1-162-974-11	CERAMIC CHIP 0.01uF	50V
C1021	1-137-980-11	CERAMIC CHIP 0.47uF	10% 50V	C1401	1-100-566-11	CERAMIC CHIP 0.1uF	10% 25V
C1022	1-135-372-31	ELECT 470uF	20% 10V	C1402	1-126-947-11	ELECT 47uF	20% 35V
C1031	1-137-980-11	CERAMIC CHIP 0.47uF	10% 50V	C1403	1-126-964-11	ELECT 10uF	20% 50V
C1032	1-135-372-31	ELECT 470uF	20% 10V	C1404	1-100-566-11	CERAMIC CHIP 0.1uF	10% 25V
C1067	1-162-960-11	CERAMIC CHIP 220PF	10% 50V	C1405	1-100-566-11	CERAMIC CHIP 0.1uF	10% 25V
C1068	1-162-960-11	CERAMIC CHIP 220PF	10% 50V	C1406	1-126-964-11	ELECT 10uF	20% 50V
C1100	1-100-566-11	CERAMIC CHIP 0.1uF	10% 25V	C1407	1-126-964-11	ELECT 10uF	20% 50V
C1102	1-100-566-11	CERAMIC CHIP 0.1uF	10% 25V	C1408	1-100-566-11	CERAMIC CHIP 0.1uF	10% 25V
C1103	1-126-947-11	ELECT 47uF	20% 35V	C1409	1-162-970-11	CERAMIC CHIP 0.01uF	10% 25V
C1107	1-100-566-11	CERAMIC CHIP 0.1uF	10% 25V	C1411	1-162-963-11	CERAMIC CHIP 680PF	10% 50V
C1108	1-100-566-11	CERAMIC CHIP 0.1uF	10% 25V	C1413	1-162-961-11	CERAMIC CHIP 330PF	10% 50V
C1118	1-100-566-11	CERAMIC CHIP 0.1uF	10% 25V	C1414	1-162-970-11	CERAMIC CHIP 0.01uF	10% 25V
C1119	1-100-566-11	CERAMIC CHIP 0.1uF	10% 25V	C1415	1-162-970-11	CERAMIC CHIP 0.01uF	10% 25V
C1120	1-100-566-11	CERAMIC CHIP 0.1uF	10% 25V	C1418	1-126-964-11	ELECT 10uF	20% 50V
C1121	1-100-566-11	CERAMIC CHIP 0.1uF	10% 25V	C1420	1-100-566-11	CERAMIC CHIP 0.1uF	10% 25V
C1122	1-100-566-11	CERAMIC CHIP 0.1uF	10% 25V	C1422	1-162-963-11	CERAMIC CHIP 680PF	10% 50V
C1123	1-100-566-11	CERAMIC CHIP 0.1uF	10% 25V	C1423	1-162-961-11	CERAMIC CHIP 330PF	10% 50V
C1124	1-100-566-11	CERAMIC CHIP 0.1uF	10% 25V	C1428	1-126-964-11	ELECT 10uF	20% 50V
C1129	1-162-974-11	CERAMIC CHIP 0.01uF	50V	C1432	1-162-963-11	CERAMIC CHIP 680PF	10% 50V
C1131	1-162-974-11	CERAMIC CHIP 0.01uF	50V	C1433	1-162-961-11	CERAMIC CHIP 330PF	10% 50V
C1132	1-162-974-11	CERAMIC CHIP 0.01uF	50V	C1438	1-126-964-11	ELECT 10uF	20% 50V
C1137	1-162-970-11	CERAMIC CHIP 0.01uF	10% 25V	C1441	1-162-963-11	CERAMIC CHIP 680PF	10% 50V
C1138	1-100-566-11	CERAMIC CHIP 0.1uF	10% 25V	C1442	1-162-961-11	CERAMIC CHIP 330PF	10% 50V
C1139	1-100-566-11	CERAMIC CHIP 0.1uF	10% 25V	C1448	1-126-964-11	ELECT 10uF	20% 50V
C1140	1-100-566-11	CERAMIC CHIP 0.1uF	10% 25V	C1450	1-100-566-11	CERAMIC CHIP 0.1uF	10% 25V
C1142	1-100-566-11	CERAMIC CHIP 0.1uF	10% 25V	C1451	1-162-963-11	CERAMIC CHIP 680PF	10% 50V
C1144	1-162-974-11	CERAMIC CHIP 0.01uF	50V	C1453	1-162-961-11	CERAMIC CHIP 330PF	10% 50V
C1145	1-162-974-11	CERAMIC CHIP 0.01uF	50V	C1454	1-100-566-11	CERAMIC CHIP 0.1uF	10% 25V
C1149	1-162-960-11	CERAMIC CHIP 220PF	10% 50V	C1455	1-126-964-11	ELECT 10uF	20% 50V
C1171	1-162-974-11	CERAMIC CHIP 0.01uF	50V	C1457	1-126-964-11	ELECT 10uF	20% 50V
C1172	1-162-974-11	CERAMIC CHIP 0.01uF	50V	C1458	1-126-964-11	ELECT 10uF	20% 50V
C1253	1-162-960-11	CERAMIC CHIP 220PF	10% 50V	C1462	1-162-963-11	CERAMIC CHIP 680PF	10% 50V
C1254	1-162-960-11	CERAMIC CHIP 220PF	10% 50V	C1463	1-162-961-11	CERAMIC CHIP 330PF	10% 50V
C1255	1-162-960-11	CERAMIC CHIP 220PF	10% 50V	C1468	1-126-964-11	ELECT 10uF	20% 50V
C1299	1-100-566-11	CERAMIC CHIP 0.1uF	10% 25V	C1471	1-100-566-11	CERAMIC CHIP 0.1uF	10% 25V
C1301	1-100-566-11	CERAMIC CHIP 0.1uF	10% 25V	C1472	1-100-566-11	CERAMIC CHIP 0.1uF	10% 25V
C1302	1-162-974-11	CERAMIC CHIP 0.01uF	50V	C1473	1-100-566-11	CERAMIC CHIP 0.1uF	10% 25V
C1303	1-100-566-11	CERAMIC CHIP 0.1uF	10% 25V	C1474	1-100-566-11	CERAMIC CHIP 0.1uF	10% 25V
C1304	1-107-726-11	CERAMIC CHIP 0.01uF	16V	C1475	1-100-566-11	CERAMIC CHIP 0.1uF	10% 25V
C1305	1-100-566-11	CERAMIC CHIP 0.1uF	10% 25V	C1478	1-126-964-11	ELECT 10uF	20% 50V
C1306	1-126-947-11	ELECT 47uF	20% 35V	C1481	1-162-961-11	CERAMIC CHIP 330PF	10% 50V
C1308	1-100-566-11	CERAMIC CHIP 0.1uF	10% 25V	C1483	1-162-963-11	CERAMIC CHIP 680PF	10% 50V
C1309	1-162-918-11	CERAMIC CHIP 18PF	5% 50V	C1487	1-162-966-11	CERAMIC CHIP 0.0022uF	10% 50V
C1310	1-162-918-11	CERAMIC CHIP 18PF	5% 50V	C1491	1-126-964-11	ELECT 10uF	20% 50V
				C1494	1-100-566-11	CERAMIC CHIP 0.1uF	10% 25V
				C1495	1-162-960-11	CERAMIC CHIP 220PF	10% 50V
				C1501	1-100-566-11	CERAMIC CHIP 0.1uF	10% 25V

Ref. No.	Part No.	Description		Remark	Ref. No.	Part No.	Description	Remark
C1502	1-100-566-11	CERAMIC CHIP	0.1uF	10%	25V		< DIODE >	
C1503	1-100-566-11	CERAMIC CHIP	0.1uF	10%	25V			
C1504	1-100-566-11	CERAMIC CHIP	0.1uF	10%	25V	D1001	8-719-053-18	DIODE 1SR154-400TE-25
C1505	1-100-566-11	CERAMIC CHIP	0.1uF	10%	25V	D1003	8-719-049-09	DIODE 1SS367-T3SONY
C1506	1-100-566-11	CERAMIC CHIP	0.1uF	10%	25V	D1004	8-719-049-09	DIODE 1SS367-T3SONY
						D1107	8-719-404-50	DIODE MA111-TX
C1507	1-100-566-11	CERAMIC CHIP	0.1uF	10%	25V	D1108	8-719-404-50	DIODE MA111-TX
C1508	1-100-566-11	CERAMIC CHIP	0.1uF	10%	25V			
C1509	1-100-566-11	CERAMIC CHIP	0.1uF	10%	25V	D1109	8-719-404-50	DIODE MA111-TX
C1510	1-100-566-11	CERAMIC CHIP	0.1uF	10%	25V	D1110	8-719-404-50	DIODE MA111-TX
C1511	1-100-566-11	CERAMIC CHIP	0.1uF	10%	25V	D1111	8-719-404-50	DIODE MA111-TX
						D1301	8-719-404-50	DIODE MA111-TX
C1513	1-100-566-11	CERAMIC CHIP	0.1uF	10%	25V	D1302	8-719-404-50	DIODE MA111-TX
C1514	1-100-566-11	CERAMIC CHIP	0.1uF	10%	25V			
C1515	1-126-925-11	ELECT	470uF	20%	10V			
C1516	1-100-566-11	CERAMIC CHIP	0.1uF	10%	25V	D1501	8-719-049-09	DIODE 1SS367-T3SONY
C1517	1-126-925-11	ELECT	470uF	20%	10V	D1502	8-719-049-09	DIODE 1SS367-T3SONY
						D1503	8-719-049-09	DIODE 1SS367-T3SONY
C1518	1-100-566-11	CERAMIC CHIP	0.1uF	10%	25V	D1504	8-719-049-09	DIODE 1SS367-T3SONY
C1519	1-100-566-11	CERAMIC CHIP	0.1uF	10%	25V			< FERRITE BEAD >
C1520	1-100-566-11	CERAMIC CHIP	0.1uF	10%	25V			
C1521	1-162-920-11	CERAMIC CHIP	27PF	5%	50V	FB1101	1-400-862-11	BEAD, FERRITE
C1522	1-162-920-11	CERAMIC CHIP	27PF	5%	50V	FB1302	1-400-862-11	BEAD, FERRITE
						FB1305	1-400-862-11	BEAD, FERRITE
C1525	1-126-925-11	ELECT	470uF	20%	10V	FB1308	1-400-862-11	BEAD, FERRITE
C1547	1-162-966-11	CERAMIC CHIP	0.0022uF	10%	50V	FB1310	1-400-862-11	BEAD, FERRITE
C1557	1-162-966-11	CERAMIC CHIP	0.0022uF	10%	50V			
C1566	1-162-966-11	CERAMIC CHIP	0.0022uF	10%	50V	FB1350	1-400-862-11	BEAD, FERRITE
C1567	1-162-966-11	CERAMIC CHIP	0.0022uF	10%	50V	FB1403	1-400-862-11	BEAD, FERRITE
						FB1405	1-400-862-11	BEAD, FERRITE
C1568	1-162-966-11	CERAMIC CHIP	0.0022uF	10%	50V	FB1452	1-400-862-11	BEAD, FERRITE
C1569	1-162-966-11	CERAMIC CHIP	0.0022uF	10%	50V	FB1453	1-400-862-11	BEAD, FERRITE
C1604	1-100-566-11	CERAMIC CHIP	0.1uF	10%	25V			
C1605	1-100-566-11	CERAMIC CHIP	0.1uF	10%	25V	FB1501	1-400-862-11	BEAD, FERRITE
C1620	1-100-566-11	CERAMIC CHIP	0.1uF	10%	25V	FB1502	1-400-862-11	BEAD, FERRITE
						FB1503	1-400-862-11	BEAD, FERRITE
C1639	1-100-566-11	CERAMIC CHIP	0.1uF	10%	25V (AUS,MY,SP,TH)	FB1504	1-469-670-21	FERRITE, EMI (SMD) (2012) (AUS,MY,SP,TH)
C1905	1-100-566-11	CERAMIC CHIP	0.1uF	10%	25V	FB1505	1-400-862-11	BEAD, FERRITE (AUS,MY,SP,TH)
C1906	1-126-925-11	ELECT	470uF	20%	10V			< IC >
C1908	1-126-925-11	ELECT	470uF	20%	10V			
C1910	1-165-722-11	ELECT	100uF	20%	10V (AUS,MY,SP,TH)	IC1001	8-759-231-53	IC TA7805S
						IC1031	6-705-469-01	IC BA50BC0FP-E2
						IC1101	6-807-491-01	IC MB90F045PF-G-9050-SPE1
C1911	1-100-566-11	CERAMIC CHIP	0.1uF	10%	25V (AUS,MY,SP,TH)	IC1111	6-702-913-01	IC S-80929CNMC-G8ZT2G
						IC1131	6-705-866-01	IC BR24L16FJ-WE2
C1913	1-137-980-11	CERAMIC CHIP	0.47uF	10%	50V			
C1914	1-126-947-11	ELECT	47uF	20%	35V	IC1301	8-759-825-15	IC LC89056W-E
C1919	1-126-965-11	ELECT	22uF	20%	50V (AUS,MY,SP,TH)	IC1303	8-759-096-87	IC TC7WU04FU(TE12R)
						IC1351	6-600-466-01	IC TORX147L(SONY) (DIGITAL VIDEO 2/BD IN (OPTICAL))
C1920	1-100-566-11	CERAMIC CHIP	0.1uF	10%	25V (AUS,MY,SP,TH)	IC1354	6-600-466-01	IC TORX147L(SONY) (DIGITAL SAT IN (OPTICAL))
						IC1401	6-707-608-01	IC PCM1803DBR
C1921	1-100-566-11	CERAMIC CHIP	0.1uF	10%	25V (AUS,MY,SP,TH)			
						IC1403	8-759-710-97	IC NJM4565M-D
						IC1404	8-759-710-97	IC NJM4565M-D
						IC1405	8-759-710-97	IC NJM4565M-D
						IC1406	8-759-710-97	IC NJM4565M-D
						IC1452	6-708-785-01	IC PCM1609APT
CNP503	1-691-770-11	PLUG (MICRO CONNECTOR) 8P						
* CNP505	1-564-510-11	PLUG, CONNECTOR 7P				IC1501	6-705-900-01	IC CXD9718BQ
* CNP512	1-564-506-11	PLUG, CONNECTOR 3P (AUS,MY,SP,TH)				IC1502	6-709-278-01	IC IS61WV6416BL-12TLI
CNS501	1-573-829-11	CONNECTOR, BOARD TO BOARD 15P				IC1503	8-759-546-74	IC TC7WH157FU(TE12R)
CNS502	1-573-825-11	CONNECTOR, BOARD TO BOARD 11P				IC1902	8-759-231-56	IC TA7809S
						IC1903	6-701-887-02	IC SI-3004KWF
CNS504	1-784-731-11	CONNECTOR, FFC 9P						
CNS507	1-568-828-11	CONNECTOR, FFC 9P				IC1904	6-705-468-01	IC BA33BC0FP-E2
CNS509	1-784-774-11	CONNECTOR, FFC 13P				IC1906	6-707-745-10	IC SI-3050KM-TL (AUS,MY,SP,TH)
CNS514	1-784-780-11	CONNECTOR, FFC 19P						

# STR-K1600

Ver. 1.1

DIGITAL

Ref. No.	Part No.	Description	Remark	Ref. No.	Part No.	Description	Remark
		< JACK >					
J1301	1-793-446-21	JACK, PIN 1P (DIGITAL DVD IN (COAXIAL))		R1122	1-216-809-11	METAL CHIP	100 5% 1/10W
		< CONNECTOR >		R1123	1-216-809-11	METAL CHIP	100 5% 1/10W
J1311	1-817-615-21	CONNECTOR, BOARD TO BOARD 18P (DMPORT) (AUS,MY,SP,TH)		R1124	1-216-809-11	METAL CHIP	100 5% 1/10W
		< JUMPER RESISTOR >		R1125	1-216-809-11	METAL CHIP	100 5% 1/10W
JR1002	1-211-950-11	SHORT CHIP	0	R1126	1-216-809-11	METAL CHIP	100 5% 1/10W
JR1005	1-216-864-11	SHORT CHIP	0	R1127	1-216-809-11	METAL CHIP	100 5% 1/10W
JR1008	1-216-864-11	SHORT CHIP	0	R1128	1-216-809-11	METAL CHIP	100 5% 1/10W
JR1020	1-216-864-11	SHORT CHIP	0	R1129	1-216-809-11	METAL CHIP	100 5% 1/10W
JR1511	1-400-862-11	BEAD, FERRITE		R1134	1-216-809-11	METAL CHIP	100 5% 1/10W
		< RESISTOR >		R1135	1-216-809-11	METAL CHIP	100 5% 1/10W
R1010	1-216-809-11	METAL CHIP	100 5% 1/10W	R1140	1-216-809-11	METAL CHIP	100 5% 1/10W
R1011	1-216-809-11	METAL CHIP	100 5% 1/10W	R1143	1-216-809-11	METAL CHIP	100 5% 1/10W
R1012	1-216-809-11	METAL CHIP	100 5% 1/10W	R1144	1-216-809-11	METAL CHIP	100 5% 1/10W
R1013	1-216-809-11	METAL CHIP	100 5% 1/10W	R1150	1-216-809-11	METAL CHIP	100 5% 1/10W
R1014	1-216-809-11	METAL CHIP	100 5% 1/10W	R1151	1-216-809-11	METAL CHIP	100 5% 1/10W
R1015	1-216-809-11	METAL CHIP	100 5% 1/10W	R1152	1-216-809-11	METAL CHIP	100 5% 1/10W
R1035	1-216-825-11	METAL CHIP	2.2K 5% 1/10W	R1153	1-216-809-11	METAL CHIP	100 5% 1/10W
R1039	1-216-833-11	METAL CHIP	10K 5% 1/10W	R1154	1-216-809-11	METAL CHIP	100 5% 1/10W
R1041	1-216-809-11	METAL CHIP	100 5% 1/10W	R1156	1-216-864-11	SHORT CHIP	0
R1042	1-216-809-11	METAL CHIP	100 5% 1/10W	R1157	1-216-864-11	SHORT CHIP	0
R1049	1-216-833-11	METAL CHIP	10K 5% 1/10W	R1159	1-216-827-11	METAL CHIP	3.3K 5% 1/10W
R1050	1-216-809-11	METAL CHIP	100 5% 1/10W (AUS,MY,SP,TH)	R1160	1-216-809-11	METAL CHIP	100 5% 1/10W
R1061	1-216-809-11	METAL CHIP	100 5% 1/10W	R1161	1-216-809-11	METAL CHIP	100 5% 1/10W
R1062	1-216-809-11	METAL CHIP	100 5% 1/10W	R1163	1-216-841-11	METAL CHIP	47K 5% 1/10W
R1065	1-216-809-11	METAL CHIP	100 5% 1/10W	R1164	1-216-829-11	METAL CHIP	4.7K 5% 1/10W
R1066	1-216-809-11	METAL CHIP	100 5% 1/10W	R1175	1-216-809-11	METAL CHIP	100 5% 1/10W
R1067	1-216-809-11	METAL CHIP	100 5% 1/10W	R1179	1-216-833-11	METAL CHIP	10K 5% 1/10W
R1068	1-216-809-11	METAL CHIP	100 5% 1/10W	R1180	1-216-833-11	METAL CHIP	10K 5% 1/10W
R1072	1-216-827-11	METAL CHIP	3.3K 5% 1/10W	R1181	1-216-833-11	METAL CHIP	10K 5% 1/10W
R1073	1-216-827-11	METAL CHIP	3.3K 5% 1/10W	R1182	1-216-833-11	METAL CHIP	10K 5% 1/10W
R1076	1-216-809-11	METAL CHIP	100 5% 1/10W	R1183	1-216-833-11	METAL CHIP	10K 5% 1/10W
R1077	1-216-809-11	METAL CHIP	100 5% 1/10W	R1184	1-216-833-11	METAL CHIP	10K 5% 1/10W
R1078	1-216-809-11	METAL CHIP	100 5% 1/10W	R1185	1-216-833-11	METAL CHIP	10K 5% 1/10W
R1083	1-216-833-11	METAL CHIP	10K 5% 1/10W	R1186	1-216-833-11	METAL CHIP	10K 5% 1/10W
R1084	1-216-809-11	METAL CHIP	100 5% 1/10W	R1187	1-216-833-11	METAL CHIP	10K 5% 1/10W
R1088	1-216-833-11	METAL CHIP	10K 5% 1/10W	R1188	1-216-833-11	METAL CHIP	10K 5% 1/10W
R1094	1-216-833-11	METAL CHIP	10K 5% 1/10W	R1189	1-216-833-11	METAL CHIP	10K 5% 1/10W
R1095	1-216-833-11	METAL CHIP	10K 5% 1/10W	R1190	1-216-833-11	METAL CHIP	10K 5% 1/10W
R1096	1-216-833-11	METAL CHIP	10K 5% 1/10W	R1191	1-216-833-11	METAL CHIP	10K 5% 1/10W
R1105	1-216-833-11	METAL CHIP	10K 5% 1/10W	R1192	1-216-833-11	METAL CHIP	10K 5% 1/10W
R1106	1-216-809-11	METAL CHIP	100 5% 1/10W	R1193	1-216-837-11	METAL CHIP	22K 5% 1/10W (AR,MX)
R1107	1-216-825-11	METAL CHIP	2.2K 5% 1/10W	R1193	1-216-841-11	METAL CHIP	47K 5% 1/10W (EXCEPT AR,MX)
R1108	1-216-825-11	METAL CHIP	2.2K 5% 1/10W	R1194	1-216-829-11	METAL CHIP	4.7K 5% 1/10W (AUS,MY,SP,TH)
R1110	1-216-825-11	METAL CHIP	2.2K 5% 1/10W	R1194	1-216-837-11	METAL CHIP	22K 5% 1/10W (E51)
R1111	1-216-825-11	METAL CHIP	2.2K 5% 1/10W	R1194	1-216-841-11	METAL CHIP	47K 5% 1/10W (AR,MX)
R1112	1-216-809-11	METAL CHIP	100 5% 1/10W	R1201	1-216-837-11	METAL CHIP	22K 5% 1/10W
R1114	1-216-825-11	METAL CHIP	2.2K 5% 1/10W	R1253	1-216-833-11	METAL CHIP	10K 5% 1/10W
R1117	1-216-821-11	METAL CHIP	1K 5% 1/10W	R1260	1-216-821-11	METAL CHIP	1K 5% 1/10W
R1118	1-216-821-11	METAL CHIP	1K 5% 1/10W	R1261	1-216-821-11	METAL CHIP	1K 5% 1/10W
R1120	1-216-821-11	METAL CHIP	1K 5% 1/10W	R1301	1-216-830-11	METAL CHIP	5.6K 5% 1/10W
R1121	1-216-809-11	METAL CHIP	100 5% 1/10W	R1302	1-216-829-11	METAL CHIP	4.7K 5% 1/10W
				R1303	1-216-839-11	METAL CHIP	33K 5% 1/10W
				R1304	1-216-809-11	METAL CHIP	100 5% 1/10W
				R1305	1-216-819-11	METAL CHIP	680 5% 1/10W



Ref. No.	Part No.	Description			Remark	Ref. No.	Part No.	Description			Remark
R1306	1-216-801-11	METAL CHIP	22	5%	1/10W	R1491	1-218-867-11	METAL CHIP	6.8K	0.5%	1/10W
R1307	1-216-809-11	METAL CHIP	100	5%	1/10W	R1492	1-218-867-11	METAL CHIP	6.8K	0.5%	1/10W
R1308	1-216-809-11	METAL CHIP	100	5%	1/10W	R1493	1-218-867-11	METAL CHIP	6.8K	0.5%	1/10W
R1309	1-216-809-11	METAL CHIP	100	5%	1/10W	R1494	1-218-867-11	METAL CHIP	6.8K	0.5%	1/10W
R1310	1-216-857-11	METAL CHIP	1M	5%	1/10W	R1495	1-218-867-11	METAL CHIP	6.8K	0.5%	1/10W
R1311	1-216-809-11	METAL CHIP	100	5%	1/10W	R1501	1-216-809-11	METAL CHIP	100	5%	1/10W
R1312	1-216-809-11	METAL CHIP	100	5%	1/10W	R1502	1-216-809-11	METAL CHIP	100	5%	1/10W
R1313	1-216-809-11	METAL CHIP	100	5%	1/10W	R1503	1-216-813-11	METAL CHIP	220	5%	1/10W
R1314	1-216-833-11	METAL CHIP	10K	5%	1/10W	R1504	1-216-809-11	METAL CHIP	100	5%	1/10W
R1318	1-216-833-11	METAL CHIP	10K	5%	1/10W	R1505	1-216-809-11	METAL CHIP	100	5%	1/10W
R1319	1-216-864-11	SHORT CHIP	0			R1506	1-216-809-11	METAL CHIP	100	5%	1/10W
R1321	1-216-864-11	SHORT CHIP	0			R1507	1-216-809-11	METAL CHIP	100	5%	1/10W
R1323	1-216-833-11	METAL CHIP	10K	5%	1/10W	R1508	1-216-809-11	METAL CHIP	100	5%	1/10W
R1325	1-216-864-11	SHORT CHIP	0			R1509	1-216-809-11	METAL CHIP	100	5%	1/10W
R1351	1-216-809-11	METAL CHIP	100	5%	1/10W	R1510	1-216-809-11	METAL CHIP	100	5%	1/10W
R1352	1-216-821-11	METAL CHIP	1K	5%	1/10W (AUS,MY,SP,TH)	R1511	1-216-809-11	METAL CHIP	100	5%	1/10W
R1353	1-216-821-11	METAL CHIP	1K	5%	1/10W (AUS,MY,SP,TH)	R1512	1-216-833-11	METAL CHIP	10K	5%	1/10W
R1354	1-216-809-11	METAL CHIP	100	5%	1/10W	R1513	1-216-833-11	METAL CHIP	10K	5%	1/10W
R1355	1-218-285-11	METAL CHIP	75	5%	1/10W	R1514	1-216-833-11	METAL CHIP	10K	5%	1/10W
R1356	1-216-817-11	METAL CHIP	470	5%	1/10W	R1515	1-216-857-11	METAL CHIP	1M	5%	1/10W
R1357	1-216-841-11	METAL CHIP	47K	5%	1/10W	R1523	1-216-813-11	METAL CHIP	220	5%	1/10W
R1359	1-216-809-11	METAL CHIP	100	5%	1/10W	R1524	1-216-864-11	SHORT CHIP	0		
R1360	1-216-809-11	METAL CHIP	100	5%	1/10W	R1530	1-216-845-11	METAL CHIP	100K	5%	1/10W
R1401	1-216-809-11	METAL CHIP	100	5%	1/10W	R1541	1-216-813-11	METAL CHIP	220	5%	1/10W
R1407	1-216-809-11	METAL CHIP	100	5%	1/10W	R1555	1-216-813-11	METAL CHIP	220	5%	1/10W
R1409	1-216-864-11	SHORT CHIP	0			R1556	1-216-809-11	METAL CHIP	100	5%	1/10W
R1410	1-216-817-11	METAL CHIP	470	5%	1/10W	R1557	1-216-813-11	METAL CHIP	220	5%	1/10W
R1411	1-216-817-11	METAL CHIP	470	5%	1/10W	R1570	1-216-833-11	METAL CHIP	10K	5%	1/10W
R1414	1-218-867-11	METAL CHIP	6.8K	0.5%	1/10W	R1571	1-216-833-11	METAL CHIP	10K	5%	1/10W
R1416	1-216-821-11	METAL CHIP	1K	5%	1/10W	R1572	1-216-833-11	METAL CHIP	10K	5%	1/10W
R1421	1-218-867-11	METAL CHIP	6.8K	0.5%	1/10W	R1573	1-216-833-11	METAL CHIP	10K	5%	1/10W
R1424	1-218-867-11	METAL CHIP	6.8K	0.5%	1/10W	R1574	1-216-833-11	METAL CHIP	10K	5%	1/10W
R1425	1-216-864-11	SHORT CHIP	0			R1602	1-216-864-11	SHORT CHIP	0		
R1426	1-216-821-11	METAL CHIP	1K	5%	1/10W	R1635	1-216-833-11	METAL CHIP	10K	5%	1/10W
R1434	1-218-867-11	METAL CHIP	6.8K	0.5%	1/10W	R1636	1-216-833-11	METAL CHIP	10K	5%	1/10W
R1435	1-216-864-11	SHORT CHIP	0			R1637	1-216-864-11	SHORT CHIP	0 (AUS,MY,SP,TH)		
R1436	1-216-821-11	METAL CHIP	1K	5%	1/10W	R1640	1-216-833-11	METAL CHIP	10K	5%	1/10W
R1444	1-218-867-11	METAL CHIP	6.8K	0.5%	1/10W	R1643	1-216-833-11	METAL CHIP	10K	5%	1/10W
R1445	1-216-864-11	SHORT CHIP	0			R1644	1-216-833-11	METAL CHIP	10K	5%	1/10W
R1446	1-216-821-11	METAL CHIP	1K	5%	1/10W	R1645	1-216-833-11	METAL CHIP	10K	5%	1/10W
R1454	1-218-867-11	METAL CHIP	6.8K	0.5%	1/10W	R1940	1-216-864-11	SHORT CHIP	0 (AUS,MY,SP,TH)		
R1455	1-216-864-11	SHORT CHIP	0			R1941	1-216-833-11	METAL CHIP	10K	5%	1/10W (AUS,MY,SP,TH)
R1460	1-216-864-11	SHORT CHIP	0			R1943	1-216-841-11	METAL CHIP	47K	5%	1/10W
R1461	1-216-864-11	SHORT CHIP	0								
R1463	1-218-867-11	METAL CHIP	6.8K	0.5%	1/10W			< NETWORK RESISTOR >			
R1464	1-216-864-11	SHORT CHIP	0			RB1500	1-233-576-11	RES, CHIP NETWORK 100X4 (3216)			
R1466	1-216-821-11	METAL CHIP	1K	5%	1/10W	RB1501	1-233-576-11	RES, CHIP NETWORK 100X4 (3216)			
R1469	1-216-809-11	METAL CHIP	100	5%	1/10W	RB1502	1-233-576-11	RES, CHIP NETWORK 100X4 (3216)			
R1470	1-216-832-11	METAL CHIP	8.2K	5%	1/10W	RB1503	1-233-576-11	RES, CHIP NETWORK 100X4 (3216)			
R1473	1-216-832-11	METAL CHIP	8.2K	5%	1/10W	RB1504	1-233-576-11	RES, CHIP NETWORK 100X4 (3216)			
R1474	1-216-833-11	METAL CHIP	10K	5%	1/10W	RB1506	1-233-576-11	RES, CHIP NETWORK 100X4 (3216)			
R1476	1-216-821-11	METAL CHIP	1K	5%	1/10W	RB1507	1-233-576-11	RES, CHIP NETWORK 100X4 (3216)			
R1483	1-218-867-11	METAL CHIP	6.8K	0.5%	1/10W	RB1508	1-233-576-11	RES, CHIP NETWORK 100X4 (3216)			
R1484	1-216-864-11	SHORT CHIP	0					< VIBRATOR >			
R1486	1-216-821-11	METAL CHIP	1K	5%	1/10W	X1101	1-813-448-21	PIEZOELECTRIC OSCILLATOR (24MHZ)			
R1490	1-218-867-11	METAL CHIP	6.8K	0.5%	1/10W	X1301	1-795-126-21	VIBRATOR, CRYSTAL (12.288MHZ)			

# STR-K1600

Ver. 1.1

**DIGITAL**   **DISPLAY**   **HDMI SW**

Ref. No.	Part No.	Description	Remark
X1502	1-813-276-21	QUARTZ, CRYSTAL (13.9MHz)	
*****			
	A-1223-145-A	DISPLAY BOARD, COMPLETE (EXCEPT E51,MX)	
	A-1223-147-A	DISPLAY BOARD, COMPLETE (E51)	
	A-1251-515-A	DISPLAY BOARD, COMPLETE (MX)	
*****			
< CAPACITOR >			
C110	1-162-286-31	CERAMIC	220PF 10% 50V
C111	1-162-286-31	CERAMIC	220PF 10% 50V
C112	1-162-286-31	CERAMIC	220PF 10% 50V
C114	1-127-888-11	CERAMIC	0.1uF 10% 50V
C115	1-126-964-11	ELECT	10uF 20% 50V
C144	1-127-888-11	CERAMIC	0.1uF 10% 50V
C145	1-127-888-11	CERAMIC	0.1uF 10% 50V
C147	1-162-286-31	CERAMIC	220PF 10% 50V
C148	1-126-964-11	ELECT	10uF 20% 50V
C149	1-162-286-31	CERAMIC	220PF 10% 50V
C160	1-127-888-11	CERAMIC	0.1uF 10% 50V
C162	1-127-888-11	CERAMIC	0.1uF 10% 50V
C164	1-162-286-31	CERAMIC	220PF 10% 50V
C165	1-126-964-11	ELECT	10uF 20% 50V
< CONNECTOR >			
* CN104	1-691-746-11	CONNECTOR, BOARD TO BOARD 5P	
CNP106	1-564-718-11	PIN, CONNECTOR (SMALL TYPE) 2P	
CNS101	1-784-780-11	CONNECTOR, FFC 19P	
< DIODE >			
D105	6-501-539-01	LED SELK5E20C-DTP15 (MULTI CHANNEL DECODING)	
< VACUUM FLUORESCENT DISPLAY >			
FL101	1-519-927-11	VACUUM FLUORESCENT DISPLAY	
< IC >			
IC100	8-759-643-83	IC uPD16315GB-3BS	
IC101	8-759-243-51	IC TC74ACT08P	
IC103	6-600-349-31	IC NJL24H400A (IR)	
< TRANSISTOR >			
Q110	8-729-119-78	TRANSISTOR 2SC2785-HFE	
< RESISTOR >			
R101	1-249-409-11	CARBON	220 5% 1/4W
R102	1-249-411-11	CARBON	330 5% 1/4W
R103	1-249-413-11	CARBON	470 5% 1/4W
R104	1-249-415-11	CARBON	680 5% 1/4W
R105	1-247-831-11	CARBON	1K 5% 1/4W
R106	1-249-419-11	CARBON	1.5K 5% 1/4W
R107	1-249-421-11	CARBON	2.2K 5% 1/4W
R108	1-249-409-11	CARBON	220 5% 1/4W
R109	1-249-411-11	CARBON	330 5% 1/4W
R110	1-249-413-11	CARBON	470 5% 1/4W
R115	1-247-807-31	CARBON	100 5% 1/4W
R116	1-247-807-31	CARBON	100 5% 1/4W
R117	1-247-807-31	CARBON	100 5% 1/4W

Ref. No.	Part No.	Description	Remark
R118	1-249-440-11	CARBON	82K 5% 1/4W
R119	1-247-807-31	CARBON	100 5% 1/4W
R120	1-249-393-11	CARBON	10 5% 1/4W F
R122	1-247-804-11	CARBON	75 5% 1/4W
R131	1-249-421-11	CARBON	2.2K 5% 1/4W
R197	1-249-384-11	CARBON	1.8 5% 1/4W F
R198	1-249-384-11	CARBON	1.8 5% 1/4W F
< ROTARY ENCODER >			
RV101	1-418-817-11	ENCODER, ROTARY (INPUT SELECTOR)	
RV102	1-418-725-41	ENCODER, ROTARY (12 TYPE) (MASTER VOLUME)	
< SWITCH >			
S101	1-771-410-21	SWITCH, TACTILE (X-ROUND SPEED)	
S102	1-771-410-21	SWITCH, TACTILE (X-ROUND MODE)	
S103	1-771-410-21	SWITCH, TACTILE (INPUT MODE)	
S104	1-771-410-21	SWITCH, TACTILE (DISPLAY)	
S105	1-771-410-21	SWITCH, TACTILE (MUSIC)	
S106	1-771-410-21	SWITCH, TACTILE (MOVIE)	
S107	1-771-410-21	SWITCH, TACTILE (A.F.D.)	
S108	1-771-410-21	SWITCH, TACTILE (2CH)	
S109	1-771-410-21	SWITCH, TACTILE (SUR BACK DECODING)	
S110	1-771-410-21	SWITCH, TACTILE (SLEEP)	
S111	1-771-410-21	SWITCH, TACTILE (DIMMER)	
S112	1-771-410-21	SWITCH, TACTILE (MEMORY/ENTER)	
*****			
A-1158-394-A		HDMI SW BOARD, COMPLETE (EXCEPT MX)	
A-1251-524-A		HDMI SW BOARD, COMPLETE (MX)	
*****			
< CAPACITOR >			
C5001	1-107-826-11	CERAMIC CHIP	0.1uF 10% 16V
C5002	1-162-970-11	CERAMIC CHIP	0.01uF 10% 25V
C5003	1-162-970-11	CERAMIC CHIP	0.01uF 10% 25V
C5004	1-162-970-11	CERAMIC CHIP	0.01uF 10% 25V
C5005	1-162-970-11	CERAMIC CHIP	0.01uF 10% 25V
C5006	1-162-970-11	CERAMIC CHIP	0.01uF 10% 25V
C5007	1-162-970-11	CERAMIC CHIP	0.01uF 10% 25V
C5008	1-162-970-11	CERAMIC CHIP	0.01uF 10% 25V
C5009	1-162-970-11	CERAMIC CHIP	0.01uF 10% 25V
C5010	1-162-970-11	CERAMIC CHIP	0.01uF 10% 25V
C5011	1-162-970-11	CERAMIC CHIP	0.01uF 10% 25V
C5012	1-112-788-11	ELECT CHIP	330uF 20% 6.3V
C5013	1-128-934-11	CERAMIC CHIP	0.33uF 20% 10V
C5014	1-112-788-11	ELECT CHIP	330uF 20% 6.3V
C5015	1-128-994-21	ELECT CHIP	47uF 20% 10V
C5016	1-162-970-11	CERAMIC CHIP	0.01uF 10% 25V
C5017	1-115-467-11	CERAMIC CHIP	0.22uF 10% 10V
C5018	1-115-467-11	CERAMIC CHIP	0.22uF 10% 10V
C5019	1-107-826-11	CERAMIC CHIP	0.1uF 10% 16V
C5020	1-107-826-11	CERAMIC CHIP	0.1uF 10% 16V
C5021	1-117-681-11	ELECT CHIP	100uF 20% 16V
C5022	1-162-970-11	CERAMIC CHIP	0.01uF 10% 25V
C5023	1-162-970-11	CERAMIC CHIP	0.01uF 10% 25V
C5024	1-128-934-11	CERAMIC CHIP	0.33uF 20% 10V
C5027	1-128-994-21	ELECT CHIP	47uF 20% 10V

Ref. No.	Part No.	Description	Remark	Ref. No.	Part No.	Description	Remark
		< CONNECTOR >					
CN5001	1-820-735-11	CONNECTOR, HDMI 19P (HDMI DVD IN)		R5061	1-216-864-11	SHORT CHIP 0	
CN5002	1-820-735-11	CONNECTOR, HDMI 19P (HDMI VIDEO 2/BD IN)		R5068	1-216-845-11	METAL CHIP 100K 5%	1/10W
CN5003	1-820-735-11	CONNECTOR, HDMI 19P (HDMI OUT)		R5069	1-216-845-11	METAL CHIP 100K 5%	1/10W
* CN5004	1-770-470-21	PIN, CONNECTOR (PC BOARD) 6P		R5072	1-216-809-11	METAL CHIP 100 5%	1/10W
		< IC >		R5073	1-216-864-11	SHORT CHIP 0	
IC5001	6-709-221-01	IC TMDS341PFCR		R5074	1-216-825-11	METAL CHIP 2.2K 5%	1/10W
IC5002	6-705-337-01	IC TK11150CSCL-G		*****			
IC5003	6-705-468-01	IC BA33BC0FP-E2		HEADPHONE BOARD			
IC5004	6-704-099-01	IC TC7WZ08FK(TE85R)		*****			
IC5005	6-707-207-01	IC SN74LVC1G3157DCKR		< CAPACITOR >			
IC5006	6-706-740-01	IC BA00BC0WFP-E2		C790	1-127-888-11	CERAMIC 0.1uF 10%	50V
		< FERRITE BEAD >		C791	1-127-888-11	CERAMIC 0.1uF 10%	50V
L5013	1-400-862-11	BEAD, FERRITE		< CONNECTOR >			
		< RESISTOR >		* CNP790	1-564-508-11	PLUG, CONNECTOR 5P	
R5001	1-218-861-11	METAL CHIP 3.9K	0.5%			< JACK >	
R5002	1-218-844-11	METAL CHIP 750	0.5%	J790	1-815-314-21	JACK (PHONES)	
R5003	1-216-833-11	METAL CHIP 10K	5%			< LEAD WIRE >	
R5004	1-216-864-11	SHORT CHIP 0		* TP790	1-690-880-31	LEAD (WITH CONNECTOR)	
R5005	1-216-864-11	SHORT CHIP 0		*****			
R5006	1-216-864-11	SHORT CHIP 0		A-1223-131-A	MAIN BOARD, COMPLETE (MY,SP,TH)		
R5007	1-216-864-11	SHORT CHIP 0		A-1223-132-A	MAIN BOARD, COMPLETE (AUS)		
R5008	1-216-864-11	SHORT CHIP 0		A-1223-133-A	MAIN BOARD, COMPLETE (E51,AR)		
R5009	1-216-864-11	SHORT CHIP 0		A-1251-510-A	MAIN BOARD, COMPLETE (MX)		
R5010	1-216-864-11	SHORT CHIP 0		*****			
R5011	1-216-864-11	SHORT CHIP 0		7-685-646-79	SCREW +BVTP 3X8 TYPE2 IT-3		
R5014	1-216-864-11	SHORT CHIP 0		< CAPACITOR >			
R5015	1-216-821-11	METAL CHIP 1K	5%	C400	1-162-966-11	CERAMIC CHIP 0.0022uF 10%	50V
R5016	1-216-864-11	SHORT CHIP 0		C403	1-162-966-11	CERAMIC CHIP 0.0022uF 10%	50V
R5017	1-216-864-11	SHORT CHIP 0		C408	1-126-963-11	ELECT 4.7uF 20%	50V
R5018	1-216-821-11	METAL CHIP 1K	5%	C409	1-126-963-11	ELECT 4.7uF 20%	50V
R5019	1-216-864-11	SHORT CHIP 0		C444	1-162-966-11	CERAMIC CHIP 0.0022uF 10%	50V
R5020	1-216-864-11	SHORT CHIP 0		C453	1-162-960-11	CERAMIC CHIP 220PF 10%	50V
R5022	1-216-833-11	METAL CHIP 10K	5%	C458	1-126-963-11	ELECT 4.7uF 20%	50V
R5024	1-216-864-11	SHORT CHIP 0		C459	1-126-963-11	ELECT 4.7uF 20%	50V
R5025	1-216-864-11	SHORT CHIP 0		C463	1-162-960-11	CERAMIC CHIP 220PF 10%	50V
R5026	1-216-809-11	METAL CHIP 100	5%	C464	1-164-156-11	CERAMIC CHIP 0.1uF	25V
R5027	1-216-833-11	METAL CHIP 10K	5%	C468	1-162-927-11	CERAMIC CHIP 100PF 5%	50V
R5028	1-216-833-11	METAL CHIP 10K	5%	C469	1-162-927-11	CERAMIC CHIP 100PF 5%	50V
R5029	1-216-841-11	METAL CHIP 47K	5%	C471	1-126-963-11	ELECT 4.7uF 20%	50V
R5030	1-216-833-11	METAL CHIP 10K	5%	C481	1-126-964-11	ELECT 10uF 20%	50V
R5042	1-216-829-11	METAL CHIP 4.7K	5%	C484	1-126-964-11	ELECT 10uF 20%	50V
R5043	1-216-829-11	METAL CHIP 4.7K	5%	C485	1-126-964-11	ELECT 10uF 20%	50V
R5047	1-216-864-11	SHORT CHIP 0		C488	1-164-156-11	CERAMIC CHIP 0.1uF	25V
R5048	1-216-864-11	SHORT CHIP 0		C490	1-126-964-11	ELECT 10uF 20%	50V
R5049	1-216-864-11	SHORT CHIP 0		C492	1-126-964-11	ELECT 10uF 20%	50V
R5050	1-216-821-11	METAL CHIP 1K	5%	C493	1-126-964-11	ELECT 10uF 20%	50V
R5051	1-216-823-11	METAL CHIP 1.5K	5%	C495	1-126-964-11	ELECT 10uF 20%	50V
R5052	1-216-841-11	METAL CHIP 47K	5%	C501	1-126-963-11	ELECT 4.7uF 20%	50V
R5053	1-216-825-11	METAL CHIP 2.2K	5%	C503	1-165-722-11	ELECT 100uF 20%	10V
R5054	1-216-833-11	METAL CHIP 10K	5%	C504	1-107-583-11	CERAMIC 3PF 0.25PF	500V
R5055	1-216-833-11	METAL CHIP 10K	5%	C505	1-102-233-00	CERAMIC 33PF 10%	500V
R5056	1-216-821-11	METAL CHIP 1K	5%				
R5060	1-216-864-11	SHORT CHIP 0					

# STR-K1600

Ver. 1.1

MAIN

Ref. No.	Part No.	Description			Remark	Ref. No.	Part No.	Description			Remark
C506	1-162-927-11	CERAMIC CHIP	100PF	5%	50V	C711	1-136-157-00	FILM	0.022uF	5%	50V
C507	1-162-927-11	CERAMIC CHIP	100PF	5%	50V	C716	1-162-815-11	CERAMIC	47PF	5%	500V
C510	1-126-947-11	ELECT	47uF	20%	35V	C717	1-162-815-11	CERAMIC	47PF	5%	500V
C511	1-136-157-00	FILM	0.022uF	5%	50V	C720	1-162-960-11	CERAMIC CHIP	220PF	10%	50V
C516	1-162-815-11	CERAMIC	47PF	5%	500V	C721	1-126-923-11	ELECT	220uF	20%	10V
C517	1-162-815-11	CERAMIC	47PF	5%	500V	C722	1-126-964-11	ELECT	10uF	20%	50V
C519	1-162-960-11	CERAMIC CHIP	220PF	10%	50V	C729	1-162-970-11	CERAMIC CHIP	0.01uF	10%	25V
C529	1-162-970-11	CERAMIC CHIP	0.01uF	10%	25V	C732	1-128-582-11	ELECT	10uF	20%	100V
C531	1-136-157-00	FILM	0.022uF	5%	50V	C733	1-128-582-11	ELECT	10uF	20%	100V
C539	1-162-960-11	CERAMIC CHIP	220PF	10%	50V	C740	1-126-964-11	ELECT	10uF	20%	50V
C540	1-126-964-11	ELECT	10uF	20%	50V	C741	1-128-579-11	ELECT	2.2uF	20%	100V
C541	1-162-970-11	CERAMIC CHIP	0.01uF	10%	25V	C742	1-162-970-11	CERAMIC CHIP	0.01uF	10%	25V
C553	1-165-722-11	ELECT	100uF	20%	10V	C743	1-128-579-11	ELECT	2.2uF	20%	100V
C554	1-107-583-11	CERAMIC	3PF	0.25PF	500V	C744	1-128-579-11	ELECT	2.2uF	20%	100V
C561	1-126-963-11	ELECT	4.7uF	20%	50V	C749	1-162-970-11	CERAMIC CHIP	0.01uF	10%	25V
C565	1-102-233-00	CERAMIC	33PF	10%	500V	C750	1-126-964-11	ELECT	10uF	20%	50V
C566	1-162-927-11	CERAMIC CHIP	100PF	5%	50V	C751	1-126-963-11	ELECT	4.7uF	20%	50V
C567	1-162-927-11	CERAMIC CHIP	100PF	5%	50V	C752	1-162-970-11	CERAMIC CHIP	0.01uF	10%	25V
C570	1-126-947-11	ELECT	47uF	20%	35V	C753	1-165-722-11	ELECT	100uF	20%	10V
C576	1-162-815-11	CERAMIC	47PF	5%	500V	C754	1-107-583-11	CERAMIC	3PF	0.25PF	500V
C577	1-162-815-11	CERAMIC	47PF	5%	500V	C755	1-102-233-00	CERAMIC	33PF	10%	500V
C580	1-126-964-11	ELECT	10uF	20%	50V	C756	1-162-927-11	CERAMIC CHIP	100PF	5%	50V
C581	1-162-970-11	CERAMIC CHIP	0.01uF	10%	25V	C757	1-162-927-11	CERAMIC CHIP	100PF	5%	50V
C601	1-126-963-11	ELECT	4.7uF	20%	50V	C760	1-126-947-11	ELECT	47uF	20%	35V
C603	1-165-722-11	ELECT	100uF	20%	10V	C761	1-136-157-00	FILM	0.022uF	5%	50V
C604	1-107-583-11	CERAMIC	3PF	0.25PF	500V	C762	1-126-964-11	ELECT	10uF	20%	50V
C605	1-102-233-00	CERAMIC	33PF	10%	500V	C766	1-162-815-11	CERAMIC	47PF	5%	500V
C606	1-162-927-11	CERAMIC CHIP	100PF	5%	50V	C767	1-162-815-11	CERAMIC	47PF	5%	500V
C607	1-162-927-11	CERAMIC CHIP	100PF	5%	50V	C770	1-162-960-11	CERAMIC CHIP	220PF	10%	50V
C610	1-126-947-11	ELECT	47uF	20%	35V	C791	1-126-923-11	ELECT	220uF	20%	10V
C611	1-136-157-00	FILM	0.022uF	5%	50V	C801	1-126-947-11	ELECT	47uF	20%	35V
C619	1-162-960-11	CERAMIC CHIP	220PF	10%	50V	C802	1-126-947-11	ELECT	47uF	20%	35V
C620	1-162-815-11	CERAMIC	47PF	5%	500V	C803	1-165-960-11	ELECT(BLOCK)	6800uF	20%	71V
C621	1-162-815-11	CERAMIC	47PF	5%	500V	C804	1-165-960-11	ELECT(BLOCK)	6800uF	20%	71V
C640	1-126-964-11	ELECT	10uF	20%	50V	C805	1-135-851-21	MYLAR	0.22uF		100V
C642	1-162-970-11	CERAMIC CHIP	0.01uF	10%	25V	C806	1-135-851-21	MYLAR	0.22uF		100V
C651	1-126-963-11	ELECT	4.7uF	20%	50V	C807	1-126-947-11	ELECT	47uF	20%	35V
C653	1-165-722-11	ELECT	100uF	20%	10V	C808	1-126-947-11	ELECT	47uF	20%	35V
C654	1-107-583-11	CERAMIC	3PF	0.25PF	500V	C809	1-100-623-11	CERAMIC CHIP	0.1uF	10%	100V
C655	1-102-233-00	CERAMIC	33PF	10%	500V	C810	1-137-980-11	CERAMIC CHIP	0.47uF	10%	50V
C656	1-162-927-11	CERAMIC CHIP	100PF	5%	50V	C811	1-137-980-11	CERAMIC CHIP	0.47uF	10%	50V
C657	1-162-927-11	CERAMIC CHIP	100PF	5%	50V	C822	1-126-947-11	ELECT	47uF	20%	35V
C660	1-126-947-11	ELECT	47uF	20%	35V	C830	1-137-980-11	CERAMIC CHIP	0.47uF	10%	50V
C661	1-136-157-00	FILM	0.022uF	5%	50V	C831	1-137-980-11	CERAMIC CHIP	0.47uF	10%	50V
C666	1-162-815-11	CERAMIC	47PF	5%	500V	C832	1-126-936-11	ELECT	3300uF	20%	16V
C669	1-162-815-11	CERAMIC	47PF	5%	500V	C842	1-165-732-31	ELECT	47uF	20%	25V
C670	1-162-960-11	CERAMIC CHIP	220PF	10%	50V	C3003	1-162-923-11	CERAMIC CHIP	47PF	5%	50V
C680	1-126-964-11	ELECT	10uF	20%	50V	C3005	1-126-963-11	ELECT	4.7uF	20%	50V
C681	1-162-970-11	CERAMIC CHIP	0.01uF	10%	25V	C3006	1-164-156-11	CERAMIC CHIP	0.1uF		25V
C691	1-164-156-11	CERAMIC CHIP	0.1uF		25V	C3007	1-164-156-11	CERAMIC CHIP	0.1uF		25V
C701	1-126-963-11	ELECT	4.7uF	20%	50V	C3008	1-126-947-11	ELECT	47uF	20%	35V
C702	1-126-964-11	ELECT	10uF	20%	50V	C3009	1-126-947-11	ELECT	47uF	20%	35V
C703	1-165-722-11	ELECT	100uF	20%	10V	C3010	1-164-156-11	CERAMIC CHIP	0.1uF		25V
C704	1-107-583-11	CERAMIC	3PF	0.25PF	500V	C3011	1-164-156-11	CERAMIC CHIP	0.1uF		25V
C705	1-102-233-00	CERAMIC	33PF	10%	500V	C3012	1-164-156-11	CERAMIC CHIP	0.1uF		25V
C706	1-162-927-11	CERAMIC CHIP	100PF	5%	50V	C3013	1-164-156-11	CERAMIC CHIP	0.1uF		25V
C707	1-162-927-11	CERAMIC CHIP	100PF	5%	50V	C3022	1-165-908-11	CERAMIC CHIP	1uF	10%	10V
C710	1-126-947-11	ELECT	47uF	20%	35V						(AUS,MY,SP,TH)

Ref. No.	Part No.	Description	Remark	Ref. No.	Part No.	Description	Remark
C3024	1-126-963-11	ELECT	4.7uF 20% 50V (AUS,MY,SP,TH)	CNP501	1-573-847-11	CONNECTOR, BOARD TO BOARD 15P	
C3025	1-164-156-11	CERAMIC CHIP	0.1uF 25V (AUS,MY,SP,TH)	* CNP503	1-564-506-11	PLUG, CONNECTOR 3P	
C3026	1-164-156-11	CERAMIC CHIP	0.1uF 25V (AUS,MY,SP,TH)	* CNP507	1-564-507-11	PLUG, CONNECTOR 4P	
C3027	1-165-908-11	CERAMIC CHIP	1uF 10% 10V (AUS,MY,SP,TH)	* CNP801	1-564-242-00	PIN, CONNECTOR (3.96mm PITCH) 5P	
C3032	1-165-908-11	CERAMIC CHIP	1uF 10% 10V (AUS,MY,SP,TH)	* CNP802	1-564-509-11	PLUG, CONNECTOR 6P	
C3034	1-126-963-11	ELECT	4.7uF 20% 50V (AUS,MY,SP,TH)	* CNP912	1-564-506-11	PLUG, CONNECTOR 3P	
C3037	1-165-908-11	CERAMIC CHIP	1uF 10% 10V (AUS,MY,SP,TH)			< DIODE >	
CC02	1-162-927-11	CERAMIC CHIP	100PF 5% 50V (AUS)	D505	6-501-193-01	DIODE 1SS355WTE-17	
CC04	1-162-927-11	CERAMIC CHIP	100PF 5% 50V (AUS)	D529	6-501-193-01	DIODE 1SS355WTE-17	
CC05	1-162-927-11	CERAMIC CHIP	100PF 5% 50V (AUS)	D540	6-501-193-01	DIODE 1SS355WTE-17	
CC06	1-162-927-11	CERAMIC CHIP	100PF 5% 50V (AUS)	D560	6-501-193-01	DIODE 1SS355WTE-17	
CC07	1-162-927-11	CERAMIC CHIP	100PF 5% 50V (AUS)	D580	6-501-193-01	DIODE 1SS355WTE-17	
CC08	1-162-927-11	CERAMIC CHIP	100PF 5% 50V (AUS)	D585	6-501-193-01	DIODE 1SS355WTE-17	
CC09	1-162-927-11	CERAMIC CHIP	100PF 5% 50V (AUS)	D605	6-501-193-01	DIODE 1SS355WTE-17	
CC10	1-162-970-11	CERAMIC CHIP	0.01uF 10% 25V (AUS)	D610	6-501-193-01	DIODE 1SS355WTE-17	
CC11	1-162-970-11	CERAMIC CHIP	0.01uF 10% 25V (AUS)	D611	6-501-193-01	DIODE 1SS355WTE-17	
CC12	1-162-970-11	CERAMIC CHIP	0.01uF 10% 25V (AUS)	D640	6-501-193-01	DIODE 1SS355WTE-17	
CC13	1-162-970-11	CERAMIC CHIP	0.01uF 10% 25V (AUS)	D665	6-501-193-01	DIODE 1SS355WTE-17	
CC15	1-162-970-11	CERAMIC CHIP	0.01uF 10% 25V (AUS)	D680	6-501-193-01	DIODE 1SS355WTE-17	
CC16	1-162-970-11	CERAMIC CHIP	0.01uF 10% 25V (AUS)	D690	8-719-083-71	DIODE UDZSTE-1730B	
CC17	1-162-970-11	CERAMIC CHIP	0.01uF 10% 25V (AUS)	D691	6-501-193-01	DIODE 1SS355WTE-17	
CC18	1-162-970-11	CERAMIC CHIP	0.01uF 10% 25V (AUS)	D705	6-501-193-01	DIODE 1SS355WTE-17	
CC52	1-162-927-11	CERAMIC CHIP	100PF 5% 50V (AUS)	D710	6-501-193-01	DIODE 1SS355WTE-17	
CC54	1-162-927-11	CERAMIC CHIP	100PF 5% 50V (AUS)	D721	6-501-193-01	DIODE 1SS355WTE-17	
CC55	1-162-927-11	CERAMIC CHIP	100PF 5% 50V (AUS)	D722	6-501-193-01	DIODE 1SS355WTE-17	
CC56	1-162-927-11	CERAMIC CHIP	100PF 5% 50V (AUS)	D729	6-501-193-01	DIODE 1SS355WTE-17	
CC57	1-162-927-11	CERAMIC CHIP	100PF 5% 50V (AUS)	D732	6-501-193-01	DIODE 1SS355WTE-17	
CC58	1-162-927-11	CERAMIC CHIP	100PF 5% 50V (AUS)	D733	6-501-193-01	DIODE 1SS355WTE-17	
CC59	1-162-927-11	CERAMIC CHIP	100PF 5% 50V (AUS)	D740	6-501-193-01	DIODE 1SS355WTE-17	
		< CONNECTOR >		D749	6-501-193-01	DIODE 1SS355WTE-17	
CN500	1-573-843-11	CONNECTOR, BOARD TO BOARD 11P		D750	6-501-193-01	DIODE 1SS355WTE-17	
CN506	1-779-978-11	PIN, CONNECTOR 3P		D765	6-501-193-01	DIODE 1SS355WTE-17	
CN3001	1-820-048-11	CONNECTOR (LIGHTING) (D-LIGHT SYNC OUT)		D791	6-501-193-01	DIODE 1SS355WTE-17	
				D801	8-719-083-85	DIODE UDZSTE-1722B	
				D802	8-719-081-52	DIODE D5SBA20-4003	
				D804	6-500-295-01	DIODE PTZ-TE25-5.6B	
				D805	8-719-053-18	DIODE 1SR154-400TE-25	
				D806	8-719-053-18	DIODE 1SR154-400TE-25	
				D807	8-719-053-18	DIODE 1SR154-400TE-25	
				D808	8-719-053-18	DIODE 1SR154-400TE-25	
				D841	6-500-696-01	DIODE UDZSTE-173.0B	
				D896	8-719-053-18	DIODE 1SR154-400TE-25	
				D3001	8-719-069-54	DIODE UDZSTE-175.1B	
						< IC >	
				IC401	6-707-362-01	IC BD3451KS	
				IC501	6-700-943-01	IC uPC2581V-S	
				IC601	6-700-943-01	IC uPC2581V-S	
				IC691	8-759-710-97	IC NJM4565M-D	
				IC701	6-700-943-01	IC uPC2581V-S	
				IC801	8-759-071-48	IC TA7807S	
				IC802	8-759-071-47	IC TA79007S	
				IC3001	8-759-710-97	IC NJM4565M-D	
				IC3002	8-759-710-97	IC NJM4565M-D (AUS,MY,SP,TH)	

## STR-K1600

Ver. 1.1

MAIN

Ref. No.	Part No.	Description	Remark	Ref. No.	Part No.	Description	Remark
		< JACK >					
J308	1-820-948-11	JACK, PIN 4P (SUB WOOFER AUDIO OUT)		Q795	8-729-216-31	TRANSISTOR 2SA1163-G	
J402	1-770-614-11	JACK, PIN 4P (VIDEO 1 AUDIO OUT/AUDIO IN)		Q801	8-729-140-97	TRANSISTOR 2SB734-34	
J403	1-770-614-11	JACK, PIN 4P (SAT AUDIO IN,DVD AUDIO IN)		Q3001	8-729-281-53	TRANSISTOR 2SC1815-GR	
J405	1-774-411-11	JACK, PIN 6P (SA-CD/CD/CD-R OUT/IN,TV IN)				< RESISTOR >	
		< COIL >		R402	1-216-821-11	METAL CHIP 1K	5% 1/10W
L501	1-420-872-52	COIL, AIR-CORE		R404	1-216-821-11	METAL CHIP 1K	5% 1/10W
L551	1-420-872-52	COIL, AIR-CORE		R405	1-216-821-11	METAL CHIP 1K	5% 1/10W
L601	1-420-872-52	COIL, AIR-CORE		R406	1-216-821-11	METAL CHIP 1K	5% 1/10W
L651	1-420-872-52	COIL, AIR-CORE		R407	1-216-821-11	METAL CHIP 1K	5% 1/10W
L701	1-420-872-52	COIL, AIR-CORE		R408	1-216-821-11	METAL CHIP 1K	5% 1/10W
L751	1-420-872-52	COIL, AIR-CORE		R409	1-216-821-11	METAL CHIP 1K	5% 1/10W
L3001	1-412-058-11	INDUCTOR 10uH		R423	1-216-864-11	SHORT CHIP 0	
		< TRANSISTOR >		R428	1-216-821-11	METAL CHIP 1K	5% 1/10W
Q501	8-729-119-76	TRANSISTOR 2SA1175-HFE		R429	1-216-821-11	METAL CHIP 1K	5% 1/10W
Q502	8-729-141-30	TRANSISTOR 2SC3623A-LK		R452	1-216-821-11	METAL CHIP 1K	5% 1/10W
Q505	8-729-216-31	TRANSISTOR 2SA1163-G		R454	1-216-821-11	METAL CHIP 1K	5% 1/10W
Q506	8-729-216-31	TRANSISTOR 2SA1163-G		R455	1-216-821-11	METAL CHIP 1K	5% 1/10W
Q535	8-729-216-31	TRANSISTOR 2SA1163-G		R456	1-216-821-11	METAL CHIP 1K	5% 1/10W
Q536	8-729-216-31	TRANSISTOR 2SA1163-G		R457	1-216-821-11	METAL CHIP 1K	5% 1/10W
Q540	8-729-620-07	TRANSISTOR 2SC3052EF-T1-LEF		R458	1-216-821-11	METAL CHIP 1K	5% 1/10W
Q560	8-729-620-07	TRANSISTOR 2SC3052EF-T1-LEF		R459	1-216-821-11	METAL CHIP 1K	5% 1/10W
Q571	8-729-119-76	TRANSISTOR 2SA1175-HFE		R468	1-216-845-11	METAL CHIP 100K	5% 1/10W
Q572	8-729-141-30	TRANSISTOR 2SC3623A-LK		R469	1-216-821-11	METAL CHIP 1K	5% 1/10W
Q580	8-729-620-07	TRANSISTOR 2SC3052EF-T1-LEF		R470	1-216-841-11	METAL CHIP 47K	5% 1/10W
Q601	8-729-119-76	TRANSISTOR 2SA1175-HFE		R471	1-216-841-11	METAL CHIP 47K	5% 1/10W (EXCEPT MX)
Q602	8-729-141-30	TRANSISTOR 2SC3623A-LK		R472	1-216-841-11	METAL CHIP 47K	5% 1/10W (EXCEPT MX)
Q605	8-729-216-31	TRANSISTOR 2SA1163-G		R473	1-216-841-11	METAL CHIP 47K	5% 1/10W
Q606	8-729-216-31	TRANSISTOR 2SA1163-G		R474	1-216-841-11	METAL CHIP 47K	5% 1/10W
Q610	8-729-620-07	TRANSISTOR 2SC3052EF-T1-LEF		R475	1-216-833-11	METAL CHIP 10K	5% 1/10W
Q612	8-729-620-07	TRANSISTOR 2SC3052EF-T1-LEF		R476	1-216-833-11	METAL CHIP 10K	5% 1/10W
Q640	8-729-620-07	TRANSISTOR 2SC3052EF-T1-LEF		R480	1-216-864-11	SHORT CHIP 0	
Q651	8-729-119-76	TRANSISTOR 2SA1175-HFE		R481	1-216-864-11	SHORT CHIP 0	
Q652	8-729-141-30	TRANSISTOR 2SC3623A-LK		R501	1-216-821-11	METAL CHIP 1K	5% 1/10W
Q655	8-729-216-31	TRANSISTOR 2SA1163-G		R502	1-216-843-11	METAL CHIP 68K	5% 1/10W
Q656	8-729-216-31	TRANSISTOR 2SA1163-G		R503	1-208-445-41	RES-CHIP 2.2K	2% 1/10W
Q680	8-729-620-07	TRANSISTOR 2SC3052EF-T1-LEF		R505	1-208-826-11	METAL CHIP 68K	0.5% 1/10W
Q691	8-729-281-53	TRANSISTOR 2SC1815-GR		R510	1-216-825-11	METAL CHIP 2.2K	5% 1/10W
Q692	8-729-029-40	TRANSISTOR DTA124ESA		R511	1-216-844-11	METAL CHIP 82K	5% 1/10W
Q701	8-729-119-76	TRANSISTOR 2SA1175-HFE		R513	1-216-818-11	METAL CHIP 560	5% 1/10W
Q702	8-729-141-30	TRANSISTOR 2SC3623A-LK		R514	1-249-399-11	CARBON 33	5% 1/4W F
Q705	8-729-216-31	TRANSISTOR 2SA1163-G		R515	1-249-399-11	CARBON 33	5% 1/4W F
Q706	8-729-216-31	TRANSISTOR 2SA1163-G		R516	1-234-182-11	ENCAPSULATED COMPONENT 0.22X2 5W	
Q710	8-729-620-07	TRANSISTOR 2SC3052EF-T1-LEF		R517	1-249-393-11	CARBON 10	5% 1/4W F
Q722	8-729-620-07	TRANSISTOR 2SC3052EF-T1-LEF		R518	1-249-389-11	CARBON 4.7	5% 1/4W F
Q723	8-729-620-07	TRANSISTOR 2SC3052EF-T1-LEF		R520	1-216-214-00	RES-CHIP 4.7K	2% 1/8W
Q725	8-729-216-31	TRANSISTOR 2SA1163-G		R521	1-240-855-11	CARBON 6.2K	5% 1/4W F
Q740	8-729-620-07	TRANSISTOR 2SC3052EF-T1-LEF		R522	1-216-823-11	METAL CHIP 1.5K	5% 1/10W
Q750	8-729-620-07	TRANSISTOR 2SC3052EF-T1-LEF		R523	1-216-841-11	METAL CHIP 47K	5% 1/10W
Q751	8-729-119-76	TRANSISTOR 2SA1175-HFE		R524	1-216-835-11	METAL CHIP 15K	5% 1/10W
Q752	8-729-141-30	TRANSISTOR 2SC3623A-LK		R525	1-216-843-11	METAL CHIP 68K	5% 1/10W
Q755	8-729-216-31	TRANSISTOR 2SA1163-G		R526	1-234-182-11	ENCAPSULATED COMPONENT 0.22X2 5W	
Q756	8-729-216-31	TRANSISTOR 2SA1163-G		R529	1-216-833-11	METAL CHIP 10K	5% 1/10W
Q790	8-729-620-07	TRANSISTOR 2SC3052EF-T1-LEF		R530	1-216-214-00	RES-CHIP 4.7K	2% 1/8W
Q793	8-729-620-07	TRANSISTOR 2SC3052EF-T1-LEF		R531	1-240-855-11	CARBON 6.2K	5% 1/4W F
				R532	1-216-833-11	METAL CHIP 10K	5% 1/10W

Ref. No.	Part No.	Description			Remark	Ref. No.	Part No.	Description			Remark
R533	1-216-841-11	METAL CHIP	47K	5%	1/10W	R657	1-216-835-11	METAL CHIP	15K	5%	1/10W
R534	1-216-835-11	METAL CHIP	15K	5%	1/10W	R660	1-216-825-11	METAL CHIP	2.2K	5%	1/10W
R535	1-216-843-11	METAL CHIP	68K	5%	1/10W	R661	1-216-844-11	METAL CHIP	82K	5%	1/10W
R537	1-249-393-11	CARBON	10	5%	1/4W F	R663	1-216-818-11	METAL CHIP	560	5%	1/10W
R539	1-216-845-11	METAL CHIP	100K	5%	1/10W	R664	1-249-399-11	CARBON	33	5%	1/4W F
R540	1-216-837-11	METAL CHIP	22K	5%	1/10W	R665	1-249-399-11	CARBON	33	5%	1/4W F
R546	1-216-835-11	METAL CHIP	15K	5%	1/10W	R666	1-234-182-11	ENCAPSULATED COMPONENT	0.22X2	5W	
R553	1-208-445-41	RES-CHIP	2.2K	2%	1/10W	R667	1-249-393-11	CARBON	10	5%	1/4W F
R554	1-208-826-11	METAL CHIP	68K	0.5%	1/10W	R668	1-249-389-11	CARBON	4.7	5%	1/4W F
R555	1-216-829-11	METAL CHIP	4.7K	5%	1/10W	R669	1-216-214-00	RES-CHIP	4.7K	2%	1/8W
R556	1-216-841-11	METAL CHIP	47K	5%	1/10W	R671	1-240-855-11	CARBON	6.2K	5%	1/4W F
R557	1-216-835-11	METAL CHIP	15K	5%	1/10W	R672	1-216-823-11	METAL CHIP	1.5K	5%	1/10W
R561	1-216-821-11	METAL CHIP	1K	5%	1/10W	R673	1-216-841-11	METAL CHIP	47K	5%	1/10W
R562	1-216-843-11	METAL CHIP	68K	5%	1/10W	R674	1-216-835-11	METAL CHIP	15K	5%	1/10W
R568	1-249-389-11	CARBON	4.7	5%	1/4W F	R675	1-216-829-11	METAL CHIP	4.7K	5%	1/10W
R570	1-208-445-41	RES-CHIP	2.2K	2%	1/10W	R676	1-216-841-11	METAL CHIP	47K	5%	1/10W
R571	1-216-844-11	METAL CHIP	82K	5%	1/10W	R677	1-216-835-11	METAL CHIP	15K	5%	1/10W
R572	1-216-823-11	METAL CHIP	1.5K	5%	1/10W	R680	1-216-837-11	METAL CHIP	22K	5%	1/10W
R573	1-216-841-11	METAL CHIP	47K	5%	1/10W	R681	1-216-835-11	METAL CHIP	15K	5%	1/10W
R574	1-249-399-11	CARBON	33	5%	1/4W F	R690	1-216-849-11	METAL CHIP	220K	5%	1/10W
R575	1-249-399-11	CARBON	33	5%	1/4W F	△ R691	1-215-886-11	METAL OXIDE	100	5%	2W F
R576	1-216-818-11	METAL CHIP	560	5%	1/10W	△ R692	1-215-889-00	METAL OXIDE	330	5%	2W F
R580	1-216-837-11	METAL CHIP	22K	5%	1/10W	R693	1-216-833-11	METAL CHIP	10K	5%	1/10W
R585	1-216-829-11	METAL CHIP	4.7K	5%	1/10W	R694	1-216-833-11	METAL CHIP	10K	5%	1/10W
R586	1-216-841-11	METAL CHIP	47K	5%	1/10W	R695	1-216-833-11	METAL CHIP	10K	5%	1/10W
R587	1-216-835-11	METAL CHIP	15K	5%	1/10W	R696	1-216-841-11	METAL CHIP	47K	5%	1/10W
R588	1-216-835-11	METAL CHIP	15K	5%	1/10W	R698	1-216-833-11	METAL CHIP	10K	5%	1/10W
R601	1-216-821-11	METAL CHIP	1K	5%	1/10W	R699	1-216-853-11	METAL CHIP	470K	5%	1/10W
R602	1-216-843-11	METAL CHIP	68K	5%	1/10W	R701	1-216-821-11	METAL CHIP	1K	5%	1/10W
R603	1-208-445-41	RES-CHIP	2.2K	2%	1/10W	R702	1-216-843-11	METAL CHIP	68K	5%	1/10W
R604	1-208-826-11	METAL CHIP	68K	0.5%	1/10W	R703	1-208-445-41	RES-CHIP	2.2K	2%	1/10W
R610	1-216-825-11	METAL CHIP	2.2K	5%	1/10W	R704	1-208-826-11	METAL CHIP	68K	0.5%	1/10W
R611	1-216-844-11	METAL CHIP	82K	5%	1/10W	R710	1-216-825-11	METAL CHIP	2.2K	5%	1/10W
R613	1-216-818-11	METAL CHIP	560	5%	1/10W	R711	1-216-844-11	METAL CHIP	82K	5%	1/10W
R614	1-249-399-11	CARBON	33	5%	1/4W F	R713	1-216-818-11	METAL CHIP	560	5%	1/10W
R615	1-249-399-11	CARBON	33	5%	1/4W F	R714	1-249-399-11	CARBON	33	5%	1/4W F
R616	1-234-182-11	ENCAPSULATED COMPONENT	0.22X2	5W		R715	1-249-399-11	CARBON	33	5%	1/4W F
R617	1-249-393-11	CARBON	10	5%	1/4W F	R716	1-234-182-11	ENCAPSULATED COMPONENT	0.22X2	5W	
R618	1-249-389-11	CARBON	4.7	5%	1/4W F	R717	1-249-393-11	CARBON	10	5%	1/4W F
R620	1-216-214-00	RES-CHIP	4.7K	2%	1/8W	R718	1-249-389-11	CARBON	4.7	5%	1/4W F
R621	1-240-855-11	CARBON	6.2K	5%	1/4W F	R719	1-216-214-00	RES-CHIP	4.7K	2%	1/8W
R622	1-216-823-11	METAL CHIP	1.5K	5%	1/10W	R721	1-240-855-11	CARBON	6.2K	5%	1/4W F
R623	1-216-841-11	METAL CHIP	47K	5%	1/10W	R722	1-216-823-11	METAL CHIP	1.5K	5%	1/10W
R624	1-216-835-11	METAL CHIP	15K	5%	1/10W	R723	1-216-841-11	METAL CHIP	47K	5%	1/10W
R625	1-216-843-11	METAL CHIP	68K	5%	1/10W	R724	1-216-835-11	METAL CHIP	15K	5%	1/10W
R631	1-216-821-11	METAL CHIP	1K	5%	1/10W	R725	1-216-843-11	METAL CHIP	68K	5%	1/10W
R633	1-216-821-11	METAL CHIP	1K	5%	1/10W	R729	1-216-833-11	METAL CHIP	10K	5%	1/10W
R634	1-249-404-00	CARBON	82	5%	1/4W F	R731	1-216-825-11	METAL CHIP	2.2K	5%	1/10W
R635	1-249-404-00	CARBON	82	5%	1/4W F	R732	1-249-381-11	CARBON	1	5%	1/4W F
R638	1-216-843-11	METAL CHIP	68K	5%	1/10W	R733	1-249-381-11	CARBON	1	5%	1/4W F
R640	1-216-837-11	METAL CHIP	22K	5%	1/10W	R734	1-249-404-00	CARBON	82	5%	1/4W F
R648	1-216-835-11	METAL CHIP	15K	5%	1/10W	R735	1-218-867-11	METAL CHIP	6.8K	0.5%	1/10W
R651	1-216-821-11	METAL CHIP	1K	5%	1/10W	R736	1-216-821-11	METAL CHIP	1K	5%	1/10W
R652	1-216-843-11	METAL CHIP	68K	5%	1/10W	R737	1-216-840-11	METAL CHIP	39K	5%	1/10W
R653	1-208-445-41	RES-CHIP	2.2K	2%	1/10W	R739	1-216-845-11	METAL CHIP	100K	5%	1/10W
R654	1-208-826-11	METAL CHIP	68K	0.5%	1/10W	R740	1-216-837-11	METAL CHIP	22K	5%	1/10W
R655	1-216-829-11	METAL CHIP	4.7K	5%	1/10W	R741	1-216-230-00	RES-CHIP	22K	2%	1/8W
R656	1-216-841-11	METAL CHIP	47K	5%	1/10W	R743	1-216-230-00	RES-CHIP	22K	2%	1/8W

# STR-K1600

Ver. 1.1

**MAIN**   **POWER KEY**

Ref. No.	Part No.	Description			Remark	Ref. No.	Part No.	Description			Remark
R744	1-216-230-00	RES-CHIP	22K	2%	1/8W	R3013	1-216-841-11	METAL CHIP	47K	5%	1/10W (AUS,MY,SP,TH)
R745	1-216-829-11	METAL CHIP	4.7K	5%	1/10W	R3020	1-216-841-11	METAL CHIP	47K	5%	1/10W (AUS,MY,SP,TH)
R746	1-216-841-11	METAL CHIP	47K	5%	1/10W	R3021	1-218-887-11	METAL CHIP	47K	0.5%	1/10W (AUS,MY,SP,TH)
R747	1-216-835-11	METAL CHIP	15K	5%	1/10W	R3022	1-218-887-11	METAL CHIP	47K	0.5%	1/10W (AUS,MY,SP,TH)
R748	1-216-835-11	METAL CHIP	15K	5%	1/10W	R3023	1-216-841-11	METAL CHIP	47K	5%	1/10W (AUS,MY,SP,TH)
R749	1-216-833-11	METAL CHIP	10K	5%	1/10W	RR11	1-249-393-11	CARBON	10	5%	1/4W F (AUS)
R750	1-216-837-11	METAL CHIP	22K	5%	1/10W	RR12	1-249-393-11	CARBON	10	5%	1/4W F (AUS)
R751	1-216-821-11	METAL CHIP	1K	5%	1/10W	RR13	1-249-393-11	CARBON	10	5%	1/4W F (AUS)
R752	1-216-843-11	METAL CHIP	68K	5%	1/10W	RR14	1-249-393-11	CARBON	10	5%	1/4W F (AUS)
R753	1-208-445-41	RES-CHIP	2.2K	2%	1/10W	RR15	1-249-393-11	CARBON	10	5%	1/4W F (AUS)
R754	1-208-826-11	METAL CHIP	68K	0.5%	1/10W	RR16	1-249-393-11	CARBON	10	5%	1/4W F (AUS)
R755	1-216-829-11	METAL CHIP	4.7K	5%	1/10W	RR17	1-249-393-11	CARBON	10	5%	1/4W F (AUS)
R756	1-216-841-11	METAL CHIP	47K	5%	1/10W	RR18	1-249-393-11	CARBON	10	5%	1/4W F (AUS)
R757	1-216-835-11	METAL CHIP	15K	5%	1/10W	< RELAY >					
R758	1-216-835-11	METAL CHIP	15K	5%	1/10W	RY560	1-755-267-11	RELAY			
R759	1-216-845-11	METAL CHIP	100K	5%	1/10W	RY601	1-755-170-11	RELAY (12V)			
R760	1-216-825-11	METAL CHIP	2.2K	5%	1/10W	RY610	1-755-170-11	RELAY (12V)			
R761	1-216-844-11	METAL CHIP	82K	5%	1/10W	RY701	1-755-170-11	RELAY (12V)			
R763	1-216-818-11	METAL CHIP	560	5%	1/10W	RY791	1-755-170-11	RELAY (12V)			
R764	1-249-399-11	CARBON	33	5%	1/4W F	< TERMINAL BOARD >					
R765	1-249-399-11	CARBON	33	5%	1/4W F	TB001	1-780-449-11	BANANA-PUSH TERMINAL BOARD (8P) (SPEAKERS FRONT,SURROUND)			
R766	1-234-182-11	ENCAPSULATED COMPONENT	0.22X2 5W			TM603	1-780-451-11	BANANA-PUSH TERMINAL BOARD (4P) (SPEAKERS CENTER,SURROUND BACK)			
R767	1-249-393-11	CARBON	10	5%	1/4W F	*****					
R768	1-249-389-11	CARBON	4.7	5%	1/4W F	POWER KEY BOARD					
R769	1-216-214-00	RES-CHIP	4.7K	2%	1/8W	*****					
R770	1-216-845-11	METAL CHIP	100K	5%	1/10W	< CONNECTOR >					
R771	1-240-855-11	CARBON	6.2K	5%	1/4W F	* CN103	1-691-670-11	CONNECTOR, BOARD TO BOARD 5P			
R772	1-216-823-11	METAL CHIP	1.5K	5%	1/10W	< RESISTOR >					
R773	1-216-841-11	METAL CHIP	47K	5%	1/10W	R111	1-249-415-11	CARBON	680	5%	1/4W
R775	1-216-843-11	METAL CHIP	68K	5%	1/10W	R112	1-247-831-11	CARBON	1K	5%	1/4W
R778	1-216-835-11	METAL CHIP	15K	5%	1/10W	< ROTARY ENCODER >					
R780	1-216-833-11	METAL CHIP	10K	5%	1/10W	RV103	1-418-817-11	ENCODER, ROTARY (- TUNING +)			
R790	1-216-845-11	METAL CHIP	100K	5%	1/10W	< SWITCH >					
R791	1-216-825-11	METAL CHIP	2.2K	5%	1/10W	S100	1-771-410-21	SWITCH, TACTILE (I/C)			
△R792	1-215-868-00	METAL OXIDE	680	5%	1W F	S113	1-771-410-21	SWITCH, TACTILE (TUNING MODE)			
R793	1-249-404-00	CARBON	82	5%	1/4W F	S115	1-771-410-21	SWITCH, TACTILE (AUTO CAL)			
△R794	1-215-868-00	METAL OXIDE	680	5%	1W F	*****					
R802	1-249-409-11	CARBON	220	5%	1/4W F	*****					
R803	1-249-389-11	CARBON	4.7	5%	1/4W F	*****					
R804	1-216-833-11	METAL CHIP	10K	5%	1/10W	*****					
R806	1-216-837-11	METAL CHIP	22K	5%	1/10W	*****					
R840	1-218-867-11	METAL CHIP	6.8K	0.5%	1/10W	*****					
R843	1-216-864-11	SHORT CHIP	0			*****					
R844	1-216-837-11	METAL CHIP	22K	5%	1/10W	*****					
△R910	1-240-877-11	FUSIBLE	0.15	5%	1/2W F	*****					
R3001	1-216-837-11	METAL CHIP	22K	5%	1/10W	*****					
R3002	1-216-837-11	METAL CHIP	22K	5%	1/10W	*****					
R3003	1-216-835-11	METAL CHIP	15K	5%	1/10W	*****					
R3005	1-216-825-11	METAL CHIP	2.2K	5%	1/10W	*****					
R3006	1-216-833-11	METAL CHIP	10K	5%	1/10W	*****					
R3007	1-216-818-11	METAL CHIP	560	5%	1/10W	*****					
R3008	1-249-393-11	CARBON	10	5%	1/4W F	*****					
R3010	1-216-841-11	METAL CHIP	47K	5%	1/10W (AUS,MY,SP,TH)	*****					
R3011	1-218-887-11	METAL CHIP	47K	0.5%	1/10W (AUS,MY,SP,TH)	*****					
R3012	1-218-887-11	METAL CHIP	47K	0.5%	1/10W (AUS,MY,SP,TH)	*****					



Ref. No.	Part No.	Description	Remark	Ref. No.	Part No.	Description	Remark
		STANDBY BOARD *****		△ T902	1-443-518-11	TRANSFORMER, POWER (SUB) (MX)	
				△ T902	1-443-520-11	TRANSFORMER, POWER (SUB) (E51)	
				*****			
		1-533-217-41 HOLDER, FUSE				VIDEO BOARD *****	
		< CAPACITOR >				< CAPACITOR >	
C913	1-127-888-11	CERAMIC	0.1uF 10% 50V	C206	1-126-964-11	ELECT	10uF 20% 50V
C914	1-127-888-11	CERAMIC	0.1uF 10% 50V	C207	1-126-964-11	ELECT	10uF 20% 50V
C915	1-126-943-11	ELECT	2200uF 20% 25V	C208	1-126-964-11	ELECT	10uF 20% 50V
C916	1-126-942-61	ELECT	1000uF 20% 25V	C209	1-126-964-11	ELECT	10uF 20% 50V
C920	1-127-888-11	CERAMIC	0.1uF 10% 50V	C210	1-126-947-11	ELECT	47uF 20% 35V
C921	1-127-888-11	CERAMIC	0.1uF 10% 50V	C213	1-126-947-11	ELECT	47uF 20% 35V
C924	1-126-960-11	ELECT	1uF 20% 50V	C214	1-127-888-11	CERAMIC	0.1uF 10% 50V
C950	1-126-936-11	ELECT	3300uF 20% 16V	C215	1-127-888-11	CERAMIC	0.1uF 10% 50V
		< CONNECTOR >		C220	1-126-947-11	ELECT	47uF 20% 35V
CNP002	1-568-106-11	PIN, CONNECTOR (3.96mm PITCH) 4P (E51)		C221	1-126-947-11	ELECT	47uF 20% 35V
* CNP802	1-564-509-11	PLUG, CONNECTOR 6P		C223	1-135-799-11	CERAMIC	0.47uF 50V
* CNP804	1-564-506-11	PLUG, CONNECTOR 3P		C224	1-135-799-11	CERAMIC	0.47uF 50V
* CNP805	1-564-506-11	PLUG, CONNECTOR 3P (AUS,MY,SP,TH)		C308	1-126-964-11	ELECT	10uF 20% 50V
CNP901	1-564-321-00	PIN, CONNECTOR (3.96mm PITCH) 2P		C309	1-126-964-11	ELECT	10uF 20% 50V
* CNP902	1-565-792-11	PIN, CONNECTOR (3.96mm PITCH) 2P		C310	1-126-964-11	ELECT	10uF 20% 50V
* CNP903	1-564-508-11	PLUG, CONNECTOR 5P		C311	1-126-964-11	ELECT	10uF 20% 50V
		< DIODE >		C312	1-126-964-11	ELECT	10uF 20% 50V
D901	8-719-991-33	DIODE 1SS133T-77		C313	1-126-964-11	ELECT	10uF 20% 50V
D910	6-500-522-11	DIODE 10EDB40-TA2B5		C314	1-126-964-11	ELECT	10uF 20% 50V
D911	6-500-522-11	DIODE 10EDB40-TA2B5		C315	1-126-964-11	ELECT	10uF 20% 50V
D912	6-500-522-11	DIODE 10EDB40-TA2B5		C316	1-126-964-11	ELECT	10uF 20% 50V
D913	6-500-522-11	DIODE 10EDB40-TA2B5		C330	1-127-888-11	CERAMIC	0.1uF 10% 50V
D914	8-719-991-33	DIODE 1SS133T-77		C331	1-127-888-11	CERAMIC	0.1uF 10% 50V
D915	8-719-991-33	DIODE 1SS133T-77		C337	1-126-947-11	ELECT	47uF 20% 35V
D920	6-500-522-11	DIODE 10EDB40-TA2B5		C338	1-126-947-11	ELECT	47uF 20% 35V
D921	6-500-522-11	DIODE 10EDB40-TA2B5		C340	1-127-888-11	CERAMIC	0.1uF 10% 50V
D922	6-500-522-11	DIODE 10EDB40-TA2B5				< CONNECTOR >	
D923	6-500-522-11	DIODE 10EDB40-TA2B5		CNP202	1-564-705-11	PIN, CONNECTOR (SMALL TYPE) 3P	
		< TRANSISTOR >		* CNP203	1-564-507-11	PLUG, CONNECTOR 4P	
Q901	8-729-119-78	TRANSISTOR 2SC2785-HFE		CNS207	1-784-774-11	CONNECTOR, FFC 13P	
Q921	8-729-119-78	TRANSISTOR 2SC2785-HFE				< DIODE >	
		< RESISTOR >		D203	8-719-991-33	DIODE 1SS133T-77	
△ R810	1-243-634-91	FUSIBLE	0.22 5% 1/2W F	D204	8-719-991-33	DIODE 1SS133T-77	
△ R811	1-243-634-91	FUSIBLE	0.22 5% 1/2W F			< IC >	
R902	1-247-871-11	CARBON	47K 5% 1/4W	IC203	6-701-890-01	IC NJM2595D	
R903	1-249-421-11	CARBON	2.2K 5% 1/4W	IC304	6-707-363-01	IC NJM2586AL	
R904	1-249-381-11	CARBON	1 5% 1/4W F	IC804	8-759-245-79	IC TA79005S	
R921	1-247-871-11	CARBON	47K 5% 1/4W	IC807	8-759-231-53	IC TA7805S	
R922	1-247-863-11	CARBON	22K 5% 1/4W			< JACK >	
R923	1-249-429-11	CARBON	10K 5% 1/4W	J200	1-794-978-11	JACK, PIN 3P (SAT VIDEO IN, DVD VIDEO IN,VIDEO 1 VIDEO OUT)	
		< RELAY >		J201	1-815-043-11	JACK, PIN 2P (VIDEO 1 VIDEO IN, MONITOR VIDEO OUT)	
△ RY901	1-755-541-11	RELAY		J301	1-816-592-11	JACK, PIN 9P (COMPONENT VIDEO SAT IN,DVD IN,VIDEO 1 IN)	
		< TRANSFORMER >		J302	1-815-360-11	JACK, PIN 3P (COMPONENT VIDEO MONITOR OUT)	
△ T902	1-443-517-11	TRANSFORMER, POWER (SUB) (EXCEPT E51,MX)					

# STR-K1600

Ver. 1.1

VIDEO VIDEO 3

Ref. No.	Part No.	Description	Remark	Ref. No.	Part No.	Description	Remark
< RESISTOR >				MISCELLANEOUS *****			
R200	1-247-804-11	CARBON	75 5% 1/4W	57	1-829-004-51	WIRE (FLAT TYPE) (19 CORE)	
R201	1-247-804-11	CARBON	75 5% 1/4W	101	1-829-953-11	WIRE (FLAT TYPE) (9 CORE)	
R218	1-247-804-11	CARBON	75 5% 1/4W	102	1-828-973-11	WIRE (FLAT TYPE) (13 CORE)	
R219	1-247-804-11	CARBON	75 5% 1/4W	△105	1-696-848-81	CORD, POWER (AUS)	
R220	1-247-804-11	CARBON	75 5% 1/4W	△105	1-777-071-83	CORD, POWER (E51,MY,SP,TH)	
R221	1-247-804-11	CARBON	75 5% 1/4W	△105	1-783-941-12	CORD, POWER (AR)	
R301	1-247-804-11	CARBON	75 5% 1/4W	△105	1-829-627-11	POWER-SUPPLY CORD (MX)	
R302	1-247-804-11	CARBON	75 5% 1/4W	△107	1-569-008-22	ADAPTOR, CONVERSION 2P (E51)	
R303	1-247-804-11	CARBON	75 5% 1/4W	△F901	1-532-464-33	FUSE (T2.5AL/250V) (EXCEPT MX)	
R304	1-247-804-11	CARBON	75 5% 1/4W	△F901	1-532-504-33	FUSE (T4AL/250V) (MX)	
R305	1-247-804-11	CARBON	75 5% 1/4W	△F4001	1-532-465-33	FUSE (T3.15AL/250V) (AUS,MY,SP,TH)	
R306	1-247-804-11	CARBON	75 5% 1/4W	△F4002	1-532-465-33	FUSE (T3.15AL/250V) (AUS,MY,SP,TH)	
R307	1-247-804-11	CARBON	75 5% 1/4W	Q503	6-702-390-01	TRANSISTOR MN2488-OPY-MK	
R308	1-247-804-11	CARBON	75 5% 1/4W	Q504	6-702-391-01	TRANSISTOR MP1620-OPY-MK	
R309	1-247-804-11	CARBON	75 5% 1/4W	Q533	6-702-390-01	TRANSISTOR MN2488-OPY-MK	
R310	1-247-804-11	CARBON	75 5% 1/4W	Q534	6-702-391-01	TRANSISTOR MP1620-OPY-MK	
R311	1-247-804-11	CARBON	75 5% 1/4W	Q603	6-702-390-01	TRANSISTOR MN2488-OPY-MK	
R312	1-247-804-11	CARBON	75 5% 1/4W	Q604	6-702-391-01	TRANSISTOR MP1620-OPY-MK	
*****				Q653	6-702-390-01	TRANSISTOR MN2488-OPY-MK	
VIDEO 3 BOARD				Q654	6-702-391-01	TRANSISTOR MP1620-OPY-MK	
*****				Q703	6-702-390-01	TRANSISTOR MN2488-OPY-MK	
< CAPACITOR >				Q704	6-702-391-01	TRANSISTOR MP1620-OPY-MK	
C293	1-100-566-11	CERAMIC CHIP	0.1uF 10% 25V	Q753	6-702-390-01	TRANSISTOR MN2488-OPY-MK	
C294	1-100-566-11	CERAMIC CHIP	0.1uF 10% 25V	Q754	6-702-391-01	TRANSISTOR MP1620-OPY-MK	
C298	1-162-960-11	CERAMIC CHIP	220PF 10% 50V	△T901	1-443-523-11	TRANSFORMER, POWER (MAIN) (MX)	
C299	1-162-960-11	CERAMIC CHIP	220PF 10% 50V	△T901	1-443-525-11	TRANSFORMER, POWER (MAIN) (EXCEPT E51,MX)	
< CONNECTOR >				△T901	1-443-526-11	TRANSFORMER, POWER (MAIN) (E51)	
CN201	1-564-721-11	PIN, CONNECTOR (SMALL TYPE) 5P		TN1	1-693-728-11	TUNER (FM/AM) (ANTENNA) (MX)	
* CN202	1-690-880-31	LEAD (WITH CONNECTOR)		TN1	1-693-733-11	TUNER (FM/AM) (ANTENNA) (E51,AR)	
< JACK >				TN1	1-693-735-11	TUNER (FM/AM) (ANTENNA) (AUS,MY,SP,TH)	
J298	1-819-187-11	JACK, PIN 3P (VIDEO 3 IN/PORTABLE AV IN VIDEO,AUDIO)					
< RESISTOR >							
R298	1-216-821-11	METAL CHIP	1K 5% 1/10W				
R299	1-216-821-11	METAL CHIP	1K 5% 1/10W				
*****							

MEMO

