

665F

TA-636

30475

US Model
 Canadian Model
 AEP Model
 E Model
 UK Model



(Slits in the case of some sets differ
 from those in this photograph.)

INTEGRATED STEREO AMPLIFIER

SPECIFICATIONS

GENERAL

SAFETY-RELATED COMPONENT WARNING!!

COMPONENTS IDENTIFIED BY SHADING AND MARK  ON THE SCHEMATIC DIAGRAMS, EXPLODED VIEWS AND IN THE PARTS LIST ARE CRITICAL TO SAFE OPERATION. REPLACE THESE COMPONENTS WITH SONY PARTS WHOSE PART NUMBERS APPEAR AS SHOWN IN THIS MANUAL OR IN SUPPLEMENTS PUBLISHED BY SONY.

ATTENTION AU COMPOSANT AYANT RAPPORT À LA SÉCURITÉ!

LES COMPOSANTS IDENTIFIÉS PAR UNE TRAME ET UNE MARQUE  SUR LES DIAGRAMMES SCHEMATIQUES, LES VUES EXPLOSÉES ET LA LISTE DES PIÈCES SONT CRITIQUES POUR LA SÉCURITÉ DE FONCTIONNEMENT. NE REMPLACER CES COMPOSANTS QUE PAR DES PIÈCES SONY DONT LES NUMÉROS SONT DONNÉS DANS CE MANUEL OU DANS LES SUPPLÉMENTS PUBLIÉS PAR SONY.

Power Requirements:	120V ac, 60 Hz (US, Canadian model) 220V ac, 50 Hz (AEP model) 240V ac, 50 Hz (UK model) 120, 220, or 240V ac adjustable, 50/60 Hz (E model)
Power Consumption:	190W (US, Canadian model) 380W (AEP, E model) 480W (UK model)
AC Outlets:	1 switched (100W), 2 unswitched (total 200W)
Dimensions:	Approx. 430 (w) x 135 (h) x 300 (d) mm 17 (w) x 5 1/4 (h) x 11 7/8 (d) inches including projecting parts and controls
Weight:	Approx. 8.8 kg, 19 lb 7 oz (net) Approx. 10 kg, 22 lb 1 oz (in shipping carton)

— Continued on page 2 —

SONY[®]
SERVICE MANUAL

1155

1-2. BLOCK DIAGRAM

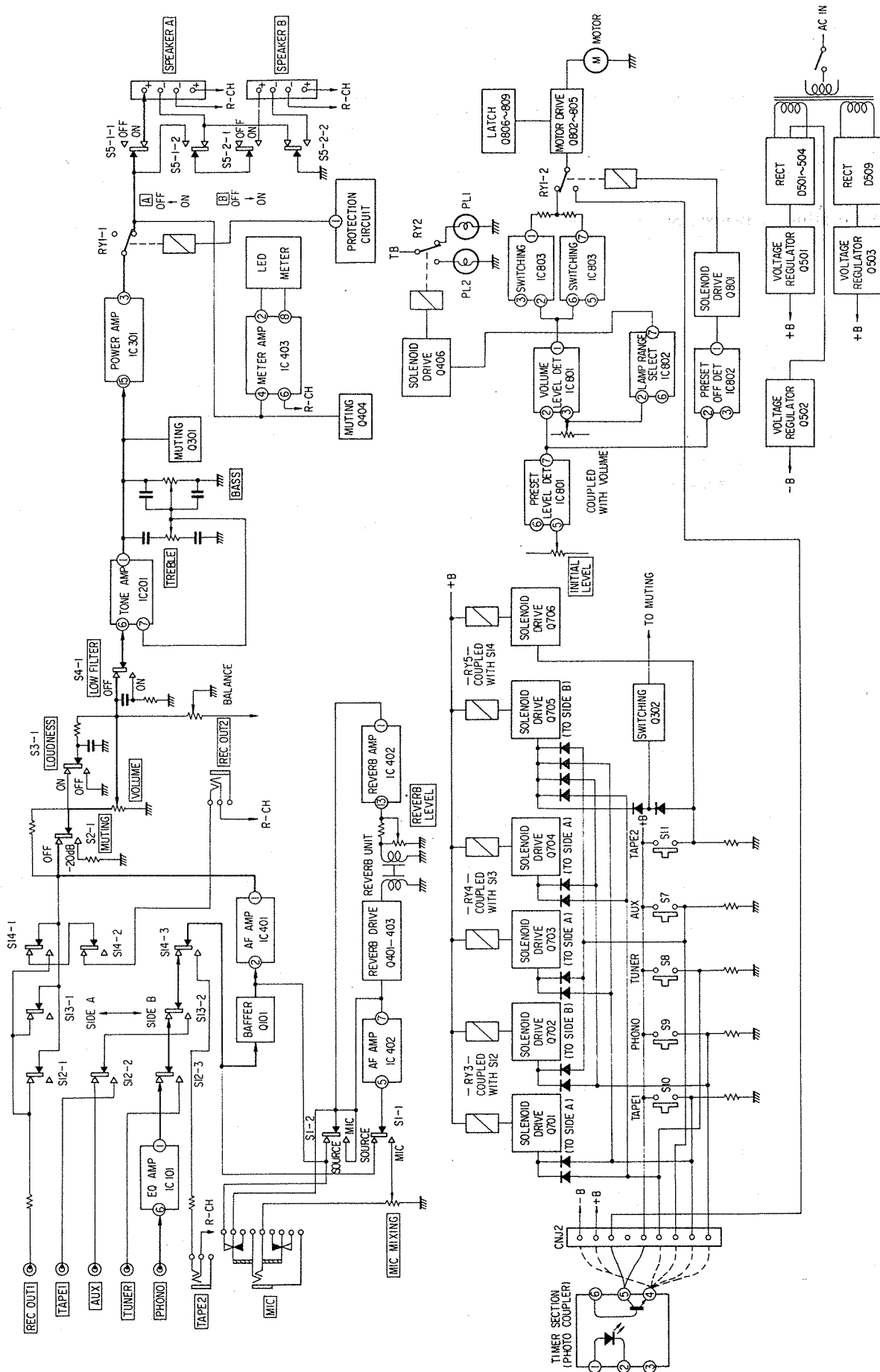

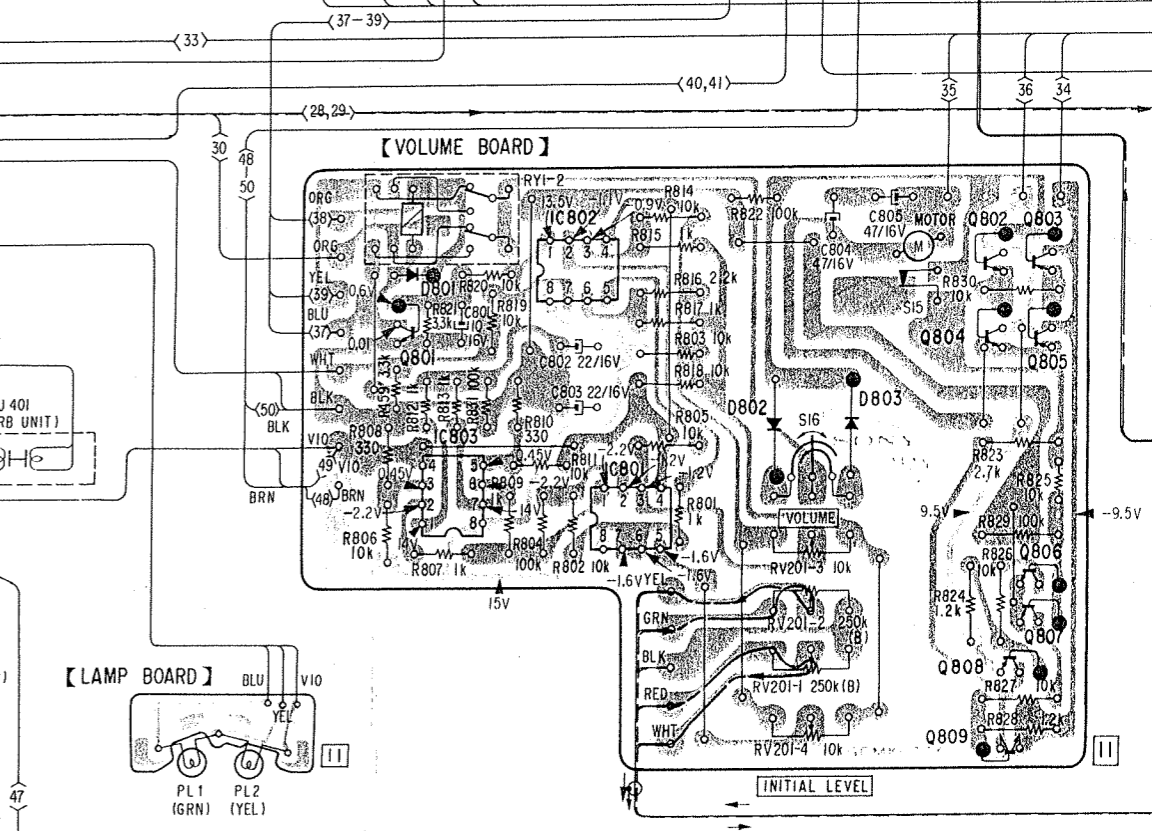
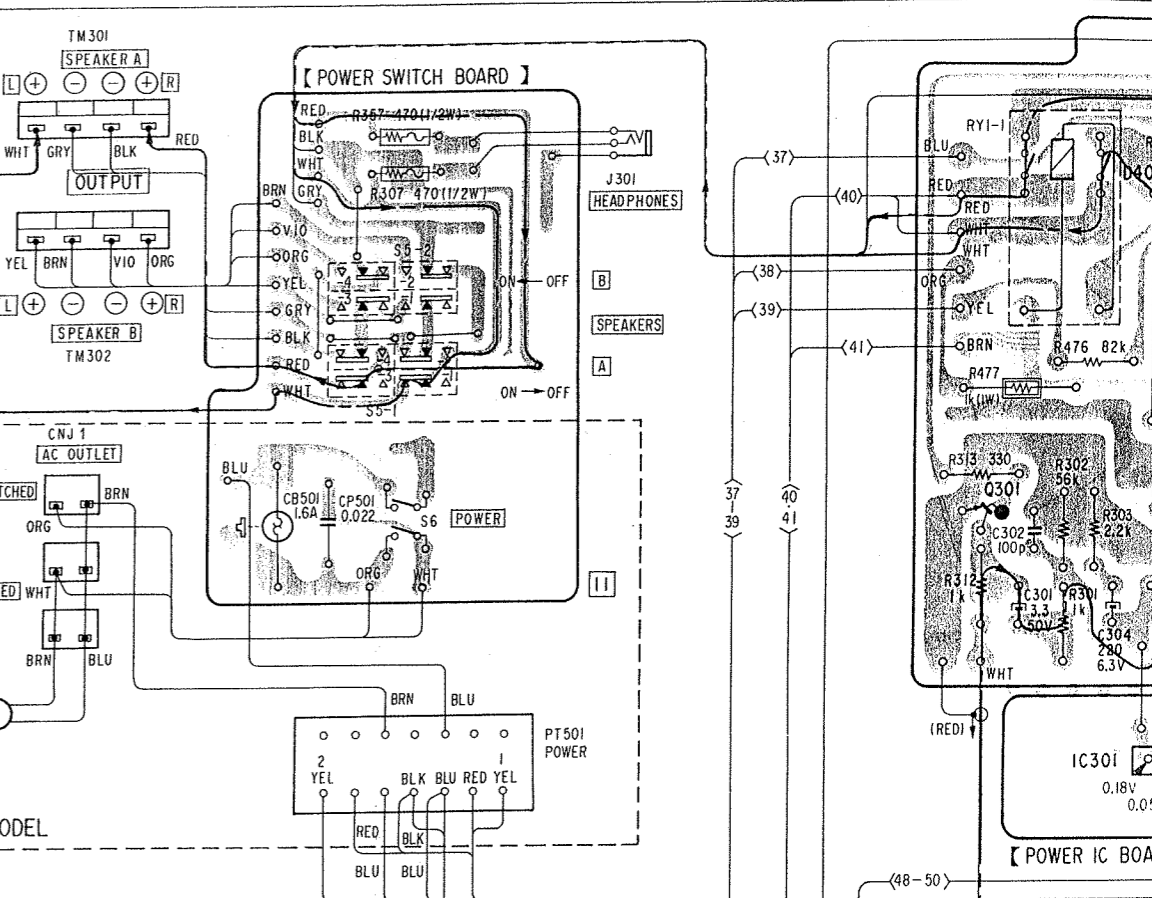
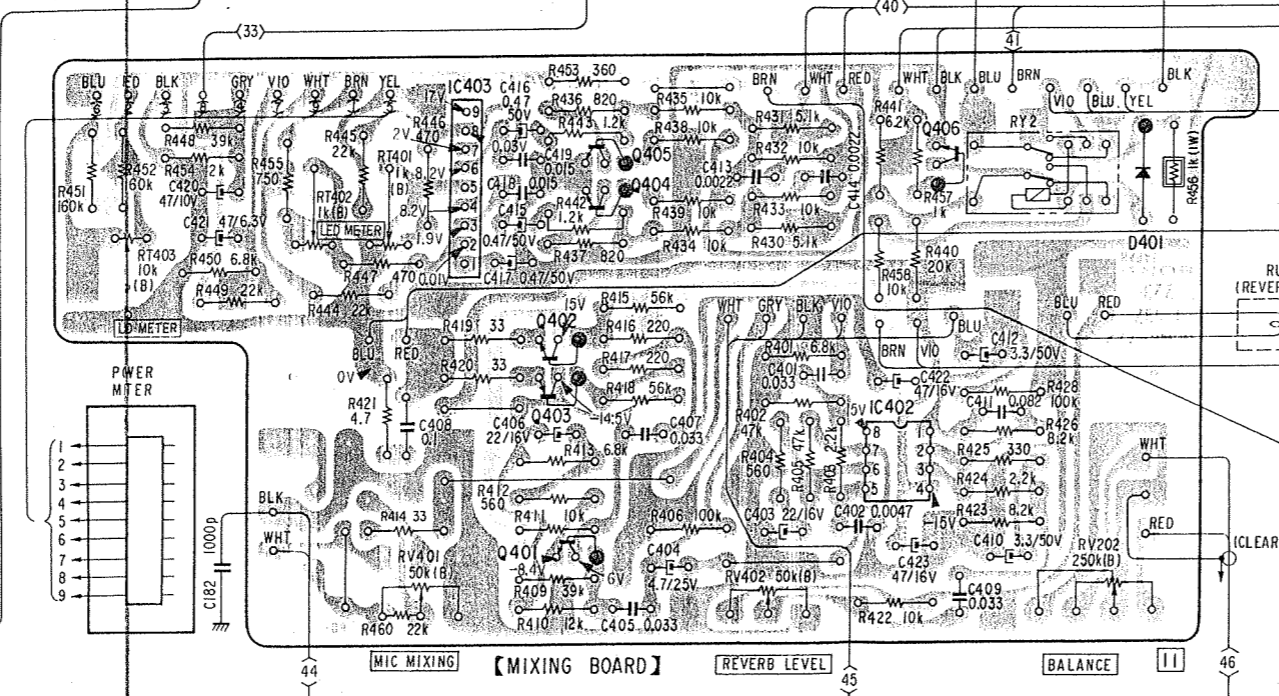
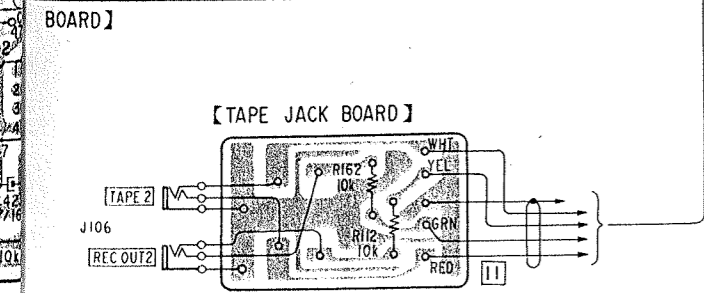
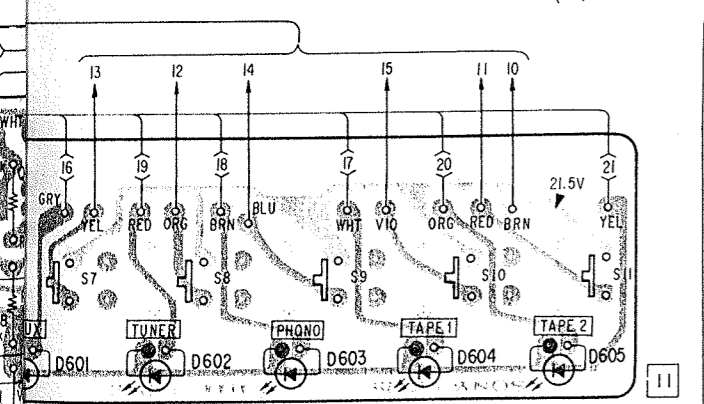
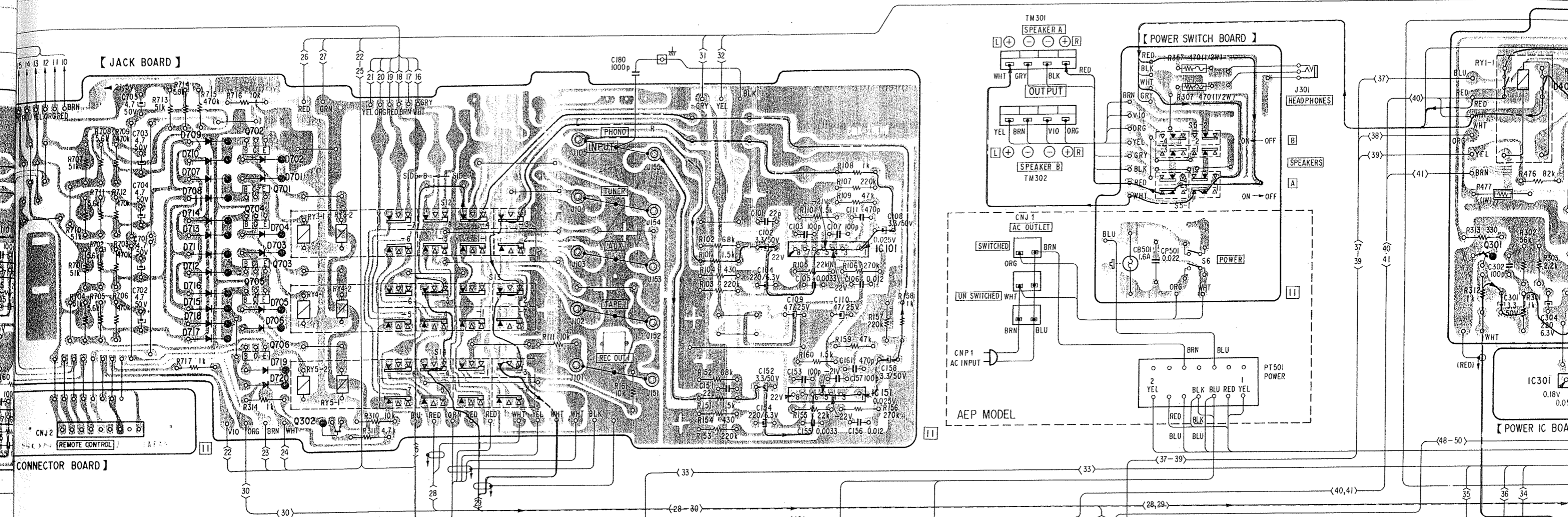

701	706	302	IC403	402	403	404	405	406	IC101	IC151	801	IC803	IC802	IC801	301	802	808	803	806	805	807	402
602	603	707	701	719	706	720	605				801				802	803						
		718																				

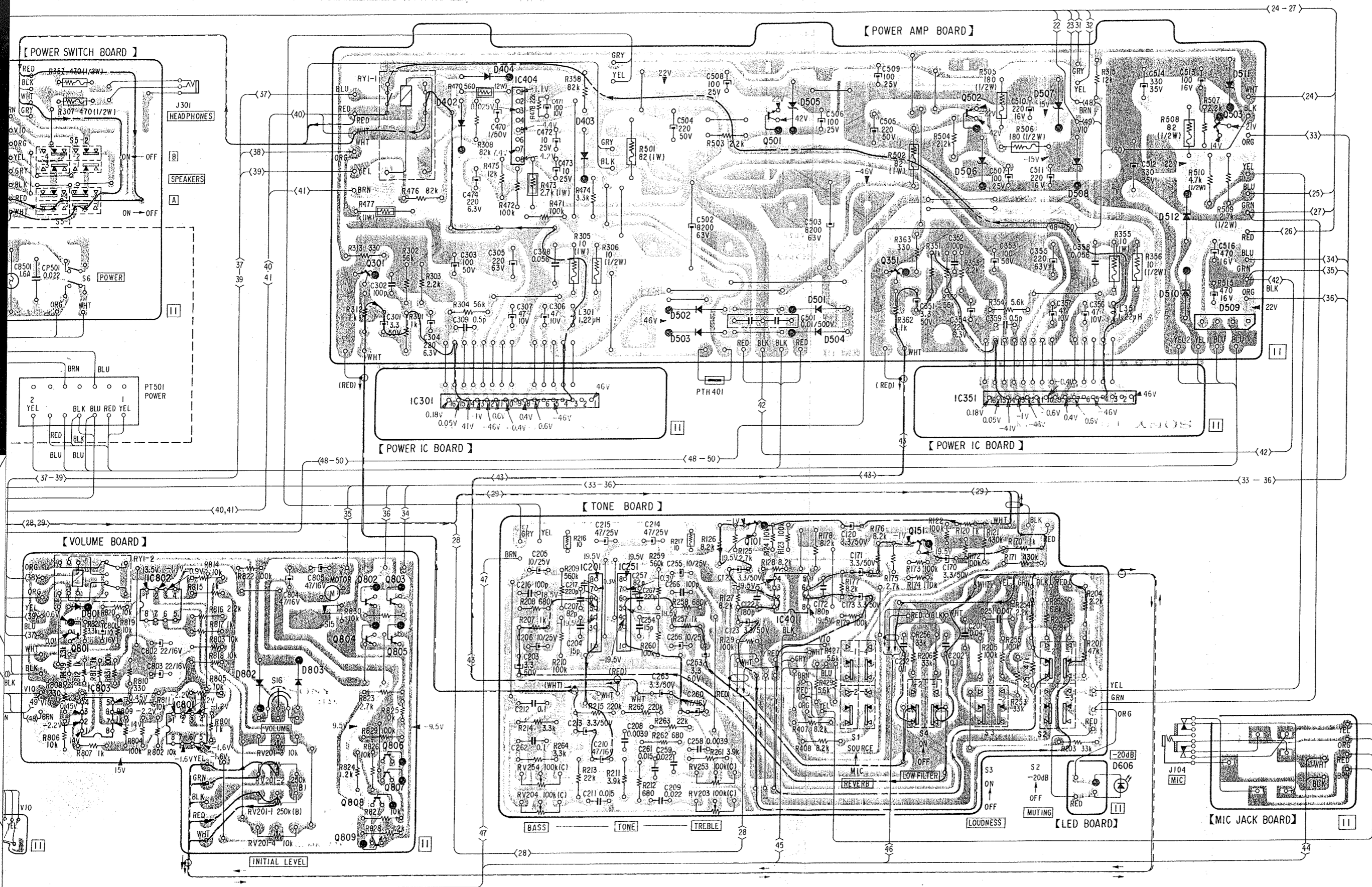

801	IC803	IC802	IC801	301	802	808	803	805	806	IC404	IC301	IC201	IC251	501	101	IC401	351	151	502	IC351	503	Q		
801				804	809	807								502	503	505	501	504	506	507	508	512	511	D
																					606	510	509	

4-2. SCHEMATIC DIAGRAM

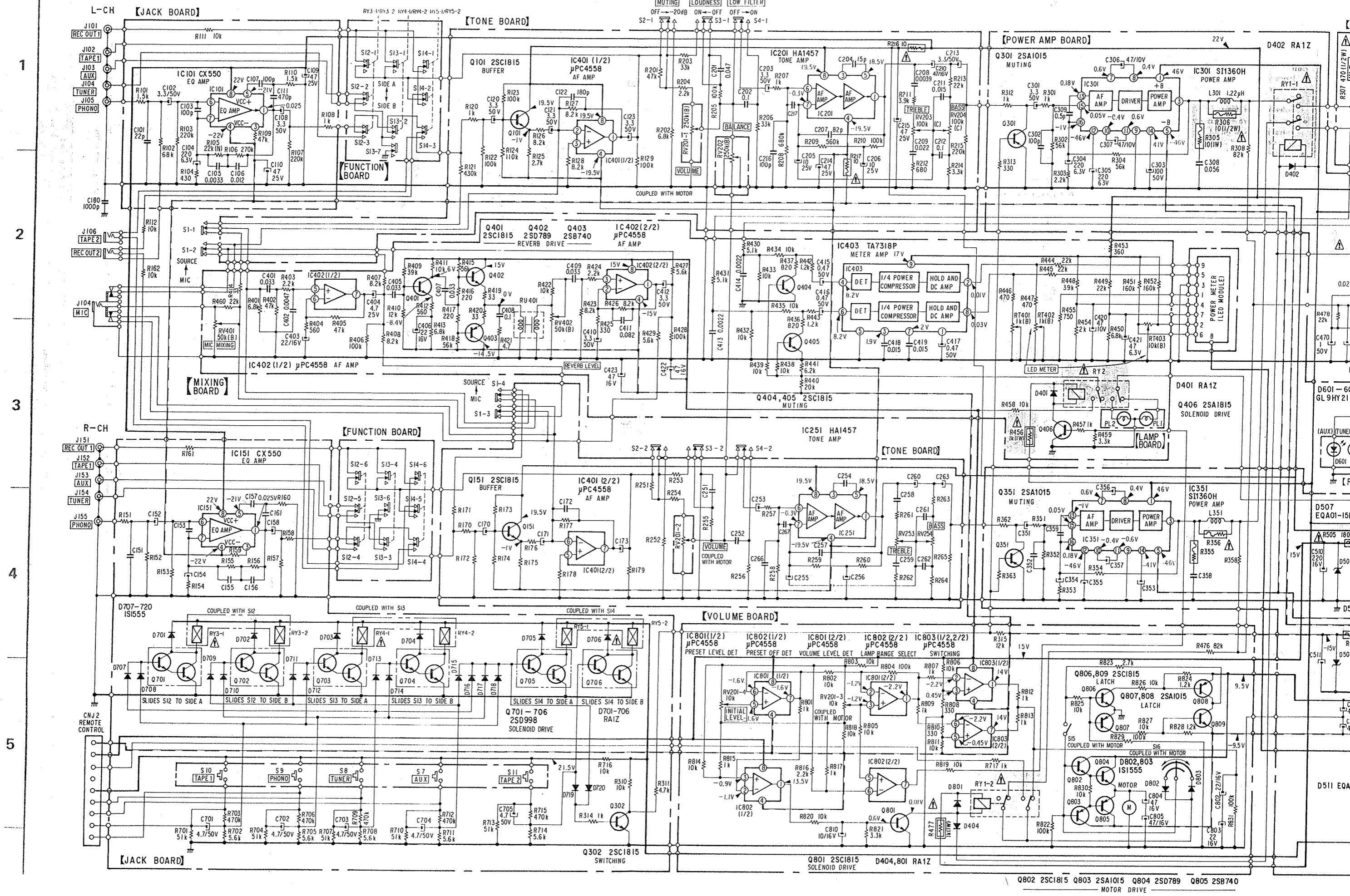

Q802 2SC1815 Q803 2SA1015 Q804 2SD789 Q805 2SB740
MOTOR DRIVE

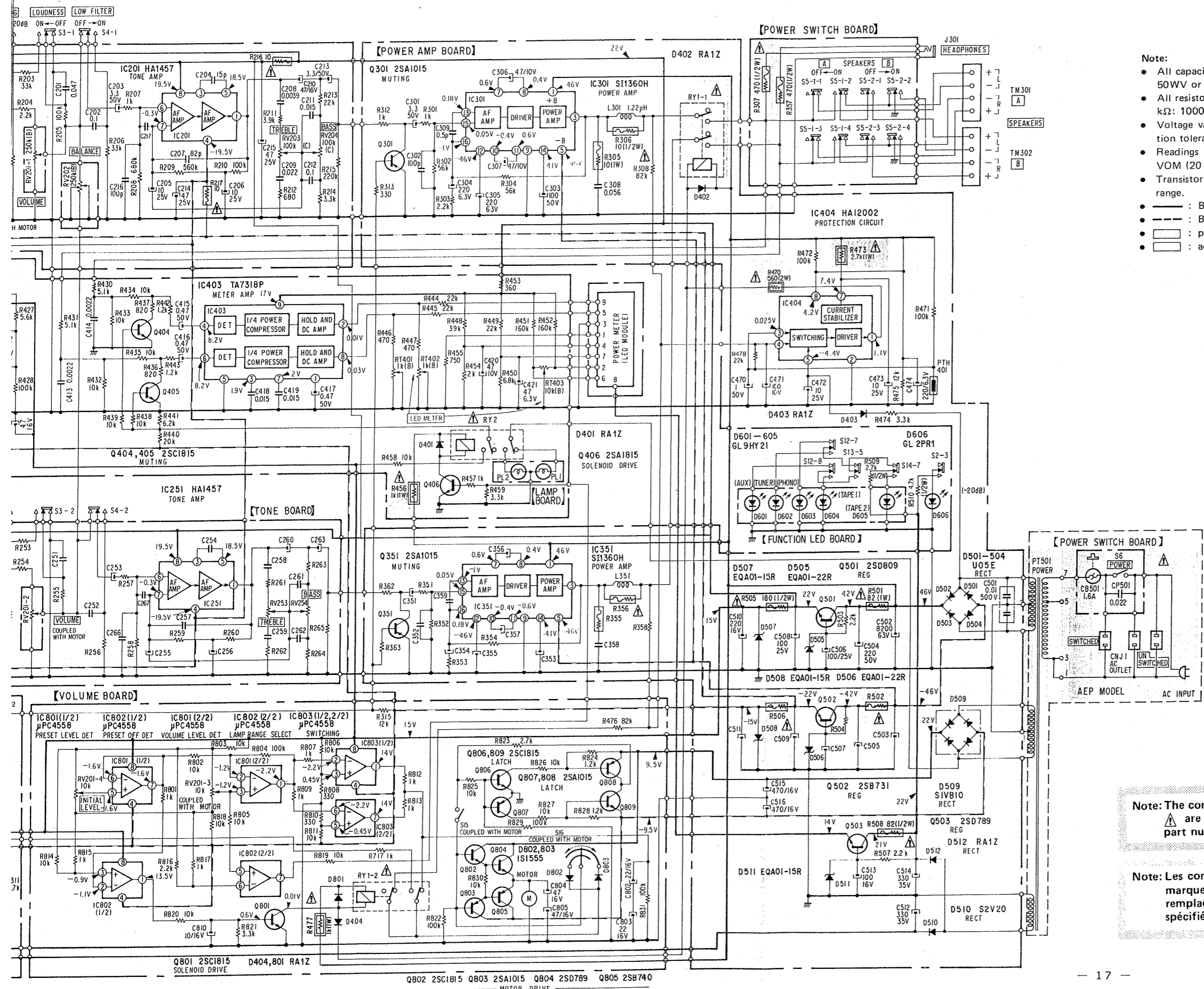



- Note:**
- All capacitors are in μF unless otherwise noted. pF : μpF
 - All resistors are in ohms, $\frac{1}{4}\text{W}$ unless otherwise noted. $\text{k}\Omega$: 1000Ω ; $\text{M}\Omega$: $1000\text{k}\Omega$
 - Voltage variations may be noted due to normal production tolerances.
 - Readings are taken under no-signal conditions with a VOM ($20\text{k}\Omega/\text{V}$).
 - Transistor base-emitter voltages are measured on the 2.5V range.
- — : B+ bus.
 - - - - : B- bus.
 - □ : panel designation.
 - □ : adjustment for repair.

Note: The components identified by shading and mark are critical for safety. Replace only with part number specified.

Note: Les composants identifiés par une trame et une marque sont critiques pour la sécurité. Ne les remplacer que par une pièce portant le numéro spécifié.

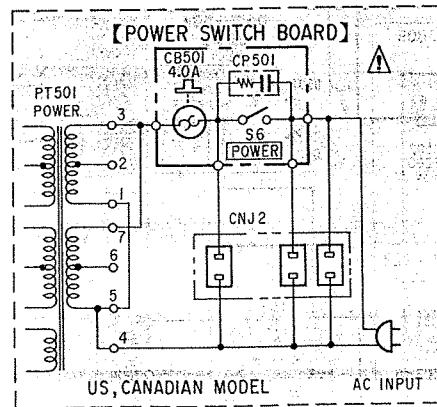
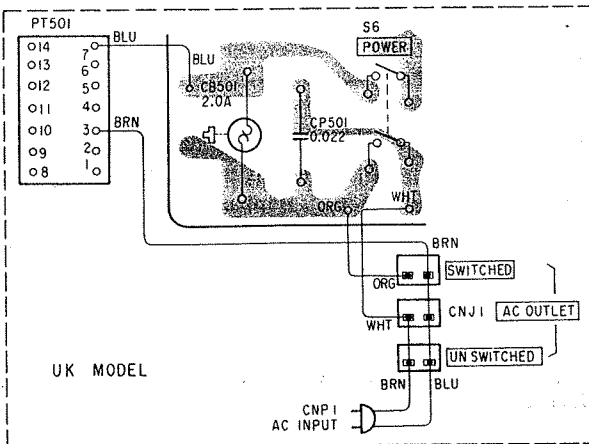
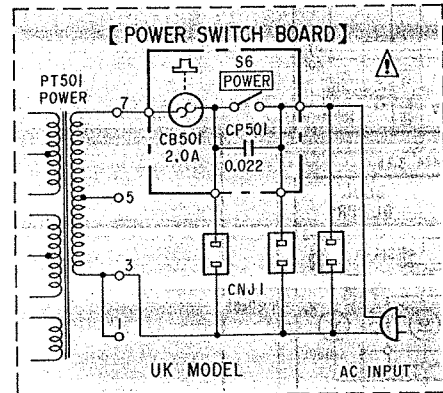
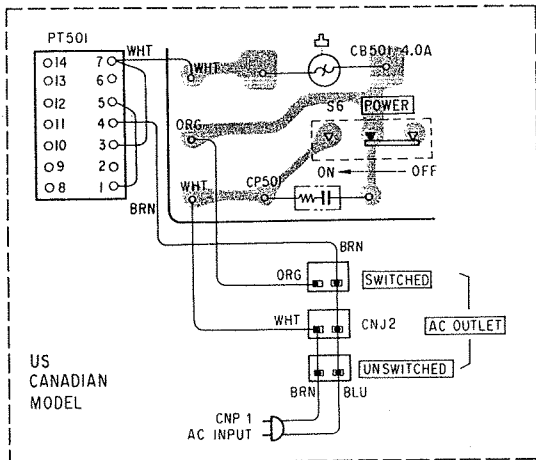
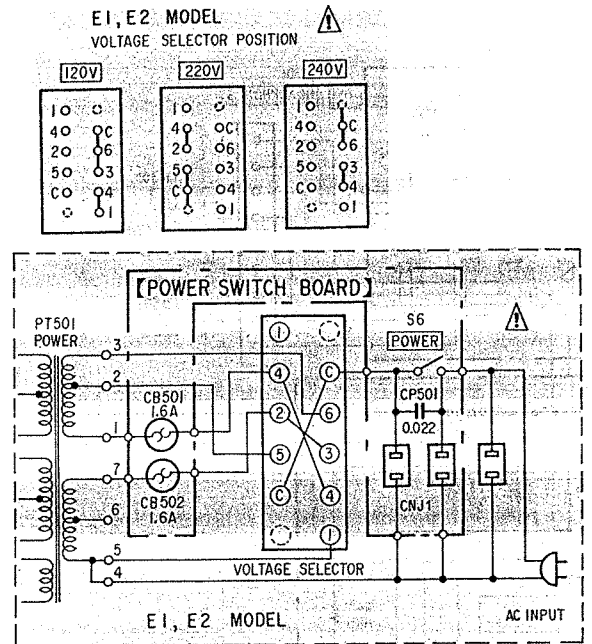
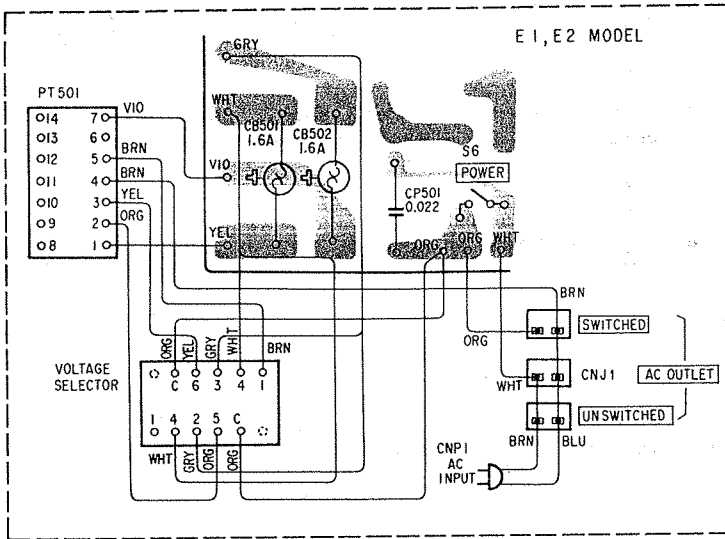
4-3. POWER SUPPLY SECTION



Note: The components identified by shading and mark  are critical for safety. Replace only with part number specified.

Note: Les composants identifiés par une trame et une marque  sont critiques pour la sécurité. Ne les remplacer que par une pièce portant le numéro spécifié.