

TA-717/717M/818/818M

SERVICE MANUAL

US Model
AEP Model
UK Model
TA-717M/818M

Canadian Model
TA-717M

E Model
TA-717/818



Photo: TA-818M

TA-717/818 are the amplifier section in FH-717R/818R.

TA-717M/818M are the amplifier section in MHC2200/2200CD/3300/3300CD.

SPECIFICATIONS

AUDIO POWER SPECIFICATIONS

(for US, Canadian model)

POWER OUTPUT AND TOTAL HARMONIC DISTORTION:

With 6 ohm loads both channels driven, from 50 – 20,000 Hz; rated 22 watts: 717M, 30 watts: 818M per channel minimum RMS power, with no more than 1% total harmonic distortion from 250 milliwatts to rated output.

Continuous RMS power output (AEP, UK, West Germany, Italian model)

TA-717M

30 + 30 watts (6 ohms, at 1 kHz, 5% THD)

TA-818M

45 + 45 watts (6 ohms, at 1 kHz, 5% THD)

Peak music power output (E, Saudi Arabia model)

380 watts (5% THD, 6 ohms)

	Sensitivity	Impedance
AUX (US, Canadian model) (phono jacks)	450 mV	50 kilohms
CD (AEP, UK, E West Germany Italian, Saudi Arabia model) (phono jacks)		
MIC (minijack)	1 mV	600 ohms
PHONO (phono jacks)	2.5 mV	47 kilohms

Outputs

HEADPHONES (stereo minijack)	Accepts headphones of 8 ohms or more.
SPEAKER	Accepts speakers of 6 to 16 ohms.

Power requirements

US, Canadian model: 120 V AC, 60 Hz

AEP, UK, West Germany, Italian model:
220 V, 50/60 Hz

UK model: 240 V, 50 Hz

E model: 120, 220 or 240 V AC adjustable,
50/60 Hz

Power consumption

	TA-717/717M	TA-818/818M
US model	75 W	85 W
Canadian model	130 W	
AEP, UK, West Germany Italian model	85 W	105 W
UK model	165 W	225 W
E, Saudi Arabia model	100 W	105 W

Dimensions/Weight

	Dimensions* (w/h/d)	Weight
TA-717/717M	Approx. 225 x 120 x 270 mm (8 ⁷ / ₈ x 4 ³ / ₄ x 10 ³ / ₄ inches)	Approx. 3.8 kg (8 lb 6 oz) net
TA-818/818M		Approx. 4.3 kg (9 lb 8 oz) net

* incl. projecting parts and controls

INTEGRATED STEREO AMPLIFIER
SONY®



SECTION 1 SERVICING NOTES

MODEL IDENTIFICATION

— Specification Label —

TA-717
TA-717M
TA-818
TA-818M

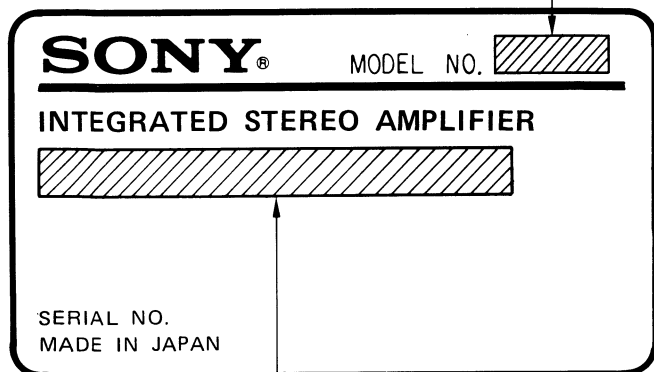

US, Canadian Model: AC: 120 V ~ 60 Hz
 AEP, West Germany, Italian Model:
 AC: 220 V ~ 50/60 Hz
 UK Model: AC: 240 V ~ 50/60 Hz
 E, Saudi Arabia Model: AC: 120/220/240 V ~ 50/60 Hz

On operating voltage

Before operating the unit, check that the operating voltage of your unit is identical with the voltage of your local power supply.

Where purchased	Operating voltage
US, Canadian Model	120 V AC
UK Model	240 V AC
AEP, West Germany Italian Model	220 V AC
E, Saudi Arabia Model	120 V, 220 V or 240 V AC adjustable by AC voltage selector

SAFETY CHECK-OUT

After correcting the original service problem, perform the following safety check before releasing the set to the customer:

Check the antenna terminals, metal trim, “metallized” knobs, screws, and all other exposed metal parts for AC leakage. Check leakage as described below.

LEAKAGE TEST

The AC leakage from any exposed metal part to earth ground and from all exposed metal parts to any exposed metal part having a return to chassis, must not exceed 0.5 mA (500 microampers). Leakage current can be measured by any one of three methods.

1. A commercial leakage tester, such as the Simpson 229 or RCA WT-540A. Follow the manufacturers' instructions to use these instruments.
2. A battery-operated AC milliammeter. The Data Precision 245 digital multimeter is suitable for this job.
3. Measuring the voltage drop across a resistor by means of a VOM or battery-operated AC voltmeter. The “limit” indication is 0.75 V, so analog meters must have an accurate low-voltage scale. The Simpson 250 and Sanwa SH-63Trd are examples of a passive VOM that is suitable. Nearly all battery operated digital multimeters that have a 2V AC range are suitable. (See Fig. A)

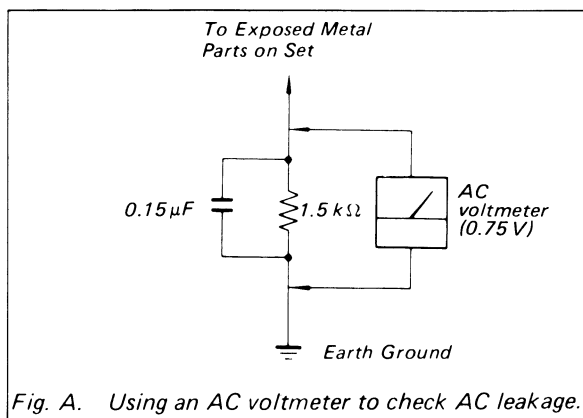

Fig. A. Using an AC voltmeter to check AC leakage.

SAFETY-RELATED COMPONENT WARNING!!

COMPONENTS IDENTIFIED BY MARK OR DOTTED LINE WITH MARK ON THE SCHEMATIC DIAGRAMS AND IN THE PARTS LIST ARE CRITICAL TO SAFE OPERATION. REPLACE THESE COMPONENTS WITH SONY PARTS WHOSE PART NUMBERS APPEAR AS SHOWN IN THIS MANUAL OR IN SUPPLEMENTS PUBLISHED BY SONY.

ATTENTION AU COMPOSANT AYANT RAPPORT À LA SÉCURITÉ!

LES COMPOSANTS IDENTIFIÉS PAR UNE MARQUE SUR LES DIAGRAMMES SCHÉMATIQUES ET LA LISTE DES PIÈCES SONT CRITIQUES POUR LA SÉCURITÉ DE FONCTIONNEMENT. NE REMPLACER CES COMPOSANTS QUE PAR DES PIÈCES SONY DONT LES NUMÉROS SONT DONNÉS DANS CE MANUEL OU DANS LES SUPPLÉMENTS PUBLIÉS PAR SONY.

SECTION 2 GENERAL

FUNCTION OF CONTROLS

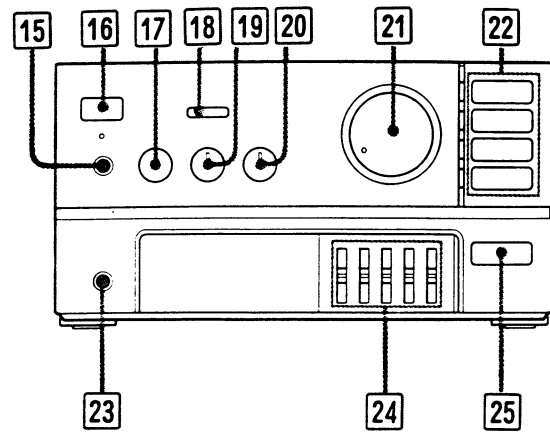

- 15 MIC (microphone) jack (minijack)
- 16 POWER switch
- 17 MIC LEVEL (microphone level) control
- 18 DBFB (Dynamic Bass Feedback) button
- 19 DBFB LEVEL control
- 20 BALANCE control
- 21 VOLUME control
- 22 Function selectors
- 23 HEADPHONES jack (stereo minijack)
- 24 GRAPHIC EQUALIZER controls
- 25 EQUALIZATION switch

SECTION 3 DIAGRAMS

3-1. IC BLOCK DIAGRAMS

IC002 M4052BP

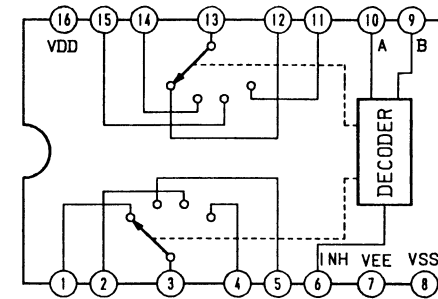

IC401 LC7566

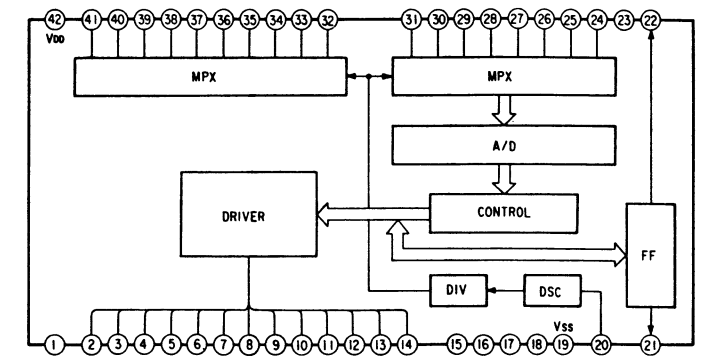

IC404 LB1639

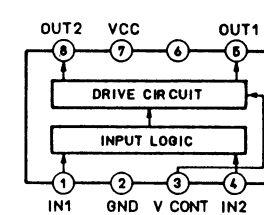

IC802 μPC1237HA

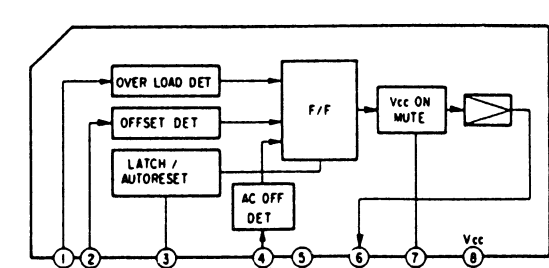

3-2. SEMICONDUCTOR LEAD LAYOUTS

M5F7806
M5F7808
M5F7812
M5F7908

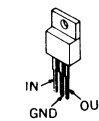

STK4142MK2
STK4152II

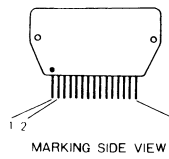

2SA733
2SC1387
2SC1841-PA
2SD1387



RBV-402-01
RBV-602-01

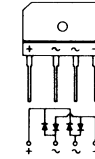

SEL1210W



M5F7924

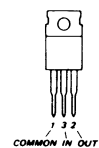

DTC114ES
2SC3400
2SC4048



2SC2785



US1060M
UZL-7M3
UZP-3.3BB
UZ-4.3BSB
10E2N

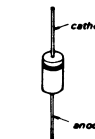

SEL1910W

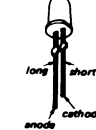

M5218L
μPC1237HA



HZS11B-3L

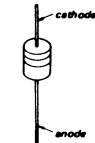

SEL4214W

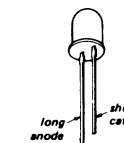

Note
The
fied
ted
are c
Repl
num

SECTION 3
DIAGRAMS

3-1. IC BLOCK DIAGRAMS

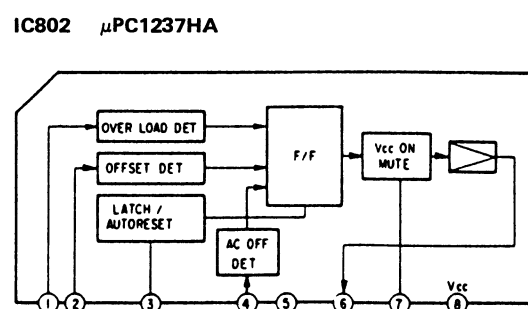
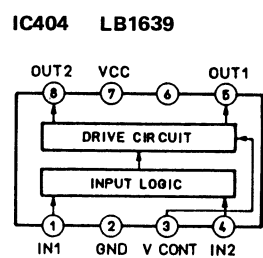
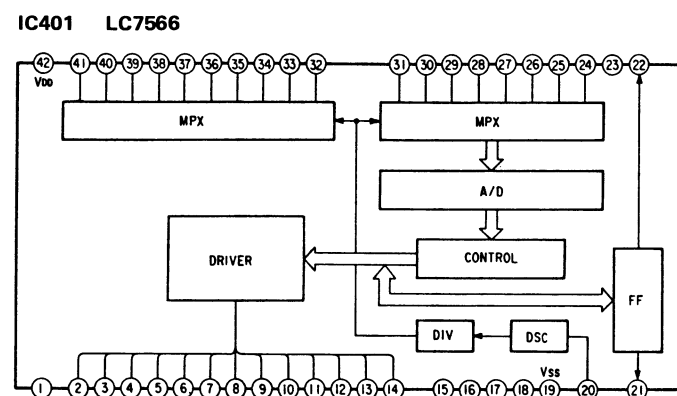
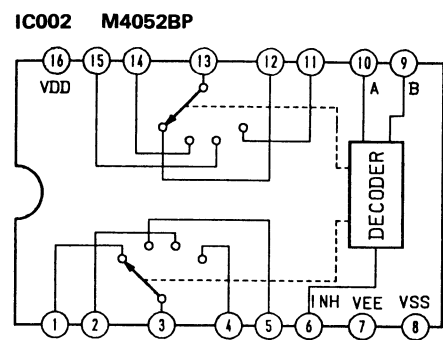

Note on Schematic Diagram:

- All capacitors are in μF unless otherwise noted. pF : $\mu\mu\text{F}$ 50WV or less are not indicated except for electrolytics and tantalums.
- All resistors are in Ω and $1/4\text{W}$ or less unless otherwise specified.
- \triangle : internal component.
- \square : nonflammable resistor.
- \square : fusible resistor.
- --- : B+ Line
- --- : B- Line
- Voltages are dc with respect to ground under no-signal conditions.
- Voltages are taken with a VOM (Input impedance $10\text{M}\Omega$). Voltage variations may be noted due to normal production tolerances.
- Signal path.
- \Rightarrow : CD

Note:
The components identified by mark \triangle or dotted line with mark \triangle are critical for safety. Replace only with part number specified.

Note:
Les composants identifiés par une marque \triangle sont critiques pour la sécurité. Ne les remplacer que par une pièce portant le numéro spécifié.

• Semiconductor Location

Ref. No.	Location	Ref. No.	Location
D101	G-2	IC001	H-8
D201	I-5	IC002	J-7
D202	I-5	IC003	J-2
D203	I-4	IC101	H-3
D204	I-4	IC201	H-6
D401	E-11	IC202	H-6
D402	E-11	IC203	J-4
D403	C-15	IC301	D-9
D404	B-9	IC302	C-9
D405	B-9	IC303	C-12
D406	C-9	IC351	E-8
D407	C-9	IC401	E-13
D408	B-13	IC402	C-11
D409	B-13	IC403	D-14
D410	B-13	IC801	C-19
D411	D-11	IC802	B-22
D412	D-13	IC901	H-20
D413	D-14	IC902	H-19
D414	D-12		
D415	D-11	Q101	I-4
D416	D-11	Q102	G-3
D417	B-13	Q301	C-13
D418	B-15	Q302	C-14
D419	C-11	Q303	C-5
D420	C-11	Q351	C-13
D421	E-14	Q353	C-5
D422	B-2	Q401	C-10
D423	C-12	Q402	B-15
D801	B-19	Q403	C-10
D821	B-18	Q404	E-15
D822	B-21	Q406	C-4
D851	B-19	Q801	B-20
D901	H-18	Q802	B-21
D902	G-17	Q901	G-18
D903	H-14		
D904	G-19		
D905	H-19		
D906	G-19		
D907	H-19		
D911	I-19		

3-2. SEMICONDUCTOR LEAD LAYOUTS

M5F7806
M5F7808
M5F7812
M5F7908

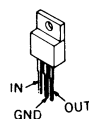

STK4142MK2
STK4152II

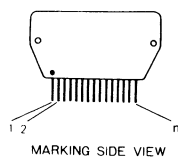

2SA733
2SC1387
2SC1841-PA
2SD1387



RBV-402-01
RBV-602-01

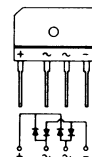

SEL1210W

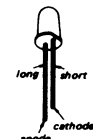

M5F7924

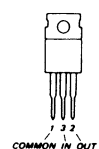

DTC114ES
2SC3400
2SC4048



2SC2785

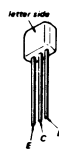

US1060M
UZL-7M3
UZP-3.3BB
UZ-4.3BSB
10E2N

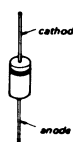

SEL1910W



M5218L
μPC1237HA

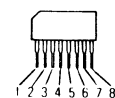

HZS11B-3L

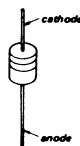

SEL4214W

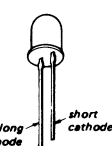

[Note on Inserting the Cord to the Connector on Tuner Board]

- Insert the cord to the connector fitting Pin ① of the cord in accordance with the white mark on the board at the connector as shown in the figure.

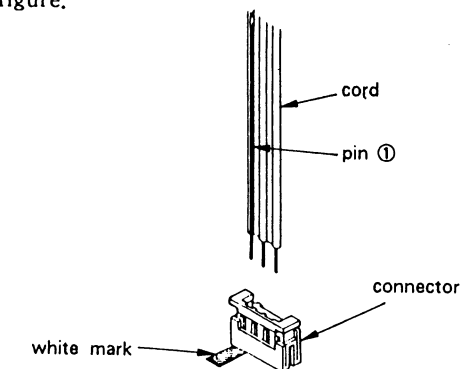

3-3. PRINTED WIRING BOARDS • See page 4 for Semiconductor Lead Layouts.

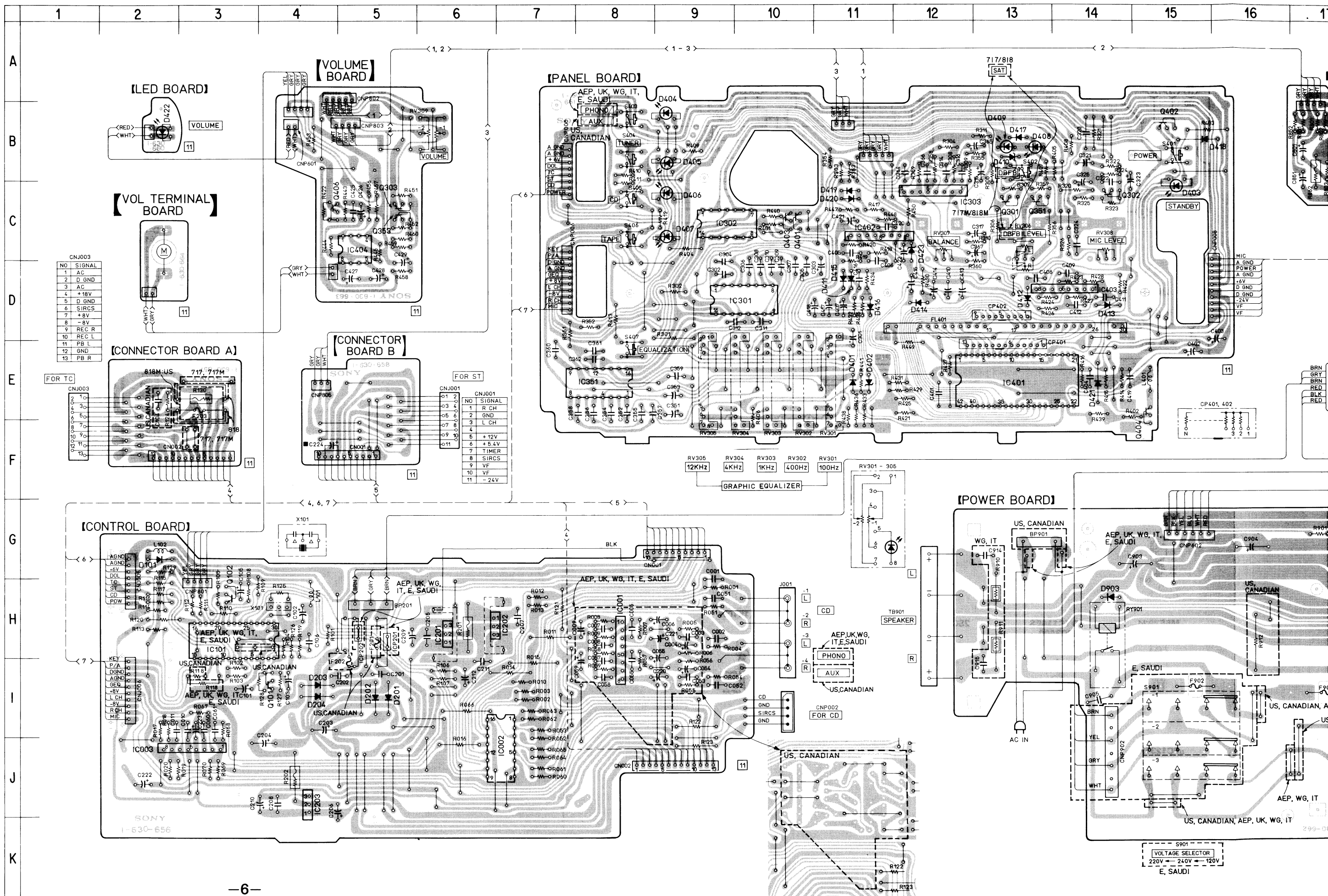

CNJ003

NO	SIGNAL
1	AC
2	D GND
3	AC
4	+18V
5	D GND
6	SIRCS
7	+8V
8	-8V
9	REC R
10	REC L
11	PB L
12	GND
13	PB R

CNJ001

NO	SIGNAL
1	R CH
2	GND
3	L CH
4	
5	+12V
6	+5.4V
7	TIMER
8	SIRCS
9	VF
10	VF
11	-24V

S901
VOLTAGE SELECTOR
220V ← 240V ← 120V
E, SAUDI

[PANEL BOARD]

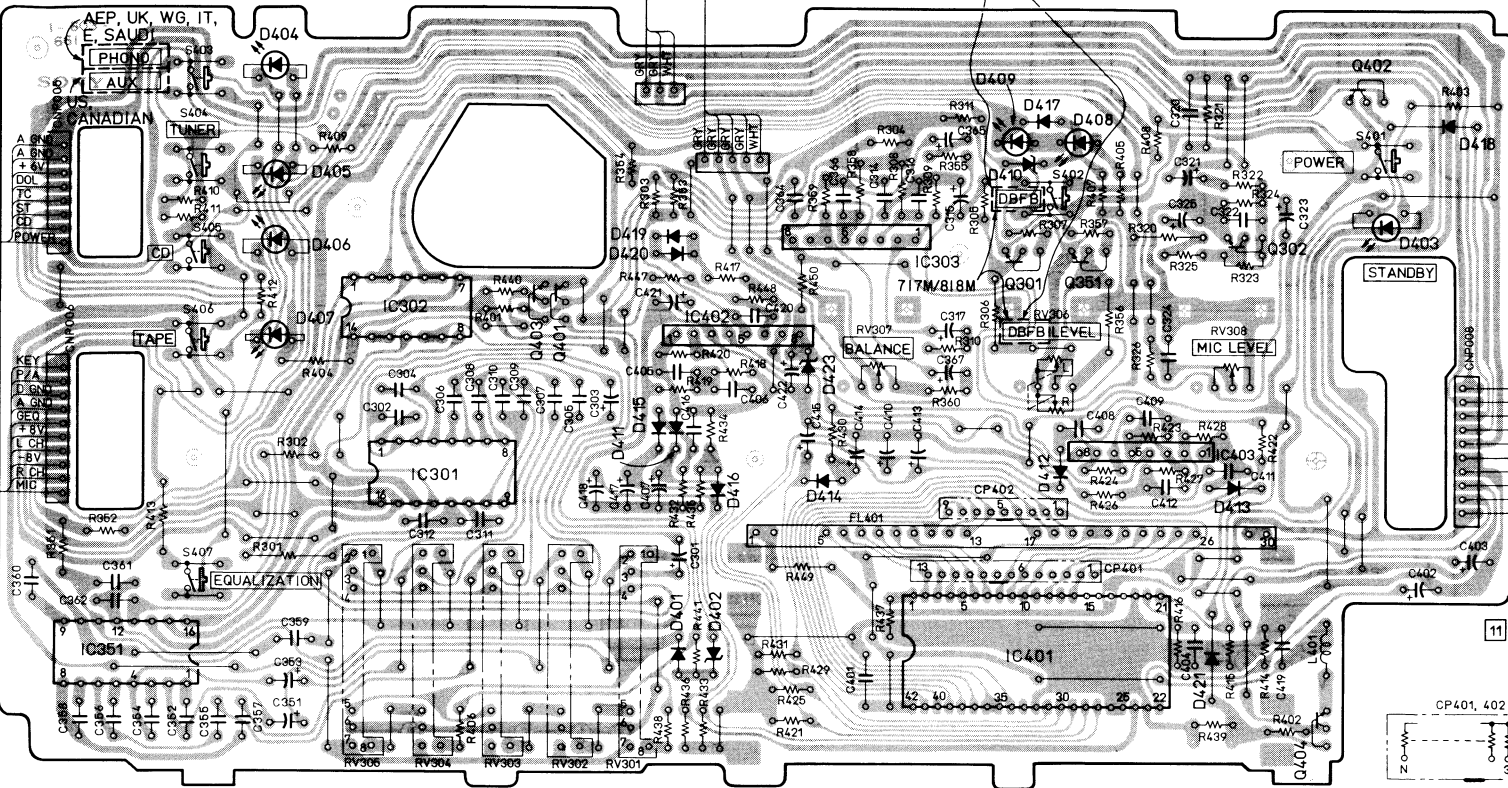

[POWER AMP BOARD]

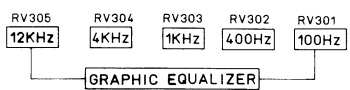
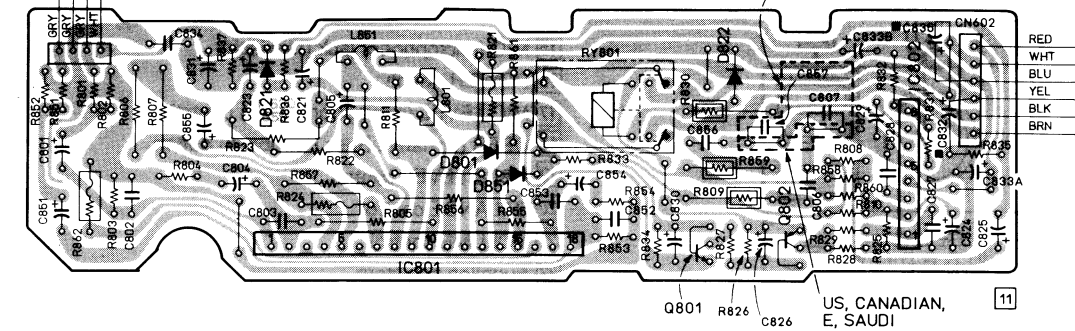

[POWER BOARD]

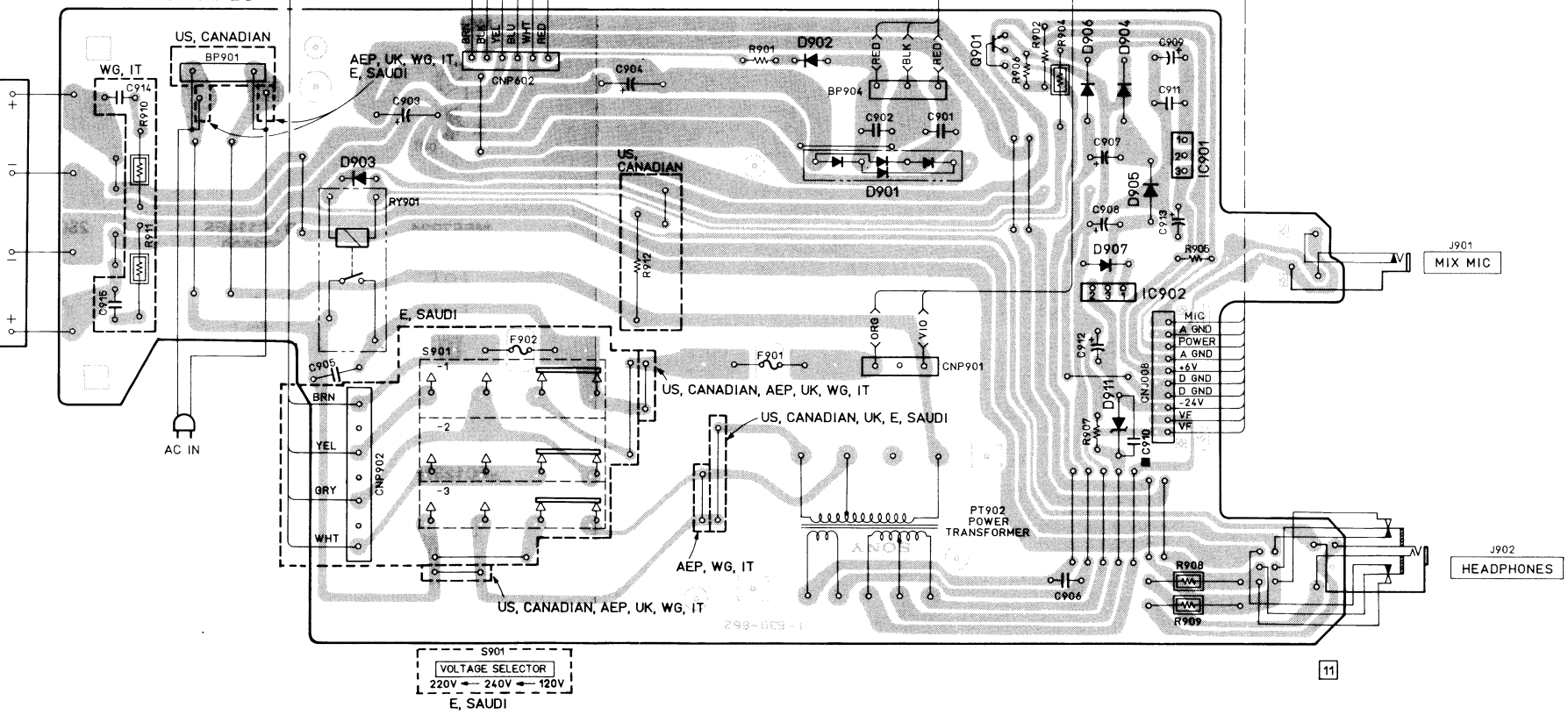

- 001 GNAL
- CH
- ND
- CH
- 12V
- 5.4V
- IMER
- IRCS
- F
- 24V

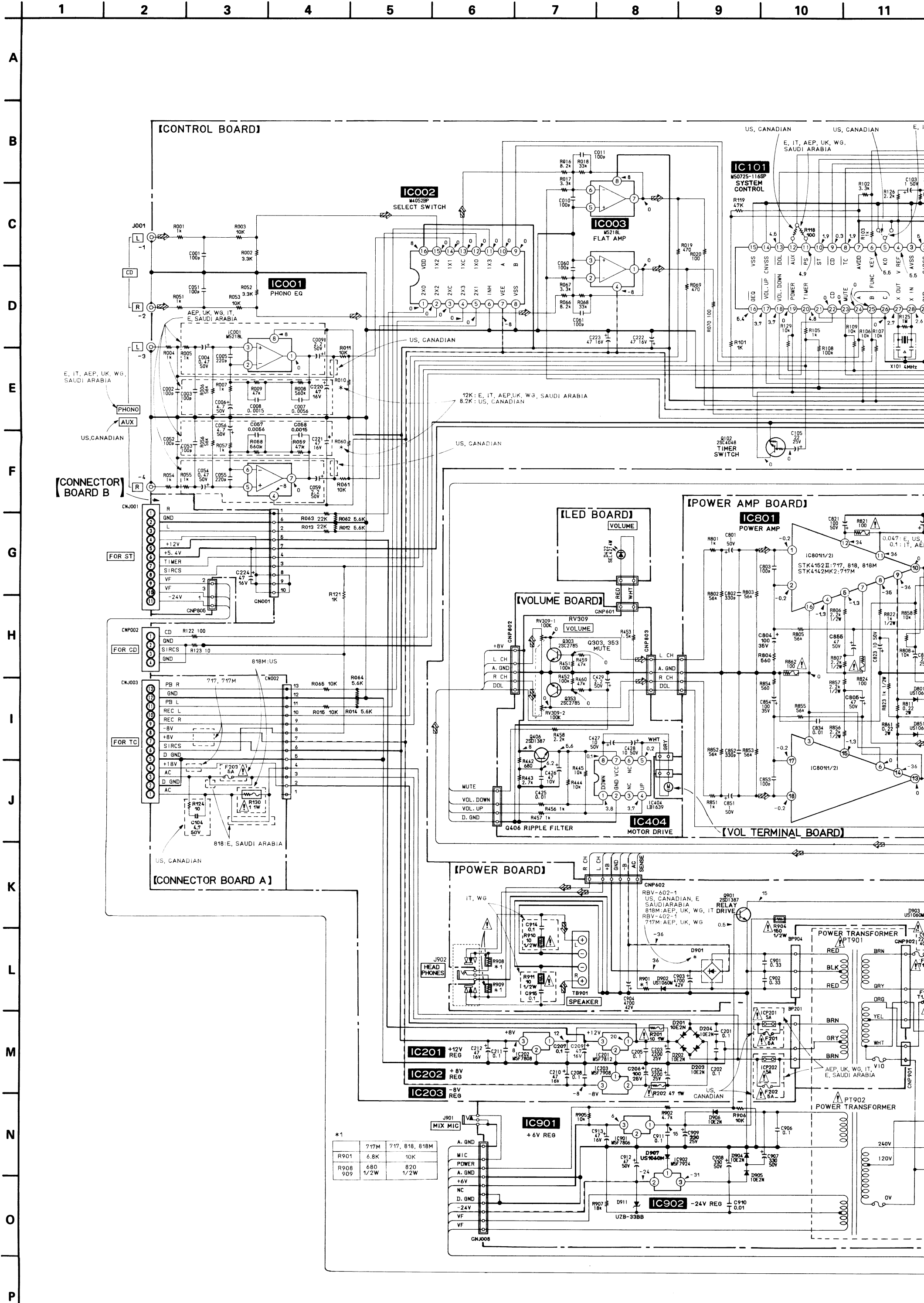

*1	717M	717, 818, 818M
R901	6.8K	10K
R908	680	820
R909	1/2W	1/2W

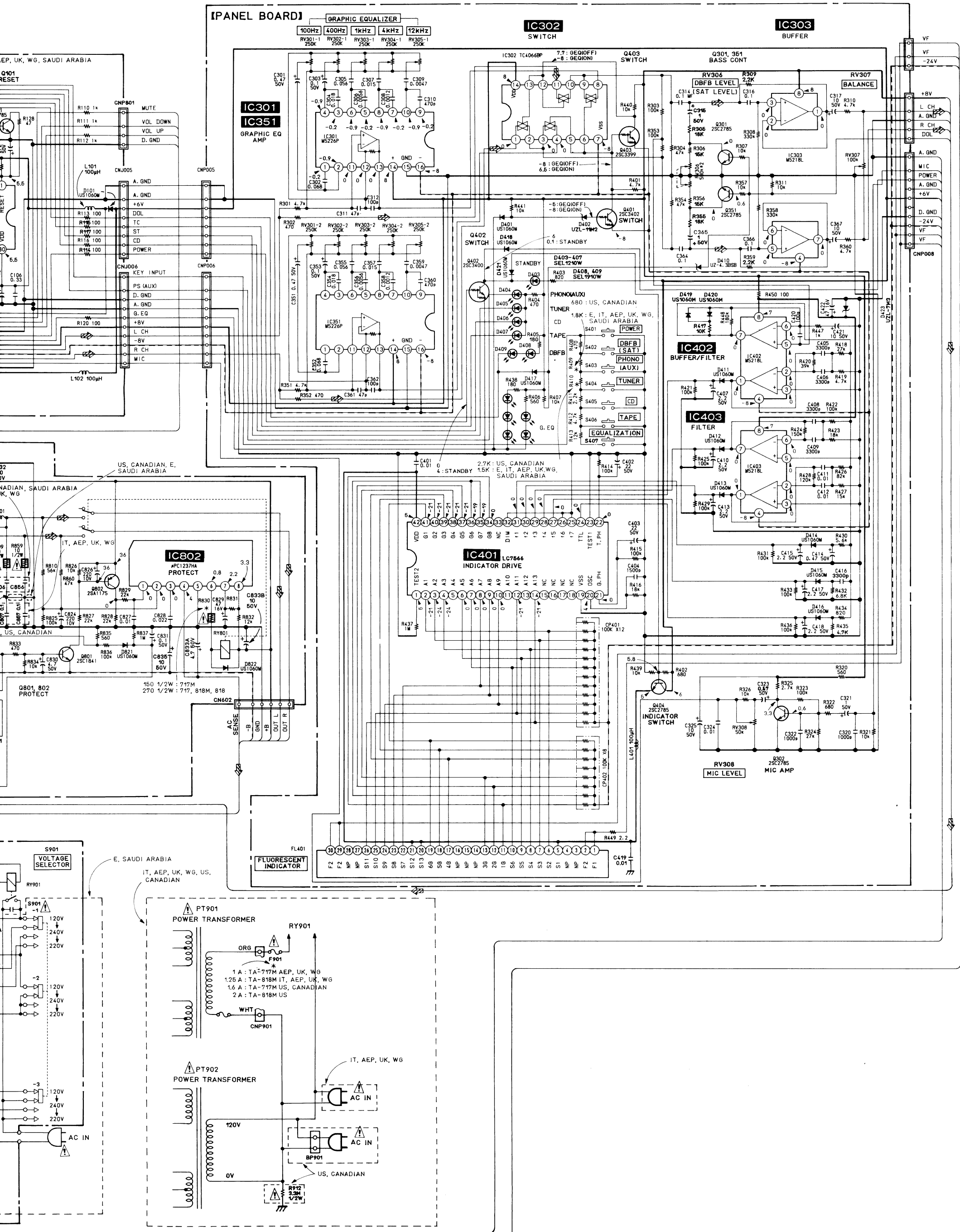

SECTION 4 EXPLODED VIEW

NOTE:

- The mechanical parts with no reference number in the exploded views are not supplied.
- The construction parts of an assembled part are indicated with a collation number in the remark column.
- Items marked "*" are not stocked since they are seldom required for routine service. Some delay should be anticipated when ordering these items.

- Due to standardization, parts with part number suffix -XX and -X may be different from the parts specified in the components used on the set.
- Color Indication of Appearance Parts Example:
 (RED) ... KNOB, BALANCE (WHITE)
 ↑ Cabinet's Color ↑ Parts' Color

The components identified by mark or dotted line with mark are critical for safety. Replace only with part number specified.

Les composants identifiés par une marque sont critiques pour la sécurité. Ne les remplacer que par une pièce portant le numéro spécifié.

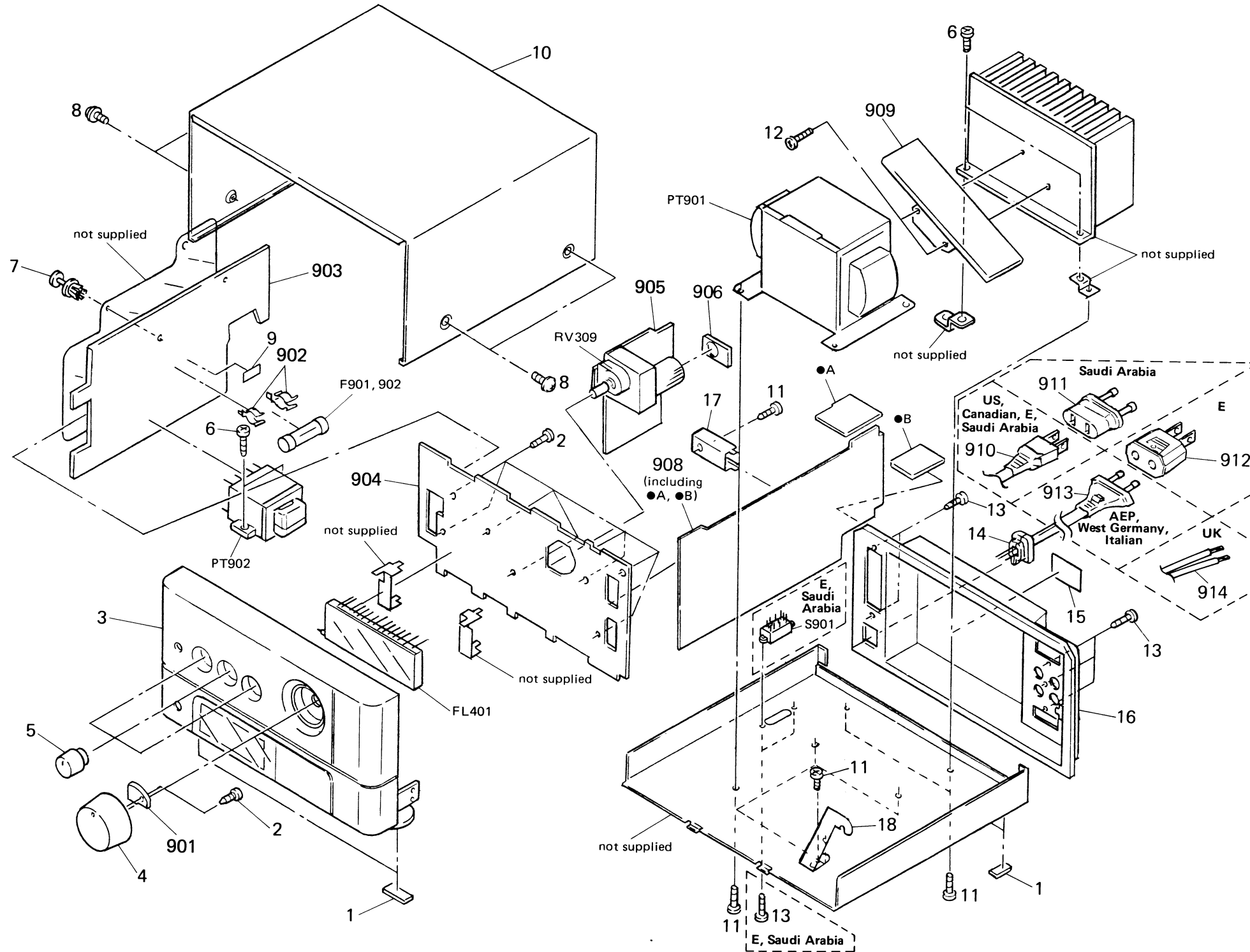

No.	Part No.	Description	Remarks	No.	Part No.	Description	Remarks
1	4-930-336-01	FOOT (FELT)		9	*3-701-946-22	(717M:US,Canadian)...LABEL (1.6A 125V), FUSE	
2	4-928-635-01	SCREW, +BV (2.6X8) TAPPING			*3-701-946-23	(818M:US)...LABEL (2A 125V), FUSE	
3	X-4930-301-1	(818M:US)...PANEL ASSY, FRONT			*3-701-947-11	(717M:AEP,UK,WG)...LABEL (1A), FUSE	
	X-4930-302-1	(818)...PANEL ASSY, FRONT		10	4-930-355-01	(818M:US)...CASE	
	X-4930-304-1	(717)...PANEL ASSY, FRONT			4-930-355-21	(717M,818M:AEP,UK,WG,IT)...CASE	
	X-4930-305-1	(717M:US,Canadian)...PANEL ASSY, FRONT			4-930-355-31	(E,Saudi Arabia)...CASE	
	X-4930-308-1	(818M:AEP,UK,WG,IT)...PANEL ASSY, FRONT		11	7-682-547-04	SCREW +BVTT 3X6 (S)	
	X-4930-309-1	(717M:AEP,UK,WG)...PANEL ASSY, FRONT		12	7-685-650-79	SCREW +BVTP 3X16 TYPE2 IT-3	
4	X-4930-303-1	KNOB ASSY		13	7-685-646-79	SCREW +BVTP 3X8 TYPE2 N-S	
5	4-930-323-01	KNOB		14	3-703-571-00	(E)...BUSHING (S) (4516), CORD	
6	7-682-548-04	SCREW +BVTT 3X8 (S)			*3-703-244-00	(EXCEPT for E)...BUSHING (2104), CORD	
7	4-812-134-11	RIVET NYLON, 3.5		15	*4-930-301-01	(717M:US)...LABEL, MODEL NUMBER (U)	
8	3-704-366-01	SCREW (CASE) (M3X8)			*4-930-302-01	(717M:AEP)...LABEL, MODEL NUMBER (AE)	
					*4-930-303-01	(717M:WG)...LABEL, MODEL NUMBER (AE4)	
					*4-930-304-01	(717M:UK)...LABEL, MODEL NUMBER (UK)	
					*4-930-305-01	(717)...LABEL, MODEL NUMBER (E2/E3)	
					*4-930-306-01	(717M:Canadian)...LABEL, MODEL NUMBER (C)	
					*4-930-307-01	(818M:US)...LABEL, MODEL NUMBER (U)	
					*4-930-308-01	(818M:IT)...LABEL, MODEL NUMBER (IT)	
					*4-930-309-01	(818M:AEP)...LABEL, MODEL NUMBER (AE)	
					*4-930-310-01	(818M:WG)...LABEL, MODEL NUMBER (AE4)	
					*4-930-311-01	(818M:UK)...LABEL, MODEL NUMBER (UK)	
					*4-930-312-01	(818)...LABEL, MODEL NUMBER (E2/E3)	
				16	*4-930-328-01	PANEL, BACK	
				17	*3-309-144-21	HEAT SINK	
				18	*3-327-845-01	BRACKET	
				901	*1-630-660-11	PC BOARD, LED	
				902	*1-533-213-31	HOLDER, FUSE	
				903	*1-630-662-11	PC BOARD, POWER	
				904	*A-4333-306-A	(AEP,UK,E,Saudi Arabia) ...MOUNTED PCB, PANEL	
					*A-4333-312-A	(WG,IT)...MOUNTED PCB, PANEL	
					*A-4333-317-A	(US,Canadian)...MOUNTED PCB, PANEL	
				905	*1-630-663-11	PC BOARD, VOL	
				906	*1-630-664-11	PC BOARD, VOL TERMINAL	
				909	△.1-630-659-11	PC BOARD, POWER AMP	
				908	*A-4333-305-A	(717,717M:AEP,UK)...MOUNTED PCB, CONTROL	
					*A-4333-311-A	(717M:WG)...MOUNTED PCB, CONTROL	
					*A-4333-316-A	(717M:US,Canadian)...MOUNTED PCB, CONTROL	
					*A-4333-326-A	(818M:WG,IT)...MOUNTED PCB, CONTROL	
					*A-4333-363-A	(818,818M:AEP,UK)...MOUNTED PCB, CONTROL	
					*A-4333-389-A	(818M:US)...MOUNTED PCB, CONTROL	
				909	△.1-630-659-11	PC BOARD, POWER AMP	
				910	△.1-551-188-XX	(E)...CORD, POWER	
					△.1-557-577-11	(US,Canadian)...CORD, POWER	
				911	△.1-526-565-00	(E)...AC PLUG ADAPTOR	
				912	△.1-506-401-11	(Saudi Arabia)...ADAPTOR, CONVERSION	
				913	△.1-555-750-00	(AEP,WG,IT,Saudi Arabia)...CORD, POWER	
				914	△.1-556-037-00	(UK)...CORD, POWER	
				F901	△.1-532-285-00	(E,Saudi Arabia,818M:AEP,UK,WG,IT) ...FUSE, TIME-LAG (1.25A)	
				F901	△.1-532-078-00	(717M:AEP,UK)...FUSE, TIME-LAG (1A)	
				F901	△.1-532-742-11	(717M:US,Canadian)...FUSE, GLASS TUBE (1.6A)	
				F901	△.1-532-743-11	(818M:US)...FUSE, GLASS TUBE(2A)	
				F902	△.1-532-285-00	(E,Saudi Arabia)...FUSE, TIME-LAG(1.25A)	
				FL401	1-519-516-11	INDICATOR TUBE, FLUORESCENT	
				PT901	△.1-449-561-11	(E,Saudi Arabia)...TRANSFORMER, POWER	
				PT901	△.1-449-562-11	(717M:UK)...TRANSFORMER, POWER	
				PT901	△.1-449-563-11	(717M:AEP,UK)...TRANSFORMER, POWER	
				PT901	△.1-449-564-11	(717M:US,Canadian)...TRANSFORMER, POWER	
				PT901	△.1-449-568-11	(818M:UK)...TRANSFORMER, POWER	
				PT901	△.1-449-569-11	(818M:AEP,WG,IT)...TRANSFORMER, POWER	
				PT901	△.1-449-570-11	(818M:US)...TRANSFORMER, POWER	
				PT902	△.1-449-565-11	(E,Saudi Arabia)...TRANSFORMER, POWER	
				PT902	△.1-449-566-11	(AEP,UK,WG,IT)...TRANSFORMER, POWER	
				PT902	△.1-449-567-11	(US,Canadian)...TRANSFORMER, POWER	

NOTE:

- Du list the
- Ite are del iter
- If suc circ res

Ref.No.
901
902
903
904
905
906
908
909
910
911
912
913
914
BP201
BP901
BP904
C001
C002
C003
C004
C005
C006
C007
C008
C009
C010
C011
C051
C052

No.	Part No.	Description	Remarks
1	4-930-336-01	FOOT (FELT)	
2	4-928-635-01	SCREW, +BV (2.6X8) TAPPING	
3	X-4930-301-1 X-4930-302-1 X-4930-304-1	(818M:US)...PANEL ASSY, FRONT (818)...PANEL ASSY, FRONT (717)...PANEL ASSY, FRONT	
	X-4930-305-1 X-4930-308-1 X-4930-309-1	(717M:US,Canadian)...PANEL ASSY, FRONT (818M:AEP,UK,WG,IT)...PANEL ASSY, FRONT (717M:AEP,UK,WG)...PANEL ASSY, FRONT	
4	X-4930-303-1	KNOB ASSY	
5	4-930-323-01	KNOB	
6	7-682-548-04	SCREW +BVTT 3X8 (S)	
7	4-812-134-11	RIVET NYLON, 3.5	
8	3-704-366-01	SCREW (CASE) (M3X8)	

No.	Part No.	Description	Remarks
9	*3-701-946-22	(717M:US,Canadian)...LABEL (1.6A 125V), FUSE	
	*3-701-946-23	(818M:US)...LABEL (2A 125V), FUSE	
	*3-701-947-11	(717M:AEP,UK,WG)...LABEL (11A), FUSE	
10	4-930-355-01	(818M:US)...CASE	
	4-930-355-21	(717M,818M:AEP,UK,WG,IT)...CASE	
	4-930-355-31	(E,Saudi Arabia)...CASE	
11	7-682-547-04	SCREW +BVTT 3X6 (S)	
12	7-685-650-79	SCREW +BVTP 3X16 TYPE2 IT-3	
13	7-685-646-79	SCREW +BVTP 3X8 TYPE2 N-S	
14	3-703-571-00	(E)...BUSHING (S) (4516), CORD	
	*3-703-244-00	(EXCEPT for E)...BUSHING (2104), CORD	
15	*4-930-301-01	(717M:US)...LABEL, MODEL NUMBER (U)	
	*4-930-302-01	(717M:AEP)...LABEL, MODEL NUMBER (AE)	
	*4-930-303-01	(717M:WG)...LABEL, MODEL NUMBER (AE4)	
	*4-930-304-01	(717M:UK)...LABEL, MODEL NUMBER (UK)	
	*4-930-305-01	(717)...LABEL, MODEL NUMBER (E2/E3)	
	*4-930-306-01	(717M:Canadian)...LABEL, MODEL NUMBER (E2/E3)	
	*4-930-307-01	(818M:US)...LABEL, MODEL NUMBER (U)	
	*4-930-308-01	(818M:IT)...LABEL, MODEL NUMBER (IT)	
	*4-930-309-01	(818M:AEP)...LABEL, MODEL NUMBER (AE)	
	*4-930-310-01	(818M:WG)...LABEL, MODEL NUMBER (AE4)	
	*4-930-311-01	(818M:UK)...LABEL, MODEL NUMBER (UK)	
	*4-930-312-01	(818)...LABEL, MODEL NUMBER (E2/E3)	
16	*4-930-328-01	PANEL, BACK	
17	*3-309-144-21	HEAT SINK	
18	*3-327-845-01	BRACKET	
901	*1-630-660-11	PC BOARD, LED	
902	*1-533-213-31	HOLDER, FUSE	
903	*1-630-662-11	PC BOARD, POWER	
904	*A-4333-306-A	(AEP,UK,E,Saudi Arabia) ...MOUNTED PCB, PANEL	
	*A-4333-312-A	(WG,IT)...MOUNTED PCB, PANEL	
	*A-4333-317-A	(US,Canadian)...MOUNTED PCB, PANEL	
905	*1-630-663-11	PC BOARD, VOL	
906	*1-630-664-11	PC BOARD, VOL TERMINAL	
908	*A-4333-305-A	(717,717M:AEP,UK)...MOUNTED PCB, CONTROL	
	*A-4333-311-A	(717M:WG)...MOUNTED PCB, CONTROL	
	*A-4333-316-A	(717M:US,Canadian) ...MOUNTED PCB, CONTROL	
	*A-4333-326-A	(818M:WG,IT)...MOUNTED PCB, CONTROL	
	*A-4333-363-A	(818,818M:AEP,UK) ...MOUNTED PCB, CONTROL	
	*A-4333-389-A	(818M:US)...MOUNTED PCB, CONTROL	
909	*1-630-659-11	PC BOARD, POWER AMP	
910	*1-551-188-XX	(E)...CORD, POWER	
	*1-557-577-11	(US,Canadian)...CORD, POWER	
911	*1-526-565-00	(E)...AC PLUG ADAPTOR	
912	*1-506-401-11	(Saudi Arabia)...ADAPTOR, CONVERSION	
913	*1-555-750-00	(AEP,WG,IT,Saudi Arabia)...CORD, POWER	
914	*1-556-037-00	(UK)...CORD, POWER	
F901	*1-532-285-00	(E,Saudi Arabia,818M:AEP,UK,WG,IT) ...FUSE, TIME-LAG (1.25A)	
	*1-532-078-00	(717M:AEP,UK)...FUSE, TIME-LAG (1A)	
	*1-532-742-11	(717M:US,Canadian)...FUSE, GLASS TUBE (1.6A)	
	*1-532-743-11	(818M:US)...FUSE, GLASS TUBE(2A)	
F902	*1-532-285-00	(E,Saudi Arabia)...FUSE, TIME-LAG(1.25A)	
FL401	1-519-516-11	INDICATOR TUBE, FLUORESCENT	
PT901	*1-449-561-11	(E,Saudi Arabia)...TRANSFORMER, POWER	
	*1-449-562-11	(717M:UK)...TRANSFORMER, POWER	
	*1-449-563-11	(717M:AEP,UK)...TRANSFORMER, POWER	
	*1-449-564-11	(717M:US,Canadian)...TRANSFORMER, POWER	
	*1-449-568-11	(818M:UK)...TRANSFORMER, POWER	
	*1-449-569-11	(818M:AEP,WG,IT)...TRANSFORMER, POWER	
	*1-449-570-11	(818M:US)...TRANSFORMER, POWER	
PT902	*1-449-565-11	(E,Saudi Arabia)...TRANSFORMER, POWER	
	*1-449-566-11	(AEP,UK,WG,IT)...TRANSFORMER, POWER	
	*1-449-567-11	(US,Canadian)...TRANSFORMER, POWER	

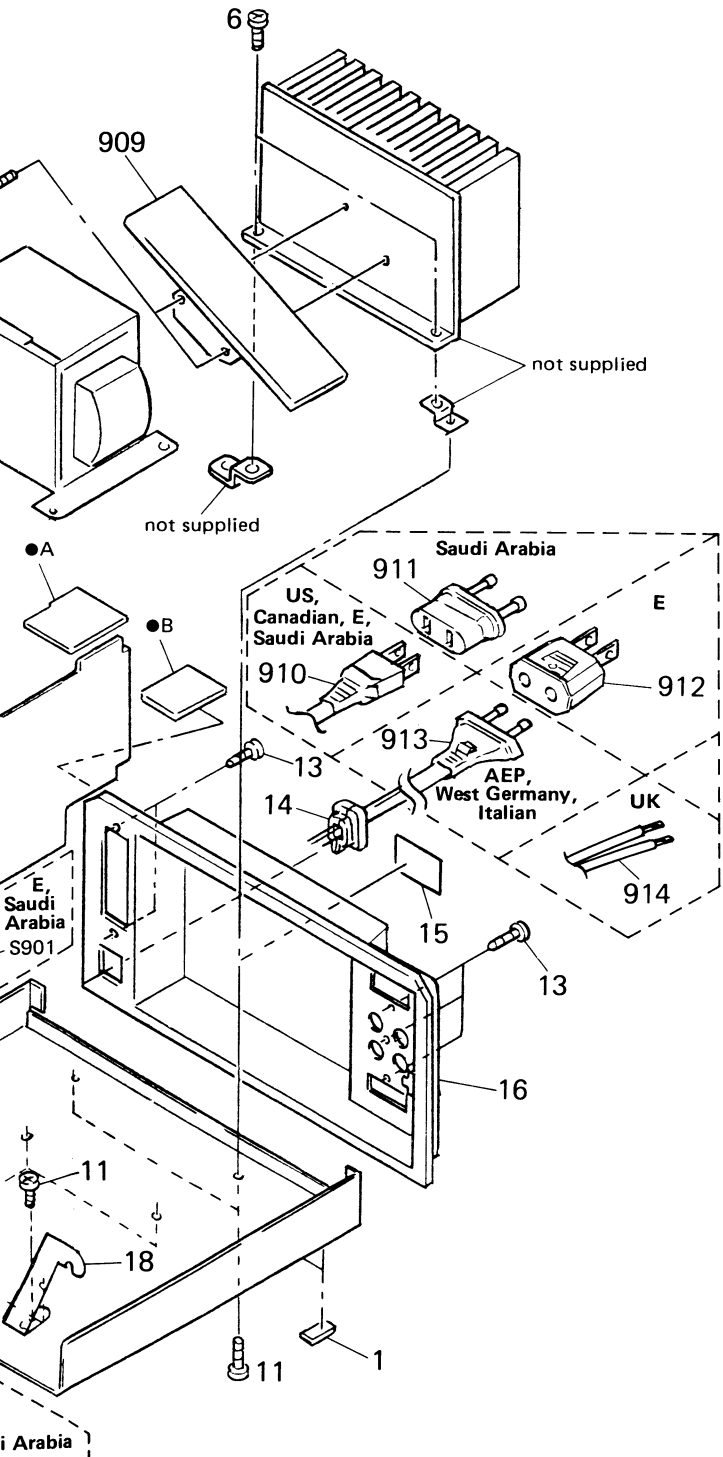

SECTION 5 ELECTRICAL PARTS LIST

NOTE:

- Due to standardization, replacements in the parts list may be different from the parts specified in the diagrams or the components used on the set.
- Items marked "*" are not stocked since they are seldom required for routine service. Some delay should be anticipated when ordering these items.
- If there are two or more same circuits in a set such as a stereophonic machine, only typical circuit parts may be indicated and capacitors and resistors in other same circuits may be omitted.

CAPACITORS:
MF: μF , PF: $\mu\mu F$.

RESISTORS
• All resistors are in ohms.
• F: Nonflammable

COILS
• MMH: mH, UH: μH

SEMICONDUCTORS

In each case, U: μ , for example:
UA...: μA , UPA...: μPA ,
UPC...: μPC , UPD...: μPD .

The components identified by mark Δ or dotted line with mark Δ are critical for safety. Replace only with part number specified.

Les composants identifiés par une marque Δ sont critiques pour la sécurité. Ne les remplacer que par une pièce portant le numéro spécifié.

Ref.No.	Part No.	Description	Ref.No.	Part No.	Description
901	*1-630-660-11	PC BOARD, LED	C053	1-162-282-31	(AEP,UK,WG,IT,E,Saudi Arabia) ...CERAMIC 100PF 10% 50V
902	*1-533-213-31	HOLDER, FUSE	C054	1-124-902-00	(AEP,UK,WG,IT,E,Saudi Arabia) ...ELECT 0.47MF 20% 50V
903	*1-630-662-11	PC BOARD, POWER	C055	1-162-286-31	(AEP,UK,WG,IT,E,Saudi Arabia) ...CERAMIC 220PF 10% 50V
904	*A-4333-306-A	(AEP,UK,E,Saudi Arabia) ...MOUNTED PCB, PANEL	C056	1-124-927-11	(AEP,UK,WG,IT,E,Saudi Arabia) ...ELECT 4.7MF 20% 50V
	*A-4333-312-A	(WG,IT)...MOUNTED PCB, PANEL	C057	1-130-480-00	(AEP,UK,WG,IT,E,Saudi Arabia) ...MYLAR 0.0056MF 5% 50V
	*A-4333-317-A	(US,Canadian)...MOUNTED PCB, PANEL	C058	1-130-473-00	(AEP,UK,WG,IT,E,Saudi Arabia) ...MYLAR 0.0015MF 5% 50V
905	*1-630-663-11	PC BOARD, VOL	C059	1-124-925-11	(AEP,UK,WG,IT,E,Saudi Arabia) ...ELECT 2.2MF 20% 50V
906	*1-630-664-11	PC BOARD, VOL TERMINAL	C060	1-162-282-31	CERAMIC 100PF 10% 50V
908	*A-4333-305-A	(717,717M:AEP,UK) ...MOUNTED PCB, CONTROL	C061	1-162-282-31	CERAMIC 100PF 10% 50V
	*A-4333-311-A	(717M:WG)...MOUNTED PCB, CONTROL	C101	1-124-925-11	ELECT 2.2MF 20% 50V
	*A-4333-316-A	(717M:US,Canadian) ...MOUNTED PCB, CONTROL	C102	1-123-875-11	ELECT 10MF 20% 50V
	*A-4333-326-A	(818M:WG,IT)...MOUNTED PCB, CONTROL	C103	1-124-499-11	ELECT 1MF 20% 50V
	*A-4333-363-A	(818,818M:AEP,UK) ...MOUNTED PCB, CONTROL	C104	1-124-768-11	(US,Canadian)...ELECT 4.7MF 20% 50V
	*A-4333-389-A	(818M:US)...MOUNTED PCB, CONTROL	C105	1-126-233-11	ELECT 22MF 20% 25V
909	Δ 1-630-659-11	PC BOARD, POWER AMP	C106	1-136-171-00	FILM 0.33MF 5% 50V
910	Δ 1-551-188-XX	(E)...CORD, POWER	C201	1-136-165-00	FILM 0.1MF 5% 50V
	Δ 1-557-577-11	(US,Canadian)...CORD, POWER	C202	1-136-165-00	FILM 0.1MF 5% 50V
911	Δ 1-526-565-00	(E)...AC PLUG ADAPTOR	C203	1-124-563-11	ELECT 2200MF 20% 25V
912	Δ 1-506-401-11	(Saudi Arabia)...ADAPTOR, CONVERSION	C204	1-124-563-11	ELECT 2200MF 20% 25V
913	Δ 1-555-750-00	(AEP,WG,IT,Saudi Arabia)...CORD, POWER	C205	1-136-165-00	FILM 0.1MF 5% 50V
914	Δ 1-556-037-00	(UK)...CORD, POWER	C206	1-124-478-11	ELECT 100MF 20% 25V
BP201	*1-508-830-12	H TYPE BASE POST	C207	1-136-165-00	FILM 0.1MF 5% 50V
BP901	*1-535-139-12	(US,Canadian)...BASE POST 22MM(10MM PICH)	C208	1-136-165-00	FILM 0.1MF 5% 50V
BP904	*1-508-830-12	H TYPE BASE POST	C209	1-124-477-11	ELECT 47MF 20% 16V
C001	1-162-282-31	CERAMIC 100PF 10% 50V	C210	1-124-477-11	ELECT 47MF 20% 16V
C002	1-162-282-31	CERAMIC 100PF 10% 50V	C211	1-136-165-00	FILM 0.1MF 5% 50V
C003	1-162-282-31	(AEP,UK,WG,IT,E,Saudi Arabia) ...CERAMIC 100PF 10% 50V	C212	1-124-477-11	ELECT 47MF 20% 16V
C004	1-124-902-00	(AEP,UK,WG,IT,E,Saudi Arabia) ...ELECT 0.47MF 20% 50V	C220	1-124-477-11	(AEP,UK,WG,IT,E,Saudi Arabia) ...ELECT 47MF 20% 16V
C005	1-162-286-31	(AEP,UK,WG,IT,E,Saudi Arabia) ...CERAMIC 220PF 10% 50V	C221	1-124-477-11	(AEP,UK,WG,IT,E,Saudi Arabia) ...ELECT 47MF 20% 16V
C006	1-124-927-11	(AEP,UK,WG,IT,E,Saudi Arabia) ...ELECT 4.7MF 20% 50V	C222	1-124-477-11	ELECT 47MF 20% 16V
C007	1-130-480-00	(AEP,UK,WG,IT,E,Saudi Arabia) ...MYLAR 0.0056MF 5% 50V	C223	1-124-477-11	ELECT 47MF 20% 16V
C008	1-130-473-00	(AEP,UK,WG,IT,E,Saudi Arabia) ...MYLAR 0.0015MF 5% 50V	C224	1-124-477-11	ELECT 47MF 20% 16V
C009	1-124-925-11	(AEP,UK,WG,IT,E,Saudi Arabia) ...ELECT 2.2MF 20% 50V	C301	1-124-902-00	ELECT 0.47MF 20% 50V
C010	1-162-282-31	CERAMIC 100PF 10% 50V	C302	1-136-163-00	FILM 0.068MF 5% 50V
C011	1-162-282-31	CERAMIC 100PF 10% 50V	C303	1-124-463-00	ELECT 0.1MF 20% 50V
C051	1-162-282-31	CERAMIC 100PF 10% 50V	C304	1-136-156-00	FILM 0.018MF 5% 50V
C052	1-162-282-31	CERAMIC 100PF 10% 50V	C305	1-136-162-00	FILM 0.056MF 5% 50V
			C306	1-130-480-00	MYLAR 0.0056MF 5% 50V

Ref.No.	Part No.	Description						
C307	1-136-155-00	FILM	0.015MF	5%	50V			
C308	1-130-472-00	MYLAR	0.0012MF	5%	50V			
C309	1-130-479-00	MYLAR	0.0047MF	5%	50V			
C310	1-130-467-00	MYLAR	470PF	5%	50V			
C311	1-162-215-31	CERAMIC	47PF	5%	50V			
C312	1-162-282-31	CERAMIC	100PF	10%	50V			
C314	1-136-165-00	FILM	0.1MF	5%	50V			
C315	1-124-499-11	ELECT	1MF	20%	50V			
C316	1-136-165-00	FILM	0.1MF	5%	50V			
C317	1-123-875-11	ELECT	10MF	20%	50V			
C320	1-162-294-31	CERAMIC	0.001MF	10%	50V			
C321	1-124-499-11	ELECT	1MF	20%	50V			
C322	1-162-294-31	CERAMIC	0.001MF	10%	50V			
C323	1-124-902-00	ELECT	0.47MF	20%	50V			
C324	1-161-379-00	CERAMIC	0.01MF	30%	16V			
C325	1-123-875-11	ELECT	10MF	20%	50V			
C351	1-124-902-00	ELECT	0.47MF	20%	50V			
C352	1-136-163-00	FILM	0.068MF	5%	50V			
C353	1-124-463-00	ELECT	0.1MF	20%	50V			
C354	1-136-156-00	FILM	0.018MF	5%	50V			
C355	1-136-162-00	FILM	0.056MF	5%	50V			
C356	1-130-480-00	MYLAR	0.0056MF	5%	50V			
C357	1-136-155-00	FILM	0.015MF	5%	50V			
C358	1-130-472-00	MYLAR	0.0012MF	5%	50V			
C359	1-130-479-00	MYLAR	0.0047MF	5%	50V			
C360	1-130-467-00	MYLAR	470PF	5%	50V			
C361	1-162-215-31	CERAMIC	47PF	5%	50V			
C362	1-162-282-31	CERAMIC	100PF	10%	50V			
C364	1-136-165-00	FILM	0.1MF	5%	50V			
C365	1-124-499-11	ELECT	1MF	20%	50V			
C366	1-136-165-00	FILM	0.1MF	5%	50V			
C367	1-123-875-11	ELECT	10MF	20%	50V			
C401	1-161-379-00	CERAMIC	0.01MF	30%	16V			
C402	1-126-233-11	ELECT	22MF	20%	50V			
C403	1-126-233-11	ELECT	22MF	20%	50V			
C404	1-161-374-11	CERAMIC	0.0015MF	20%	16V			
C405	1-161-327-00	CERAMIC	0.0033MF	20%	16V			
C406	1-161-327-00	CERAMIC	0.0033MF	20%	16V			
C407	1-124-257-00	ELECT	2.2MF	20%	50V			
C408	1-161-327-00	CERAMIC	0.0033MF	20%	16V			
C409	1-161-327-00	CERAMIC	0.0033MF	20%	16V			
C410	1-124-257-00	ELECT	2.2MF	20%	50V			
C411	1-161-379-00	CERAMIC	0.01MF	30%	16V			
C412	1-161-379-00	CERAMIC	0.01MF	30%	16V			
C413	1-124-257-00	ELECT	2.2MF	20%	50V			
C414	1-124-465-00	ELECT	0.47MF	20%	50V			
C415	1-124-257-00	ELECT	2.2MF	20%	50V			
C416	1-161-327-00	CERAMIC	0.0033MF	20%	16V			
C417	1-124-257-00	ELECT	2.2MF	20%	50V			
C418	1-124-257-00	ELECT	2.2MF	20%	50V			
C419	1-161-379-00	CERAMIC	0.01MF	30%	16V			
C420	1-162-282-31	CERAMIC	100PF	10%	50V			
C421	1-123-875-11	ELECT	10MF	20%	50V			
C422	1-124-477-11	ELECT	47MF	20%	16V			
C425	1-161-379-00	CERAMIC	0.01MF	30%	16V			
C426	1-124-477-11	ELECT	47MF	20%	16V			
C427	1-123-875-11	ELECT	10MF	20%	50V			
C428	1-123-875-11	ELECT	10MF	20%	50V			
C429	1-124-925-11	ELECT	2.2MF	20%	50V			
C801	1-124-499-11	ELECT	1MF	20%	50V			
C802	1-162-288-31	CERAMIC	330PF	10%	50V			
C803	1-162-282-31	CERAMIC	100PF	10%	50V			
C804	1-124-122-11	ELECT	100MF	20%	35V			
C805	1-124-910-11	ELECT	47MF	20%	50V			
C806	1-136-161-00	(US,Canadian,E,Saudi Arabia)						
		...FILM	0.047MF	5%	50V			
C806	1-136-165-00	(AEP,UK,WG,IT)...FILM	0.1MF	5%	50V			
C807	1-136-165-00	(AEP,UK,WG,IT)...FILM	0.1MF	5%	50V			
C821	1-124-122-11	ELECT	100MF	20%	50V			
C823	1-123-875-11	ELECT	10MF	20%	50V			
C824	1-126-176-11	ELECT	220MF	20%	10V			
C825	1-126-233-11	ELECT	22MF	20%	25V			
C826	1-126-176-11	ELECT	220MF	20%	10V			
C827	1-161-379-00	CERAMIC	0.01MF	30%	16V			
C828	1-161-494-00	CERAMIC	0.022MF		25V			
C829	1-124-477-11	ELECT	47MF	20%	16V			
C830	1-124-927-11	ELECT	4.7MF	20%	50V			
C831	1-124-463-00	ELECT	0.1MF	20%	50V			
C832	1-123-875-11	ELECT	10MF	20%	50V			
C833A	1-124-927-11	ELECT	4.7MF	20%	50V			
C833B	1-123-875-11	ELECT	10MF	20%	50V			
C834	1-161-379-00	CERAMIC	0.01MF	30%	16V			
C835	1-123-875-11	ELECT	10MF	20%	50V			
C851	1-124-499-11	ELECT	1MF	20%	50V			
C852	1-162-288-31	CERAMIC	330PF	10%	50V			
C853	1-162-282-31	CERAMIC	100PF	10%	50V			
C854	1-124-122-11	ELECT	100MF	20%	35V			
C855	1-124-910-11	ELECT	47MF	20%	50V			
C856	1-136-161-00	(US,Canadian,E,Saudi Arabia)						
		...FILM	0.047MF	5%	50V			
C856	1-136-165-00	(AEP,UK,WG,IT)...FILM	0.1MF	5%	50V			
C857	1-136-165-00	(AEP,UK,WG,IT)...FILM	0.1MF	5%	50V			
C901	1-136-171-00	FILM	0.33MF	5%	50V			
C902	1-136-171-00	FILM	0.33MF	5%	50V			
C903	1-126-224-11	ELECT	4700MF	20%	42V			
C904	1-126-224-11	ELECT	4700MF	20%	42V			
C905	△.1-161-742-00	CERAMIC	0.0022MF	20%	400V			
C906	1-136-165-00	FILM	0.1MF	5%	50V			
C907	1-124-912-11	ELECT	330MF	20%	50V			
C908	1-124-912-11	ELECT	330MF	20%	50V			
C909	1-124-479-11	ELECT	330MF	20%	25V			
C910	1-161-379-00	CERAMIC	0.01MF	30%	16V			
C911	1-136-165-00	FILM	0.1MF	5%	50V			
C912	1-124-910-11	ELECT	47MF	20%	50V			
C913	1-124-477-11	ELECT	47MF	20%	16V			
C914	1-136-165-00	(WG,IT)...FILM	0.1MF	5%	50V			
C915	1-136-165-00	(WG,IT)...FILM	0.1MF	5%	50V			
CN001	1-564-610-41	CONNECTOR, BOARD TO BOARD 1P						
CN002	1-506-979-31	CONNECTOR, BOARD TO BOARD 13P						
CNJ001*1	566-858-11	SOCKET, CONNECTOR 11P (FOR ST)						
CNJ003*1	565-291-11	SOCKET, CONNECTOR 13P (FOR TC)						
CNJ005*1	566-925-11	SOCKET, CONNECTOR 8P						
CNJ006*1	566-926-11	SOCKET, CONNECTOR 10P						
CNJ008*1	566-926-11	SOCKET, CONNECTOR 10P						

Note:

The components identified by mark Δ or dotted line with mark Δ are critical for safety. Replace only with part number specified.

Note:

Les composants identifiés par une marque Δ sont critiques pour la sécurité. Ne les remplacer que par une pièce portant le numéro spécifié.

Ref.No.	Part No.	Description
CNP002	1-564-980-11	PIN, CONNECTOR 4P (FOR CD)
CNP005*1	-566-923-11	PLUG, CONNECTOR 8P
CNP006*1	-566-924-11	PLUG, CONNECTOR 10P
CNP008*1	-566-924-11	PLUG, CONNECTOR 10P
CNP601*1	-564-704-11	PIN, CONNECTOR (SMALL TYPE) 2P
CNP602*1	-564-521-11	PLUG, CONNECTOR 6P
CNP801*1	-564-338-61	PIN, CONNECTOR 4P
CNP802*1	-564-339-00	PIN, CONNECTOR 5P
CNP803*1	-564-338-00	PIN, CONNECTOR 4P
CNP805*1	-564-496-11	PIN, CONNECTOR 3P
CNP901*1	-564-104-00	PIN, CONNECTOR 3P
CNP902*1	-564-915-11	(E,Saudi Arabia)...PIN, CONNECTOR 7P
CP401	1-233-026-11	COMPOSITION CIRCUIT BLOCK (100KX12)
CP402	1-233-140-11	COMPOSITION CIRCUIT BLOCK (100KX8)
D101	8-719-000-26	DIODE US1060M
D201	8-719-200-77	DIODE 10E2N
D202	8-719-200-77	DIODE 10E2N
D203	8-719-200-77	DIODE 10E2N
D204	8-719-200-77	DIODE 10E2N
D401	8-719-000-26	DIODE US1060M
D402	8-719-933-68	DIODE HZS11B-3L
D403	8-719-303-13	DIODE SEL1210W
D404	8-719-303-13	DIODE SEL1210W
D405	8-719-303-13	DIODE SEL1210W
D406	8-719-303-13	DIODE SEL1210W
D407	8-719-303-13	DIODE SEL1210W
D408	8-719-303-59	DIODE SEL1910W
D409	8-719-303-59	DIODE SEL1910W
D410	8-719-010-29	DIODE UZ-4.3BSB
D411	8-719-000-26	DIODE US1060M
D412	8-719-000-26	DIODE US1060M
D413	8-719-000-26	DIODE US1060M
D414	8-719-000-26	DIODE US1060M
D415	8-719-000-26	DIODE US1060M
D416	8-719-000-26	DIODE US1060M
D417	8-719-000-26	DIODE US1060M
D418	8-719-000-26	DIODE US1060M
D419	8-719-000-26	DIODE US1060M
D420	8-719-000-26	DIODE US1060M
D421	8-719-000-26	DIODE US1060M
D422	8-719-303-33	DIODE SEL4214W
D423	8-719-000-90	DIODE UZL-7M3
D801	8-719-000-26	DIODE US1060M
D821	8-719-000-26	DIODE US1060M
D822	8-719-000-26	DIODE US1060M
D851	8-719-000-26	DIODE US1060M
D901	8-719-302-38	(US,Canadian,E,Saudi Arabia,818M:AEP,UK,WG,IT)...DIODE RBV-602-01
D901	8-719-302-36	(717M:AEP,UK,WG)...DIODE RBV-402-01
D902	8-719-000-26	DIODE US1060M
D903	8-719-000-26	DIODE US1060M
D904	8-719-200-77	DIODE 10E2N
D905	8-719-200-77	DIODE 10E2N
D906	8-719-200-77	DIODE 10E2N
D907	8-719-000-26	DIODE US1060M
D911	8-719-014-23	DIODE UZP-3.3BB

Note:
The components identified by mark Δ or dotted line with mark Δ are critical for safety. Replace only with part number specified.

Note:
Les composants identifiés par une marque Δ sont critiques pour la sécurité. Ne les remplacer que par une pièce portant le numéro spécifié.

Ref.No.	Part No.	Description
F201	Δ .1-532-783-21	(US,Canadian)...FUSE, MICRO (SECONDARY)5A
F202	Δ .1-532-783-21	(US,Canadian)...FUSE, MICRO (SECONDARY)5A
F203	Δ .1-532-780-21	(818M:US)...FUSE, MICRO(SECONDARY)5A
F901	Δ .1-532-285-00	(E,Saudi Arabia,818M:AEP,UK,WG,IT) ...FUSE, TIME-LAG (1.25A)
F901	Δ .1-532-078-00	(717M:AEP,UK,WG)...FUSE, TIME-LAG (1A)
F901	Δ .1-532-742-11	(717M:US,Canadian) ...FUSE, GLASS TUBE (1.6A)
F901	Δ .1-532-743-11	(818M:US).....FUSE, GLASS TUBE (2A)
F902	Δ .1-532-285-00	(E,Saudi Arabia) ...FUSE, TIME-LAG (1.25A)
FL401	1-519-516-11	INDICATOR TUBE, FLUORESCENT
IC001	8-759-600-02	(AEP,UK,WG,IT,E,Saudi Arabia) ...IC M5218L
IC002	8-759-240-52	IC TC4052BP
IC003	8-759-600-02	IC M5218L
IC101	8-759-632-01	IC M50725-116SP
IC201	8-759-604-33	IC M5F7812
IC202	8-759-604-30	IC M5F7808
IC203	8-759-604-30	IC M5F7908
IC301	8-759-602-04	IC M5226P
IC302	8-759-601-43	IC M4066BP
IC303	8-759-600-02	IC M5218L
IC351	8-759-602-04	IC M5226P
IC401	8-759-820-07	IC LC7566
IC402	8-759-600-02	IC M5218L
IC403	8-759-600-02	IC M5218L
IC404	8-759-820-62	IC LB1639
IC801	8-749-900-96	(717M).....IC STK4142MK2
IC801	8-749-941-52	(717,818,818M)...IC STK415211
IC802	8-759-111-68	IC UPC1237HA
IC901	8-759-604-84	IC M5F7806
IC902	8-759-604-93	IC M5F7924
Δ ICP201	1-532-846-21	(AEP,UK,WG,IT,E,Saudi Arabia)..LINK, IC
Δ ICP202	1-532-846-21	(AEP,UK,WG,IT,E,Saudi Arabia)..LINK, IC
J001	1-565-258-11	JACK, PIN 4P (CD/PHONO or AUX)
J901	1-562-981-21	JACK (MIX MIC)
J902	1-562-837-11	JACK (HEADPHONES)
L101	1-410-521-11	INDUCTOR 100UH
L102	1-410-521-11	INDUCTOR 100UH
L401	1-410-521-11	INDUCTOR 100UH
L801	*1-420-872-00	COIL, AIR CORE
L851	*1-420-872-00	COIL, AIR CORE
PT901	Δ .1-449-561-11	(E,Saudi Arabia)....TRANSFORMER, POWER
PT901	Δ .1-449-562-11	(717M:UK).....TRANSFORMER, POWER
PT901	Δ .1-449-563-11	(717M:AEP,UK).....TRANSFORMER, POWER
PT901	Δ .1-449-564-11	(717M:US,Canadian)..TRANSFORMER, POWER
PT901	Δ .1-449-568-11	(818M:UK).....TRANSFORMER, POWER
PT901	Δ .1-449-569-11	(818M:AEP,WG,IT)....TRANSFORMER, POWER
PT901	Δ .1-449-570-11	(818M:US).....TRANSFORMER, POWER
PT902	Δ .1-449-565-11	(E,Saudi Arabia)...TRANSFORMER, POWER
PT902	Δ .1-449-566-11	(AEP,UK,WG,IT)....TRANSFORMER, POWER
PT902	Δ .1-449-567-11	(US,Canadian).....TRANSFORMER, POWER
Q101	8-729-119-78	TRANSISTOR 2SC2785
Q102	8-729-806-30	TRANSISTOR 2SC4048
Q301	8-729-119-78	TRANSISTOR 2SC2785

Ref.No.	Part No.	Description	Ref.No.	Part No.	Description			
Q302	8-729-119-78	TRANSISTOR 2SC2785	R067	1-249-423-11	CARBON	3.3K	5%	1/4W
Q303	8-729-119-78	TRANSISTOR 2SC2785	R068	1-249-435-11	CARBON	33K	5%	1/4W
Q351	8-729-119-78	TRANSISTOR 2SC2785	R069	1-249-413-11	CARBON	470	5%	1/4W
Q353	8-729-119-78	TRANSISTOR 2SC2785	R070	1-249-405-11	CARBON	100	5%	1/4W
Q401	8-729-900-80	TRANSISTOR DTC114ES	R101	1-249-417-11	CARBON	1K	5%	1/4W
Q402	8-729-806-34	TRANSISTOR 2SC3400	R102	1-249-423-11	CARBON	3.3K	5%	1/4W
Q403	8-729-900-80	TRANSISTOR DTC114ES	R103	1-249-417-11	CARBON	1K	5%	1/4W
Q404	8-729-119-78	TRANSISTOR 2SC2785	R104	1-249-441-11	CARBON	100K	5%	1/4W
Q406	8-729-800-93	TRANSISTOR 2SD1387	R105	1-249-417-11	CARBON	1K	5%	1/4W
Q801	8-729-108-05	TRANSISTOR 2SC1841-PA	R106	1-249-429-11	CARBON	10K	5%	1/4W
Q802	8-729-173-38	TRANSISTOR 2SA733	R107	1-249-429-11	CARBON	10K	5%	1/4W
Q901	8-729-801-93	TRANSISTOR 2SD1387	R108	1-249-441-11	CARBON	100K	5%	1/4W
R001	1-249-417-11	CARBON	1K	5%	1/4W			
R002	1-249-423-11	CARBON	3.3K	5%	1/4W			
R003	1-249-429-11	CARBON	10K	5%	1/4W			
R004	1-249-417-11	CARBON	1K	5%	1/4W			
R005	1-249-417-11	(AEP,UK,WG,IT,E,Saudi Arabia) ...CARBON 1K 5% 1/4W						
R006	1-249-438-11	(AEP,UK,WG,IT,E,Saudi Arabia) ...CARBON 56K 5% 1/4W						
R007	1-249-417-11	(AEP,UK,WG,IT,E,Saudi Arabia) ...CARBON 1K 5% 1/4W						
R008	1-247-897-11	(AEP,UK,WG,IT,E,Saudi Arabia) ...CARBON 560K 5% 1/4W						
R009	1-249-437-11	(AEP,UK,WG,IT,E,Saudi Arabia) ...CARBON 47K 5% 1/4W						
R010	1-249-430-11	(AEP,UK,WG,IT,E,Saudi Arabia) ...CARBON 12K 5% 1/4W						
R010	1-249-428-11	(US,Canadian)...CARBON 8.2K 5% 1/4W						
R011	1-249-429-11	CARBON	10K	5%	1/4W			
R012	1-249-426-11	CARBON	5.6K	5%	1/4W			
R013	1-249-429-11	CARBON	10K	5%	1/4W			
R014	1-249-426-11	CARBON	5.6K	5%	1/4W			
R015	1-249-429-11	CARBON	10K	5%	1/4W			
R016	1-249-428-11	CARBON	8.2K	5%	1/4W			
R017	1-249-423-11	CARBON	3.3K	5%	1/4W			
R018	1-249-435-11	CARBON	33K	5%	1/4W			
R019	1-249-413-11	CARBON	470	5%	1/4W			
R020	1-249-405-11	CARBON	100	5%	1/4W			
R051	1-249-417-11	CARBON	1K	5%	1/4W			
R052	1-249-423-11	CARBON	3.3K	5%	1/4W			
R053	1-249-429-11	CARBON	10K	5%	1/4W			
R054	1-249-417-11	CARBON	1K	5%	1/4W			
R055	1-249-417-11	(AEP,UK,WG,IT,E,Saudi Arabia) ...CARBON 1K 5% 1/4W						
R056	1-249-438-11	(AEP,UK,WG,IT,E,Saudi Arabia) ...CARBON 56K 1% 1/4W						
R057	1-249-417-11	(AEP,UK,WG,IT,E,Saudi Arabia) ...CARBON 1K 5% 1/4W						
R058	1-247-897-11	(AEP,UK,WG,IT,E,Saudi Arabia) ...CARBON 560K 5% 1/4W						
R059	1-249-437-11	(AEP,UK,WG,IT,E,Saudi Arabia) ...CARBON 47K 5% 1/4W						
R060	1-249-430-11	(AEP,UK,WG,IT,E,Saudi Arabia) ...CARBON 12K 5% 1/4W						
R060	1-249-428-11	(US,Canadian)...CARBON 8.2K 5% 1/4W						
R061	1-249-429-11	CARBON	10K	5%	1/4W			
R062	1-249-426-11	CARBON	5.6K	5%	1/4W			
R063	1-249-429-11	CARBON	10K	5%	1/4W			
R064	1-249-426-11	CARBON	5.6K	5%	1/4W			
R065	1-249-429-11	CARBON	10K	5%	1/4W			
R066	1-249-428-11	CARBON	8.2K	5%	1/4W			
R112	1-249-417-11	CARBON	1K	5%	1/4W			
R113	1-249-405-11	CARBON	100	5%	1/4W			
R114	1-249-405-11	CARBON	100	5%	1/4W			
R115	1-249-405-11	CARBON	100	5%	1/4W			
R116	1-249-405-11	CARBON	100	5%	1/4W			
R117	1-249-405-11	CARBON	100	5%	1/4W			
R118	1-249-405-11	CARBON	100	5%	1/4W			
R119	1-249-437-11	CARBON	47K	5%	1/4W			
R120	1-249-405-11	CARBON	100	5%	1/4W			
R121	1-249-417-11	CARBON	1K	5%	1/4W			
R122	1-249-405-11	CARBON	100	5%	1/4W			
R123	1-249-393-11	CARBON	10	5%	1/4W			
R124	1-249-393-11	(US,Canadian)...CARBON	10	5%	1/4W			
R125	1-247-903-00	CARBON	1M	5%	1/4W			
R126	1-249-421-11	CARBON	2.2K	5%	1/4W			
R127	1-249-429-11	CARBON	10K	5%	1/4W			
R128	1-249-401-11	CARBON	47	5%	1/4W			
R129	1-249-429-11	CARBON	10K	5%	1/4W			
R130	△,1-217-469-00	(818M:US)...FUSIBLE	1	5%	1W	F		
R201	△,1-217-481-00	FUSIBLE	10	5%	1W	F		
R202	△,1-217-489-00	FUSIBLE	47	5%	1W	F		
R301	1-249-425-11	CARBON	4.7K	5%	1/4W			
R302	1-249-413-11	CARBON	470	5%	1/4W			
R303	1-249-441-11	CARBON	100K	5%	1/4W			
R304	1-249-437-11	CARBON	47K	5%	1/4W			
R305	1-249-432-11	CARBON	18K	5%	1/4W			
R306	1-249-431-11	CARBON	15K	5%	1/4W			
R307	1-249-429-11	CARBON	10K	5%	1/4W			
R308	1-247-891-00	CARBON	330K	5%	1/4W			
R309	1-249-421-11	CARBON	2.2K	5%	1/4W			
R310	1-249-425-11	CARBON	4.7K	5%	1/4W			
R311	1-249-429-11	CARBON	10K	5%	1/4W			
R320	1-249-414-11	CARBON	560	5%	1/4W			
R321	1-249-429-11	CARBON	10K	5%	1/4W			
R322	1-249-415-11	CARBON	680	5%	1/4W			
R323	1-249-441-11	CARBON	100K	5%	1/4W			
R324	1-249-434-11	CARBON	27K	5%	1/4W			
R325	1-249-422-11	CARBON	2.7K	5%	1/4W			
R326	1-249-429-11	CARBON	10K	5%	1/4W			
R351	1-249-425-11	CARBON	4.7K	5%	1/4W			
R352	1-249-413-11	CARBON	470	5%	1/4W			
R353	1-249-441-11	CARBON	100K	5%	1/4W			

Note:
The components identified by mark Δ or dotted line with mark Δ are critical for safety. Replace only with part number specified.

Note:
Les composants identifiés par une marque Δ sont critiques pour la sécurité. Ne les remplacer que par une pièce portant le numéro spécifié.

Ref.No.	Part No.	Description			
R354	1-249-437-11	CARBON	47K	5%	1/4W
R355	1-249-432-11	CARBON	18K	5%	1/4W
R356	1-249-431-11	CARBON	15K	5%	1/4W
R357	1-249-429-11	CARBON	10K	5%	1/4W
R358	1-247-891-00	CARBON	330K	5%	1/4W
R359	1-249-421-11	CARBON	2.2K	5%	1/4W
R360	1-249-425-11	CARBON	4.7K	5%	1/4W
R401	1-249-425-11	CARBON	4.7K	5%	1/4W
R402	1-249-415-11	CARBON	680	5%	1/4W
R403	1-249-416-11	CARBON	820	5%	1/4W
R404	1-249-413-11	CARBON	470	5%	1/4W
R405	1-249-408-11	CARBON	180	5%	1/4W
R406	1-249-414-11	CARBON	560	5%	1/4W
R407	1-249-429-11	CARBON	10K	5%	1/4W
R408	1-249-413-11	CARBON	470	5%	1/4W
R409	1-249-415-11	(US,Canadian)...CARBON	680	5%	1/4W
R409	1-249-420-11	(AEP,UK,WG,IT,E,Saudi Arabia) ...CARBON	1.8K	5%	1/4W
R410	1-249-419-11	(AEP,UK,WG,IT,E,Saudi Arabia) ...CARBON	1.5K	5%	1/4W
R410	1-249-422-11	(US,Canadian)...CARBON	2.7K	5%	1/4W
R411	1-249-421-11	CARBON	2.2K	5%	1/4W
R412	1-249-425-11	CARBON	4.7K	5%	1/4W
R413	1-249-430-11	CARBON	12K	5%	1/4W
R414	1-249-441-11	CARBON	100K	5%	1/4W
R415	1-249-441-11	CARBON	100K	5%	1/4W
R416	1-249-432-11	CARBON	18K	5%	1/4W
R417	1-249-429-11	CARBON	10K	5%	1/4W
R418	1-249-434-11	CARBON	27K	5%	1/4W
R419	1-249-425-11	CARBON	4.7K	5%	1/4W
R420	1-249-436-11	CARBON	39K	5%	1/4W
R421	1-249-441-11	CARBON	100K	5%	1/4W
R422	1-249-441-11	CARBON	100K	5%	1/4W
R423	1-249-432-11	CARBON	18K	5%	1/4W
R424	1-247-883-00	CARBON	150K	5%	1/4W
R425	1-249-441-11	CARBON	100K	5%	1/4W
R426	1-249-440-11	CARBON	82K	5%	1/4W
R427	1-249-431-11	CARBON	15K	5%	1/4W
R428	1-247-881-00	CARBON	120K	5%	1/4W
R429	1-249-441-11	CARBON	100K	5%	1/4W
R430	1-249-426-11	CARBON	5.6K	5%	1/4W
R431	1-249-441-11	CARBON	100K	5%	1/4W
R432	1-249-427-11	CARBON	6.8K	5%	1/4W
R433	1-249-441-11	CARBON	100K	5%	1/4W
R434	1-249-416-11	CARBON	820	5%	1/4W
R435	1-249-425-11	CARBON	4.7K	5%	1/4W
R436	1-249-441-11	CARBON	100K	5%	1/4W
R437	1-247-903-00	CARBON	1M	5%	1/4W
R438	1-249-408-11	CARBON	180	5%	1/4W
R439	1-249-429-11	CARBON	10K	5%	1/4W
R440	1-249-429-11	CARBON	10K	5%	1/4W
R441	1-249-429-11	CARBON	10K	5%	1/4W
R442	1-249-415-11	CARBON	680	5%	1/4W
R443	1-249-422-11	CARBON	2.7K	5%	1/4W
R444	1-249-429-11	CARBON	10K	5%	1/4W
R445	1-249-429-11	CARBON	10K	5%	1/4W
R447	1-249-417-11	CARBON	1K	5%	1/4W

Ref.No.	Part No.	Description			
R448	1-247-885-00	CARBON	180K	5%	1/4W
R449	1-249-385-11	CARBON	2.2	5%	1/4W
R450	1-249-405-11	CARBON	100	5%	1/4W
R451	1-249-441-11	CARBON	100K	5%	1/4W
R452	1-249-441-11	CARBON	100K	5%	1/4W
R453	1-249-419-11	CARBON	1.5K	5%	1/4W
R456	1-249-417-11	CARBON	1K	5%	1/4W
R457	1-249-417-11	CARBON	1K	5%	1/4W
R458	1-249-421-11	CARBON	2.2K	5%	1/4W
R459	1-249-437-11	CARBON	47K	5%	1/4W
R460	1-249-437-11	CARBON	47K	5%	1/4W
R801	1-249-417-11	CARBON	1K	5%	1/4W
R802	1-249-438-11	CARBON	56K	5%	1/4W
R803	1-249-438-11	CARBON	56K	5%	1/4W
R804	1-249-414-11	CARBON	560	5%	1/4W
R805	1-249-438-11	CARBON	56K	5%	1/4W
R806	1-247-756-11	CARBON	2.2K	5%	1/2W
R807	1-247-756-11	CARBON	2.2K	5%	1/2W
R808	1-249-429-11	CARBON	10K	5%	1/4W
R809	△.1-247-727-11	CARBON	10	5%	1/2W F
R810	1-249-438-11	CARBON	56K	5%	1/4W
R811	1-217-151-00	METAL PLATE	0.22	10%	2W
R821	△.1-212-881-11	FUSIBLE	100	5%	1/4W F
R822	1-247-752-11	CARBON	1K	5%	1/2W
R823	1-247-752-11	CARBON	1K	5%	1/2W
R824	△.1-212-881-11	FUSIBLE	100	5%	1/4W F
R825	1-249-441-11	CARBON	100K	5%	1/4W
R826	1-249-429-11	CARBON	10K	5%	1/4W
R827	1-249-433-11	CARBON	22K	5%	1/4W
R828	1-249-433-11	CARBON	22K	5%	1/4W
R829	1-249-433-11	CARBON	22K	5%	1/4W
R830	△.1-247-741-11	(717M).....CARBON	150	5%	1/2W F
R830	△.1-247-744-11	(717,818,818M)...CARBON	270	5%	1/2W F
R831	1-249-439-11	CARBON	68K	5%	1/4W
R832	1-249-430-11	CARBON	12K	5%	1/4W
R833	1-249-413-11	CARBON	470	5%	1/4W
R834	1-249-429-11	CARBON	10K	5%	1/4W
R835	1-249-414-11	CARBON	560	5%	1/4W
R836	1-249-441-11	CARBON	100K	5%	1/4W
R837	1-247-903-00	CARBON	1M	5%	1/4W
R851	1-249-417-11	CARBON	1K	5%	1/4W
R852	1-249-438-11	CARBON	56K	5%	1/4W
R853	1-249-438-11	CARBON	56K	5%	1/4W
R854	1-249-414-11	CARBON	560	5%	1/4W
R855	1-249-438-11	CARBON	56K	5%	1/4W
R856	1-247-756-11	CARBON	2.2K	5%	1/2W
R857	1-247-756-11	CARBON	2.2K	5%	1/2W
R858	1-249-429-11	CARBON	10K	5%	1/4W
R859	△.1-247-727-11	CARBON	10	5%	1/2W F
R860	1-249-437-11	CARBON	47K	5%	1/4W
R861	1-217-151-00	METAL PLATE	0.22	10%	2W
R862	△.1-212-881-11	FUSIBLE	100	5%	1/4W F
R901	1-249-427-11	(717M).....CARBON	6.8K	5%	1/4W
R901	1-249-429-11	(717,818,818M)...CARBON	10K	5%	1/4W
R902	1-249-425-11	CARBON	4.7K	5%	1/4W
R904	△.1-247-741-11	CARBON	150	5%	1/2W F
R905	1-249-429-11	CARBON	10K	5%	1/4W

Note:
The components identified by mark Δ or dotted line with mark Δ are critical for safety. Replace only with part number specified.

Note:
Les composants identifiés par une marque Δ sont critiques pour la sécurité. Ne les remplacer que par une pièce portant le numéro spécifié.

Ref.No.	Part No.	Description
R906	1-249-429-11	CARBON 10K 5% 1/4W
R907	1-249-432-11	CARBON 18K 5% 1/4W
R908	△.1-247-750-11	(717M).....CARBON 680 5% 1/2W F
R908	△.1-247-751-11	(717,818,818M)...CARBON 820 5% 1/2W F
R909	△.1-247-750-11	(717M).....CARBON 680 5% 1/2W F
R909	△.1-247-751-11	(717,818,818M)...CARBON 820 5% 1/2W F
R910	△.1-247-727-11	(WG,IT).....CARBON 10 5% 1/2W F
R911	△.1-247-727-11	(WG,IT).....CARBON 10 5% 1/2W F
R912	△.1-202-725-00	(US,Canadian)...SOLID 3.3M 10% 1/2W
RV301	1-238-457-11	RES, VAR, CARBON 250K/250K (100Hz)
RV302	1-238-457-11	RES, VAR, CARBON 250K/250K (400Hz)
RV303	1-238-457-11	RES, VAR, CARBON 250K/250K (1kHz)
RV304	1-238-457-11	RES, VAR, CARBON 250K/250K (4kHz)
RV305	1-238-457-11	RES, VAR, CARBON 250K/250K (12kHz)
RV306	1-238-491-11	RES, VAR, CARBON 500K/500K (DBFB LEVEL) (SAT LEVEL)
RV307	1-238-459-11	RES, VAR, CARBON 100K (BALANCE)
RV308	1-238-458-11	RES, VAR, CARBON 50K (MIC LEVEL)
RV309	1-237-884-11	RES, VAR, CARBON 100K/100K (VOLUME)
RY801	1-515-503-00	RELAY
RY901	1-515-516-00	RELAY
S401	1-554-303-21	SWITCH, KEY BOARD (POWER)
S402	1-554-303-21	SWITCH, KEY BOARD (DBFB/SAT)
S403	1-554-303-21	SWITCH, KEY BOARD (PHONO/AUX)
S404	1-554-303-21	SWITCH, KEY BOARD (TUNER)
S405	1-554-303-21	SWITCH, KEY BOARD (CD)
S406	1-554-303-21	SWITCH, KEY BOARD (TAPE)
S407	1-554-303-21	SWITCH, KEY BOARD (EQUALIZATION)
S901	△.1-571-437-11	(E,Saudi Arabia)...SWITCH, POWER VOLTAGE CHANGE (VOLTAGE SELECTOR)
TB901	1-536-705-00	TERMINAL BOARD (SP)(SPEAKER)
X101	1-577-358-21	VIBRATOR, CERAMIC 4MHz

Note:
The components identified by mark △ or dotted line with mark △ are critical for safety. Replace only with part number specified.

Note:
Les composants identifiés par une marque △ sont critiques pour la sécurité. Ne les remplacer que par une pièce portant le numéro spécifié.