

# TA-8650

1340  
US Model  
UK Model  
AEP Model  
E Model



## INTEGRATED STEREO AMPLIFIER

### SPECIFICATIONS

#### GENERAL

**System:** Power Amplifier Section  
Direct-coupling V-FET pure complementary symmetry circuit  
Preamplifier Section  
Direct-coupling module unit amp

**Power requirements:** 120V ac, 60 Hz (USA Model)  
100, 120, 220 or 240V ac adjustable,  
50/60 Hz (AEP, UK, E Model)

**Power consumption:** 260 watts (USA Model)  
800 watts (AEP, E Model)  
600 watts (UK Model)

**Ac outlets:** 2 switched 200 watts, 1 unswitched  
400 watts (USA, E Model)

**Dimensions:** 440 (w) x 170 (h) x 425 (d) mm  
17<sup>3</sup>/<sub>8</sub> (w) x 6<sup>3</sup>/<sub>4</sub> (h) x 16<sup>3</sup>/<sub>4</sub> (d) inches

**Weight:** 20.8 kg (46 lb), net  
24.5 kg (54 lb), in shipping carton

**Frequency response:** 5 Hz – 100 kHz  $\pm 0$ / $-1.5$  dB at 1 watt output  
20 Hz – 20 kHz  $\pm 0.1$  dB at rated output

**Residual noise:** Less than 1  $\mu$  watt  
**S/N:** More than 100 dB (network A, short-circuited)

**Damping factor:** More than 200/8 ohms (at 1 kHz, Speaker DIRECT)

**Inputs:** POWER AMP INPUT; sensitivity 1 volt (for rated output), impedance 50 kohms

**Outputs:** SPEAKER terminals – A, B, DIRECT; accept 4 ohms or more speakers.  
HEADPHONE jack; accepts low and high-impedance stereo headphones

#### POWER AMPLIFIER SECTION

**Continuous RMS power output:** At 20 Hz – 20 kHz  
(less than 0.1% THD, both channels driven simultaneously)  
80 watts per channel (8 ohms)

**Power bandwidth:** 5 Hz – 50 kHz (IHF)

**Harmonic distortion:** Less than 0.05% at 1 watt output  
(20 Hz – 20 kHz) Less than 0.1% at rated output

**IM distortion:** Less than 0.05% at 1 watt output  
(60 Hz : 7 kHz = 4 : 1) Less than 0.1% at rated output

#### PREAMPLIFIER SECTION

**Harmonic distortion:** Less than 0.03% at rated output, 1 kHz

**IM distortion:** Less than 0.05% at rated output  
(60 Hz : 7 kHz = 4 : 1)

– Continued on page 2 –

# SONY<sup>®</sup>

## SERVICE MANUAL

1340

**Frequency response:** PHONO 1, 2 RIAA equalization  $\pm 0.2$  dB  
 MIC 20 Hz – 20 kHz  $\begin{matrix} +0 \\ -2.5 \end{matrix}$  dB  
 TUNER  
 AUX 1, 2, 3  
 TAPE 1, 2  
 EXT ADPT (INPUT) } 10 Hz – 100 kHz  $\begin{matrix} +0 \\ -2 \end{matrix}$  dB

**Filters:** LOW 12 dB/octave attenuation below 10 Hz or 40 Hz  
 HIGH 12 dB/octave attenuation above 9 kHz or 20 kHz

**Tone controls:** BASS control  
 $\pm 10$  dB at 50 Hz (TURNOVER  
 FREQ 250 Hz)  
 $\pm 10$  dB at 100 Hz (TURNOVER  
 FREQ 500 Hz)  
 TREBLE control  
 $\pm 10$  dB at 10 kHz (TURNOVER  
 FREQ 2.5 kHz)  
 $\pm 10$  dB at 20 kHz (TURNOVER  
 FREQ 5 kHz)

**Acoustic compensator:** LOW 1 +10 dB at 20 Hz  
 +6 dB at 50 Hz  
 +3 dB at 100 Hz  
 LOW 2 +11 dB at 20 Hz  
 +9 dB at 50 Hz  
 +6 dB at 100 Hz  
 PRESENCE +3 dB at 1 kHz  
 LOUDNESS +10 dB at 50 Hz  
 +3 dB at 10 kHz

**Inputs:**

Inputs	Sensitivity*1	Maximum input capability*2	Impedance	S/N (weighting network, input level)
PHONO 1	2.5 mV	175 mV	50 k $\Omega$	70 dB (A, 2.5 mV)
PHONO 2 L			50 k $\Omega$ /100 k $\Omega$	
H	4.5 mV	310 mV		75 dB (A, 4.5 mV)
HEAD AMP	0.1 mV	7 mV	30 $\Omega$	55 dB (A, 0.1 mV)
MIC	0.2 mV	2 V	50 k $\Omega$	40 dB (B, 0.2 mV)
TUNER	150 mV	—	100 k $\Omega$	85 dB (A, 150 mV)
AUX 1, 2, 3				
TAPE 1, 2				
EXT ADPT				

\*1 The sensitivities of AUX 1, TAPE 1, TAPE 2 and MIC are adjustable.

\*2 The maximum input capabilities are measured at a 0.1% THD.

**Outputs:**

Outputs	Output voltage	Impedance
REC OUT 1, 2	150 mV (max. 10 V)	600 $\Omega$
PREAMP OUTPUT	1 V (max. 10 V)	
EXT ADPT	150 mV (max. 10 V)	10 k $\Omega$

**Voltage amplification**  
(at 1 kHz):

Input \ Output	REC OUT	EXT ADPT	PREAMP OUTPUT
PHONO 1	35 dB		52 dB
PHONO 2 L	30 dB		47 dB
H	63 dB		80 dB
HEAD AMP	57.5 dB		74.5 dB
MIC	0 dB		17 dB
TUNER			
AUX 1, 2, 3			
TAPE 1, 2			
EXT ADPT			

## Specification Label:

## USA model

<b>SONY®</b>	INTEGRATED STEREO AMPLIFIER
	MODEL NO. TA-8650
	AC 120V                  60Hz                  260W
	SERIAL NO. _____
MADE IN JAPAN	

## AEP, E model

<b>SONY®</b>	INTEGRATED STEREO AMPLIFIER
	MODEL NO. TA - 8650
	AC 100.120.220.240V 50/60Hz 800W
	SERIAL NO. _____
MADE IN JAPAN	

## UK model

<b>SONY®</b>	INTEGRATED STEREO AMPLIFIER
	MODEL NO. TA-8650
	AC 100.120.220.240V 50/60Hz 600W
	SERIAL NO. _____
MADE IN JAPAN	

**SERVICING NOTES**

1. Apply the rated ac line voltage to the set directly. Do not increase the voltage gradually by using a variable transformer or other such instrument: this will cause a V-FET failure.

2. Replacing V-FET

TA-8650 uses six V-FETs (2SK60...3 pcs, 2SJ18...3 pcs) in each channel of its power amplifier. Both 2SK60 and 2SJ18 are divided into six ranks according to their  $V_{sg0}$  (gate-source voltage) and  $V_p$  (cut-off voltage). The bias resistors of the V-FET differ from a rank to a rank, and it is necessary to use the same rank of V-FETs in the same channel.

If you cannot obtain the same rank of V-FET replacement as the one used in the repairing set, replace all six V-FETs. At the same time, replace the bias resistors according to the table given at right.

Rank of 2SK60 2SJ18	Bias Resistors	
	R725, R775	R731, R781 R732, R782
53	33 k $\Omega$	1.8 k $\Omega$
54	33 k $\Omega$	1.5 k $\Omega$
55	33 k $\Omega$	1.2 k $\Omega$
56	30 k $\Omega$	1.0 k $\Omega$
57	30 k $\Omega$	1.0 k $\Omega$
58	30 k $\Omega$	820 $\Omega$

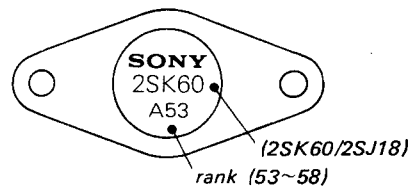

3. After the replacement of V-FET, carry out the following check to avoid further occurrence of V-FET failure.

- 1) Turn off the power of TA-8650.
- 2) Remove the heat sink duct.
- 3) Disconnect the brown and the violet lead wires from the pins on H Board (CLASS B POWER AMP BOARD). See the figure at bottom right.
- 4) Turn on the power and check the voltage across R737 (L-CH)/R787 (R-CH). If the reading does not agree with the value given in the table at right, try adjusting RT701 (L-CH)/RT751 (R-CH).
- 5) If adjusting RT701/RT751 still does not give correct reading, check Q713~Q716 (L-CH)/Q763~Q766 (R-CH). Failure of these transistors will cause V-FET failure.
- 6) After the check, turn off the power of the set and put back the two lead wires mentioned in step 2.

Rank of 2SK60 2SJ18 used in the set	Voltage drop across R737 (L-CH) R787 (R-CH)
53	20.0 V ~ 25.0 V
54	25.0 V ~ 30.0 V
55	30.0 V ~ 35.0 V
56	35.0 V ~ 40.0 V
57	40.0 V ~ 45.0 V
58	45.0 V ~ 50.0 V

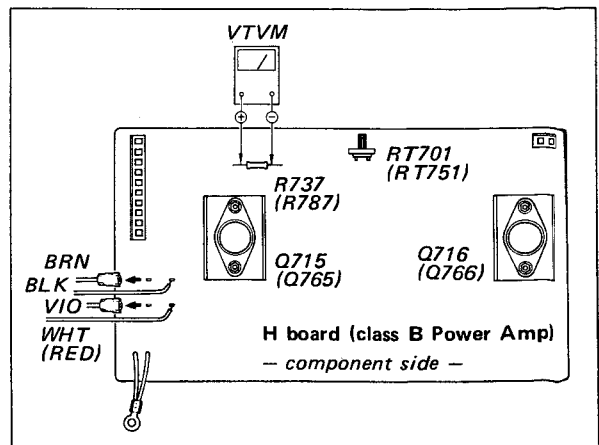
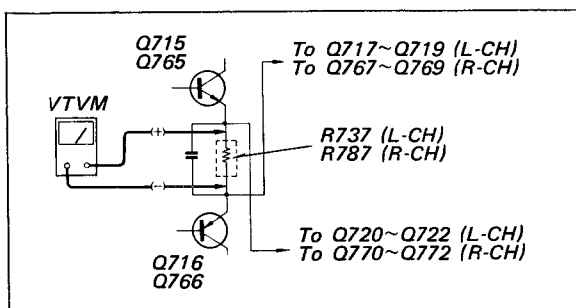

SECTION 1  
BLOCK DIAGRAM

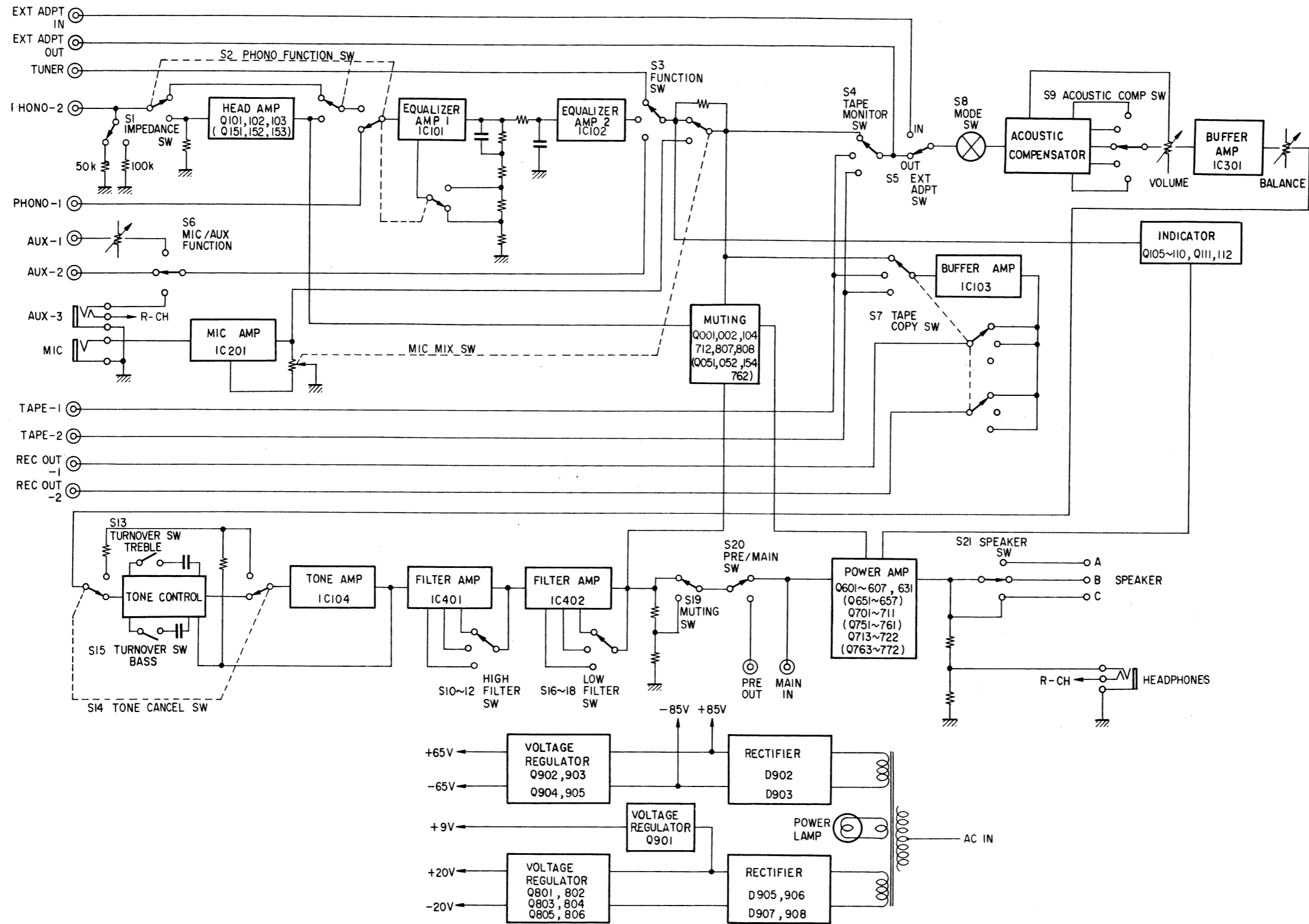

SECTION 2  
DISASSEMBLY AND REPLACEMENT

2-1. CHASSIS LAYOUT

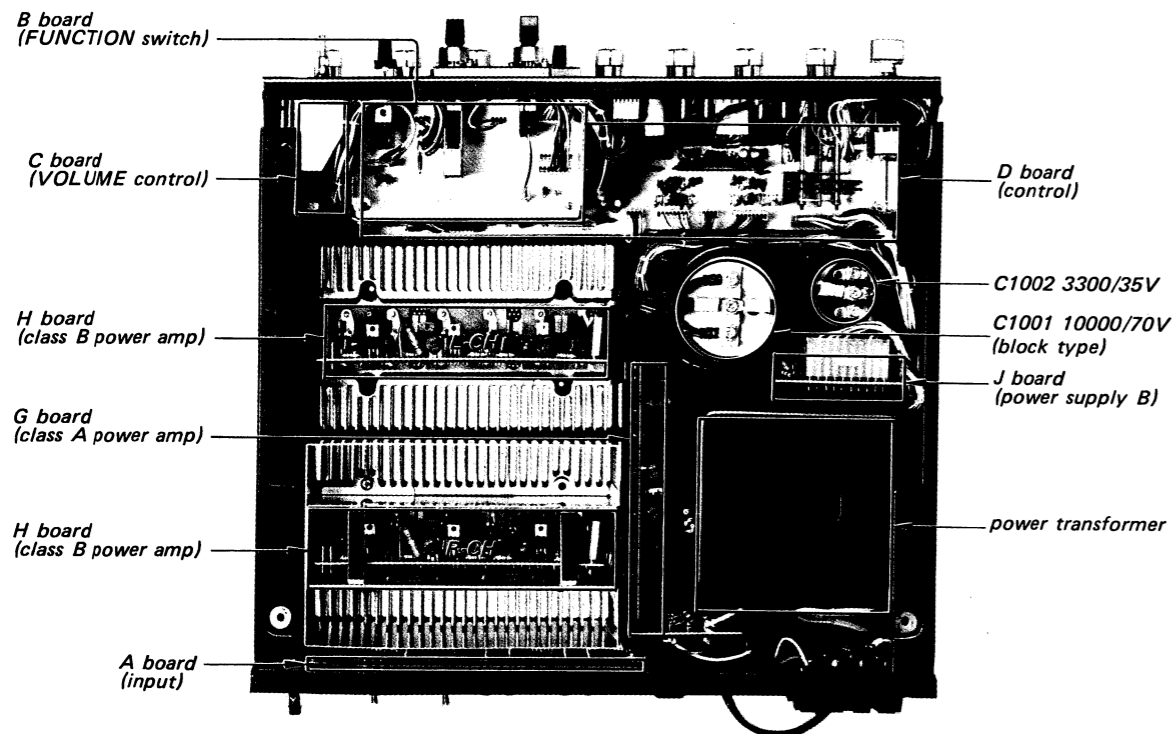

Fig. 2-1. Chassis top view

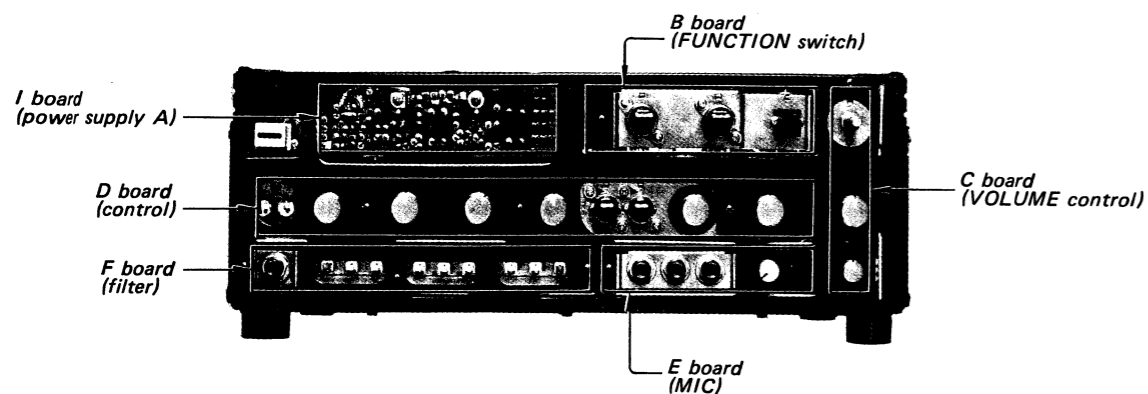

Fig. 2-2. Chassis front view

2-2. PANELS AND KNOBS REMOVAL

Front Panel

Remove ①, ②, ③, ④, and ⑤.

Control Panel

Remove the front panel.

Remove ⑥.

Front Subchassis

Remove the front panel.

Remove ⑦.

Rear Panel

Remove ⑧.

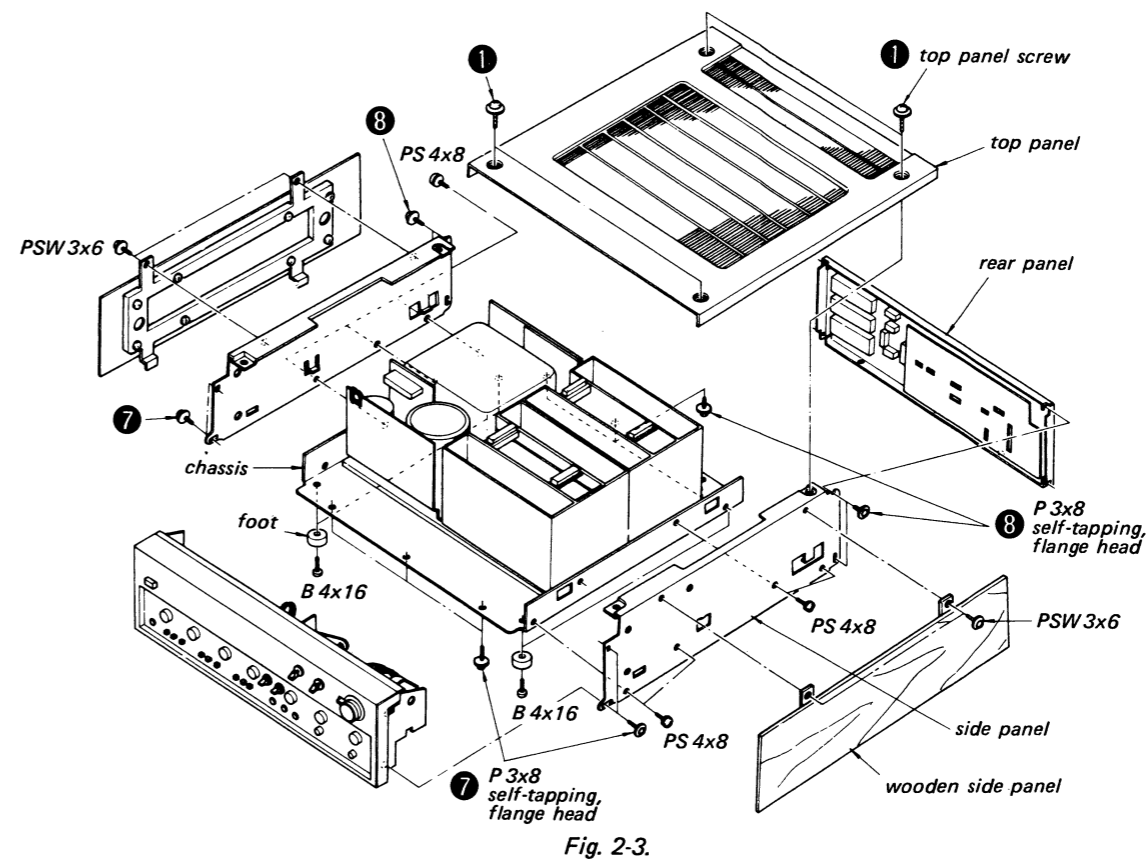

Fig. 2-3.

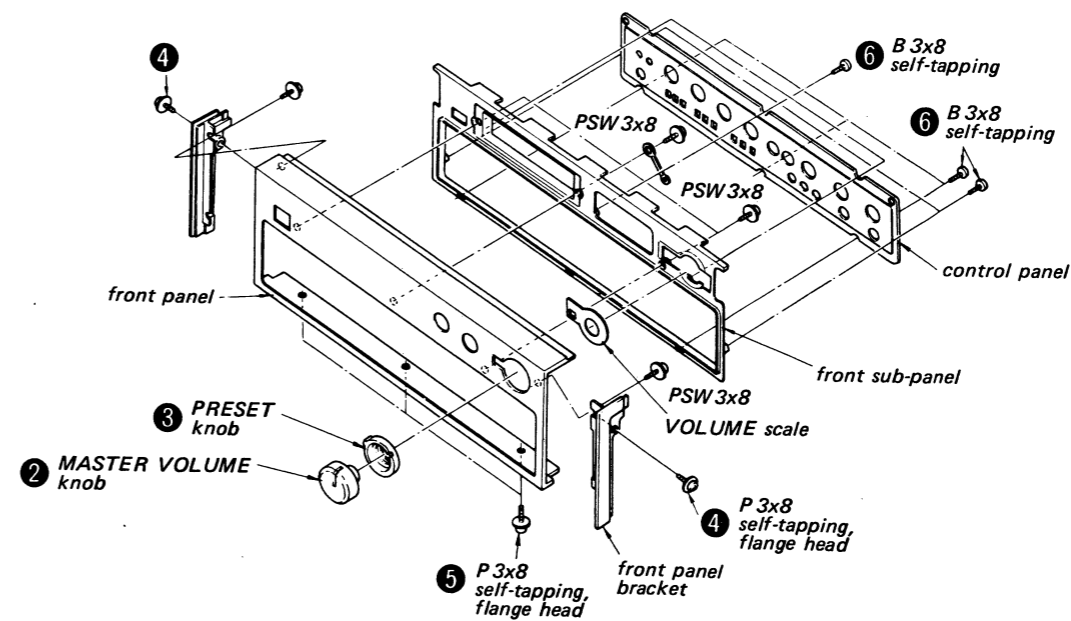

Fig. 2-4.

**Knobs Removal**

MASTER VOLUME knob } .... loosen the set screw.  
 PRESET knob }  
 POWER switch knob ..... remove the front panel and pull out the knob from switch.

Pushbuttons ..... remove the front panel and push out the knobs.  
 Other knobs ..... pull out the knobs

**2-3. CIRCUIT BOARD REMOVAL AND V-FET REPLACEMENT**

**Note:** Be careful with the position and the direction of the connectors when reinstalling them to the circuit boards. See Fig. 2-5.

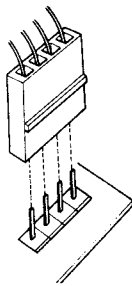

Fig. 2-5.

**< G board >**

Remove ⑰  
 Pull up the board.

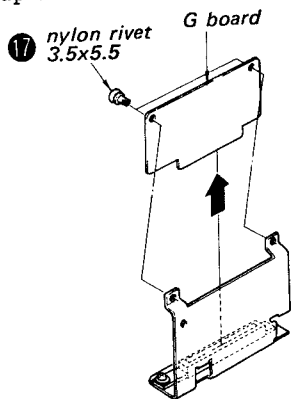

Fig. 2-6.

**< A board >**

Remove the rear panel.

Remove ⑨, ⑩, and ⑪

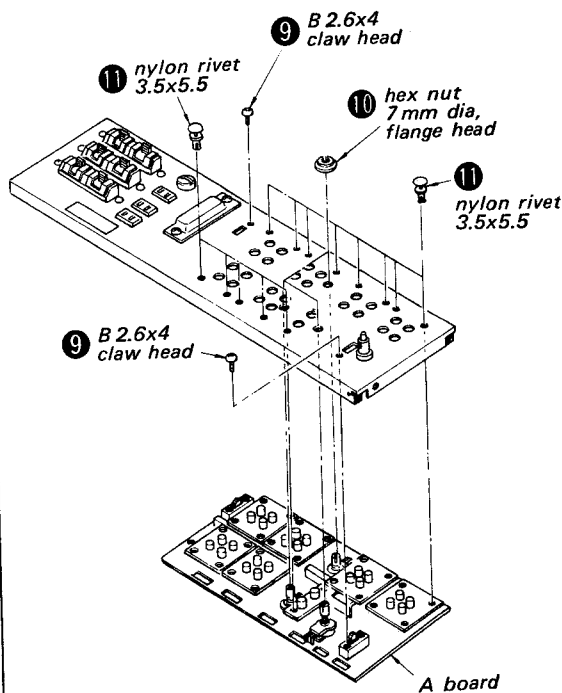

Fig. 2-8.

**< B, C, D, E, and F boards >**

Remove the front sub-panel.

Remove ⑫ ~ ⑯

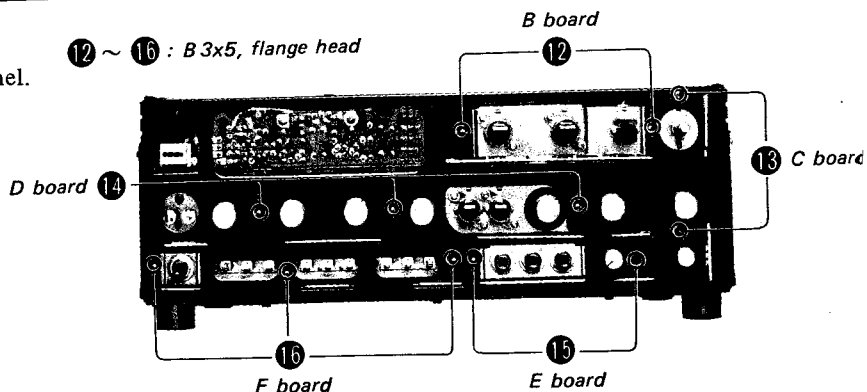

Fig. 2-7.

< H board >

Remove the heat sink duct (remove 18 ).

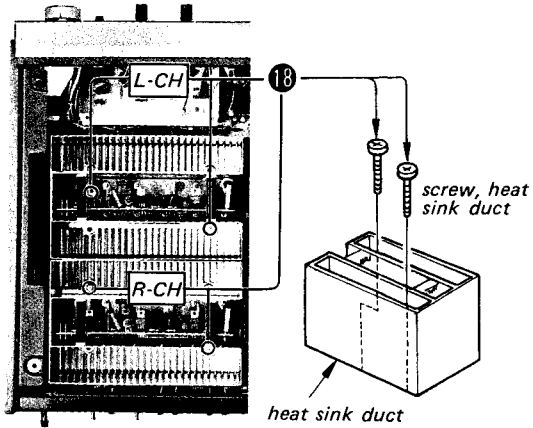

Fig. 2-9.

Remove 19 and take out the heat sink with the circuit board.

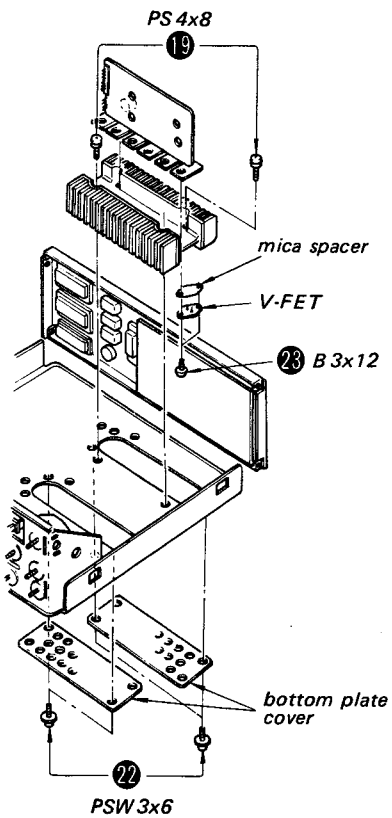

Fig. 2-10.

< I board >

Remove 20

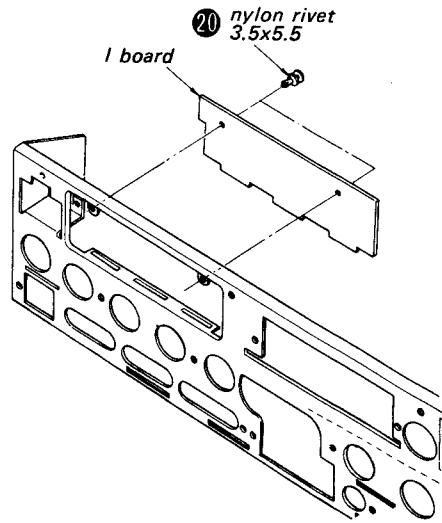

Fig. 2-11.

< J board >

Remove 21

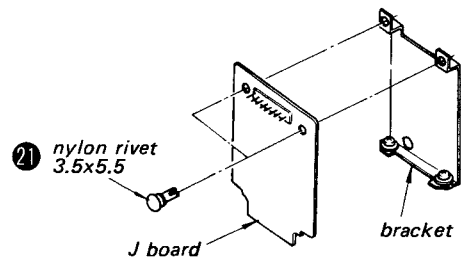

Fig. 2-12.

< V-FET Replacement >

Remove 22 and 23 (Fig. 2-10).



**MEMO**

A series of horizontal dotted lines for writing.

### SECTION 3 DC BALANCE AND BIAS ADJUSTMENTS

**Note 1.** Apply the rated ac line voltage to the set directly. Do not increase the voltage gradually by using a variable transformer or other such instruments: this will cause a V-FET failure.

2. Turn on the power of the set and wait a few minutes for warm-up.
3. Alternately repeat the two adjustments 2~3 times.

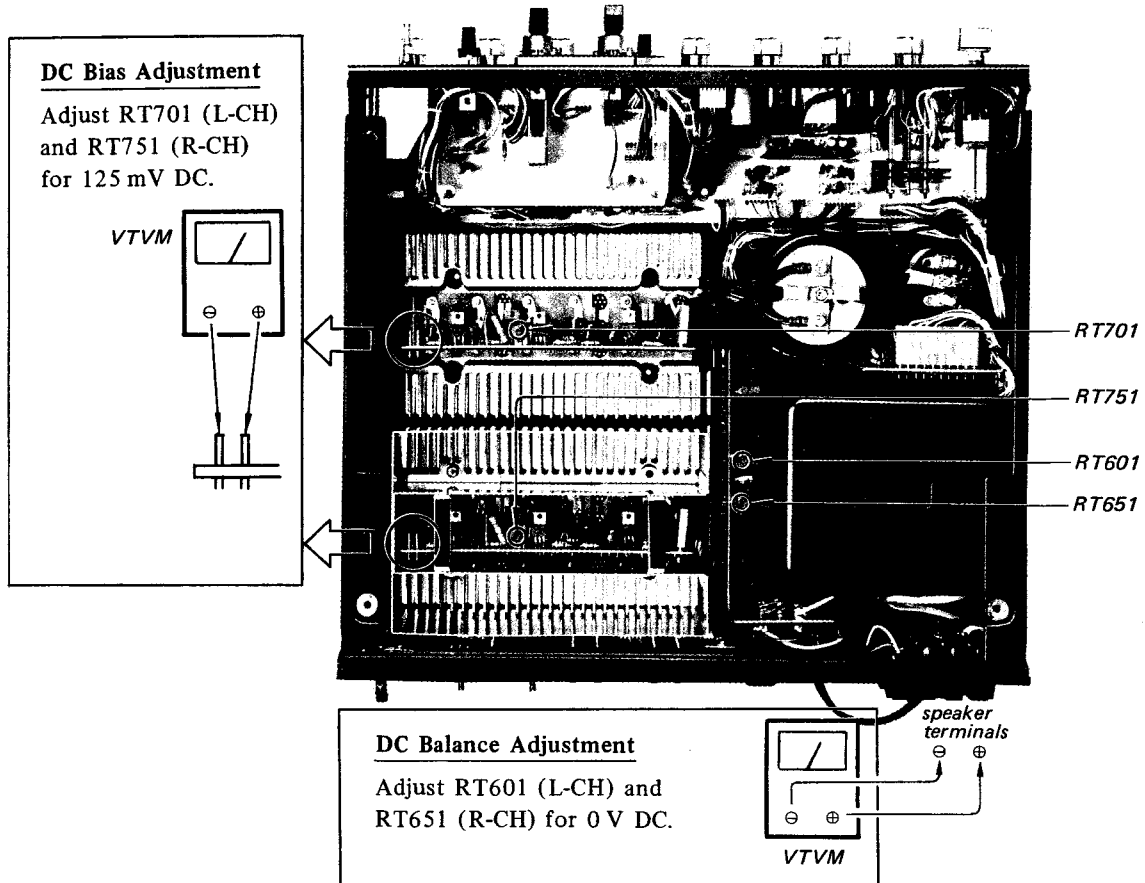
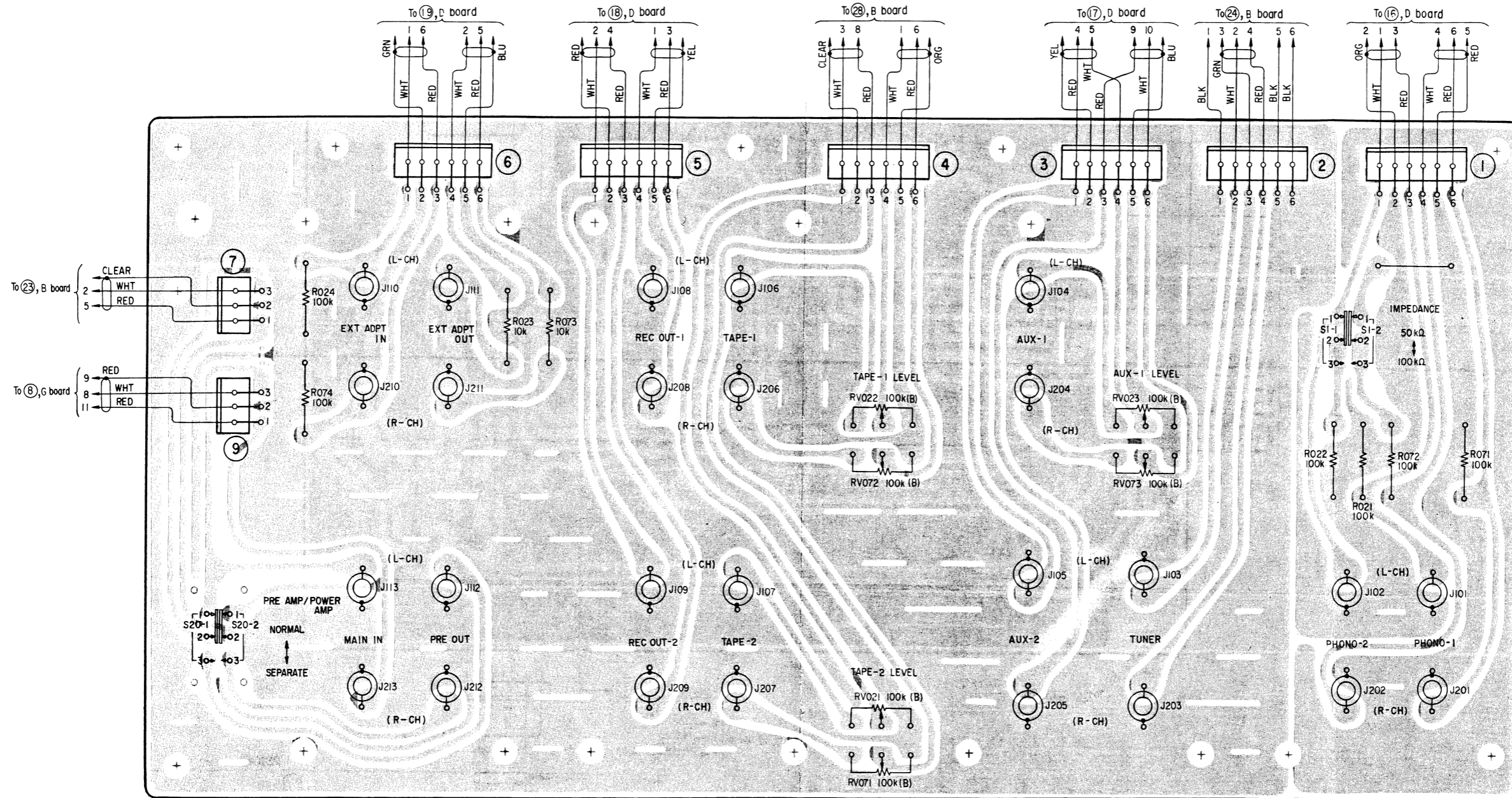

Fig. 3-1.

SECTION 4  
DIAGRAMS

4-1. MOUNTING DIAGRAM - A Board INPUT -

- Conductor Side -



4-2. MOUNTING DIAGRAM — B Board FUNCTION SWITCH —

— Conductor Side —

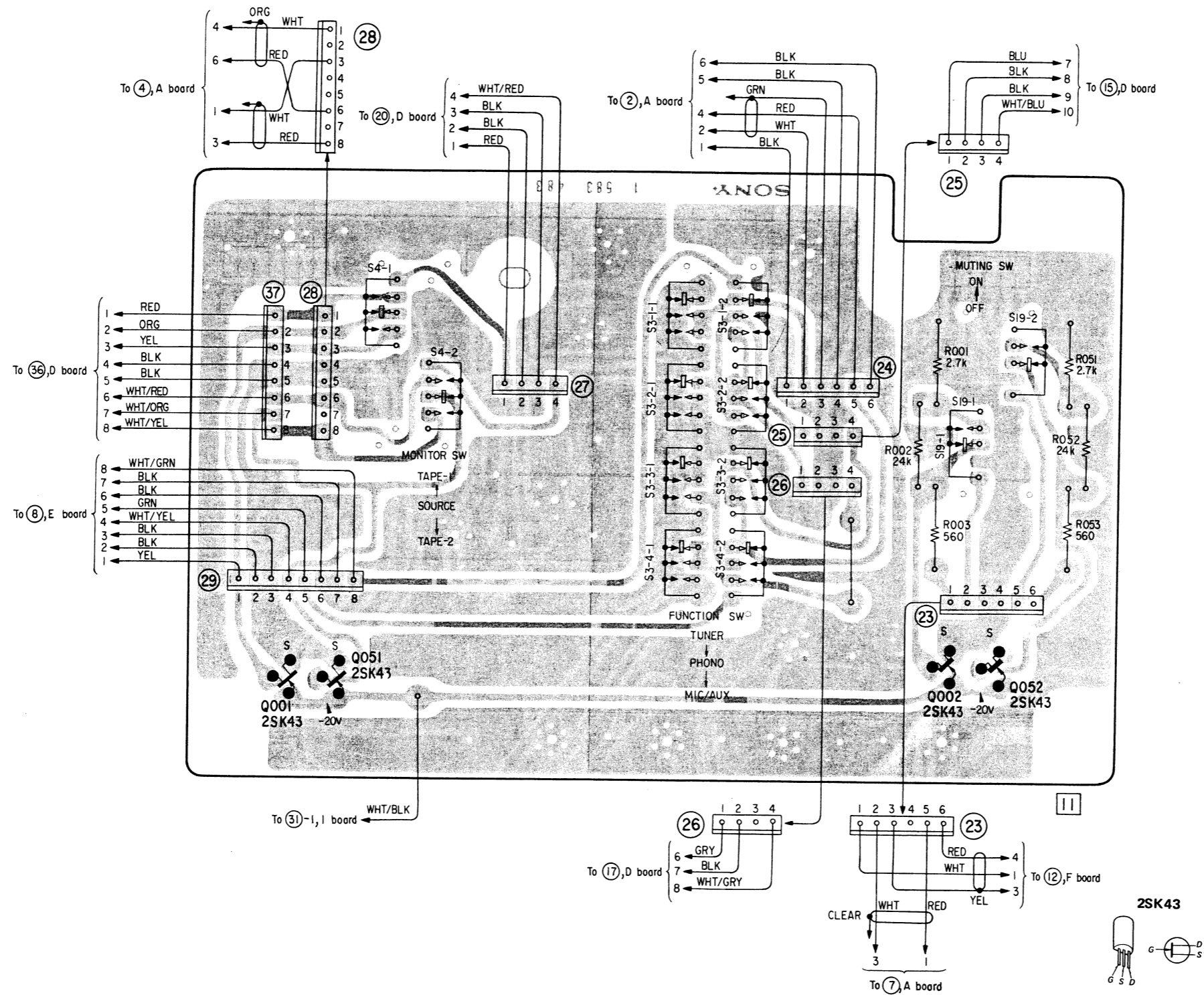

4-3. MOUNTING DIAGRAM - F Board **FILTER** -

- Conductor Side -

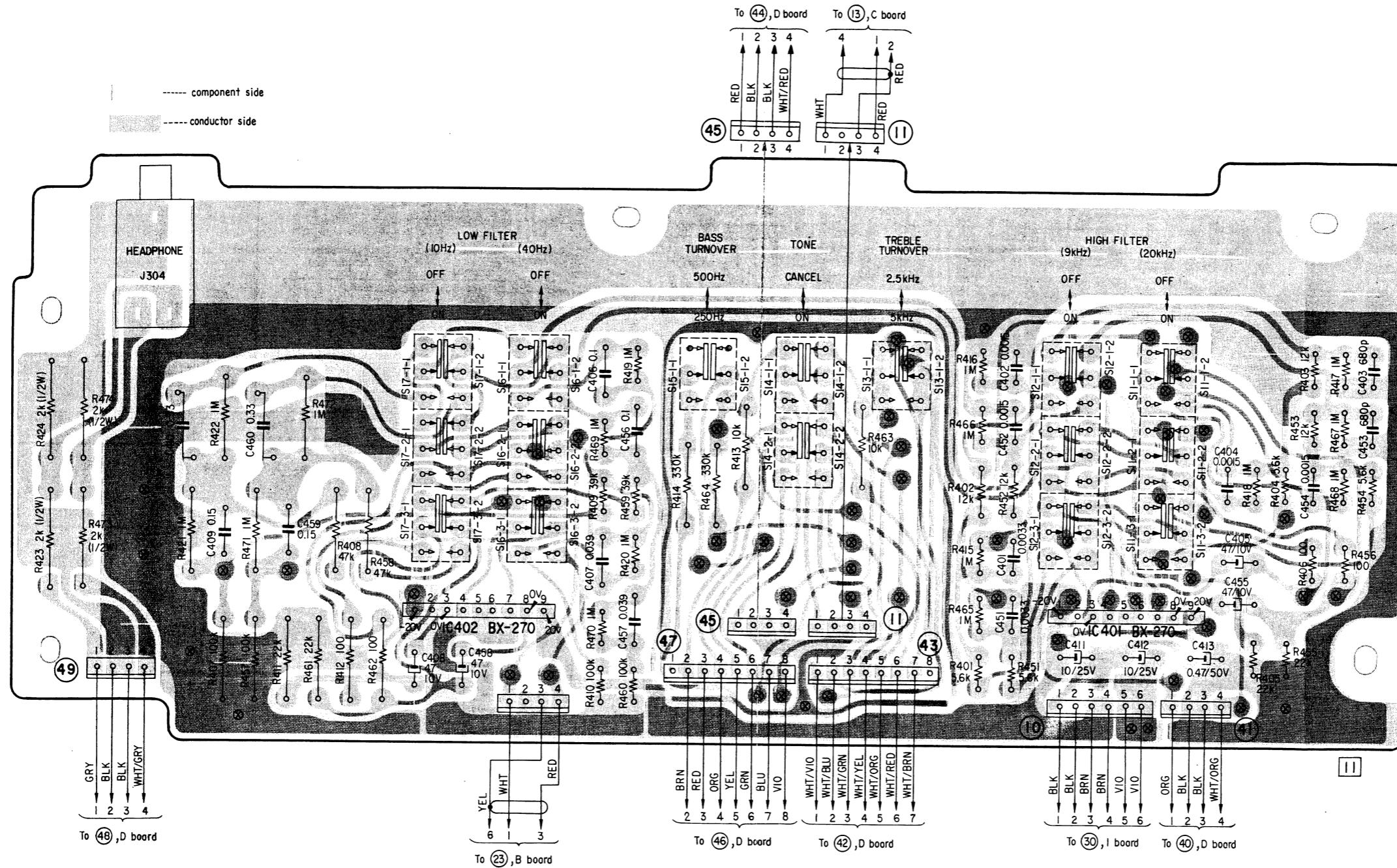

BX-270

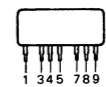

4.4. MOUNTING DIAGRAM - J Board POWER SUPPLY B -  
- Conductor Side -

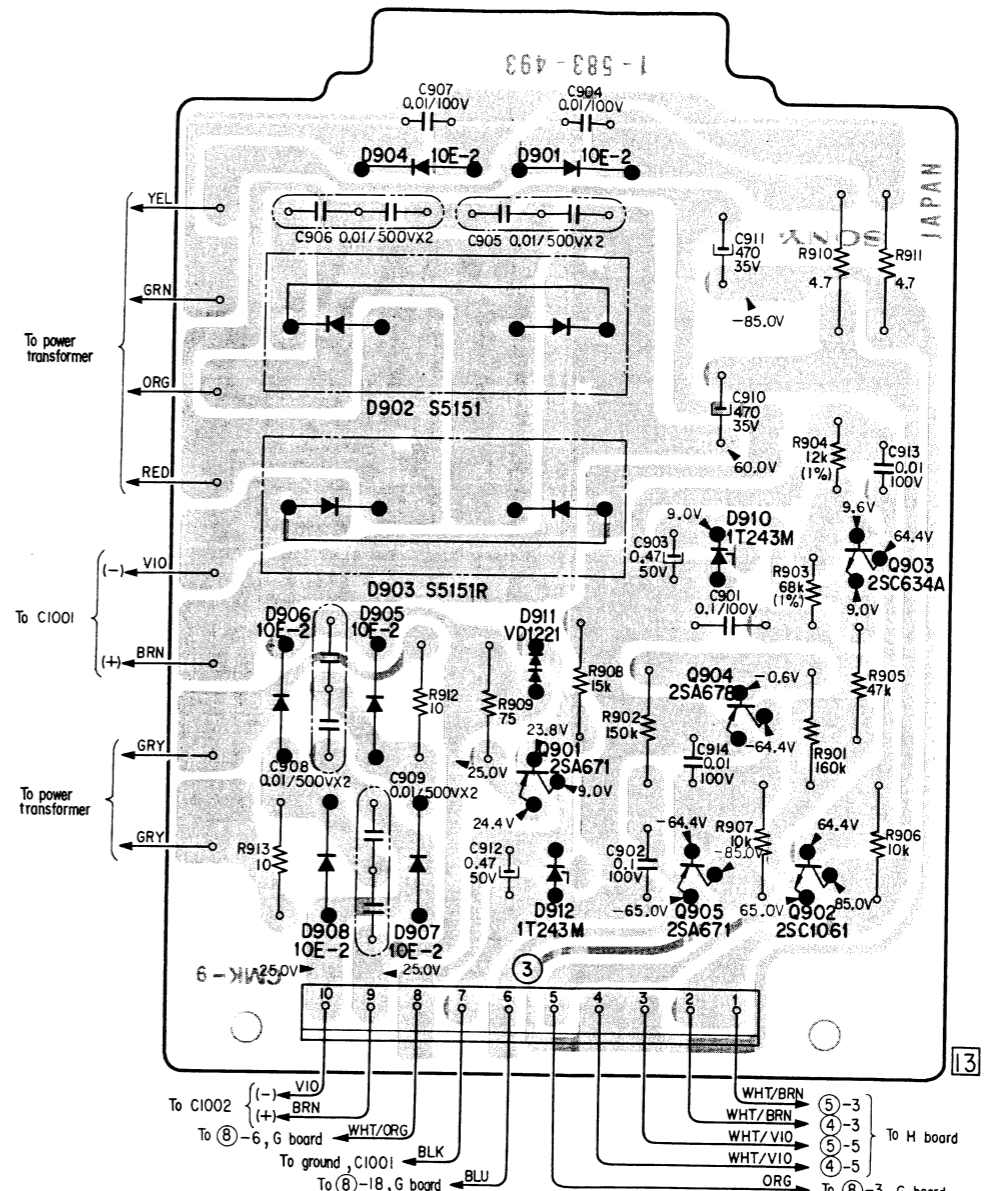
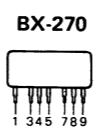
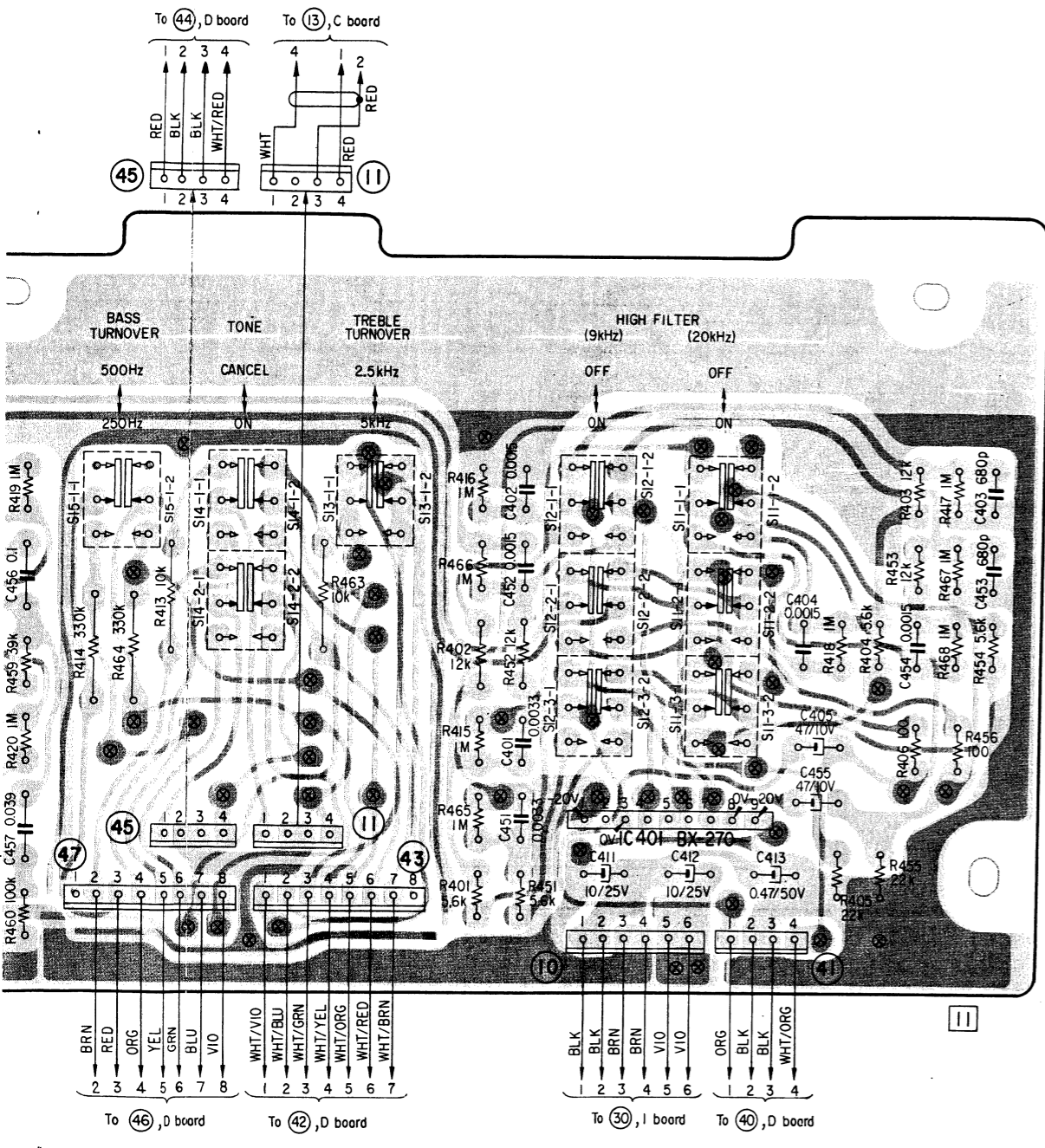

Semiconductor Location

D904	D901	D910	Q903
D906	D905	D911	Q904
D902	D903	Q901	Q905
D908	D907	D912	Q902

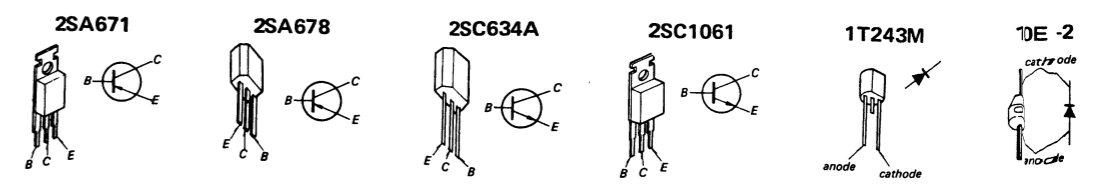
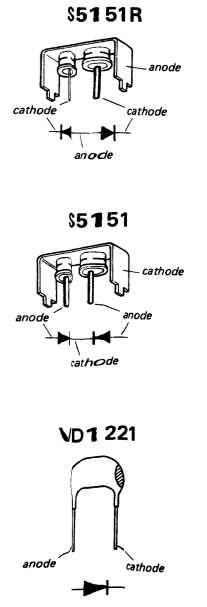



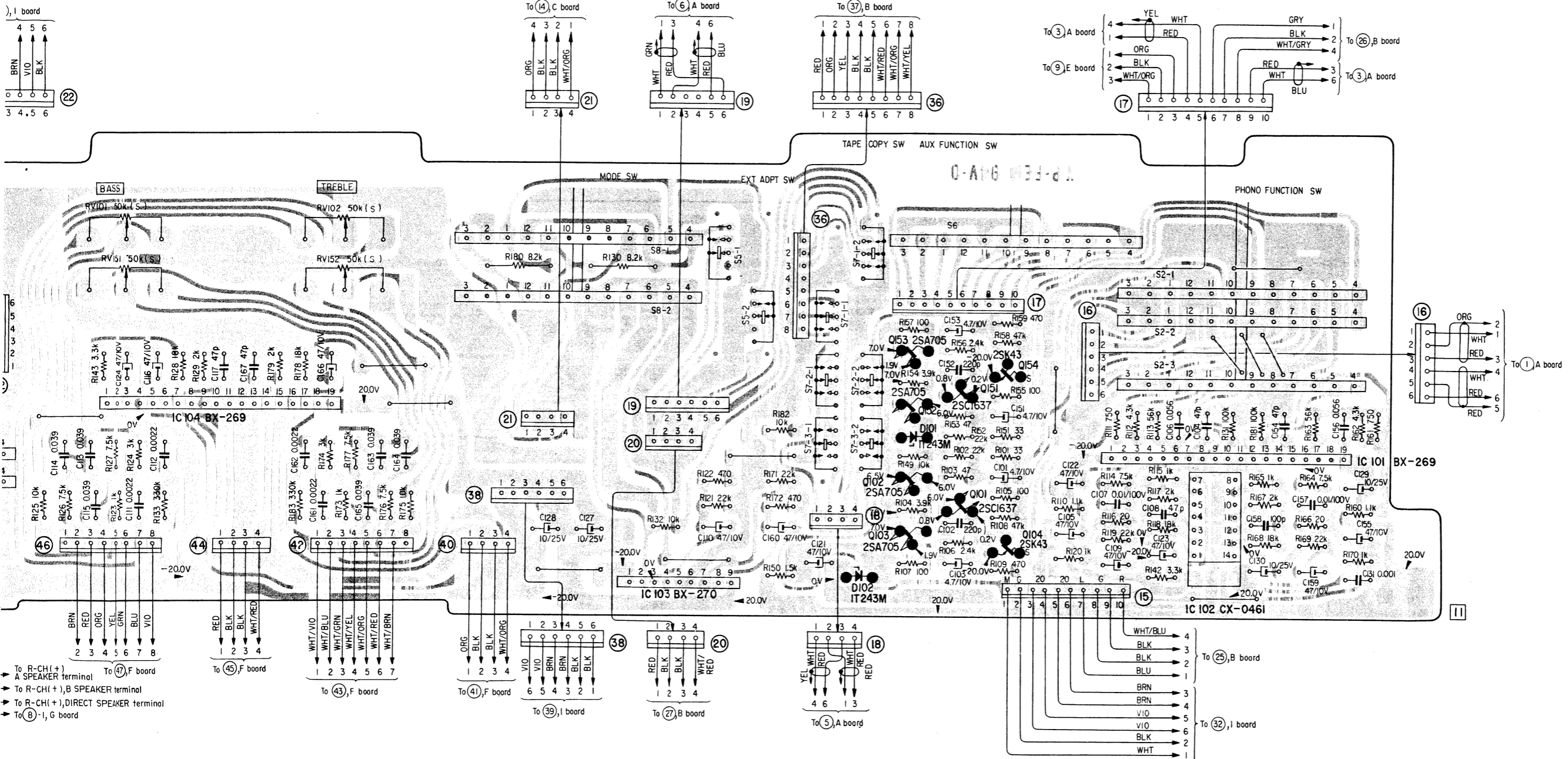

→ To R-CH(+) A SPEAKER terminal  
 → To R-CH(+) B SPEAKER terminal  
 → To R-CH(+), DIRECT SPEAKER terminal  
 → To (B)-I, G board

IC104

IC103

D102  
 Q153  
 Q152  
 D101  
 Q102  
 Q103

Q151  
 Q154  
 Q101  
 Q104

IC101  
 IC102

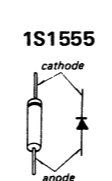
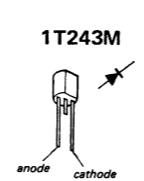
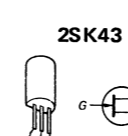
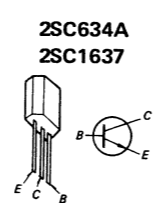
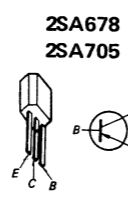
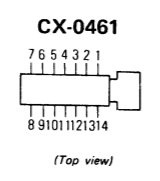
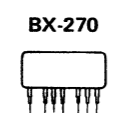
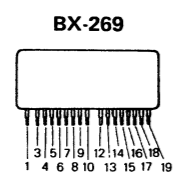

\* D104 and D105 are mounted on a small printed circuit board which stands on D board at 90°.



4-6. MOUNTING DIAGRAM – C Board **VOLUME CONTROL** –

– Conductor Side –

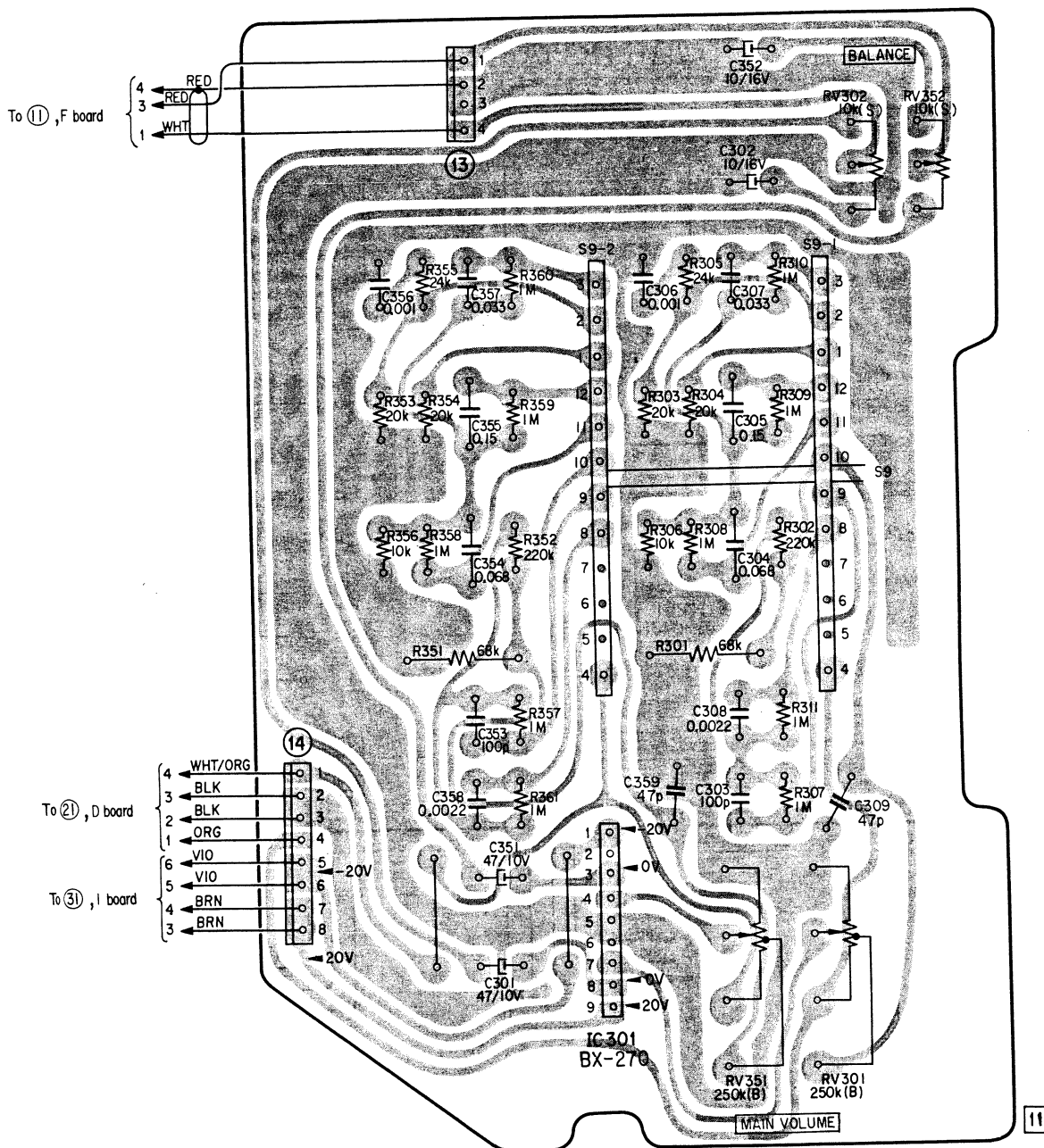

BX-270



**E**

4-7. MOUNTING DIAGRAM – E Board **MIC AMP** –

– Conductor Side –

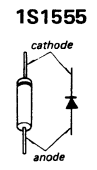
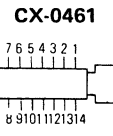
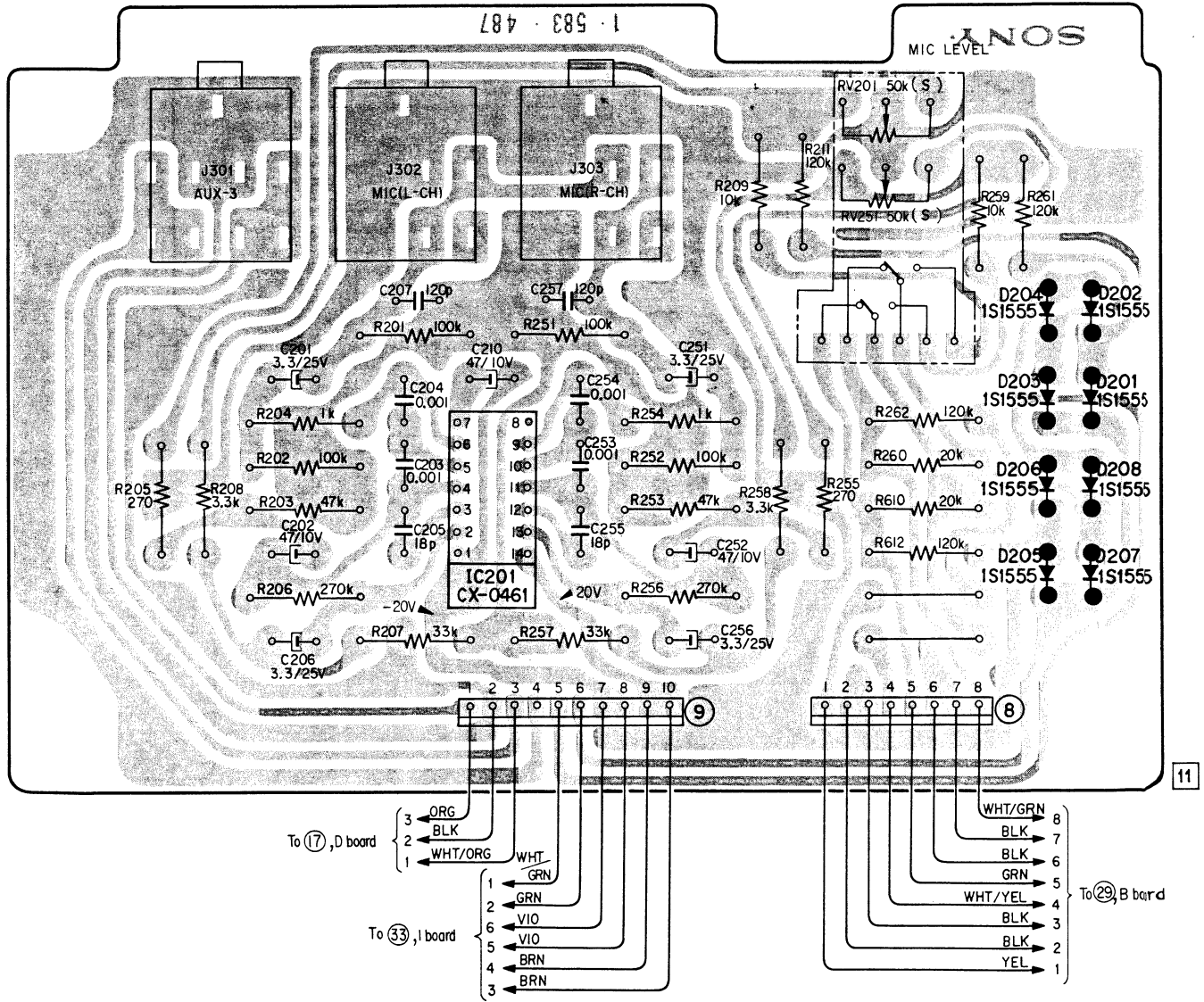

4-8. SCHEMATIC DIAGRAM — Preamp Section —

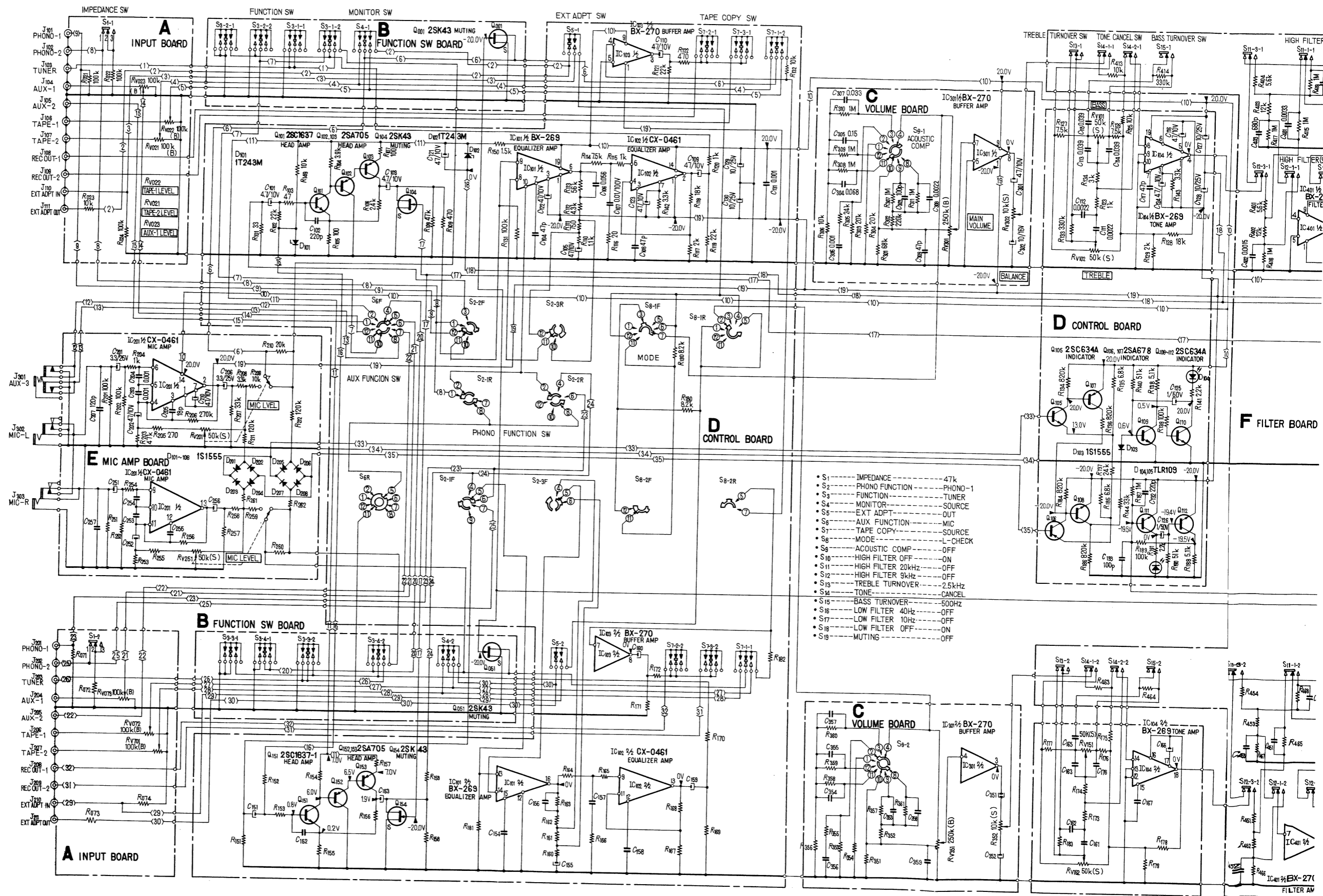

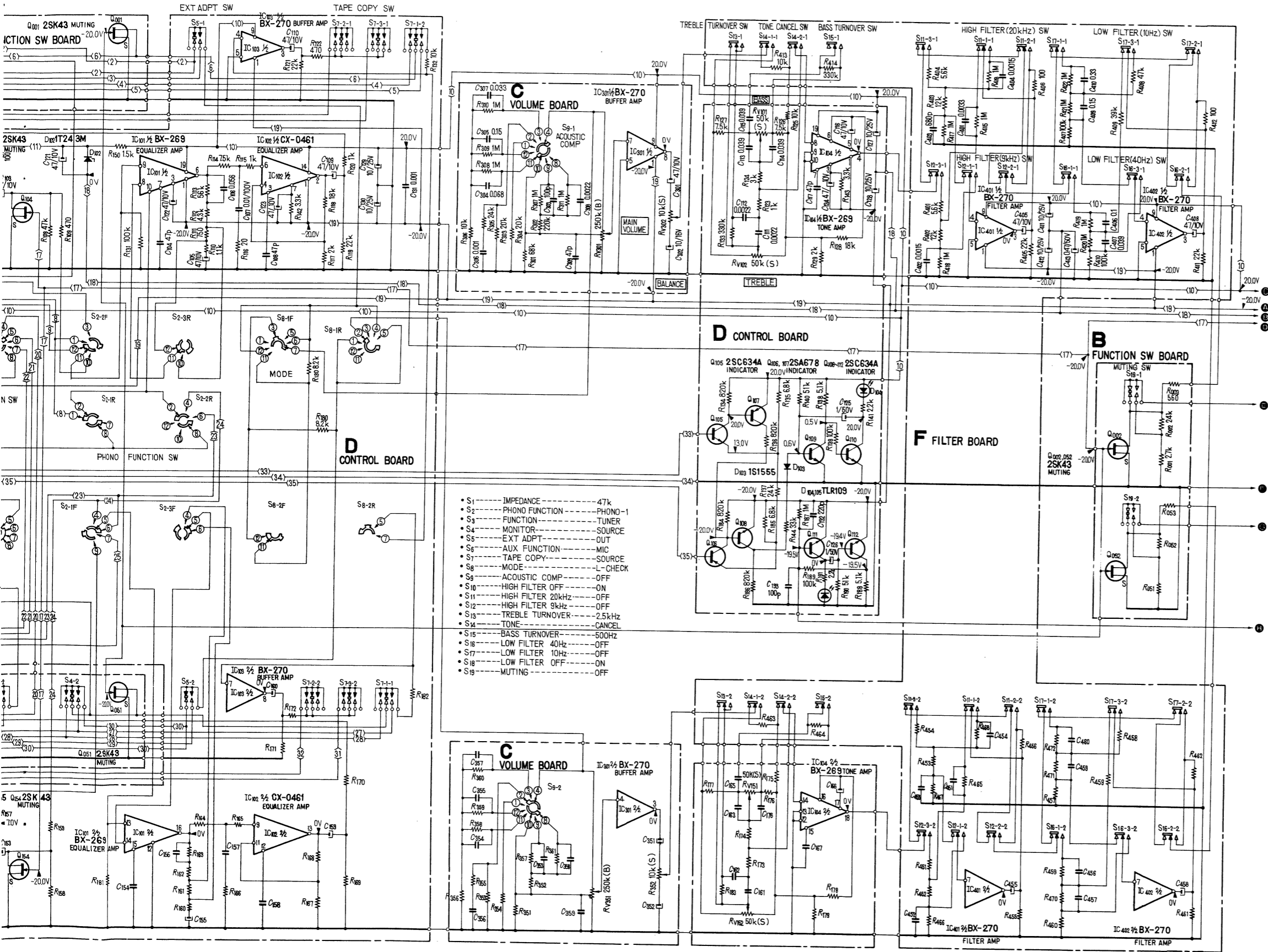

4-9. SCHEMATIC DIAGRAM - Power Amp Section -

**G CLASS A POWER AMP BOARD**

USA Model only: Up to Serial No. 800,140

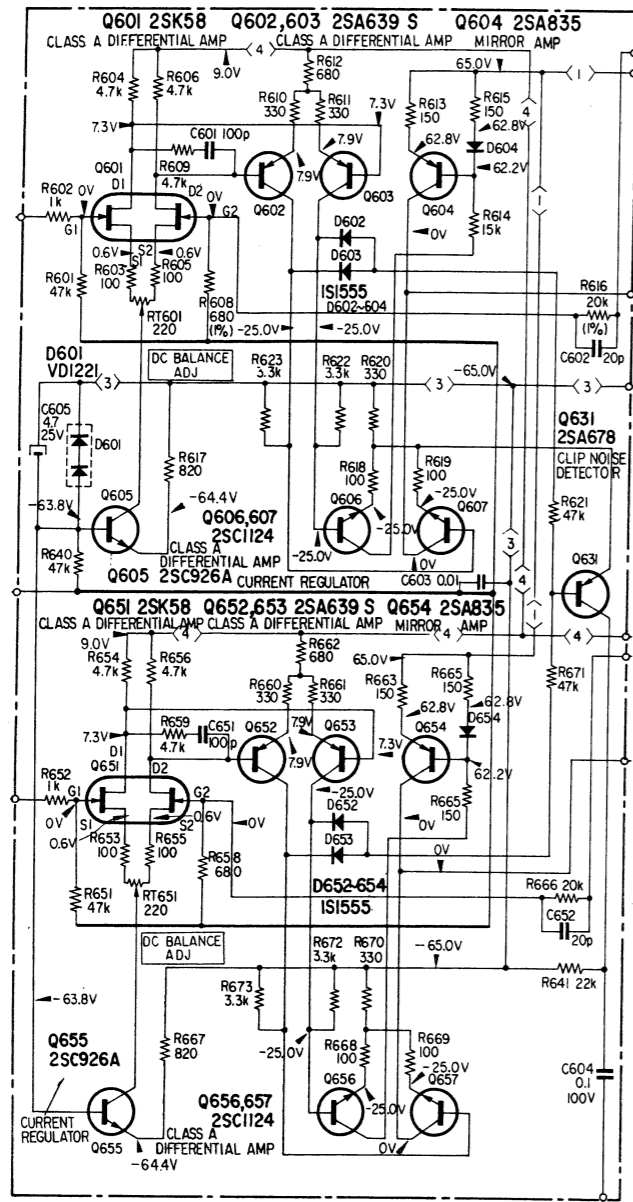

**G CLASS A POWER AMP BOARD**

USA Model: Serial No. 800,141 and later

UK Model: Serial No. 600,001 and later

AEP Model: Serial No. 500,001 and later

E Model: Serial No. 400,001 and later

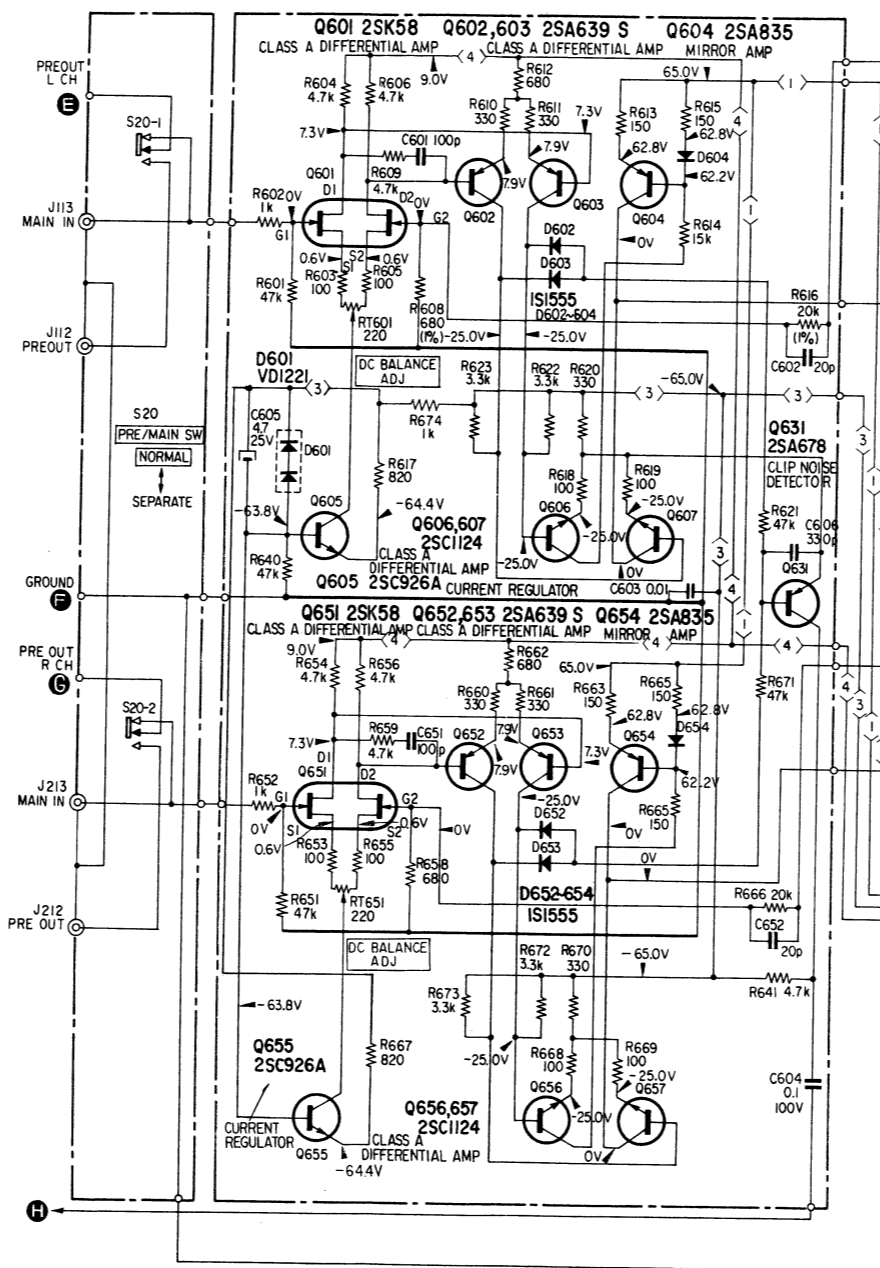

**Note:**  
 All resistance values are in ohms. (k = 1,000, M = 1,000 k)  
 All capacitance values are in  $\mu$ F except as indicated with p, which means  $\mu$ F.  
 All voltages are dc measured with a VOM which has an input impedance of 20 k ohms/volt. No signal in.  
 Voltage variations may be noted due to normal production tolerances.

**H CLASS B POWER AMP BOARD (L-CH)**

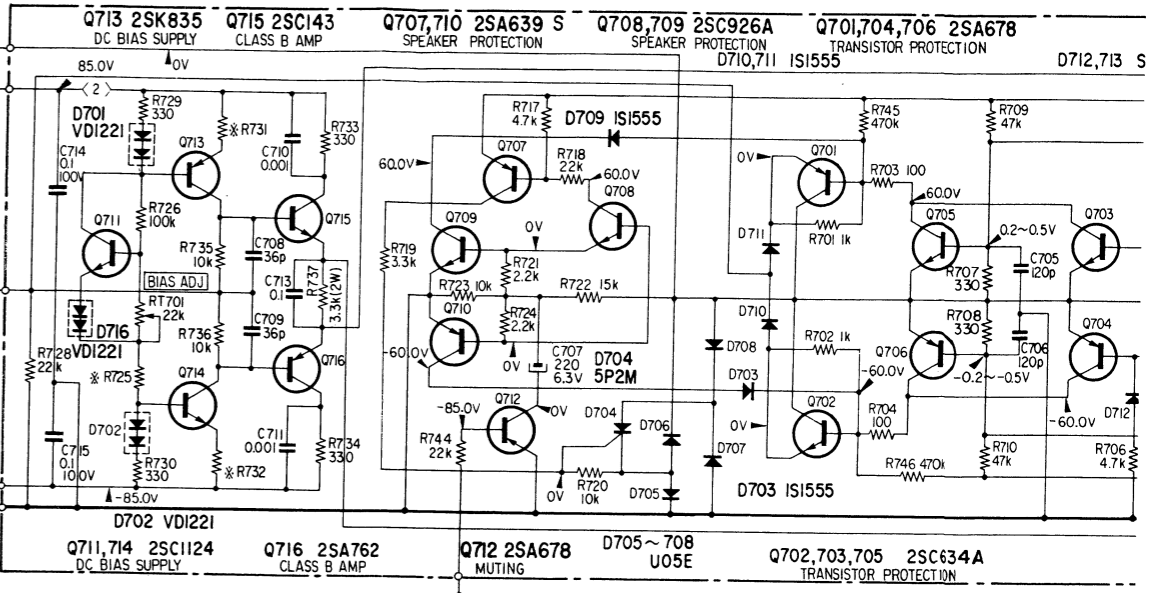

**H CLASS B POWER AMP BOARD (R-CH)**

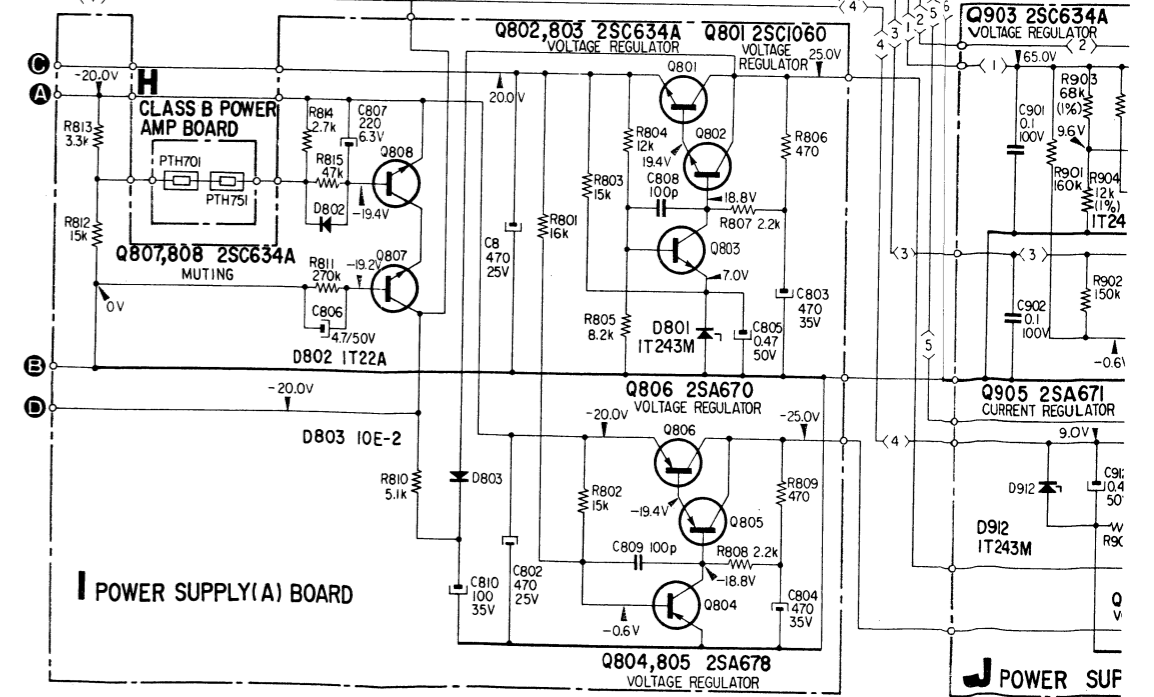
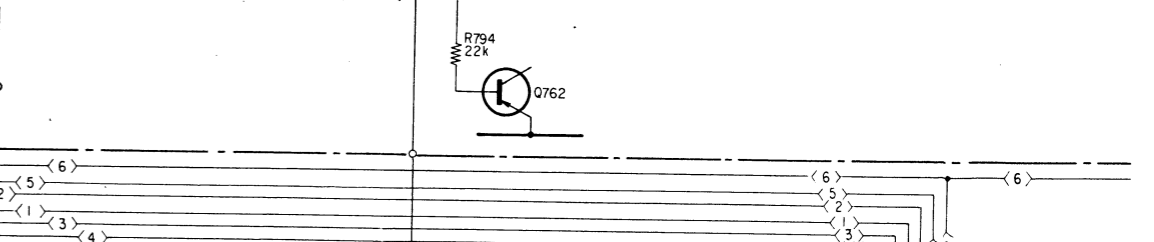

Q717-719 Q720-722 2SK601 2SJ18	* R725, 775	* R731, 781 * R732, 782	* A	* B
-53	33k	1.8k	-9.4V ~ -11.9V	9.4V ~ 11.9V
-54	33k	15k	-11.9V ~ -14.4V	11.9V ~ 14.4V
-55	33k	1.2k	-14.4V ~ -16.9V	14.4V ~ 16.9V
-56	30k	1.0k	-16.9V ~ -19.4V	16.9V ~ 19.4V
-57	30k	1.0k	-19.4V ~ -21.9V	19.4V ~ 21.9V
-58	30k	620	-21.9V ~ -24.4V	21.9V ~ 24.4V

# TA-8650 TA-8650

Q717~719 2SK60	* R725, 775	R731, 781 * R732, 782	* A	* B
-53	33k	1.8k	-9.4V ~ -11.9V	9.4V ~ 11.9V
-54	33k	1.5k	-11.9V ~ -14.4V	11.9V ~ 14.4V
-55	33k	1.2k	-14.4V ~ -16.9V	14.4V ~ 16.9V
-56	30k	1.0k	-16.9V ~ -19.4V	16.9V ~ 19.4V
-57	30k	1.0k	-19.4V ~ -21.9V	19.4V ~ 21.9V
-58	30k	820	-21.9V ~ -24.4V	21.9V ~ 24.4V

## CLASS A POWER AMP BOARD

SA Model: Serial No. 800,141 and later  
 JK Model: Serial No. 600,001 and later  
 EP Model: Serial No. 500,001 and later  
 E Model: Serial No. 400,001 and later

## H CLASS B POWER AMP BOARD (L-CH)

## H CLASS B POWER AMP BOARD (R-CH)

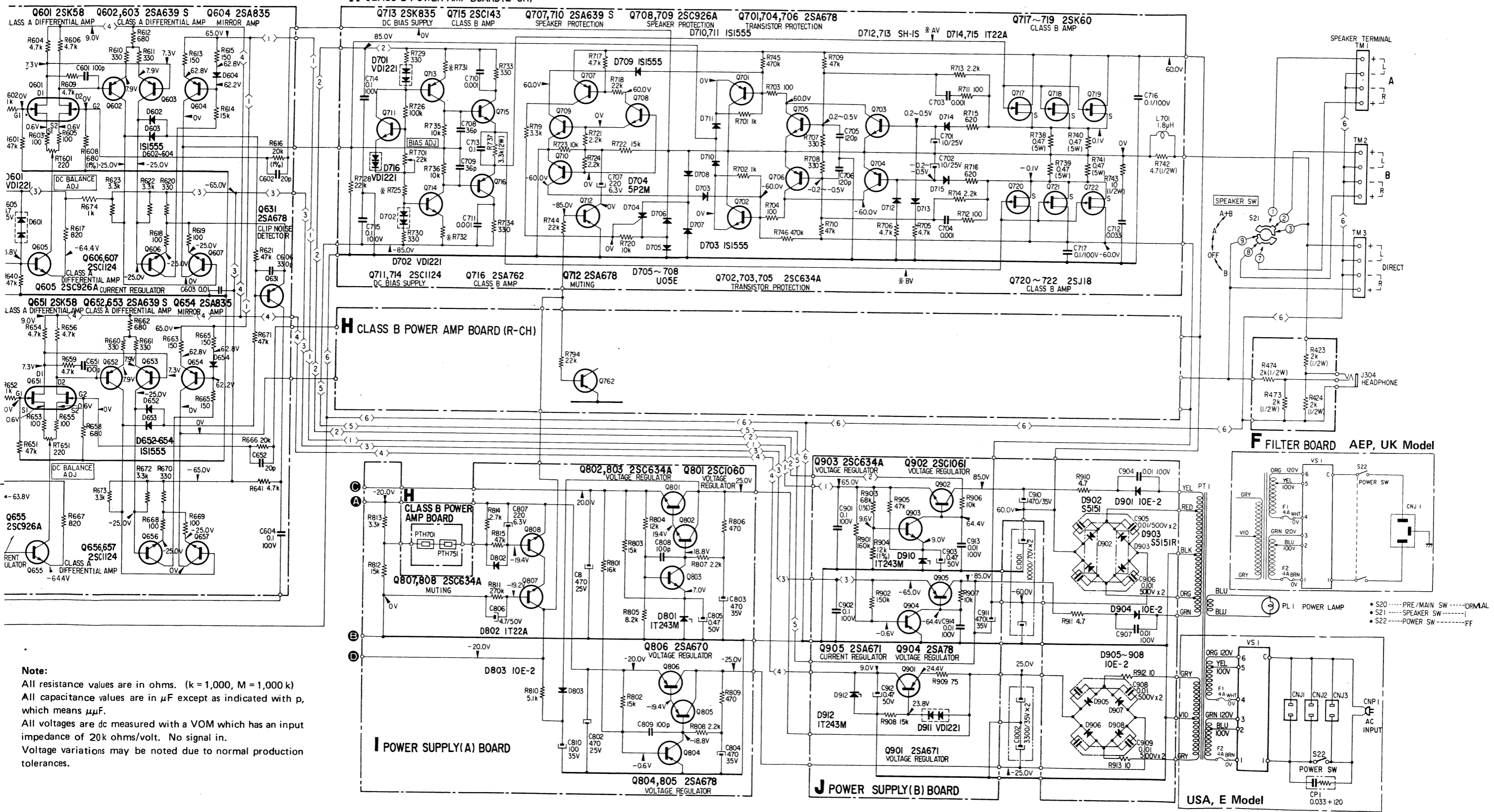

**Note:**  
 All resistance values are in ohms. (k = 1,000, M = 1,000 k)  
 All capacitance values are in  $\mu\text{F}$  except as indicated with p, which means  $\mu\text{F}$ .  
 All voltages are dc measured with a VOM which has an input impedance of 20k ohms/volt. No signal in.  
 Voltage variations may be noted due to normal production tolerances.

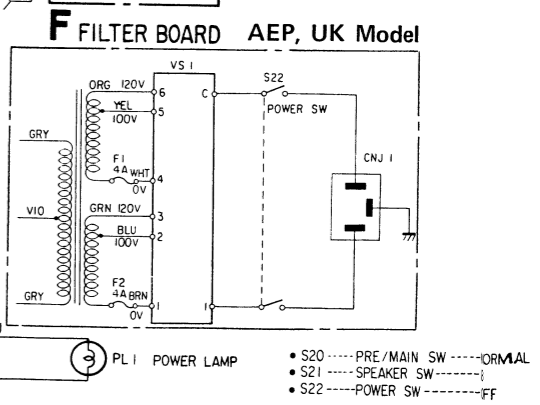

USA, E Model

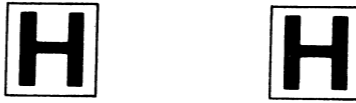

4-10. MOUNTING DIAGRAM - H Board CLASS B POWER AMP -

- Conductor Side -

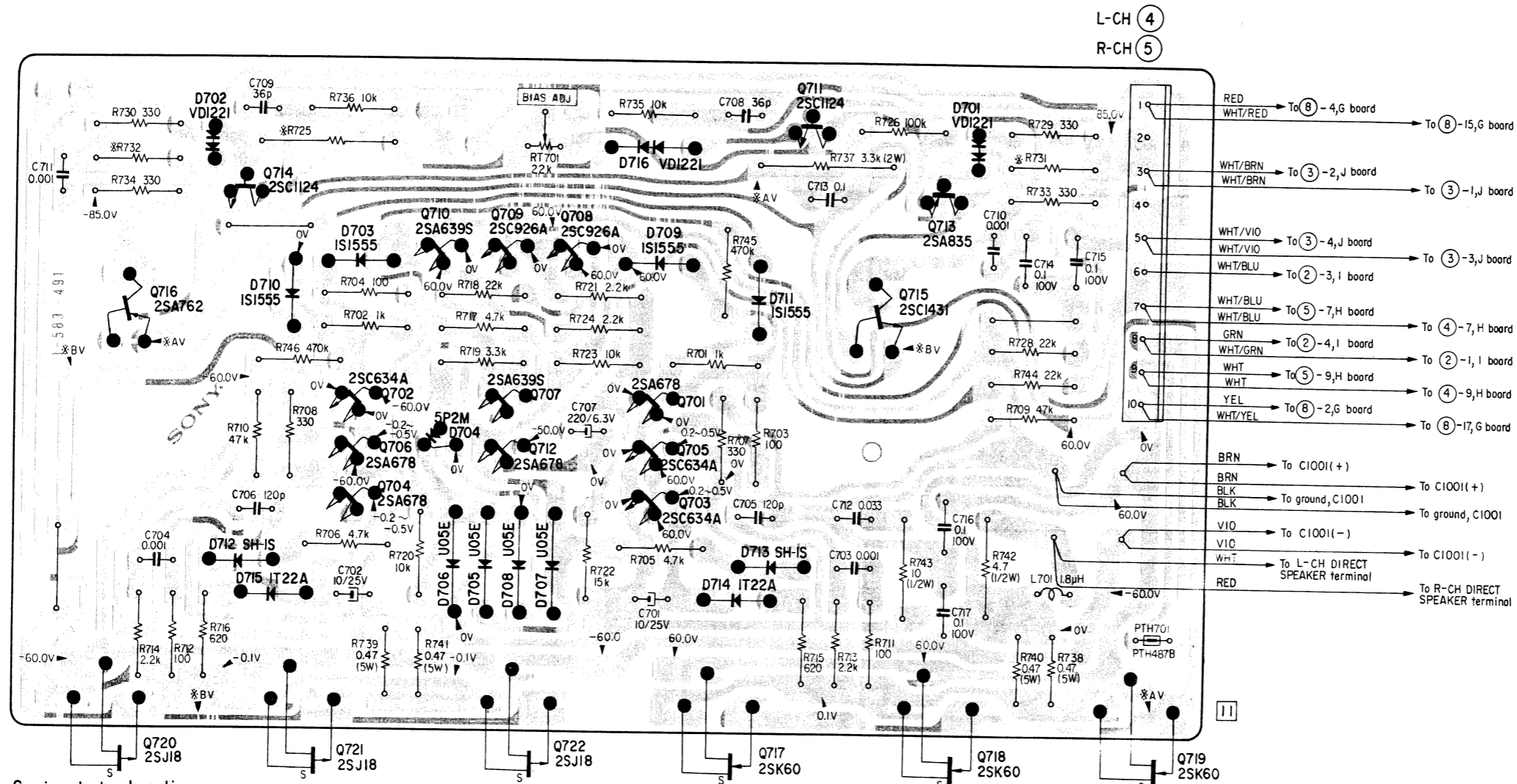

Semiconductor Location

Q716	D702	Q714	D710	D703	Q710	Q709	Q708	D716	Q711	D701	
				Q702	D704	Q707		D709	D711	Q715	Q713
		D712	D715	Q706		Q712		Q701			
				Q704	D706	D705	D708	Q705	D713		
Q720		Q721					Q707	Q703	D714	Q718	Q719
							Q722		Q717		

*			A	B
Q717~719	R725, 775	R731, 781	-9.4V~-11.9V	9.4V~11.9V
Q720~722		R732, 782	-11.9V~-14.4V	11.9V~14.4V
2SK60	33k		-14.4V~-16.9V	14.4V~16.9V
2SJ18	33k		-16.9V~-19.4V	16.9V~19.4V
	30k		-19.4V~-21.9V	19.4V~21.9V
	30k		-21.9V~-24.4V	21.9V~24.4V

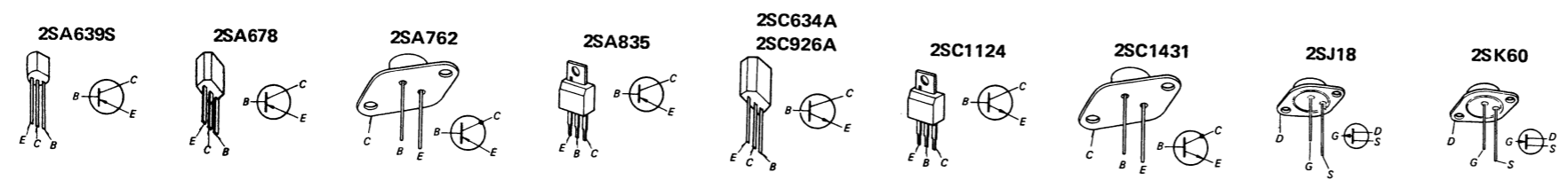



**MEMO**

L-CH (4)  
R-CH (5)

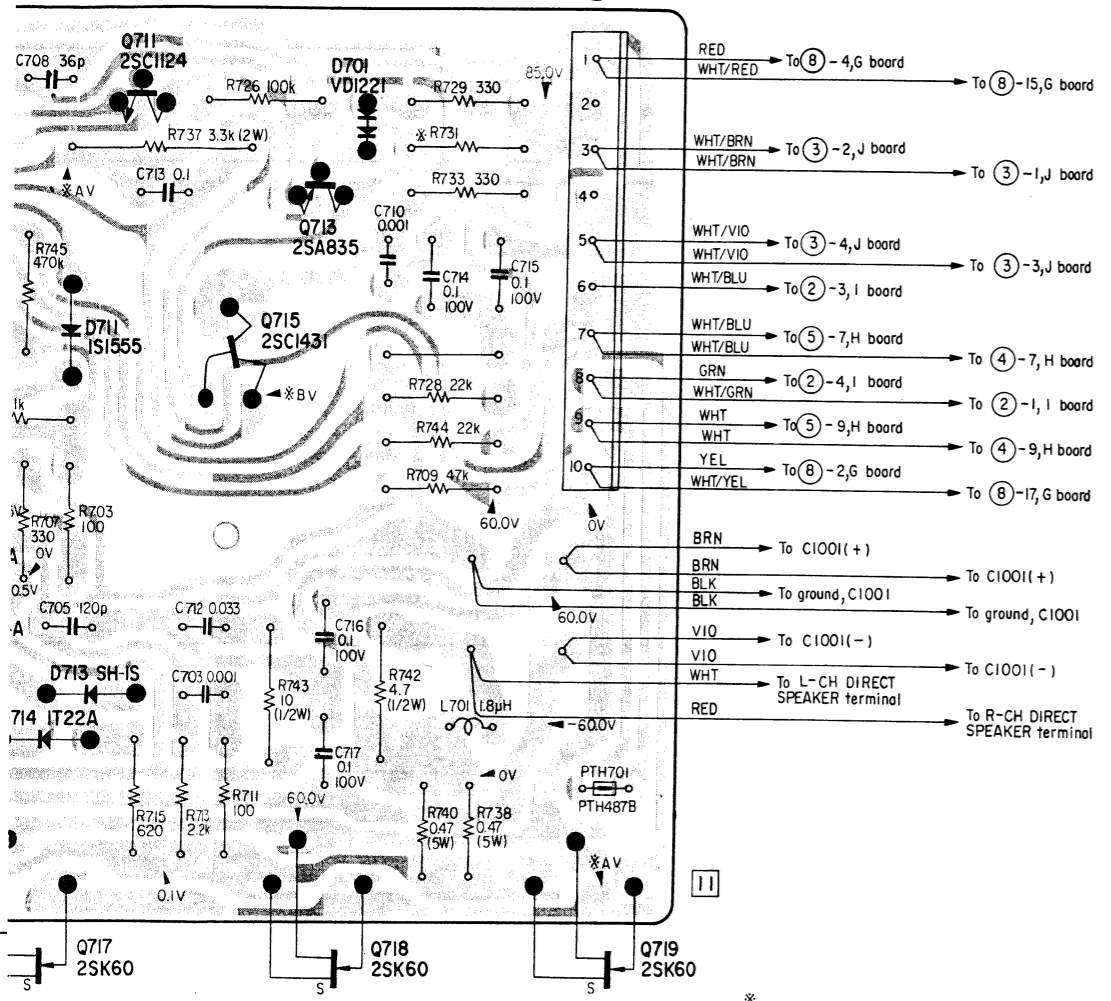

- RED → To (8) -4, G board
- WHT/RED → To (8) -15, G board
- WHT/BRN → To (3) -2, J board
- WHT/BRN → To (3) -1, J board
- WHT/VIO → To (3) -4, J board
- WHT/VIO → To (3) -3, J board
- WHT/BLU → To (2) -3, I board
- WHT/BLU → To (5) -7, H board
- WHT/BLU → To (4) -7, H board
- GRN → To (2) -4, I board
- WHT/GRN → To (2) -1, I board
- WHT → To (5) -9, H board
- WHT → To (4) -9, H board
- YEL → To (8) -2, G board
- WHT/YEL → To (8) -17, G board
- BRN → To C1001(+)
- BRN → To C1001(+)
- BLK → To ground, C1001
- BLK → To ground, C1001
- VIO → To C1001(-)
- VIO → To C1001(-)
- WHT → To L-CH DIRECT SPEAKER terminal
- RED → To R-CH DIRECT SPEAKER terminal

※

Q717~719	R725, 775	R731, 781	A	B
Q720~722		R732, 782		
2SK60 } -53	33k	1.8k	-9.4V~-11.9V	9.4V~11.9V
2SJ18 } -54	33k	1.5k	-11.9V~-14.4V	11.9V~14.4V
	33k	1.2k	-14.4V~-16.9V	14.4V~16.9V
	30k	1.0k	-16.9V~-19.4V	16.9V~19.4V
	30k	1.0k	-19.4V~-21.9V	19.4V~21.9V
	30k	820	-21.9V~-24.4V	21.9V~24.4V

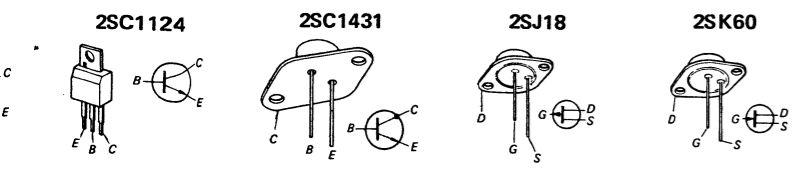
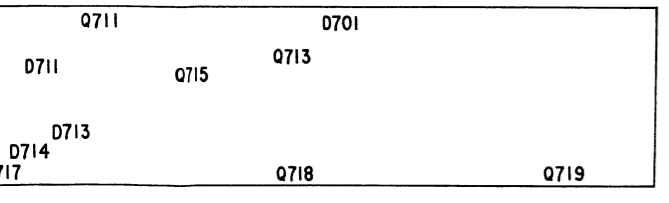





4-11. MOUNTING DIAGRAM - G Board CLASS A POWER AMP -

- Conductor Side -

USA Model only: Up to Serial No. 800,140

Semiconductor Location

Q604	Q607	D602	Q631	D603	Q605	D601	Q655	D653	D652			
	D604	Q606	Q603	Q602	Q601	Q651	Q652	Q653	Q656	Q657	Q654	D654

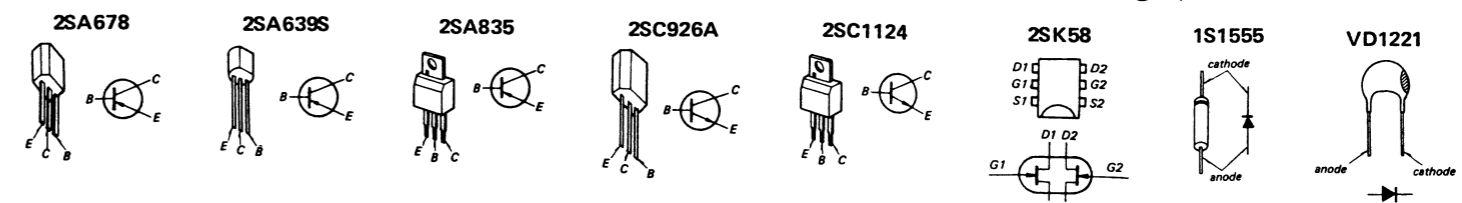
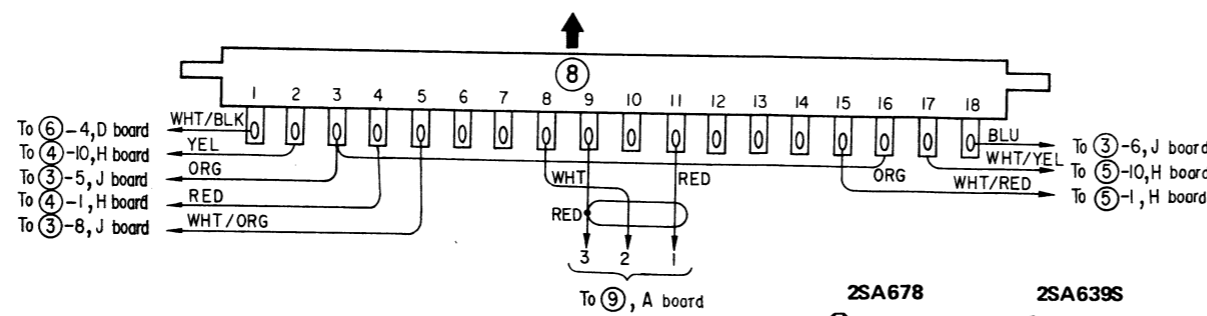
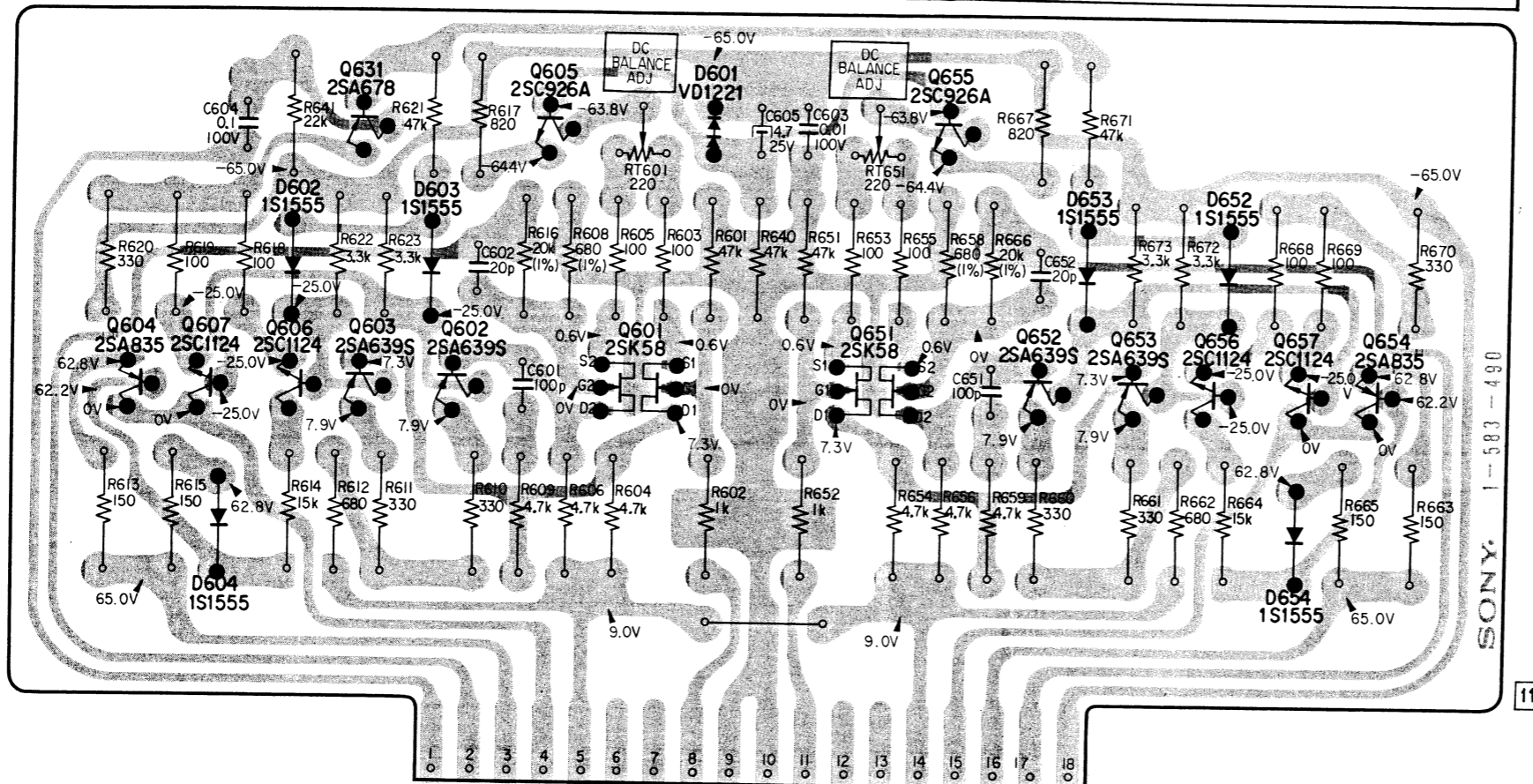

USA Model: Serial No. 800,141 and later  
 UK Model: Serial No. 600,001 and later  
 AEP Model: Serial No. 500,001 and later  
 E Model: Serial No. 400,001 and later

Semiconductor Location

Q604	Q607	D602	Q631	D603	Q605	D601	Q655	D653	D652			
	D604	Q606	Q603	Q602	Q601	Q651	Q652	Q653	Q656	Q657	Q654	D654

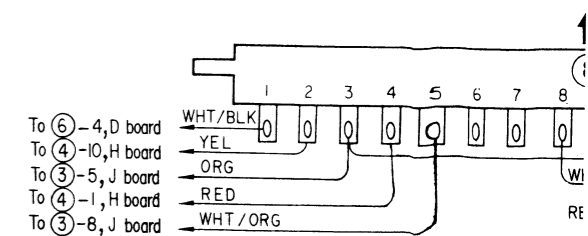
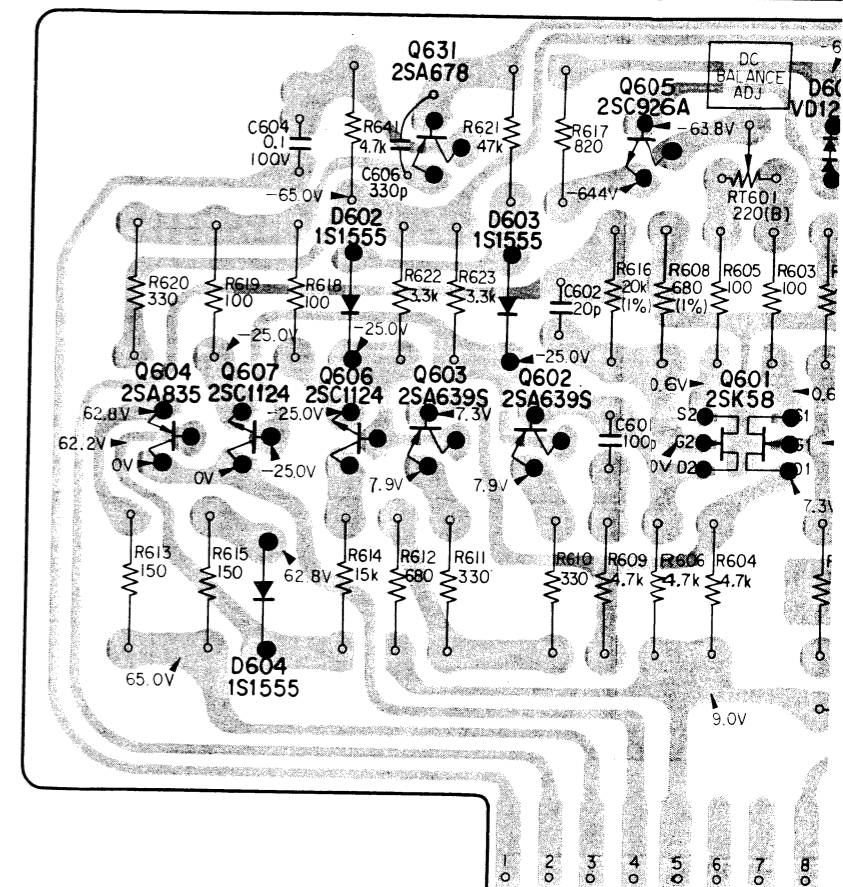

USA Model: Serial No. 800,141 and later  
 UK Model: Serial No. 600,001 and later  
 AEP Model: Serial No. 500,001 and later  
 E Model: Serial No. 400,001 and later

Semiconductor Location

Q604	Q607	D602	Q631	D603	Q605	D601	Q655	D653	D652	Q657	Q654
	D604	Q606	Q603	Q602	Q601	Q651	Q652	Q653	Q656	D654	

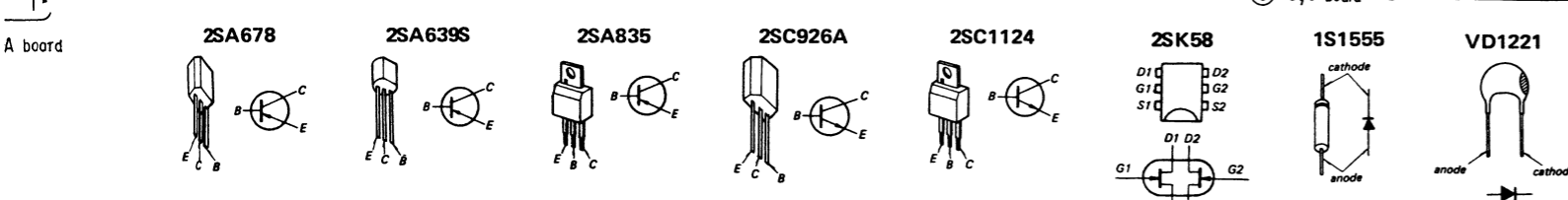
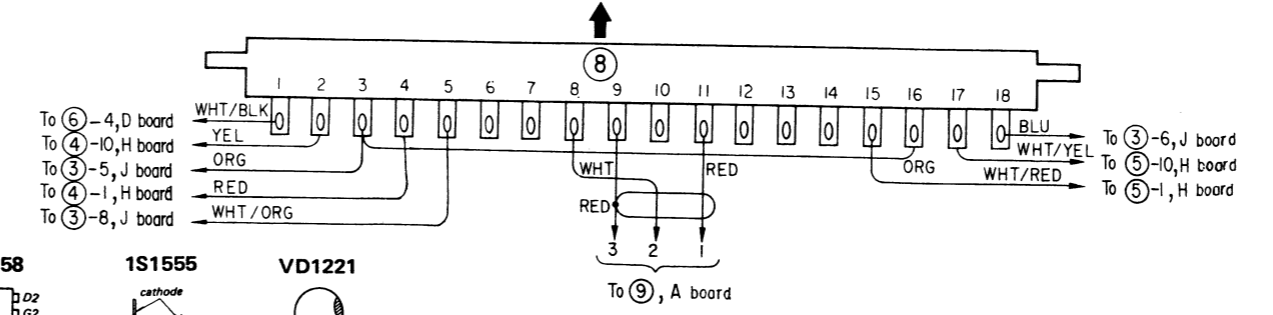
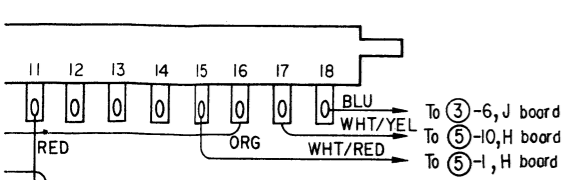
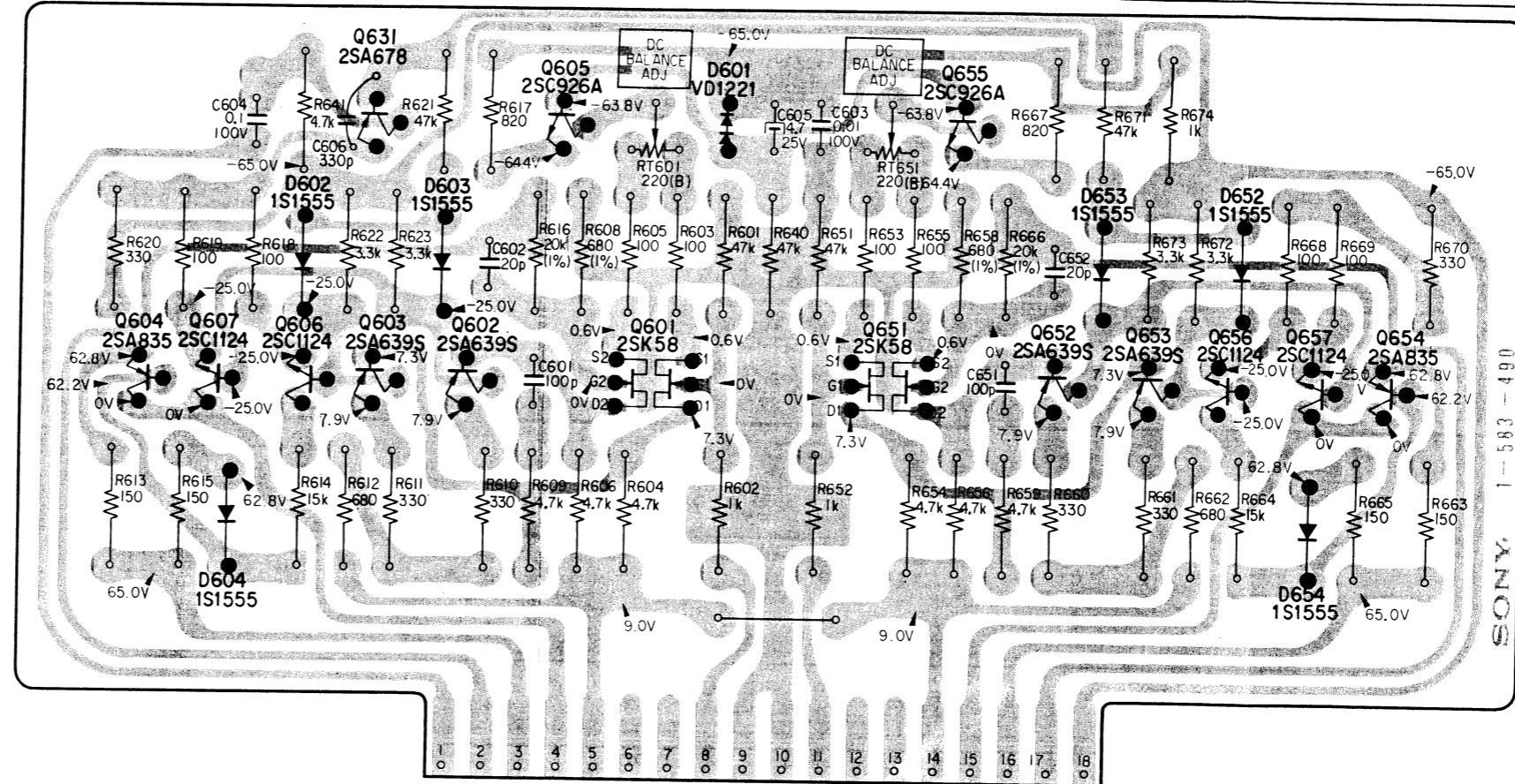
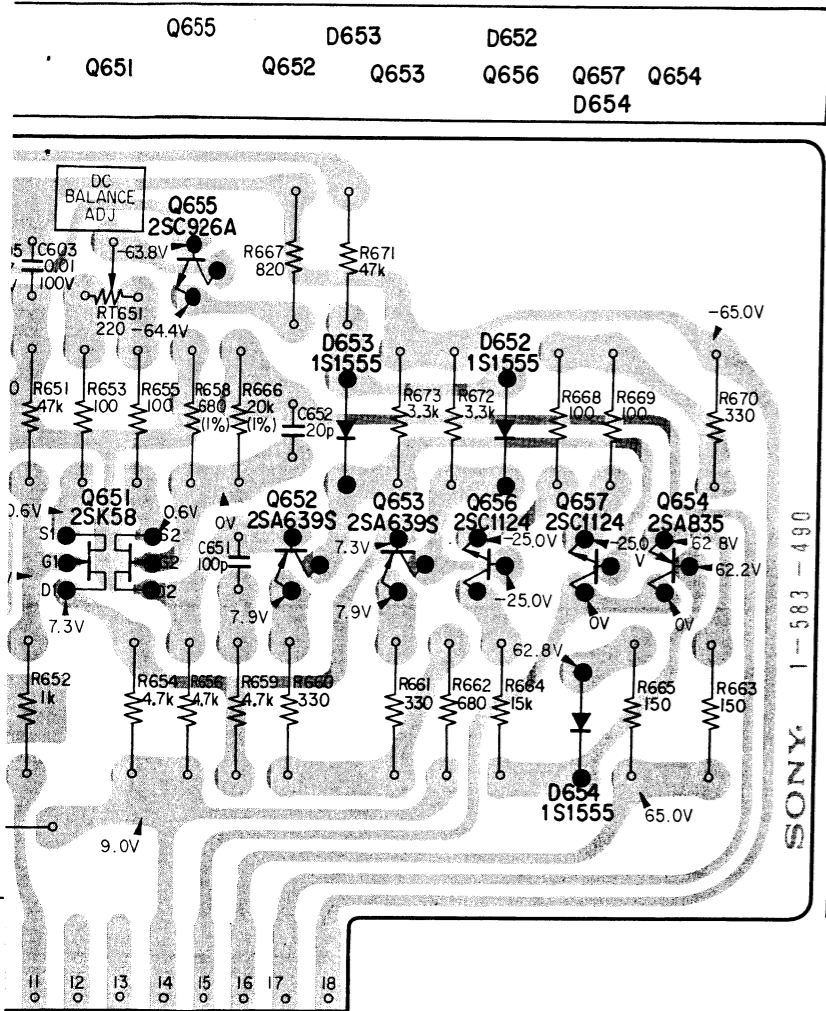



4-12. MOUNTING DIAGRAM — I Board POWER SUPPLY A —

— Conductor Side —

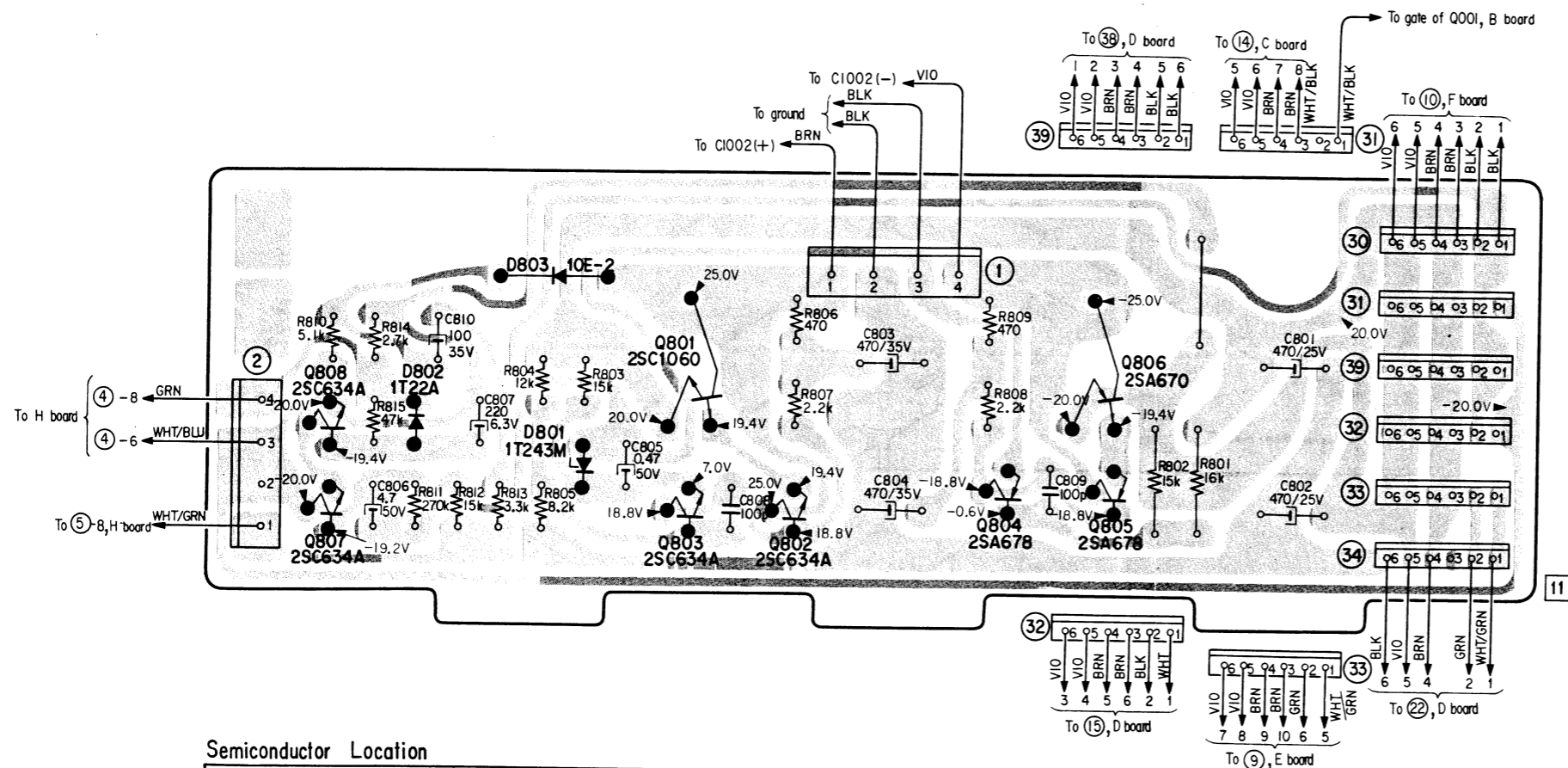

Semiconductor Location

Q808	D802	D803	Q801	Q806
Q807		D801	Q803	Q802
			Q804	Q805

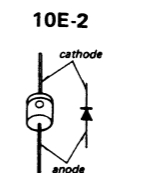
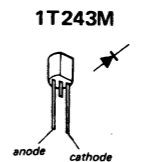
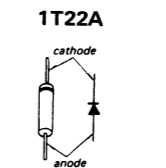
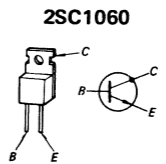
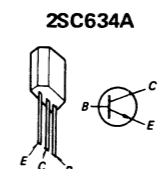
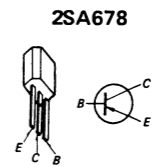
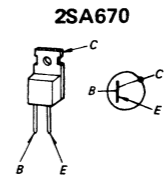

SECTION 5  
EXPLODED VIEWS

(1)

-Hardware Nomenclature-

<b>P</b>	- Pan Head Screw	
<b>PS</b>	- Pan Head Screw with Spring Washer	
<b>K</b>	- Flat Countersunk Head Screw	
<b>B</b>	- Binding Head Screw	
<b>RK</b>	- Oval Countersunk Head Screw	
<b>T</b>	- Truss Head Screw	
<b>R</b>	- Round Head Screw	
<b>F</b>	- Flat Fillister Head Screw	
<b>SC</b>	- Set Screw	
<b>E</b>	- Retaining Ring (E Washer)	
	W - Washer	
	SW - Spring Washer	
	LW - Lock Washer	
	N - Nut	

- Example -

Type of Slot  
 ⊕ P 3x10  
 Length in mm (L)  
 Diameter in mm (D)  
 Type of Head

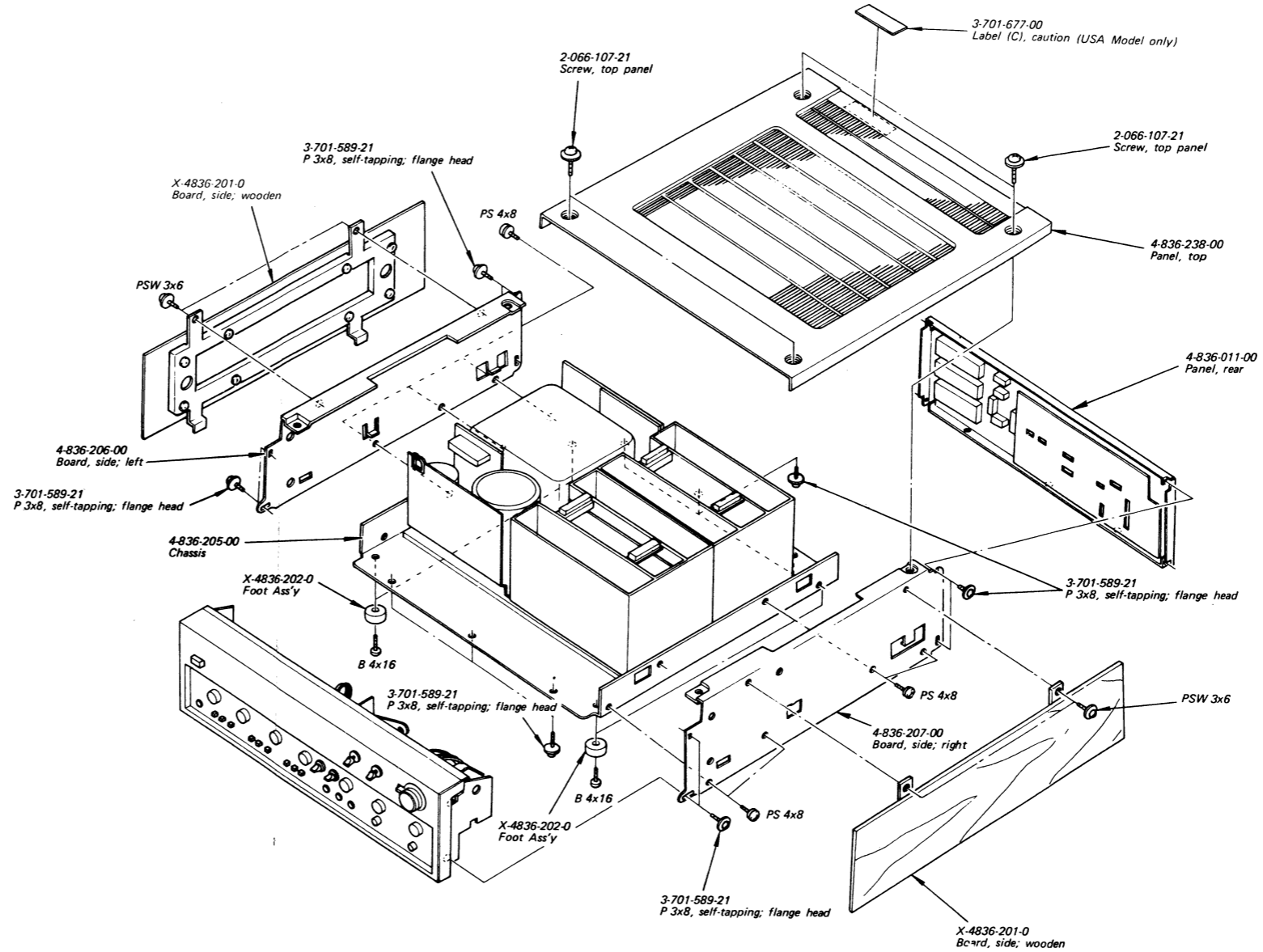

**Note:**

- Items without part number and description are not available.
- All screws are Phillips (cross recess) type unless otherwise noted.
- (-) = slotted head
- "PPT" type screws may be replaced with "B" type screws.

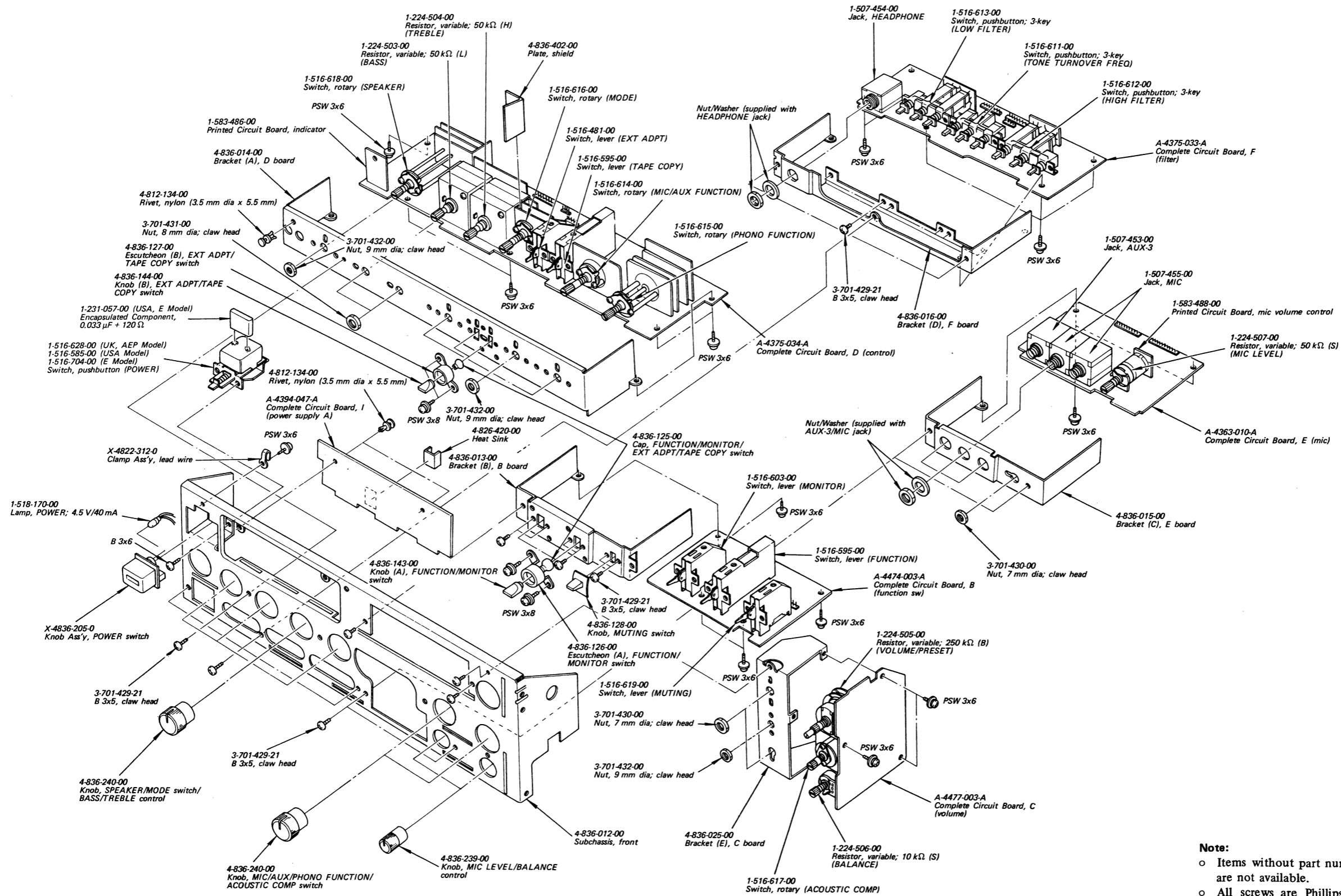

**Note:**

- Items without part number and description are not available.
- All screws are Phillips (cross recess) type unless otherwise noted.
- (-)= slotted head
- "PPT" type screws may be replaced with "B" type screws.

(3)

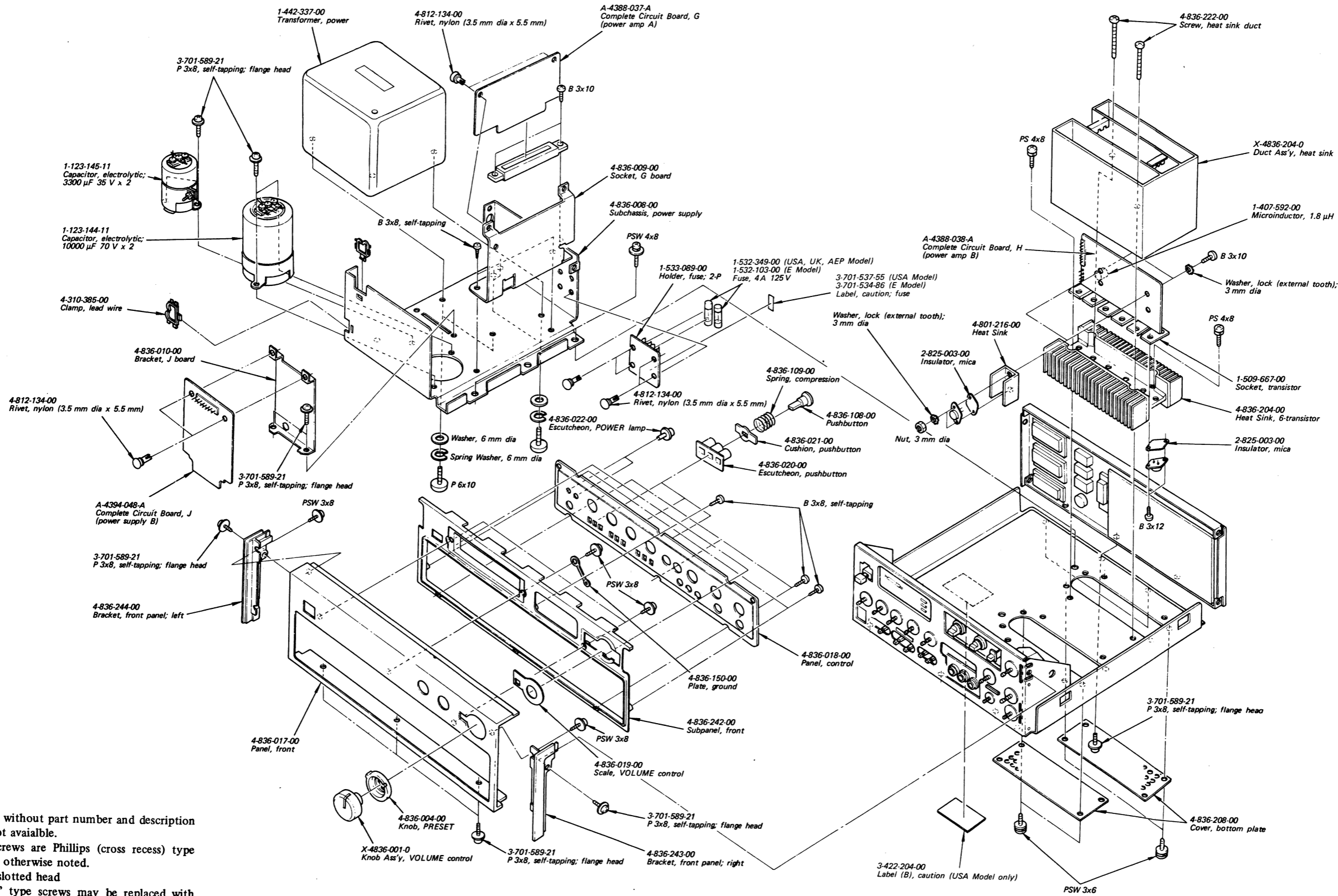

**Note:**

- Items without part number and description are not available.
- All screws are Phillips (cross recess) type unless otherwise noted.  
(-) = slotted head
- "PPT" type screws may be replaced with "B" type screws.

Ref. No.	Part No.	Description
IC401	IC	BX-270
IC402	IC	BX-270
D101	Diode	1T243M
D102	Diode	1T243M
D103	Diode	1S1555
D104	Diode	TLR109
D105	Diode	TLR109
D201~D208	Diode	1S1555
D601	Diode	VD1221
D602~D604 (D652~D654)	Diode	1S1555
D701(D751)	Diode	VD1221
D702(D752)	Diode	VD1221
D703(D753)	Diode	1S1555
D704(D754)	Diode	5P2M
D705~D708 (D755~D758)	Diode	UO-5E
D709~D711 (D759~D761)	Diode	1S1555
D712(D762)	Diode	SH-1S
D713(D763)	Diode	SH-1S
D714(D764)	Diode	1T22A
D715(D765)	Diode	1T22A
D716(D766)	Diode	VD1221
D801	Diode	1T243M
D802	Diode	1T22A
D803	Diode	10D-2
D901	Diode	10D-2
D902	Diode	S5151
D903	Diode	S5151R
D904~D908	Diode	10D-2
D910	Diode	1T243M
D911	Diode	VD1221
D912	Diode	1T243M
Pth701 (Pth751)	1-800-340-21	Posistor

Ref. No.	Part No.	Description
<b>TRANSFORMER AND INDUCTORS</b>		
L701(L751)	1-407-592-00	Microinductor, 1.8 μH
PT1	1-442-337-00	Transformer, power
<b>CAPACITORS</b>		
Capacitors listed here are 50 V mylar type unless otherwise specified and in μF except as indicated with p (p means μμ). elect = electrolytic		
C101(C151)	1-131-192-11	4.7 10V tantalum
C102(C152)	1-102-978-11	220p 50V ceramic
C103(C153)	1-131-192-11	4.7 10V tantalum
C104(C154)	1-101-880-11	47p 50V ceramic
C105(C155)	1-121-927-11	47 10V elect
C106(C156)	1-105-522-12	0.056
C107(C157)	1-129-701-11	0.01 100V film
C108(C158)	1-101-880-11	47p 50V ceramic
C109(C159)	1-121-927-11	47 10V elect
C110(C160)	1-121-927-11	47 10V elect
C111(C161)	1-105-505-12	0.0022
C112(C162)	1-105-505-12	0.0022
C113~C115 (C163~C165)	1-105-520-12	0.039
C116(C166)	1-121-927-11	47 10V elect
C117(C167)	1-101-880-11	47p 50V ceramic
C121~C124	1-121-352-11	47 10V elect
C125	1-121-912-11	1 50V elect
C126	1-121-912-11	1 50V elect
C127~C130	1-121-398-11	10 25V elect
C131	1-105-661-12	0.001
C132	1-102-978-11	220p 50V ceramic
C133	1-102-973-11	100p 50V ceramic
C201(C251)	1-121-913-11	3.3 25V elect
C202(C252)	1-121-927-11	47 10V elect
C203(C253)	1-105-661-12	0.001
C204(C254)	1-105-661-12	0.001
C205(C255)	1-102-953-11	18p 50V ceramic
C206(C256)	1-121-913-11	3.3 25V elect
C207(C257)	1-102-816-11	120p 50V ceramic
C210	1-121-927-11	47 10V elect

Ref. No.	Part No.	Description
C301(C351)	1-121-927-11	47 10V elect
C302(C352)	1-121-916-11	10 16V elect
C303(C353)	1-102-973-11	100p 50V ceramic
C304(C354)	1-105-683-12	0.068
C305(C355)	1-105-687-12	0.15
C306(C356)	1-105-661-12	0.001
C307(C357)	1-105-679-12	0.033
C308(C358)	1-105-665-12	0.0022
C309(C359)	1-101-880-11	47p 50V ceramic
C401(C451)	1-105-667-12	0.0033
C402(C452)	1-105-663-12	0.0015
C403(C453)	1-102-116-11	680p 50V ceramic
C404(C454)	1-105-663-12	0.0015
C405(C455)	1-121-927-11	47 10V elect
C406(C456)	1-105-685-12	0.1
C407(C457)	1-105-680-12	0.039
C408(C458)	1-121-927-11	47 10V elect
C409(C459)	1-105-687-12	0.15
C410(C460)	1-105-691-12	0.33
C411	1-121-398-11	10 25V elect
C412	1-121-398-11	10 25V elect
C413	1-121-726-11	0.47 50V elect
C601(C651)	1-102-973-11	100p 50V ceramic
C602(C652)	1-102-958-11	20p 50V ceramic
C603	1-105-713-12	0.01 100V
C604	1-105-725-12	0.1 100V
C605	1-121-395-11	4.7 25V elect
C701(C751)	1-121-398-11	10 25V elect
C702(C752)	1-105-661-12	0.001
C703(C753)	1-105-661-12	0.001
C704(C754)	1-105-661-12	0.001
C705(C755)	1-102-816-11	120p 50V ceramic
C706(C756)	1-102-816-11	120p 50V ceramic
C707(C757)	1-121-419-11	220 6.3V elect
C708(C758)	1-102-964-11	36p 50V ceramic
C709(C759)	1-105-661-12	0.001
C710(C760)	1-105-661-12	0.001
C711(C761)	1-105-661-12	0.001
C712(C762)	1-105-679-12	0.033
C713(C763)	1-105-685-12	0.1

Ref. No.	Part No.	Description
C714(C764)	1-105-725-12	0.1 100V
C715(C765)	1-105-725-12	0.1 100V
C716(C766)	1-105-725-12	0.1 100V
C717(C767)	1-105-725-12	0.1 100V
C801	1-121-940-11	470 25V elect
C802	1-121-940-11	470 25V elect
C803	1-121-941-11	470 35V elect
C804	1-121-941-11	470 35V elect
C805	1-121-726-11	0.47 50V elect
C806	1-121-396-11	4.7 50V elect
C807	1-121-419-11	220 6.3V elect
C808	1-102-973-11	100p 50V ceramic
C809	1-102-973-11	100p 50V ceramic
C810	1-123-062-11	100 35V elect
C901	1-105-725-12	0.1 100V
C902	1-105-725-12	0.1 100V
C903	1-121-726-11	0.47 50V elect
C904	1-105-713-12	0.01 100V
C905	1-102-355-11	0.01/0.01 500V ceramic
C906	1-102-355-11	0.01/0.01 500V ceramic
C907	1-105-713-12	0.01 100V
C908	1-102-355-11	0.01/0.01 500V ceramic
C909	1-102-355-11	0.01/0.01 500V ceramic
C910	1-121-941-11	470 35V elect
C911	1-121-941-11	470 35V elect
C912	1-121-726-11	0.47 50V elect
C913	1-105-713-12	0.01 100V
C914	1-105-713-12	0.01 100V
C1001	1-123-144-11	10,000/10,000 70V elect
C1002	1-123-145-11	3,000/3,000 35V elect

**RESISTORS**

All resistors are in Ω. ¼W, ±5%, carbon resistors (except particular type) are omitted. Check schematic diagram for the resistance values. k = 1000, M = 100 k

R110(R160)	1-212-534-21	1.1 k	±1%	metal-oxide
R111(R161)	1-212-530-21	750	±1%	metal-oxide

Ref. No.	Part No.	Description
R112(R162)	1-212-669-21	4.3k ±1% metal-oxide
R113(R163)	1-212-696-21	56k ±1% metal-oxide
R114(R164)	1-212-675-21	7.5k ±1% metal-oxide
R117(R167)	1-212-540-21	2k ±1% metal-oxide
R118(R168)	1-212-684-21	18k ±1% metal-oxide
R128(R178)	1-212-684-21	18k ±1% metal-oxide
R129(R179)	1-212-540-21	2k ±1% metal-oxide
R608(R658)	1-212-529-21	680 ±1% metal-oxide
R613(R663)	1-211-526-11	150 (nonflammable)
R615(R665)	1-211-526-11	150 (nonflammable)
R616(R666)	1-212-685-21	20k ±1% metal-oxide
R619(R669)	1-211-522-11	100 (nonflammable)
R620(R670)	1-211-534-11	330 (nonflammable)
R674	1-211-935-11	1k (nonflammable)
R725(R775)	1-206-699-11	30k 2W metal-oxide
R729(R779)	1-211-534-11	330 (nonflammable)
R730(R780)	1-211-534-11	330 (nonflammable)
R733(R783)	1-211-534-11	330 (nonflammable)
R734(R784)	1-211-534-11	330 (nonflammable)
R737(R787)	1-206-676-11	3.3k 2W metal-oxide
R738~R741	1-217-158-11	0.47 5W metal
(R788~R791)		
R742(R792)		
R743(R793)	1-202-525-11	10 ½W composition
R903	1-212-698-21	68k ±1% metal-oxide
R904	1-212-680-21	12k ±1% metal-oxide
R910	1-211-490-11	4.7 (nonflammable)
R911	1-211-490-11	4.7 (nonflammable)
R912	1-211-498-11	10 (nonflammable)
R913	1-211-498-11	10 (nonflammable)
RT601 (RT651)	1-224-487-00	200, adjustable (dc balance adj.)
RT701 (RT751)	1-224-491-00	22k, adjustable (dc bias adj.)
RV021~RV023 (RV071~RV073)	1-224-498-00	100k (B), variable (LEVEL ADJ)

Ref. No.	Part No.	Description
RV101 (RV151)	1-224-504-00	50k (H), variable (TREBLE)
RV102 (RV152)	1-224-503-00	50k (L), variable (BASS)
RV201 (RV251)	1-224-507-00	50k (S), variable (MIC LEVEL)
RV301 (RV351)	1-224-505-00	250k (B), variable (VOLUME/PRESET)
RV302 (RV352)	1-224-506-00	10k (S), variable (BALANCE)
<b>SWITCHES</b>		
S1	1-516-081-00	Slide (IMPEDANCE)
S2	1-516-614-00	Rotary (MIC/AUX FUNCTION)
S3	1-516-595-00	Lever/Slide (FUNCTION)
S4	1-516-603-00	Lever/Slide (MONITOR)
S5	1-516-481-00	Lever/Slide (EXT ADPT)
S6	1-516-595-00	Lever/Slide (TAPE COPY)
S7	1-516-615-00	Rotary (PHONO FUNCTION)
S8	1-516-616-00	Rotary (MODE)
S9	1-516-617-00	Rotary (ACOUSTIC COMP)
S10~S12	1-516-612-00	Pushbutton, 3-key (HIGH FILTER)
S13~S15	1-516-611-00	Pushbutton, 3-key (TONE, TURNOVER FREQ)
S16~S18	1-516-613-00	Pushbutton, 3-key (LOW FILTER)
S19	1-516-619-00	Lever/Slide (MUTING)
S20	1-516-081-00	Slide (PRE/POWER AMP)
S21	1-516-618-00	Rotary (SPEAKER)
S22	1-516-704-00	Pushbutton (POWER) (E Model)
	1-516-585-00	Pushbutton (POWER) (USA Model)
	1-516-628-00	Pushbutton (POWER) (UK, AEP Model)
<b>MISCELLANEOUS</b>		
CNJ1~CNJ3	1-509-403-00	Outlet, ac (USA, E Model)
CNJ1	1-509-546-00	Connector, ac input, 3-P (UK, AEP Model)
CNP1	1-534-819-00	Cord, power (UK Model)
	1-534-754-00	Cord, power (AEP Model)
	1-534-993-00	Cord, power (E Model)
	1-534-992-00	Cord, power (USA Model)
CPI	1-231-057-00	Encapsulated Component, 0.033µF + 120Ω (USA, E Model)
F1,F2	1-532-103-00	Fuse, 125V/4A (E Model)
	1-532-349-00	Fuse, 125V/4A (USA, UK, AEP Model)

Ref. No.	Part No.	Description
J101(J201)	1-507-416-00	Jack, phono; 4-P
J102(J202)		
J103(J203)	1-536-352-00	Jack, phono; 4-P
J105(J205)		
J104(J204)	1-507-385-00	Jack, phono; 2-P
J106~J113 (J206~J213)	1-507-416-00	Jack, phono; 4-P
J301	1-507-453-00	Jack, AUX-3
J302,J303	1-507-455-00	Jack, MIC
J304	1-507-454-00	Jack, HEADPHONE
PL1	1-518-170-00	Lamp, POWER; 4.5 V/40 mA
TM1~TM3	1-535-090-00	Binding Post, 4 unit (SPEAKER)
VS	1-526-520-11	Selector, voltage
	1-508-648-00	Connector, 4-P (male)
	1-508-651-00	Connector, 10-P (male)
	1-508-652-00	Connector, 8-P (male)
	1-508-684-00	Connector, 2-P (male)
	1-508-693-00	Connector, 10-P (male)
	1-508-694-00	Connector, 8-P (male)
	1-508-695-00	Connector, 6-P (male)
	1-508-696-00	Connector, 4-P (male)
	1-509-667-00	Socket, transistor
	1-533-089-00	Holder, fuse; 2-P
	1-536-354-00	Pin, terminal

Part No.	Description
<b>PACKING MATERIALS AND ACCESSORIES</b>	
0-591-219-01	Note, instruction manual (E Model only)
1-506-113-00	Plug, shorting
1-534-514-13	Cord, connection (RK-81)
2-057-975-00	Bag, polyethylene; accessories
3-701-020-00	Bag, polyethylene; instruction manual
3-780-445-22	Manual, instruction
3-793-793-00	Sheet, check
3-793-794-00	Cover, instruction manual
3-793-796-21	Diagram, signal flow
3-701-300-00	Bag, polyethylene; unit
4-836-024-00	Carton
4-836-257-00	Cushion, side
4-836-258-00	Cushion, lower
4-836-259-00	Cushion
X-3701-029-0	Card Ass'y, warranty (USA Model only)
1-506-138-11	Plug, phono (red) (USA Model only)
1-506-138-12	Plug, phono (white) (USA Model only)
3-701-730-00	Bag, polyethylene; IBM card (USA Model only)
3-701-742-00	Card, IBM (USA Model only)



(4)

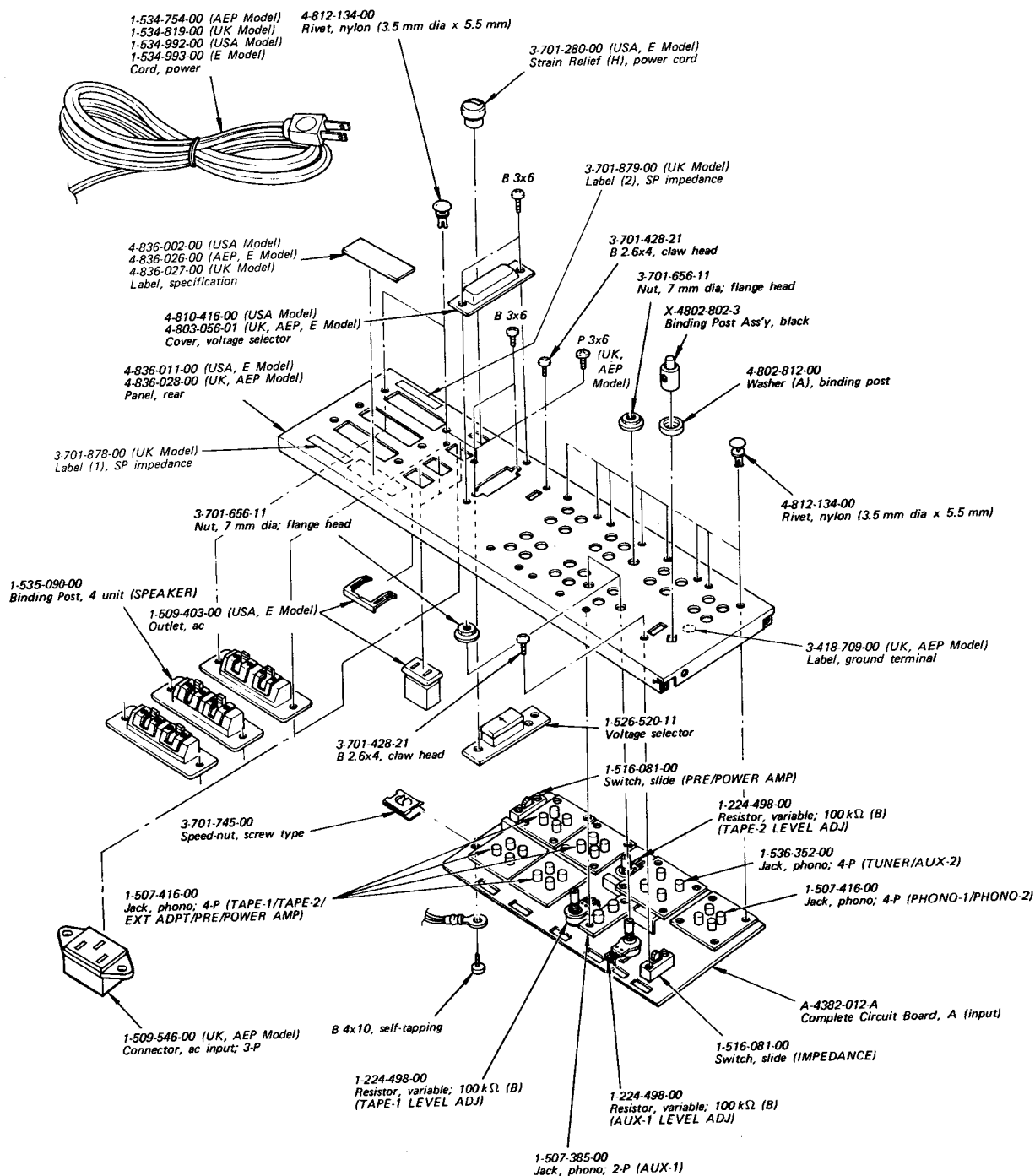

- Note:**
- Items without part number and description are not available.
  - All screws are Phillips (cross recess) type unless otherwise noted.
  - (-) = slotted head
  - "PPT" type screws may be replaced with "B" type screws.

**SECTION 6  
ELECTRICAL PARTS LIST**

<u>Ref. No.</u>	<u>Part No.</u>	<u>Description</u>	<u>Ref. No.</u>	<u>Part No.</u>	<u>Description</u>
<b>CIRCUIT BOARDS</b>			Q701(Q751)	Transistor	2SA678
			Q702(Q752)	Transistor	2SA634A
A-4382-012-A	A	(input), complete	Q703(Q753)	Transistor	2SC634A
A-4474-003-A	B	(function switch), complete	Q704(Q754)	Transistor	2SA678
A-4477-003-A	C	(volume), complete	Q705(Q755)	Transistor	2SC634A
A-4375-034-A	D	(control), complete	Q706(Q756)	Transistor	2SA678
A-4363-010-A	E	(mic), complete	Q707(Q757)	Transistor	2SA639S
A-4375-033-A	F	(filter), complete	Q708(Q758)	Transistor	2SC926A
A-4388-037-A	G	(power amp (A)), complete	Q709(Q759)	Transistor	2SC926A
A-4388-038-A	H	(power amp (B)), complete	Q710(Q760)	Transistor	2SA639S
A-4394-047-A	I	(power supply (A)), complete	Q711(Q761)	Transistor	2SC1124
A-4394-048-A	J	(power supply (B)), complete	Q712(Q762)	Transistor	2SA678
1-583-486-00	Indicator		Q713(Q763)	Transistor	2SA835
1-583-488-00	Mic Amp		Q714(Q764)	Transistor	2SC1124
			Q715(Q765)	Transistor	2SC1431
			Q716(Q766)	Transistor	2SA762
			Q717~Q719 (Q767~Q769)	FET	2SK60
			Q720~Q722 (Q770~Q772)	FET	2SJ18
<b>SEMICONDUCTORS</b>			Q801	Transistor	2SC1060
Q001(Q051)	FET	2SK43	Q802	Transistor	2SC634A
Q002(Q052)	FET	2SK43	Q803	Transistor	2SC634A
Q101	Transistor	2SC1637	Q804	Transistor	2SA678
Q102	Transistor	2SA705	Q805	Transistor	2SA678
Q103	Transistor	2SA705	Q806	Transistor	2SA670
Q104	FET	2SK43	Q807	Transistor	2SC634A
Q105	Transistor	2SC634A	Q808	Transistor	2SC634A
Q106	Transistor	2SA678	Q901	Transistor	2SA671
Q107	Transistor	2SA678	Q902	Transistor	2SC1061
Q108~Q112	Transistor	2SC634A	Q903	Transistor	2SC634A
Q151	Transistor	2SC1637	Q904	Transistor	2SA678
Q152	Transistor	2SA705	Q905	Transistor	2SA671
Q153	Transistor	2SA705	IC101	IC	BX-269
Q154	FET	2SK43	IC102	IC	CX-0461
Q601(Q651)	FET	2SK58	IC103	IC	BX-270
Q602(Q652)	Transistor	2SA639S	IC104	IC	BX-269
Q603(Q653)	Transistor	2SA639S	IC201	IC	CX-0461
Q604(Q654)	Transistor	1S1555	IC301	IC	BX-270
Q605(Q655)	Transistor	2SC926A			
Q606(Q656)	Transistor	2SC1124			
Q607(Q657)	Transistor	2SC1124			
Q631	Transistor	2SA678			