

TA-A77E/D709E

SERVICE MANUAL REVISED

AEP Model
UK Model

TA-D709E

E Model
Australian Model
Tourist Model

TA-A77E



This set is the Preamplifier section in LBT-A77CD/A77CDM/D709CD/D759CD.

This photo is TA-A77E.

SPECIFICATIONS

Input	Jack type	Sensitivity	Impedance
VIDEO 1/MD	Phono	245 mV	47 kohms
VIDEO 2	Phono	245 mV	47 kohms
VIDEO 3	Phono	245 mV	47 kohms
PHONO (MM)	Phono	3.3 mV	47 kohms
MIC	Phone	1 mV	10 kohms

Audio output	Jack type	Voltage	Impedance
VIDEO 1/MD	Phono	235 mV	2 kohms
VIDEO 2	Phono	235 mV	2 kohms
CENTER OUT	Phono		

Video output (phono jacks)	
VIDEO 1/MD	1 Vp-p, 75 ohm unbalanced, sync negative
VIDEO 2	1 Vp-p, 75 ohm unbalanced, sync negative
MONITOR	1 Vp-p, 75 ohm unbalanced, sync negative
Frequency response	15 Hz to 20 kHz $+0$ dB -3 dB
Power requirements	220—230V AC, 50/60Hz (AEP, G, IT, EE model) 240V AC, 50/60Hz (UK model) 120V/220—240V AC, adjustable with the voltage selector, 50/60Hz (A77E)
Power consumption	15 W
Mass	Approx. 3.7 kg (8 lbs 3 oz)
Dimensions	Approx. 355 x 135 x 330 mm (14 x 5 $\frac{1}{4}$ x 12 $\frac{7}{8}$ inches) (w/h/d, including projections)

Design and specifications are subject to change without notice.

Note

This appliance conforms with EEC Directive 87/308/EEC regarding interference suppression.

• Abbreviations

G : German model
IT : Italian model
EE: East European model

Dolby noise reduction and HX Pro headroom extension manufactured under license from Dolby Laboratories Licensing Corporation. HX Pro originated by Bang & Olufsen. "DOLBY", the double-D symbol \square and "HX PRO" are trademarks of Dolby Laboratories Licensing Corporation.

SAFETY-RELATED COMPONENT WARNING!!

COMPONENTS IDENTIFIED BY MARK \triangle OR DOTTED LINE WITH MARK \triangle ON THE SCHEMATIC DIAGRAMS AND IN THE PARTS LIST ARE CRITICAL TO SAFE OPERATION. REPLACE THESE COMPONENTS WITH SONY PARTS WHOSE PART NUMBERS APPEAR AS SHOWN IN THIS MANUAL OR IN SUPPLEMENTS PUBLISHED BY SONY.

DIGITAL STEREO PREAMPLIFIER
SONY[®]

MODEL IDENTIFICATION

—Specification Label—

AEP, UK, G, IT, EE model : TA-D709E
E, EA, AUS, JE, MY, SP model: TA-A77E

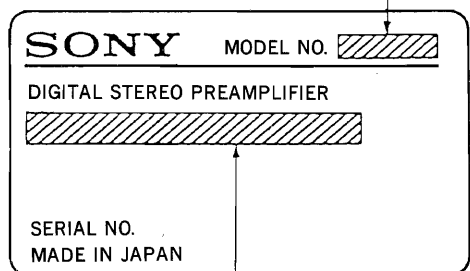

AEP, IT, EE model: AC: 220V—230V~50/60Hz 15W

UK model : AC: 240V~50/60Hz

G model : SYSTEM LBT-D709

AC: 220V—230V~50/60Hz 15W

AUS, E, JE,

MY, SP, EA model: AC: 110V—120V/220V—240V~50/60Hz 15W

• Abbreviations

- G : German model
- IT : Italian model
- EE : East European model
- EA : Saudi Arabia model
- AUS: Australian model
- JE : Tourist model
- MY : Malaysia model
- SP : Singapore model

TABLE OF CONTENTS

<u>Section</u>	<u>Title</u>	<u>Page</u>
1. GENERAL		
1-1.	Location of Controls	3
2. SERVICE NOTES		
2-1.	Notes at Service and Inspection	4
2-2.	Removal of Joint	4
3. DIAGRAMS		
3-1.	Pin Description	5
3-2.	Circuit Boards Location	7
3-3.	Semiconductor Lead Layouts	8
3-4.	Block Diagram	12
3-5.	Printed Wiring Boards —Main Section (TYPE I)—	15
3-6.	Schematic Diagram —Main Section (TYPE I)— ..	19
3-7.	Schematic Diagram —Panel Section (TYPE I)— ..	24
3-8.	Printed Wiring Boards —Panel Section (TYPE I)—	29
3-9.	Printed Wiring Boards —Panel Section (TYPE II)—	31
3-10.	Schematic Diagram —Panel Section (TYPE II)— ..	33
3-11.	Schematic Diagram —Main Section (TYPE II)— ..	38
3-12.	Printed Wiring Boards —Main Section (TYPE II)—	43
3-13.	Printed Wiring Boards —Main Section (TYPE III)—	47
3-14.	Schematic Diagram —Main Section (TYPE III)— ..	51
3-15.	Schematic Diagram —Panel Section (TYPE III)— ..	56
3-16.	Printed Wiring Boards —Panel Section (TYPE III)—	61
3-17.	Printed Wiring Boards —Panel Section (TYPE IV)—	63
3-18.	Schematic Diagram —Panel Section (TYPE IV)— ..	65
3-19.	Schematic Diagram —Main Section (TYPE IV)— ..	70
3-20.	Printed Wiring Boards —Main Section (TYPE IV)—	75
4. EXPLODED VIEWS		
4-1.	Front Panel Section	79
4-2.	Chassis Section	80
5. ELECTRICAL PARTS LIST		81

SECTION 1 GENERAL

This section is extracted from instruction manual.

1-1. LOCATION OF CONTROLS

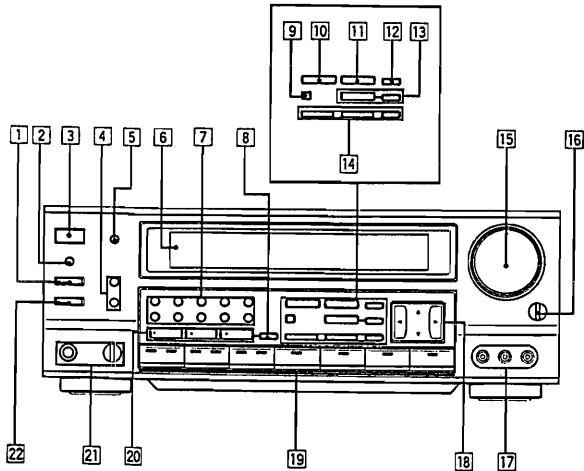

- 1 EFFECT button and indicator (22)
- 2 KARAOKE PON button and indicator (150) (A77E only)
- 3 POWER switch (18)
- 4 Dynamic Bass System controls (FREQUENCY, LEVEL) (22)
- 5 DISPLAY button (136)
- 6 Display window
- 7 Numeric buttons (124, 140, 142)
- 8 MEMORY button (140)
- 9 PRO LOGIC MODE button (120)
- 10 EFFECT LEVEL button (124)
- 11 ACOUSTIC CONTROL button (122, 130, 138)
- 12 CHARACTER EDIT button (144)
- 13 SURROUND CONTROL and ON/OFF buttons (130)
- 14 EQUALIZER BAND, SLOPE and FLAT buttons (132, 134)
- 15 VOLUME control (22)
- 16 BALANCE control (22)
- 17 VIDEO 3 INPUT jacks (14)
- 18 CURSOR CONTROL button (122, 130, 132, 138, 144)
- 19 Function selectors and indicators (42)
- 20 SELECT 10, MORE 10 and P. FILE buttons (124, 142)
- 21 MIC (microphone) jack and MIC LEVEL control (152)
- 22 P. FUNCTION button and indicator (156)

SECTION 2 SERVICE NOTES

2-1. NOTES AT SERVICE AND INSPECTION

The parts No. suffix of the board differs from set to set.
There are four types of parts No. suffix for each board.
Check the type of the set according to the following list before performing service and inspection.

Board Name	The Parts No. Suffix of the Board			
	TYPE I	TYPE II	TYPE III	TYPE IV
MAIN	11	12	13	14
MICROPHONE AMPLIFIER	11	11	12	13
VOL	12	14	15	16
BALANCE	11	11	11	12
VIDEO (3)	11	11	12	12
VIDEO FUNCTION	11	11	12	12
PANEL	11	12	12	13
AU FUNCTION	11	13	14	14

Note : Follow the disassembly procedure in the numerical order given.

2-2. REMOVAL OF JOINT

② Press the joint for front panel and remove it from POWER switch.

③ Remove the joint in the direction of arrow.

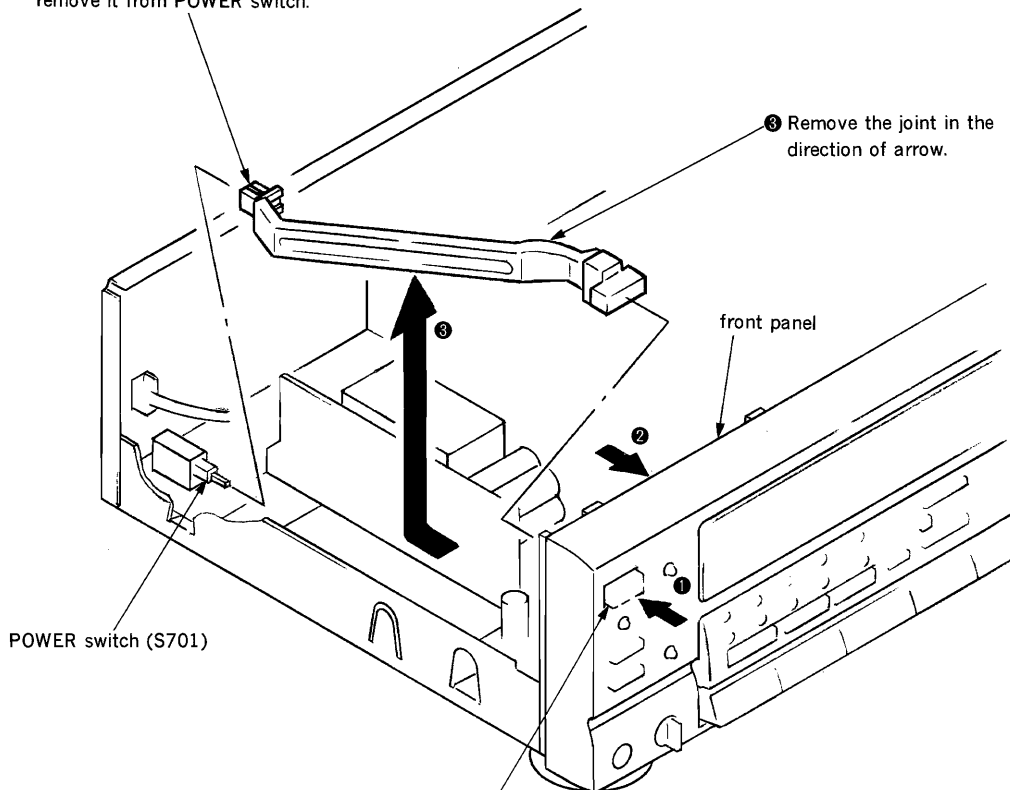

① Push the button (P) and POWER switch to turn ON.

SECTION 3 DIAGRAMS

3-1. PIN DESCRIPTION

• IC202 LC83015E (Digital Signal Processor)

Pin No.	Pin Name	I/O	Function
1—6	P0—P5	I/O	General purpose input/output ports (with pull-up resistor)
7	ASI1	I	Audio data serial input 1 pin
8	BCK1	I	Bit clock input pin used for ASI1 input (64fs or 32fs is applied).
9	FS384I	I	384fs or 512fs input pin.
10	LRCKI	I	L/R channel identification signal input pin (“H” for Lch ; “L” for Rch).
11	ASI2	I	Audio data serial input 2 pin
12	BCK2	I	Bit clock input pin for ASI2 input (64fs or 32fs is applied).
13	VDD1	—	+5V power pin
14—17	TEST1—TEST4	I	Pins used for tests, normally connected to GND.
18	VSS1	—	GND pin
19	TEST5	O	Output pin used for test, normally open.
20	$\overline{\text{RAS}}$	O	$\overline{\text{RAS}}$ signal output pin used for access to external DRAM.
21	$\overline{\text{CAS}}$	O	$\overline{\text{CAS}}$ signal output pin used for access to external DRAM.
22	$\overline{\text{DWRT}}$	O	Data write signal output pin used for access to external memory.
23	$\overline{\text{DREAD}}$	O	Data read signal output pin used for access to external memory.
24	$\overline{\text{CE/CS}}$	O	Chip enable signal output pin used for activating external SRAM or pseudo SRAM.
25—32	D7—D0	I/O	Data input/output pins used for communication with external memories (D0—D3 for one DRAM ; D0—D7 for two DRAMs or SRAM or pseudo SRAM).
33	VSS2	—	GND pin
34—50	A0—A16	O	External memory address output pin
51	VDD2	—	+5V power pin
52	OSC1	I	Oscillator input pin (connected to VDD or VSS when oscillator is not used).
53	OSC2	O	Oscillator output pin (open when oscillator is not used or external clock is used).
54	VSS3	—	GND pin
55	FS384O	O	384fs or 512fs output pin (through output of FS384I or self-run oscillating clock).
56	FS192O	O	192fs or 256fs output pin (1/2 frequency division output of FS384O).
57	FS128O	O	128fs output pin (1/3 or 1/4 frequency division output of FS384O).
58	FS64O	O	64fs or 32fs output pin (1/2 frequency division output of FS128O or through output of BCK1).
59	FS32O	O	32fs or 16fs output pin (1/2 frequency division output of FS64O).
60	LRCKO	O	1fs output pin (1/64 frequency division output of FS64O or through output of LRCKI)
61	AOWCK	O	2fs or 1fs output pin (1/32 frequency division output of FS64O).
62	ASO	O	Audio data serial output 1 pin
63	AOTDF1	O	Audio data serial output 2 pin
64	AOTDF2	O	Audio data serial output 3 pin
65	SI	I	Input pin for serial data from control micro computer (8 bit data).
66	SICK	I	Input pin for serial clock for SI.
67	$\overline{\text{SIRQ}}$	I	Serial input request signal input pin
68	$\overline{\text{SIACK}}$	O	Output pin for indicating that serial input being executed.
69	$\overline{\text{SRDY}}$	I	Input pin for ready signal indicating that serial data from control micro computer is complete.
70	SO	O	Output pin for sending serial data to control micro computer (8 bit data).
71	SOCK	I	Input pin for serial clock for SO.

Pin No.	Pin Name	I/O	Function
72	$\overline{\text{SORQ}}$	I	Input pin for serial output request signal.
73	$\overline{\text{SOAK}}$	O	Output pin for indicating that serial output is being executed.
74	$\overline{\text{VSS4}}$	—	GND
75	$\overline{\text{RES}}$	I	reset pin (with pull-up resistor).
76	$\overline{\text{INT}}$	I	Interrupt request input pin (with pull-up resistor).
77	$\overline{\text{VDD3}}$	—	+5V power pin
78	$\overline{\text{SELC}}$	I	Select pin (with pull-down resistor) used to determine whether system clock of LS83015 is produced from FS384I (L) or from self-run oscillating clock (H).
79	$\overline{\text{SACK1}}$	I	Select pin (with pull-down resistor) used to determine whether 1/3 frequency division output of FS3840 is used (L) or 1/4 frequency division output is used (H) as FS1280.
80	$\overline{\text{SACK2}}$	I	Select pin (with pull-down resistor) used to determine whether each FS output clock is produced from FS384I, LRCKI and BCK1 (L) or from self-run oscillating clock (H).

3-2. CIRCUIT BOARDS LOCATION

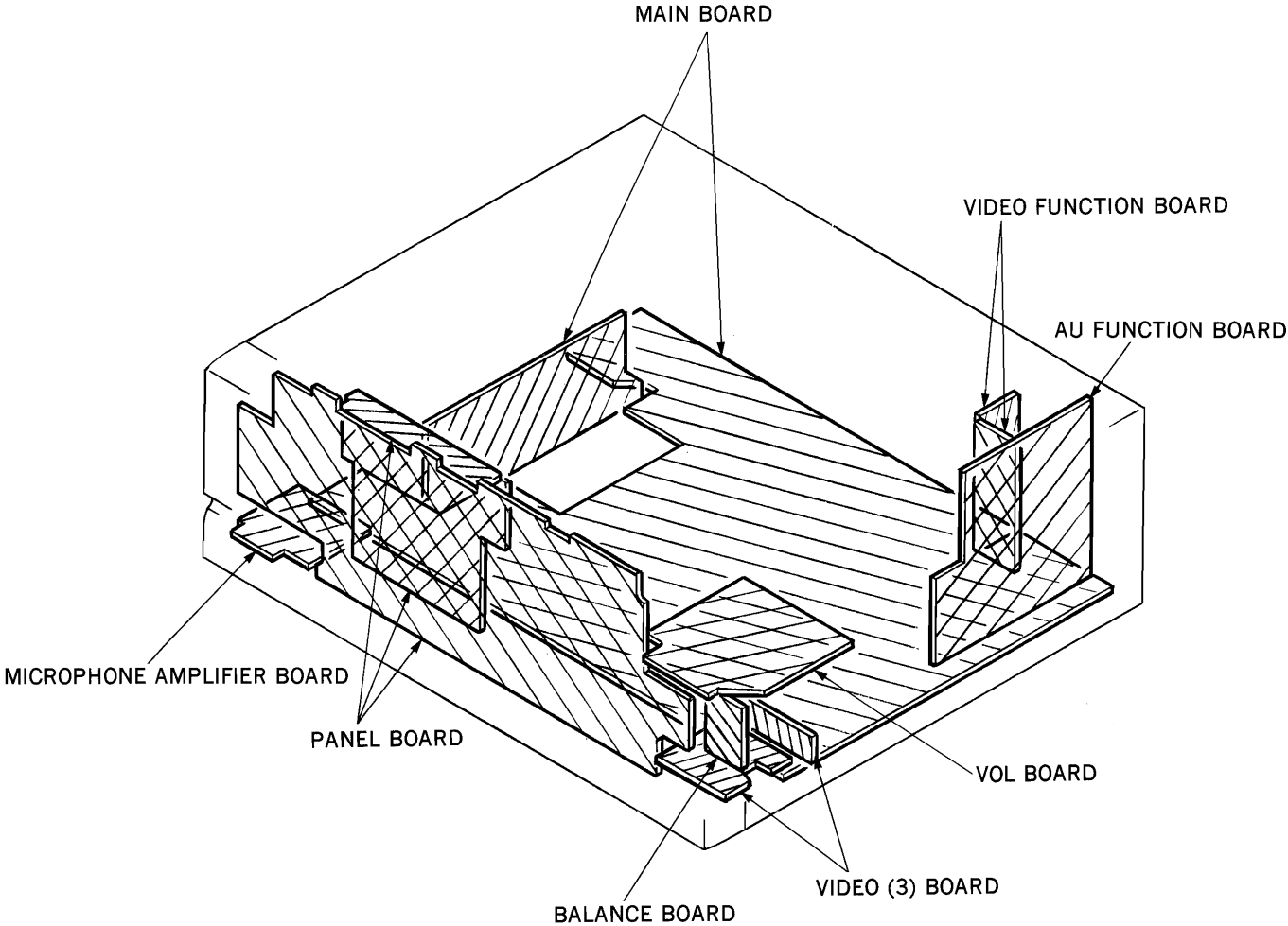

3-3. SEMICONDUCTOR LEAD LAYOUTS

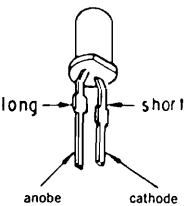
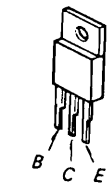
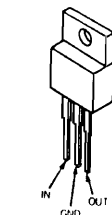
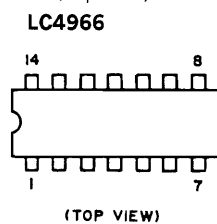
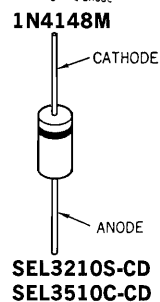
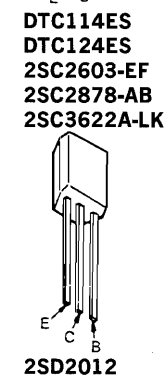
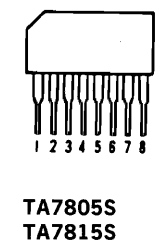
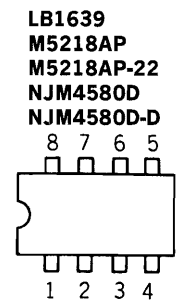
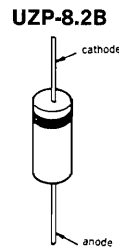
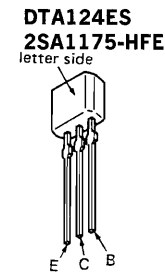
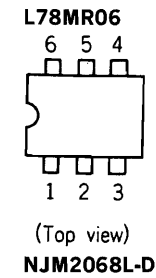
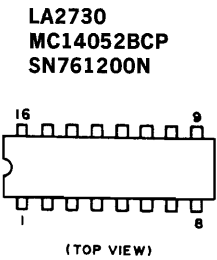
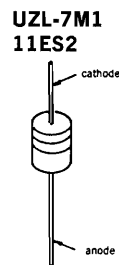
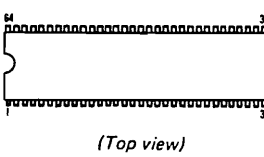
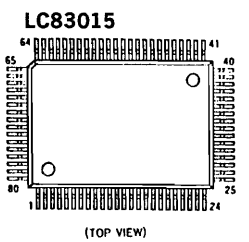
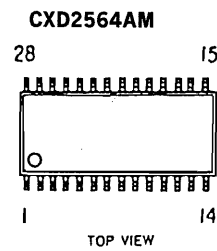
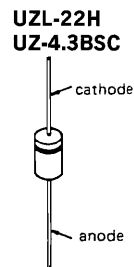
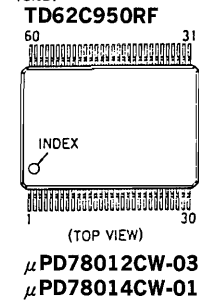
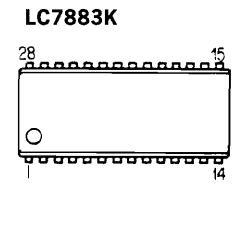
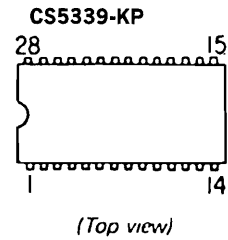
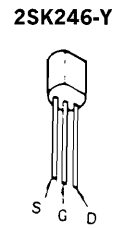
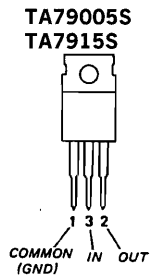
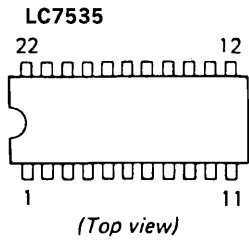
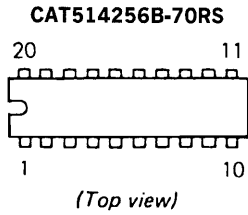

• IC Block Diagrams

IC201 CS5339-KP

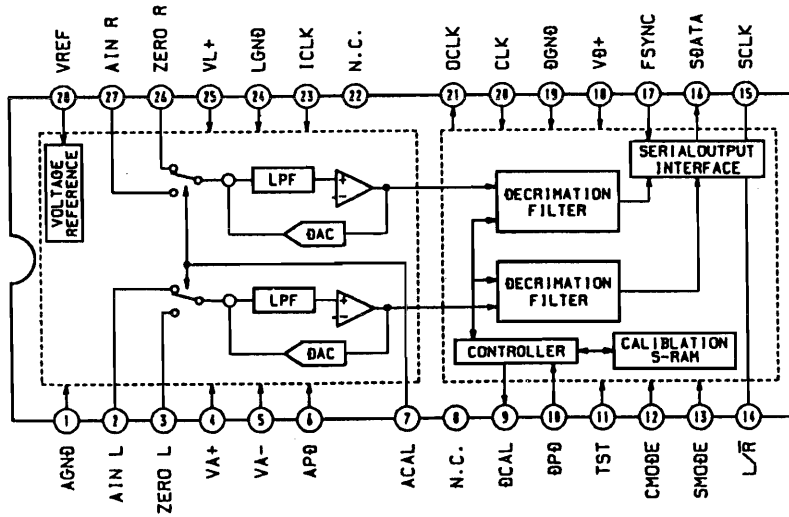

IC204 CXD2564AM

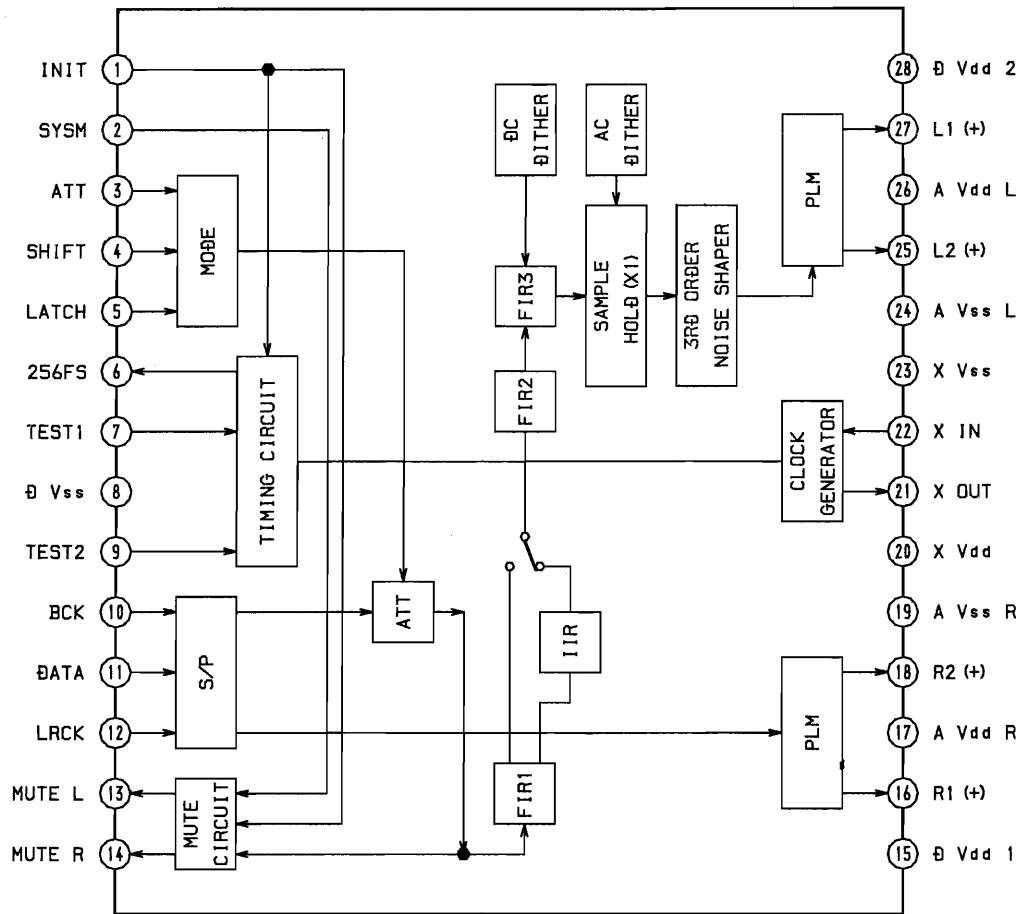

IC251 LB1639

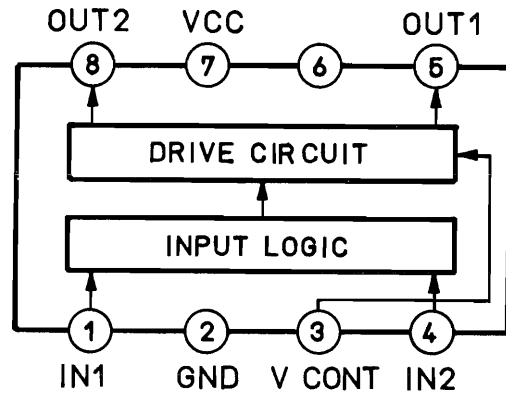

IC403 LC7535

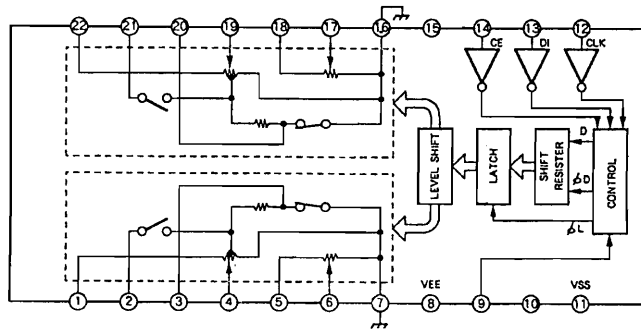

IC102, 103 MC14052 (AU FUNCTION board)

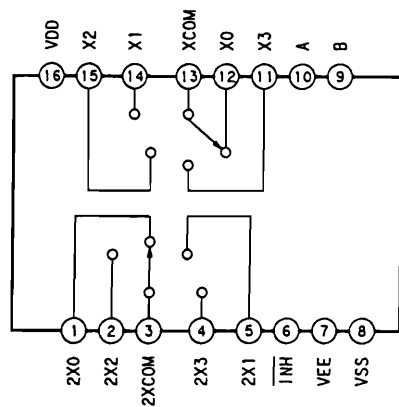

IC705 L78MR06

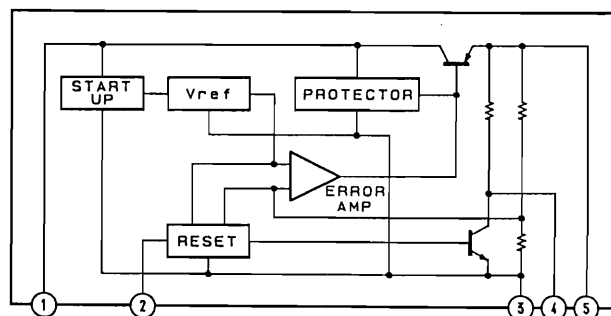

3-4. BLOCK DIAGRAM

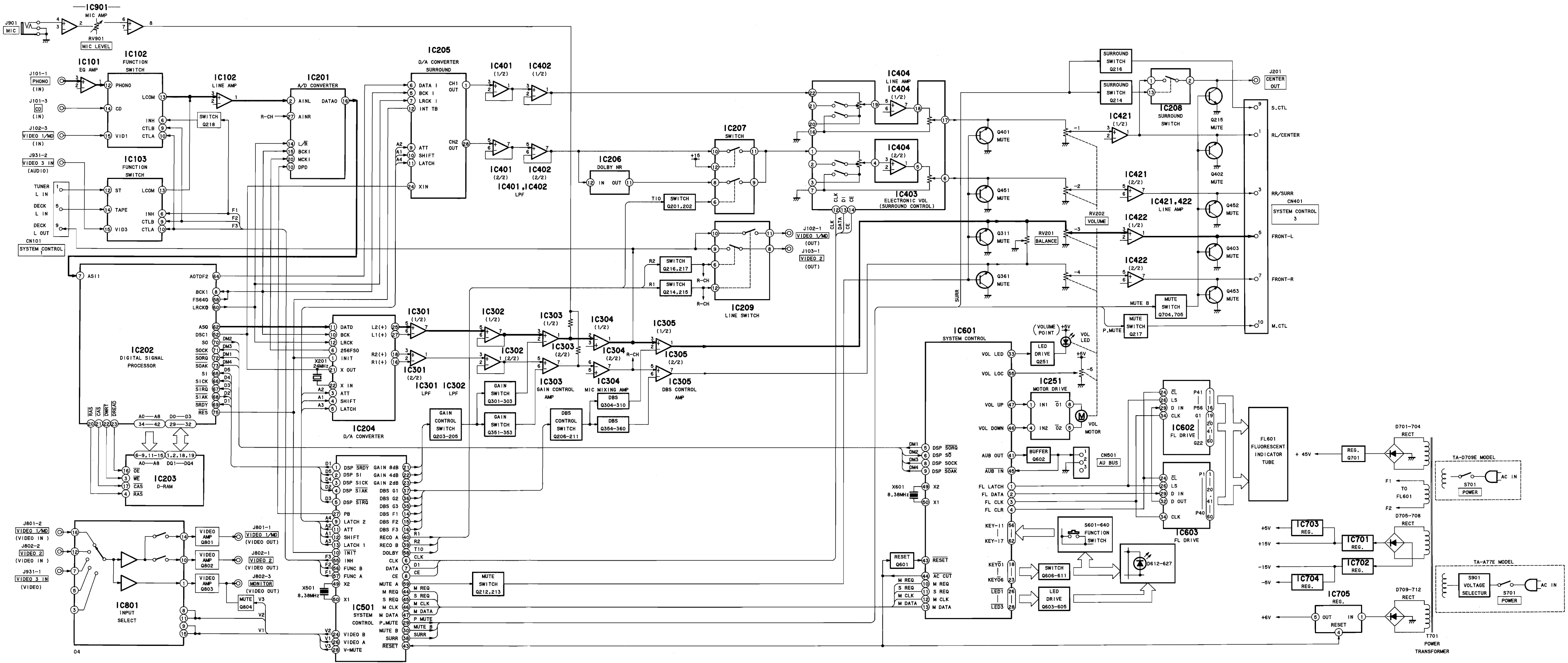

3-5. PRINTED WIRING BOARDS—MAIN SECTION (TYPE I)— • Refer to page 8 for Semiconductor Lead Layouts.

• Semiconductor Location

Ref. No.	Location	Ref. No.	Location
D251	I-25	IC801	B-3
D301	G-12	IC901	F-21
D302	F-12		
D303	G-12	Q201	I-7
D351	G-13	Q202	H-7
D352	F-13	Q203	D-12
D353	G-13	Q204	D-12
D701	J-17	Q205	D-12
D702	J-17	Q206	G-14
D703	J-17	Q207	G-14
D704	J-17	Q208	G-14
D705	H-17	Q209	H-13
D706	H-18	Q210	H-13
D707	G-17	Q211	H-13
D708	G-18	Q212	J-10
D709	E-17	Q213	J-10
D710	E-17	Q214	B-13
D711	E-17	Q215	B-13
D712	E-18	Q216	B-13
D713	J-18	Q217	B-14
D714	J-18	Q251	I-25
D715	J-14	Q301	D-14
D717	H-17	Q302	D-13
D718	H-17	Q303	D-13
D719	H-15	Q304	G-12
D720	H-16	Q305	F-12
D721	J-18	Q306	G-12
D722	B-14	Q307	G-11
		Q308	G-11
IC102	C-8	Q309	G-11
IC201	C-9	Q310	F-11
IC202	E-8	Q311	G-12
IC203	E-7	Q351	E-14
IC204	E-10	Q352	E-13
IC205	G-8	Q353	E-13
IC206	H-9	Q354	G-13
IC207	I-7	Q355	F-13
IC208	B-14	Q356	G-13
IC251	H-25	Q357	G-14
IC301	D-11	Q358	F-14
IC302	C-13	Q359	G-14
IC303	E-13	Q360	F-13
IC304	E-12	Q361	G-13
IC305	G-13	Q401	I-10
IC401	G-7	Q402	B-10
IC402	H-7	Q403	B-12
IC403	I-9	Q451	I-9
IC404	I-8	Q452	B-11
IC421	G-24	Q453	B-12
IC422	G-26	Q701	J-18
IC501	J-12	Q704	H-16
IC701	H-15	Q705	H-15
IC702	I-15	Q801	B-2
IC703	H-11	Q802	C-2
IC704	C-9	Q803	D-2
IC705	J-16	Q804	E-2

Note:
 • — : parts extracted from the component side.
 • — : Pattern on the side which is seen.
 • — : Jumper wire connected to the ground pattern on the component side.

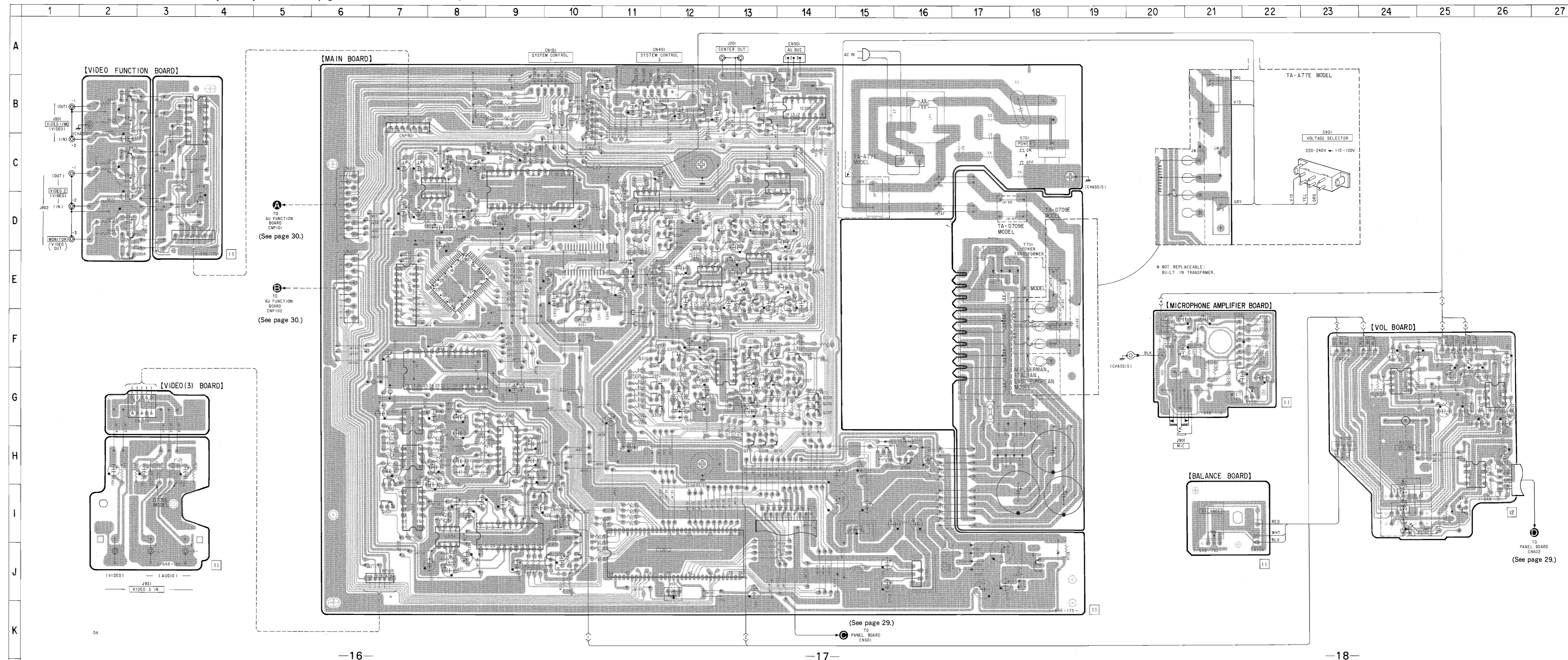

3-6. SCHEMATIC DIAGRAM — MAIN SECTION (TYPE 1) — Refer to page 9 for IC Block Diagrams.

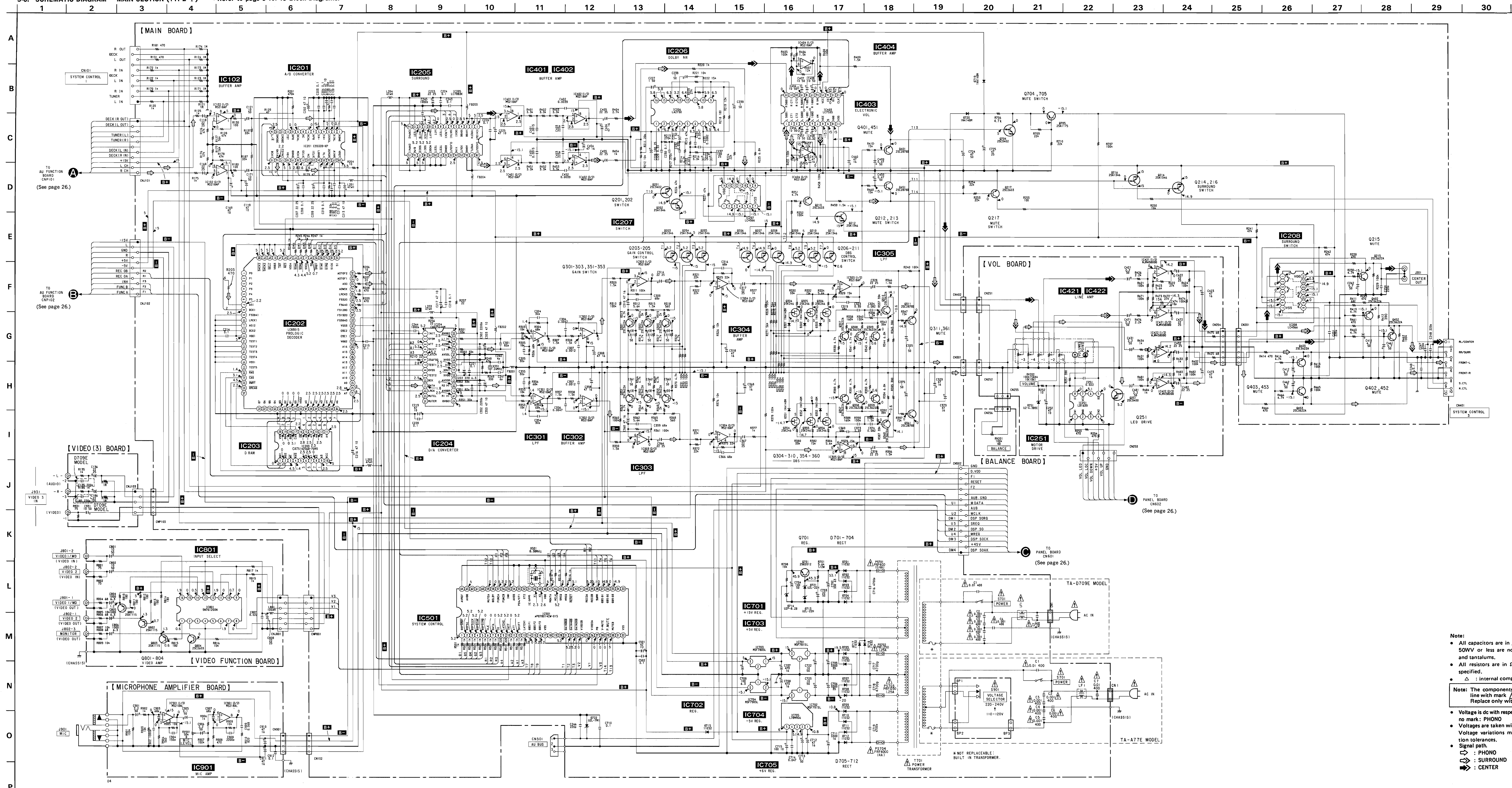

Note:

- All capacitors are in μF unless otherwise noted. pF: μF 50WV or less are not indicated except for electrolytics and tantalums.
- All resistors are in Ω and $\frac{1}{4}\text{W}$ or less unless otherwise specified.
- Δ : internal component.

Note: The components identified by mark Δ or dotted line with mark Δ are critical for safety. Replace only with part number specified.

- Voltage is dc with respect to ground under no-signal conditions.
- no mark: PHONO
- Voltagess are taken with a VOM (Input Impedance 10M Ω). Voltage variations may be noted due to normal production tolerances.
- Signal path
- PHONO
- SURROUND
- CENTER

3-7. SCHEMATIC DIAGRAM—PANEL SECTION (TYPE I) — Refer to page 9 for IC Block Diagrams.

1 2 3 4 5 6 7 8 9 10 11 12 13 14 15 16 17 18 19 20 21 22 23 24 25 26 27 28 29

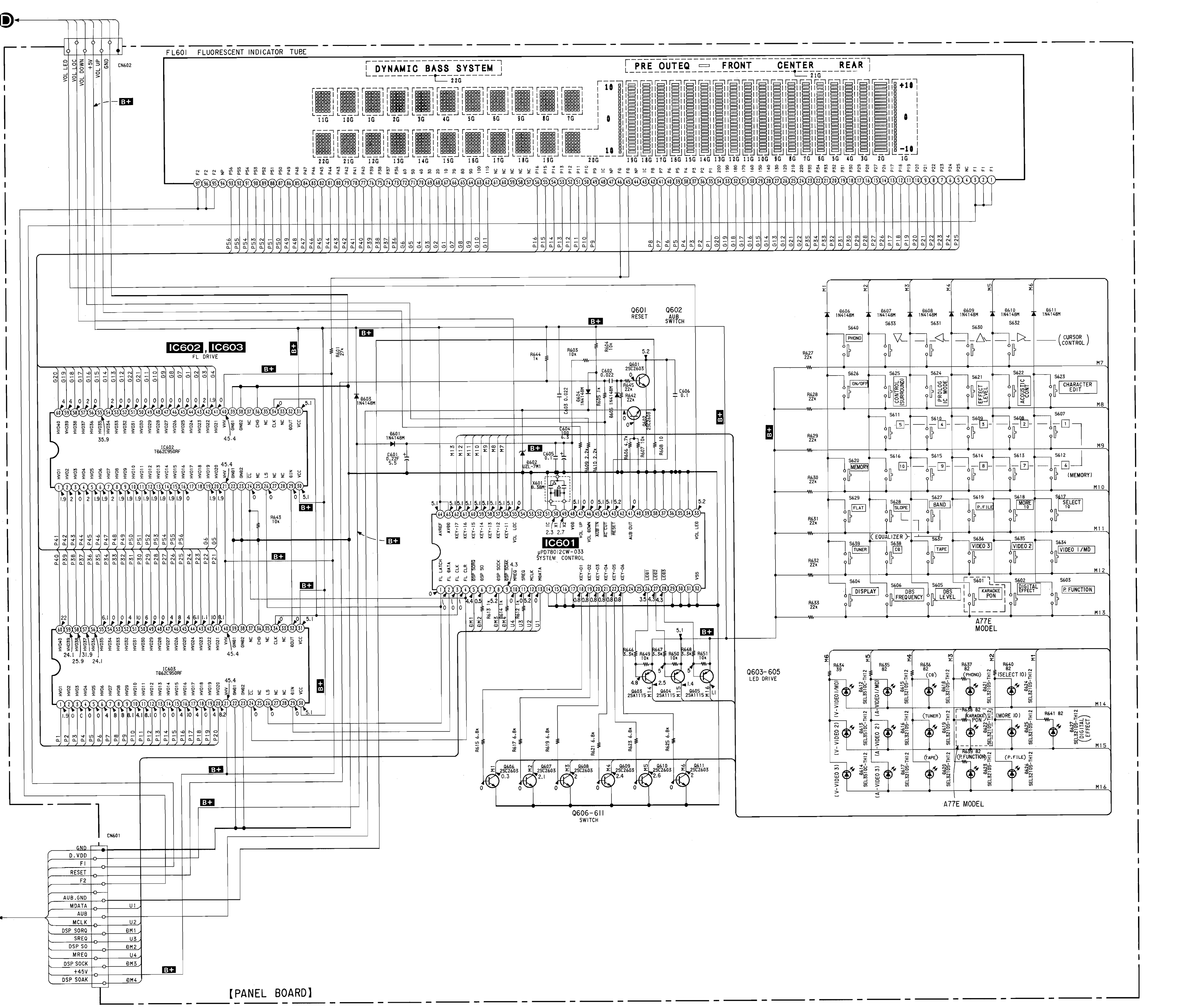
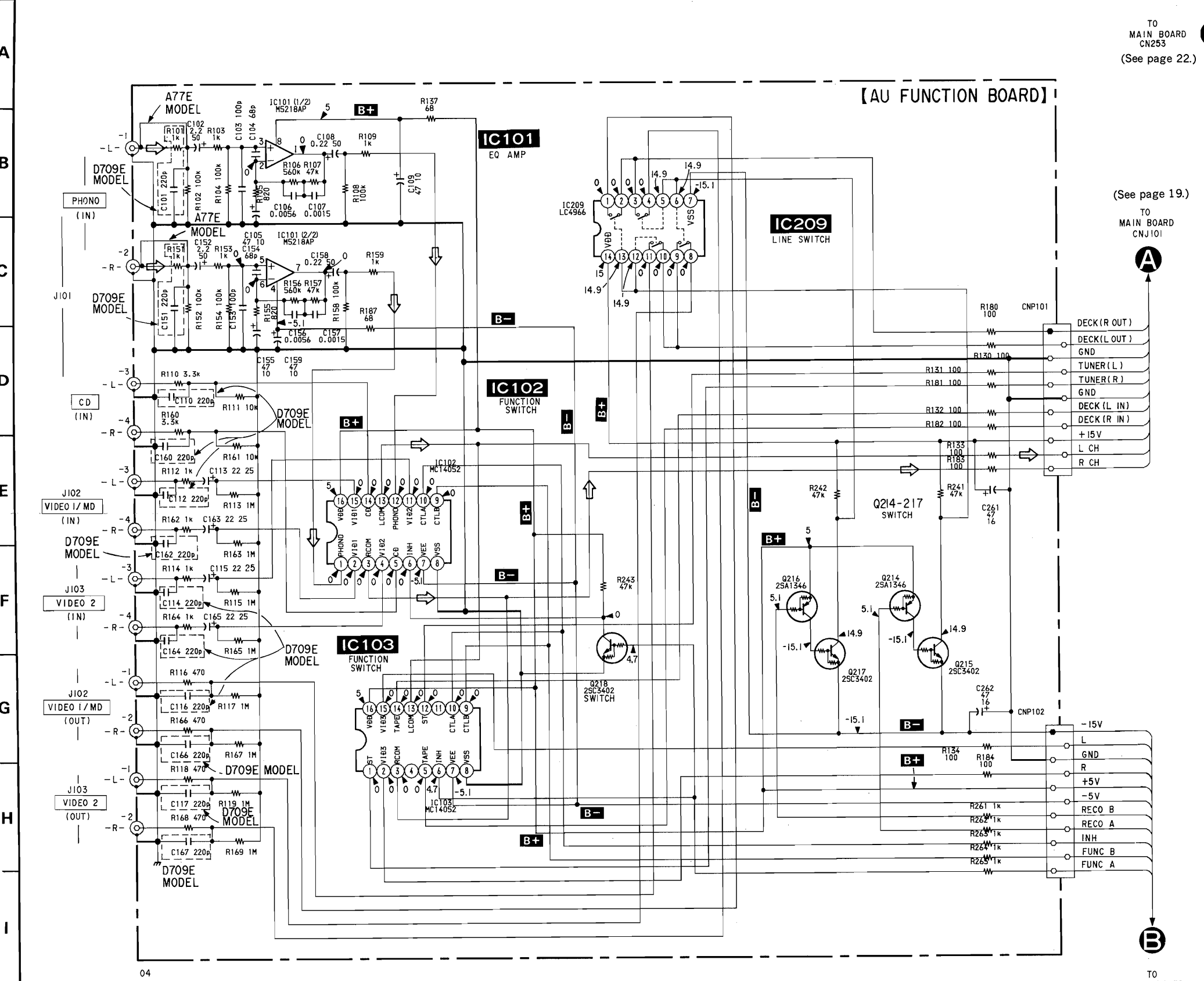

- Note:
- All capacitors are in μF unless otherwise noted. pF: μF 50WV or less are not indicated except for electrolytics and tantalums.
 - All resistors are in Ω and $\frac{1}{4}\text{W}$ or less unless otherwise specified.
 - Δ : internal component.
 - Voltage is dc with respect to ground under no-signal conditions. no mark: PHONO
 - Voltages are taken with a VOM (input impedance 10M Ω). Voltage variations may be noted due to normal production tolerances.
 - Signal path.
 - \square : PHONO

3-8. PRINTED WIRING BOARDS—PANEL SECTION (TYPE I) — • Refer to page 8 for Semiconductor Lead Layouts.

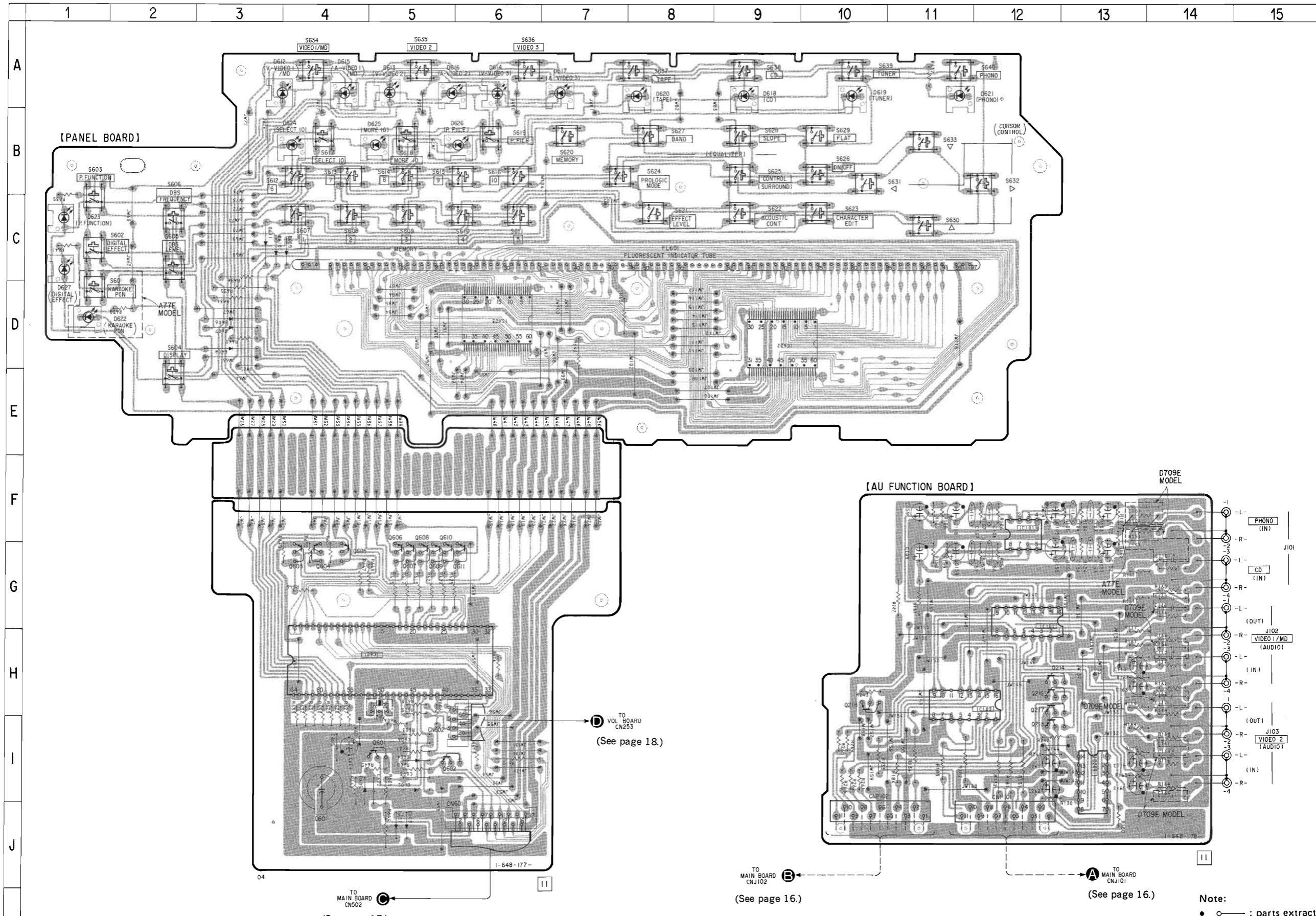

• Semiconductor Location

Ref. No.	Location
D601	J-5
D602	I-5
D603	J-5
D604	I-5
D605	I-4
D606	D-3
D607	D-3
D608	D-3
D609	C-4
D610	C-3
D611	C-3
D612	A-3
D613	A-5
D614	A-6
D615	A-4
D616	A-5
D617	A-7
D618	A-9
D619	A-10
D620	A-8
D621	A-11
(D622)	D-1
D623	C-1
D624	B-4
D625	B-5
D626	B-6
D627	C-1
IC101	F-12
IC102	G-12
IC103	H-11
IC209	I-13
IC601	H-5
IC602	D-9
IC603	D-6
Q214	H-12
Q215	I-12
Q216	H-12
Q217	H-12
Q218	H-10
Q601	I-5
Q602	I-5
Q603	G-4
Q604	G-4
Q605	G-4
Q606	G-5
Q607	G-5
Q608	G-5
Q609	G-5
Q610	G-5
Q611	G-6

(): TA-A77E only

Note:
 • ○ : parts extracted from the component side.
 • ■ : Pattern on the side which is seen.

● Semiconductor Location

Ref. No.	Location
D601	J-5
D602	I-5
D603	J-5
D604	I-5
D605	I-4
D606	D-3
D607	D-3
D608	D-3
D609	C-4
D610	C-3
D611	C-3
D612	A-3
D613	A-5
D614	A-6
D615	A-4
D616	A-5
D617	A-7
D618	A-9
D619	A-10
D620	A-8
D621	A-11
(D622)	D-1
D623	C-1
D624	B-4
D625	B-5
D626	B-6
D627	C-1
IC101	F-12
IC102	G-12
IC103	H-11
IC209	I-13
IC601	H-5
IC602	D-9
IC603	D-6
Q214	H-12
Q215	I-12
Q216	H-12
Q217	H-12
Q218	H-10
Q601	I-5
Q602	I-5
Q603	G-4
Q604	G-4
Q605	G-4
Q606	G-5
Q607	G-5
Q608	G-5
Q609	G-5
Q610	G-5
Q611	G-6

(): TA-A77E only

Note:
 ● — : parts extracted from the component side.
 ● — : Pattern on the side which is seen.

3-9. PRINTED WIRING BOARDS—PANEL SECTION (TYPE II)— ● Refer to page 8 for Semiconductor Lead Layouts.

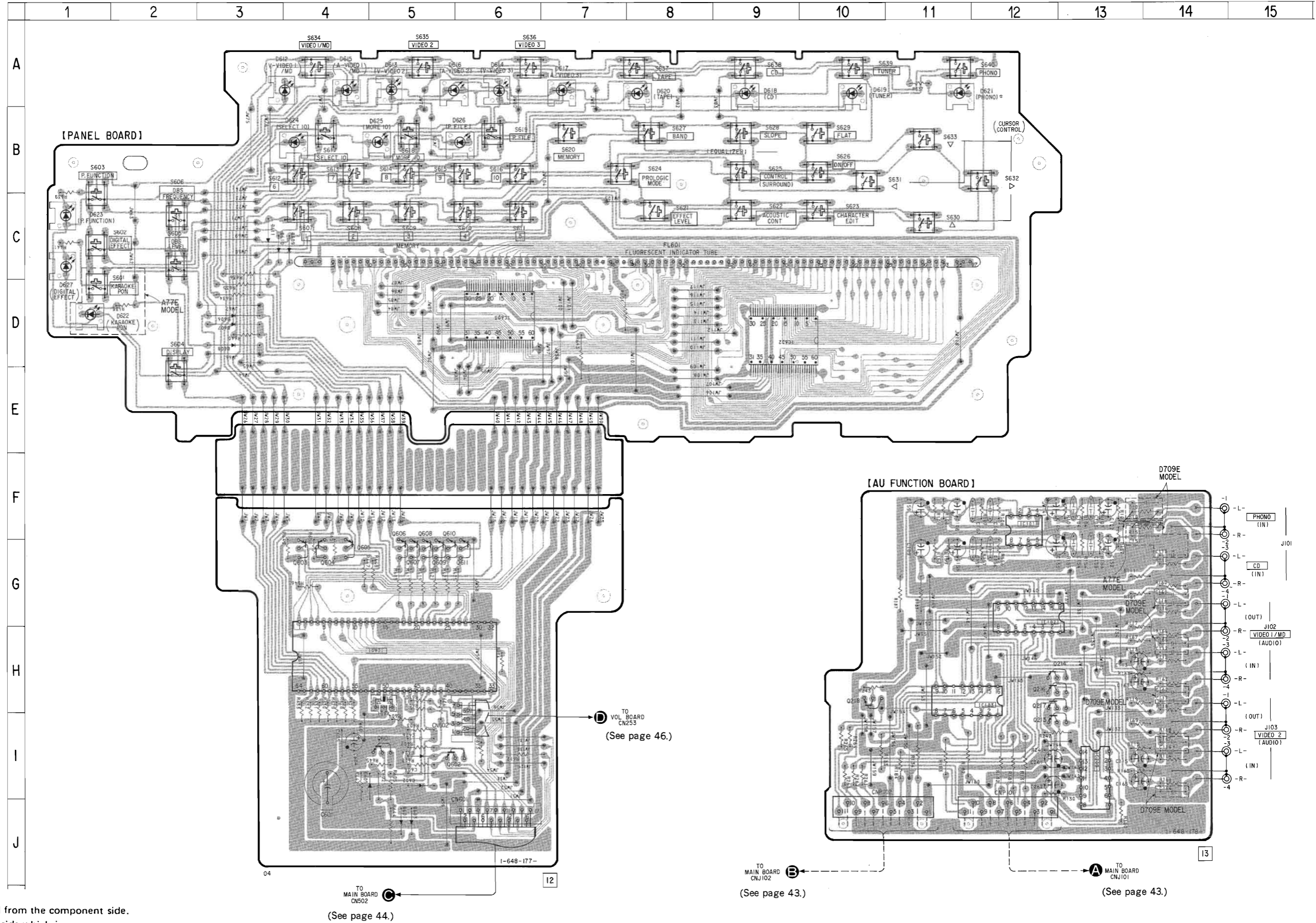

3-10. SCHEMATIC DIAGRAM—PANEL SECTION (TYPE II)— Refer to page 9 for IC Block Diagrams.

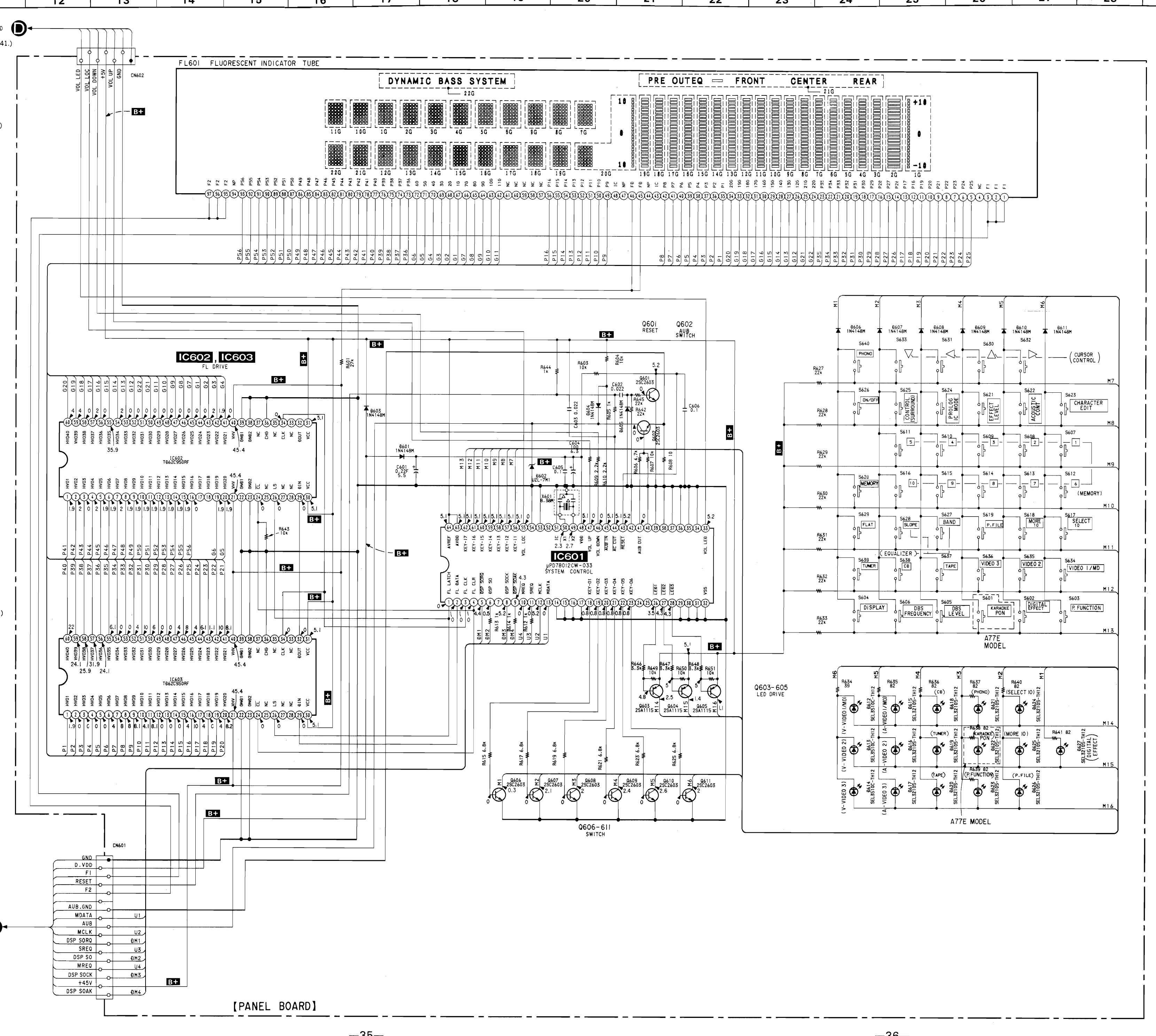
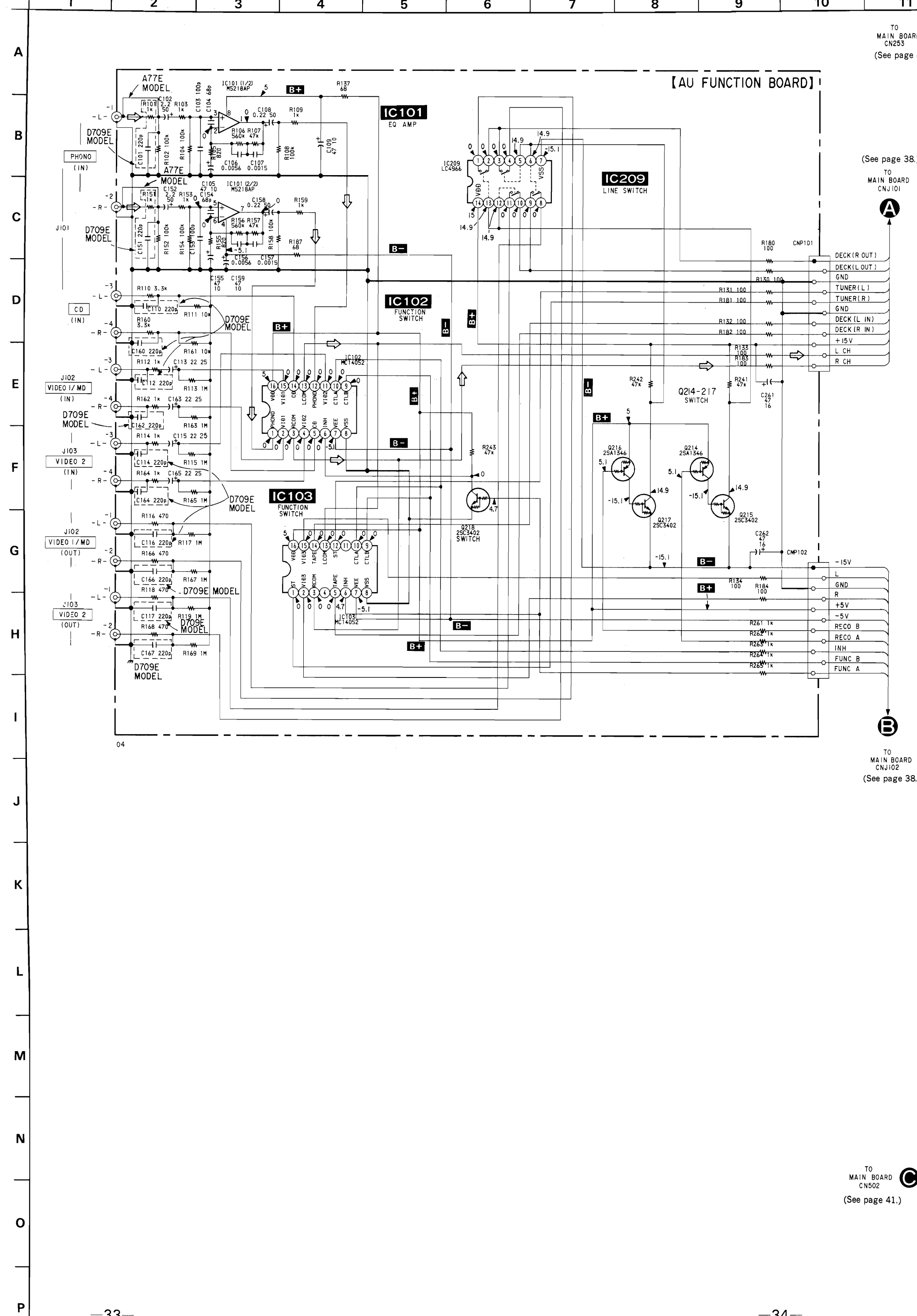

- Note:
- All capacitors are in μF unless otherwise noted, pF : μF 50WV or less are not indicated except for electrolytics and tantalums.
 - All resistors are in Ω and $\frac{1}{4}\text{W}$ or less unless otherwise specified.
 - Δ : internal component.
 - Voltage is dc with respect to ground under no-signal conditions. no mark: PHONO
 - Voltages are taken with a VOM (input impedance 10M Ω). Voltage variations may be noted due to normal production tolerances.
 - Signal path.
 - \square : PHONO

3-11. SCHEMATIC DIAGRAM—MAIN SECTION (TYPE II) — Refer to page 9 for IC Block Diagrams.

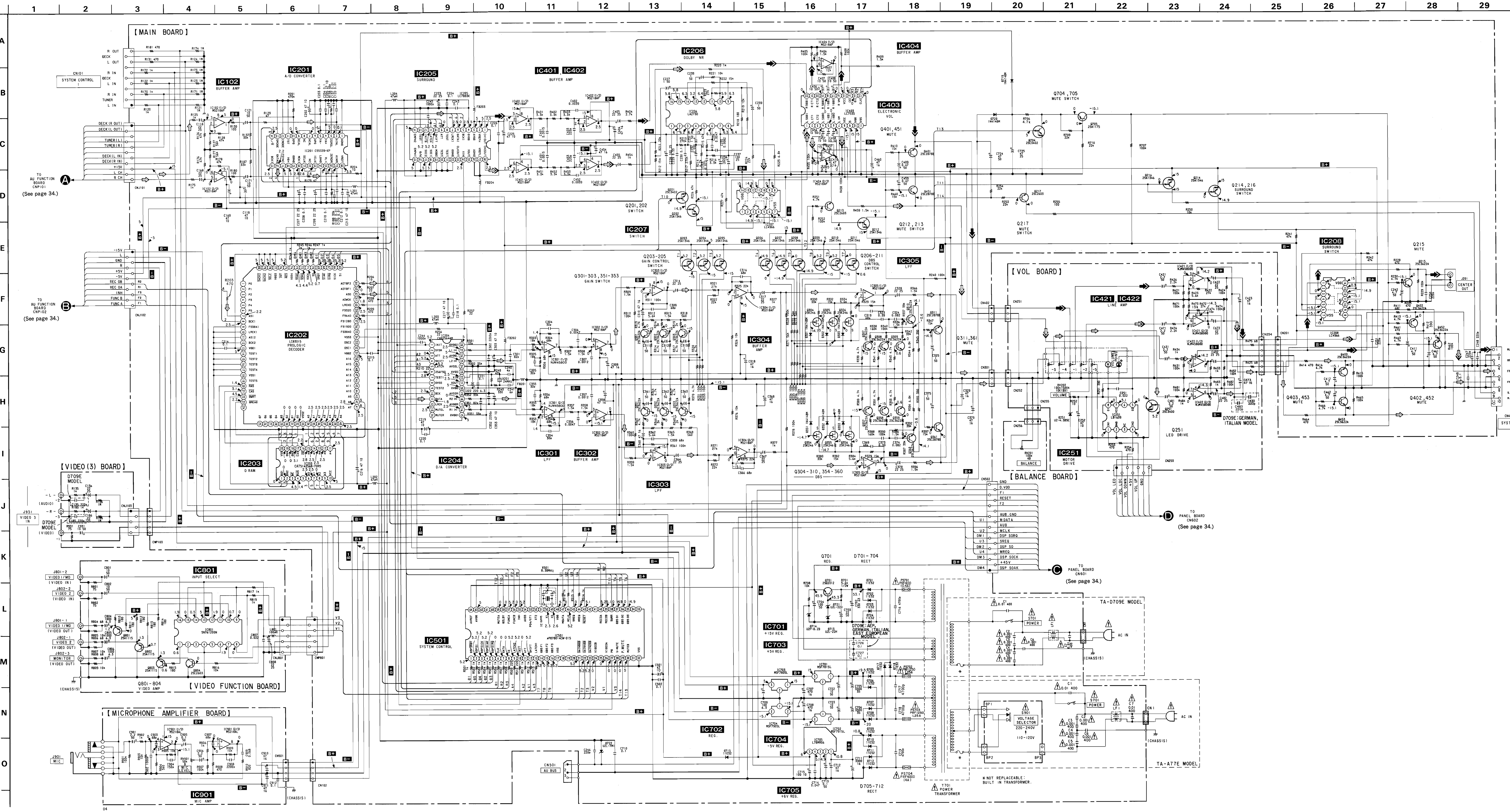

Note:
 • All capacitors are in μF unless otherwise noted, pF: μpF 50WV or less are not indicated except for electrolytics and tantalums.
 • All resistors are in Ω and $\frac{1}{4}\text{W}$ or less unless otherwise specified.
 • Δ : internal component.
 Note: The components identified by mark Δ or dotted line with mark Δ are critical for safety. Replace only with part number specified.
 • Voltage is dc with respect to ground under no-signal conditions. no mark: PHONO
 • Voltages are taken with a VOM (Input Impedance 10M Ω). Voltage variations may be noted due to normal production tolerances.
 • Signal path
 ○: PHONO
 ○: SURROUND
 ○: CENTER

3-12. PRINTED WIRING BOARDS—MAIN SECTION (TYPE II)— Refer to page 8 for Semiconductor Lead Layouts.

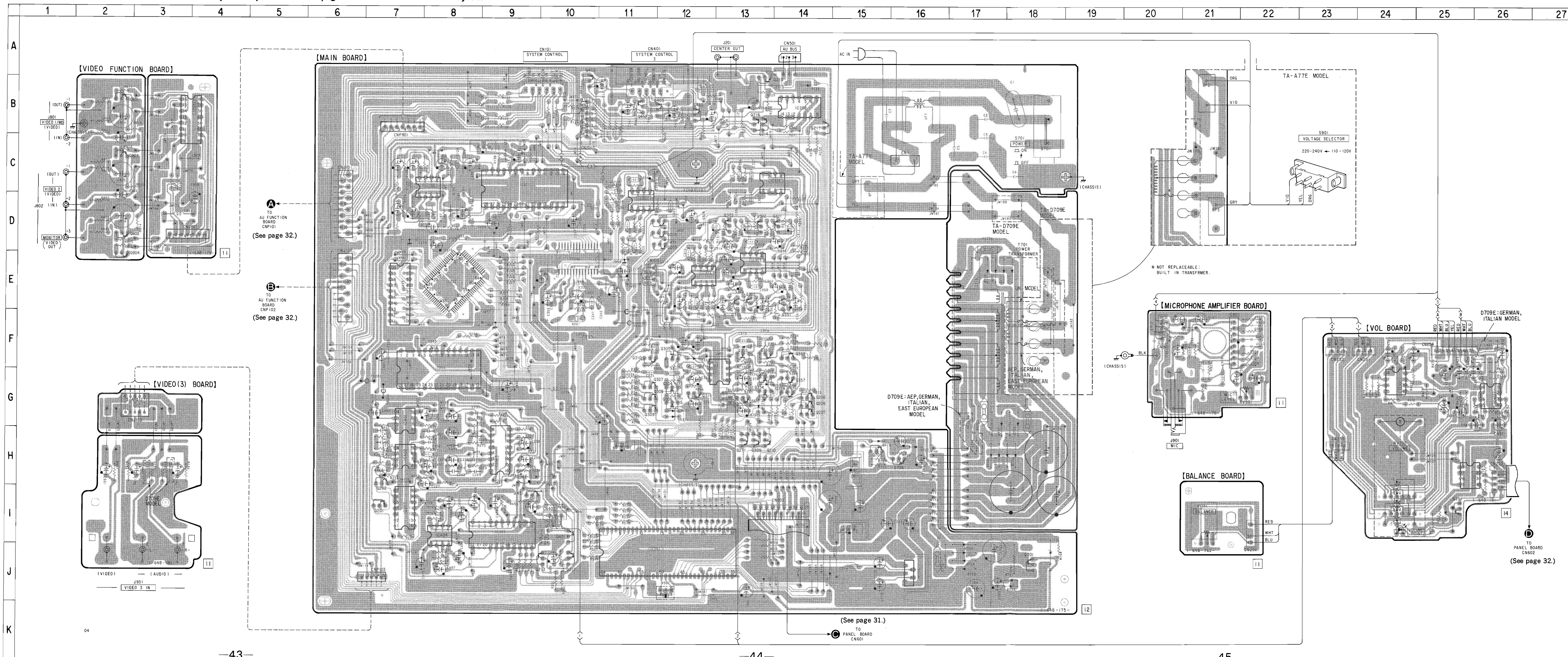

● Semiconductor Location

Ref. No.	Location	Ref. No.	Location
D251	I-25	IC801	B-3
D301	G-12	IC901	F-21
D302	F-12		
D303	G-12	Q201	I-7
D351	G-13	Q202	H-7
D352	F-13	Q203	D-12
D353	G-13	Q204	D-12
D701	J-17	Q205	D-12
D702	J-17	Q206	G-14
D703	J-17	Q207	G-14
D704	J-17	Q208	G-14
D705	H-17	Q209	H-13
D706	H-18	Q210	H-13
D707	G-17	Q211	H-13
D708	G-18	Q212	J-10
D709	E-17	Q213	J-10
D710	E-17	Q214	B-13
D711	E-17	Q215	B-13
D712	E-18	Q216	B-13
D713	J-18	Q217	B-14
D714	J-18	Q251	I-25
D715	J-14	Q301	D-14
D717	H-17	Q302	D-13
D718	H-17	Q303	D-13
D719	H-15	Q304	G-12
D720	H-16	Q305	F-12
D721	J-18	Q306	G-12
D722	B-14	Q307	G-11
		Q308	G-11
IC102	C-8	Q309	G-11
IC201	C-9	Q310	F-11
IC202	E-8	Q311	G-12
IC203	E-7	Q351	E-14
IC204	E-10	Q352	E-13
IC205	G-8	Q353	E-13
IC206	H-9	Q354	G-13
IC207	I-7	Q355	F-13
IC208	B-14	Q356	G-13
IC251	H-25	Q357	G-14
IC301	D-11	Q358	F-14
IC302	C-13	Q359	G-14
IC303	E-13	Q360	F-13
IC304	E-12	Q361	G-13
IC305	G-13	Q401	I-10
IC401	G-7	Q402	B-10
IC402	H-7	Q403	B-12
IC403	I-9	Q451	I-9
IC404	I-8	Q452	B-11
IC421	G-24	Q453	B-12
IC422	G-26	Q701	J-18
IC501	J-12	Q704	H-16
IC701	H-15	Q705	H-15
IC702	I-15	Q801	B-2
IC703	H-11	Q802	C-2
IC704	C-9	Q803	D-2
IC705	J-16	Q804	E-2

Note:

- ○ — : parts extracted from the component side.
- ■ : Pattern on the side which is seen.
- ○ — : Jumper wire connected to the ground pattern on the component side.

3-13. PRINTED WIRING BOARDS—MAIN SECTION (TYPE III)— Refer to page 8 for Semiconductor Lead Layouts.

• Semiconductor Location

Ref. No.	Location	Ref. No.	Location
D251	I-25	IC801	B-3
D301	G-12	IC901	F-21
D302	F-12		
D303	G-12	Q201	I-7
D351	G-13	Q202	H-7
D352	F-13	Q203	D-12
D353	G-13	Q204	D-12
D701	J-17	Q205	D-12
D702	J-17	Q206	G-14
D703	J-17	Q207	G-14
D704	J-17	Q208	G-14
D705	H-17	Q209	H-13
D706	H-18	Q210	H-13
D707	G-17	Q211	H-13
D708	G-18	Q212	J-10
D709	E-17	Q213	J-10
D710	E-17	Q214	B-13
D711	E-17	Q215	B-13
D712	E-18	Q216	B-13
D713	J-18	Q217	B-14
D714	J-18	Q251	I-25
D715	J-14	Q301	D-14
D717	H-17	Q302	D-13
D718	H-17	Q303	D-13
D719	H-15	Q304	G-12
D720	H-16	Q305	F-12
D721	J-18	Q306	G-12
D722	B-14	Q307	G-11
		Q308	G-11
IC102	C-8	Q309	G-11
IC201	C-9	Q310	F-11
IC202	E-8	Q311	G-12
IC203	E-7	Q351	E-14
IC204	E-10	Q352	E-13
IC205	G-8	Q353	E-13
IC206	H-9	Q354	G-13
IC207	I-7	Q355	F-13
IC208	B-14	Q356	G-13
IC251	H-25	Q357	G-14
IC301	D-11	Q358	F-14
IC302	C-13	Q359	G-14
IC303	E-13	Q360	F-13
IC304	E-12	Q361	G-13
IC305	G-13	Q401	I-10
IC401	G-7	Q402	B-10
IC402	H-7	Q403	B-12
IC403	I-9	Q451	I-9
IC404	I-8	Q452	B-11
IC421	G-24	Q453	B-12
IC422	G-26	Q701	J-18
IC501	J-12	Q704	H-16
IC701	H-15	Q705	H-15
IC702	I-15	Q801	B-2
IC703	H-11	Q802	C-2
IC704	C-9	Q803	D-2
IC705	J-16	Q804	E-2

Note:
 • — : parts extracted from the component side.
 • — : Pattern on the side which is seen.
 • — : Jumper wire connected to the ground pattern on the component side.

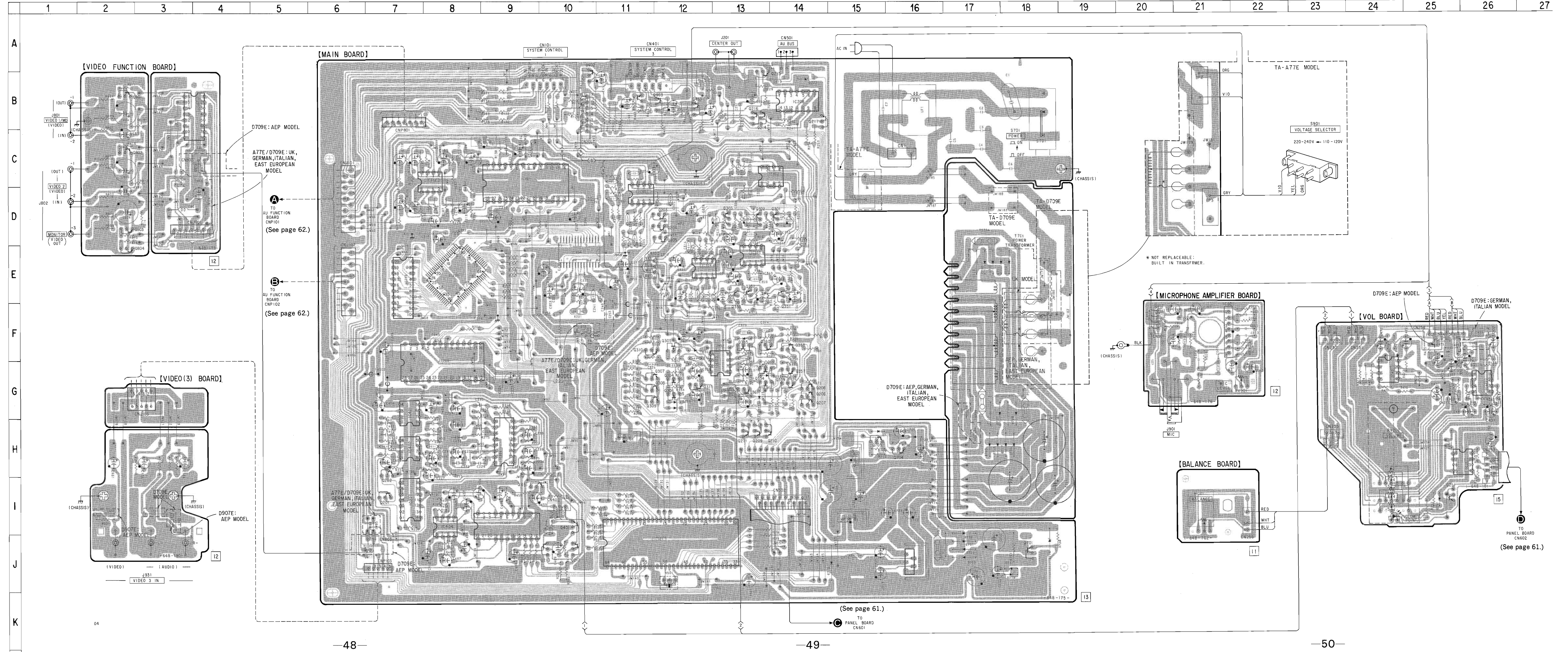

3-14. SCHEMATIC DIAGRAM—MAIN SECTION (TYPE III) — Refer to page 9 for IC Block Diagrams.

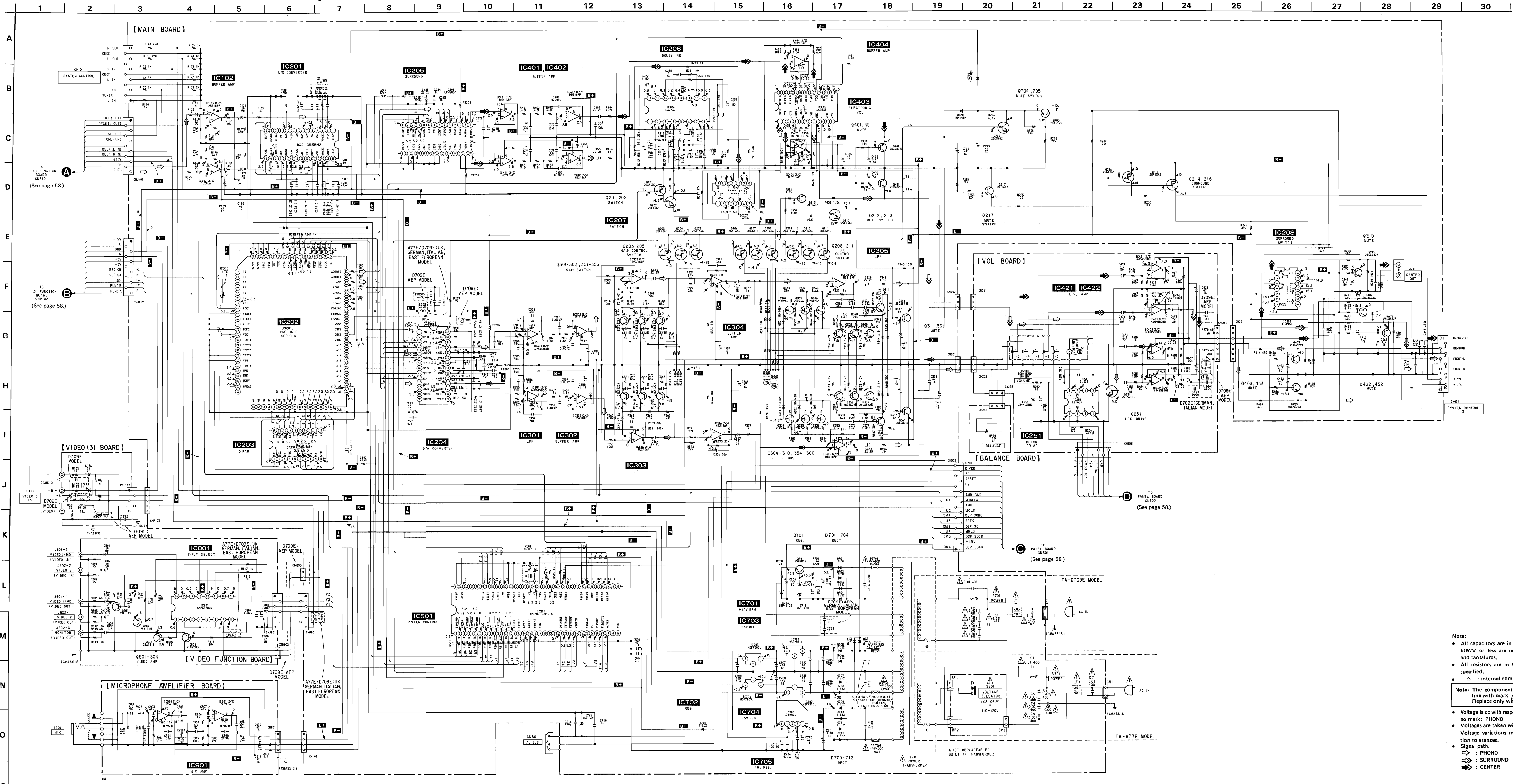

- Note:**
- All capacitors are in μF unless otherwise noted; pF; μF 50WV or less are not indicated except for electrolytics and tantalums.
 - All resistors are in Ω and $\frac{1}{2}W$ or less unless otherwise specified.
 - Δ : internal component.
- Note:** The components identified by mark Δ or dotted line with mark Δ are critical for safety. Replace only with part number specified.
- Voltage is dc with respect to ground under no-signal conditions. no mark: PHONO
 - Voltagess are taken with a VOM (input impedance 10M Ω). Voltage variations may be noted due to normal production tolerances.
 - Signal path:
 - \rightarrow : PHONO
 - \rightarrow : SURROUND
 - \rightarrow : CENTER

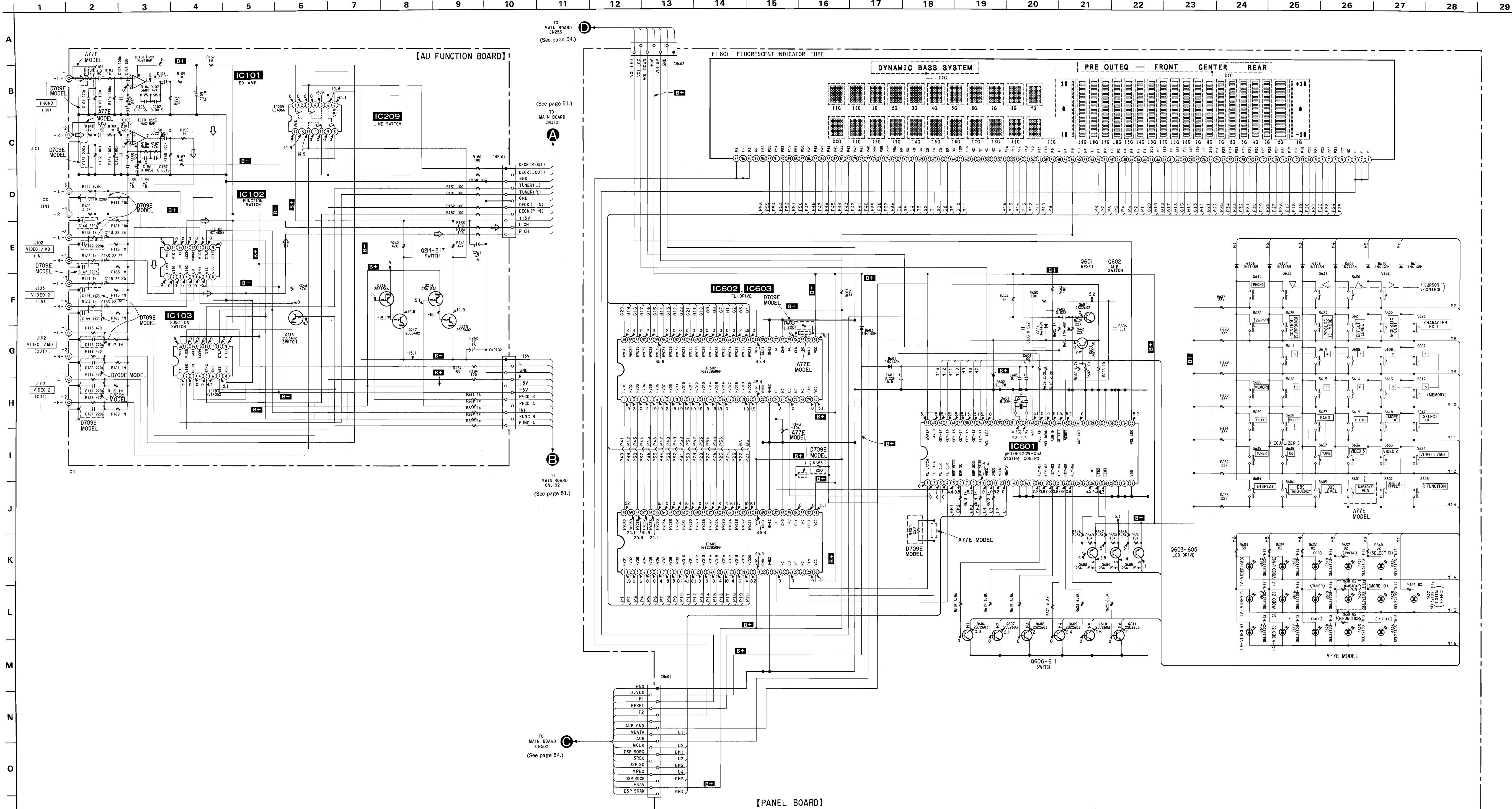

- Notes:**
- All capacitors are in μF unless otherwise noted. pF: μpF 50WV or less are not indicated except for electrolytic and tantalum.
 - All resistors are in Ω and $\frac{1}{4}\text{W}$ or less unless otherwise specified.
 - Δ : internal component.
 - Voltage is dc with respect to ground under no-signal conditions. no mark: PHONO
 - Voltages are taken with a VOM (Input Impedance $10\text{M}\Omega$). Voltage variations may be noted due to normal production tolerances.
 - Signal path.
 - \rightarrow : PHONO

3-16. PRINTED WIRING BOARDS—PANEL SECTION (TYPE III)— Refer to page 8 for Semiconductor Lead Layouts.

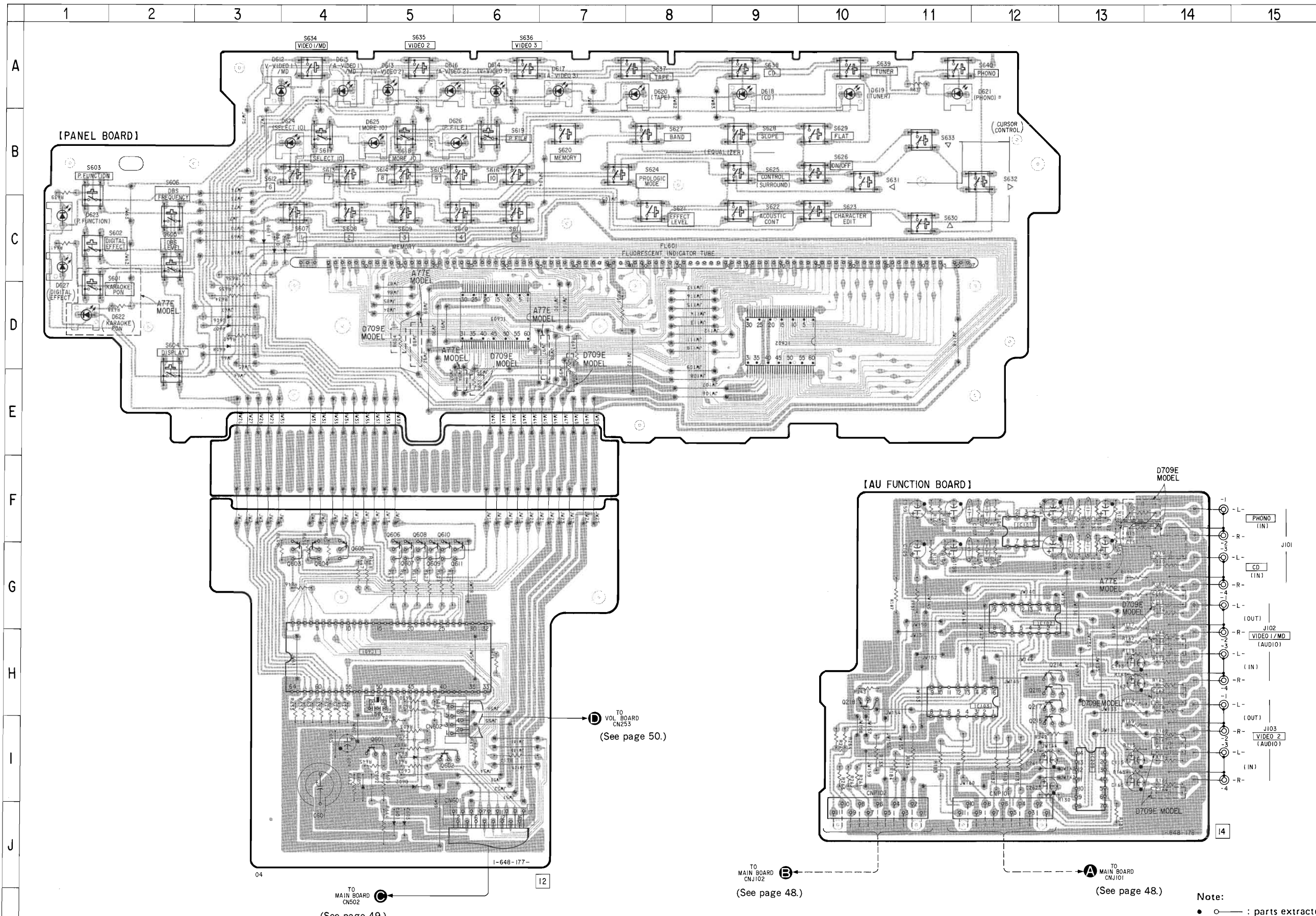

• Semiconductor Location

Ref. No.	Location
D601	J-5
D602	I-5
D603	J-5
D604	I-5
D605	I-4
D606	D-3
D607	D-3
D608	D-3
D609	C-4
D610	C-3
D611	C-3
D612	A-3
D613	A-5
D614	A-6
D615	A-4
D616	A-5
D617	A-7
D618	A-9
D619	A-10
D620	A-8
D621	A-11
(D622)	D-1
D623	C-1
D624	B-4
D625	B-5
D626	B-6
D627	C-1
IC101	F-12
IC102	G-12
IC103	H-11
IC209	I-13
IC601	H-5
IC602	D-9
IC603	D-6
Q214	H-12
Q215	I-12
Q216	H-12
Q217	H-12
Q218	H-10
Q601	I-5
Q602	I-5
Q603	G-4
Q604	G-4
Q605	G-4
Q606	G-5
Q607	G-5
Q608	G-5
Q609	G-5
Q610	G-5
Q611	G-6

(): TA-A77E only

Note:
 • ○ : parts extracted from the component side.
 • ■ : Pattern on the side which is seen.

● Semiconductor Location

Ref. No.	Location
D601	J-5
D602	I-5
D603	J-5
D604	I-5
D605	I-4
D606	D-3
D607	D-3
D608	D-3
D609	C-4
D610	C-3
D611	C-3
D612	A-3
D613	A-5
D614	A-6
D615	A-4
D616	A-5
D617	A-7
D618	A-9
D619	A-10
D620	A-8
D621	A-11
(D622)	D-1
D623	C-1
D624	B-4
D625	B-5
D626	B-6
D627	C-1
IC101	F-12
IC102	G-12
IC103	H-11
IC209	I-13
IC601	H-5
IC602	D-9
IC603	D-6
Q214	H-12
Q215	I-12
Q216	H-12
Q217	H-12
Q218	H-10
Q601	I-5
Q602	I-5
Q603	G-4
Q604	G-4
Q605	G-4
Q606	G-5
Q607	G-5
Q608	G-5
Q609	G-5
Q610	G-5
Q611	G-6

(): TA-A77E only

3-17. PRINTED WIRING BOARDS—PANEL SECTION (TYPE IV)— ● Refer to page 8 for Semiconductor Lead Layouts.

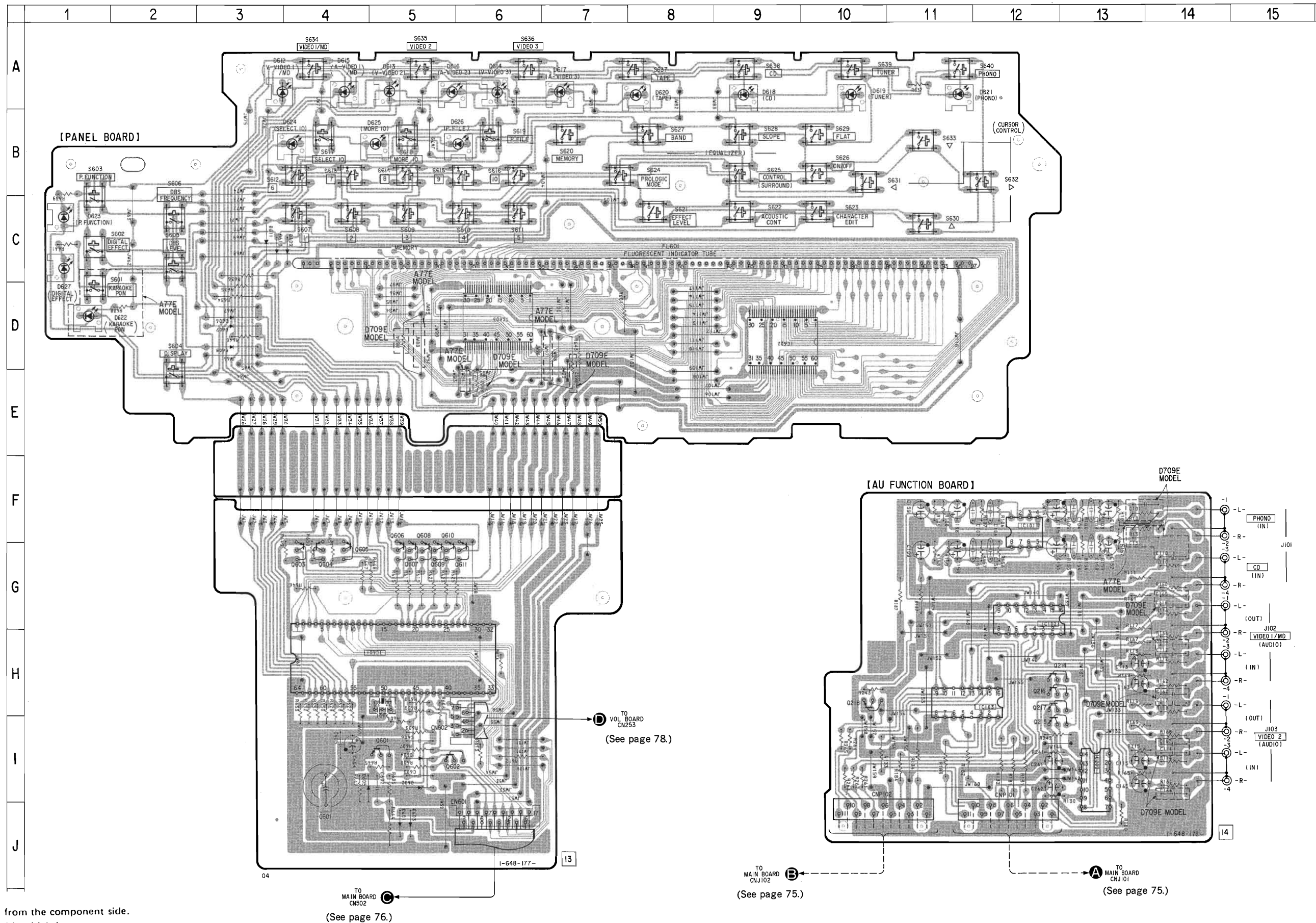

Note:
 ● ○ : parts extracted from the component side.
 ● ■ : Pattern on the side which is seen.

3-18. SCHEMATIC DIAGRAM—PANEL SECTION (TYPE IV) — Refer to page 9 for IC Block Diagrams.

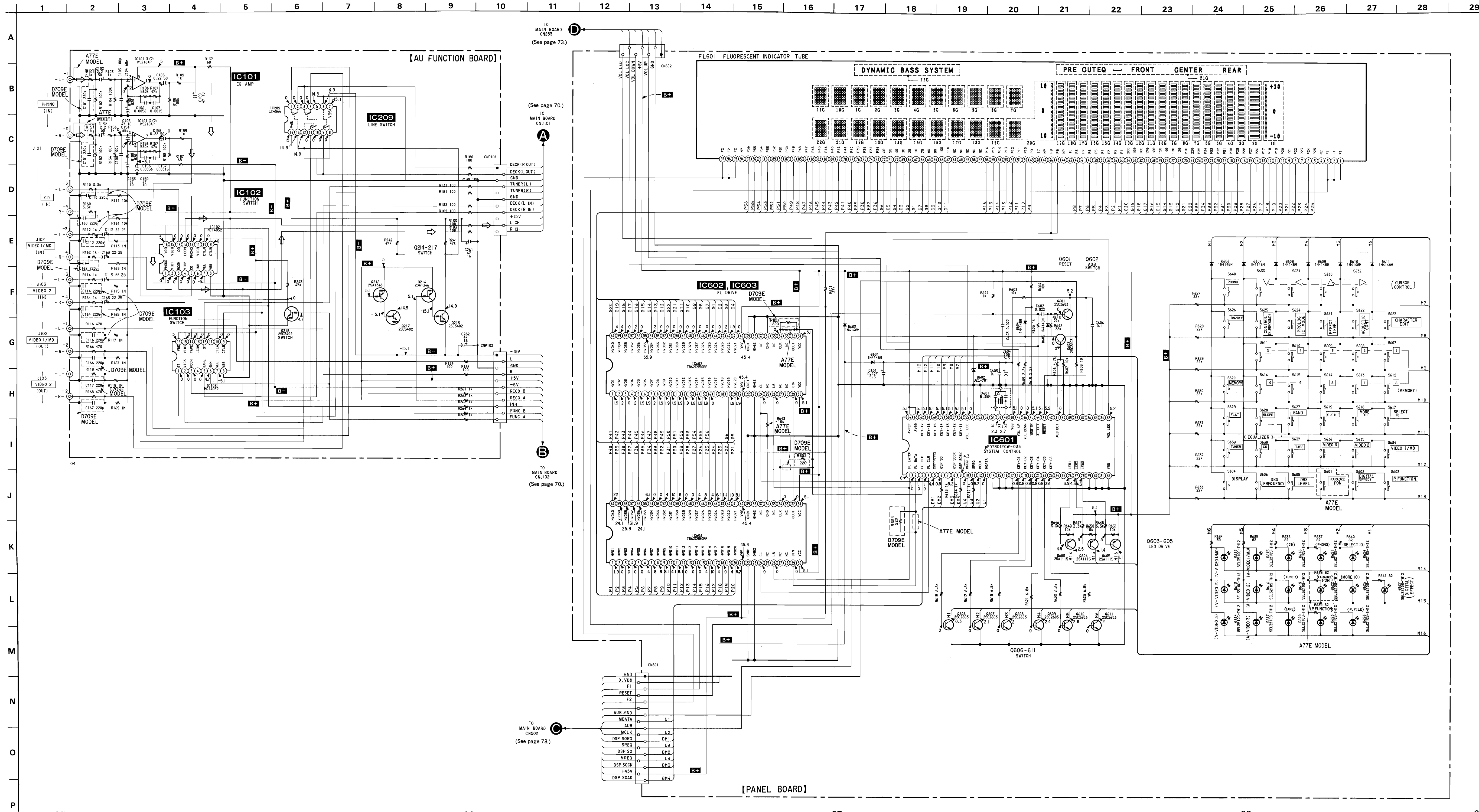

Note:

- All capacitors are in μF unless otherwise noted. pF : μF 50WV or less are not indicated except for electrolytics and tantalums.
- All resistors are in Ω and $\frac{1}{2}\text{W}$ or less unless otherwise specified.
- Δ : internal component.
- Volts are dc with respect to ground under no-signal conditions. no mark: PHONO
- Voltages are taken with a VOM (Input Impedance 10M Ω). Voltage variations may be noted due to normal production tolerances.
- Signal path.

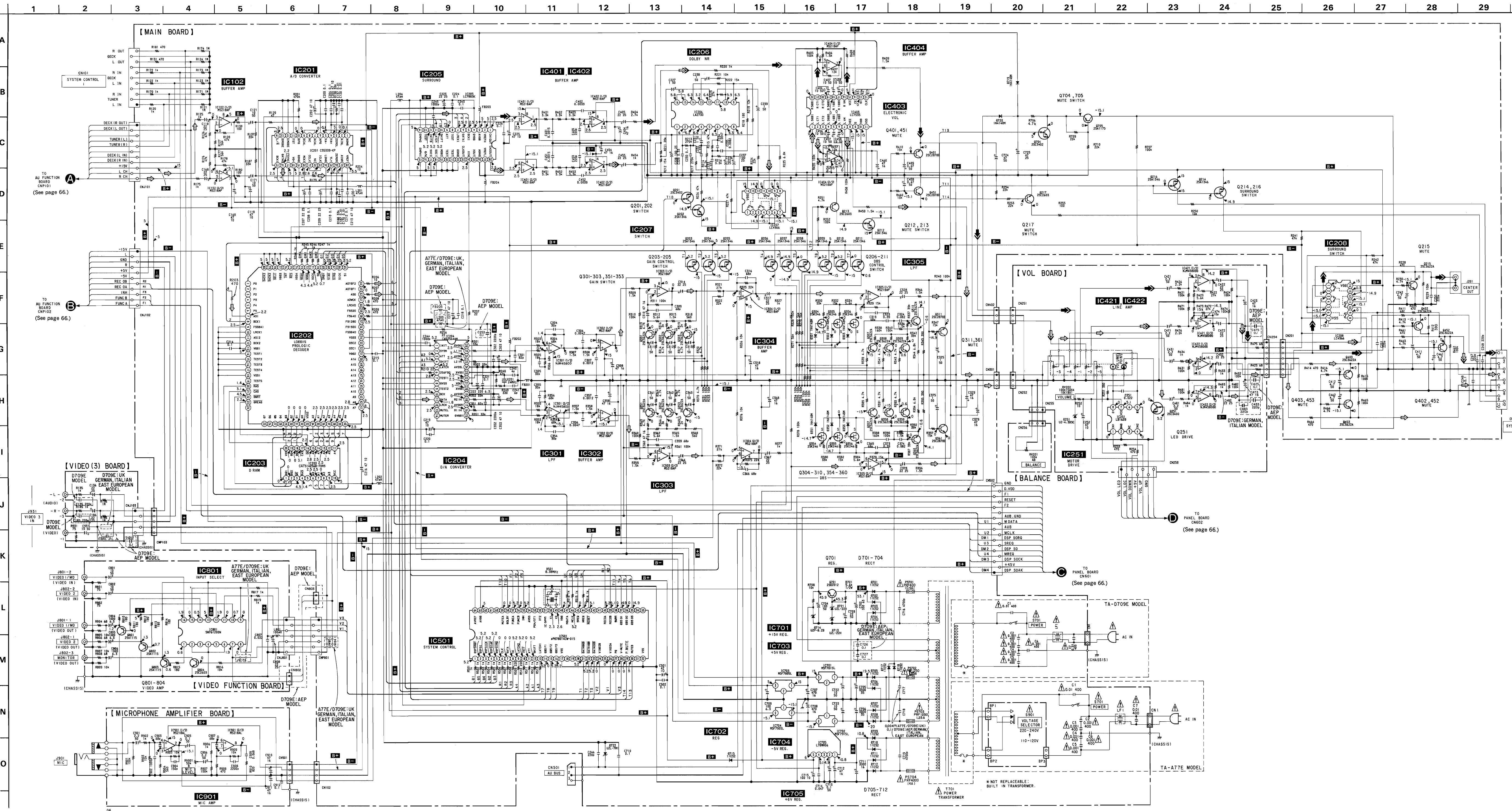

Note:

- All capacitors are in μF unless otherwise noted. pF ; μMFD 50WV or less are not indicated except for electrolytics and tantalums.
- All resistors are in Ω and $1/2W$ or less unless otherwise specified.
- Δ : internal component.

Note: The components identified by mark Δ or dotted line with mark Δ are critical for safety. Replace only with part number specified.

- Voltage is dc with respect to ground under no signal conditions. no mark: PHONO
- Voltages are taken with a VOM (Input Impedance $10M\Omega$). Voltage variations may be noted due to normal production tolerances.
- Signal path
- \rightarrow : PHONO
- \rightarrow : SURROUND
- \rightarrow : CENTER

3-20. PRINTED WIRING BOARDS—MAIN SECTION (TYPE IV)— • Refer to page 8 for Semiconductor Lead Layouts.

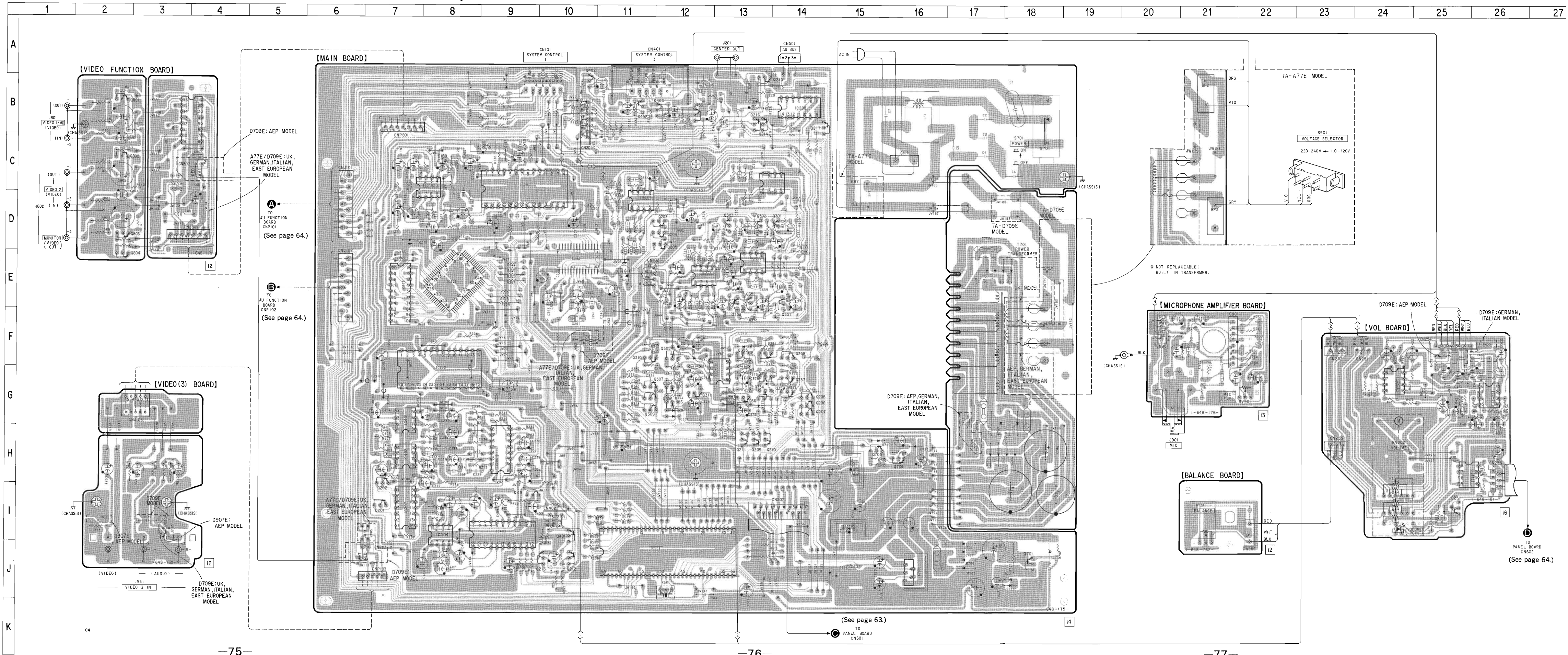

• Semiconductor Location

Ref. No.	Location	Ref. No.	Location
D251	I-25	IC801	B-3
D301	G-12	IC901	F-21
D302	F-12		
D303	G-12	Q201	I-7
D351	G-13	Q202	H-7
D352	F-13	Q203	D-12
D353	G-13	Q204	D-12
D701	J-17	Q205	D-12
D702	J-17	Q206	G-14
D703	J-17	Q207	G-14
D704	J-17	Q208	G-14
D705	H-17	Q209	H-13
D706	H-18	Q210	H-13
D707	G-17	Q211	H-13
D708	G-18	Q212	J-10
D709	E-17	Q213	J-10
D710	E-17	Q214	B-13
D711	E-17	Q215	B-13
D712	E-18	Q216	B-13
D713	J-18	Q217	B-14
D714	J-18	Q251	I-25
D715	J-14	Q301	D-14
D717	H-17	Q302	D-13
D718	H-17	Q303	D-13
D719	H-15	Q304	G-12
D720	H-16	Q305	F-12
D721	J-18	Q306	G-12
D722	B-14	Q307	G-11
		Q308	G-11
		Q309	G-11
IC102	C-8	Q310	F-11
IC201	C-9	Q311	G-12
IC202	E-8	Q351	E-14
IC203	E-7	Q352	E-13
IC204	E-10	Q353	E-13
IC205	G-8	Q354	G-13
IC206	H-9	Q355	F-13
IC207	I-7	Q356	G-13
IC208	B-14	Q357	G-14
IC251	H-25	Q358	F-14
IC301	D-11	Q359	G-14
IC302	C-13	Q360	F-13
IC303	E-13	Q361	G-13
IC304	E-12	Q401	I-10
IC305	G-13	Q402	B-10
IC401	G-7	Q403	B-12
IC402	H-7	Q451	I-9
IC403	I-9	Q452	B-11
IC404	I-8	Q453	B-12
IC421	G-24	Q701	J-18
IC422	G-26	Q704	H-16
IC501	J-12	Q705	H-15
IC701	H-15	Q801	B-2
IC702	I-15	Q802	C-2
IC703	H-11	Q803	D-2
IC704	C-9	Q804	E-2
IC705	J-16		

Note:

- — parts extracted from the component side.
- — Pattern on the side which is seen.
- — Jumper wire connected to the ground pattern on the component side.

SECTION 4 EXPLODED VIEWS

NOTE:

- The mechanical parts with no reference number in the exploded views are not supplied.
- Items marked "*" are not stocked since they are seldom required for routine service. Some delay should be anticipated when ordering these items.

- -XX and -X mean standardized parts, so they may have some difference from the original one.
- Color Indication of Appearance Parts
Example :
KNOB, BALANCE (WHITE)... (RED)
 ↑ ↑
 Parts Color Cabinet's Color

- Hardware (# mark) list is given in the last of this parts list.

The components identified by mark Δ or dotted line with mark Δ are critical for safety. Replace only with part number specified.

● Abbreviations

- G : German model
- IT : Italian model
- AUS : Australian model
- JE : Tourist model
- EA : Saudi Arabia model
- MY : Malaysia model
- SP : Singapore model
- EE : East European model

4-1. FRONT PANEL SECTION

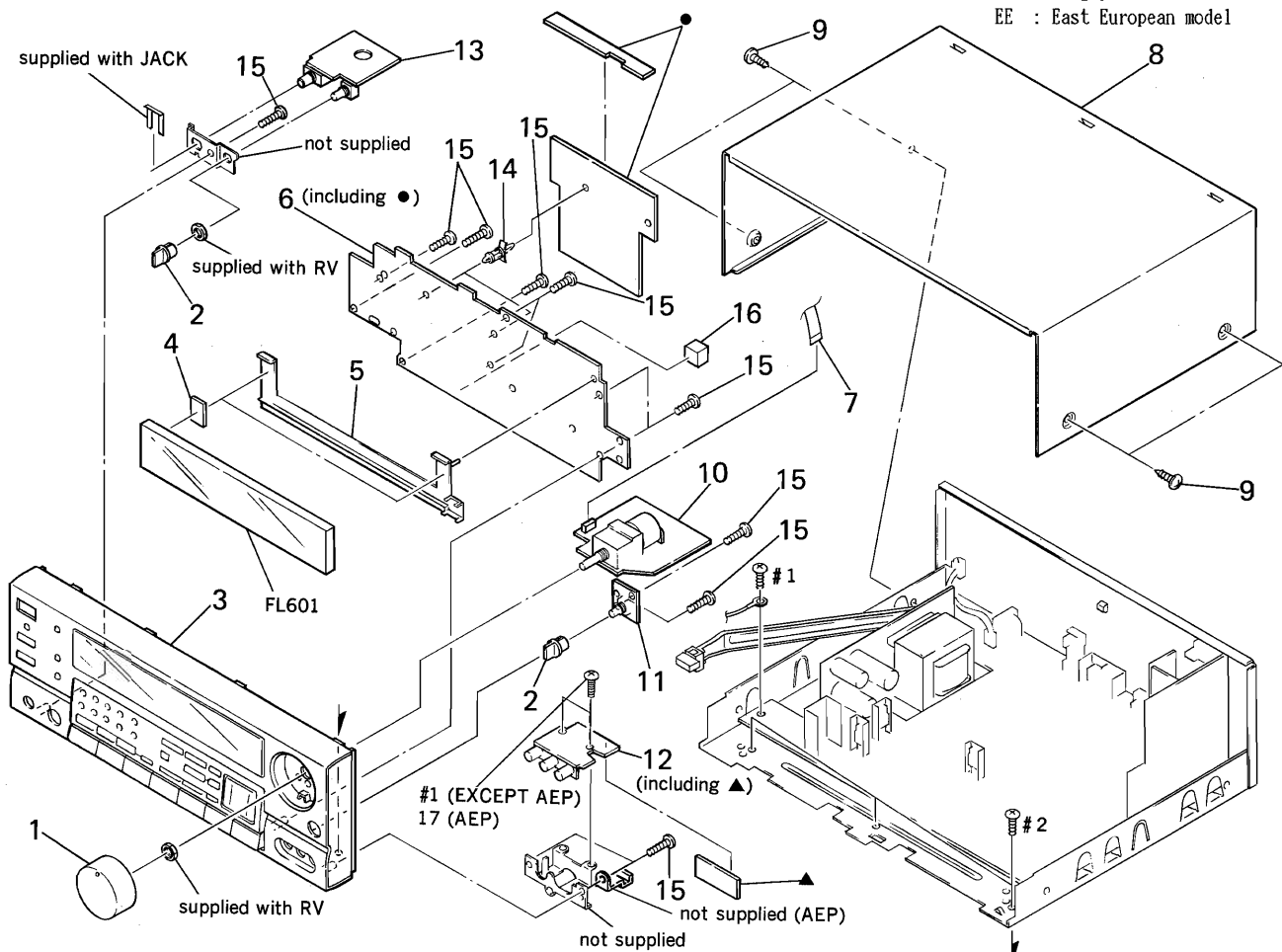

Ref. No.	Part No.	Description	Remark	Ref. No.	Part No.	Description	Remark
1	X-4943-445-1	KNOB (VOL.) ASSY		* 10	A-4360-773-A	VOL BOARD, COMPLETE (TA-A77E/TA-D709E:UK, EE)	
2	4-950-652-11	KNOB (DIA. 12), ROUND		* 10	A-4365-532-A	VOL BOARD, COMPLETE (TA-D709E:AEP)	
3	X-4943-564-1	PANEL ASSY, FRONT (TA-D709E)		* 10	A-4365-533-A	VOL BOARD, COMPLETE (TA-D709E:G, IT)	
3	X-4943-565-1	PANEL ASSY, FRONT (TA-A77E)		* 11	1-648-762-11	BALANCE BOARD	
* 4	4-934-853-01	CUSHION		* 12	1-648-180-11	VIDEO (3) BOARD	
* 5	4-957-917-01	HOLDER, FL TUBE		* 13	1-648-176-11	MICROPHONE AMPLIFIER BOARD	
* 6	A-4360-769-A	PANEL BOARD, COMPLETE (TA-D709E)		14	4-924-098-91	HOLDER, PC BOARD	
* 6	A-4360-952-A	PANEL BOARD, COMPLETE (TA-A77E)		15	4-951-620-01	SCREW (2. 6X8), +BVT	
7	1-690-420-11	WIRE, FLAT TYPE (7 CORE) (TA-D709E:EE)		16	4-608-466-01	SPACER	
7	1-690-635-11	WIRE, FLAT TYPE (7 CORE) (TA-A77E/TA-D709E:AEP, UK, G, IT)		17	4-886-821-11	SCREW, S TIGHT, +PTTWH 3X6 (TA-D709E:AEP)	
* 8	4-939-803-31	CASE		FL601	1-517-167-11	INDICATOR TUBE, FLUORESCENT	
9	3-363-099-01	SCREW (CASE 3 TP2)					

4-2. CHASSIS SECTION

The components identified by mark \triangle or dotted line with mark \triangle are critical for safety. Replace only with part number specified.

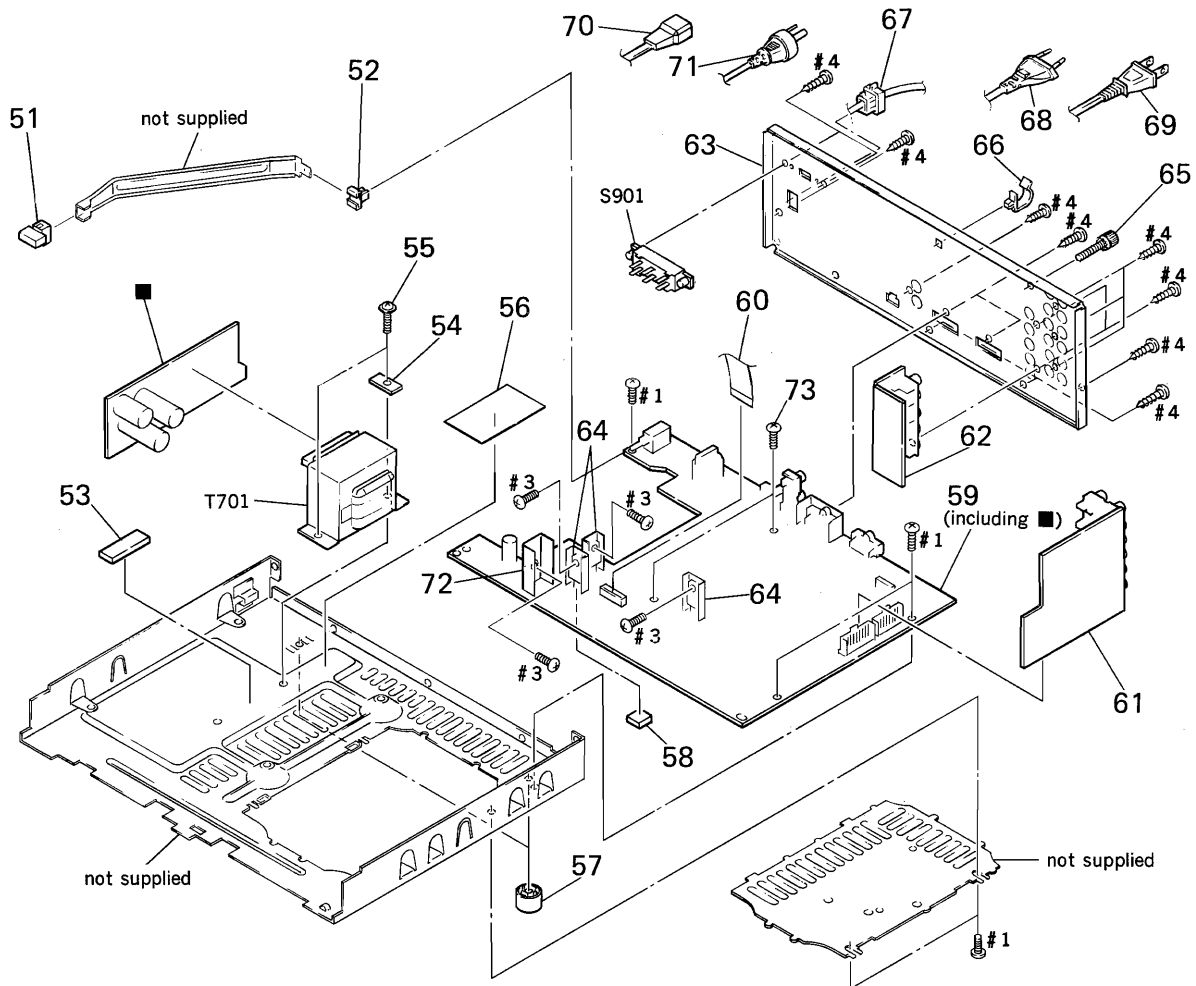

Ref. No.	Part No.	Description	Remark
51	4-942-061-11	BUTTON (P)	
52	4-866-342-00	JOINT (B), KNOB	
* 53	4-931-174-01	SPACER	
54	4-946-540-01	WASHER (SQUARE)	
55	4-946-541-01	SCREW (4X8), +PWHTT	
* 56	4-945-761-11	SHEET (INSULATING)	
57	4-931-169-01	FOOT	
58	9-911-841-XX	CUSHION	
* 59	A-4360-765-A	MAIN BOARD, COMPLETE (TA-D709E:G, IT, EE)	
* 59	A-4360-766-A	MAIN BOARD, COMPLETE (TA-A77E)	
* 59	A-4360-768-A	MAIN BOARD, COMPLETE (TA-D709E:UK)	
* 59	A-4365-527-A	MAIN BOARD, COMPLETE (TA-D709E:AEP)	
60	1-751-486-11	WIRE (FLAT TYPE) (17 CORE)	
* 61	A-4360-770-A	AU FUNCTION BOARD, COMPLETE (TA-A77E)	
* 61	A-4360-774-A	AU FUNCTION BOARD, COMPLETE (TA-D709E:UK, G, IT, EE)	
* 61	A-4365-529-A	AU FUNCTION BOARD, COMPLETE (TA-D709E:AEP)	
* 62	A-4360-771-A	VIDEO FUNCTION BOARD, COMPLETE (TA-A77E/TA-D709E:UK, G, IT, EE)	
* 62	A-4365-530-A	VIDEO FUNCTION BOARD, COMPLETE (TA-D709E:AEP)	

Ref. No.	Part No.	Description	Remark
* 63	4-957-918-01	PANEL (B3120), BACK (TA-D709E:AEP, IT, EE)	
* 63	4-957-918-11	PANEL (B3120), BACK (TA-D709E:AEP)	
* 63	4-957-918-21	PANEL (B3120), BACK (TA-D709E:UK)	
* 63	4-957-918-31	PANEL (B3120), BACK (TA-D709E:G)	
* 63	4-957-918-41	PANEL (B3120), BACK (TA-A77E:E, AUS, JE)	
* 63	4-957-918-51	PANEL (B3120), BACK (TA-A77E:EA, MY, SP)	
* 64	3-309-144-21	HEAT SINK	
65	4-947-010-01	SCREW, FEEDER FIXED	
* 66	4-949-235-01	HOOK	
* 67	3-703-244-00	BUSHING (2104), CORD (TA-A77E:EA, AUS, MY, SP/TA-D709E)	
* 67	3-703-571-11	BUSHING (S) (4516), CORD (TA-A77E:E, JE)	
\triangle 68	1-575-654-11	CORD, POWER (TA-A77E:EA, MY, SP/TA-D709E:AEP, G, IT, EE)	
\triangle 69	1-575-656-11	CORD, POWER (TA-A77E:E, JE)	
\triangle 70	1-575-669-21	CORD, POWER (TA-D709E:UK)	
\triangle 71	1-751-355-11	CORD, POWER (TA-A77E:AUS)	
* 72	4-880-403-11	HEAT SINK	
73	3-704-515-21	SCREW (BV/RING)	
\triangle S901	1-570-046-21	SWITCH, VOLTAGE CHANGE (VOLTAGE SELECTOR) (TA-A77E)	
\triangle T701	1-423-671-11	TRANSFORMER, POWER (TA-D709E)	
\triangle T701	1-423-672-11	TRANSFORMER, POWER (TA-A77E)	

SECTION 5 ELECTRICAL PARTS LIST

AU FUNCTION

NOTE:

- Due to standardization, replacements in the parts list may be different from the parts specified in the diagrams or the components used on the set.
- -XX and -X mean standardized parts, so they may have some difference from the original one.
- RESISTORS
All resistors are in ohms.
METAL: Metal-film resistor.
METAL OXIDE: Metal oxide-film resistor.
F: nonflammable

- Items marked "*" are not stocked since they are seldom required for routine service. Some delay should be anticipated when ordering these items.
- SEMICONDUCTORS
In each case, u: μ , for example:
uA ..: μ A. uPA..: μ PA.
uPB..: μ PB. uPC..: μ PC. uPD..: μ PD..
- CAPACITORS
uF: μ F
- COILS
uH: μ H

The components identified by mark Δ or dotted line with mark Δ are critical for safety. Replace only with part number specified.

- Abbreviations
G : German model
IT : Italian model
AUS : Australian model
JE : Tourist model
EA : Saudi Arabia model
MY : Malaysia model
SP : Singapore model
EE : East European model

When indicating parts by reference number, please include the board.

Ref. No.	Part No.	Description	Remark
*	A-4360-770-A	AU FUNCTION BOARD, COMPLETE (TA-A77E)	
*	A-4360-774-A	AU FUNCTION BOARD, COMPLETE (TA-D709E:UK, G, IT, EE)	
*	A-4365-529-A	AU FUNCTION BOARD, COMPLETE (TA-D709E:AEP)	

< CAPACITOR >			
C101	1-162-286-31	CERAMIC (TA-D709E)	220PF 10% 50V
C102	1-126-161-11	ELECT	2. 2uF 20% 50V
C103	1-164-070-11	CERAMIC	100PF 5% 50V
C104	1-164-066-11	CERAMIC	68PF 5% 50V
C105	1-126-022-11	ELECT	47uF 20% 10V
C106	1-130-480-00	MYLAR	0. 0056uF 5% 50V
C107	1-130-473-00	MYLAR	0. 0015uF 5% 50V
C108	1-124-464-11	ELECT	0. 22uF 20% 50V
C109	1-126-022-11	ELECT	47uF 20% 10V
C110	1-162-286-31	CERAMIC (TA-D709E)	220PF 10% 50V
C112	1-162-286-31	CERAMIC (TA-D709E)	220PF 10% 50V
C113	1-126-049-11	ELECT	22uF 20% 25V
C114	1-162-286-31	CERAMIC (TA-D709E)	220PF 10% 50V
C115	1-126-049-11	ELECT	22uF 20% 25V
C116	1-162-286-31	CERAMIC (TA-D709E)	220PF 10% 50V
C117	1-162-286-31	CERAMIC (TA-D709E)	220PF 10% 50V
C151	1-162-286-31	CERAMIC (TA-D709E)	220PF 10% 50V
C152	1-126-161-11	ELECT	2. 2uF 20% 50V
C153	1-164-070-11	CERAMIC	100PF 5% 50V
C154	1-164-066-11	CERAMIC	68PF 5% 50V
C155	1-126-022-11	ELECT	47uF 20% 10V
C156	1-130-480-00	MYLAR	0. 0056uF 5% 50V
C157	1-130-473-00	MYLAR	0. 0015uF 5% 50V
C158	1-124-464-11	ELECT	0. 22uF 20% 50V
C159	1-126-022-11	ELECT	47uF 20% 10V
C160	1-162-286-31	CERAMIC (TA-D709E)	220PF 10% 50V

Ref. No.	Part No.	Description	Remark
C162	1-162-286-31	CERAMIC (TA-D709E)	220PF 10% 50V
C163	1-126-049-11	ELECT	22uF 20% 25V
C164	1-162-286-31	CERAMIC (TA-D709E)	220PF 10% 50V
C165	1-126-049-11	ELECT	22uF 20% 25V
C166	1-162-286-31	CERAMIC (TA-D709E)	220PF 10% 50V
C167	1-162-286-31	CERAMIC (TA-D709E)	220PF 10% 50V
C261	1-126-022-11	ELECT	47uF 20% 16V
C262	1-126-022-11	ELECT	47uF 20% 16V
< CONNECTOR >			
* CNP101	1-573-979-11	CONNECTOR, BOARD TO BOARD	11P
* CNP102	1-573-979-11	CONNECTOR, BOARD TO BOARD	11P
< IC >			
IC101	8-759-636-74	IC	M5218AP-22
IC102	8-759-000-48	IC	MC14052BCP
IC103	8-759-000-48	IC	MC14052BCP
IC209	8-759-801-01	IC	LC4966
< JACK >			
J101	1-573-520-11	JACK, PIN 4P	(PHONO/CD)
J102	1-573-520-11	JACK, PIN 4P	(VIDEO 1/MD)
J103	1-573-520-11	JACK, PIN 4P	(VIDEO 2)
< TRANSISTOR >			
Q214	8-729-900-63	TRANSISTOR	DTA124ES
Q215	8-729-900-80	TRANSISTOR	DTC114ES
Q216	8-729-900-63	TRANSISTOR	DTA124ES
Q217	8-729-900-80	TRANSISTOR	DTC114ES
Q218	8-729-900-80	TRANSISTOR	DTC114ES
< RESISTOR >			
R101	1-249-417-11	CARBON (TA-D709E)	1K 5% 1/4W
R102	1-249-441-11	CARBON	100K 5% 1/4W
R103	1-249-417-11	CARBON	1K 5% 1/4W
R104	1-249-441-11	CARBON	100K 5% 1/4W
R105	1-249-416-11	CARBON	820 5% 1/4W

AU FUNCTION

BALANCE

MAIN

Ref. No.	Part No.	Description	Remark
R106	1-247-897-11	CARBON	560K 5% 1/4W
R107	1-249-437-11	CARBON	47K 5% 1/4W
R108	1-249-441-11	CARBON	100K 5% 1/4W
R109	1-249-417-11	CARBON	1K 5% 1/4W
R110	1-249-423-11	CARBON	3.3K 5% 1/4W
R111	1-249-429-11	CARBON	10K 5% 1/4W
R112	1-249-417-11	CARBON	1K 5% 1/4W
R113	1-247-903-00	CARBON	1M 5% 1/4W
R114	1-249-417-11	CARBON	1K 5% 1/4W
R115	1-247-903-00	CARBON	1M 5% 1/4W
R116	1-249-413-11	CARBON	470 5% 1/4W
R117	1-247-903-00	CARBON	1M 5% 1/4W
R118	1-249-413-11	CARBON	470 5% 1/4W
R119	1-247-903-00	CARBON	1M 5% 1/4W
R130-134	1-247-807-31	CARBON	100 5% 1/4W
R137	1-249-403-11	CARBON	68 5% 1/4W
R151	1-249-417-11	CARBON (TA-D709E)	1K 5% 1/4W
R152	1-249-441-11	CARBON	100K 5% 1/4W
R153	1-249-417-11	CARBON	1K 5% 1/4W
R154	1-249-441-11	CARBON	100K 5% 1/4W
R155	1-249-416-11	CARBON	820 5% 1/4W
R156	1-247-897-11	CARBON	560K 5% 1/4W
R157	1-249-437-11	CARBON	47K 5% 1/4W
R158	1-249-441-11	CARBON	100K 5% 1/4W
R159	1-249-417-11	CARBON	1K 5% 1/4W
R160	1-249-423-11	CARBON	3.3K 5% 1/4W
R161	1-249-429-11	CARBON	10K 5% 1/4W
R162	1-249-417-11	CARBON	1K 5% 1/4W
R163	1-247-903-00	CARBON	1M 5% 1/4W
R164	1-249-417-11	CARBON	1K 5% 1/4W
R165	1-247-903-00	CARBON	1M 5% 1/4W
R166	1-249-413-11	CARBON	470 5% 1/4W
R167	1-247-903-00	CARBON	1M 5% 1/4W
R168	1-249-413-11	CARBON	470 5% 1/4W
R169	1-247-903-00	CARBON	1M 5% 1/4W
R180-184	1-247-807-31	CARBON	100 5% 1/4W
R187	1-249-403-11	CARBON	68 5% 1/4W
R241-243	1-249-437-11	CARBON	47K 5% 1/4W
R261-265	1-249-417-11	CARBON	1K 5% 1/4W

Ref. No.	Part No.	Description	Remark
*	1-648-762-11	BALANCE BOARD ***** < VARIABLE RESISTOR >	
RV201	1-241-385-11	RES, VAR, CARBON 100K (BALANCE) *****	
*	A-4360-765-A	MAIN BOARD, COMPLETE (TA-D709E:G, IT, EE)	
*	A-4360-766-A	MAIN BOARD, COMPLETE (TA-A77E)	
*	A-4360-768-A	MAIN BOARD, COMPLETE (TA-D709E:UK)	
*	A-4365-527-A	MAIN BOARD, COMPLETE (TA-D709E:AEP) *****	
*	3-309-144-21	HEAT SINK	
*	4-870-539-00	PLATE, GROUND	
*	4-880-403-11	HEAT SINK	
*	7-682-548-04	SCREW +BVTT 3X8 (S) < BASE POST >	
BP1	1-535-139-00	BASE POST 22MM (10MM PITCH) 2P (TA-A77E)	
* BP2	1-560-595-00	TERMINAL (WITH BASE) (TA-A77E)	
* BP3	1-560-595-00	TERMINAL (WITH BASE) (TA-A77E) < CAPACITOR >	
△C1	1-161-744-51	CERAMIC	0.01uF 400V
△C2	1-161-741-00	CERAMIC	0.001uF 10% 400V
△C3	1-161-741-00	CERAMIC	0.001uF 10% 400V
△C4	1-161-741-00	CERAMIC	0.001uF 10% 400V
△C5	1-161-741-00	CERAMIC	0.001uF 10% 400V
△C6	1-161-741-00	CERAMIC	0.001uF 10% 400V
△C7	1-161-744-51	CERAMIC	0.01uF 400V
C118	1-126-049-11	ELECT	22uF 20% 25V
C119	1-126-022-11	ELECT	47uF 20% 10V
C120	1-136-153-00	FILM	0.01uF 5% 50V
C121	1-126-059-11	ELECT	10uF 20% 50V
C137	1-136-153-00	FILM	0.01uF 5% 50V
C168	1-126-049-11	ELECT	22uF 20% 25V
C169	1-126-022-11	ELECT	47uF 20% 10V
C170	1-136-153-00	FILM	0.01uF 5% 50V
C171	1-126-059-11	ELECT	10uF 20% 50V
C187	1-136-153-00	FILM	0.01uF 5% 50V
C202	1-126-022-11	ELECT	47uF 20% 10V
C203	1-164-159-11	CERAMIC	0.1uF 50V
C204	1-164-159-11	CERAMIC	0.1uF 50V
C205	1-126-022-11	ELECT	47uF 20% 10V
C207	1-126-049-11	ELECT	22uF 20% 25V
C208	1-164-159-11	CERAMIC	0.1uF 50V
C209	1-126-049-11	ELECT	22uF 20% 25V
C210	1-164-159-11	CERAMIC	0.1uF 50V
C212	1-164-159-11	CERAMIC	0.1uF 50V

The components identified by mark △ or dotted line with mark △ are critical for safety. Replace only with part number specified.

Ref. No.	Part No.	Description		Remark	
C213	1-126-022-11	ELECT	47uF	20%	10V
C214	1-164-159-11	CERAMIC	0. 1uF		50V
C215	1-164-159-11	CERAMIC	0. 1uF		50V
C216	1-126-022-11	ELECT	47uF	20%	10V
C217	1-126-022-11	ELECT	47uF	20%	10V
C218	1-164-159-11	CERAMIC	0. 1uF		50V
C219	1-126-022-11	ELECT	47uF	20%	10V
C220	1-164-159-11	CERAMIC	0. 1uF		50V
C221	1-164-159-11	CERAMIC	0. 1uF		50V
C222	1-124-587-11	ELECT	220uF	20%	6. 3V
C223	1-126-049-11	ELECT	22uF	20%	25V
C224	1-164-159-11	CERAMIC	0. 1uF		50V
C225	1-126-022-11	ELECT	47uF	20%	10V
C226	1-164-159-11	CERAMIC	0. 1uF		50V
C227	1-126-301-11	ELECT	1uF	20%	50V
C228	1-124-478-11	ELECT	100uF	20%	25V
C229	1-136-171-00	FILM	0. 33uF	5%	50V
C230	1-136-165-00	FILM	0. 1uF	5%	50V
C231	1-126-301-11	ELECT	1uF	20%	50V
C232	1-136-159-00	FILM	0. 033uF	5%	50V
C233	1-136-158-00	FILM	0. 027uF	5%	50V
C234	1-106-359-00	MYLAR	4700PF	5%	200V
C235	1-130-482-00	MYLAR	0. 0082uF	5%	50V
C236	1-126-049-11	ELECT	22uF	20%	25V
C237	1-124-478-11	ELECT	100uF	20%	25V
C238	1-126-301-11	ELECT	1uF	20%	50V
C239	1-126-301-11	ELECT	1uF	20%	50V
C240	1-164-013-11	CERAMIC	4PF	0. 25PF	50V
C241	1-164-015-11	CERAMIC	6PF	0. 5PF	50V
C242	1-126-163-11	ELECT	4. 7uF	20%	50V
C243	1-164-159-11	CERAMIC	0. 1uF		50V
C244	1-162-294-31	CERAMIC	0. 001uF	10%	50V
C245	1-162-294-31	CERAMIC	0. 001uF	10%	50V
C246	1-162-286-31	CERAMIC	220PF	10%	50V
C247	1-162-286-31	CERAMIC	220PF	10%	50V
C248	1-162-286-31	CERAMIC	220PF	10%	50V
C249	1-164-159-11	CERAMIC	0. 1uF		50V
C250	1-162-286-31	CERAMIC	220PF	10%	50V
C251	1-162-286-31	CERAMIC	220PF	10%	50V
C253	1-164-159-11	CERAMIC (TA-D709E:AEP) (TYPE III, IV)	0. 1uF		50V
C301	1-164-068-11	CERAMIC	82PF	5%	50V
C302	1-161-375-00	CERAMIC	0. 0022uF	20%	50V
C303	1-126-022-11	ELECT	47uF	20%	10V
C304	1-164-057-11	CERAMIC	30PF	5%	50V
C305	1-164-057-11	CERAMIC	30PF	5%	50V
C306	1-106-359-00	MYLAR	4700PF	5%	200V
C307	1-130-472-00	MYLAR	0. 0012uF	5%	50V
C308	1-126-022-11	ELECT	47uF	20%	16V

Ref. No.	Part No.	Description		Remark	
C309	1-164-066-11	CERAMIC	68PF	5%	50V
C310	1-126-022-11	ELECT	47uF	20%	16V
C311-313					
	1-126-301-11	ELECT	1uF	20%	50V
C314	1-126-049-11	ELECT	22uF	20%	25V
C316	1-164-066-11	CERAMIC	68PF	5%	50V
C317	1-126-049-11	ELECT	22uF	20%	25V
C318	1-126-022-11	ELECT	47uF	20%	16V
C319	1-164-066-11	CERAMIC	68PF	5%	50V
C323	1-136-841-81	FILM	0. 39uF	5%	50V
C324	1-136-164-00	FILM	0. 082uF	5%	50V
C325	1-126-301-11	ELECT	1uF	20%	50V
C328	1-126-049-11	ELECT	22uF	20%	25V
C329	1-126-022-11	ELECT	47uF	20%	16V
C351	1-164-068-11	CERAMIC	82PF	5%	50V
C352	1-161-375-00	CERAMIC	0. 0022uF	20%	50V
C353	1-126-022-11	ELECT	47uF	20%	10V
C354	1-164-057-11	CERAMIC	30PF	5%	50V
C355	1-164-057-11	CERAMIC	30PF	5%	50V
C356	1-106-359-00	MYLAR	4700PF	5%	200V
C357	1-130-472-00	MYLAR	0. 0012uF	5%	50V
C358	1-126-022-11	ELECT	47uF	20%	16V
C359	1-164-066-11	CERAMIC	68PF	5%	50V
C360	1-126-022-11	ELECT	47uF	20%	16V
C361-363					
	1-126-301-11	ELECT	1uF	20%	50V
C364	1-126-049-11	ELECT	22uF	20%	25V
C366	1-164-066-11	CERAMIC	68PF	5%	50V
C367	1-126-049-11	ELECT	22uF	20%	25V
C368	1-126-022-11	ELECT	47uF	20%	16V
C369	1-164-066-11	CERAMIC	68PF	5%	50V
C373	1-136-841-81	FILM	0. 39uF	5%	50V
C374	1-136-164-00	FILM	0. 082uF	5%	50V
C375	1-126-301-11	ELECT	1uF	20%	50V
C378	1-126-049-11	ELECT	22uF	20%	25V
C379	1-126-022-11	ELECT	47uF	20%	16V
C401	1-106-347-00	MYLAR	1500PF	5%	200V
C402	1-130-478-00	MYLAR	0. 0039uF	5%	50V
C403	1-164-077-11	CERAMIC	220PF	10%	50V
C404	1-126-022-11	ELECT	47uF	20%	16V
C405	1-126-049-11	ELECT	22uF	20%	25V
C406-408					
	1-126-059-11	ELECT	10uF	20%	50V
C409	1-126-300-11	ELECT	0. 47uF	20%	50V
C410	1-126-022-11	ELECT	47uF	20%	16V
C411	1-126-163-11	ELECT	4. 7uF	20%	50V
C412	1-126-163-11	ELECT	4. 7uF	20%	50V
C451	1-106-347-00	MYLAR	1500PF	5%	200V
C452	1-130-478-00	MYLAR	0. 0039uF	5%	50V

MAIN

Ref. No.	Part No.	Description	Remark
C453	1-164-077-11	CERAMIC	220PF 10% 50V
C454	1-126-022-11	ELECT	47uF 20% 16V
C455	1-126-049-11	ELECT	22uF 20% 25V
C456-458	1-126-059-11	ELECT	10uF 20% 50V
C459	1-126-300-11	ELECT	0.47uF 20% 50V
C460	1-126-022-11	ELECT	47uF 20% 16V
C461	1-126-163-11	ELECT	4.7uF 20% 50V
C462	1-126-163-11	ELECT	4.7uF 20% 50V
C501	1-126-022-11	ELECT	47uF 20% 10V
C502	1-164-159-11	CERAMIC	0.1uF 50V
C702	1-124-920-11	ELECT	330uF 20% 63V
C703	1-126-233-11	ELECT	22uF 20% 50V
C704	1-124-122-11	ELECT	100uF 20% 50V
C705	1-126-860-11	ELECT	3300uF 20% 35V
C706	1-126-860-11	ELECT	3300uF 20% 35V
C707	1-126-012-11	ELECT	470uF 20% 16V
C708	1-126-012-11	ELECT	470uF 20% 16V
C709	1-124-443-00	ELECT	100uF 20% 10V
C710	1-164-159-11	CERAMIC	0.1uF 50V
C711	1-124-887-00	ELECT	3300uF 20% 16V
C712	1-126-022-11	ELECT	47uF 20% 16V
C713	1-124-463-00	ELECT	0.1uF 20% 50V
C714	1-136-161-00	FILM	0.047uF 5% 50V
C715	1-124-994-11	ELECT	100uF 20% 10V
C716	1-161-377-00	CERAMIC	0.0047uF 30% 50V
C717	1-161-377-00	CERAMIC (TYPE I, II)	0.0047uF 30% 50V
C717	1-161-377-00	CERAMIC (TA-A77E/TA-D709E:UK) (TYPE III, IV)	0.0047uF 30% 50V
C717	1-164-159-11	CERAMIC (TA-D709E:AEP, G, IT, EE) (TYPE III, IV)	0.1uF 50V
C718	1-161-377-00	CERAMIC (TYPE I, II)	0.0047uF 30% 50V
C718	1-161-377-00	CERAMIC (TA-A77E/TA-D709E:UK) (TYPE III, IV)	0.0047uF 30% 50V
C718	1-164-159-11	CERAMIC (TA-D709E:AEP, G, IT, EE) (TYPE III, IV)	0.1uF 50V
C719	1-161-377-00	CERAMIC	0.0047uF 30% 50V
C722	1-126-059-11	ELECT	10uF 20% 50V
C723	1-126-059-11	ELECT	10uF 20% 50V
C724	1-124-910-11	ELECT	47uF 20% 50V
C725	1-124-910-11	ELECT	47uF 20% 50V
C726	1-136-165-00	FILM (TA-D709E:AEP, G, IT, EE) (TYPE II, III, IV)	0.1uF 5% 50V
C727	1-136-165-00	FILM (TA-D709E:AEP, G, IT, EE) (TYPE II, III, IV)	0.1uF 5% 50V

Ref. No.	Part No.	Description	Remark
		< CONNECTOR >	
* CN1	1-564-321-00	PIN, CONNECTOR 2P	
* CN101	1-566-858-41	SOCKET, CONNECTOR 11P (SYSTEM CONTROL 1)	
* CN102	1-564-507-11	PLUG, CONNECTOR 4P	
CN201	1-564-510-11	PLUG, CONNECTOR 7P	
* CN301	1-564-506-11	PLUG, CONNECTOR 3P	
* CN401	1-566-858-31	SOCKET, CONNECTOR 11P (SYSTEM CONTROL 3)	
* CN402	1-564-506-11	PLUG, CONNECTOR 3P	
* CN501	1-565-561-11	PIN, CONNECTOR 3P (AU BUS)	
* CN502	1-568-836-11	SOCKET, CONNECTOR 17P	
CN803	1-564-505-11	PLUG, CONNECTOR 2P (TA-D709E:AEP) (TYPE III, IV)	
* CNJ101	1-573-978-11	CONNECTOR, BOARD TO BOARD 11P	
* CNJ102	1-573-978-11	CONNECTOR, BOARD TO BOARD 11P	
* CNP103	1-565-967-11	PIN, CONNECTOR (PC BOARD) 5P	
CNP801	1-569-493-11	SOCKET, CONNECTOR 7P	
		< DIODE >	
D301-303	8-719-987-63	DIODE 1N4148M	
D351-353	8-719-987-63	DIODE 1N4148M	
D701-712	8-719-200-82	DIODE 11ES2	
D713	8-719-002-30	DIODE UZL-22H	
D714	8-719-014-98	DIODE UZP-8.2B	
D715	8-719-200-82	DIODE 11ES2	
D717	8-719-200-82	DIODE 11ES2	
D718	8-719-200-82	DIODE 11ES2	
D719	8-719-987-63	DIODE 1N4148M	
D720	8-719-987-63	DIODE 1N4148M	
D721	8-719-002-30	DIODE UZL-22H	
D722	8-719-000-84	DIODE UZL-7M1	
		< COIL >	
FB201-204	1-412-473-21	INDUCTOR OUH	
FB205	1-412-473-51	INDUCTOR OUH (TA-D709E:AEP) (TYPE III, IV)	
		< IC >	
IC102	8-759-711-35	IC NJM4580D	
IC201	8-759-504-36	IC CS5339-KP	
IC202	8-759-075-34	IC LC83015	
IC203	8-759-158-10	IC CAT514256B-70RS	
IC204	8-752-359-50	IC CXD2564AM	
IC205	8-759-040-59	IC LC7883K	
IC206	8-759-823-24	IC LA2730	
IC207	8-759-801-01	IC LC4966	

Ref. No.	Part No.	Description	Remark
IC208	8-759-801-01	IC LC4966	
IC301	8-759-634-51	IC M5218AP (TYPE I)	
IC301	8-759-711-35	IC NJM4580D (TYPE II, III, IV)	
IC302-305			
	8-759-634-51	IC M5218AP	
IC401	8-759-634-51	IC M5218AP	
IC402	8-759-634-51	IC M5218AP	
IC403	8-759-820-11	IC LC7535	
IC404	8-759-634-51	IC M5218AP	
IC501	8-759-171-73	IC UPD78014CW-015	
IC701	8-759-231-59	IC TA7815S	
IC702	8-759-245-87	IC TA7915S	
IC703	8-759-231-53	IC TA7805S	
IC704	8-759-245-79	IC TA79005S	
IC705	8-759-820-13	IC L78MR06	
< JACK >			
J201	1-565-352-51	JACK, PIN 2P (CENTER OUT)	
< COIL >			
L201	1-408-417-00	INDUCTOR 47uH	
L202	1-410-517-11	INDUCTOR 47uH	
L203	1-408-417-00	INDUCTOR 47uH (TYPE I, II)	
L203	1-408-417-00	INDUCTOR 47uH (TA-A77E/TA-D709E:UK, G, IT, EE) (TYPE III, IV)	
L204	1-408-417-00	INDUCTOR 47uH	
< LINE FILTER >			
△LF1	1-424-117-11	FILTER, LINE	
< IC LINK >			
△PS701	1-532-835-41	LINK, IC (PRF400) 0.4A	
△PS702	1-532-840-41	LINK, IC (PRF1250) 1.25A	
△PS703	1-532-840-41	LINK, IC (PRF1250) 1.25A	
△PS704	1-532-845-21	LINK, IC (PRF4000) 4A	
< TRANSISTOR >			
Q201	8-729-900-80	TRANSISTOR DTC114ES	
Q202-212			
	8-729-900-63	TRANSISTOR DTA124ES	
Q213	8-729-620-05	TRANSISTOR 2SC2603-EF	
Q214	8-729-900-63	TRANSISTOR DTA124ES	
Q215	8-729-141-26	TRANSISTOR 2SC3622A-LK	
Q216	8-729-900-63	TRANSISTOR DTA124ES	
Q217	8-729-620-05	TRANSISTOR 2SC2603-EF	
Q301-303			
	8-729-141-26	TRANSISTOR 2SC3622A-LK	
Q304-306			
	8-729-224-61	TRANSISTOR 2SK246-Y	

Ref. No.	Part No.	Description	Remark
Q307-311			
	8-729-141-26	TRANSISTOR 2SC3622A-LK	
Q351-353			
	8-729-141-26	TRANSISTOR 2SC3622A-LK	
Q354-356			
	8-729-224-61	TRANSISTOR 2SK246-Y	
Q357-361			
	8-729-141-26	TRANSISTOR 2SC3622A-LK	
Q401-403			
	8-729-231-55	TRANSISTOR 2SC2878-AB	
Q451-453			
	8-729-231-55	TRANSISTOR 2SC2878-AB	
Q701	8-729-209-15	TRANSISTOR 2SD2012	
Q704	8-729-900-80	TRANSISTOR DTC114ES	
Q705	8-729-119-76	TRANSISTOR 2SA1175-HFE	
< RESISTOR >			
R120	1-249-417-11	CARBON 1K 5% 1/4W	
R121	1-247-903-00	CARBON 1M 5% 1/4W	
R122	1-249-417-11	CARBON 1K 5% 1/4W	
R123	1-247-903-00	CARBON 1M 5% 1/4W	
R124	1-247-903-00	CARBON 1M 5% 1/4W	
R125	1-249-417-11	CARBON 1K 5% 1/4W	
R126	1-249-437-11	CARBON 47K 5% 1/4W	
R127	1-249-438-11	CARBON 56K 5% 1/4W	
R128	1-249-437-11	CARBON 47K 5% 1/4W	
R129	1-249-401-11	CARBON 47 5% 1/4W	
R130	1-247-807-31	CARBON 100 5% 1/4W	
R131	1-249-413-11	CARBON 470 5% 1/4W	
R137	1-249-435-11	CARBON 33K 5% 1/4W	
R138	1-249-435-11	CARBON 33K 5% 1/4W	
R170	1-249-417-11	CARBON 1K 5% 1/4W	
R171	1-247-903-00	CARBON 1M 5% 1/4W	
R172	1-249-417-11	CARBON 1K 5% 1/4W	
R173	1-247-903-00	CARBON 1M 5% 1/4W	
R174	1-247-903-00	CARBON 1M 5% 1/4W	
R175	1-249-417-11	CARBON 1K 5% 1/4W	
R176	1-249-437-11	CARBON 47K 5% 1/4W	
R177	1-249-438-11	CARBON 56K 5% 1/4W	
R178	1-249-437-11	CARBON 47K 5% 1/4W	
R179	1-249-401-11	CARBON 47 5% 1/4W	
R180	1-247-807-31	CARBON 100 5% 1/4W	
R181	1-249-413-11	CARBON 470 5% 1/4W	
R187	1-249-435-11	CARBON 33K 5% 1/4W	
R188	1-249-435-11	CARBON 33K 5% 1/4W	
R201	1-247-895-00	CARBON 470K 5% 1/4W	
R203	1-249-413-11	CARBON 470 5% 1/4W	
R204	1-249-393-11	CARBON 10 5% 1/4W	
R206	1-249-393-11	CARBON 10 5% 1/4W	
R207	1-249-397-11	CARBON 22 5% 1/4W	

The components identified by mark △ or dotted line with mark △ are critical for safety. Replace only with part number specified.

MAIN

Ref. No.	Part No.	Description	Remark
R208	1-249-413-11	CARBON	470 5% 1/4W
R209	1-249-413-11	CARBON	470 5% 1/4W
R210	1-249-397-11	CARBON	22 5% 1/4W
R211	1-247-862-11	CARBON	20K 5% 1/4W
R212	1-249-429-11	CARBON (TYPE I)	10K 5% 1/4W
R212	1-249-431-11	CARBON (TYPE II, III, IV)	15K 5% 1/4W
R213	1-247-889-00	CARBON	270K 5% 1/4W
R214	1-247-850-11	CARBON	6. 2K 5% 1/4W
R215	1-249-437-11	CARBON	47K 5% 1/4W
R216	1-249-423-11	CARBON	3. 3K 5% 1/4W
R217	1-247-889-00	CARBON	270K 5% 1/4W
R218	1-249-408-11	CARBON	180 5% 1/4W
R219	1-249-430-11	CARBON	12K 5% 1/4W
R220	1-249-417-11	CARBON	1K 5% 1/4W
R221	1-249-429-11	CARBON	10K 5% 1/4W
R222	1-249-431-11	CARBON	15K 5% 1/4W
R223	1-249-434-11	CARBON	27K 5% 1/4W
R224	1-249-433-11	CARBON	22K 5% 1/4W
R225	1-249-427-11	CARBON	6. 8K 5% 1/4W
R226	1-249-437-11	CARBON	47K 5% 1/4W
R227	1-249-437-11	CARBON	47K 5% 1/4W
R228	1-249-413-11	CARBON	470 5% 1/4W
R229	1-249-441-11	CARBON	100K 5% 1/4W
R230	1-249-425-11	CARBON	4. 7K 5% 1/4W
R231-240	1-249-441-11	CARBON	100K 5% 1/4W
R241	1-249-437-11	CARBON	47K 5% 1/4W
R242	1-249-437-11	CARBON	47K 5% 1/4W
R243	1-249-413-11	CARBON	470 5% 1/4W
R244-247	1-249-417-11	CARBON	1K 5% 1/4W
R248	1-249-437-11	CARBON	47K 5% 1/4W
R249	1-249-411-11	CARBON	330 5% 1/4W
R250	1-249-429-11	CARBON	10K 5% 1/4W
R251	1-249-425-11	CARBON	4. 7K 5% 1/4W
R252	1-249-441-11	CARBON	100K 5% 1/4W
R253	1-249-433-11	CARBON	22K 5% 1/4W
R254	1-249-433-11	CARBON	22K 5% 1/4W
R255	1-247-807-31	CARBON	100 5% 1/4W
R256	1-249-397-11	CARBON	22 5% 1/4W
R257	1-249-397-11	CARBON	22 5% 1/4W
R271-273	1-249-438-11	CARBON	56K 5% 1/4W
R301	1-249-435-11	CARBON	33K 5% 1/4W
R302	1-249-435-11	CARBON	33K 5% 1/4W
R303	1-249-432-11	CARBON	18K 5% 1/4W
R304	1-249-439-11	CARBON	68K 5% 1/4W
R305	1-249-432-11	CARBON	18K 5% 1/4W

Ref. No.	Part No.	Description	Remark
R306	1-249-439-11	CARBON	68K 5% 1/4W
R307-309	1-249-419-11	CARBON	1. 5K 5% 1/4W
R310	1-249-441-11	CARBON	100K 5% 1/4W
R311	1-249-441-11	CARBON	100K 5% 1/4W
R312	1-249-426-11	CARBON	5. 6K 5% 1/4W
R313	1-249-425-11	CARBON	4. 7K 5% 1/4W
R314	1-249-425-11	CARBON	4. 7K 5% 1/4W
R315	1-249-419-11	CARBON	1. 5K 5% 1/4W
R316	1-247-842-11	CARBON	3K 5% 1/4W
R317	1-249-425-11	CARBON	4. 7K 5% 1/4W
R318	1-249-414-11	CARBON	560 5% 1/4W
R319	1-247-838-00	CARBON	2K 5% 1/4W
R320	1-249-425-11	CARBON	4. 7K 5% 1/4W
R321	1-249-433-11	CARBON (TYPE I)	22K 5% 1/4W
R321	1-249-434-11	CARBON (TYPE II, III, IV)	27K 5% 1/4W
R322	1-249-433-11	CARBON	22K 5% 1/4W
R325	1-249-433-11	CARBON	22K 5% 1/4W
R326	1-249-429-11	CARBON	10K 5% 1/4W
R327	1-249-417-11	CARBON	1K 5% 1/4W
R328	1-249-441-11	CARBON	100K 5% 1/4W
R329	1-249-431-11	CARBON	15K 5% 1/4W
R330	1-249-435-11	CARBON	33K 5% 1/4W
R332	1-249-431-11	CARBON	15K 5% 1/4W
R334	1-249-426-11	CARBON	5. 6K 5% 1/4W
R336	1-249-419-11	CARBON	1. 5K 5% 1/4W
R337	1-249-436-11	CARBON	39K 5% 1/4W
R338	1-247-884-11	CARBON	160K 5% 1/4W
R339	1-249-425-11	CARBON	4. 7K 5% 1/4W
R340	1-249-441-11	CARBON	100K 5% 1/4W
R341	1-249-425-11	CARBON	4. 7K 5% 1/4W
R342	1-249-436-11	CARBON	39K 5% 1/4W
R343	1-249-425-11	CARBON	4. 7K 5% 1/4W
R344	1-249-427-11	CARBON	6. 8K 5% 1/4W
R345	1-249-412-11	CARBON	390 5% 1/4W
R346	1-249-419-11	CARBON	1. 5K 5% 1/4W
R347	1-249-431-11	CARBON	15K 5% 1/4W
R351	1-249-435-11	CARBON	33K 5% 1/4W
R352	1-249-435-11	CARBON	33K 5% 1/4W
R353	1-249-432-11	CARBON	18K 5% 1/4W
R354	1-249-439-11	CARBON	68K 5% 1/4W
R355	1-249-432-11	CARBON	18K 5% 1/4W
R356	1-249-439-11	CARBON	68K 5% 1/4W
R357-359	1-249-419-11	CARBON	1. 5K 5% 1/4W
R360	1-249-441-11	CARBON	100K 5% 1/4W
R361	1-249-441-11	CARBON	100K 5% 1/4W

MAIN

MICROPHONE AMPLIFIER

Ref. No.	Part No.	Description	Remark		
R362	1-249-426-11	CARBON	5.6K	5%	1/4W
R363	1-249-425-11	CARBON	4.7K	5%	1/4W
R364	1-249-425-11	CARBON	4.7K	5%	1/4W
R365	1-249-419-11	CARBON	1.5K	5%	1/4W
R366	1-247-842-11	CARBON	3K	5%	1/4W
R367	1-249-425-11	CARBON	4.7K	5%	1/4W
R368	1-249-414-11	CARBON	560	5%	1/4W
R369	1-247-838-00	CARBON	2K	5%	1/4W
R370	1-249-425-11	CARBON	4.7K	5%	1/4W
R371	1-249-433-11	CARBON (TYPE I)	22K	5%	1/4W
R371	1-249-434-11	CARBON (TYPE II, III, IV)	27K	5%	1/4W
R372	1-249-433-11	CARBON	22K	5%	1/4W
R375	1-249-433-11	CARBON	22K	5%	1/4W
R376	1-249-429-11	CARBON	10K	5%	1/4W
R377	1-249-417-11	CARBON	1K	5%	1/4W
R378	1-249-441-11	CARBON	100K	5%	1/4W
R379	1-249-431-11	CARBON	15K	5%	1/4W
R380	1-249-435-11	CARBON	33K	5%	1/4W
R382	1-249-431-11	CARBON	15K	5%	1/4W
R384	1-249-426-11	CARBON	5.6K	5%	1/4W
R386	1-249-419-11	CARBON	1.5K	5%	1/4W
R387	1-249-436-11	CARBON	39K	5%	1/4W
R388	1-247-884-11	CARBON	160K	5%	1/4W
R389	1-249-425-11	CARBON	4.7K	5%	1/4W
R390	1-249-441-11	CARBON	100K	5%	1/4W
R391	1-249-425-11	CARBON	4.7K	5%	1/4W
R392	1-249-436-11	CARBON	39K	5%	1/4W
R393	1-249-425-11	CARBON	4.7K	5%	1/4W
R394	1-249-427-11	CARBON	6.8K	5%	1/4W
R395	1-249-412-11	CARBON	390	5%	1/4W
R396	1-249-419-11	CARBON	1.5K	5%	1/4W
R397	1-249-431-11	CARBON	15K	5%	1/4W
R401-403	1-249-423-11	CARBON	3.3K	5%	1/4W
R404	1-249-422-11	CARBON	2.7K	5%	1/4W
R405	1-249-441-11	CARBON	100K	5%	1/4W
R406	1-249-419-11	CARBON	1.5K	5%	1/4W
R407	1-249-430-11	CARBON	12K	5%	1/4W
R408	1-249-441-11	CARBON	100K	5%	1/4W
R409	1-249-419-11	CARBON	1.5K	5%	1/4W
R410	1-249-431-11	CARBON	15K	5%	1/4W
R411	1-249-415-11	CARBON	680	5%	1/4W
R412	1-249-412-11	CARBON	390	5%	1/4W
R413	1-249-425-11	CARBON	4.7K	5%	1/4W
R414	1-249-413-11	CARBON	470	5%	1/4W
R415	1-249-441-11	CARBON	100K	5%	1/4W
R416	1-249-425-11	CARBON	4.7K	5%	1/4W

Ref. No.	Part No.	Description	Remark		
R451-453	1-249-423-11	CARBON	3.3K	5%	1/4W
R454	1-249-417-11	CARBON	1K	5%	1/4W
R455	1-249-441-11	CARBON	100K	5%	1/4W
R456	1-249-419-11	CARBON	1.5K	5%	1/4W
R457	1-249-430-11	CARBON	12K	5%	1/4W
R458	1-249-441-11	CARBON	100K	5%	1/4W
R459	1-249-419-11	CARBON	1.5K	5%	1/4W
R460	1-249-431-11	CARBON	15K	5%	1/4W
R461	1-249-413-11	CARBON	470	5%	1/4W
R462	1-249-441-11	CARBON	100K	5%	1/4W
R463	1-249-425-11	CARBON	4.7K	5%	1/4W
R464	1-249-413-11	CARBON	470	5%	1/4W
R465	1-249-441-11	CARBON	100K	5%	1/4W
R466	1-249-425-11	CARBON	4.7K	5%	1/4W
R501-508	1-249-417-11	CARBON	1K	5%	1/4W
R509	1-249-409-11	CARBON	220	5%	1/4W
R510	1-249-409-11	CARBON	220	5%	1/4W
R511-516	1-249-417-11	CARBON	1K	5%	1/4W
R701	1-260-108-81	CARBON	5.6K	5%	1/2W
R706	1-249-425-11	CARBON	4.7K	5%	1/4W
R707	1-249-441-11	CARBON	100K	5%	1/4W
R708	1-249-429-11	CARBON	10K	5%	1/4W
R709	1-249-433-11	CARBON	22K	5%	1/4W
R710	1-249-433-11	CARBON	22K	5%	1/4W
< SWITCH >					
△S701	1-572-716-11	SWITCH, PUSH (AC POWER)	(POWER)		
< VIBRATOR >					
X201	1-567-970-11	VIBRATOR, CRYSTAL	(24MHz)		
X501	1-579-599-21	VIBRATOR, CERAMIC	(8.38MHz)		

*	1-648-176-11	MICROPHONE AMPLIFIER BOARD			

< CAPACITOR >					
C901	1-126-161-11	ELECT	2.2uF	20%	50V
C902	1-164-088-11	CERAMIC	0.001uF		50V
C903	1-162-219-31	CERAMIC	68PF	5%	50V
C904	1-162-284-31	CERAMIC	150PF	10%	50V
C905	1-124-463-00	ELECT	0.1uF	20%	50V
C906	1-126-161-11	ELECT	2.2uF	20%	50V
C907	1-162-219-31	CERAMIC	68PF	5%	50V
C908	1-161-375-00	CERAMIC	0.0022uF	20%	50V
C909	1-136-163-00	FILM	0.068uF	5%	50V
C910	1-126-022-11	ELECT	47uF	20%	16V

The components identified by mark △ or dotted line with mark △ are critical for safety. Replace only with part number specified.

MICROPHONE AMPLIFIER

PANEL

Ref. No.	Part No.	Description	Remark		
C911	1-126-022-11	ELECT	47uF	20%	16V
C912	1-164-159-11	CERAMIC	0.1uF		50V
< CONNECTOR >					
* CN901	1-564-507-11	PLUG, CONNECTOR 4P			
< IC >					
IC901	8-759-184-02	IC NJM2068L-D			
< JACK >					
J901	1-507-854-00	JACK, PHONE (MIC)			
< RESISTOR >					
R901	1-249-441-11	CARBON	100K	5%	1/4W
R902	1-249-417-11	CARBON	1K	5%	1/4W
R903	1-249-429-11	CARBON	10K	5%	1/4W
R904	1-249-414-11	CARBON	560	5%	1/4W
R905	1-249-429-11	CARBON	10K	5%	1/4W
R906	1-249-417-11	CARBON	1K	5%	1/4W
R907	1-249-441-11	CARBON	100K	5%	1/4W
R908	1-249-413-11	CARBON	470	5%	1/4W
R909	1-249-429-11	CARBON	10K	5%	1/4W
R910	1-249-416-11	CARBON	820	5%	1/4W
< VARIABLE RESISTOR >					
RV901	1-223-334-11	RES, VAR, CARBON 50K (MIC LEVEL)			

*	A-4360-769-A	PANEL BOARD, COMPLETE (TA-D709E)			
*	A-4360-952-A	PANEL BOARD, COMPLETE (TA-A77E)			

*	4-934-853-01	CUSHION			
*	4-957-917-01	HOLDER, FL TUBE			
< CAPACITOR >					
C601	1-104-905-11	DOUBLE LAYERS	0.22F	5.5V	
C602	1-161-494-00	CERAMIC	0.022uF		25V
C603	1-161-494-00	CERAMIC	0.022uF		25V
C604	1-126-177-11	ELECT	100uF	20%	10V
C605	1-164-159-11	CERAMIC	0.1uF		50V
C606	1-164-159-11	CERAMIC	0.1uF		50V
< CONNECTOR >					
* CN601	1-568-836-11	SOCKET, CONNECTOR 17P			
* CN602	1-568-826-11	SOCKET, CONNECTOR 7P			

Ref. No.	Part No.	Description	Remark		
< DIODE >					
D601	8-719-987-63	DIODE 1N4148M			
D602	8-719-000-84	DIODE UZL-7M1			
D603-611	8-719-987-63	DIODE 1N4148M			
D612	8-719-018-46	LED SEL3510C-CD (V-VIDEO 1/MD)			
D613	8-719-018-46	LED SEL3510C-CD (V-VIDEO 2)			
D614	8-719-018-46	LED SEL3510C-CD (V-VIDEO 3)			
D615	8-719-313-69	LED SEL3210S-CD (A-VIDEO 1/MD)			
D616	8-719-313-69	LED SEL3210S-CD (A-VIDEO 2)			
D617	8-719-313-69	LED SEL3210S-CD (A-VIDEO 3)			
D618	8-719-313-69	LED SEL3210S-CD (CD)			
D619	8-719-313-69	LED SEL3210S-CD (TUNER)			
D620	8-719-313-69	LED SEL3210S-CD (TAPE)			
D621	8-719-313-69	LED SEL3210S-CD (PHONE)			
D622	8-719-313-69	LED SEL3210S-CD (KARAOKE PON) (TA-A77E)			
D623	8-719-313-69	LED SEL3210S-CD (P. FUNCTION)			
D624	8-719-313-69	LED SEL3210S-CD (SELECT 10)			
D625	8-719-313-69	LED SEL3210S-CD (MORE 10)			
D626	8-719-313-69	LED SEL3210S-CD (P. FILE)			
D627	8-719-313-69	LED SEL3210S-CD (DIGITAL EFFECT)			
< FLUORESCENT INDICATOR >					
FL601	1-517-167-11	INDICATOR TUBE, FLUORESCENT			
< IC >					
IC601	8-759-171-72	IC UPD78012CW-033			
IC602	8-759-075-35	IC TD62C950RF			
IC603	8-759-075-35	IC TD62C950RF			
< TRANSISTOR >					
Q601	8-729-620-05	TRANSISTOR 2SC2603-EF			
Q602	8-729-620-05	TRANSISTOR 2SC2603-EF			
Q603-605	8-729-119-76	TRANSISTOR 2SA1175-HFE			
Q606-611	8-729-620-05	TRANSISTOR 2SC2603-EF			
< RESISTOR >					
R601	1-249-434-11	CARBON	27K	5%	1/4W
R603	1-249-429-11	CARBON	10K	5%	1/4W
R604	1-249-429-11	CARBON	10K	5%	1/4W
R605	1-249-417-11	CARBON	1K	5%	1/4W
R606	1-249-425-11	CARBON	4.7K	5%	1/4W
R607	1-249-429-11	CARBON	10K	5%	1/4W
R608	1-249-393-11	CARBON	10	5%	1/4W
R609	1-249-421-11	CARBON	2.2K	5%	1/4W
R610	1-249-421-11	CARBON	2.2K	5%	1/4W

Ref. No.	Part No.	Description	Remark		
R612-614					
	1-249-417-11	CARBON	1K	5%	1/4W
R615	1-249-427-11	CARBON	6.8K	5%	1/4W
R617	1-249-427-11	CARBON	6.8K	5%	1/4W
R619	1-249-427-11	CARBON	6.8K	5%	1/4W
R621	1-249-427-11	CARBON	6.8K	5%	1/4W
R623	1-249-427-11	CARBON	6.8K	5%	1/4W
R625	1-249-427-11	CARBON	6.8K	5%	1/4W
R627-633					
	1-249-433-11	CARBON	22K	5%	1/4W
R634	1-249-400-11	CARBON	39	5%	1/4W
R635-637					
	1-249-404-00	CARBON	82	5%	1/4W
R638	1-249-404-00	CARBON (TA-A77E)	82	5%	1/4W
R639-641					
	1-249-404-00	CARBON	82	5%	1/4W
R642	1-249-433-11	CARBON	22K	5%	1/4W
R643	1-249-429-11	CARBON	10K	5%	1/4W
R644	1-249-417-11	CARBON	1K	5%	1/4W
R645	1-249-433-11	CARBON	22K	5%	1/4W
R646-648					
	1-249-423-11	CARBON	3.3K	5%	1/4W
R649-651					
	1-249-429-11	CARBON	10K	5%	1/4W
R652	1-249-409-11	CARBON (TA-D709E) (TYPE III, IV)	220	5%	1/4W
R653	1-249-409-11	CARBON (TA-D709E) (TYPE III, IV)	220	5%	1/4W
R654	1-249-409-11	CARBON (TA-D709E) (TYPE III, IV)	220	5%	1/4W
		< SWITCH >			
S601	1-554-303-21	SWITCH, TACTILE (KARAOKE PON) (TA-A77E)			
S602	1-554-303-21	SWITCH, TACTILE (DIGITAL EFFECT)			
S603	1-554-303-21	SWITCH, TACTILE (P. FUNCTION)			
S604	1-554-303-21	SWITCH, TACTILE (DISPLAY)			
S605	1-554-303-21	SWITCH, TACTILE (DBS LEVEL)			
S606	1-554-303-21	SWITCH, TACTILE (DBS FREQUENCY)			
S607	1-554-303-21	SWITCH, TACTILE (1)			
S608	1-554-303-21	SWITCH, TACTILE (2)			
S609	1-554-303-21	SWITCH, TACTILE (3)			
S610	1-554-303-21	SWITCH, TACTILE (4)			
S611	1-554-303-21	SWITCH, TACTILE (5)			
S612	1-554-303-21	SWITCH, TACTILE (6)			
S613	1-554-303-21	SWITCH, TACTILE (7)			
S614	1-554-303-21	SWITCH, TACTILE (8)			
S615	1-554-303-21	SWITCH, TACTILE (9)			
S616	1-554-303-21	SWITCH, TACTILE (10)			
S617	1-554-303-21	SWITCH, TACTILE (SELECT 10)			

Ref. No.	Part No.	Description	Remark		
S618	1-554-303-21	SWITCH, TACTILE (MORE 10)			
S619	1-554-303-21	SWITCH, TACTILE (P. FILE)			
S620	1-554-303-21	SWITCH, TACTILE (MEMORY)			
S621	1-554-303-21	SWITCH, TACTILE (EFFECT LEVEL)			
S622	1-554-303-21	SWITCH, TACTILE (ACOUSTIC CONT)			
S623	1-554-303-21	SWITCH, TACTILE (CHARACTER EDIT)			
S624	1-554-303-21	SWITCH, TACTILE (PROLOGIC MODE)			
S625	1-554-303-21	SWITCH, TACTILE (CONTROL (SURROUND))			
S626	1-554-303-21	SWITCH, TACTILE (ON/OFF)			
S627	1-554-303-21	SWITCH, TACTILE (BAND (EQUALIZER))			
S628	1-554-303-21	SWITCH, TACTILE (SLOPE (EQUALIZER))			
S629	1-554-303-21	SWITCH, TACTILE (FLAT)			
S630	1-554-303-21	SWITCH, TACTILE (△ (CURSOR CONTROL))			
S631	1-554-303-21	SWITCH, TACTILE (< (CURSOR CONTROL))			
S632	1-554-303-21	SWITCH, TACTILE (> (CURSOR CONTROL))			
S633	1-554-303-21	SWITCH, TACTILE (▽ (CURSOR CONTROL))			
S634	1-554-303-21	SWITCH, TACTILE (VIDEO 1/MD)			
S635	1-554-303-21	SWITCH, TACTILE (VIDEO 2)			
S636	1-554-303-21	SWITCH, TACTILE (VIDEO 3)			
S637	1-554-303-21	SWITCH, TACTILE (TAPE)			
S638	1-554-303-21	SWITCH, TACTILE (CD)			
S639	1-554-303-21	SWITCH, TACTILE (TUNER)			
S640	1-554-303-21	SWITCH, TACTILE (PHONO)			
		< VIBRATOR >			
X601	1-579-599-21	VIBRATOR, CERAMIC (8.38MHz)			

*	1-648-180-11	VIDEO (3) BOARD			

		< CAPACITOR >			
C135	1-162-286-31	CERAMIC (TA-D709E)	220PF	10%	50V
C136	1-126-049-11	ELECT	22uF	20%	25V
C185	1-162-286-31	CERAMIC (TA-D709E)	220PF	10%	50V
C186	1-126-049-11	ELECT	22uF	20%	25V
C931	1-126-059-11	ELECT	10uF	20%	50V
C932	1-164-159-11	CERAMIC (TA-D709E:AEP) (TYPE III, IV)	0.1uF		50V
C933	1-164-159-11	CERAMIC (TA-D709E:AEP) (TYPE III, IV)	0.1uF		50V
		< CONNECTOR >			
* CNJ103	1-565-970-11	SOCKET, CONNECTOR (PC BOARD) 5P			
		< JACK >			
J931	1-580-174-41	JACK, PIN (3P FRONT) (VIDEO 3 IN)			

VIDEO (3)

VIDEO FUNCTION

VOL

Ref. No.	Part No.	Description	Remark		
< RESISTOR >					
R135	1-249-417-11	CARBON	1K	5%	1/4W
R136	1-247-903-00	CARBON	1M	5%	1/4W
R185	1-249-417-11	CARBON	1K	5%	1/4W
R186	1-247-903-00	CARBON	1M	5%	1/4W
R931	1-247-804-11	CARBON	75	5%	1/4W

*	A-4360-771-A VIDEO FUNCTION BOARD, COMPLETE (TA-A77E/TA-D709E:UK, G, IT, EE)				
*	A-4365-530-A VIDEO FUNCTION BOARD, COMPLETE (TA-D709E:AEP)				

< CAPACITOR >					
C801	1-126-059-11	ELECT	10uF	20%	50V
C802	1-126-059-11	ELECT	10uF	20%	50V
C804	1-124-471-00	ELECT	1000uF	20%	6.3V
C805	1-124-471-00	ELECT	1000uF	20%	6.3V
C806	1-124-471-00	ELECT	1000uF	20%	6.3V
C807	1-161-494-00	CERAMIC	0.022uF		25V
C808	1-126-049-11	ELECT	22uF	20%	25V
< CONNECTOR >					
CN802	1-564-505-11	PLUG, CONNECTOR 2P	(TA-D709E:AEP) (TYPE III, IV)		
* CNJ801	1-569-502-11	PIN, CONNECTOR 7P			
< IC >					
IC801	8-759-061-95	IC	SN761200N		
< JACK >					
J801	1-568-751-51	JACK, PIN (2P SHIELD TYPE)	(VIDEO 1/MD)		
J802	1-568-752-51	JACK, PIN (3P SHIELD TYPE)	(VIDEO 2/MONITOR)		
< COIL >					
L801	1-410-521-11	INDUCTOR	100uH		
< TRANSISTOR >					
Q801-803					
	8-729-119-76	TRANSISTOR	2SA1175-HFE		
Q804	8-729-620-05	TRANSISTOR	2SC2603-EF		
< RESISTOR >					
R801	1-247-804-11	CARBON	75	5%	1/4W
R802	1-247-804-11	CARBON	75	5%	1/4W
R804	1-249-403-11	CARBON	68	5%	1/4W
R805	1-249-429-11	CARBON	10K	5%	1/4W

Ref. No.	Part No.	Description	Remark		
R806	1-249-403-11	CARBON	68	5%	1/4W
R807	1-249-429-11	CARBON	10K	5%	1/4W
R808	1-249-403-11	CARBON	68	5%	1/4W
R809	1-249-429-11	CARBON	10K	5%	1/4W
R810-815	1-249-408-11	CARBON	180	5%	1/4W
R816	1-249-429-11	CARBON	10K	5%	1/4W
R817	1-249-417-11	CARBON	1K	5%	1/4W
R819	1-249-417-11	CARBON	1K	5%	1/4W

*	A-4360-773-A VOL BOARD, COMPLETE (TA-A77E/TA-D709E:UK, EE)				
*	A-4365-532-A VOL BOARD, COMPLETE (TA-D709E:AEP)				
*	A-4365-533-A VOL BOARD, COMPLETE (TA-D709E:G, IT)				

< CAPACITOR >					
C251	1-161-494-00	CERAMIC	0.022uF		25V
C252	1-126-022-11	ELECT	47uF	20%	10V
C421	1-126-161-11	ELECT	2.2uF	20%	50V
C422	1-126-049-11	ELECT	22uF	20%	25V
C423	1-126-022-11	ELECT	47uF	20%	16V
C425	1-164-159-11	CERAMIC	0.1uF		50V
(TA-D709E:AEP) (TYPE III, IV)					
C431	1-126-161-11	ELECT	2.2uF	20%	50V
C432	1-126-049-11	ELECT	22uF	20%	25V
C433	1-162-286-31	CERAMIC	220PF	10%	50V
(TA-D709E:G, IT) (TYPE II, III, IV)					
C471	1-126-161-11	ELECT	2.2uF	20%	50V
C472	1-126-049-11	ELECT	22uF	20%	25V
C473	1-126-022-11	ELECT	47uF	20%	16V
C474	1-162-199-31	CERAMIC	10PF	5%	50V
C475	1-164-159-11	CERAMIC	0.1uF		50V
(TA-D709E:AEP) (TYPE III, IV)					
C481	1-126-161-11	ELECT	2.2uF	20%	50V
C482	1-126-049-11	ELECT	22uF	20%	25V
C483	1-162-286-31	CERAMIC	220PF	10%	50V
(TA-D709E:G, IT) (TYPE II, III, IV)					
< CONNECTOR >					
* CN251	1-564-506-11	PLUG, CONNECTOR 3P			
* CN252	1-564-506-11	PLUG, CONNECTOR 3P			
* CN253	1-568-826-11	SOCKET, CONNECTOR 7P			
CN254	1-564-510-11	PLUG, CONNECTOR 7P			
CN255	1-564-506-11	PLUG, CONNECTOR 3P			
< DIODE >					
D251	8-719-010-30	DIODE	UZ-4.3BSC		

Ref. No.	Part No.	Description	Remark
< IC >			
IC251	8-759-820-62	IC LB1639	
IC421	8-759-710-59	IC NJM4580D-D	
IC422	8-759-710-59	IC NJM4580D-D	
< TRANSISTOR >			
Q251	8-729-900-36	TRANSISTOR DTC124ES	
< RESISTOR >			
R251	1-249-412-11	CARBON 390 5% 1/4W	
R252	1-249-393-11	CARBON 10 5% 1/4W	
R253	1-249-413-11	CARBON 470 5% 1/4W	
R254	1-249-413-11	CARBON 470 5% 1/4W	
R421	1-249-441-11	CARBON 100K 5% 1/4W	
R422	1-249-434-11	CARBON 27K 5% 1/4W	
R423	1-249-426-11	CARBON 5.6K 5% 1/4W	
R424	1-249-441-11	CARBON 100K 5% 1/4W	
R425	1-249-403-11	CARBON 68 5% 1/4W	
R426	1-249-421-11	CARBON 2.2K 5% 1/4W	
R431	1-249-441-11	CARBON 100K 5% 1/4W	
R432	1-249-441-11	CARBON 100K 5% 1/4W	
R433	1-249-417-11	CARBON 1K 5% 1/4W	
R434	1-249-417-11	CARBON 1K 5% 1/4W	
R471	1-249-441-11	CARBON 100K 5% 1/4W	
R472	1-249-434-11	CARBON 27K 5% 1/4W	
R473	1-249-431-11	CARBON 15K 5% 1/4W	
R474	1-249-441-11	CARBON 100K 5% 1/4W	
R475	1-249-403-11	CARBON 68 5% 1/4W	
R476	1-249-421-11	CARBON 2.2K 5% 1/4W	
R481	1-249-441-11	CARBON 100K 5% 1/4W	
R482	1-249-441-11	CARBON 100K 5% 1/4W	
R483	1-249-417-11	CARBON 1K 5% 1/4W	
R484	1-249-417-11	CARBON 1K 5% 1/4W	
< VARIABLE RESISTOR >			
RV202	1-223-389-11	RES, VAR, CARBON 10K/100KX4 (VOLUME)	

Ref. No.	Part No.	Description	Remark
MISCELLANEOUS *****			
7	1-690-420-11	WIRE, FLAT TYPE (7 CORE) (TA-D709E:EE)	
7	1-690-635-11	WIRE, FLAT TYPE (7 CORE) (TA-A77E/TA-D709E:AEP, UK, G, IT)	
60	1-751-486-11	WIRE (FLAT TYPE) (17 CORE)	
△68	1-575-654-11	CORD, POWER (TA-A77E:EA, MY, SP/TA-D709E:AEP, G, IT, EE)	
△69	1-575-656-11	CORD, POWER (TA-A77E:E, JE)	
△70	1-575-669-21	CORD, POWER (TA-D709E:UK)	
△71	1-751-355-11	CORD, POWER (TA-A77E:AUS)	
△S901	1-570-046-21	SWITCH, VOLTAGE CHANGE (VOLTAGE SELECTOR) (TA-A77E)	
△T701	1-423-671-11	TRANSFORMER, POWER (TA-D709E)	
△T701	1-423-672-11	TRANSFORMER, POWER (TA-A77E)	

HARDWARE LIST

- #1 7-682-547-09 SCREW +BVTT 3X6 (S)
- #2 7-685-646-79 SCREW +BVTP 3X8 TYPE2 N-S
- #3 7-682-548-04 SCREW +BVTT 3X8 (S)
- #4 7-621-849-00 SCREW (BV/RING)

The components identified by mark △ or dotted line with mark △ are critical for safety. Replace only with part number specified.

TA-A77E/D709E

9-957-967-12

**Sony Corporation
Audio Group**

—92—

English
9310475-1
Printed in Japan
© 1993. 9

Published by Audio Sector Quality Assurance Dept.