

TA-A X 320

SERVICE MANUAL

*US Model
Canadian Model
AEP Model
UK Model
E Model*



SPECIFICATIONS

(For the USA and Canadian models)

AUDIO POWER SPECIFICATIONS

POWER OUTPUT AND TOTAL

HARMONIC DISTORTION:

With 8 ohm loads, both channels driven, from 20 - 20,000 Hz: rated 80 watts per channel minimum RMS power, with no more than 0.08 % total harmonic distortion from 250 milliwatts to rated output.

OTHER SPECIFICATIONS

Amplifier section

Continuous RMS power output

(both channels driven simultaneously) At 1 kHz
70 + 70 watts (5% THD, 8 ohms)
(AEP, UK, E model) 60 + 60 watts (0.08% THD, 8 ohms) (AEP, UK model)

At 40 Hz - 20 kHz
55 + 55 watts (0.08% THD, 8 ohms)
According to DIN 45500 (AEP, UK model)
55 + 55 watts (8 ohms)

Peak music power output (E model)
400 watts (5% THD, 8 ohms)

Music power output (E model)
200 watts (5% THD, 8 ohms)

Power bandwidth (1HF)
10 Hz - 30 kHz

Dynamic headroom
1.2 dB ('78 IHF)

Harmonic distortion

Less than 0.08% at rated output

Intermodulation (IM) distortion
(60 Hz : 7 kHz = 4 : 1) Less than 0.08% at rated output

Frequency response

PHONO : RIAA equalization curve ± 0.5 dB
TUNER
CD
TAPE
VIDEO (audio) } 10 Hz - 100 kHz ± 2.0 dB

Residual noise Less than 100 μ V (8 ohms, network A)

Damping factor
50 (8 ohms, 1 kHz)

— Continued on page 2 —

SAFETY-RELATED COMPONENT WARNING!!

COMPONENTS IDENTIFIED BY SHADING AND MARK \triangle ON THE SCHEMATIC DIAGRAMS AND IN THE PARTS LIST ARE CRITICAL TO SAFE OPERATION. REPLACE THESE COMPONENTS WITH SONY PARTS WHOSE PART NUMBERS APPEAR AS SHOWN IN THIS MANUAL OR IN SUPPLEMENTS PUBLISHED BY SONY.

ATTENTION AU COMPOSANT AYANT RAPPORT À LA SÉCURITÉ!

LES COMPOSANTS IDENTIFIÉS PAR UNE TRAME ET UNE MARQUE \triangle SUR LES DIAGRAMMES SCHÉMATIQUES ET LA LISTE DES PIÈCES SONT CRITIQUES POUR LA SÉCURITÉ DE FONCTIONNEMENT. NE REMPLACER CES COMPOSANTS QUE PAR DES PIÈCES SONY DONT LES NUMÉROS SONT DONNÉS DANS CE MANUEL OU DANS LES SUPPLÉMENTS PUBLIÉS PAR SONY.

INTEGRATED STEREO AMPLIFIER
SONY®



Inputs

	Sensitivity	Impedance	S/N (weighting network, input level)
PHONO	2.0 mV	50 kilohms	74 dB 76 dB* (A, 2.0 mV)
TUNER CD TAPE VIDEO 1, 2 (audio)	150 mV	50 kilohms	100 dB 81 dB* (A, 150 mV)

* '78 IHF

Outputs

REC OUT

Voltage 150 mV
Impedance 4.7 kilohms

VIDEO OUT

Voltage 1 V (p-p)
Impedance 75 ohms

SPEAKER

Accepts speakers of 8 - 16 ohms.

HEADPHONES

Accepts low and high impedance headphones.

Tone controls

BASS

±10 dB at 100 Hz (turnover freq. 300 Hz)

TREBLE

±10 dB at 10 kHz (turnover freq. 3 kHz)

Bass boost control

+ 6.0 dB (60 Hz)

General System

Preamplifier section : low-noise IC NF type equalizer amplifier

Power amplifier section : quasi-complementary SEPP OTL OCL power amplifier with all stages direct coupled

Power requirements

AEP model : 220 V ac (or 240 V ac adjustable by authorized Sony personnel), 50/60 Hz

UK model : 240 V ac (or 220 V ac adjustable by authorized Sony personnel), 50 Hz

US, Canadian model : 120 V ac, 60 Hz

E model : 120, 220, or 240 V ac adjustable, 50/60 Hz

Power consumption

AEP, E model : 125 W

UK model : 120 W

US model : 135 W

Canadian model : 290 VA

AC outlets

AEP, UK model : 3 switched, total 100 watts max.

US, Canadian, E model : 2 switched, total 100 watts max. and 1 unswitched, 100 watts max.

Dimensions

AEP model : Approx. 430 × 105 × 255 mm (w/h/d) (17 × 4¹/₄ × 10¹/₈ inches)

UK, US, Canadian, E model : Approx. 430 × 105 × 250 mm (w/h/d) (17 × 4¹/₄ × 9⁷/₈ inches)

including projecting parts and controls

Weight

Approx. 5.9 kg (13 lbs) net

Approx. 6.5 kg (14 lbs 2 oz) in shipping carton

SAFETY CHECK-OUT (US Model)

After correcting the original service problem, perform the following safety check before releasing the set to the customer:

Check the antenna terminals, metal trim, "metallized" knobs, screws, and all other exposed metal parts for AC leakage. Check leakage as described below.

LEAKAGE TEST

The AC leakage from any exposed metal part to earth ground and from all exposed metal parts to any exposed metal part having a return to chassis, must not exceed 0.5 mA (500 microamperes). Leakage current can be measured by any one of three methods.

1. A commercial leakage tester, such as the Simpson 229 or RCA WT-540A. Follow the manufacturers' instructions to use these instruments.
2. A battery-operated AC milliammeter. The Data Precision 245 digital multimeter is suitable for this job.
3. Measuring the voltage drop across a resistor by means of a VOM or battery-operated AC voltmeter. The "limit" indication is 0.75 V, so analog meters must have an accurate low-voltage scale. The Simpson 250 and Sanwa SH-63Trd are examples of a passive VOM that is suitable. Nearly all battery operated digital multimeters that have a 2V AC range are suitable. (See Fig. A)

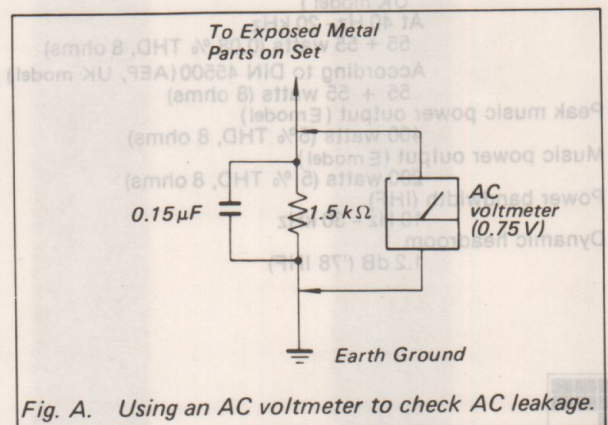
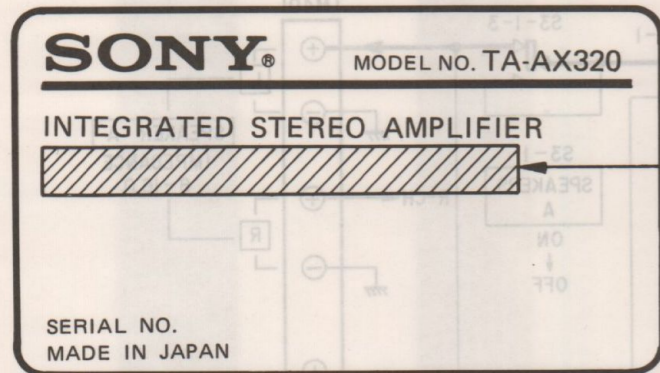

Fig. A. Using an AC voltmeter to check AC leakage.

MODEL IDENTIFICATION

- Specification Label -



- US model: AC 120V 60Hz 135W
- Canadian model: AC 120V 60Hz 290VA
- AEP, G-AEP model: AC 220V 50/60Hz 125W
- UK model: AC 240V 50Hz 120W
- E model: AC 120, 220, 240V 50/60Hz 125W

FUNCTION OF CONTROLS

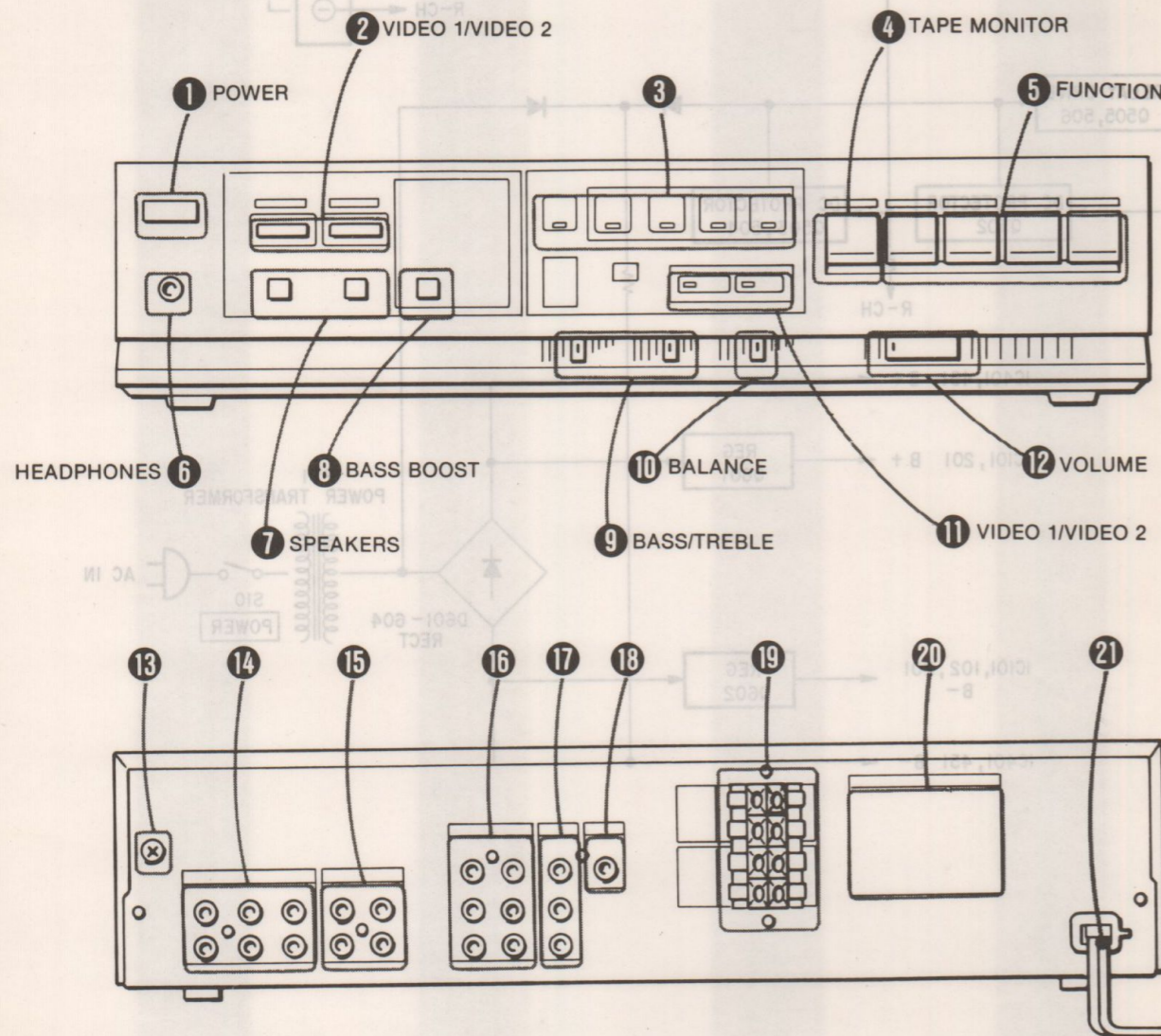

Each number in the text is keyed to that of the illustrations on page 3.

Front panel

- 1 POWER switch**
Turns the operating power on or off.
- 2 VIDEO 1/VIDEO 2 buttons**
VIDEO 1: Press this button for playback of video recorder 1.
VIDEO 2: Press this button for playback of video recorder 2, or to edit video tapes from video recorder 2 to video recorder 1.
To listen to the video sound, press the VIDEO button.
- 3 FUNCTION indicators**
Lights up according to the program source selected with FUNCTION buttons or TAPE MONITOR button.
- 4 TAPE MONITOR button**
Press this button to listen to a tape deck connected to the TAPE inputs on the rear panel. Press the button again to disengage it.
- 5 FUNCTION buttons**
Press one of these buttons to select a desired program source.
VIDEO: For listening to video programs (connected to AUDIO IN inputs).
To select the video program, press the appropriate VIDEO 1 or VIDEO 2 button.
CD: For compact disc programs (connected to CD inputs).
TUNER: For broadcasting programs (connected to TUNER inputs).
PHONO: For record programs (connected to PHONO inputs).
- 6 HEADPHONES jack**
Accepts any low or high impedance stereo headphones.
For headphone monitoring only, keep both SPEAKERS selectors released.
- 7 SPEAKERS selectors**
Select speaker system A or B, or both.
- 8 BASS BOOST switch**
Set this switch to ON to reinforce the bass response.
- 9 TREBLE and BASS tone controls**
These knobs control the treble and bass response. Slide towards the right (+10) to increase the response and towards the left (-10) to decrease the response.
- 10 BALANCE control**
Governs the amount of sound coming from each speaker to get optimum stereo effect.
Slide towards RIGHT to decrease the left channel volume, and slide towards LEFT to decrease the right channel.

11 VIDEO 1/VIDEO 2 indicators

Light up when you press the VIDEO 1 or VIDEO 2 button.

12 VOLUME control

Regulates the overall sound level. Slide towards the right (MAX) to increase the sound level and towards the left (MIN) to decrease it.

Rear panel

13 Ground terminal

To prevent hum, be sure to connect the ground wire of the record player to this ground terminal. If hum still exists, it may be helpful to connect the ground terminal directly to earth via a ground rod.

14 INPUT jacks (phono jack)

PHONO: Accept the outputs of a turntable system.
TUNER: Accept the outputs of a tuner.
CD: Accept the outputs of a CD player.

15 TAPE RECORDER inputs/outputs (phono jack)

TAPE: Accept the line outputs of a tape deck for playing back.
REC OUT: Accept the inputs of a tape deck for recording.

16 VIDEO 1 inputs/outputs

VIDEO OUT (phono jack): Accepts the video input of a video recorder.
AUDIO OUT (phono jack): Accept the audio inputs of a video recorder for recording.
VIDEO IN (phono jack): Accepts the video output of a video recorder.
AUDIO IN (phono jack): Accept the audio outputs of a video recorder for playback.

17 VIDEO 2 inputs

VIDEO IN (phono jack): Accepts the video output of a TV tuner for multiple video source connection, monaural video recorder or second video recorder for video editing.
AUDIO IN (phono jack): Accept the audio outputs of a TV tuner for multiple video source connection, monaural video recorder or second video recorder for video editing.

18 MONITOR VIDEO OUT output (phono jack)

Accepts the input of a color monitor.

19 SPEAKER A, B connectors

For connecting a pair of speaker system, or two pairs of speaker systems. System A and system B can be selected by means of the front panel SPEAKERS selectors.

20 AC OUTLETS

These are used to power other audio components whose power consumption is less than the wattage indicated on the ac outlet.

21 Power cord

SECTION 1
BLOCK DIAGRAM

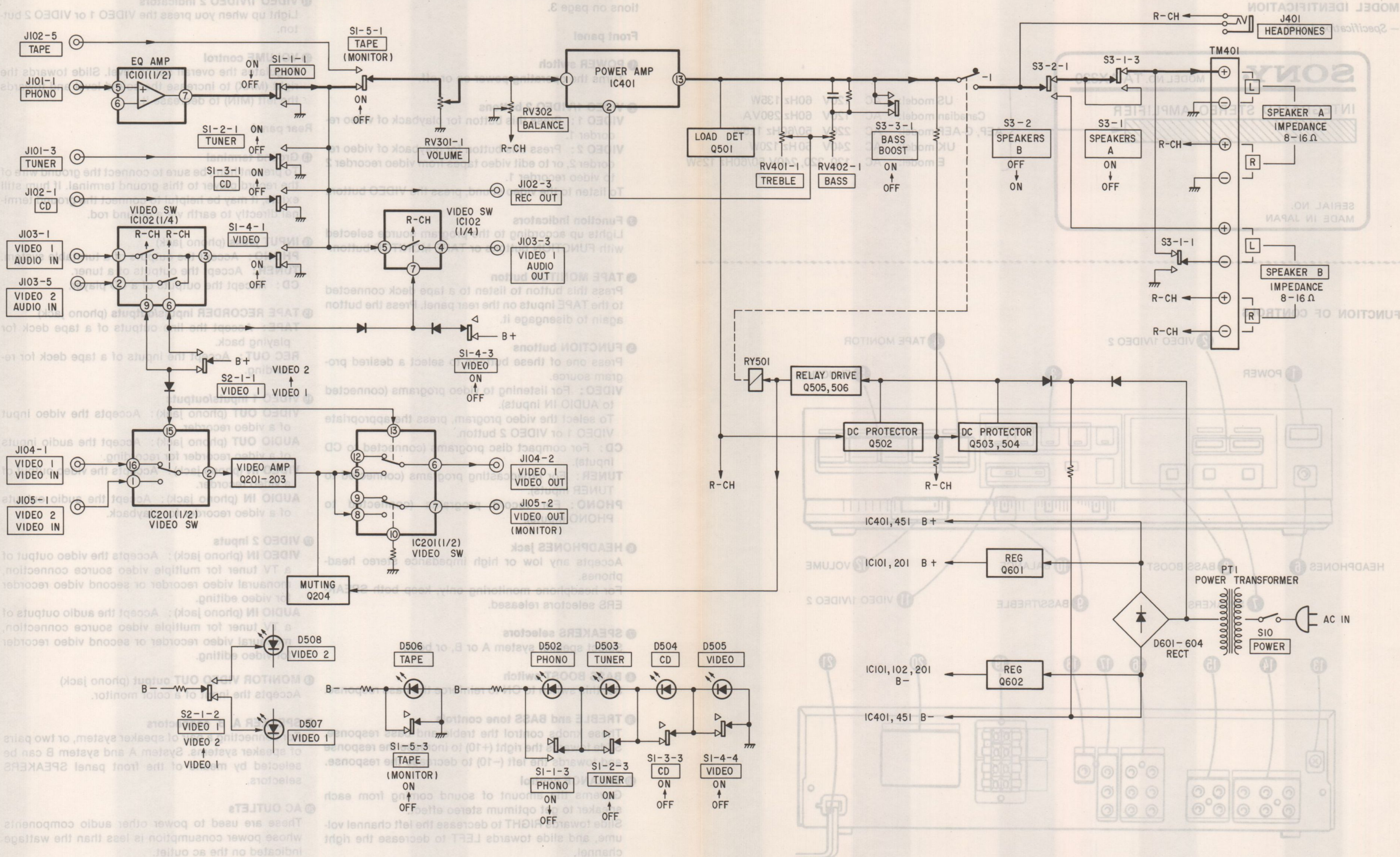

SECTION 2

DISASSEMBLY

Remove top cover. • Follow the disassembly procedure in the numerical order given.

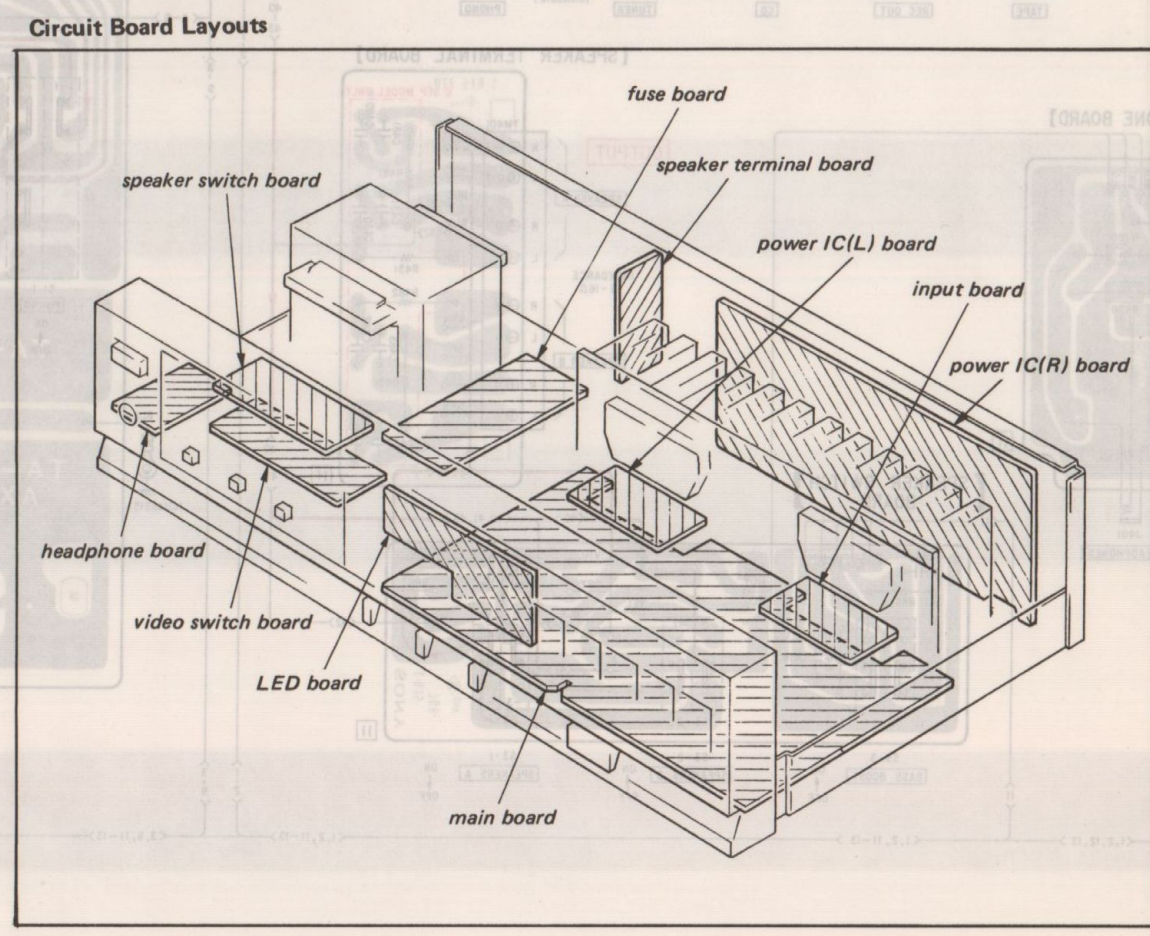
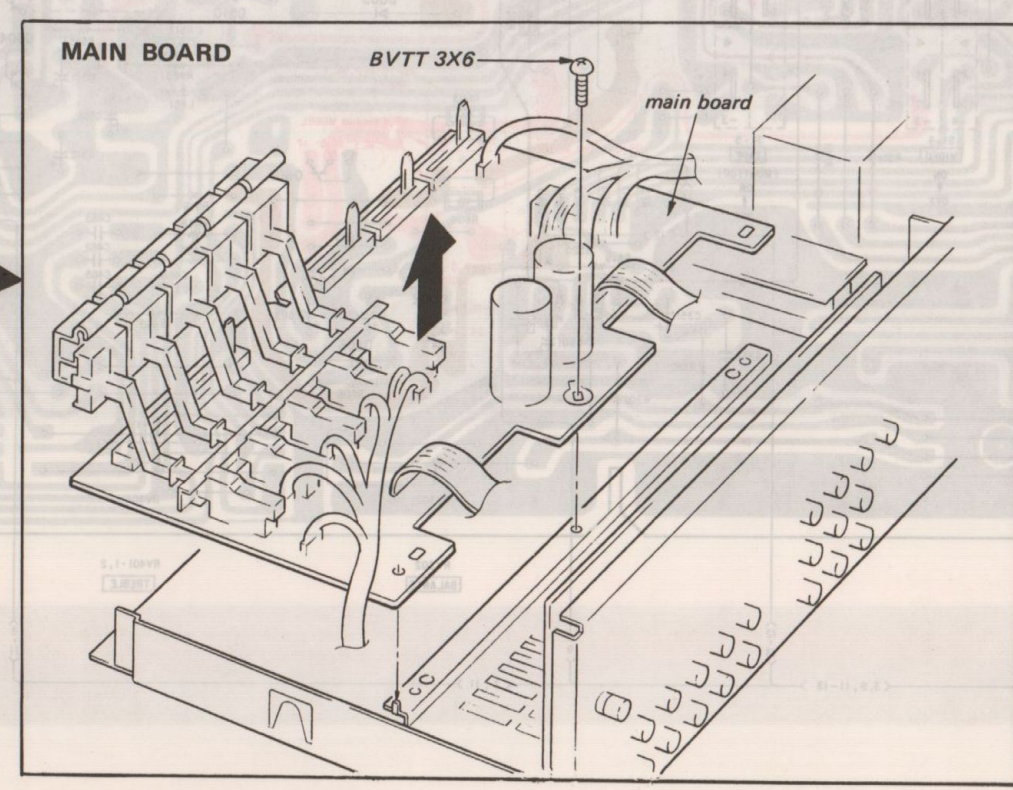
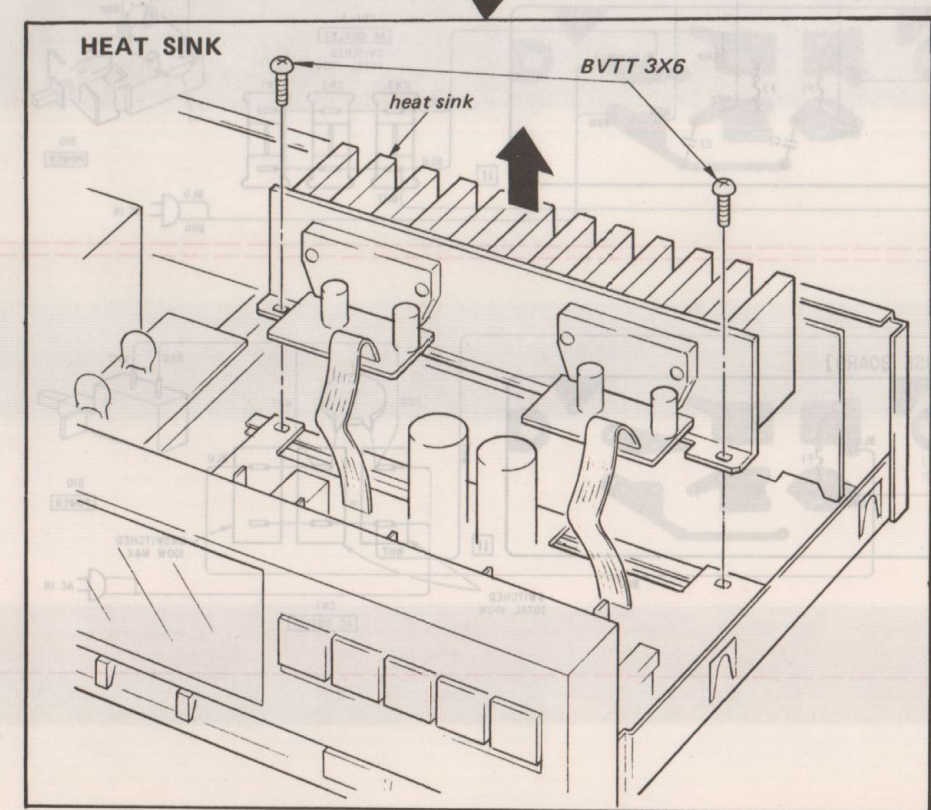
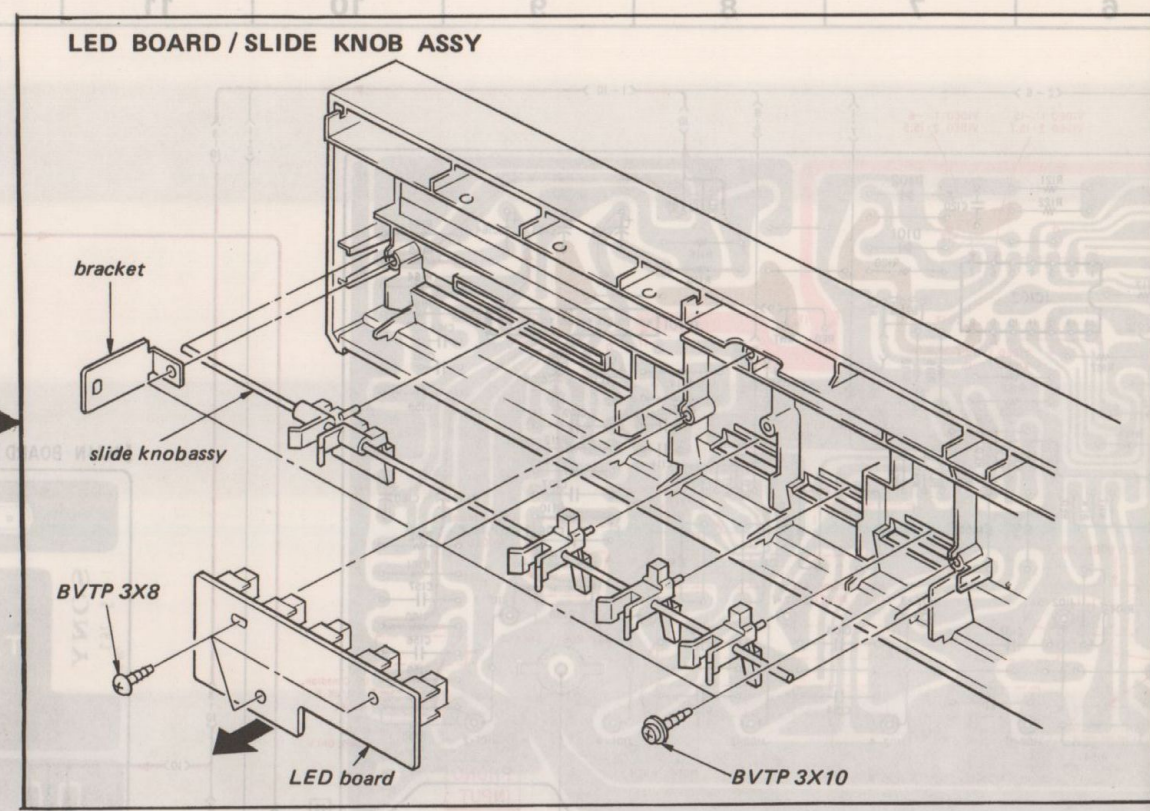
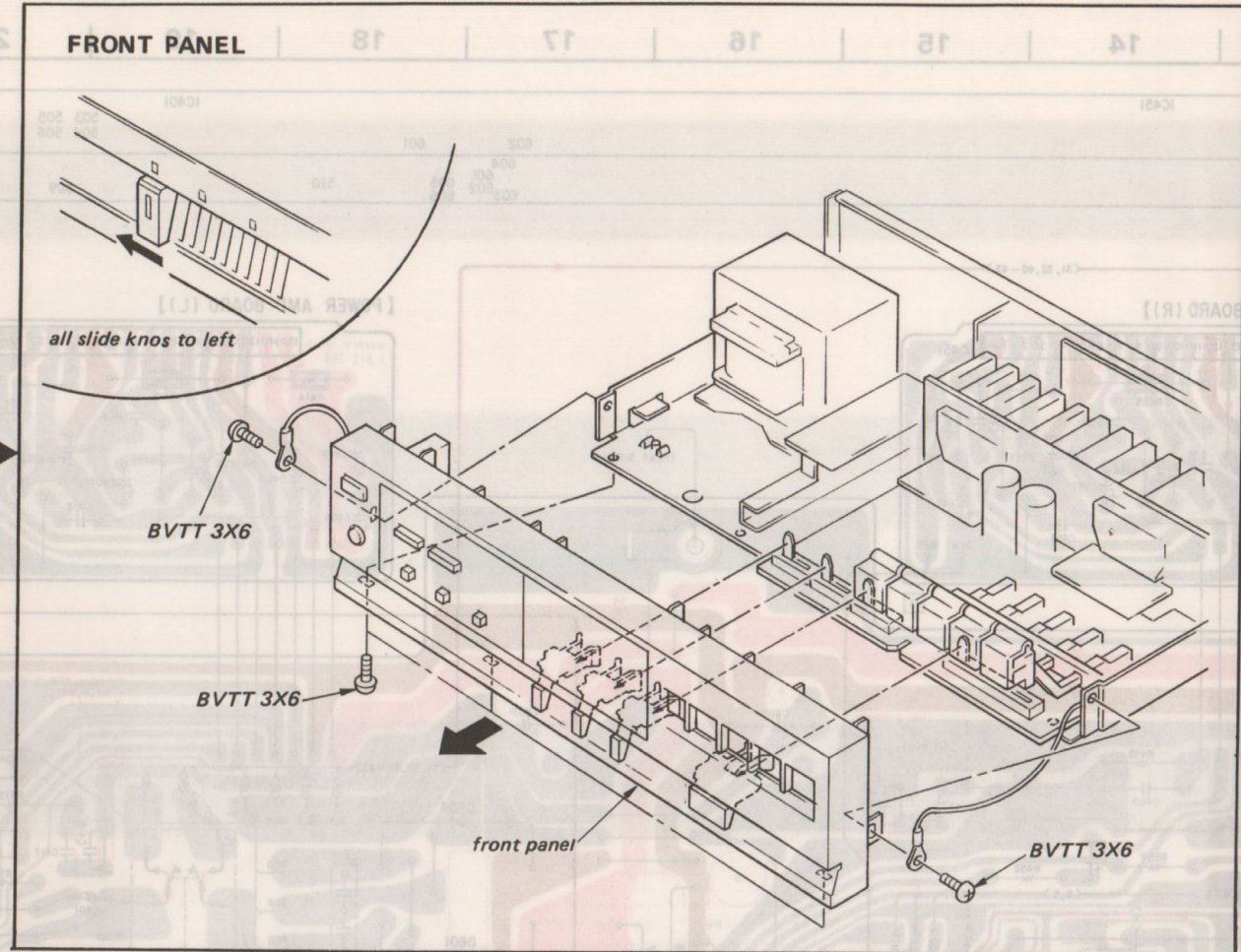
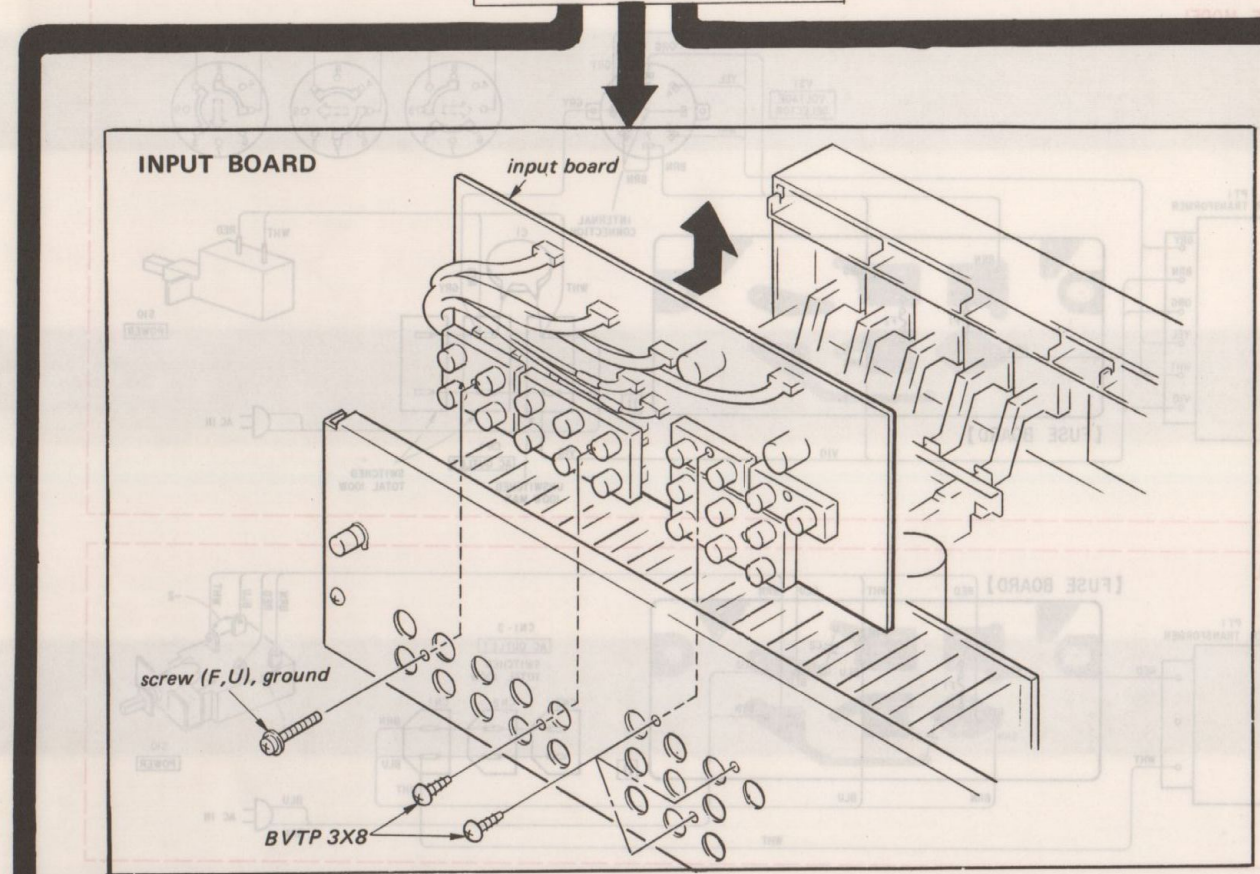

MEMO

SECTION 3
DIAGRAMS

SECTION 3
DIAGRAMS

3-1. MOUNTING DIAGRAM

- : parts extracted from the component side.
- : signal path
- (red) : L-CH signal path
- (blue) : R-CH signal path
- (red) : B+ pattern
- (blue) : B- pattern

● Semiconductor Lead Layouts

2SA988-F 	STK4036X
2SB731 2SD809 	10E-2
2SC2603F DTC144WS 	1SS202-1
CX-770A 	30DL4
LA7220 	GL-9HY4 GL-9NG4
M5218L 	HZ15-3L

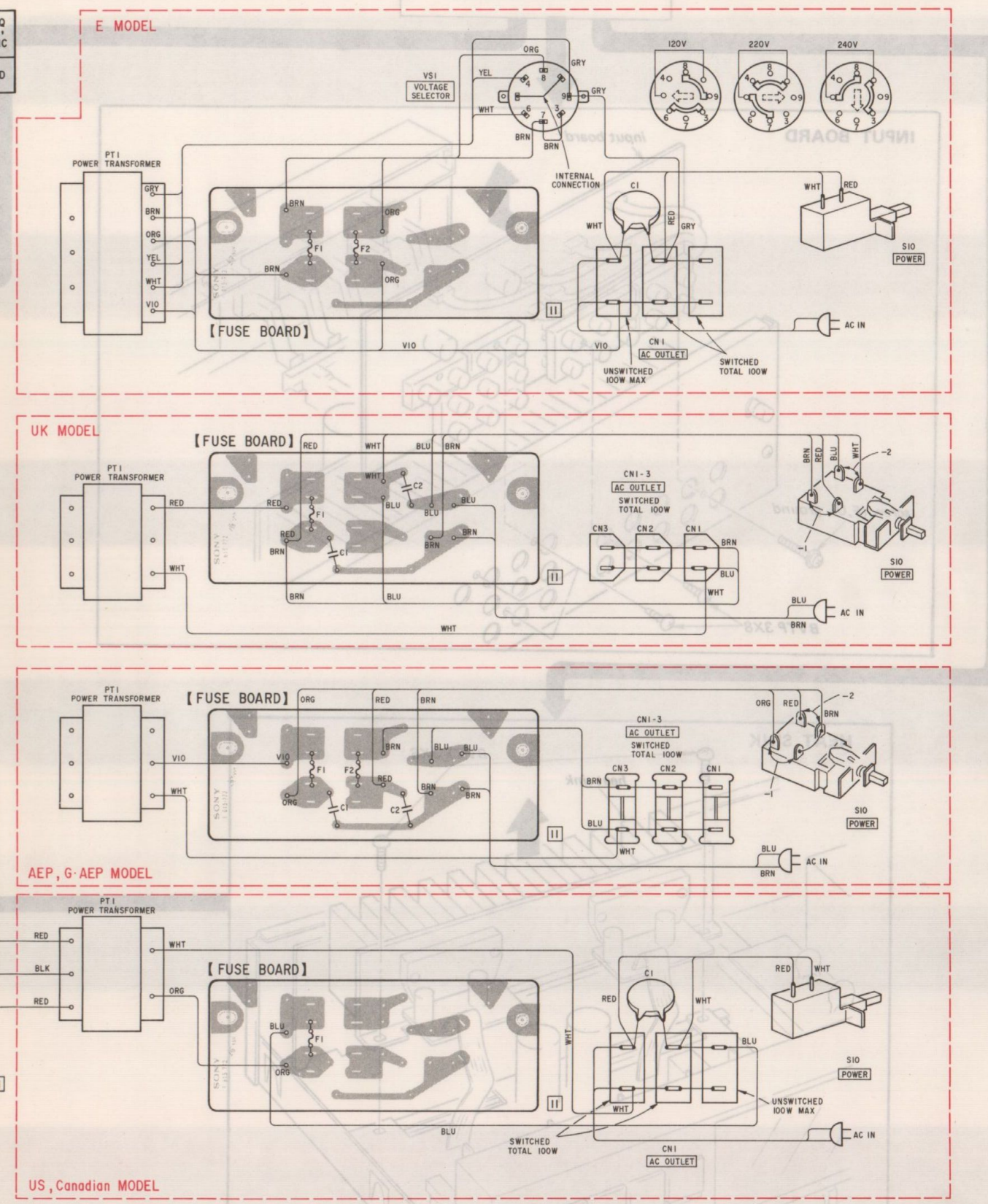
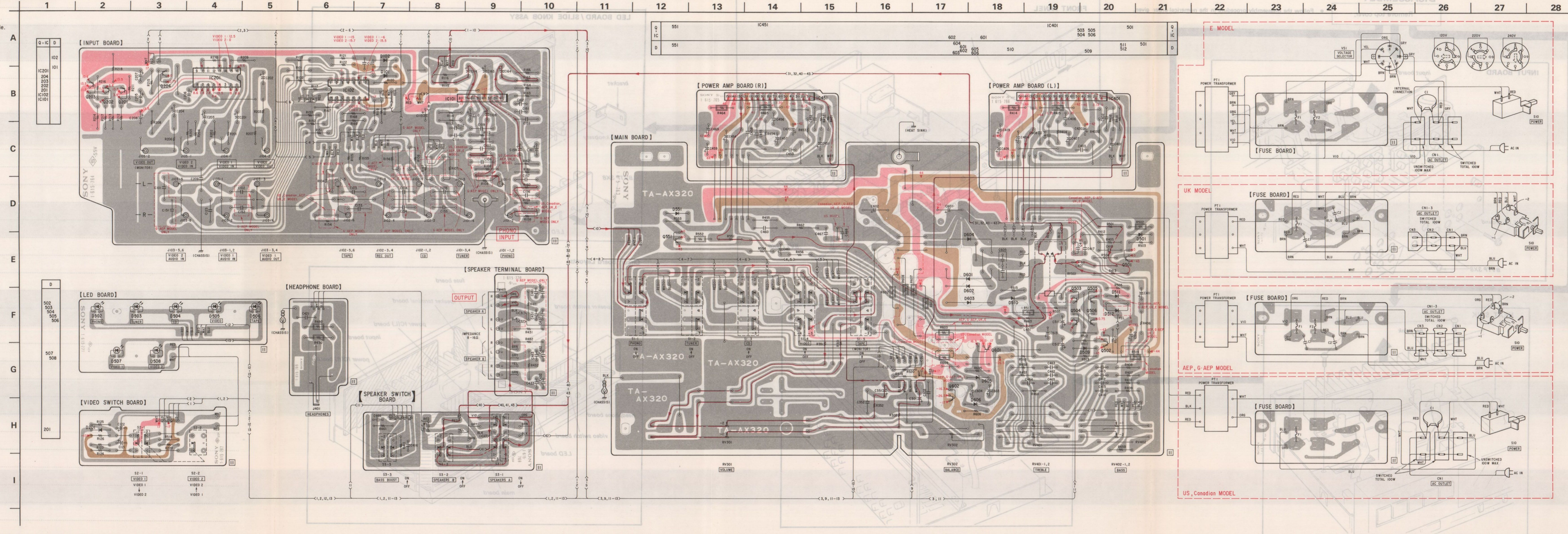

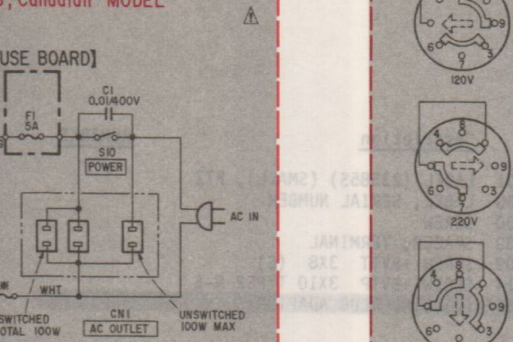
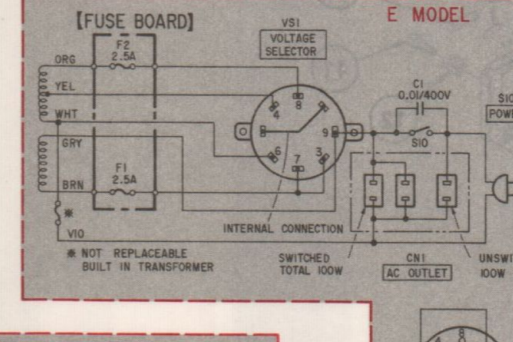
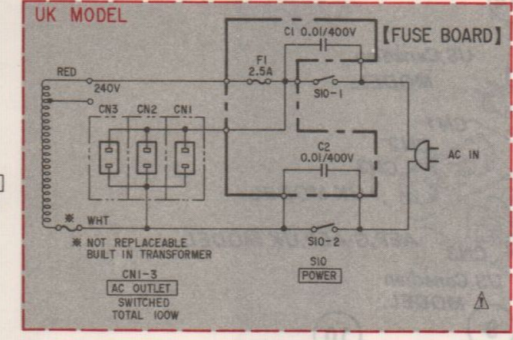
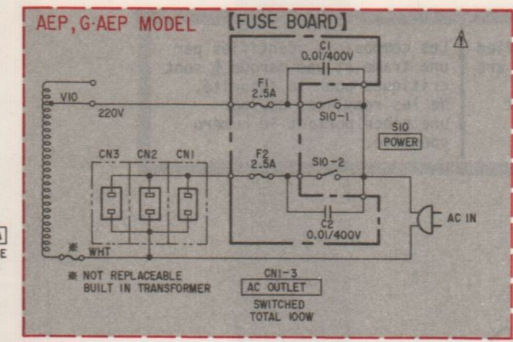
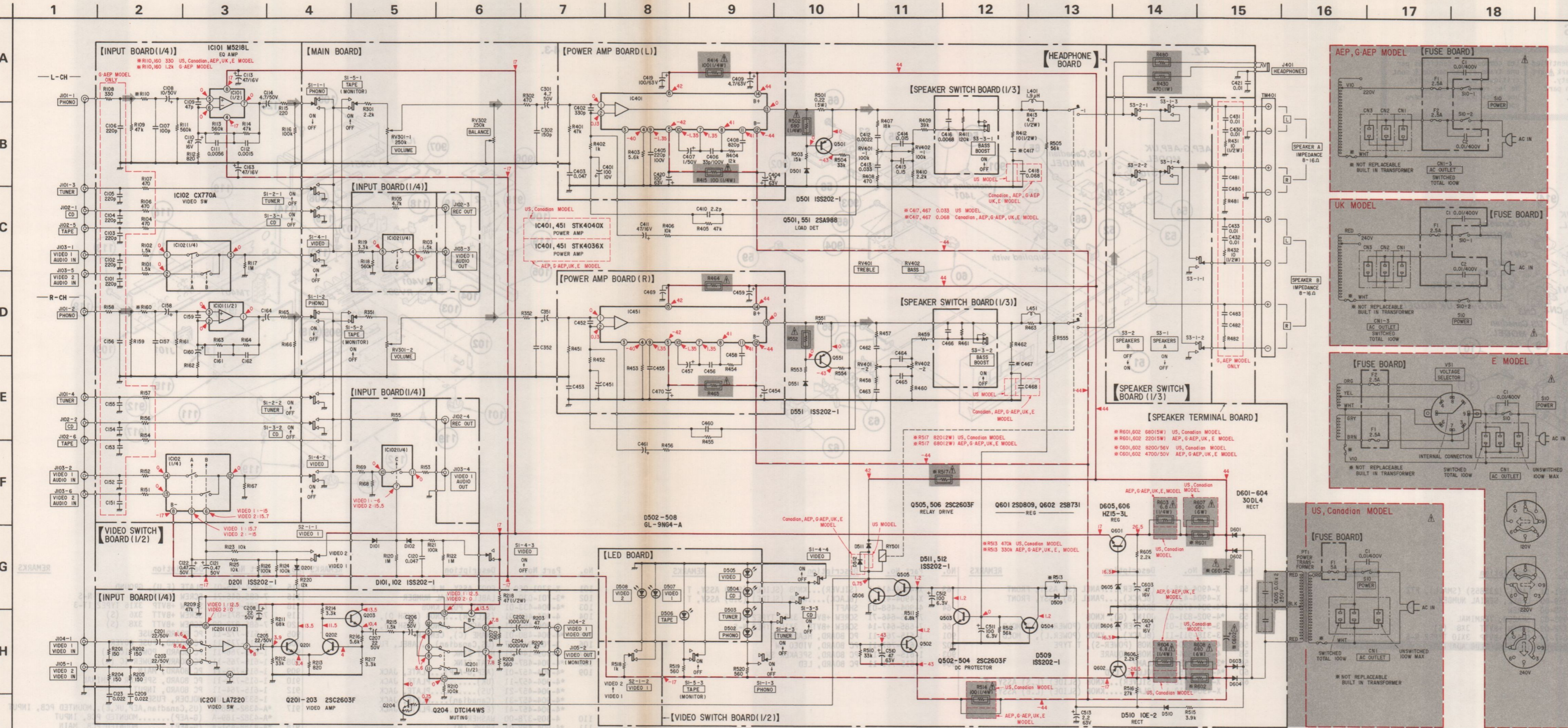

Note:

- All capacitors are in μF unless otherwise noted. pF : μF 50 WV or less are not indicated except for electrolytics and tantalums.
- All resistors are in Ω and $\frac{1}{4}$ W or less unless otherwise specified.
- ◻ : signal path.

Note: The components identified by shading and mark Δ are critical for safety. Replace only with part number specified.

Note: Les composants identifiés par une trame et une marque Δ sont critiques pour la sécurité. Ne les remplacer que par une pièce portant le numéro spécifié.

- Components for right channel have same values as for left channel. Reference numbers are coded from 150, 350, 450, 550.
- ◻ : nonflammable resistor.

Switch

Ref No.	Switch	Position
S1-1	PHONO	ON
S1-2	TUNER	OFF
S1-3	CD	OFF
S1-4	VIDEO	OFF
S1-5	TAPE	OFF
S2-1	VIDEO 1	VIDEO 1
S3-3	SPEAKERS A	ON
S3-2	SPEAKERS B	OFF
S3-3	BASS BOOST	OFF
S10	POWER	OFF

- ◻ : B+ bus.
- ◻ : B- bus.
- Voltagés are dc with respect to ground unless otherwise noted.
- Readings are taken under no-signal conditions with a VOM (50 $\text{k}\Omega/\text{V}$).
- () : [] : < > :
- Voltage variations may be noted due to normal production tolerances.

SECTION 4
EXPLODED VIEWS

NOTE:

- The mechanical parts with no reference number in the exploded views are not supplied.
- Items marked " * " are not stocked since they are seldom required for routine service. Some delay should be anticipated when ordering these items.
- The construction parts of an assembled part are indicated with a collation number in the remark column.

The components identified by shading and mark **A** are critical for safety. Replace only with part number specified.

Les composants identifiés par une trame et une marque **A** sont critiques pour la sécurité. Ne les remplacer que par une pièce portant le numéro spécifié.

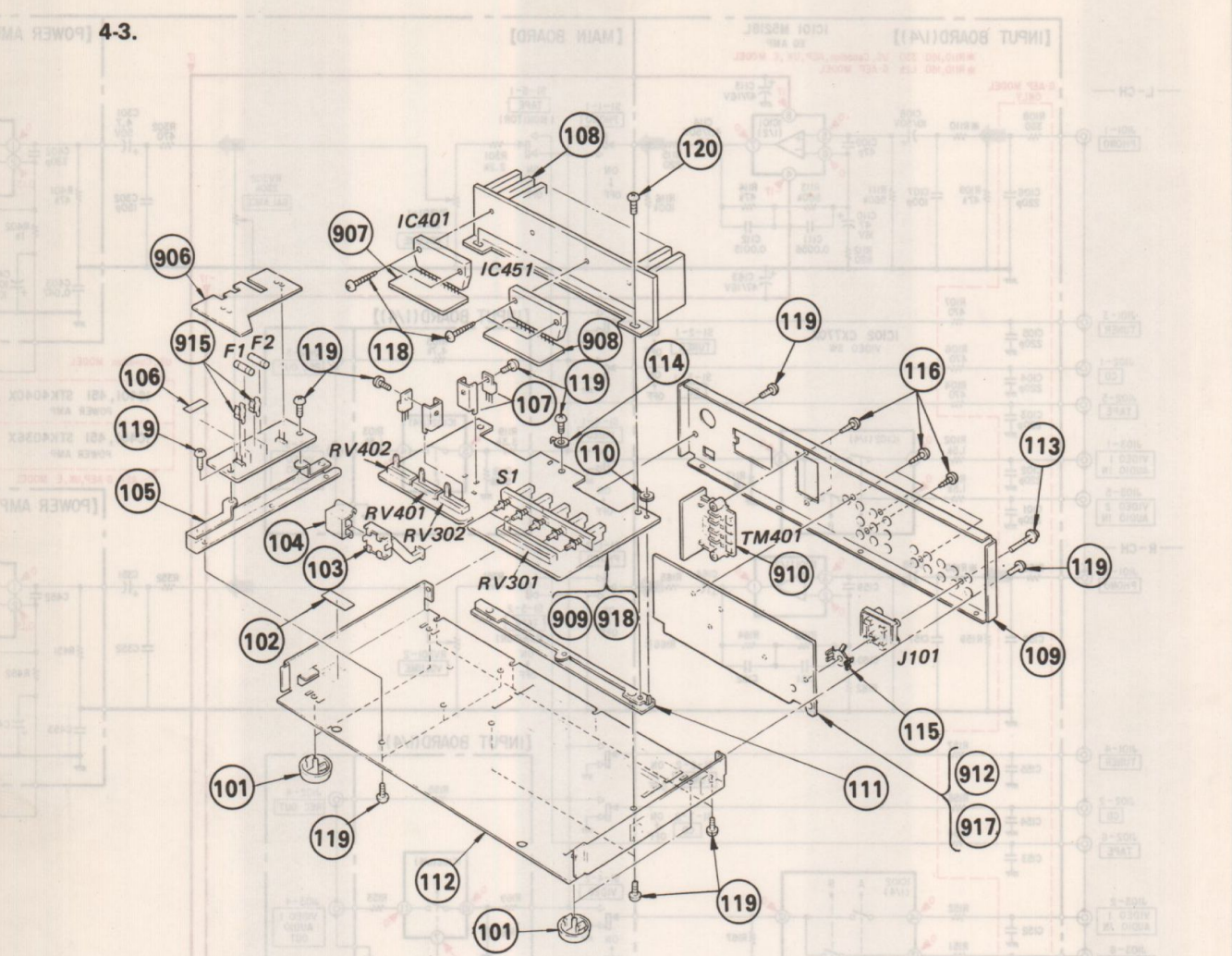
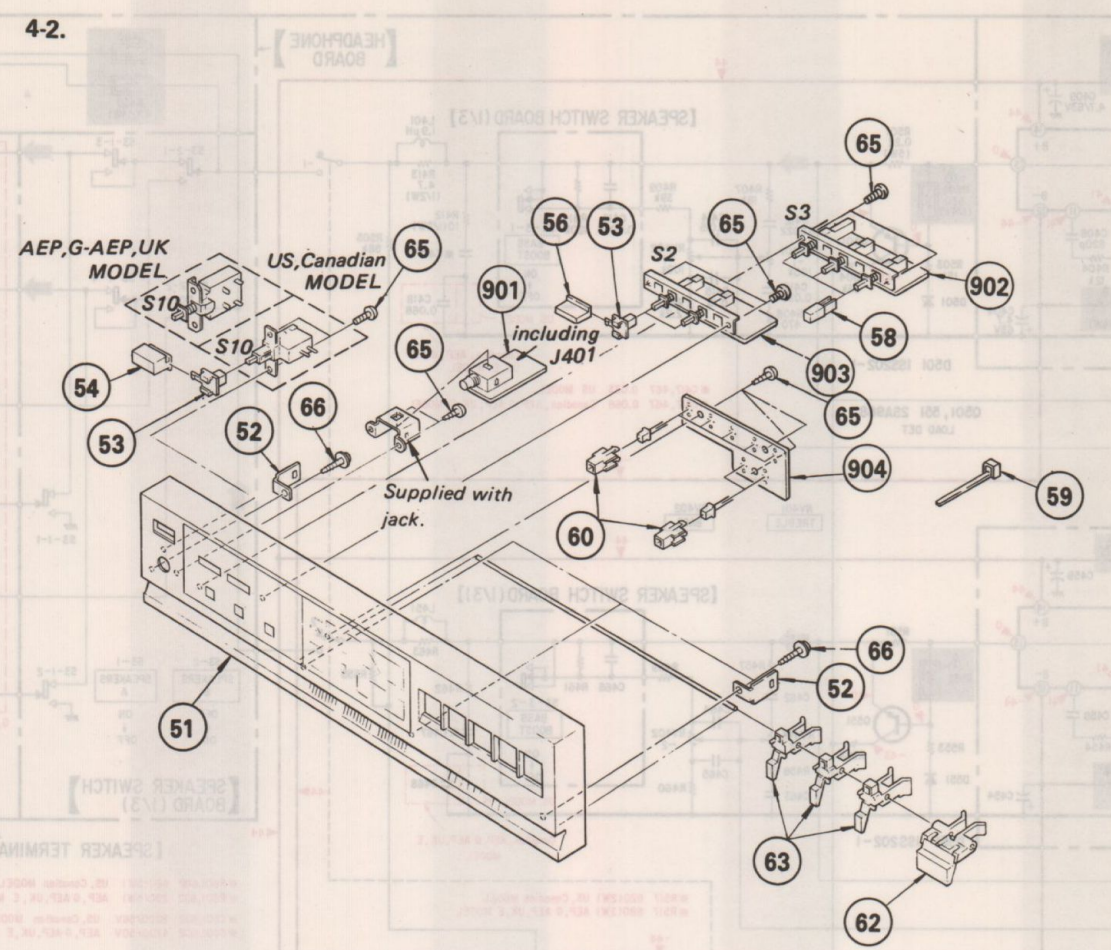
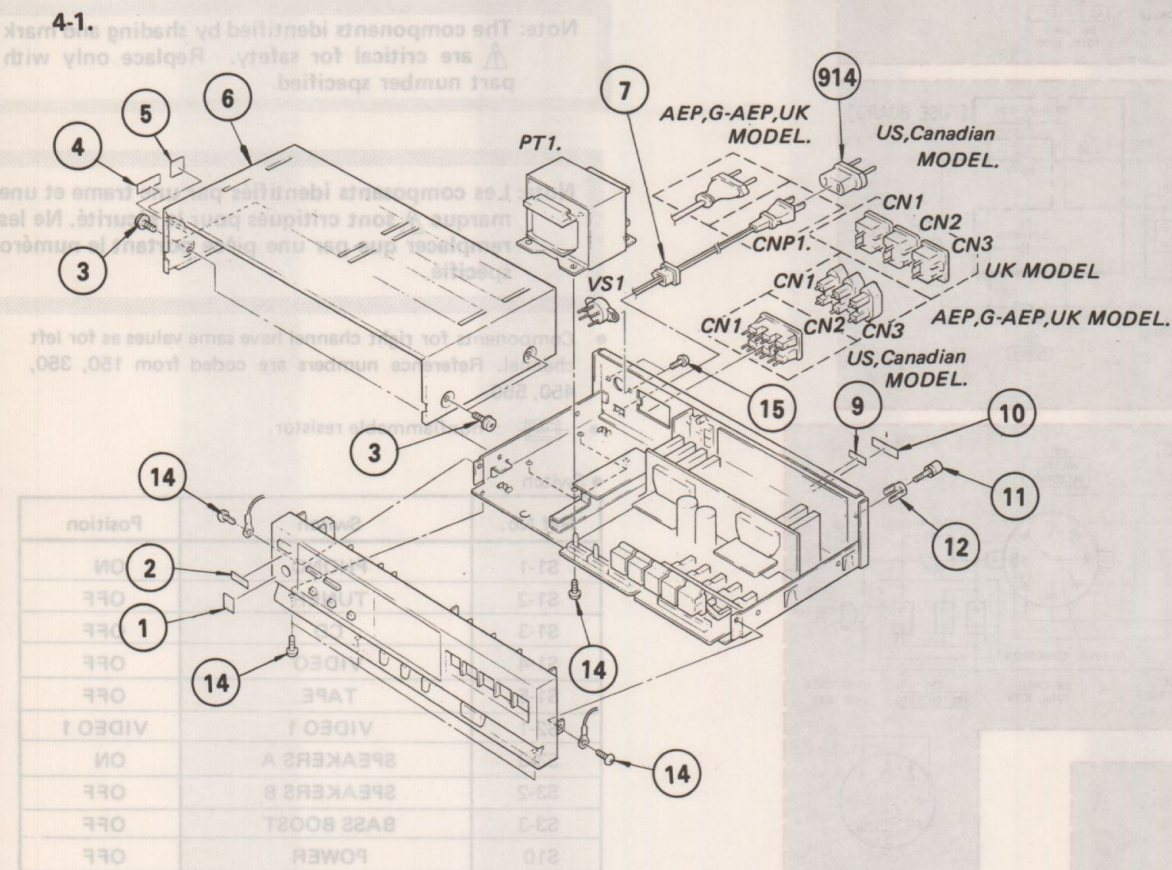

SECTION 6 ELECTRICAL PARTS LIST

NOTE:

- Items marked " * " are not stocked since they are seldom required for routine service. Some delay should be anticipated when ordering these items.
- If there are two or more same circuits in a set such as a stereophonic machine, only typical circuit parts may be indicated and capacitors and resistors in other same circuits may be omitted.

- CAPACITORS:**
MF:μF, PF:μμF.
- RESISTORS**
• All resistors are in ohms.
• F : nonflammable
- COILS**
• MMH : mH, UH : μH
- SEMICONDUCTORS**
In each case, U : μ, for example:
UA...: μA..., UPA...: μPA..., UPC...: μPC,
UPD...: μPD...

The components identified by shading and mark **Δ** are critical for safety. Replace only with part number specified.

Les composants identifiés par une trame et une marque **Δ** sont critiques pour la sécurité. Ne les remplacer que par une pièce portant le numéro spécifié.

ELECTRICAL PARTS

Ref.No.	Part No.	Description
901	1-615-769-11	PC BOARD, HEADPHONE
902	1-615-767-11	PC BOARD, VIDEO SWITCH
903	1-615-768-11	PC BOARD, SPEAKER SWITCH
904	1-615-771-11	PC BOARD, LED
905	1-615-772-11	PC BOARD, FUSE
906	1-615-773-11	PC BOARD, FUSE COVER
907	1-615-766-11	PC BOARD, POWER IC (L)
908	1-615-765-11	PC BOARD, POWER IC (R)
909	1-615-763-11	PC BOARD, MAIN
910	1-615-770-11	PC BOARD, SPEAKER TERMINAL
912	1-615-764-11	PC BOARD, INPUT
914	Δ 1-526-565-00	(E)...AC PLUG ADAPTOR
915	1-533-162-00	HOLDER, FUSE
916	*1-535-115-00	TERMINAL
917	*A-4382-189-A	(G-AEP)...MOUNTED PCB, INPUT
917	*A-4382-188-A	(US,Canadian,AEP,UK,E)..MOUNTED PCB, INPUT
918	*A-4388-451-A	(G-AEP)...MOUNTED PCB, MAIN
918	*A-4388-449-A	(US)...MOUNTED PCB, MAIN
918	*A-4388-450-A	(AEP,UK,E)...MOUNTED PCB, MAIN
918	*A-4388-458-A	(Canadian)...MOUNTED PCB, MAIN
919	*1-535-116-00	TERMINAL
920	*1-535-139-00	BASE POST 19MM (10MM PITCH) 2P
921	*1-562-249-00	SOCKET, CONNECTOR 4P
922	*1-562-250-00	SOCKET, CONNECTOR 5P
923	*1-562-251-00	SOCKET, CONNECTOR 6P
924	*1-562-327-00	SOCKET, CONNECTOR 3P
925	1-535-140-00	(UK)...BASE POST 19MM (10MM PITCH) 3P
C1	Δ 1-161-744-00	CERAMIC 0.01MF 400V
C2	Δ 1-161-744-00	(AEP,G-AEP,UK)...CERAMIC 0.01MF 400V
C101	1-161-315-00	(G-AEP)...CERAMIC 220PF 10% 50V
C102	1-161-315-00	(G-AEP)...CERAMIC 220PF 10% 50V
C103	1-161-315-00	(G-AEP)...CERAMIC 220PF 10% 50V
C104	1-161-315-00	(G-AEP)...CERAMIC 220PF 10% 50V
C105	1-161-315-00	(G-AEP)...CERAMIC 220PF 10% 50V
C106	1-161-315-00	(G-AEP)...CERAMIC 220PF 10% 50V
C107	1-161-271-00	CERAMIC 100PF 5% 50V
C108	1-123-356-00	ELECT 10MF 20% 50V
C109	1-161-267-00	CERAMIC 47PF 5% 50V
C110	1-123-332-00	ELECT 47MF 20% 16V
C111	1-110-204-00	MYLAR 0.0056MF 5% 50V
C112	1-110-197-00	MYLAR 0.0015MF 5% 50V
C113	1-123-332-00	ELECT 47MF 20% 16V
C114	1-123-369-00	ELECT 4.7MF 20% 50V
C120	1-136-161-00	FILM 0.047MF 5% 50V
C121	1-123-379-00	ELECT 0.47MF 20% 50V

ELECTRICAL PARTS

Ref.No.	Part No.	Description
C122	1-123-379-00	ELECT 0.47MF 20% 50V
C123	1-161-494-00	CERAMIC 0.022MF 30% 25V
C201	1-123-357-00	ELECT 22MF 20% 50V
C202	1-123-311-00	ELECT 1000MF 20% 10V
C203	1-123-357-00	ELECT 22MF 20% 50V
C204	1-123-311-00	ELECT 1000MF 20% 10V
C205	1-123-357-00	ELECT 22MF 20% 50V
C206	1-123-357-00	ELECT 22MF 20% 50V
C207	1-123-357-00	ELECT 22MF 20% 50V
C208	1-123-357-00	ELECT 22MF 20% 50V
C209	1-161-494-00	CERAMIC 0.022MF 30% 25V
C301	1-123-369-00	ELECT 4.7MF 20% 50V
C302	1-161-313-00	CERAMIC 150PF 10% 50V
C401	1-123-307-00	ELECT 100MF 20% 10V
C402	1-161-317-00	CERAMIC 330PF 10% 50V
C403	1-136-161-00	FILM 0.047MF 5% 50V
C404	1-123-369-00	ELECT 4.7MF 20% 63V
C405	1-107-308-00	MICA 220PF 5% 100V
C406	1-107-288-00	MICA 33PF 5% 100V
C407	1-123-380-00	ELECT 1MF 20% 50V
C408	1-161-322-00	CERAMIC 820PF 10% 50V
C409	1-123-369-00	ELECT 4.7MF 20% 63V
C410	1-161-251-00	CERAMIC 2.2PF 10% 50V
C411	1-123-332-00	ELECT 47MF 20% 16V
C412	1-110-199-00	MYLAR 0.0022MF 5% 50V
C413	1-136-159-00	FILM 0.033MF 5% 50V
C414	1-136-155-00	FILM 0.015MF 5% 50V
C415	1-136-167-00	FILM 0.15MF 5% 50V
C416	1-110-205-00	MYLAR 0.0068MF 5% 50V
C417	1-136-163-00	(Canadian,AEP,G-AEP,UK,E)... FILM 0.068MF 5% 50V
C417	1-136-159-00	(US)...FILM 0.033MF 5% 50V
C418	1-136-163-00	(Canadian,AEP,G-AEP,UK,E)... FILM 0.068MF 5% 50V
C419	1-123-374-00	ELECT 100MF 20% 63V
C420	1-123-374-00	ELECT 100MF 20% 63V
C421	1-161-379-00	CERAMIC 0.01MF 20% 25V
C430	1-136-153-00	(G-AEP)...FILM 0.01MF 5% 50V
C431	1-136-153-00	(G-AEP)...FILM 0.01MF 5% 50V
C432	1-136-153-00	(G-AEP)...FILM 0.01MF 5% 50V
C433	1-136-153-00	(G-AEP)...FILM 0.01MF 5% 50V
C510	1-123-373-00	ELECT 47MF 20% 63V
C511	1-123-307-00	ELECT 100MF 20% 6.3V
C512	1-123-307-00	ELECT 100MF 20% 6.3V
C513	1-123-381-00	ELECT 2.2MF 20% 63V

SECTION 8 ELECTRICAL PARTS LIST

ELECTRICAL PARTS

Table with columns: Ref.No., Part No., Description. Includes parts like C601, C602, C603, CN1, CN2, CN3, CNP1, D101, D102, D201, D501, D502, D503, D504, D505, D506, D507, D508, D509, D510, D511, D512, D551, D601, D602, D603, D604, D605, D606, F1, F2.

ELECTRICAL PARTS

Table with columns: Ref.No., Part No., Description. Includes parts like IC101, IC102, IC201, IC401, IC451, J101, J102, J103, J104, J105, J401, L401, L451, PT1, PT2, PT3, Q201, Q202, Q203, Q204, Q501, Q502, Q503, Q504, Q505, Q506, Q551, Q601, Q602, R101, R102, R103, R104, R105, R106, R107, R108, R109, R110, R111, R112, R113.

ELECTRICAL PARTS

Table with columns: Ref.No., Part No., Description. Includes parts like R114, R115, R116, R117, R118, R119, R120, R121, R122, R123, R124, R125, R126, R201, R202, R203, R204, R205, R206, R207, R208, R209, R210, R211, R212, R213, R214, R215, R216, R217, R218, R220, R301, R302, R401, R402, R403, R404, R405, R406, R407, R408, R409, R410, R411, R412.

ELECTRICAL PARTS

Table with columns: Ref.No., Part No., Description. Includes parts like R413, R414, R415, R430, R431, R432, R464, R465, R480, R501, R502, R503, R504, R505, R510, R511, R512, R513, R514, R515, R516, R517, R518, R519, R520, R552, R601, R602, R603, R604, R605, R606, R607, R608, RV301, RV302, RV401, RV402, RY501, S1, S2, S3.

The components identified by shading and mark A are critical for safety. Replace only with part number specified.

The components identified by shading and mark A are critical for safety. Replace only with part number specified.

ELECTRICAL PARTS

ELECTRICAL PARTS

Ref.No.	Part No.	Description
S10	▲ 1-553-318-41	(US,Canadian,E)...SWITCH, PUSH (AC POWER)(1 KEY)
S10	▲ 1-554-685-11	(AEP,G-AEP,UK)...SWITCH, PUSH (AC POWER)(1 KEY)
TM401	1-536-706-00	TERMINAL BOARD (SP)
VS1	▲ 1-526-576-51	(E)...SELECTOR, POWER VOLTAGE

ACCESSORY & PACKING MATERIAL

Part No.	Description
3-701-630-00	BAG, POLYETHYLENE
3-760-467-11	(US,Canadian,AEP,UK,E) ...MANUAL, INSTRUCTION
3-760-467-41	(AEP,G-AEP)...MANUAL, INSTRUCTION
4-876-352-00	SHEET, PROTECTION
4-904-442-01	CUSHION (LEFT), LOWER
4-904-443-01	CUSHION (RIGHT), LOWER
4-904-444-01	CUSHION (LEFT), UPPER
4-904-445-01	CUSHION (RIGHT), UPPER
4-904-484-01	INDIVIDUAL CARTON

Ref.No.	Part No.	Description
R114	1-547-171-00	CARBON
R115	1-547-172-00	CARBON
R116	1-547-173-00	CARBON
R117	1-548-842-00	CARBON
R118	1-548-843-00	CARBON
R119	1-547-143-00	CARBON
R120	1-548-842-00	CARBON
R121	1-547-173-00	CARBON
R122	1-548-842-00	CARBON
R123	1-547-152-00	CARBON
R124	1-547-173-00	CARBON
R125	1-547-152-00	CARBON
R126	1-547-179-00	CARBON
R201	1-547-171-00	CARBON
R202	1-547-171-00	CARBON
R203	1-547-688-11	CARBON
R204	1-547-171-00	CARBON
R205	1-547-171-00	CARBON
R206	1-547-688-11	CARBON
R207	1-547-152-00	CARBON
R208	1-547-152-00	CARBON
R209	1-547-171-00	CARBON
R210	1-547-179-00	CARBON
R211	1-547-173-00	CARBON
R212	1-547-143-00	CARBON
R213	1-547-152-00	CARBON
R214	1-547-143-00	CARBON
R215	1-547-132-00	CARBON
R216	1-547-143-00	CARBON
R217	1-547-143-00	CARBON
R218	1-544-841-00	CARBON

The components identified by shading and mark ▲ are critical for safety. Replace only with part number specified.

Les composants identifiés par une trame et une marque ▲ sont critiques pour la sécurité. Ne les remplacer que par une pièce portant le numéro spécifié.

The components identified by shading and mark ▲ are critical for safety. Replace only with part number specified.

Les composants identifiés par une trame et une marque ▲ sont critiques pour la sécurité. Ne les remplacer que par une pièce portant le numéro spécifié.