

TA-A67/D609

SERVICE MANUAL

AEP Model

TA-D609

E Model

Australian Model

TA-A67



This set is the Amplifier section in LBT-A67CD/A67CDM/D609CD.

This photo is TA-D609.

SPECIFICATIONS

TA-A67

Continuous RMS power output
70 W + 70 W
(6 ohms, at 1 kHz, 5% THD)

Peak music power output 850W (4 speakers driven)

Input	Jack type	Sensitivity	Impedance
VIDEO 1/MD	Phono	245 mV	47 kohms
VIDEO 2	Phono	245 mV	47 kohms
PHONO (MM)	Phono	3.3 mV	47 kohms
MIC	Phone	1 mV	10 kohms

Audio output	Jack type	Voltage	Impedance
VIDEO 1/MD	Phono	200 mV	2 kohms
SURROUND SPEAKER	Phono	Accepts speakers of 16 ohms	
HEADPHONES	Stereophone	Accepts headphones of 8 ohms or more	

Video output (phono jacks)
VIDEO 1/MD 1 Vp-p, 75 ohm unbalanced, sync negative

MONITOR 1 Vp-p, 75 ohm unbalanced, sync negative

Frequency response 15 Hz to 50 kHz ± 0 dB

Power requirements
TYPE I
120V/220V/240V AC, adjustable with the voltage selector, 50/60Hz

TYPE II
120V/220V/230—240V AC, adjustable with the voltage selector, 50/60Hz

Power consumption 190W

Weight Approx. 6.6 kg (14 lbs 9 oz)

Dimensions Approx. 355 x 135 x 330 mm
(14 x 5 1/4 x 12 7/8 inches)
(w/h/d, including projections)

Design and specifications are subject to change without notice.

TA-D609

Continuous RMS power output
70 W + 70 W
(6 ohms, at 1 kHz, 5% THD)

Music power output 60 W + 60 W (6 ohms, DIN, 1 kHz)
110 W + 110 W
(6 ohms, at 1 kHz, 10% THD)

Input	Jack type	Sensitivity	Impedance
VIDEO 1/MD	Phono	245 mV	47 kohms
VIDEO 2	Phono	245 mV	47 kohms
PHONO (MM)	Phono	3.3 mV	47 kohms
MIC	Phone	1 mV	10 kohms

Audio output	Jack type	Voltage	Impedance
VIDEO 1/MD	Phono	200 mV	2 kohms
SURROUND SPEAKER	Phono	Accepts speakers of 16 ohms	
HEADPHONES	Stereophone	Accepts headphones of 8 ohms or more	

Video output (phono jacks)
VIDEO 1/MD 1 Vp-p, 75 ohm unbalanced, sync negative

MONITOR 1 Vp-p, 75 ohm unbalanced, sync negative

Frequency response 15 Hz to 50 kHz ± 0 dB

Power requirements 220 - 230 V AC, 50/60 Hz

Power consumption 160 W

Weight Approx. 6.6 kg (14 lbs 9 oz)

Dimensions Approx. 355 x 135 x 330 mm
(14 x 5 1/4 x 12 7/8 inches)
(w/h/d, including projections)

Design and specifications are subject to change without notice.

INTEGRATED STEREO AMPLIFIER
SONY®

MODEL IDENTIFICATION

—Specification Label—

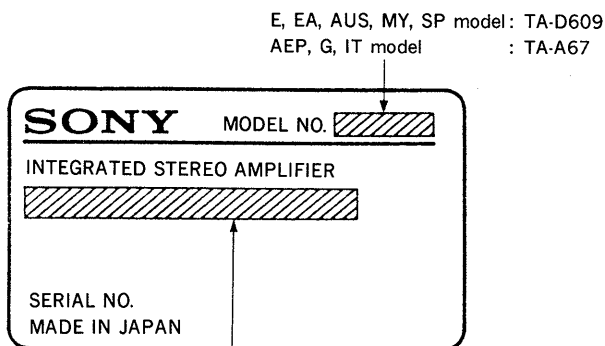

AEP, IT model : AC: 220V—230V~50/60Hz 160W
 G model : SYSTEM LBT-D609
 AC: 220V—230V~50/60Hz 160W
 E, EA, AUS model: AC: 120V/220V/240V~50/60Hz 190W
 MY, SP model : AC: 120V/220V/230V—240V~50/60Hz 190W

• Abbreviations

EA : Saudi Arabia model
 AUS: Australian model
 MY : Malaysia model
 SP : Singapore model
 G : German model
 IT : Italian model

SAFETY-RELATED COMPONENT WARNING!!



COMPONENTS IDENTIFIED BY MARK  OR DOTTED LINE WITH MARK  ON THE SCHEMATIC DIAGRAMS AND IN THE PARTS LIST ARE CRITICAL TO SAFE OPERATION. REPLACE THESE COMPONENTS WITH SONY PARTS WHOSE PART NUMBERS APPEAR AS SHOWN IN THIS MANUAL OR IN SUPPLEMENTS PUBLISHED BY SONY.

TABLE OF CONTENTS

<u>Section</u>	<u>Title</u>	<u>Page</u>
1. GENERAL		
1-1.	Location of Controls	2
2. SERVICE NOTE		
2-1.	Removal of Joint	3
3. DIAGRAMS		
3-1.	Circuit Boards Location	4
3-2.	Semiconductor Lead Layouts	5
3-3.	Printed Wiring Boards —Main Section—	6
3-4.	Schematic Diagram —Main Section—	9
3-5.	Schematic Diagram —Panel Section—	14
3-6.	Printed Wiring Boards —Panel Section—	17
4. EXPLODED VIEWS		
4-1.	Front Panel Section	22
4-2.	Chassis Section	23
5. ELECTRICAL PARTS LIST		
	24

SECTION 1 GENERAL

1-1. LOCATION OF CONTROLS

This section is extracted from instruction manual.

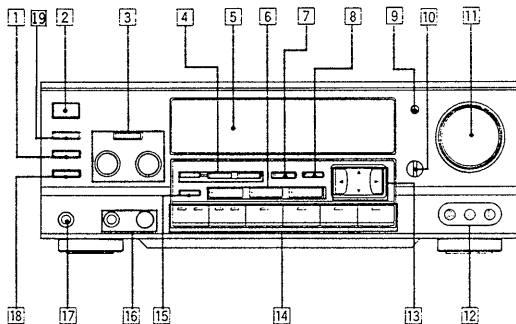

- 1] EFFECT button and indicator
- 2] POWER switch
- 3] DYNAMIC BASS SYSTEM controls (ON/OFF, FREQUENCY, LEVEL)
- 4] DIGITAL SURROUND controls (ON/OFF, MODE, CONTROL and indicator)
- 5] Display window
- 6] CURSOR MODE buttons (EQUALIZER, SELECT 10, PERSONAL FILE and indicators)
- 7] CD DIRECT button and indicator
- 8] MEMORY button and indicator
- 9] DISPLAY button
- 10] BALANCE control
- 11] VOLUME control
- 12] VIDEO 2 INPUT jacks
- 13] CURSOR CONTROL section
- 14] Function selectors and indicators
- 15] EQ FLAT button
- 16] MIC (microphone) jack and MIC LEVEL control
- 17] HEADPHONES jack
- 18] P. FUNCTION button and indicator
- 19] KARAOKE PON button and indicator

SECTION 2 SERVICE NOTE

Note : Follow the disassembly procedure in the numerical order given.

2-1. REMOVAL OF JOINT

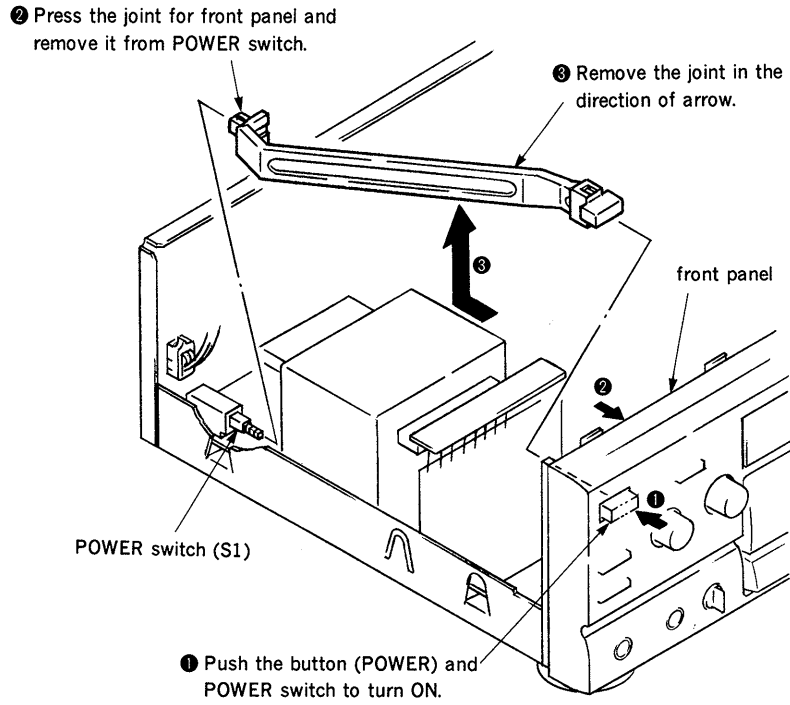

SECTION 3 DIAGRAMS

3-1. CIRCUIT BOARDS LOCATION

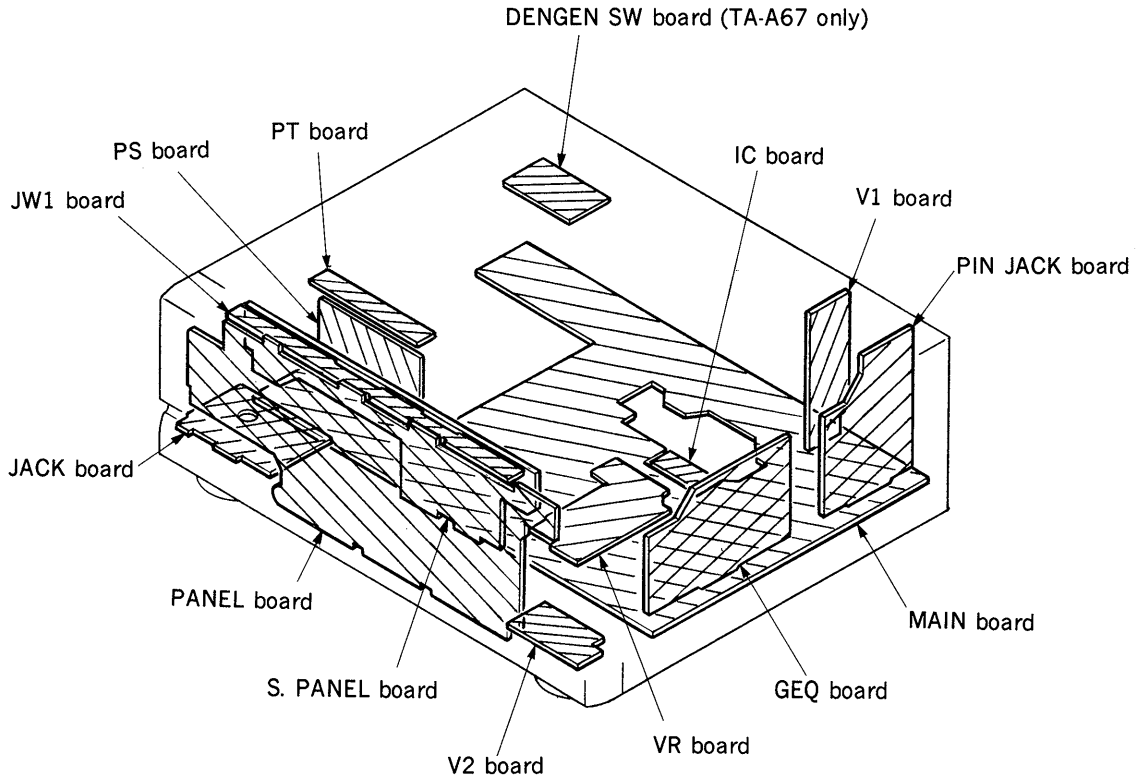

3-2. SEMICONDUCTOR LEAD LAYOUTS

LB1639
M5218AP

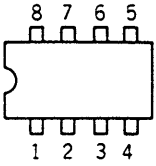

(TOP VIEW)

LC4966
MC14066BCP

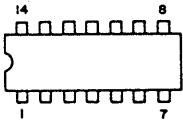

(TOPVIEW)

LC7522K

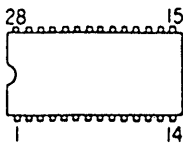

(TOP VIEW)

MC14052BCP
MC14053BCP
TC4094BP
XR1091DCP

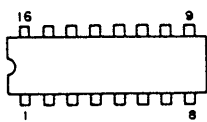

(TOP VIEW)

MM1031XS

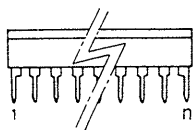

M5F79M07

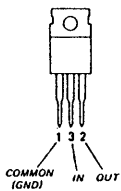

M51943BSL

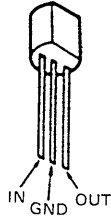

M5218AL
M5218AL-22
 μ PC1237HA

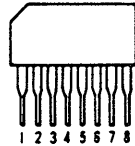

M5289P

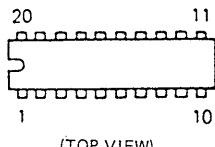

(TOP VIEW)

M65831P

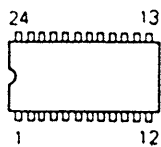

(TOP VIEW)

STK-401-080
STK-401-090

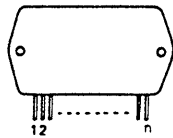

TA7807S

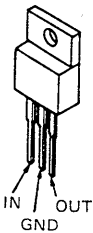

μ PD78042GF-018-3B9

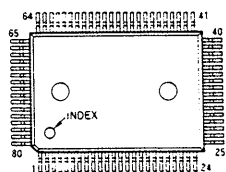

(TOP VIEW)

DTA114ES
DTC114ES
DTC124ES
2SC2603-EF
2SC3622A-LK

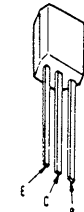

DTA124ES
letter side



2SA1175-FEK
2SC1841-PAFAEA

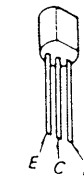

2SB1094-LK

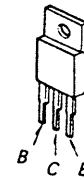

2SK246-GR

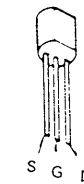

HZS30-2L
HZS7C2L
UZ-4.7BSA
UZL-6L3
UZL-6M2
UZL-7L3
11ES2

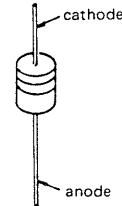

UZP-6.2B
1N4148M
1S1585
10E2N

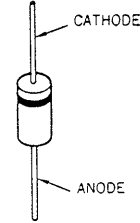

RBV-602-01

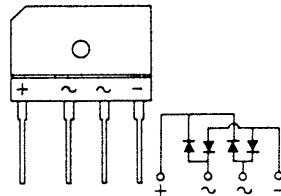

SEL3210S-CD
SEL3510C-CD

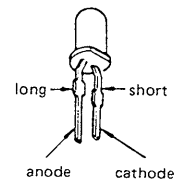

SML1860A



● Semiconductor Location

Ref. No.	Location	Ref. No.	Location
D201	C-7	IC301	G-7
D202	C-7	IC302	E-7
D301	J-8	IC303	H-8
D302	J-8	IC304	H-7
D303	J-8	IC306	J-7
D304	F-7	IC401	C-7
D305	F-8	IC421	J-22
D501	I-3	IC501	F-2
D502	I-4	IC502	H-3
D701	F-13	IC503	J-4
D702	F-12	IC551	G-4
D703	H-13	IC701	F-10
D704	H-12	IC702	G-12
D705	F-12	IC801	I-10
D801	G-17	IC802	J-10
D802	I-11		
D803	I-11	Q201	B-22
D804	I-11	Q202	B-22
D805	I-11	Q203	B-22
D806	H-16	Q204	B-22
D807	H-15	Q205	C-22
D808	H-15	Q250	J-9
D809	H-15	Q251	J-8
D811	H-16	Q252	J-9
D812	H-16	Q301	F-8
D813	I-10	Q302	F-8
D814	J-10	Q303	G-8
D820	G-18	Q304	G-8
D821	G-18	Q305	H-7
D822	J-17	Q504	J-3
D823	K-17	Q510	I-4
		Q554	I-3
IC101	C-2	Q701	F-12
IC102	C-3	Q702	F-12
IC103	C-8	Q751	F-11
IC201	B-20	Q801	J-17
IC250	F-8		

Note:
 ● ○ : parts extracted from the component side.
 ● ■ : Pattern on the side which is seen.
 ● Abbreviations
 G : German model
 IT : Italian model

3-3. PRINTED WIRING BOARDS —MAIN SECTION— ● Refer to page 5 for Semiconductor Lead Layouts.

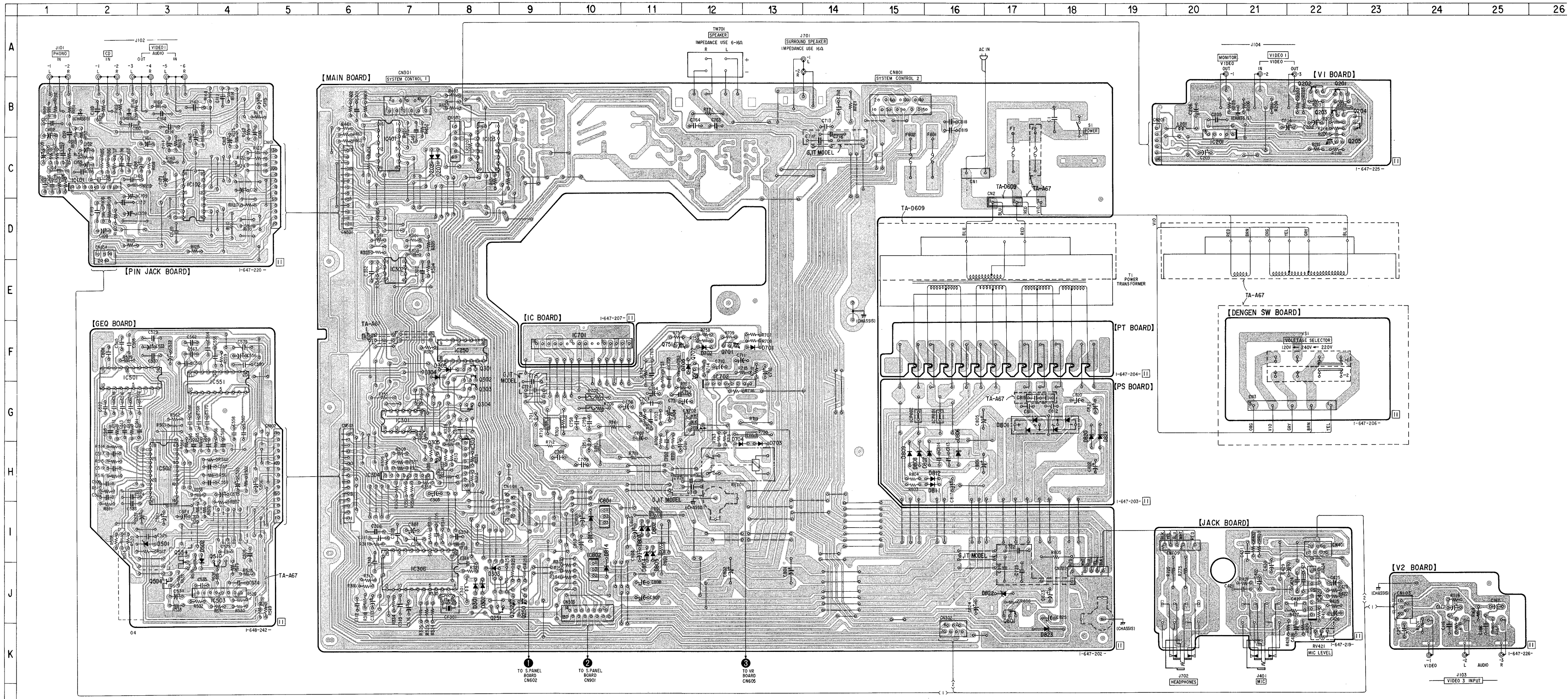

3-4. SCHEMATIC DIAGRAM —MAIN SECTION— Refer to page 20 for IC Block Diagrams.

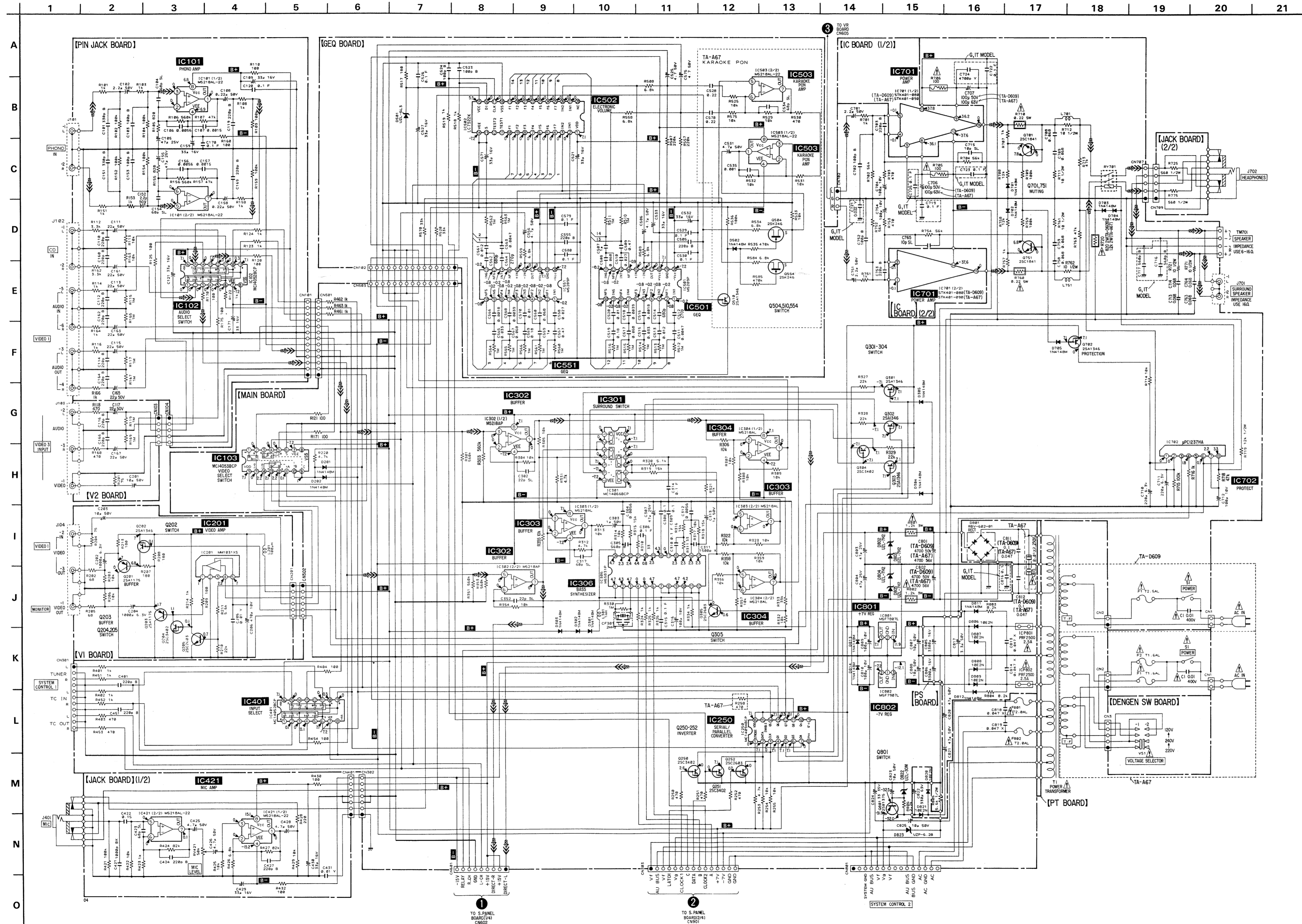

Note:

- All capacitors are in μF unless otherwise noted. pF : μF 50V or less are not indicated except for electrolytics and tantalums.
- All resistors are in Ω and $\frac{1}{2}\text{W}$ or less unless otherwise specified.
- Δ : internal component.
- \square : nonflammable resistor.
- \square : fusible resistor.

Note: The components identified by mark Δ or dotted line with mark Δ are critical for safety. Replace only with part number specified.

- $B+$: B+ Line
- $B-$: B- Line
- Voltage is dc with respect to ground under no-signal conditions. no mark: PHONO
- Voltages are taken with a VOM (Input Impedance $10\text{M}\Omega$). Voltage variations may be noted due to normal production tolerances.
- Signal path.
- \Rightarrow : PHONO
- Abbreviations
- G: German model
- IT: Italian model

3-5. SCHEMATIC DIAGRAM —PANEL SECTION— • Refer to page 20 for IC Block Diagrams.

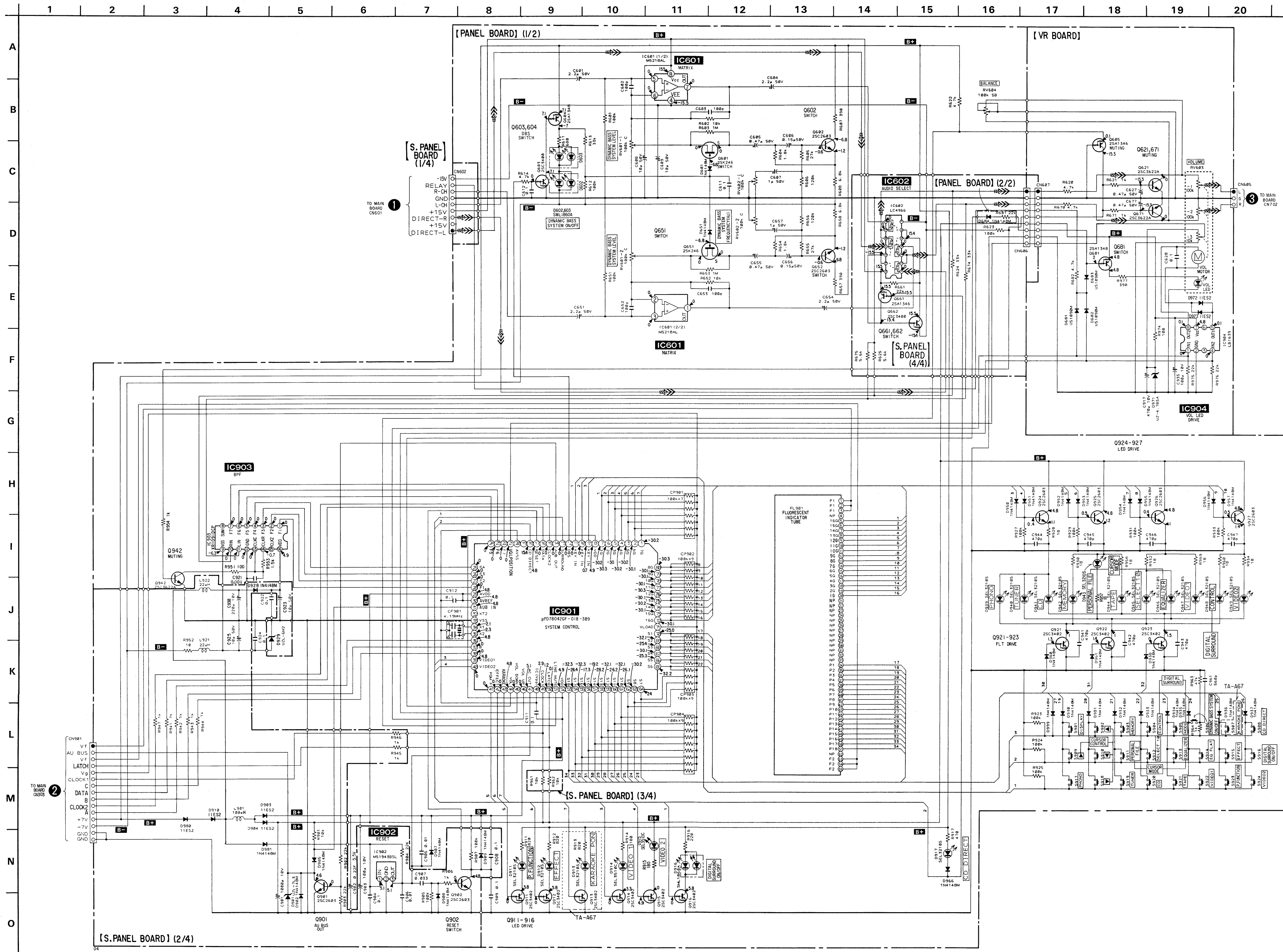

- Note:
- All capacitors are in μF unless otherwise noted. pF: μF 50V or less are not indicated except for electrolytics and tantalums.
 - All resistors are in Ω and $\frac{1}{2}W$ or less unless otherwise specified.
 - Δ : internal component.
 - \square : B+ Line
 - \blacksquare : B- Line
 - Voltage is dc with respect to ground under no-signal conditions. no mark : PHONO
 - Voltages are taken with a VOM (Input Impedance $10M\Omega$). Voltage variations may be noted due to normal production tolerances.
 - Signal path.
 - \Rightarrow : PHONO

3-6. PRINTED WIRING BOARDS —PANEL SECTION— • Refer to page 5 for Semiconductor Lead Layouts.

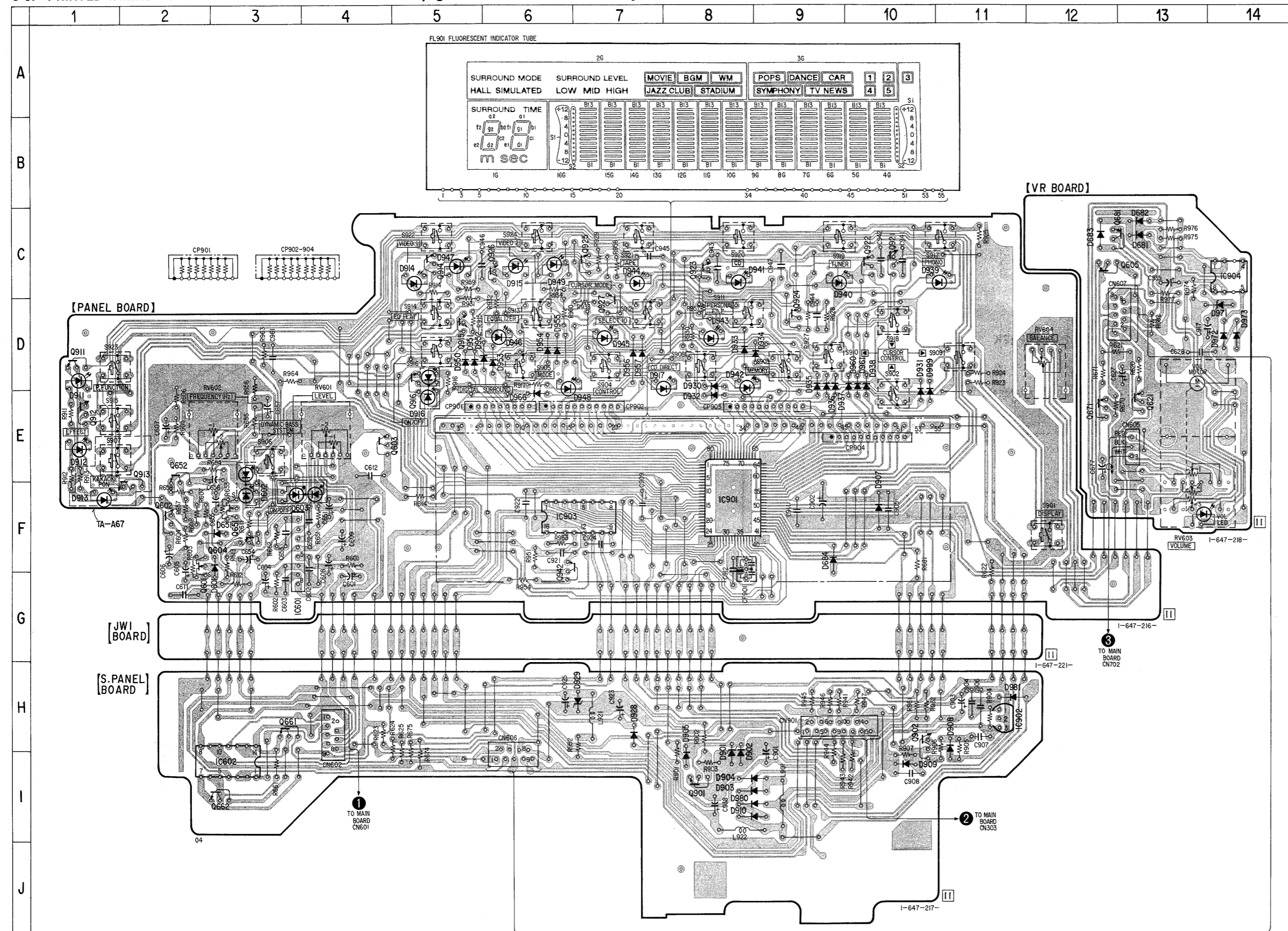

• Semiconductor Location

Ref. No.	Location	Ref. No.	Location
D601	G-3	D954	D-6
D602	F-3	D955	D-6
D603	F-3	D956	D-7
D651	F-3	D957	D-7
D681	C-13	D960	D-10
D682	C-13	D961	D-10
D683	C-12	D966	E-6
D684	F-9	D971	D-14
D901	I-8	D972	D-14
D902	I-8	D973	D-14
D903	I-8	D980	I-8
D904	I-8	D981	H-11
D905	I-8	D999	E-10
D907	F-10		
D908	H-11	IC601	F-3
D909	I-10	IC602	I-3
D910	I-8	IC901	F-8
D911	D-1	IC902	H-11
D912	E-1	IC903	F-6
D913	F-1	IC904	C-14
D914	C-5		
D915	C-6	Q601	F-2
D916	E-5	Q602	F-2
D917	D-7	Q603	E-4
D928	H-7	Q604	F-3
D929	H-7	Q605	C-12
D930	E-8	Q621	E-13
D931	E-10	Q651	F-3
D932	E-8	Q652	E-2
D933	D-8	Q661	H-3
D934	D-8	Q662	I-3
D935	E-9	Q671	E-12
D936	E-9	Q681	C-12
D937	E-9	Q901	I-8
D938	D-10	Q902	H-10
D939	C-10	Q911	D-1
D940	C-9	Q912	E-1
D941	C-8	Q913	F-2
D942	D-8	Q914	C-5
D943	D-8	Q915	D-5
D944	C-7	Q916	D-5
D945	D-7	Q921	C-10
D946	D-6	Q922	C-10
D947	C-5	Q923	C-8
D948	E-6	Q924	D-9
D949	C-6	Q925	C-7
D950	D-5	Q926	C-6
D951	D-5	Q927	D-7
D952	D-5	Q942	G-6
D953	D-6		

Note:
 • ○ : parts extracted from the component side.
 • ■ : Pattern on the side which is seen.

• IC Block Diagrams

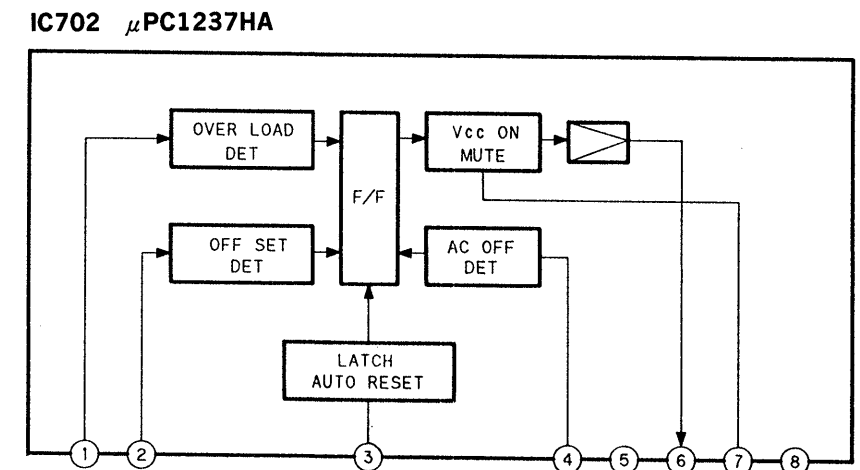
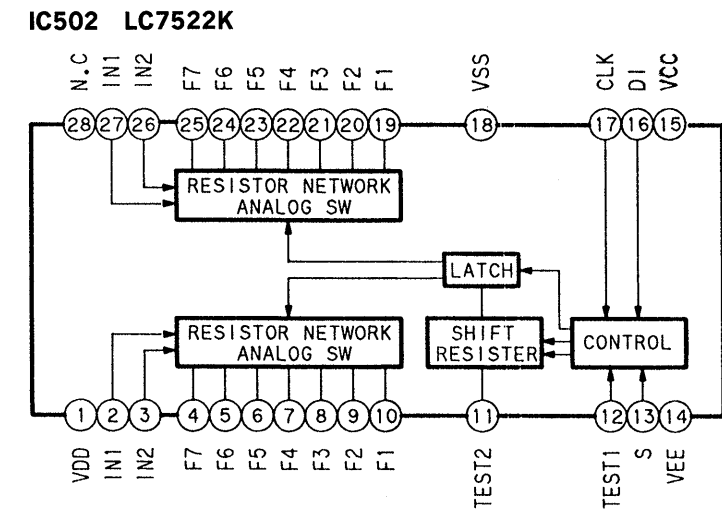
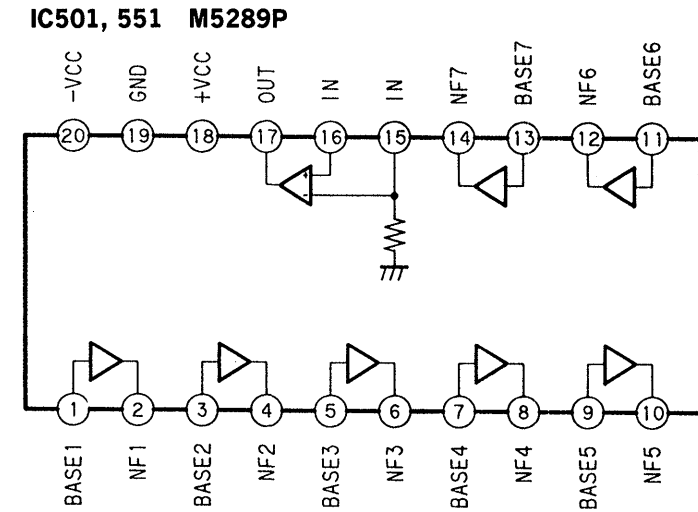
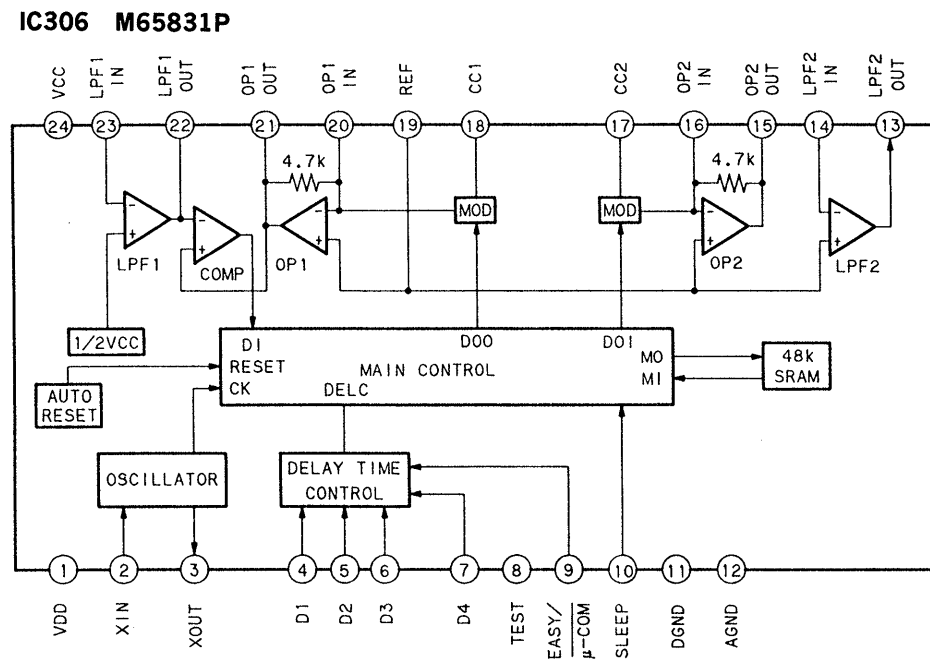
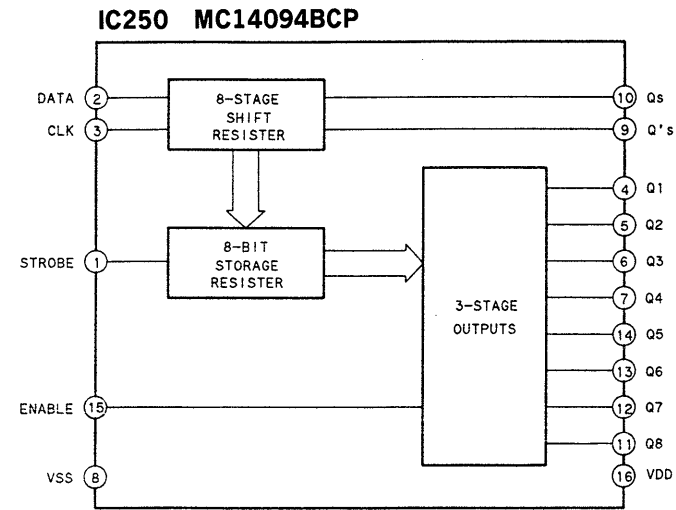
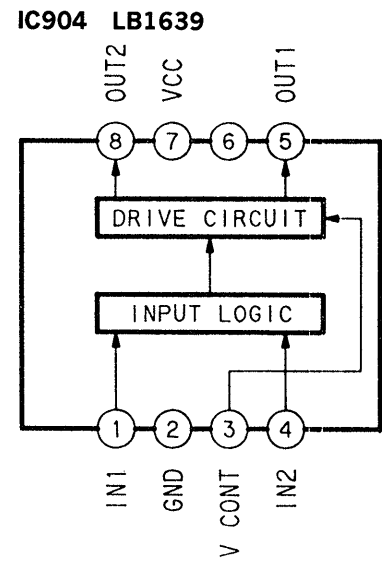
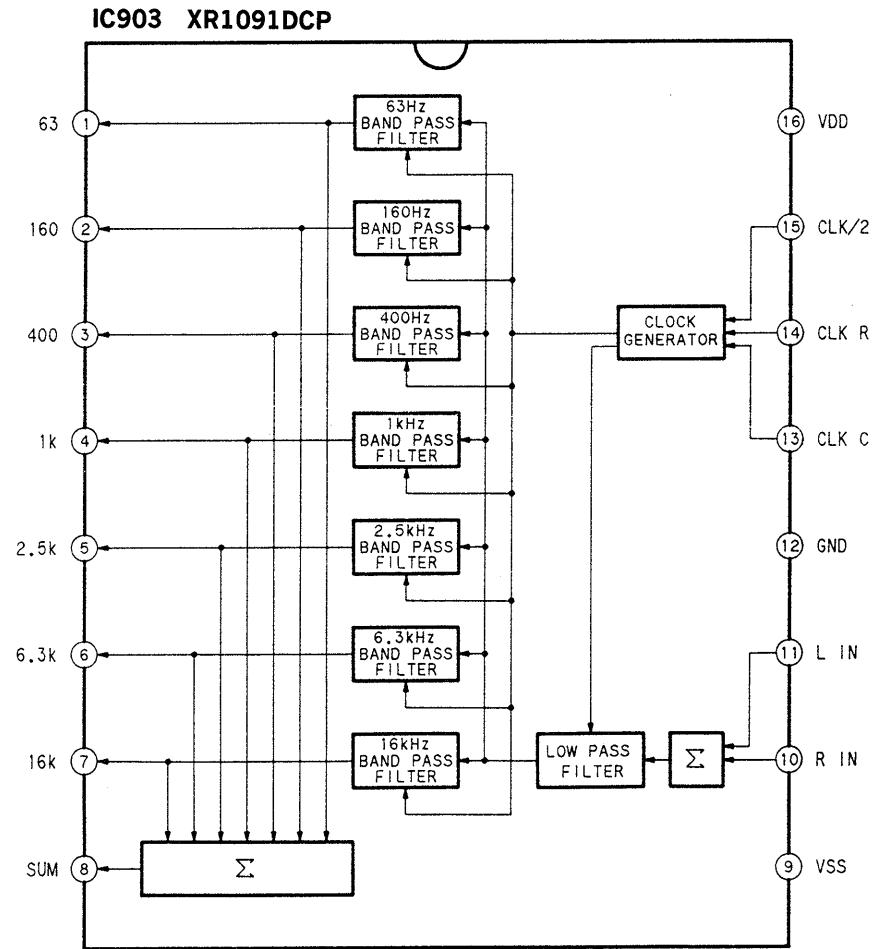

4-2. CHASSIS SECTION

The components identified by mark Δ or dotted line with mark Δ are critical for safety. Replace only with part number specified.

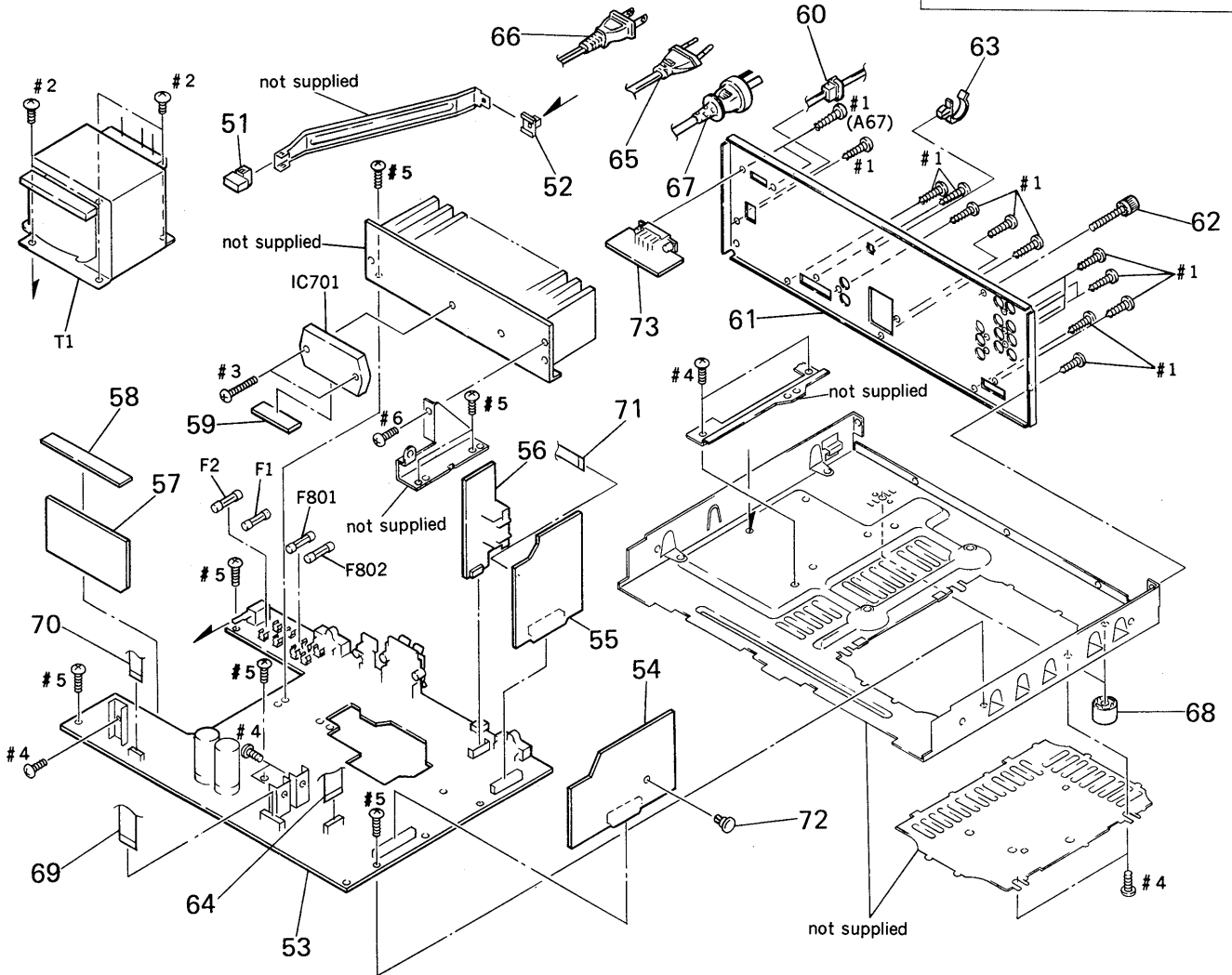

Ref. No.	Part No.	Description	Remark
51	4-942-061-11	BUTTON (POWER)	
52	4-866-342-00	JOINT (B), KNOB	
* 53	A-4360-085-A	MAIN BOARD, COMPLETE (AEP, EE)	
* 53	A-4360-086-A	MAIN BOARD, COMPLETE (G, IT)	
* 53	A-4360-090-A	MAIN BOARD, COMPLETE (E, AUS, EA)	
* 53	A-4360-091-A	MAIN BOARD, COMPLETE (MY, SP)	
* 54	A-4360-832-A	GEQ BOARD, COMPLETE (D609)	
* 54	A-4360-833-A	GEQ BOARD, COMPLETE (A67)	
* 55	A-4360-104-A	PIN JACK BOARD, COMPLETE (D609)	
* 55	A-4360-105-A	PIN JACK BOARD, COMPLETE (A67)	
* 56	1-647-225-11	V1 BOARD	
* 57	1-647-203-11	PS BOARD	
* 58	1-647-204-11	PT BOARD	
* 59	1-647-207-11	IC BOARD	
* 60	3-703-244-00	BUSHING (2104), CORD (AUS, EA, MY, SP, D609)	
* 60	3-703-571-11	BUSHING (S) (4516), CORD (E)	
* 61	4-957-084-11	PANEL (B3120), BACK (AEP, IT, EE)	
* 61	4-957-084-32	PANEL (B3120), BACK (G)	
* 61	4-957-084-41	PANEL (B3120), BACK (E, AUS, EA)	
* 61	4-957-084-51	PANEL (B3120), BACK (MY, SP)	
62	4-947-010-01	SCREW, FEEDER FIXED	

Ref. No.	Part No.	Description	Remark
* 63	4-949-235-01	HOOK	
64	1-751-209-11	WIRE, FLAT TYPE (9 CORE)	
Δ 65	1-575-654-11	CORD, POWER (EA, MY, SP, D609)	
Δ 66	1-575-656-11	CORD, POWER (E)	
Δ 67	1-751-355-11	CORD, POWER (AUS)	
68	4-931-169-01	FOOT	
69	1-690-094-11	WIRE, FLAT TYPE (15 CORE)	
70	1-690-992-11	WIRE, FLAT TYPE (7 CORE)	
71	1-690-066-31	WIRE, FLAT TYPE (5 CORE)	
72	3-531-576-21	RIVET	
* 73	1-647-206-11	DENGEN SW BOARD (A67)	
Δ F1	1-532-259-00	FUSE, TIME-LAG (T1. 6A) (A67)	
Δ F1	1-532-286-00	FUSE, TIME-LAG (T2. 5A) (D609)	
Δ F2	1-532-259-00	FUSE, TIME-LAG (T1. 6A) (A67)	
Δ F801	1-532-203-00	FUSE, TIME-LAG (T2A)	
Δ F802	1-532-203-00	FUSE, TIME-LAG (T2A)	
IC701	8-749-922-94	IC STK401-080 (D609)	
IC701	8-749-922-95	IC STK401-090 (A67)	
Δ T1	1-423-529-11	TRANSFORMER, POWER (D609)	
Δ T1	1-423-530-11	TRANSFORMER, POWER (E, AUS, EA, MY)	
Δ T1	1-423-603-11	TRANSFORMER, POWER (SP)	

SECTION 5

ELECTRICAL PARTS LIST

DENGEN SW

GEQ

NOTE:

- Due to standardization, replacements in the parts list may be different from the parts specified in the diagrams or the components used on the set.
- -XX and -X mean standardized parts, so they may have some difference from the original one.
- RESISTORS
All resistors are in ohms.
METAL: Metal-film resistor.
METAL OXIDE: Metal oxide-film resistor.
F: nonflammable

- Items marked "*" are not stocked since they are seldom required for routine service. Some delay should be anticipated when ordering these items.
- SEMICONDUCTORS
In each case, u: μ , for example:
uA ..: μ A. uPA.: μ PA..
uPB.: μ PB. uPC.: μ PC. uPD.: μ PD..
- CAPACITORS
uF: μ F
- COILS
uH: μ H

The components identified by mark Δ or dotted line with mark Δ are critical for safety. Replace only with part number specified.

- Abbreviations
AUS : Australian model
EA : Saudi Arabia model
D609 : TA-D609
MY : Malaysia model
SP : Singapore model
A67 : TA-A67
EE : East European model
G : German model
IT : Italian model

When indicating parts by reference number, please include the board.

Ref. No.	Part No.	Description	Remark
*	1-647-206-11	DENGEN SW BOARD (A67) ***** < CONNECTOR >	
* CN3	1-573-565-11	PIN, CONNECTOR 5P (A67) < SWITCH >	
Δ VS1	1-572-009-11	SELECTOR, VOLTAGE (VOLTAGE SELECTOR) (A67)	

*	A-4360-832-A	GEQ BOARD, COMPLETE (D609)	
*	A-4360-833-A	GEQ BOARD, COMPLETE (A67) ***** < CAPACITOR >	
C505	1-162-286-31	CERAMIC 220PF	10% 50V
C506	1-126-163-11	ELECT 4.7uF	20% 50V
C507	1-136-177-00	FILM 1uF	5% 50V
C508	1-136-163-00	FILM 0.068uF	5% 50V
C509	1-136-173-00	FILM 0.47uF	5% 50V
C510	1-136-158-00	FILM 0.027uF	5% 50V
C511	1-130-479-00	MYLAR 0.0047uF	5% 50V
C512	1-110-340-11	MYLAR 270PF	5% 50V
C513	1-130-484-00	MYLAR 0.012uF	5% 50V
C514	1-130-469-00	MYLAR 680PF	5% 50V
C515	1-136-159-00	FILM 0.033uF	5% 50V
C516	1-130-474-00	MYLAR 0.0018uF	5% 50V
C517	1-136-163-00	FILM 0.068uF	5% 50V
C518	1-130-478-00	MYLAR 0.0039uF	5% 50V
C519	1-136-168-00	FILM 0.18uF	5% 50V
C520	1-136-153-00	FILM 0.01uF	5% 50V
C521	1-124-034-51	ELECT 33uF	20% 16V
C523	1-162-282-31	CERAMIC 100PF	10% 50V
C524	1-162-282-31	CERAMIC 100PF	10% 50V
C525	1-126-163-11	ELECT 4.7uF	20% 50V
C526	1-164-159-11	CERAMIC 0.1uF	50V
C527	1-124-034-51	ELECT 33uF	20% 16V
C528	1-136-169-00	FILM 0.22uF (A67)	5% 50V

Ref. No.	Part No.	Description	Remark
C529	1-164-159-11	CERAMIC 0.1uF	50V
C530	1-164-159-11	CERAMIC 0.1uF	50V
C531	1-126-163-11	ELECT 4.7uF (A67)	20% 50V
C532	1-124-034-51	ELECT 33uF	20% 16V
C533	1-124-034-51	ELECT 33uF	20% 16V
C534	1-162-219-31	CERAMIC 68PF (A67)	5% 50V
C535	1-130-471-00	MYLAR 0.001uF (A67)	5% 50V
C555	1-162-286-31	CERAMIC 220PF	10% 50V
C556	1-126-163-11	ELECT 4.7uF	20% 50V
C557	1-136-173-00	FILM 0.47uF	5% 50V
C558	1-136-158-00	FILM 0.027uF	5% 50V
C559	1-136-177-00	FILM 1uF	5% 50V
C560	1-136-163-00	FILM 0.068uF	5% 50V
C561	1-130-484-00	MYLAR 0.012uF	5% 50V
C562	1-130-469-00	MYLAR 680PF	5% 50V
C563	1-130-479-00	MYLAR 0.0047uF	5% 50V
C564	1-110-340-11	MYLAR 270PF	5% 50V
C565	1-136-159-00	FILM 0.033uF	5% 50V
C566	1-130-474-00	MYLAR 0.0018uF	5% 50V
C567	1-136-163-00	FILM 0.068uF	5% 50V
C568	1-130-478-00	MYLAR 0.0039uF	5% 50V
C569	1-136-168-00	FILM 0.18uF	5% 50V
C570	1-136-153-00	FILM 0.01uF	5% 50V
C571	1-124-034-51	ELECT 33uF	20% 16V
C575	1-126-163-11	ELECT 4.7uF	20% 50V
C578	1-136-169-00	FILM 0.22uF (A67)	5% 50V
C579	1-164-159-11	CERAMIC 0.1uF	50V
C580	1-164-159-11	CERAMIC 0.1uF	50V
< CONNECTOR >			
CN102	1-691-185-11	CONNECTOR (BOARD TO BOARD) 15P	
< DIODE >			
D501	8-719-000-54	DIODE UZL-6L3	
D502	8-719-987-63	DIODE 1N4148M (A67)	

Ref. No.	Part No.	Description	Remark
		< IC >	
IC501	8-759-633-78	IC M5289P	
IC502	8-759-822-26	IC LC7522K	
IC503	8-759-636-73	IC M5218AL-22 (A67)	
IC551	8-759-633-78	IC M5289P	
		< TRANSISTOR >	
Q504	8-729-224-62	TRANSISTOR 2SK246-GR (A67)	
Q510	8-729-900-63	TRANSISTOR DTA124ES (A67)	
Q554	8-729-224-62	TRANSISTOR 2SK246-GR (A67)	
		< RESISTOR >	
R507	1-247-887-00	CARBON 220K 5% 1/4W	
R508	1-249-427-11	CARBON 6.8K 5% 1/4W	
R509	1-249-427-11	CARBON 6.8K 5% 1/4W	
R510-516			
	1-247-903-00	CARBON 1M 5% 1/4W	
R517	1-249-408-11	CARBON 180 5% 1/4W	
R518	1-249-417-11	CARBON 1K 5% 1/4W	
R519	1-249-417-11	CARBON 1K 5% 1/4W	
R520	1-249-435-11	CARBON 33K 5% 1/4W	
R525	1-249-429-11	CARBON 10K 5% 1/4W (A67)	
R529	1-249-429-11	CARBON 10K 5% 1/4W (A67)	
R530	1-249-413-11	CARBON 470 5% 1/4W (A67)	
R531-533			
	1-249-429-11	CARBON 10K 5% 1/4W (A67)	
R534	1-249-427-11	CARBON 6.8K 5% 1/4W (A67)	
R535	1-247-895-00	CARBON 470K 5% 1/4W (A67)	
R536	1-249-441-11	CARBON 100K 5% 1/4W (A67)	
R557	1-247-887-00	CARBON 220K 5% 1/4W	
R558	1-249-427-11	CARBON 6.8K 5% 1/4W	
R559	1-249-427-11	CARBON 6.8K 5% 1/4W	
R560-566			
	1-247-903-00	CARBON 1M 5% 1/4W	
R570	1-249-435-11	CARBON 33K 5% 1/4W	
R575	1-249-429-11	CARBON 10K 5% 1/4W (A67)	
R584	1-249-427-11	CARBON 6.8K 5% 1/4W (A67)	
R585	1-247-895-00	CARBON 470K 5% 1/4W (A67)	

*	1-647-207-11	IC BOARD	

		< IC >	
IC701	8-749-922-94	IC STK401-080 (D609)	
IC701	8-749-922-95	IC STK401-090 (A67)	

Ref. No.	Part No.	Description	Remark
*	A-4360-103-A	JACK BOARD, COMPLETE	

		< CAPACITOR >	
C421	1-162-294-31	CERAMIC 0.001uF 10% 50V	
C422	1-136-167-00	FILM 0.15uF 5% 50V	
C423	1-162-219-31	CERAMIC 68PF 5% 50V	
C424	1-162-286-31	CERAMIC 220PF 10% 50V	
C425	1-126-163-11	ELECT 4.7uF 20% 50V	
C426	1-126-163-11	ELECT 4.7uF 20% 50V	
C427	1-162-286-31	CERAMIC 220PF 10% 50V	
C428	1-126-163-11	ELECT 4.7uF 20% 50V	
C429	1-124-034-51	ELECT 33uF 20% 16V	
C430	1-124-034-51	ELECT 33uF 20% 16V	
C431	1-162-306-11	CERAMIC 0.01uF 20% 16V	
		< CONNECTOR >	
* CN401	1-568-826-11	SOCKET, CONNECTOR 7P	
CN709	1-691-767-11	PLUG (MICRO CONNECTOR) 5P	
		< IC >	
IC421	8-759-636-73	IC M5218AL-22	
		< JACK >	
J401	1-507-854-00	JACK, PHONE (MIC)	
J702	1-507-854-00	JACK, PHONE (HEADPHONES)	
		< RESISTOR >	
R421	1-249-441-11	CARBON 100K 5% 1/4W	
R422	1-249-429-11	CARBON 10K 5% 1/4W	
R423	1-249-417-11	CARBON 1K 5% 1/4W	
R424	1-249-440-11	CARBON 82K 5% 1/4W	
R425	1-249-429-11	CARBON 10K 5% 1/4W	
R426	1-249-427-11	CARBON 6.8K 5% 1/4W	
R427	1-249-440-11	CARBON 82K 5% 1/4W	
R428	1-249-409-11	CARBON 220 5% 1/4W	
R429	1-249-429-11	CARBON 10K 5% 1/4W	
R430	1-249-405-11	CARBON 100 5% 1/4W	
R432	1-249-405-11	CARBON 100 5% 1/4W	
R725	1-247-749-11	CARBON 560 5% 1/2W	
R775	1-247-749-11	CARBON 560 5% 1/2W	
		< VARIABLE RESISTOR >	
RV421	1-223-334-11	RES, VAR, CARBON 50K (MIC LEVEL)	

Ref.No.	Part No.	Description	Remark		
*	1-647-221-11	JW1 BOARD *****			

*	A-4360-085-A	MAIN BOARD, COMPLETE (AEP, EE)			
*	A-4360-086-A	MAIN BOARD, COMPLETE (G, IT)			
*	A-4360-090-A	MAIN BOARD, COMPLETE (E, AUS, EA)			
*	A-4360-091-A	MAIN BOARD, COMPLETE (MY, SP) *****			
*	1-533-293-11	FUSE HOLDER			
*	3-309-144-31	HEAT SINK			
*	4-941-237-01	HEAT SINK			
*	4-942-204-01	PLATE, GROUND			
	7-685-871-01	SCREW +BVTT 3X6 (S)			
< CAPACITOR >					
△C1	1-161-744-00	CERAMIC	0.01uF		400V
C302	1-162-207-31	CERAMIC	22PF	5%	50V
C303	1-126-301-11	ELECT	1uF	20%	50V
C304	1-130-480-00	MYLAR	0.0056uF	5%	50V
C305	1-162-291-31	CERAMIC	560PF	10%	50V
C306	1-164-159-11	CERAMIC	0.1uF		50V
C307	1-124-910-11	ELECT	47uF	20%	50V
C308-310					
	1-164-159-11	CERAMIC	0.1uF		50V
C311	1-161-374-11	CERAMIC	0.0015uF	20%	50V
C312	1-130-480-00	MYLAR	0.0056uF	5%	50V
C313	1-126-301-11	ELECT	1uF	20%	50V
C314	1-164-159-11	CERAMIC	0.1uF		50V
C315	1-164-159-11	CERAMIC	0.1uF		50V
C316	1-124-994-11	ELECT	100uF	20%	10V
C317	1-162-219-31	CERAMIC	68PF	5%	50V
C352	1-162-207-31	CERAMIC	22PF	5%	50V
C401	1-162-286-31	CERAMIC	220PF	10%	50V
C451	1-162-286-31	CERAMIC	220PF	10%	50V
C701	1-126-161-11	ELECT	2.2uF	20%	50V
C702	1-162-282-31	CERAMIC	100PF	10%	50V
C703	1-162-286-31	CERAMIC	220PF	10%	50V
C704	1-124-994-11	ELECT	100uF	20%	10V
C706	1-124-122-11	ELECT (D609)	100uF	20%	50V
C706	1-124-572-11	ELECT (A67)	100uF	20%	63V
C707	1-124-122-11	ELECT (D609)	100uF	20%	50V
C707	1-124-572-11	ELECT (A67)	100uF	20%	63V
C708	1-136-163-00	FILM	0.068uF	5%	50V
C709	1-136-163-00	FILM	0.068uF	5%	50V
C710	1-124-587-11	ELECT	220uF	20%	6.3V

Ref.No.	Part No.	Description	Remark		
C711	1-124-587-11	ELECT	220uF	20%	6.3V
C712	1-124-994-11	ELECT	100uF	20%	10V
C713	1-136-163-00	FILM	0.068uF	5%	50V
C714	1-136-163-00	FILM	0.068uF	5%	50V
C715	1-162-199-31	CERAMIC	10PF	5%	50V
C716	1-162-291-31	CERAMIC (G, IT)	560PF	10%	50V
C717	1-162-291-31	CERAMIC (G, IT)	560PF	10%	50V
C719	1-164-159-11	CERAMIC (G, IT)	0.1uF		50V
C721	1-161-494-00	CERAMIC (G, IT)	0.022uF		25V
C722	1-164-159-11	CERAMIC (G, IT)	0.1uF		50V
C723	1-164-159-11	CERAMIC (G, IT)	0.1uF		50V
C724	1-161-377-00	CERAMIC (G, IT)	0.0047uF	30%	16V
C725	1-164-159-11	CERAMIC (G, IT)	0.1uF		50V
C751	1-126-161-11	ELECT	2.2uF	20%	50V
C752	1-162-282-31	CERAMIC	100PF	10%	50V
C753	1-162-286-31	CERAMIC	220PF	10%	50V
C754	1-124-994-11	ELECT	100uF	20%	10V
C758	1-136-163-00	FILM	0.068uF	5%	50V
C759	1-136-163-00	FILM	0.068uF	5%	50V
C763	1-136-163-00	FILM	0.068uF	5%	50V
C764	1-136-163-00	FILM	0.068uF	5%	50V
C765	1-162-199-31	CERAMIC	10PF	5%	50V
C801	1-126-138-11	ELECT (D609)	4700uF	20%	50V
C801	1-126-258-11	ELECT (A67)	4700uF	20%	56V
C802	1-126-138-11	ELECT (D609)	4700uF	20%	50V
C802	1-126-258-11	ELECT (A67)	4700uF	20%	56V
C803	1-124-910-11	ELECT	47uF	20%	50V
C804	1-124-910-11	ELECT	47uF	20%	50V
C807	1-126-059-11	ELECT	10uF	20%	50V
C808	1-126-059-11	ELECT	10uF	20%	50V
C809	1-124-994-11	ELECT	100uF	20%	10V
C810	1-124-994-11	ELECT	100uF	20%	10V
C816	1-164-159-11	CERAMIC (G, IT)	0.1uF		50V
C818	1-161-021-11	CERAMIC	0.047uF	10%	25V
C819	1-161-021-11	CERAMIC	0.047uF	10%	25V
C823	1-126-059-11	ELECT	10uF	20%	50V
C824	1-126-696-11	ELECT	33uF	20%	35V
C825	1-126-059-11	ELECT	10uF	20%	50V

The components identified by mark △ or dotted line with mark △ are critical for safety. Replace only with part number specified.

Ref. No.	Part No.	Description	Remark
< FILTER >			
CF301	1-579-649-11	VIBRATOR, CERAMIC (2MHz)	
< CONNECTOR >			
* CN1	1-564-321-00	PIN, CONNECTOR 2P	
CN2	1-535-139-00	BASE POST 22MM (10MM PITCH) 2P (D609)	
* CN2	1-535-140-00	BASE POST 22MM (10MM PITCH) 3P (A67)	
* CN301	1-566-858-41	SOCKET, CONNECTOR 11P (SYSTEM CONTROL 1)	
* CN302	1-568-826-11	SOCKET, CONNECTOR 7P	
* CN303	1-568-834-11	SOCKET, CONNECTOR 15P	
CN501	1-691-170-11	PIN, CONNECTOR 13P	
CN502	1-691-163-11	PIN, CONNECTOR 6P	
CN503	1-691-172-11	PIN, CONNECTOR 15P	
* CN601	1-568-828-11	SOCKET, CONNECTOR 9P	
* CN702	1-564-506-11	PLUG, CONNECTOR 3P	
CN707	1-691-767-11	PLUG (MICRO CONNECTOR) 5P	
* CN801	1-566-859-11	SOCKET, CONNECTOR 15P (SYSTEM CONTROL 2)	
< DIODE >			
D201	8-719-987-63	DIODE 1N4148M	
D202	8-719-987-63	DIODE 1N4148M	
D301-305			
	8-719-987-63	DIODE 1N4148M	
D701-705			
	8-719-987-63	DIODE 1N4148M	
D802-805			
	8-719-933-50	DIODE HZS7C2L	
D813	8-719-987-63	DIODE 1N4148M	
D814	8-719-987-63	DIODE 1N4148M	
D822	8-719-934-22	DIODE HZS30-2L	
D823	8-719-014-74	DIODE UZP-6. 2B	
< IC >			
IC103	8-759-140-53	IC MC14053BCP	
IC250	8-759-202-61	IC TC4094BP	
IC301	8-759-000-49	IC MC14066BCP	
IC302	8-759-634-51	IC M5218AP	
IC303	8-759-634-50	IC M5218AL	
IC304	8-759-634-50	IC M5218AL	
IC306	8-759-053-12	IC M65831P	
IC401	8-759-000-48	IC MC14052BCP	
IC702	8-759-111-68	IC uPC1237HA	
IC801	8-759-071-48	IC TA7807S	
IC802	8-759-604-95	IC M5F79M07	
< JACK >			
* J701	1-569-130-11	JACK, PIN 2P (SURROUND SPEAKER)	

Ref. No.	Part No.	Description	Remark
< COIL >			
L301	1-410-171-11	INDUCTOR 1mH	
* L701	1-420-872-00	COIL, AIR CORE	
* L751	1-420-872-00	COIL, AIR CORE	
< TRANSISTOR >			
Q250	8-729-900-80	TRANSISTOR DTC114ES	
Q251	8-729-900-80	TRANSISTOR DTC114ES	
Q252	8-729-620-05	TRANSISTOR 2SC2603-EF	
Q301-303			
	8-729-900-63	TRANSISTOR DTA124ES	
Q304	8-729-900-80	TRANSISTOR DTC114ES	
Q305	8-729-620-05	TRANSISTOR 2SC2603-EF	
Q701	8-729-140-84	TRANSISTOR 2SC1841-PAFAEA	
Q702	8-729-900-63	TRANSISTOR DTA124ES	
Q751	8-729-140-84	TRANSISTOR 2SC1841-PAFAEA	
Q801	8-729-141-83	TRANSISTOR 2SB1094-LK	
< RESISTOR >			
R121	1-249-405-11	CARBON 100 5% 1/4W	
R171	1-249-405-11	CARBON 100 5% 1/4W	
R220	1-249-425-11	CARBON 4. 7K 5% 1/4W	
R250-252			
	1-249-413-11	CARBON 470 5% 1/4W	
R253	1-249-425-11	CARBON 4. 7K 5% 1/4W	
R254	1-249-429-11	CARBON 10K 5% 1/4W	
R255	1-249-429-11	CARBON 10K 5% 1/4W	
R258	1-249-413-11	CARBON 470 5% 1/4W (A67)	
R301	1-247-897-11	CARBON 560K 5% 1/4W	
R303	1-247-897-11	CARBON 560K 5% 1/4W	
R304-309			
	1-249-429-11	CARBON 10K 5% 1/4W	
R310	1-249-399-11	CARBON 33 5% 1/4W	
R311	1-249-399-11	CARBON 33 5% 1/4W	
R312	1-249-425-11	CARBON 4. 7K 5% 1/4W	
R313	1-249-429-11	CARBON 10K 5% 1/4W	
R314	1-249-429-11	CARBON 10K 5% 1/4W	
R315	1-249-431-11	CARBON 15K 5% 1/4W	
R316	1-249-431-11	CARBON 15K 5% 1/4W	
R317	1-249-429-11	CARBON 10K 5% 1/4W	
R318	1-249-431-11	CARBON 15K 5% 1/4W	
R319	1-249-431-11	CARBON 15K 5% 1/4W	
R320	1-247-848-11	CARBON 5. 1K 5% 1/4W	
R321	1-249-417-11	CARBON 1K 5% 1/4W	
R322	1-249-429-11	CARBON 10K 5% 1/4W	
R323	1-249-429-11	CARBON 10K 5% 1/4W	
R324-326			
	1-249-417-11	CARBON 1K 5% 1/4W	

MAIN

PANEL

Ref. No.	Part No.	Description	Remark		
R327-329					
	1-249-433-11	CARBON	22K	5%	1/4W
R330	1-247-903-00	CARBON	1M	5%	1/4W
R331	1-249-425-11	CARBON	4.7K	5%	1/4W
R332	1-249-429-11	CARBON	10K	5%	1/4W
R333	1-249-436-11	CARBON	39K	5%	1/4W
R334	1-249-417-11	CARBON	1K	5%	1/4W
R351	1-247-897-11	CARBON	560K	5%	1/4W
R353	1-247-897-11	CARBON	560K	5%	1/4W
R354-359					
	1-249-429-11	CARBON	10K	5%	1/4W
R401	1-249-417-11	CARBON	1K	5%	1/4W
R402	1-249-417-11	CARBON	1K	5%	1/4W
R403	1-249-413-11	CARBON	470	5%	1/4W
R404	1-249-405-11	CARBON	100	5%	1/4W
R451	1-249-417-11	CARBON	1K	5%	1/4W
R452	1-249-417-11	CARBON	1K	5%	1/4W
R453	1-249-413-11	CARBON	470	5%	1/4W
R454	1-249-405-11	CARBON	100	5%	1/4W
R461-463					
	1-249-417-11	CARBON	1K	5%	1/4W
R701	1-249-417-11	CARBON	1K	5%	1/4W
R702	1-249-438-11	CARBON	56K	5%	1/4W
R703	1-249-413-11	CARBON	470	5%	1/4W
R704	1-249-438-11	CARBON	56K	5%	1/4W
△R705	1-212-881-11	FUSIBLE	100	5%	1/4W F
△R706	1-212-881-11	FUSIBLE	100	5%	1/4W F
R707	1-249-417-11	CARBON	1K	5%	1/4W
R708	1-249-430-11	CARBON	12K	5%	1/4W
R709	1-249-441-11	CARBON	100K	5%	1/4W
△R710	1-217-156-00	RES, METAL PLATE	0.22	5W	
R711	1-247-727-11	CARBON	10	5%	1/2W
R712	1-247-727-11	CARBON	10	5%	1/2W
R713	1-249-437-11	CARBON	47K	5%	1/4W
R714	1-249-429-11	CARBON	10K	5%	1/4W
R715	1-249-441-11	CARBON	100K	5%	1/4W
R716	1-249-417-11	CARBON	1K	5%	1/4W
R718	1-249-437-11	CARBON	47K	5%	1/4W
R719	1-249-486-11	CARBON	12K	5%	1/2W
△R720	1-216-456-00	METAL OXIDE (D609)	820	5%	2W F
△R720	1-216-457-00	METAL OXIDE (A67)	1.2K	5%	2W F
R721	1-247-727-11	CARBON	10	5%	1/2W
R751	1-249-417-11	CARBON	1K	5%	1/4W
R752	1-249-438-11	CARBON	56K	5%	1/4W
R753	1-249-413-11	CARBON	470	5%	1/4W
R754	1-249-438-11	CARBON	56K	5%	1/4W
R757	1-249-417-11	CARBON	1K	5%	1/4W
R758	1-249-430-11	CARBON	12K	5%	1/4W

Ref. No.	Part No.	Description	Remark		
R759	1-249-441-11	CARBON	100K	5%	1/4W
△R760	1-217-156-00	RES, METAL PLATE	0.22	5W	
R761	1-247-727-11	CARBON	10	5%	1/2W
R762	1-247-727-11	CARBON	10	5%	1/2W
R763	1-249-437-11	CARBON	47K	5%	1/4W
R771	1-247-727-11	CARBON	10	5%	1/2W
△R801	1-216-481-11	METAL OXIDE	1.2K	5%	3W F
△R802	1-216-481-11	METAL OXIDE	1.2K	5%	3W F
R805	1-247-761-11	CARBON	5.6K	5%	1/2W
R806	1-249-421-11	CARBON	2.2K	5%	1/4W
		< RELAY >			
RY701	1-515-765-11	RELAY			
		< SWITCH >			
△S1	1-554-920-51	SWITCH, PUSH (AC POWER) (1 KEY) (POWER)			
		< TERMINAL >			
TM701	1-537-240-11	TERMINAL BOARD (CHECKER PIN) (SPEAKER)			

*	A-4360-098-A	PANEL BOARD, COMPLETE (D609)			
*	A-4360-099-A	PANEL BOARD, COMPLETE (A67)			

*	4-934-853-01	CUSHION			
*	4-950-649-01	HOLDER, FL TUBE			
		< CAPACITOR >			
C601	1-126-161-11	ELECT	2.2uF	20%	50V
C602	1-162-282-31	CERAMIC	100PF	10%	50V
C603	1-162-282-31	CERAMIC	100PF	10%	50V
C604	1-126-161-11	ELECT	2.2uF	20%	50V
C605	1-126-300-11	ELECT	0.47uF	20%	50V
C606	1-124-250-00	ELECT	0.15uF	20%	50V
C607	1-126-301-11	ELECT	1uF	20%	50V
C608	1-126-059-11	ELECT	10uF	20%	50V
C609	1-126-059-11	ELECT	10uF	20%	50V
C611	1-164-159-11	CERAMIC	0.1uF		50V
C612	1-164-159-11	CERAMIC	0.1uF		50V
C651	1-126-161-11	ELECT	2.2uF	20%	50V
C652	1-162-282-31	CERAMIC	100PF	10%	50V
C653	1-162-282-31	CERAMIC	100PF	10%	50V
C654	1-126-161-11	ELECT	2.2uF	20%	50V
C655	1-126-300-11	ELECT	0.47uF	20%	50V
C656	1-124-250-00	ELECT	0.15uF	20%	50V
C657	1-126-301-11	ELECT	1uF	20%	50V
C902	1-125-486-11	DOUBLE LAYERS	0.22F		5.5V
C905	1-161-379-00	CERAMIC	0.01uF	20%	25V

The components identified by mark △ or dotted line with mark. △ are critical for safety. Replace only with part number specified.

Ref. No.	Part No.	Description	Remark
C909	1-164-159-11	CERAMIC 0.1uF	50V
C911	1-164-159-11	CERAMIC 0.1uF	50V
C912	1-164-159-11	CERAMIC 0.1uF	50V
C921	1-162-294-31	CERAMIC 0.001uF	10% 50V
C922	1-164-159-11	CERAMIC 0.1uF	50V
C924	1-164-159-11	CERAMIC 0.1uF	50V
C941-947			
	1-162-290-31	CERAMIC 470PF	10% 50V
C961	1-162-291-31	CERAMIC 560PF	10% 50V
< FILTER >			
CF901	1-577-101-11	VIBRATOR, CERAMIC (4.19MHz)	
< COMPOSITION CIRCUIT BLOCK >			
CP901	1-232-998-11	COMPOSITION CIRCUIT BLOCK (100kX7)	
CP902-904			
	1-236-985-11	COMPOSITION CIRCUIT BLOCK (100kX9)	
< DIODE >			
D601	8-719-987-63	DIODE 1N4148M	
D602	8-719-026-72	LED SML1860A (DYNAMIC BASS SYSTEM ON/OFF)	
D603	8-719-026-72	LED SML1860A (DYNAMIC BASS SYSTEM ON/OFF)	
D651	8-719-987-63	DIODE 1N4148M	
D684	8-719-987-63	DIODE 1N4148M	
D907	8-719-987-63	DIODE 1N4148M	
D911	8-719-313-69	LED SEL3210S-CD (P. FUNCTION)	
D912	8-719-313-69	LED SEL3210S-CD (EFFECT)	
D913	8-719-313-69	LED SEL3210S-CD (KARAOKE PON) (A67)	
D914	8-719-018-46	LED SEL3510C-CD (VIDEO 1)	
D915	8-719-018-46	LED SEL3510C-CD (VIDEO 2)	
D916	8-719-026-72	LED SML1860A (DIGITAL SURROUND ON/OFF)	
D917	8-719-313-69	LED SEL3210S-CD (CD DIRECT)	
D930-938			
	8-719-987-63	DIODE 1N4148M	
D939	8-719-313-69	LED SEL3210S-CD (PHONO)	
D940	8-719-313-69	LED SEL3210S-CD (TUNER)	
D941	8-719-313-69	LED SEL3210S-CD (CD)	
D942	8-719-313-69	LED SEL3210S-CD (MEMORY)	
D943	8-719-313-69	LED SEL3210S-CD (CURSOR MODE PERSONAL FILE)	
D944	8-719-313-69	LED SEL3210S-CD (TAPE)	
D950-957			
	8-719-987-63	DIODE 1N4148M	
D960	8-719-987-63	DIODE 1N4148M	
D961	8-719-987-63	DIODE 1N4148M	
D966	8-719-987-63	DIODE 1N4148M	
D999	8-719-987-63	DIODE 1N4148M	

Ref. No.	Part No.	Description	Remark
< FLUORESCENT INDICATOR >			
FL901	1-517-152-11	INDICATOR TUBE, FLUORESCENT	
< IC >			
IC601	8-759-634-50	IC M5218AL	
IC901	8-759-164-69	IC uPD78042GF-018-3B9	
IC903	8-759-991-11	IC XR1091DCP	
< TRANSISTOR >			
Q601	8-729-224-62	TRANSISTOR 2SK246-GR	
Q602	8-729-620-05	TRANSISTOR 2SC2603-EF	
Q603	8-729-900-36	TRANSISTOR DTC124ES	
Q604	8-729-900-61	TRANSISTOR DTA114ES	
Q651	8-729-224-62	TRANSISTOR 2SK246-GR	
Q652	8-729-620-05	TRANSISTOR 2SC2603-EF	
Q911	8-729-900-80	TRANSISTOR DTC114ES	
Q912	8-729-900-80	TRANSISTOR DTC114ES	
Q913	8-729-900-80	TRANSISTOR DTC114ES (A67)	
Q914-916			
	8-729-900-80	TRANSISTOR DTC114ES	
Q921-923			
	8-729-900-80	TRANSISTOR DTC114ES	
Q924-927			
	8-729-620-05	TRANSISTOR 2SC2603-EF	
Q942	8-729-141-26	TRANSISTOR 2SC3622A-LK	
< RESISTOR >			
R601	1-249-441-11	CARBON 100K 5%	1/4W
R602	1-249-429-11	CARBON 10K 5%	1/4W
R603	1-247-903-00	CARBON 1M 5%	1/4W
R604	1-249-420-11	CARBON 1.8K 5%	1/4W
R605	1-249-434-11	CARBON 27K 5%	1/4W
R606	1-247-881-00	CARBON 120K 5%	1/4W
R607	1-249-412-11	CARBON 390 5%	1/4W
R608	1-249-427-11	CARBON 6.8K 5%	1/4W
R611	1-249-415-11	CARBON 680 5%	1/4W
R612	1-249-441-11	CARBON 100K 5%	1/4W
R613	1-249-435-11	CARBON 33K 5%	1/4W
R614	1-249-425-11	CARBON 4.7K 5%	1/4W
R622	1-249-425-11	CARBON 4.7K 5%	1/4W
R651	1-249-441-11	CARBON 100K 5%	1/4W
R652	1-249-429-11	CARBON 10K 5%	1/4W
R653	1-247-903-00	CARBON 1M 5%	1/4W
R654	1-249-420-11	CARBON 1.8K 5%	1/4W
R655	1-249-434-11	CARBON 27K 5%	1/4W
R656	1-247-881-00	CARBON 120K 5%	1/4W
R657	1-249-412-11	CARBON 390 5%	1/4W
R658	1-249-427-11	CARBON 6.8K 5%	1/4W

PANEL

PIN JACK

Ref. No.	Part No.	Description	Remark		
R681	1-249-433-11	CARBON	22K	5%	1/4W
R911	1-249-416-11	CARBON	820	5%	1/4W
R912	1-249-416-11	CARBON	820	5%	1/4W
R913	1-249-416-11	CARBON	820	5%	1/4W (A67)
R914	1-249-408-11	CARBON	180	5%	1/4W
R915	1-249-408-11	CARBON	180	5%	1/4W
R916	1-249-409-11	CARBON	220	5%	1/4W
R917	1-249-413-11	CARBON	470	5%	1/4W
R923-925					
	1-249-441-11	CARBON	100K	5%	1/4W
R927	1-249-441-11	CARBON	100K	5%	1/4W
R928	1-249-396-11	CARBON	18	5%	1/6W
R929	1-249-441-11	CARBON	100K	5%	1/4W
R930	1-249-396-11	CARBON	18	5%	1/6W
R931	1-249-441-11	CARBON	100K	5%	1/4W
R932	1-249-396-11	CARBON	18	5%	1/6W
R933	1-249-441-11	CARBON	100K	5%	1/4W
R934	1-249-396-11	CARBON	18	5%	1/6W
R951	1-249-405-11	CARBON	100	5%	1/4W
R953	1-249-419-11	CARBON	1.5K	5%	1/4W
R954	1-249-417-11	CARBON	1K	5%	1/4W
R957-960					
	1-249-396-11	CARBON	18	5%	1/6W
R963	1-249-437-11	CARBON	47K	5%	1/4W
R964	1-249-417-11	CARBON	1K	5%	1/4W
< VARIABLE RESISTOR >					
RV601	1-238-977-11	RES, VAR, CARBON 100K/100K (DYNAMIC BASS SYSTEM LEVEL)			
RV602	1-238-977-11	RES, VAR, CARBON 100K/100K (DYNAMIC BASS FREQUENCY (Hz))			
RV604	1-241-385-11	RES, VAR, CARBON 100K (BALANCE)			
< SWITCH >					
S901	1-554-303-21	SWITCH, TACTILE (DISPLAY)			
S902	1-554-303-21	SWITCH, TACTILE (CURSOR CONTROL ▲)			
S903	1-554-303-21	SWITCH, TACTILE (MEMORY)			
S904	1-554-303-21	SWITCH, TACTILE (DIGITAL SURROUND CONTROL)			
S905	1-554-303-21	SWITCH, TACTILE (DIGITAL SURROUND MODE)			
S906	1-554-303-21	SWITCH, TACTILE (DYNAMIC BASS SYSTEM ON/OFF)			
S907	1-554-303-21	SWITCH, TACTILE (KARAOKE PON) (A67)			
S908	1-554-303-21	SWITCH, TACTILE (CD DIRECT)			
S909	1-554-303-21	SWITCH, TACTILE (CURSOR CONTROL ►)			
S910	1-554-303-21	SWITCH, TACTILE (CURSOR CONTROL ◀)			
S911	1-554-303-21	SWITCH, TACTILE (CURSOR MODE PERSONAL FILE)			
S912	1-554-303-21	SWITCH, TACTILE (CURSOR MODE SELECT 10)			
S913	1-554-303-21	SWITCH, TACTILE (CURSOR MODE EQUALIZER)			

Ref. No.	Part No.	Description	Remark		
S914	1-554-303-21	SWITCH, TACTILE (EQ FLAT)			
S915	1-554-303-21	SWITCH, TACTILE (EFFECT)			
S916	1-554-303-21	SWITCH, TACTILE (DIGITAL SURROUND ON/OFF)			
S917	1-554-303-21	SWITCH, TACTILE (PHONO)			
S918	1-554-303-21	SWITCH, TACTILE (CURSOR CONTROL ▼)			
S919	1-554-303-21	SWITCH, TACTILE (TUNER)			
S920	1-554-303-21	SWITCH, TACTILE (CD)			
S921	1-554-303-21	SWITCH, TACTILE (TAPE)			
S922	1-554-303-21	SWITCH, TACTILE (VIDEO 1)			
S923	1-554-303-21	SWITCH, TACTILE (P. FUNCTION)			
S924	1-554-303-21	SWITCH, TACTILE (VIDEO 2)			

*	A-4360-104-A	PIN JACK BOARD, COMPLETE (D609)			
*	A-4360-105-A	PIN JACK BOARD, COMPLETE (A67)			

< CAPACITOR >					
C101	1-162-288-31	CERAMIC	330PF	10%	50V
C102	1-126-161-11	ELECT	2.2uF	20%	50V
C103	1-162-282-31	CERAMIC	100PF	10%	50V
C104	1-162-219-31	CERAMIC	68PF	5%	50V
C105	1-124-910-11	ELECT	47uF	20%	50V
C106	1-130-480-00	MYLAR	0.0056uF	5%	50V
C107	1-130-473-00	MYLAR	0.0015uF	5%	50V
C108	1-124-464-11	ELECT	0.22uF	20%	50V
C109	1-124-034-51	ELECT	33uF	20%	16V
C110	1-162-286-31	CERAMIC	220PF	10%	50V
C111	1-126-233-11	ELECT	22uF	20%	50V
C112	1-162-286-31	CERAMIC	220PF	10%	50V
C113	1-126-233-11	ELECT	22uF	20%	50V
C114	1-162-286-31	CERAMIC	220PF	10%	50V
C115	1-126-233-11	ELECT	22uF	20%	50V
C119	1-162-286-31	CERAMIC	220PF	10%	50V
C120	1-164-159-11	CERAMIC	0.1uF	50%	50V
C121	1-124-034-51	ELECT	33uF	20%	16V
C151	1-162-288-31	CERAMIC	330PF	10%	50V
C152	1-126-161-11	ELECT	2.2uF	20%	50V
C153	1-162-282-31	CERAMIC	100PF	10%	50V
C154	1-162-219-31	CERAMIC	68PF	5%	50V
C155	1-124-910-11	ELECT	47uF	20%	50V
C156	1-130-480-00	MYLAR	0.0056uF	5%	50V
C157	1-130-473-00	MYLAR	0.0015uF	5%	50V
C158	1-124-464-11	ELECT	0.22uF	20%	50V
C159	1-124-034-51	ELECT	33uF	20%	16V
C160	1-162-286-31	CERAMIC	220PF	10%	50V
C161	1-126-233-11	ELECT	22uF	20%	50V
C162	1-162-286-31	CERAMIC	220PF	10%	50V

Ref. No.	Part No.	Description	Remark		
C163	1-126-233-11	ELECT	22uF	20%	50V
C164	1-162-286-31	CERAMIC	220PF	10%	50V
C165	1-126-233-11	ELECT	22uF	20%	50V
C169	1-162-286-31	CERAMIC	220PF	10%	50V
C170	1-164-159-11	CERAMIC	0.1uF		50V
C171	1-124-034-51	ELECT	33uF	20%	16V
< CONNECTOR >					
* CN101	1-691-183-11	CONNECTOR (BOARD TO BOARD)	13P		
* CN104	1-568-824-11	SOCKET, CONNECTOR	5P		
< IC >					
IC101	8-759-636-73	IC	M5218AL-22		
IC102	8-759-000-48	IC	MC14052BCP		
< JACK >					
J101	1-565-352-11	JACK, PIN 2P	(PHONO)		
J102	1-565-320-11	JACK, PIN 6P	(CD, VIDEO 1)		
< RESISTOR >					
R101	1-249-417-11	CARBON	1K 5%		1/4W
R102	1-249-441-11	CARBON	100K 5%		1/4W
R103	1-249-417-11	CARBON	1K 5%		1/4W
R104	1-249-441-11	CARBON	100K 5%		1/4W
R105	1-249-416-11	CARBON	820 5%		1/4W
R106	1-247-897-11	CARBON	560K 5%		1/4W
R107	1-249-437-11	CARBON	47K 5%		1/4W
R108	1-249-417-11	CARBON	1K 5%		1/4W
R109	1-249-441-11	CARBON	100K 5%		1/4W
R110	1-249-405-11	CARBON	100 5%		1/4W
R112	1-249-423-11	CARBON	3.3K 5%		1/4W
R113	1-249-429-11	CARBON	10K 5%		1/4W
R114	1-249-417-11	CARBON	1K 5%		1/4W
R115	1-247-903-00	CARBON	1M 5%		1/4W
R116	1-249-417-11	CARBON	1K 5%		1/4W
R117	1-247-903-00	CARBON	1M 5%		1/4W
R120	1-249-405-11	CARBON	100 5%		1/4W
R122-124	1-249-417-11	CARBON	1K 5%		1/4W
R125	1-249-405-11	CARBON	100 5%		1/4W
R151	1-249-417-11	CARBON	1K 5%		1/4W
R152	1-249-441-11	CARBON	100K 5%		1/4W
R153	1-249-417-11	CARBON	1K 5%		1/4W
R154	1-249-441-11	CARBON	100K 5%		1/4W
R155	1-249-416-11	CARBON	820 5%		1/4W
R156	1-247-897-11	CARBON	560K 5%		1/4W
R157	1-249-437-11	CARBON	47K 5%		1/4W
R158	1-249-417-11	CARBON	1K 5%		1/4W

Ref. No.	Part No.	Description	Remark		
R159	1-249-441-11	CARBON	100K 5%		1/4W
R160	1-249-405-11	CARBON	100 5%		1/4W
R162	1-249-423-11	CARBON	3.3K 5%		1/4W
R163	1-249-429-11	CARBON	10K 5%		1/4W
R164	1-249-417-11	CARBON	1K 5%		1/4W
R165	1-247-903-00	CARBON	1M 5%		1/4W
R166	1-249-417-11	CARBON	1K 5%		1/4W
R167	1-247-903-00	CARBON	1M 5%		1/4W
R170	1-249-405-11	CARBON	100 5%		1/4W
R175	1-249-405-11	CARBON	100 5%		1/4W

*	1-647-203-11	PS BOARD	*****		
< CAPACITOR >					
C805	1-124-887-00	ELECT	3300uF	20%	16V
C806	1-124-887-00	ELECT	3300uF	20%	16V
C811	1-101-006-00	CERAMIC (A67)	0.047uF		50V
C811	1-136-165-00	FILM (D609)	0.1uF	5%	50V
C812	1-101-006-00	CERAMIC (A67)	0.047uF		50V
C812	1-136-165-00	FILM (D609)	0.1uF	5%	50V
C813	1-161-021-11	CERAMIC	0.047uF	10%	25V
C814	1-161-021-11	CERAMIC	0.047uF	10%	25V
△C815	1-102-394-11	CERAMIC	0.01uF		250V
C817	1-126-162-11	ELECT	3.3uF	20%	50V
C820	1-124-910-11	ELECT	47uF	20%	50V
C821	1-124-910-11	ELECT	47uF	20%	50V
C822	1-124-920-11	ELECT	330uF	20%	63V
< DIODE >					
D801	8-719-302-38	DIODE	RBV-602-01		
D806-809	8-719-200-77	DIODE	10E2N		
D811	8-719-987-63	DIODE	1N4148M		
D812	8-719-987-63	DIODE	1N4148M		
D820	8-719-200-77	DIODE	10E2N		
D821	8-719-200-77	DIODE	10E2N		
< IC LINK >					
△ICP801	1-532-843-21	LINK, IC (PRF2500)	(2.5A)		
△ICP802	1-532-843-21	LINK, IC (PRF2500)	(2.5A)		
< RESISTOR >					
R803	1-249-428-11	CARBON	8.2K 5%		1/4W
R804	1-249-428-11	CARBON	8.2K 5%		1/4W

The components identified by mark △ or dotted line with mark. △ are critical for safety. Replace only with part number specified.

PT **S. PANEL** **V1**

Ref. No.	Part No.	Description	Remark
*	1-647-204-11	PT BOARD *****	

*	A-4360-101-A	S. PANEL BOARD, COMPLETE *****	
< CAPACITOR >			
C901	1-124-473-11	ELECT 1000uF	20% 10V
C903	1-124-994-11	ELECT 100uF	20% 10V
C904	1-164-159-11	CERAMIC 0.1uF	50V
C906	1-161-379-00	CERAMIC 0.01uF	20% 25V
C907	1-136-159-00	FILM 0.033uF	5% 50V
C908	1-164-159-11	CERAMIC 0.1uF	50V
C923	1-126-059-11	ELECT 10uF	20% 50V
C925	1-126-059-11	ELECT 10uF	20% 50V
C938	1-126-101-11	ELECT 100uF	20% 16V
< CONNECTOR >			
* CN602	1-568-828-11	SOCKET, CONNECTOR 9P	
* CN606	1-568-828-11	SOCKET, CONNECTOR 9P	
* CN901	1-568-834-11	SOCKET, CONNECTOR 15P	
< DIODE >			
D901	8-719-000-81	DIODE UZL-7L3	
D902	8-719-987-63	DIODE 1N4148M	
D903	8-719-200-82	DIODE 11ES2	
D904	8-719-200-82	DIODE 11ES2	
D905	8-719-987-63	DIODE 1N4148M	
D908	8-719-987-63	DIODE 1N4148M	
D909	8-719-987-63	DIODE 1N4148M	
D910	8-719-200-82	DIODE 11ES2	
D928	8-719-987-63	DIODE 1N4148M	
D929	8-719-000-60	DIODE UZL-6M2	
D980	8-719-200-82	DIODE 11ES2	
D981	8-719-987-63	DIODE 1N4148M	
< IC >			
IC602	8-759-801-01	IC LC4966	
IC902	8-759-635-63	IC M51943BSL	
< COIL >			
L901	1-408-080-00	INDUCTOR 100uH	
L921	1-408-121-00	INDUCTOR 22uH	
L922	1-408-121-00	INDUCTOR 22uH	
< TRANSISTOR >			
Q661	8-729-900-63	TRANSISTOR DTA124ES	

Ref. No.	Part No.	Description	Remark
Q662	8-729-900-36	TRANSISTOR DTC124ES	
Q901	8-729-620-05	TRANSISTOR 2SC2603-EF	
Q902	8-729-620-05	TRANSISTOR 2SC2603-EF	
< RESISTOR >			
R623	1-249-441-11	CARBON 100K 5%	1/4W
R624	1-249-435-11	CARBON 33K 5%	1/4W
R625	1-249-426-11	CARBON 5.6K 5%	1/4W
R661	1-249-433-11	CARBON 22K 5%	1/4W
R674	1-249-435-11	CARBON 33K 5%	1/4W
R675	1-249-426-11	CARBON 5.6K 5%	1/4W
R901	1-249-429-11	CARBON 10K 5%	1/4W
R902-904			
	1-249-433-11	CARBON 22K 5%	1/4W
R905	1-249-441-11	CARBON 100K 5%	1/4W
R906	1-249-417-11	CARBON 1K 5%	1/4W
R907	1-249-441-11	CARBON 100K 5%	1/4W
R941-947			
	1-249-417-11	CARBON 1K 5%	1/4W
R952	1-249-393-11	CARBON 10 5%	1/4W
R961	1-249-429-11	CARBON 10K 5%	1/4W
R962	1-249-429-11	CARBON 10K 5%	1/4W

*	1-647-225-11	V1 BOARD *****	
< CAPACITOR >			
C202	1-124-471-00	ELECT 1000uF	20% 6.3V
C203	1-126-059-11	ELECT 10uF	20% 50V
C204	1-124-471-00	ELECT 1000uF	20% 6.3V
C205	1-162-306-11	CERAMIC 0.01uF	20% 16V
C206	1-124-997-11	ELECT 470uF	20% 10V
< CONNECTOR >			
* CN201	1-691-176-11	CONNECTOR (BOARD TO BOARD) 6P	
< IC >			
IC201	8-759-514-76	IC MM1031XS	
< JACK >			
J104	1-565-351-61	JACK, PIN 3P (MONITOR, VIDEO 1)	
< COIL >			
L201	1-408-080-00	INDUCTOR 100uH	
< TRANSISTOR >			
Q201	8-729-119-77	TRANSISTOR 2SA1175-FEK	
Q202	8-729-900-63	TRANSISTOR DTA124ES	

Ref. No.	Part No.	Description	Remark
Q203	8-729-119-77	TRANSISTOR 2SA1175-FEK	
Q204	8-729-900-80	TRANSISTOR DTC114ES	
Q205	8-729-620-05	TRANSISTOR 2SC2603-EF	
< RESISTOR >			
R202	1-249-403-11	CARBON 68 5% 1/4W	
R203	1-249-429-11	CARBON 10K 5% 1/4W	
R204	1-247-804-11	CARBON 75 5% 1/4W	
R205	1-249-403-11	CARBON 68 5% 1/4W	
R206	1-249-429-11	CARBON 10K 5% 1/4W	
R207-209			
	1-249-408-11	CARBON 180 5% 1/4W	
R210	1-249-433-11	CARBON 22K 5% 1/4W	
R211	1-249-426-11	CARBON 5.6K 5% 1/4W	
R213	1-249-408-11	CARBON 180 5% 1/4W	
R214	1-249-417-11	CARBON 1K 5% 1/4W	

*	1-647-226-11	V2 BOARD	

< CAPACITOR >			
C116	1-162-286-31	CERAMIC 220PF 10% 50V	
C117	1-126-233-11	ELECT 22uF 20% 50V	
C166	1-162-286-31	CERAMIC 220PF 10% 50V	
C167	1-126-233-11	ELECT 22uF 20% 50V	
C201	1-126-059-11	ELECT 10uF 20% 50V	
< CONNECTOR >			
* CN103	1-568-824-11	SOCKET, CONNECTOR 5P	
< JACK >			
J103	1-580-174-41	JACK, PIN (3P FRONT) (VIDEO 3 INPUT)	
< RESISTOR >			
R118	1-249-413-11	CARBON 470 5% 1/4W	
R119	1-247-903-00	CARBON 1M 5% 1/4W	
R168	1-249-413-11	CARBON 470 5% 1/4W	
R169	1-247-903-00	CARBON 1M 5% 1/4W	
R201	1-247-804-11	CARBON 75 5% 1/4W	

*	A-4360-102-A	VR BOARD, COMPLETE	

< CAPACITOR >			
C627	1-126-300-11	ELECT 0.47uF 20% 50V	
C628	1-164-159-11	CERAMIC 0.1uF 50V	
C677	1-126-300-11	ELECT 0.47uF 20% 50V	
C917	1-124-472-11	ELECT 470uF 20% 10V	
C935	1-124-443-00	ELECT 100uF 20% 10V	

Ref. No.	Part No.	Description	Remark
< CONNECTOR >			
* CN605	1-564-506-11	PLUG, CONNECTOR 3P	
* CN607	1-568-828-11	SOCKET, CONNECTOR 9P	
< DIODE >			
D681-683			
	8-719-815-85	DIODE 1S1585	
D971	8-719-010-32	DIODE UZ-4.7BSA	
D972	8-719-200-82	DIODE 11ES2	
D973	8-719-200-82	DIODE 11ES2	
< IC >			
IC904	8-759-820-62	IC LB1639	
< TRANSISTOR >			
Q605	8-729-900-63	TRANSISTOR DTA124ES	
Q621	8-729-141-26	TRANSISTOR 2SC3622A-LK	
Q671	8-729-141-26	TRANSISTOR 2SC3622A-LK	
Q681	8-729-900-61	TRANSISTOR DTA114ES	
< RESISTOR >			
R620	1-249-425-11	CARBON 4.7K 5% 1/4W	
R621	1-249-417-11	CARBON 1K 5% 1/4W	
R670	1-249-425-11	CARBON 4.7K 5% 1/4W	
R671	1-249-417-11	CARBON 1K 5% 1/4W	
R682	1-249-425-11	CARBON 4.7K 5% 1/4W	
R974	1-249-405-11	CARBON 100 5% 1/4W	
R975	1-249-433-11	CARBON 22K 5% 1/4W	
R976	1-249-433-11	CARBON 22K 5% 1/4W	
R977	1-249-412-11	CARBON 390 5% 1/4W	
< VARIABLE RESISTOR >			
RV603	1-223-404-11	RES, VAR, CARBON 100K/100K/10K (VOLUME)	

Ref. No.	Part No.	Description	Remark
MISCELLANEOUS			

17	1-575-905-31	WIRE, FLAT TYPE (9 CORE)	
64	1-751-209-11	WIRE, FLAT TYPE (9 CORE)	
△65	1-575-654-11	CORD, POWER (EA, MY, SP, D609)	
△66	1-575-656-11	CORD, POWER (E)	
△67	1-751-355-11	CORD, POWER (AUS)	
69	1-690-094-11	WIRE, FLAT TYPE (15 CORE)	
70	1-690-992-11	WIRE, FLAT TYPE (7 CORE)	
71	1-690-066-31	WIRE, FLAT TYPE (5 CORE)	
△F1	1-532-259-00	FUSE, TIME-LAG (T1. 6A) (A67)	
△F1	1-532-286-00	FUSE, TIME-LAG (T2. 5A) (D609)	
△F2	1-532-259-00	FUSE, TIME-LAG (T1. 6A) (A67)	
△F801	1-532-203-00	FUSE, TIME-LAG (T2A)	
△F802	1-532-203-00	FUSE, TIME-LAG (T2A)	
△T1	1-423-529-11	TRANSFORMER, POWER (D609)	
△T1	1-423-530-11	TRANSFORMER, POWER (E, AUS, EA, MY)	
△T1	1-423-603-11	TRANSFORMER, POWER (SP)	

HARDWARE LIST

#1	7-621-849-00	SCREW (BV/RING)
#2	7-682-560-04	SCREW +BVTT 4X6 (S)
#3	7-685-650-79	SCREW +BVTP 3X16 TYPE2
#4	7-685-871-01	SCREW +BVTT 3X6 (S)
#5	7-682-548-04	SCREW +BVTT 3X8 (S)
#6	7-685-645-79	SCREW +BVTP 3X6 TYPE2
#7	7-685-646-79	SCREW +BVTP 3X8 TYPE2 N-S

The components identified by mark △ or dotted line with mark. △ are critical for safety. Replace only with part number specified.