

TA-E1

SERVICE MANUAL

*US Model
Canadian Model
AEP Model
UK Model
E Model
Australian Model*



SPECIFICATIONS

Audio section

Harmonic distortion

Less than 0.005%
(at 2 V, THD)

Frequency response

5 Hz ~ 300 kHz
(0 ~ -1 dB)

Signal-to-noise ratio

More than 115 dB
(Input shorted, A-Fil)

Inputs

Input	Sensitivity	Impedance
LINE 1	250 mV	20 k Ω
LINE 2	250 mV	20 k Ω
CD	250 mV	20 k Ω
SACD	250 mV	20 k Ω
BALANCED LINE	250 mV	40 k Ω
DAT/TAPE 1	250 mV	20 k Ω
MD/TAPE 2	250 mV	20 k Ω

Outputs

Output	Voltage	Impedance
PRE OUT	2 V	47 Ω
BALANCED OUT	2 V	220 Ω

General

Power requirements

USA and Canadian models :
120 V AC, 60Hz
European models :
230 V AC, 50/60Hz

Power consumption

18 W

Dimensions 430 × 108 × 445 mm
(17 × 4¹/₄ × 17¹/₂ in.)
including projecting parts and controls

Mass (Approx.)

21.5 kg (47 lb. 06 oz.)

Supplied accessories

Check that you received the following items with the unit:

- Audio cord (1)
- AC power cord (1)
- AC power plug adapter (3 to 2 prong polarized type) (1) (USA/Canada only)

Design and specifications are subject to change without notice.

STEREO PRE AMPLIFIER

SONY®



SAFETY CHECK-OUT

After correcting the original service problem, perform the following safety checks before releasing the set to the customer: Check the antenna terminals, metal trim, "metallized" knobs, screws, and all other exposed metal parts for AC leakage. Check leakage as described below.

LEAKAGE

The AC leakage from any exposed metal part to earth Ground and from all exposed metal parts to any exposed metal part having a return to chassis, must not exceed 0.5 mA (500 microamperes). Leakage current can be measured by any one of three methods.

1. A commercial leakage tester, such as the Simpson 229 or RCA WT-540A. Follow the manufacturers' instructions to use these instruments.
2. A battery-operated AC milliammeter. The Data Precision 245 digital multimeter is suitable for this job.
3. Measuring the voltage drop across a resistor by means of a VOM or battery-operated AC voltmeter. The "limit" indication is 0.75 V, so analog meters must have an accurate low-voltage scale. The Simpson 250 and Sanwa SH-63Trd are examples of a passive VOM that is suitable. Nearly all battery operated digital multimeters that have a 2V AC range are suitable. (See Fig. A)

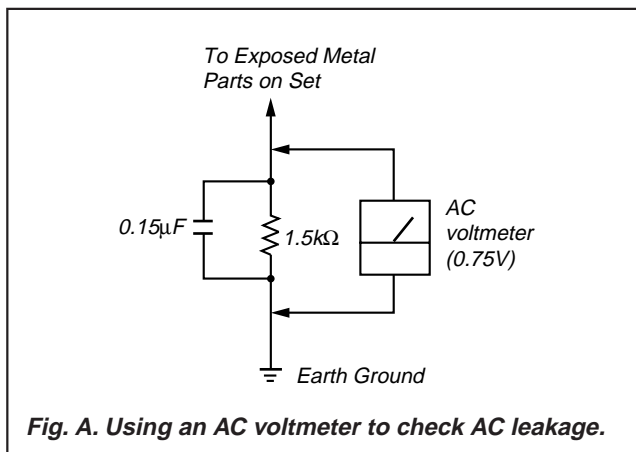

SAFETY-RELATED COMPONENT WARNING !!

COMPONENTS IDENTIFIED BY MARK \triangle OR DOTTED LINE WITH MARK \triangle ON THE SCHEMATIC DIAGRAMS AND IN THE PARTS LIST ARE CRITICAL TO SAFE OPERATION. REPLACE THESE COMPONENTS WITH SONY PARTS WHOSE PART NUMBERS APPEAR AS SHOWN IN THIS MANUAL OR IN SUPPLEMENTS PUBLISHED BY SONY.

ATTENTION AU COMPOSANT AYANT RAPPORT À LA SÉCURITÉ!!

LES COMPOSANTS IDENTIFIÉS PAR UNE MARQUE \triangle SUR LES DIAGRAMMES SCHÉMATIQUES ET LA LISTE DES PIÈCES SONT CRITIQUES POUR LA SÉCURITÉ DE FONCTIONNEMENT. NE REMPLACER CES COMPOSANTS QUE PAR DES PIÈCES SONY DONT LES NUMÉROS SONT DONNÉS DANS CE MANUEL OU DANS LES SUPPLÉMENTS PUBLIÉS PAR SONY.

TABLE OF CONTENTS

1. GENERAL	3
2. ELECTRICAL ADJUSTMENT	5
3. DIAGRAMS	
3-1. Circuit Boards Location	5
3-2. Schematic Diagram – Main Section (1/3) –	6
3-3. Schematic Diagram – Main Section (2/3) –	7
3-4. Schematic Diagram – Main Section (3/3) –	8
3-5. Printed Wiring Board – Main Section –	9
3-6. Schematic Diagram – Power Section –	10
3-7. Printed Wiring Board – Power Section –	11
4. EXPLODED VIEWS	
4-1. Top Plate and Back Panel Section	12
4-2. Front Panel Section	12
4-3. Bottom Plate Section	13
5. ELECTRICAL PARTS LIST	14

MODEL IDENTIFICATION — BACK PANEL —

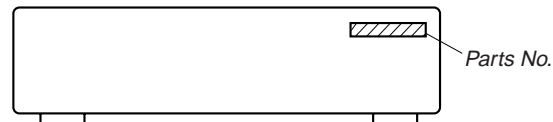

PARTS No.	MODEL
4-214-526-1□	US , CND
4-214-526-2□	AEP, UK, E, AUS

- Abbreviation
CND : Canadian model
AUS : Australian model

Front Panel Parts Description

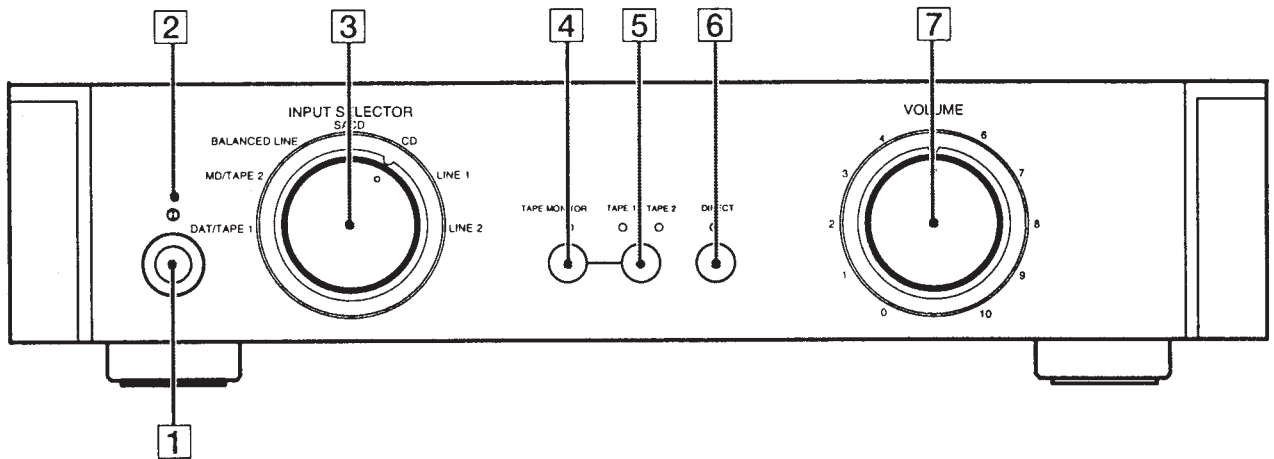

1 ① (power) switch

Press to turn the preamplifier on and off.

- Before you turn on the preamplifier, make sure that you have turned the VOLUME control to the leftmost position to avoid damaging your speakers.

2 Power indicator

Lights red for 12 seconds when preamplifier is turned on, and then lights green.

3 INPUT SELECTOR control

Turn to select the component you want to use.

To select	Turn to light
DAT deck, tape deck 1	DAT/TAPE 1
MD deck	MD/TAPE 2
BALANCED LINE	BALANCED LINE
SACD player	SACD
CD player	CD
LINE 1	LINE 1
LINE 2	LINE 2

After selecting the component, turn on the component you selected and play the program source.

4 TAPE MONITOR button

Press to turn the tape monitor on and off. The indicator lights when the tape monitor is on and goes out when the tape monitor is turned off.

5 TAPE MONITOR input select button

When the TAPE MONITOR (**4**) is on, press to select the input from the TAPE 1 or TAPE 2 input jacks. The indicator lights to show which input is selected.

6 DIRECT button

Press to select the input connected to the DIRECT input jacks. The indicator lights, and the source component connected to the DIRECT input jacks takes priority over the source component selected with the INPUT SELECTOR control (**3**).

Press the DIRECT button again to return to the source selected with the INPUT SELECTOR control.

7 VOLUME control

After turning on the component you selected, turn to adjust the volume.

Rear Panel Parts Description

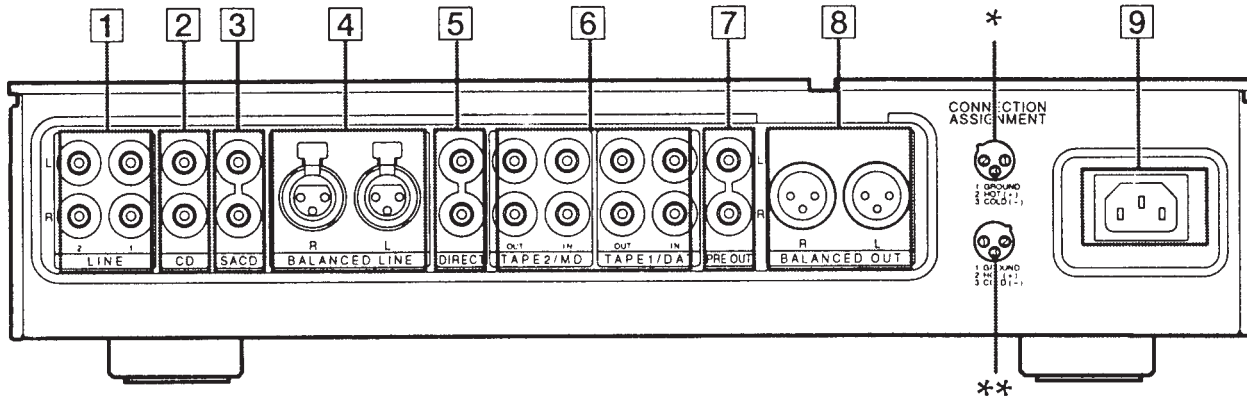

1 LINE 1/2 input jacks

Connect to the analog audio output jacks of your audio components.

2 CD input jacks

Connect to the audio output jacks of your CD player.

3 SACD input jacks

Connect to the audio output jacks of your SACD player.

4 BALANCED LINE input jacks

Connect to the BALANCED OUT jacks of an audio component that is capable of balanced output (XLR type).

5 DIRECT input jacks

Connect to the analog audio output jacks of your audio components. When a component is connected to these jacks, pressing the DIRECT button to select the component causes the indicator on the front panel to light.

When the DIRECT button is pressed, the component connected to these jacks takes priority over the component selected with the INPUT SELECTOR control.

6 TAPE 2/MD, TAPE 1/DAT IN/OUT jacks

Use to connect the input and output jacks of your DAT deck, MD deck, tape player (etc.).

7 PRE OUT jacks

Connect to your power amplifier(s).

8 BALANCED OUT jacks

Connect to your power amplifier(s) using balanced cords.

* : Displays the pin polarity of the BALANCED LINE jacks.

** : Displays the pin polarity of the BALANCED OUT jacks.

9 AC IN terminal

Connect the supplied power cord to the AC IN terminal and then to the wall outlet to supply power to the unit.

SECTION 2 ELECTRICAL ADJUSTMENTS

IDLING ADJUSTMENT AND OFFSET VOLTAGE CHECK

- Perform this adjustment after replacing CP103 and CP104.
- Perform this adjustment more than 10 minutes after supplying the power.

Connection:

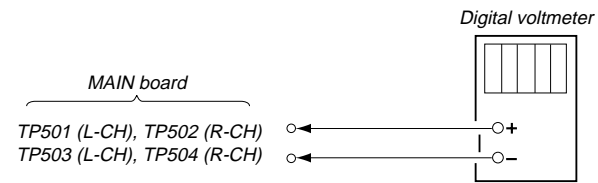

Procedure:

1. Connect the digital voltmeter as shown above.
2. Adjust RV501 (L-CH) and RV502 (R-CH) of the MAIN board so that the digital voltmeter reads $50\text{ mV} \pm 5\text{ mV}$. (Idling adjustment)

	Measuring Point	Adjusting Point	Adjusting Value
L-CH	TP501 to TP503	RV501	$50\text{ mV} \pm 5\text{ mV}$
R-CH	TP502 to TP504	RV502	$50\text{ mV} \pm 5\text{ mV}$

3. Measure the voltage of both terminals of R221 (L-CH) and R222 (R-CH) of the MAIN board, and check that the voltage is within 2 mV. (Offset voltage check)

	Measuring Point	Specified Value
L-CH	Both terminals of R221	Within 2 mV
R-CH	Both terminals of R222	Within 2 mV

BALANCE OUTPUT LEVEL ADJUSTMENT

- Perform this adjustment when replacing CP102.
- Perform this adjustment after the idling adjustment

Connection:

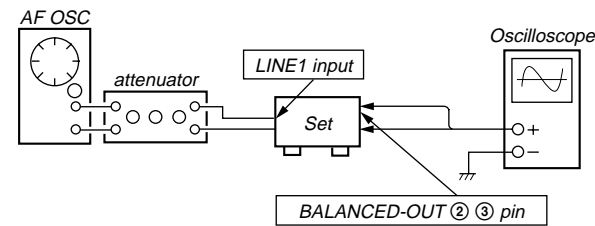

Procedure:

1. Connect as shown above.
2. Rotate the **INPUT SELECTOR** knob, and set the input source to **LINE 1**.
3. Set the input level so that the oscilloscope waveform level becomes approx 3 V.
4. Adjust RV401 (L-CH) and RV402 (R-CH) so that the two waveform levels on the oscilloscope become equal and their phases are reversed.

	Adjusting Point	Adjusting Value
L-CH	Pin ② (CH1) and Pin ③ (CH2) of CN203	RV401
R-CH	Pin ② (CH1) and Pin ③ (CH2) of CN203	RV401

Adjusting Value:

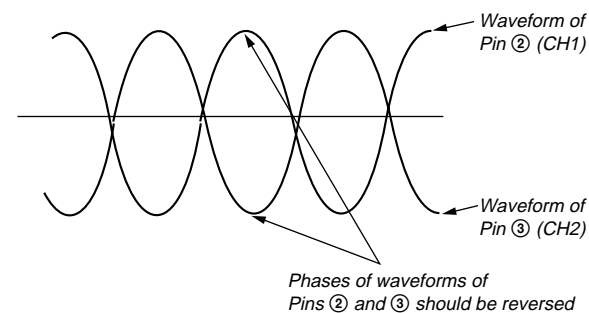

Adjustment Location:

[MAIN board] (Component Side)

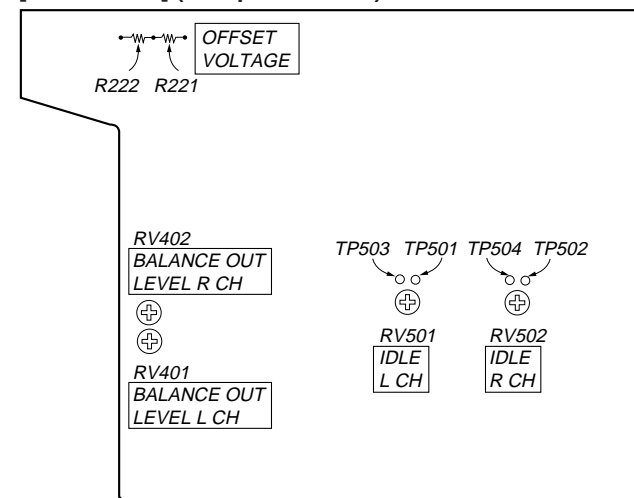

SECTION 3 DIAGRAMS

3-1. CIRCUIT BOARDS LOCATION

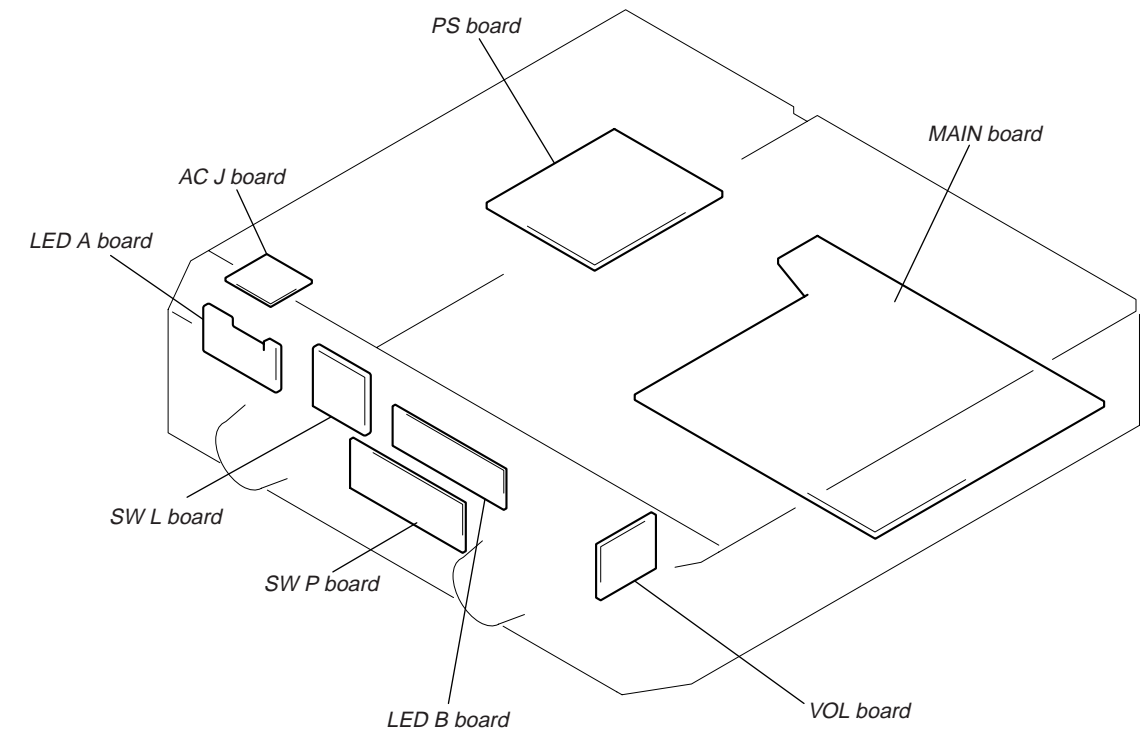

THIS NOTE IS COMMON FOR PRINTED WIRING BOARDS AND SCHEMATIC DIAGRAMS.
(In addition to this, the necessary note is printed in each block.)

For schematic diagrams.

Note:

- All capacitors are in μF unless otherwise noted. pF: μF 50 WV or less are not indicated except for electrolytics and tantalums.
- All resistors are in Ω and $1/4\text{ W}$ or less unless otherwise specified.
- % : indicates tolerance.
- : nonflammable resistor.
- : fusible resistor.
- : panel designation.

Note:

The components identified by mark Δ or dotted line with mark Δ are critical for safety. Replace only with part number specified.

Note:

Les composants identifiés par une marque Δ sont critiques pour la sécurité. Ne les remplacer que par une pièce portant le numéro spécifié.

- **B+** : B+ Line.
- **B-** : B- Line.
- : adjustment for repair.
- Voltages and waveforms are dc with respect to ground in playback mode.
- Voltages are taken with a VOM (Input impedance $10\text{ M}\Omega$). Voltage variations may be noted due to normal production tolerances.
- Signal path.
- : TUNER

For printed wiring boards.

Note:



- : parts extracted from the component side.
- : Through hole.
- : Pattern from the side which enables seeing. (The other layers' patterns are not indicated.)

Caution:

Pattern face side: Parts on the pattern face side seen from the (Side B) pattern face are indicated.
Parts face side: Parts on the parts face side seen from the (Side A) parts face are indicated.

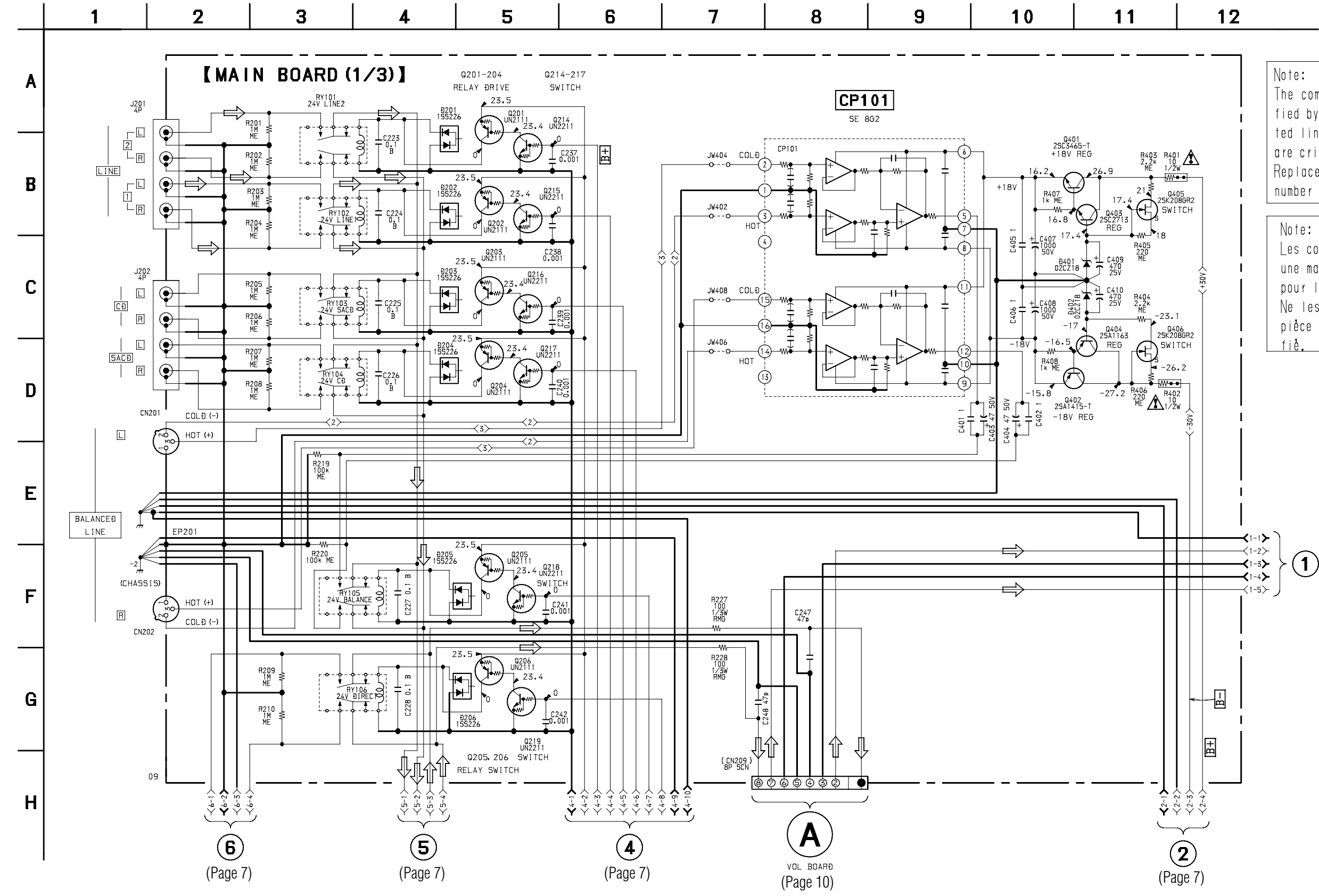
3-2. SCHEMATIC DIAGRAM – MAIN SECTION (1/3) –
• Refer to page 9 for Printed Wiring Board.



Note:
The components identified by mark  or dotted line with mark  are critical for safety. Replace only with part number specified.

Note:
Les composants identifiés par une marque  sont critiques pour la sécurité. Ne les remplacer que par une pièce portant le numéro spécifié.

① (Page 8)

⑥ (Page 7)

⑤ (Page 7)

④ (Page 7)

Ⓐ VOL BOARD (Page 10)

② (Page 7)

3-4. SCHEMATIC DIAGRAM – MAIN SECTION (3/3) –

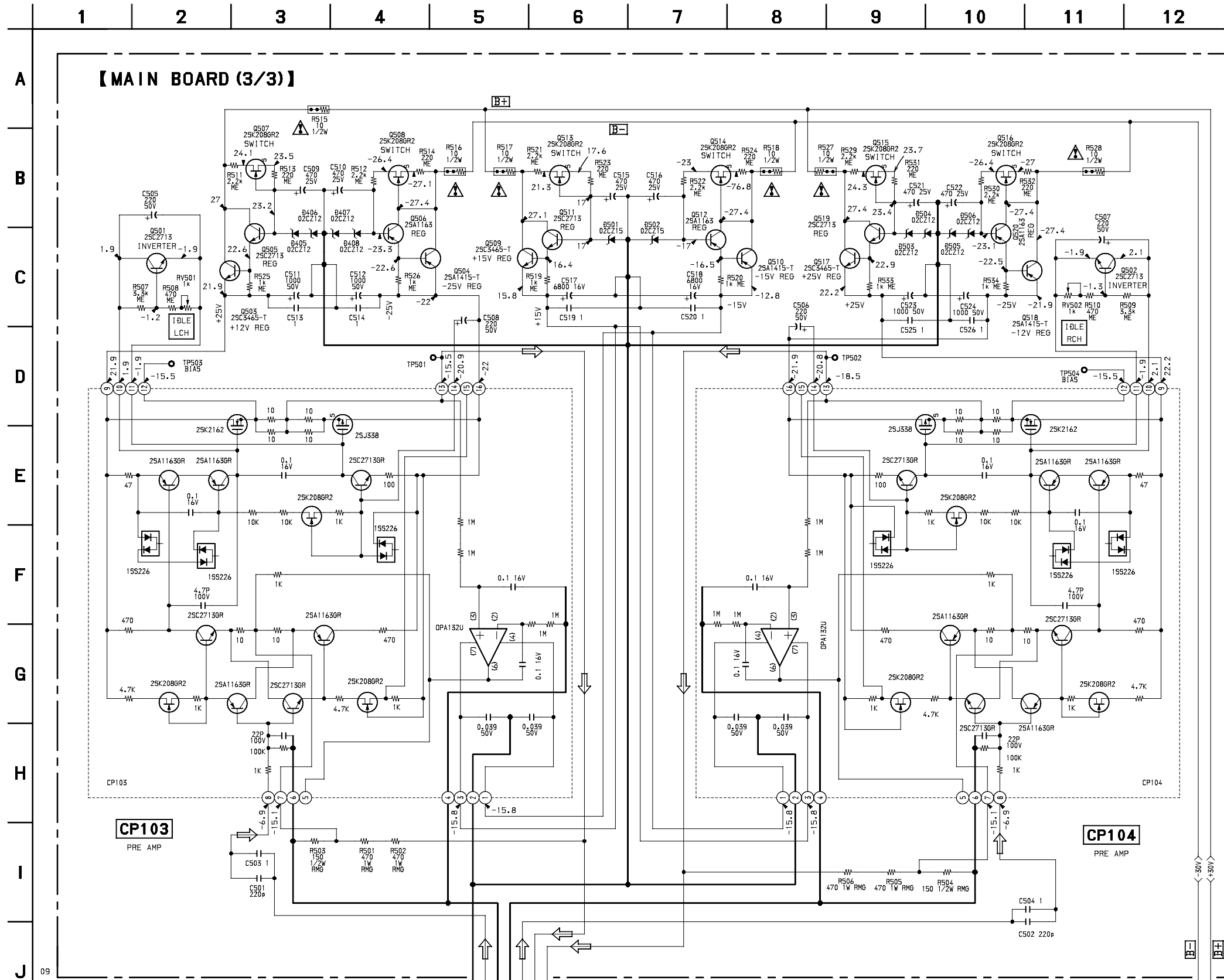

Note:
The components identified by mark **▲** or dotted line with mark **▲** are critical for safety. Replace only with part number specified.

Note:
Les composants identifiés par une marque **▲** sont critiques pour la sécurité. Ne les remplacer que par une pièce portant le numéro spécifié.

① ③
(Page 6) (Page 7)

⑦
(Page 7)

3-5. PRINTED WIRING BOARD – MAIN SECTION –

• Refer to page 5 for Circuit Boards Location.

【MAIN BOARD】

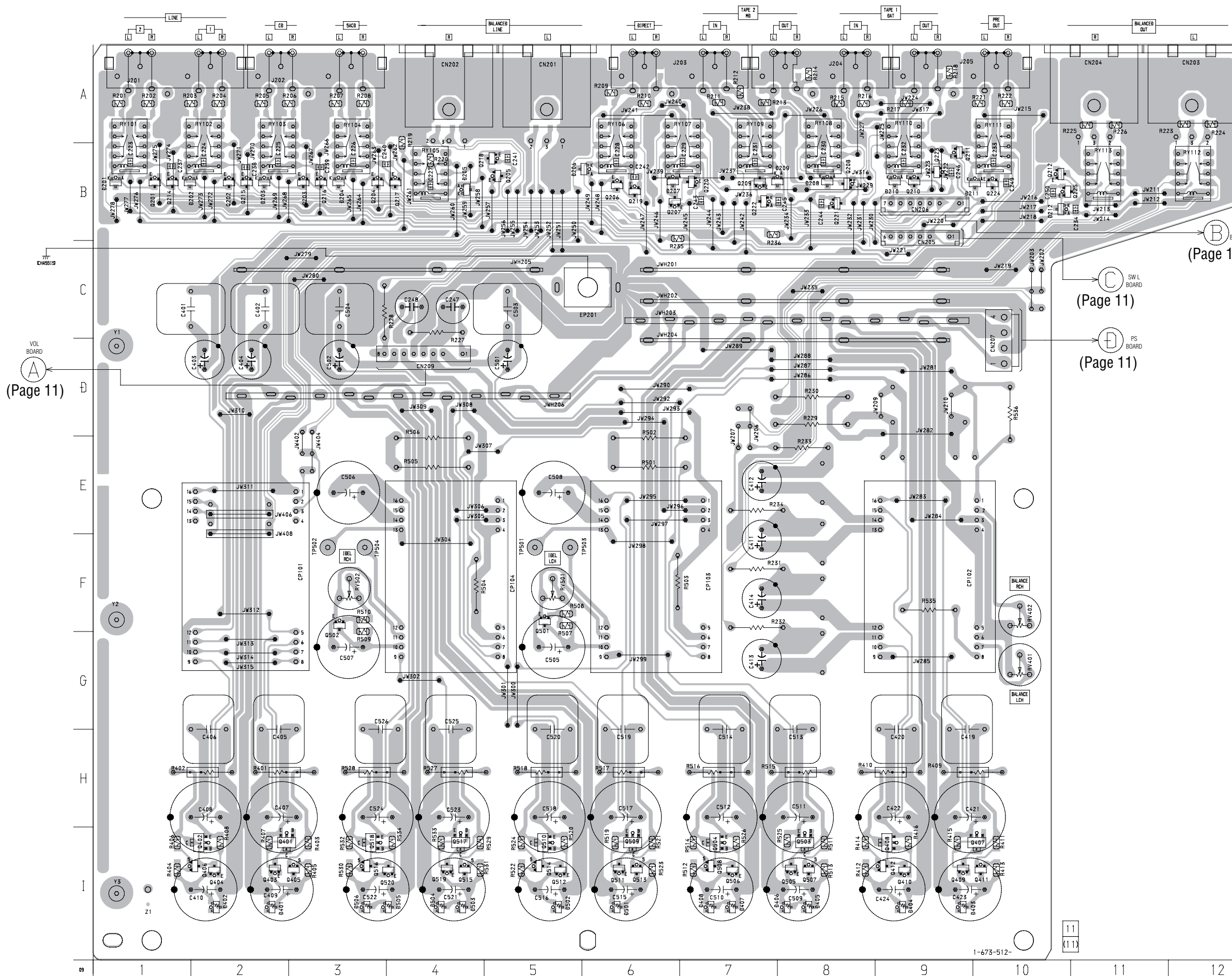

(Page 11)

(Page 11)

(Page 11)

(Page 11)

Ref. No	Location
D201	B-1
D202	B-1
D203	B-2
D204	B-3
D205	B-4
D206	B-5
D207	B-6
D208	B-8
D209	B-8
D210	B-7
D211	B-10
D212	B-10
D401	I-2
D402	I-2
D403	I-9
D404	I-9
D405	I-8
D406	I-8
D407	I-7
D408	I-7
D501	I-6
D502	I-5
D503	I-4
D504	I-4
D505	I-3
D506	I-4
Q201	B-1
Q202	B-2
Q203	B-3
Q204	B-3
Q205	B-5
Q206	B-6
Q207	B-6
Q208	B-8
Q209	B-7
Q210	B-7
Q211	B-7
Q212	B-10
Q214	B-1
Q215	B-2
Q216	B-3
Q217	B-4
Q218	B-5
Q219	B-6
Q220	B-7
Q221	B-8
Q222	B-7
Q223	B-7
Q224	B-10
Q225	B-11
Q401	I-2
Q402	I-2
Q403	I-2
Q404	I-2
Q405	I-3
Q406	I-2
Q407	I-10
Q408	I-9
Q409	I-9
Q410	I-9
Q411	I-10
Q412	I-9
Q501	F-5
Q502	F-3
Q503	I-8
Q504	I-7
Q505	I-8
Q506	I-7
Q507	I-8
Q508	I-7
Q509	I-6
Q510	I-5
Q511	I-6
Q512	I-5
Q513	I-6
Q514	I-5
Q515	I-4
Q516	I-3
Q517	I-4
Q518	I-3
Q519	I-4
Q520	I-4

3-6. SCHEMATIC DIAGRAM - POWER SECTION -

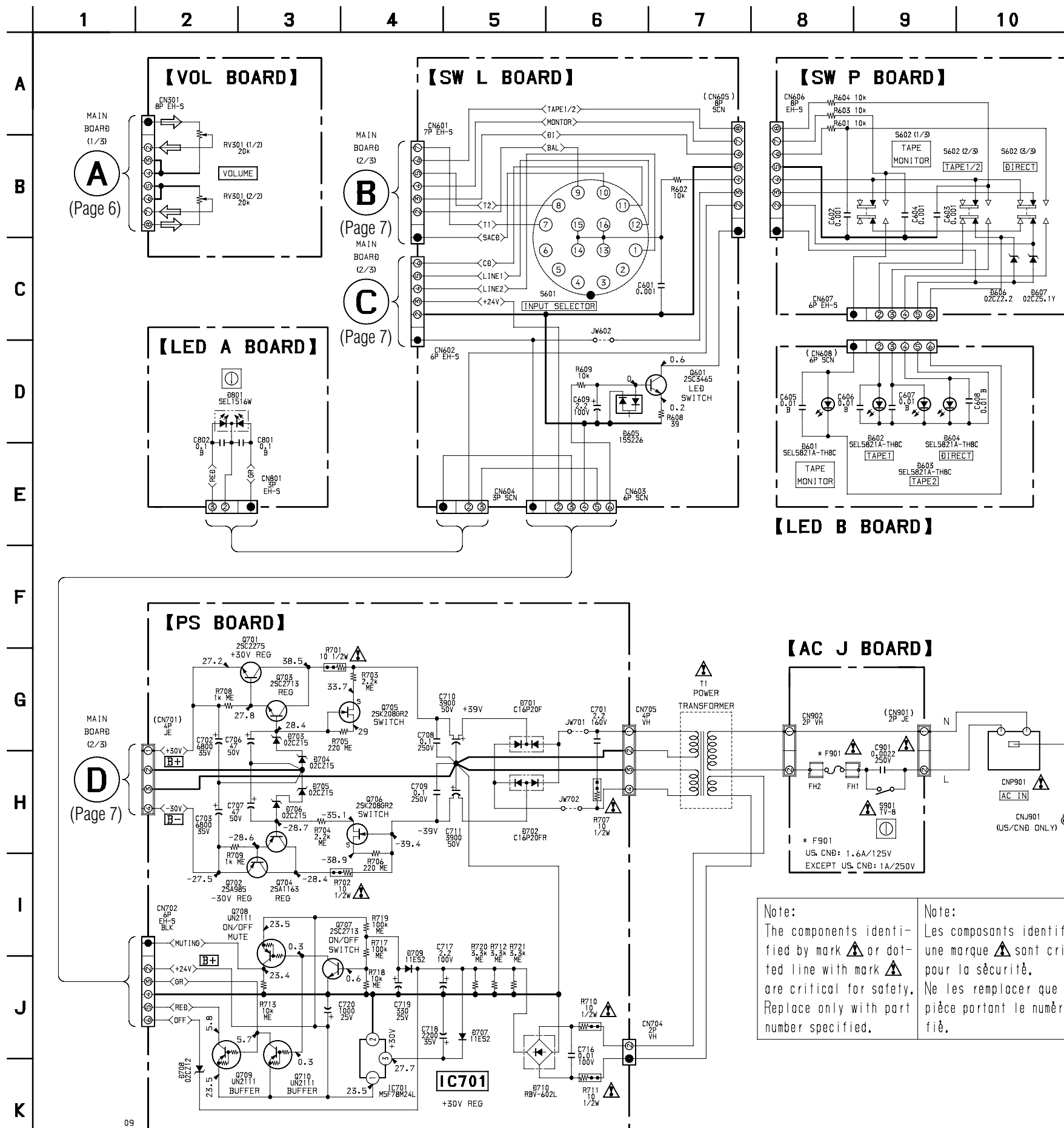

3-7. PRINTED WIRING BOARD – POWER SECTION –
 • Refer to page 5 for Circuit Boards Location.

【VOL BOARD】

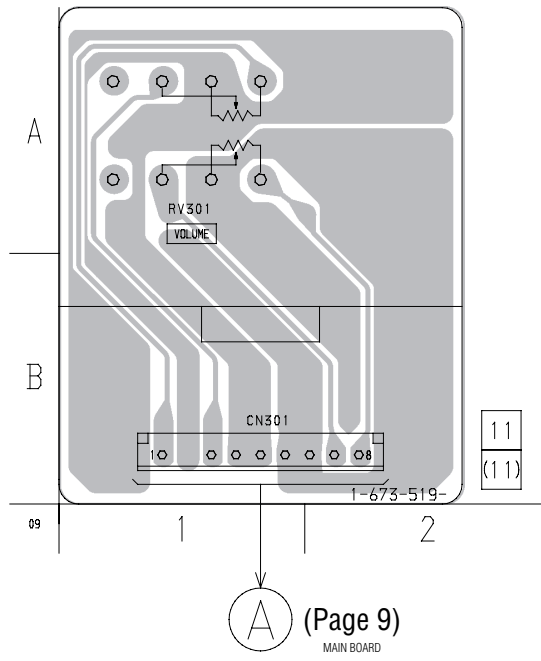

【LED A BOARD】

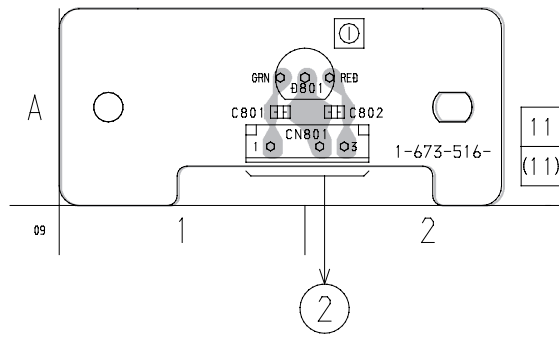

【SW L BOARD】

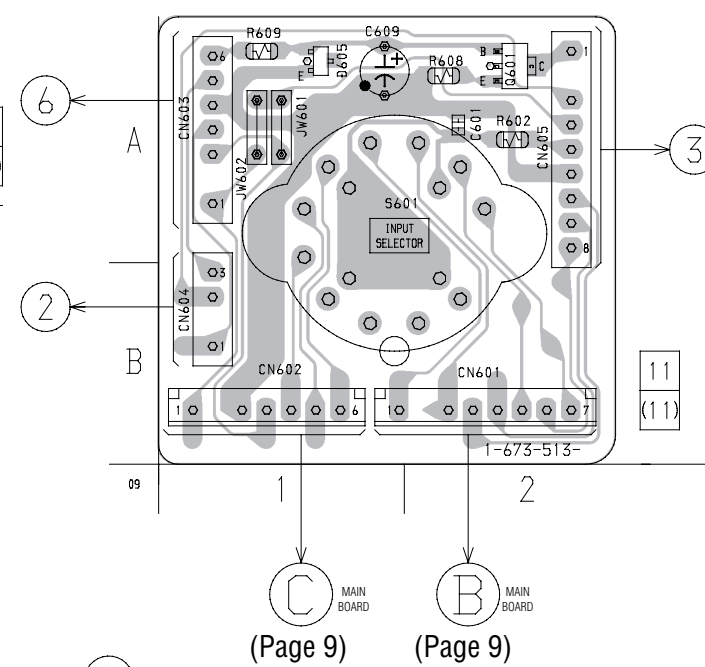

【SW P BOARD】

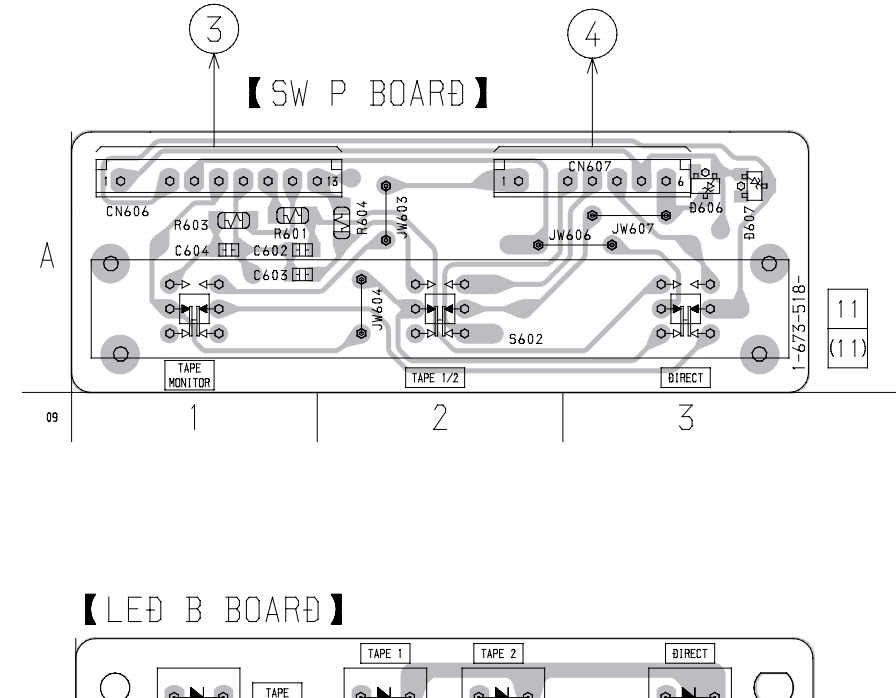

【LED B BOARD】

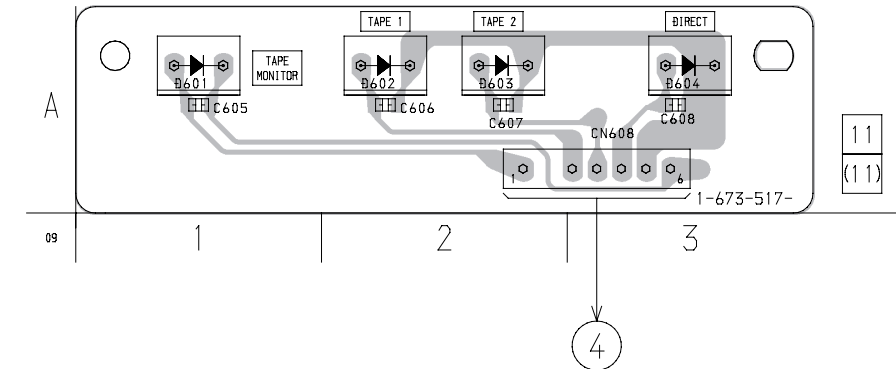

【PS BOARD】

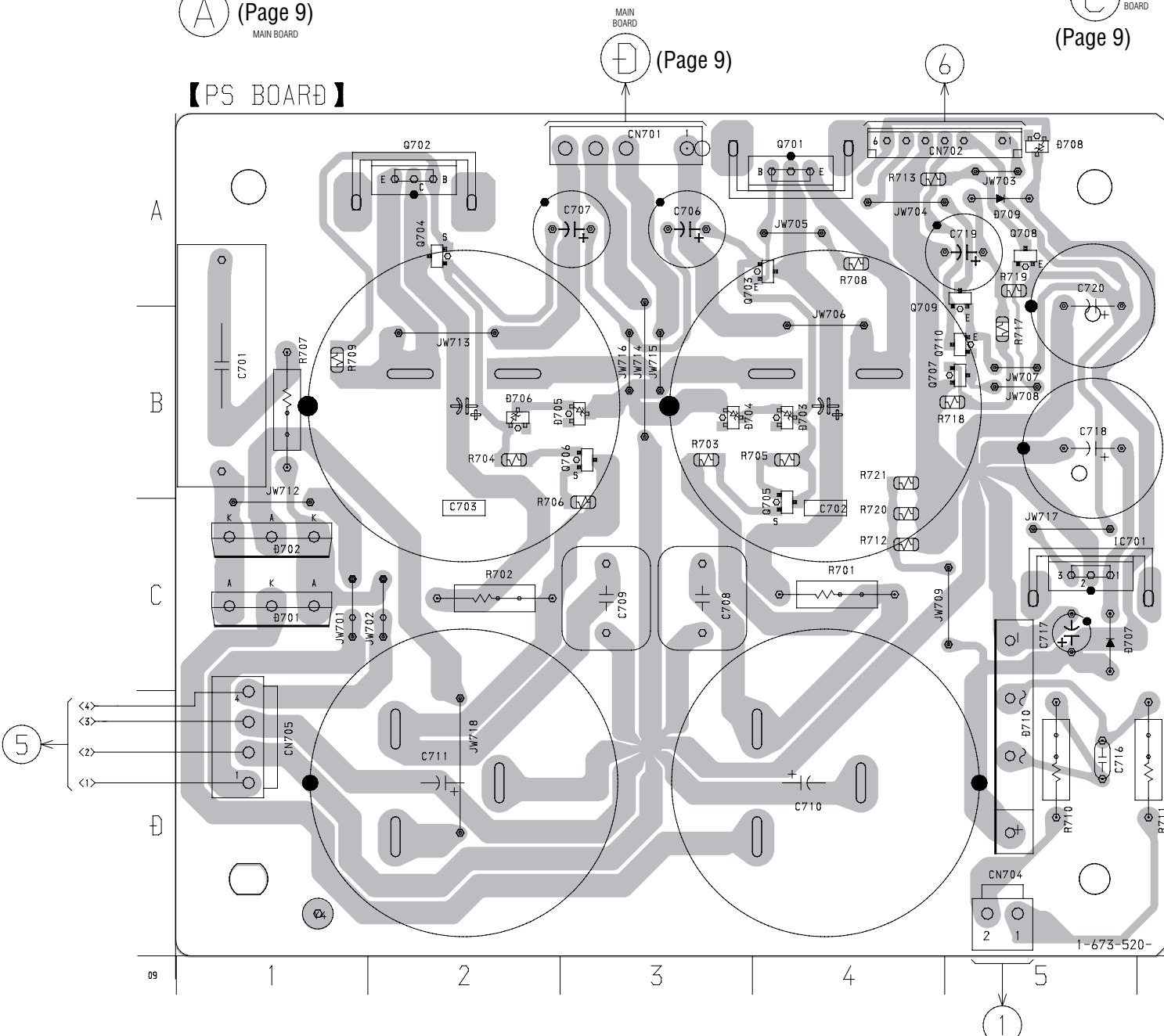

• Semiconductor Location

Ref. No	Location
D701	C-1
D702	C-1
D703	B-4
D704	B-3
D705	B-3
D706	B-2
D707	C-5
D708	A-5
D709	A-5
D710	D-5
IC701	C-5
Q701	A-4
Q702	A-2
Q703	A-4
Q704	A-2
Q705	C-4
Q706	B-3
Q707	B-5
Q708	A-5
Q709	A-5
Q710	B-5

【AC J BOARD】

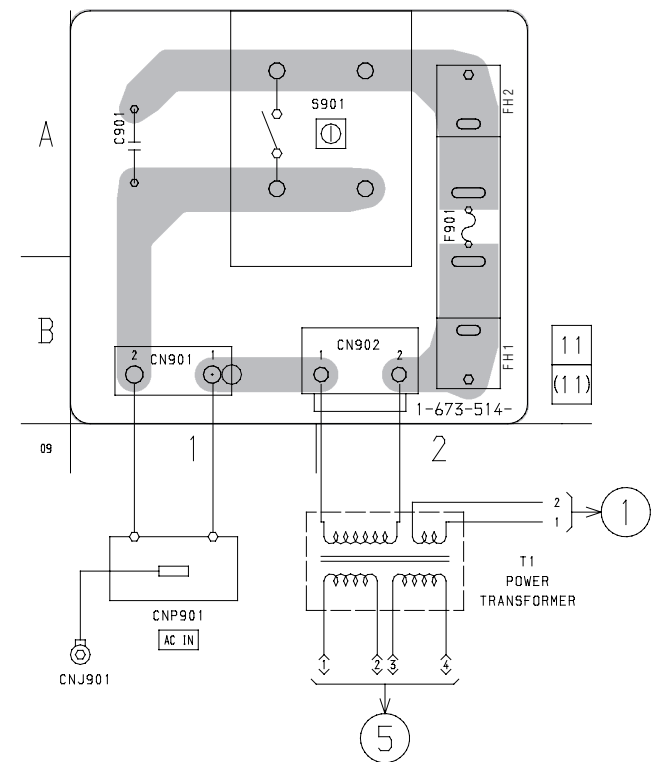

SECTION 4 EXPLODED VIEWS

NOTE:

- -XX, -X mean standardized parts, so they may have some difference from the original one.
- Items marked “*” are not stocked since they are seldom required for routine service. Some delay should be anticipated when ordering these items.
- The mechanical parts with no reference number in the exploded views are not supplied.

- Hardware (# mark) list and accessories and packing materials are given in the last of this parts list.
- Abbreviation
CND : Canadian model

The components identified by mark Δ or dotted line with mark Δ are critical for safety. Replace only with part number specified.

Les composants identifiés par une marque Δ sont critiques pour la sécurité. Ne les remplacer que par une pièce portant le numéro spécifié.

4-1. TOP PLATE AND BACK PANEL SECTION

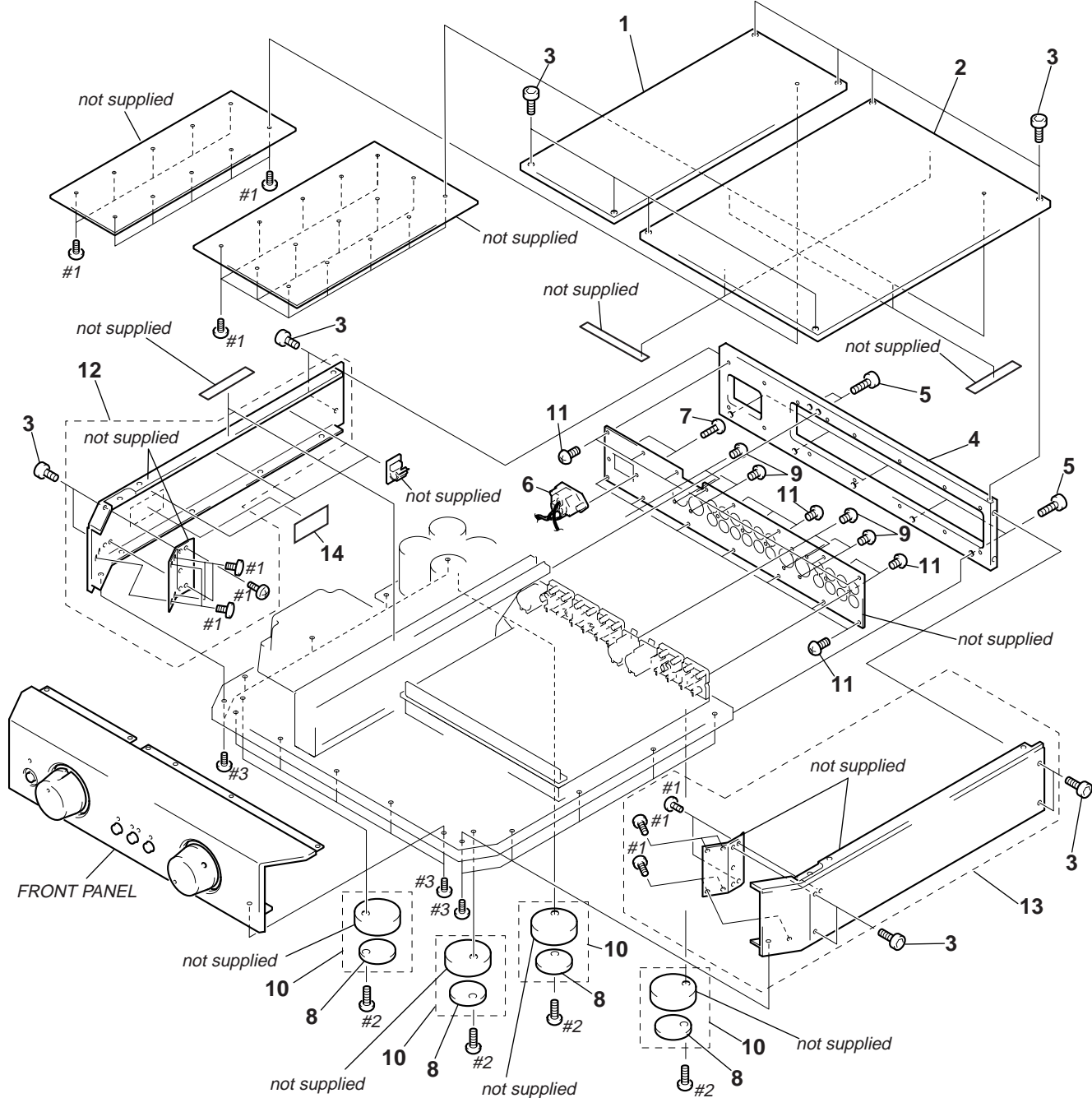

Ref. No.	Part No.	Description	Remark	Ref. No.	Part No.	Description	Remark
1	4-214-524-01	PLATE (L), TOP		7	4-911-049-21	SCREW (3X8)	
2	4-214-525-01	PLATE (R), TOP		8	4-970-124-11	CUSHION (F50180S)	
3	4-988-742-11	SCREW (M3X8), HEXAGON SOCKET		9	3-703-685-41	SCREW (A+BV 3X8)	
4	4-214-526-13	PANEL, BACK (US,CND)		10	X-4951-584-1	FOOT ASSY	
4	4-214-526-22	PANEL, BACK (EXCEPT US,CND)		11	4-974-510-01	SCREW (+BV 3X8 CU)	
* 5	3-910-074-01	BOLT (M3)		12	X-4951-020-1	PLATE (L) ASSY,ORNAMENTAL SIDE	
6	1-580-375-41	INLET 3P		13	X-4951-021-1	PLATE (R) ASSY,ORNAMENTAL SIDE	
				* 14	3-703-044-26	LABEL, CAUTION (US,CND)	

4-2. FRONT PANEL SECTION

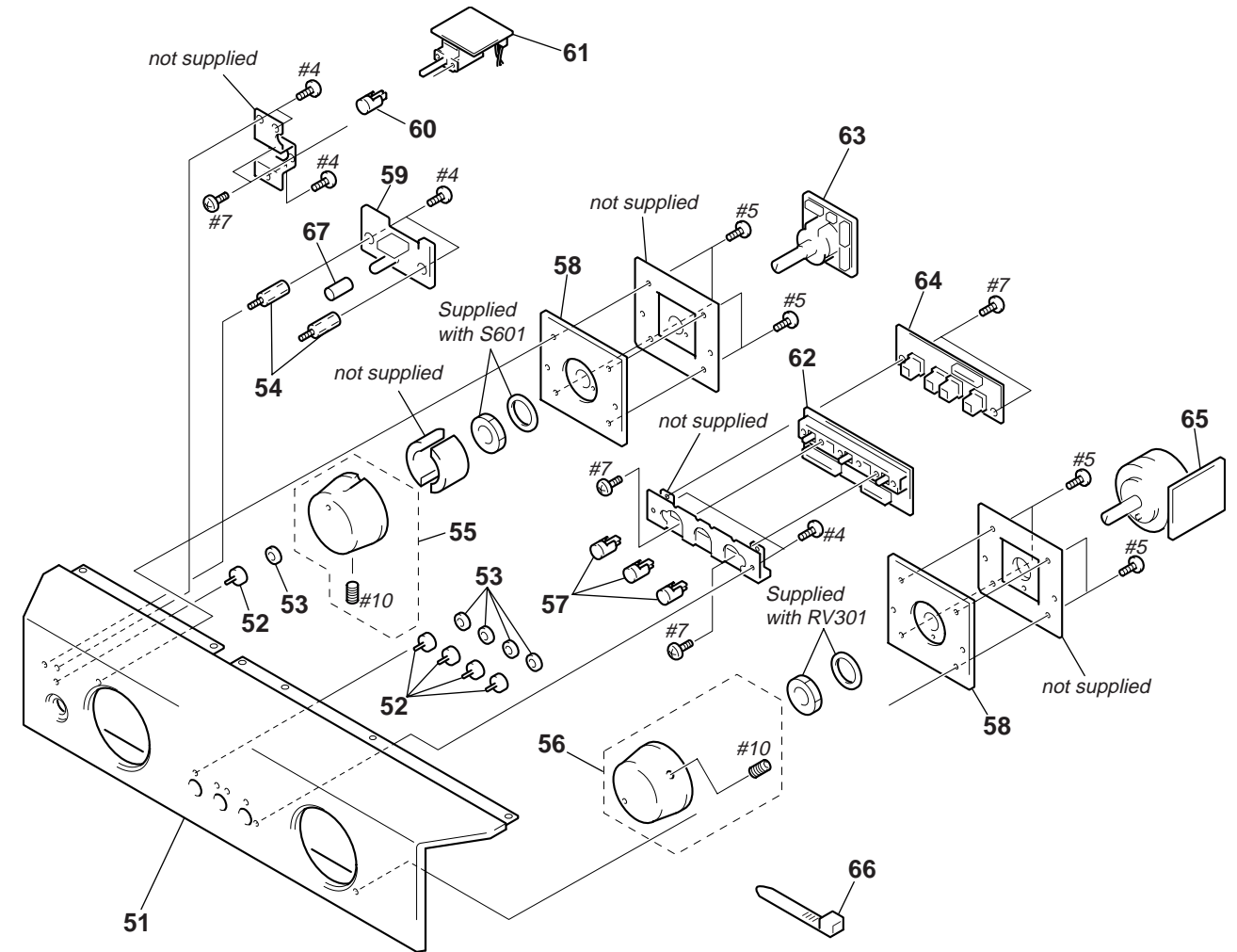

Ref. No.	Part No.	Description	Remark	Ref. No.	Part No.	Description	Remark
51	4-214-521-01	PANEL, FRONT		60	X-4950-854-1	BUTTON ASSY, POWER	
* 52	4-986-734-01	LENS, LED		61	1-673-514-11	AC J BOARD	
53	4-214-533-01	RETAINER, LENS		62	1-673-518-11	SW P BOARD	
54	4-214-620-01	SUPPORT (C)		63	1-673-513-11	SW L BOARD	
55	4-214-532-01	KNOB (VOL)		64	1-673-517-11	LED B BOARD	
56	4-214-545-01	KNOB (SELECTER)		65	1-673-519-11	VOL BOARD	
57	X-4950-674-1	BUTTON ASSY		66	3-655-653-21	BAND (TAITON), BINDING	
58	4-214-535-01	WINDOW, MIRROR		67	4-221-587-01	TUBE, LIGHT INTERCEPTION	
59	1-673-516-11	LED A BOARD (EXCEPT US,CND)					

4-3. BOTTOM PLATE SECTION

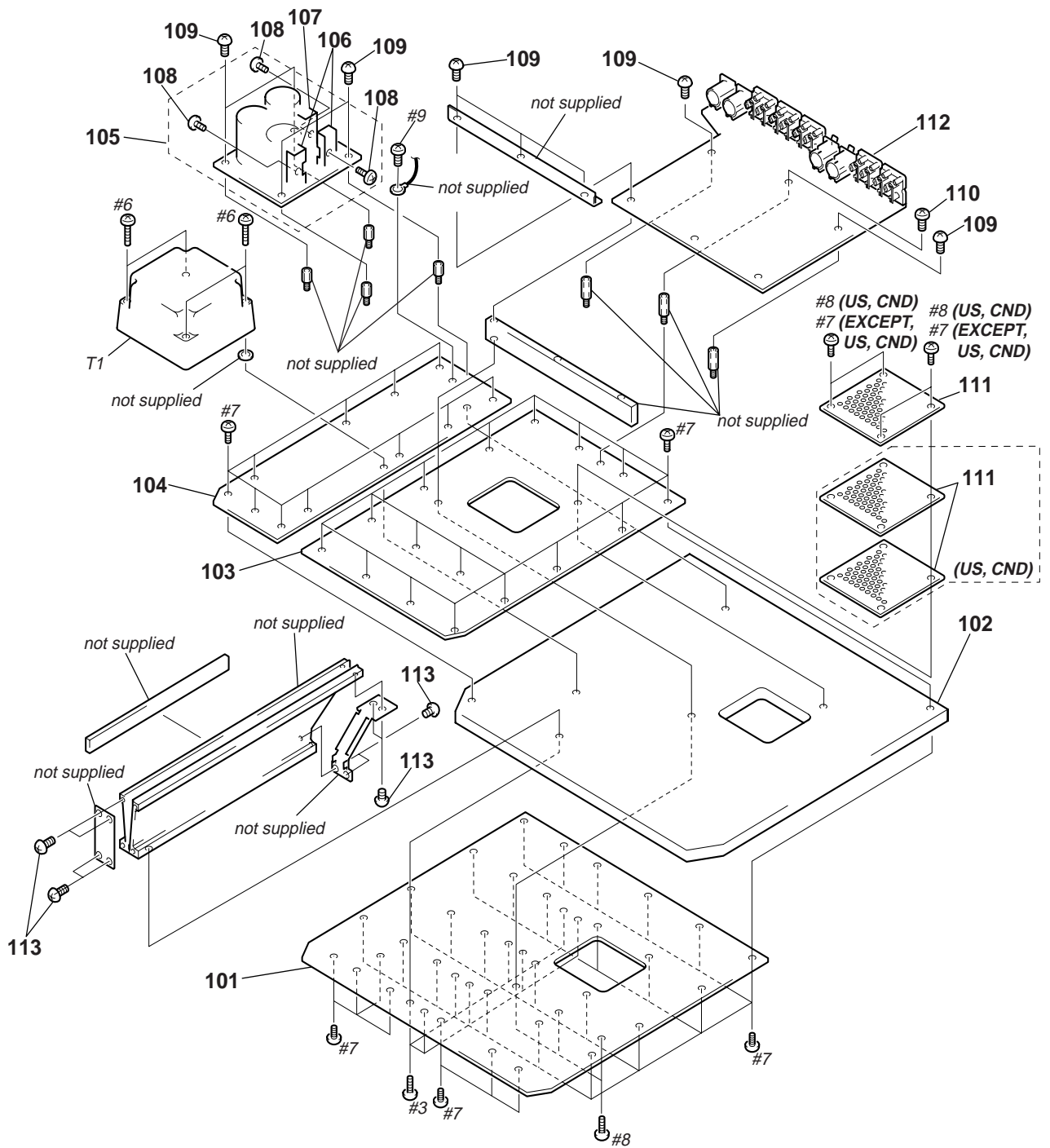

<p>The components identified by mark Δ or dotted line with mark Δ are critical for safety. Replace only with part number specified.</p>	<p>Les composants identifiés par une marque Δ sont critiques pour la sécurité. Ne les remplacer que par une pièce portant le numéro spécifié.</p>
---	---

Ref. No.	Part No.	Description	Remark	Ref. No.	Part No.	Description	Remark
101	4-219-714-01	PLATE (A), BOTTOM		109	4-967-960-01	SCREW (4X8)	
102	4-214-527-01	PLATE, BOTTOM		* 110	4-931-964-01	SCREW (M4X6)	
103	4-219-712-01	PLATE (A), TOP		* 111	1-641-950-11	PC BOARD, BOTTOM LID	
104	4-219-713-01	PLATE (B), TOP		112	A-4426-205-A	MAIN BOARD, COMPLETE (US,CND)	
105	A-4426-207-A	PS BOARD, COMPLETE (US,CND)		112	A-4426-208-A	MAIN BOARD, COMPLETE (EXCEPT US,CND)	
105	A-4426-210-A	PS BOARD, COMPLETE (EXCEPT US,CND)		113	4-974-510-01	SCREW (+BV 3X8 CU)	
* 106	4-941-237-01	HEAT SINK		Δ T1	1-433-981-11	TRANSFORMER, POWER (EXCEPT US,CND)	
107	4-902-345-01	HEAT SINK		Δ T1	1-433-982-11	TRANSFORMER, POWER (US,CND)	
108	2-259-121-01	SCREW, TR					

AC J**LED A****LED B****MAIN****SECTION 5
ELECTRICAL PARTS LIST****Note:**

The components identified by mark Δ or dotted line with mark Δ are critical for safety. Replace only with part number specified.

Les composants identifiés par une marque Δ sont critiques pour la sécurité. Ne les remplacer que par une pièce portant le numéro spécifié.

When indicating parts by reference number, please include the board name.

- Due to standardization, replacements in the parts list may be different from the parts specified in the diagrams or the components used on the set.
- -XX, -X mean standardized parts, so they may have some difference from the original one.
- Items marked "*" are not stocked since they are seldom required for routine service. Some delay should be anticipated when ordering these items.
- RESISTORS
All resistors are in ohms
METAL: Metal-film resistor
METAL OXIDE: Metal Oxide-film resistor
F : nonflammable
- SEMICONDUCTORS
In each case, u: μ , for example:
uA...: μ A..., uPA...: μ PA..., uPB...: μ PB...,
uPC...: μ PC..., uPD...: μ PD...
- CAPACITORS
uF : μ F
- COILS
uH : μ H
- Abbreviation
CND : Canadian model

Ref. No.	Part No.	Description	Remark	Ref. No.	Part No.	Description	Remark
	1-673-514-11	AC J BOARD *****				< DIODE >	
	1-533-798-11	HOLDER, FUSE < CAPACITOR >		D601	8-719-046-38	DIODE SEL5821A-TH8F (TAPE MONITOR)	
Δ C901	1-113-920-11	CERAMIC 0.0022uF 20% 250V < CONNECTOR >		D602	8-719-046-38	DIODE SEL5821A-TH8F (TAPE 1)	
CN902	1-564-321-00	PIN, CONNECTOR 2P < FUSE >		D603	8-719-046-38	DIODE SEL5821A-TH8F (TAPE 2)	
Δ F901	1-532-463-51	FUSE (1A/250)(EXCEPT US,CND)		D604	8-719-046-38	DIODE SEL5821A-TH8F (DIRECT)	
Δ F901	1-532-742-11	FUSE, GLASS TUBE (1.6A/125V)(US,CND) < SWITCH >		*****			
Δ S901	1-771-187-11	SWITCH, AC POWER (Ⓞ)		A-4426-205-A	MAIN BOARD, COMPLETE (US,CND) *****		
*****				A-4426-208-A	MAIN BOARD, COMPLETE (EXCEPT US,CND) *****		
	1-673-516-11	LED A BOARD ***** < CAPACITOR >		4-835-639-00	PLATE, GROUND < CAPACITOR >		
C801	1-115-339-11	CERAMIC CHIP 0.1uF 10% 50V		C223	1-115-339-11	CERAMIC CHIP 0.1uF 10% 50V	
C802	1-115-339-11	CERAMIC CHIP 0.1uF 10% 50V < CONNECTOR >		C224	1-115-339-11	CERAMIC CHIP 0.1uF 10% 50V	
CN801	1-691-765-11	PLUG (MICRO CONNECTOR) 3P < DIODE >		C225	1-115-339-11	CERAMIC CHIP 0.1uF 10% 50V	
D801	8-719-313-40	DIODE SML1516W (Ⓞ)		C226	1-115-339-11	CERAMIC CHIP 0.1uF 10% 50V	
*****				C227	1-115-339-11	CERAMIC CHIP 0.1uF 10% 50V	
	1-673-517-11	LED B BOARD ***** < CAPACITOR >		C228	1-115-339-11	CERAMIC CHIP 0.1uF 10% 50V	
C605	1-163-021-91	CERAMIC CHIP 0.01uF 10% 50V		C229	1-115-339-11	CERAMIC CHIP 0.1uF 10% 50V	
C606	1-163-021-91	CERAMIC CHIP 0.01uF 10% 50V		C230	1-115-339-11	CERAMIC CHIP 0.1uF 10% 50V	
C607	1-163-021-91	CERAMIC CHIP 0.01uF 10% 50V		C231	1-115-339-11	CERAMIC CHIP 0.1uF 10% 50V	
C608	1-163-021-91	CERAMIC CHIP 0.01uF 10% 50V		C232	1-115-339-11	CERAMIC CHIP 0.1uF 10% 50V	
				C233	1-115-339-11	CERAMIC CHIP 0.1uF 10% 50V	
				C234	1-115-339-11	CERAMIC CHIP 0.1uF 10% 50V	
				C237	1-163-009-11	CERAMIC CHIP 0.001uF 10% 50V	
				C238	1-163-009-11	CERAMIC CHIP 0.001uF 10% 50V	
				C239	1-163-009-11	CERAMIC CHIP 0.001uF 10% 50V	
				C240	1-163-009-11	CERAMIC CHIP 0.001uF 10% 50V	
				C241	1-163-009-11	CERAMIC CHIP 0.001uF 10% 50V	
				C242	1-163-009-11	CERAMIC CHIP 0.001uF 10% 50V	
				C243	1-163-009-11	CERAMIC CHIP 0.001uF 10% 50V	
				C244	1-163-009-11	CERAMIC CHIP 0.001uF 10% 50V	
				C245	1-163-009-11	CERAMIC CHIP 0.001uF 10% 50V	
				C246	1-163-009-11	CERAMIC CHIP 0.001uF 10% 50V	
				C247	1-125-845-21	FILM 47PF 10% 50V	
				C248	1-125-845-21	FILM 47PF 10% 50V	
				C249	1-163-009-11	CERAMIC CHIP 0.001uF 10% 50V	
				C250	1-163-009-11	CERAMIC CHIP 0.001uF 10% 50V	
				C401	1-110-512-51	FILM 1uF 10% 50V	
				C402	1-110-512-51	FILM 1uF 10% 50V	

Ref. No.	Part No.	Description	Remark	Ref. No.	Part No.	Description	Remark
C403	1-128-200-11	ELECT	47uF 20% 50V	CP103	1-418-107-11	AMPLIFIER UNIT	
C404	1-128-200-11	ELECT	47uF 20% 50V	CP104	1-418-107-11	AMPLIFIER UNIT	
C405	1-110-512-51	FILM	1uF 10% 50V			< DIODE >	
C406	1-110-512-51	FILM	1uF 10% 50V	D201	8-719-800-76	DIODE 1SS226	
C407	1-128-972-11	ELECT	1000uF 20% 50V	D202	8-719-800-76	DIODE 1SS226	
C408	1-128-972-11	ELECT	1000uF 20% 50V	D203	8-719-800-76	DIODE 1SS226	
C409	1-128-973-11	ELECT	470uF 20% 25V	D204	8-719-800-76	DIODE 1SS226	
C410	1-128-973-11	ELECT	470uF 20% 25V	D205	8-719-800-76	DIODE 1SS226	
C411	1-128-200-11	ELECT	47uF 20% 50V	D206	8-719-800-76	DIODE 1SS226	
C412	1-128-200-11	ELECT	47uF 20% 50V	D207	8-719-800-76	DIODE 1SS226	
C413	1-128-200-11	ELECT	47uF 20% 50V	D208	8-719-800-76	DIODE 1SS226	
C414	1-128-200-11	ELECT	47uF 20% 50V	D209	8-719-800-76	DIODE 1SS226	
C419	1-110-512-51	FILM	1uF 10% 50V	D210	8-719-800-76	DIODE 1SS226	
C420	1-110-512-51	FILM	1uF 10% 50V	D211	8-719-800-76	DIODE 1SS226	
C421	1-128-972-11	ELECT	1000uF 20% 50V	D212	8-719-800-76	DIODE 1SS226	
C422	1-128-972-11	ELECT	1000uF 20% 50V	D401	8-719-025-51	DIODE 02CZ18-TE85L	
C423	1-128-973-11	ELECT	470uF 20% 25V	D402	8-719-025-51	DIODE 02CZ18-TE85L	
C424	1-128-973-11	ELECT	470uF 20% 25V	D403	8-719-025-51	DIODE 02CZ18-TE85L	
C501	1-125-850-21	FILM	220PF 5% 50V	D404	8-719-025-51	DIODE 02CZ18-TE85L	
C502	1-125-850-21	FILM	220PF 5% 50V	D405	8-719-025-47	DIODE 02CZ12-TE85L	
C503	1-110-512-51	FILM	1uF 10% 50V	D406	8-719-025-47	DIODE 02CZ12-TE85L	
C504	1-110-512-51	FILM	1uF 10% 50V	D407	8-719-025-47	DIODE 02CZ12-TE85L	
C505	1-128-971-11	ELECT	220uF 20% 50V	D408	8-719-025-47	DIODE 02CZ12-TE85L	
C506	1-128-971-11	ELECT	220uF 20% 50V	D501	8-719-025-51	DIODE 02CZ18-TE85L	
C507	1-128-971-11	ELECT	220uF 20% 50V	D502	8-719-025-51	DIODE 02CZ18-TE85L	
C508	1-128-971-11	ELECT	220uF 20% 50V	D503	8-719-025-47	DIODE 02CZ12-TE85L	
C509	1-128-973-11	ELECT	470uF 20% 25V	D504	8-719-025-47	DIODE 02CZ12-TE85L	
C510	1-128-973-11	ELECT	470uF 20% 25V	D505	8-719-025-47	DIODE 02CZ12-TE85L	
C511	1-128-972-11	ELECT	1000uF 20% 50V	D506	8-719-025-47	DIODE 02CZ12-TE85L	
C512	1-128-972-11	ELECT	1000uF 20% 50V			< JACK >	
C513	1-110-512-51	FILM	1uF 10% 50V	J201	1-785-547-11	JACK, PIN (LINE 1, 2 L/R)	
C514	1-110-512-51	FILM	1uF 10% 50V	J202	1-785-547-11	JACK, PIN (CD, SACD L/R)	
C515	1-128-973-11	ELECT	470uF 20% 25V	J203	1-785-547-11	JACK, PIN (DIRECT L/R, TAPE2/MD IN L/R)	
C516	1-128-973-11	ELECT	470uF 20% 25V	J204	1-785-547-11	JACK, PIN	
C517	1-126-017-11	ELECT	6800uF 20% 16V			(TAPE2/MD OUT L/R, TAPE1/DAT IN L/R)	
C518	1-126-017-11	ELECT	6800uF 20% 16V	J205	1-785-547-11	JACK, PIN (TAPE1/DAT OUT L/R, PRE OUT L/R)	
C519	1-110-512-51	FILM	1uF 10% 50V			< BUS BAR >	
C520	1-110-512-51	FILM	1uF 10% 50V	* JWH201	1-569-135-11	BAR, BUS 4P	
C521	1-128-973-11	ELECT	470uF 20% 25V	* JWH202	1-569-135-11	BAR, BUS 4P	
C522	1-128-973-11	ELECT	470uF 20% 25V	* JWH203	1-691-275-11	BUS BAR	
C523	1-128-972-11	ELECT	1000uF 20% 50V	* JWH204	1-569-135-11	BAR, BUS 4P	
C524	1-128-972-11	ELECT	1000uF 20% 50V	* JWH205	1-569-135-11	BAR, BUS 4P	
C525	1-110-512-51	FILM	1uF 10% 50V	* JWH206	1-691-275-11	BUS BAR	
C526	1-110-512-51	FILM	1uF 10% 50V			< TRANSISTOR >	
		< CONNECTOR >		Q201	8-729-424-08	TRANSISTOR	UN2111
CN201	1-766-803-11	CONNECTOR (CANON)		Q202	8-729-424-08	TRANSISTOR	UN2111
CN202	1-766-803-11	CONNECTOR (CANON)		Q203	8-729-424-08	TRANSISTOR	UN2111
CN203	1-785-548-11	CONNECTOR (RECEPTACLE)		Q204	8-729-424-08	TRANSISTOR	UN2111
CN204	1-785-548-11	CONNECTOR (RECEPTACLE)		Q205	8-729-424-08	TRANSISTOR	UN2111
CN205	1-691-768-11	PLUG (MICRO CONNECTOR) 6P		Q206	8-729-424-08	TRANSISTOR	UN2111
CN206	1-691-769-11	PLUG (MICRO CONNECTOR) 7P		Q207	8-729-424-08	TRANSISTOR	UN2111
* CN207	1-564-241-11	PIN, CONNECTOR (B4P-VH) 4P		Q208	8-729-424-08	TRANSISTOR	UN2111
		< COMPOSITION CIRCUIT BLOCK >		Q209	8-729-424-08	TRANSISTOR	UN2111
CP101	1-233-250-11	ENCAPSULATED COMPONENT		Q210	8-729-424-08	TRANSISTOR	UN2111
CP102	1-418-106-11	AMPLIFIER UNIT					

MAIN

Ref. No.	Part No.	Description	Remark	Ref. No.	Part No.	Description	Remark
Q211	8-729-424-08	TRANSISTOR	UN2111	R211	1-260-032-11	CARBON MELF 1M	2% 1/8W
Q212	8-729-424-08	TRANSISTOR	UN2111	R212	1-260-032-11	CARBON MELF 1M	2% 1/8W
Q214	8-729-421-22	TRANSISTOR	UN2211	R213	1-260-032-11	CARBON MELF 1M	2% 1/8W
Q215	8-729-421-22	TRANSISTOR	UN2211	R214	1-260-032-11	CARBON MELF 1M	2% 1/8W
Q216	8-729-421-22	TRANSISTOR	UN2211	R215	1-260-032-11	CARBON MELF 1M	2% 1/8W
Q217	8-729-421-22	TRANSISTOR	UN2211	R216	1-260-032-11	CARBON MELF 1M	2% 1/8W
Q218	8-729-421-22	TRANSISTOR	UN2211	R217	1-260-032-11	CARBON MELF 1M	2% 1/8W
Q219	8-729-421-22	TRANSISTOR	UN2211	R218	1-260-032-11	CARBON MELF 1M	2% 1/8W
Q220	8-729-421-22	TRANSISTOR	UN2211	R219	1-260-020-11	CARBON MELF 100K	2% 1/8W
Q221	8-729-421-22	TRANSISTOR	UN2211	R220	1-260-020-11	CARBON MELF 100K	2% 1/8W
Q222	8-729-421-22	TRANSISTOR	UN2211	R221	1-260-032-11	CARBON MELF 1M	2% 1/8W
Q223	8-729-421-22	TRANSISTOR	UN2211	R222	1-260-032-11	CARBON MELF 1M	2% 1/8W
Q224	8-729-421-22	TRANSISTOR	UN2211	R223	1-260-032-11	CARBON MELF 1M	2% 1/8W
Q225	8-729-421-22	TRANSISTOR	UN2211	R224	1-260-032-11	CARBON MELF 1M	2% 1/8W
Q401	8-729-047-96	TRANSISTOR	2SC3645-S	R225	1-260-032-11	CARBON MELF 1M	2% 1/8W
Q402	8-729-047-94	TRANSISTOR	2SA1415-S	R226	1-260-032-11	CARBON MELF 1M	2% 1/8W
Q403	8-729-271-31	TRANSISTOR	2SC2713-G	R227	1-249-186-11	CARBON 100	1% 1/3W
Q404	8-729-216-31	TRANSISTOR	2SA1163-G	R228	1-249-186-11	CARBON 100	1% 1/3W
Q405	8-729-232-69	TRANSISTOR	2SK208-GRT5LSONY-1	R229	1-259-644-11	CARBON 47	2% 1W
Q406	8-729-232-69	TRANSISTOR	2SK208-GRT5LSONY-1	R230	1-259-644-11	CARBON 47	2% 1W
Q407	8-729-047-96	TRANSISTOR	2SC3645-S	R231	1-259-531-11	CARBON 100	1% 1/2W
Q408	8-729-047-94	TRANSISTOR	2SA1415-S	R232	1-259-531-11	CARBON 100	1% 1/2W
Q409	8-729-271-31	TRANSISTOR	2SC2713-G	R233	1-249-186-11	CARBON 100	1% 1/3W
Q410	8-729-216-31	TRANSISTOR	2SA1163-G	R234	1-249-186-11	CARBON 100	1% 1/3W
Q411	8-729-232-69	TRANSISTOR	2SK208-GRT5LSONY-1	R235	1-259-995-11	CARBON MELF 1K	2% 1/8W
Q412	8-729-232-69	TRANSISTOR	2SK208-GRT5LSONY-1	R236	1-259-995-11	CARBON MELF 1K	2% 1/8W
Q501	8-729-271-31	TRANSISTOR	2SC2713-G	△R401	1-202-937-41	FUSIBLE 10	5% 1/2W
Q502	8-729-271-31	TRANSISTOR	2SC2713-G	△R402	1-202-937-41	FUSIBLE 10	5% 1/2W
Q503	8-729-047-96	TRANSISTOR	2SC3645-S	R403	1-259-999-11	CARBON MELF 2.2K	2% 1/8W
Q504	8-729-047-94	TRANSISTOR	2SA1415-S	R404	1-259-999-11	CARBON MELF 2.2K	2% 1/8W
Q505	8-729-271-31	TRANSISTOR	2SC2713-G	R405	1-259-987-11	CARBON MELF 220	2% 1/8W
Q506	8-729-216-31	TRANSISTOR	2SA1163-G	R406	1-259-987-11	CARBON MELF 220	2% 1/8W
Q507	8-729-232-69	TRANSISTOR	2SK208-GRT5LSONY-1	R407	1-259-995-11	CARBON MELF 1K	2% 1/8W
Q508	8-729-232-69	TRANSISTOR	2SK208-GRT5LSONY-1	R408	1-259-995-11	CARBON MELF 1K	2% 1/8W
Q509	8-729-047-96	TRANSISTOR	2SC3645-S	△R409	1-202-937-41	FUSIBLE 10	5% 1/2W
Q510	8-729-047-94	TRANSISTOR	2SA1415-S	△R410	1-202-937-41	FUSIBLE 10	5% 1/2W
Q511	8-729-271-31	TRANSISTOR	2SC2713-G	R411	1-259-999-11	CARBON MELF 2.2K	2% 1/8W
Q512	8-729-216-31	TRANSISTOR	2SA1163-G	R412	1-259-999-11	CARBON MELF 2.2K	2% 1/8W
Q513	8-729-232-69	TRANSISTOR	2SK208-GRT5LSONY-1	R413	1-259-987-11	CARBON MELF 220	2% 1/8W
Q514	8-729-232-69	TRANSISTOR	2SK208-GRT5LSONY-1	R414	1-259-987-11	CARBON MELF 220	2% 1/8W
Q515	8-729-232-69	TRANSISTOR	2SK208-GRT5LSONY-1	R415	1-259-995-11	CARBON MELF 1K	2% 1/8W
Q516	8-729-232-69	TRANSISTOR	2SK208-GRT5LSONY-1	R416	1-259-995-11	CARBON MELF 1K	2% 1/8W
Q517	8-729-047-96	TRANSISTOR	2SC3645-S	R501	1-259-668-61	CARBON 470	2% 1W
Q518	8-729-047-94	TRANSISTOR	2SA1415-S	R502	1-259-668-61	CARBON 470	2% 1W
Q519	8-729-271-31	TRANSISTOR	2SC2713-G	R503	1-259-535-61	CARBON 150	1% 1/2W
Q520	8-729-216-31	TRANSISTOR	2SA1163-G	R504	1-259-535-61	CARBON 150	1% 1/2W
		< RESISTOR >		R505	1-259-668-61	CARBON 470	2% 1W
				R506	1-259-668-61	CARBON 470	2% 1W
R201	1-260-032-11	CARBON MELF 1M	2% 1/8W	R507	1-260-002-11	CARBON MELF 3.3K	2% 1/8W
R202	1-260-032-11	CARBON MELF 1M	2% 1/8W	R508	1-259-991-11	CARBON MELF 470	2% 1/8W
R203	1-260-032-11	CARBON MELF 1M	2% 1/8W	R509	1-260-002-11	CARBON MELF 3.3K	2% 1/8W
R204	1-260-032-11	CARBON MELF 1M	2% 1/8W	R510	1-259-991-11	CARBON MELF 470	2% 1/8W
R205	1-260-032-11	CARBON MELF 1M	2% 1/8W	R511	1-259-999-11	CARBON MELF 2.2K	2% 1/8W
R206	1-260-032-11	CARBON MELF 1M	2% 1/8W	R512	1-259-999-11	CARBON MELF 2.2K	2% 1/8W
R207	1-260-032-11	CARBON MELF 1M	2% 1/8W	R513	1-259-987-11	CARBON MELF 220	2% 1/8W
R208	1-260-032-11	CARBON MELF 1M	2% 1/8W	R514	1-259-987-11	CARBON MELF 220	2% 1/8W
R209	1-260-032-11	CARBON MELF 1M	2% 1/8W	△R515	1-202-937-41	FUSIBLE 10	5% 1/2W
R210	1-260-032-11	CARBON MELF 1M	2% 1/8W				

The components identified by mark △ or dotted line with mark △ are critical for safety. Replace only with part number specified.	Les composants identifiés par une marque △ sont critiques pour la sécurité. Ne les remplacer que par une pièce portant le numéro spécifié.
---	---

Ref. No.	Part No.	Description	Remark
△ R516	1-202-937-41	FUSIBLE 10 5%	1/2W
△ R517	1-202-937-41	FUSIBLE 10 5%	1/2W
△ R518	1-202-937-41	FUSIBLE 10 5%	1/2W
R519	1-259-995-11	CARBON MELF 1K 2%	1/8W
R520	1-259-995-11	CARBON MELF 1K 2%	1/8W
R521	1-259-999-11	CARBON MELF 2.2K 2%	1/8W
R522	1-259-999-11	CARBON MELF 2.2K 2%	1/8W
R523	1-259-987-11	CARBON MELF 220 2%	1/8W
R524	1-259-987-11	CARBON MELF 220 2%	1/8W
R525	1-259-995-11	CARBON MELF 1K 2%	1/8W
R526	1-259-995-11	CARBON MELF 1K 2%	1/8W
△ R527	1-202-937-41	FUSIBLE 10 5%	1/2W
△ R528	1-202-937-41	FUSIBLE 10 5%	1/2W
R529	1-259-999-11	CARBON MELF 2.2K 2%	1/8W
R530	1-259-999-11	CARBON MELF 2.2K 2%	1/8W
R531	1-259-987-11	CARBON MELF 220 2%	1/8W
R532	1-259-987-11	CARBON MELF 220 2%	1/8W
R533	1-259-995-11	CARBON MELF 1K 2%	1/8W
R534	1-259-995-11	CARBON MELF 1K 2%	1/8W
R535	1-249-162-11	CARBON 10 1%	1/3W
R536	1-249-162-11	CARBON 10 1%	1/3W
< VARIABLE RESISTOR >			
RV401	1-224-250-11	RES, ADJ, METAL GLAZE 2.2K (BALANCED LEVEL LCH)	
RV402	1-224-250-11	RES, ADJ, METAL GLAZE 2.2K (BALANCED LEVEL RCH)	
RV501	1-224-249-11	RES, ADJ, METAL GLAZE 1K (IDLER LCH)	
RV502	1-224-249-11	RES, ADJ, METAL GLAZE 1K (IDLER RCH)	
< RELAY >			
RY101	1-755-062-11	RELAY	
RY102	1-755-062-11	RELAY	
RY103	1-755-062-11	RELAY	
RY104	1-755-062-11	RELAY	
RY105	1-755-062-11	RELAY	
RY106	1-755-062-11	RELAY	
RY107	1-755-062-11	RELAY	
RY108	1-755-062-11	RELAY	
RY109	1-755-062-11	RELAY	
RY110	1-755-062-11	RELAY	
RY111	1-755-062-11	RELAY	
RY112	1-755-062-11	RELAY	
RY113	1-755-062-11	RELAY	
< TEST PIN >			
* TP501	3-657-235-00	POINT, TEST	
* TP502	3-657-235-00	POINT, TEST	
* TP503	3-657-235-00	POINT, TEST	
* TP504	3-657-235-00	POINT, TEST	

A-4426-207-A PS BOARD, COMPLETE (US,CND)

A-4426-210-A PS BOARD, COMPLETE (EXCEPT US,CND)

Ref. No.	Part No.	Description	Remark
< CAPACITOR >			
C701	1-136-880-11	FILM 2.2uF 10%	160V
C702	1-128-998-11	ELECT 6800uF 20%	35V
C703	1-128-998-11	ELECT 6800uF 20%	35V
C706	1-128-200-11	ELECT 47uF 20%	50V
C707	1-128-200-11	ELECT 47uF 20%	50V
C708	1-117-775-31	FILM 0.1uF 10%	250V
C709	1-117-775-31	FILM 0.1uF 10%	250V
C710	1-127-982-11	ELECT 3900uF 20%	50V
C711	1-127-981-11	ELECT 3900uF 20%	50V
C716	1-130-955-11	FILM 0.01uF 2%	100V
C717	1-119-847-11	ELECT 2.2uF 20%	100V
C718	1-119-815-21	ELECT 2200uF 20%	35V
C719	1-126-025-11	ELECT 330uF 20%	25V
C720	1-119-804-21	ELECT 1000uF 20%	25V
< CONNECTOR >			
CN702	1-564-510-11	PLUG (MICRO CONNECTOR) 6P	
CN704	1-564-320-00	PIN, CONNECTOR (B2P-VH) 2P	
* CN705	1-564-241-11	PIN, CONNECTOR (B4P-VH) 4P	
< DIODE >			
D701	8-719-200-39	DIODE C16P20F	
D702	8-719-200-40	DIODE C16P20FR	
D703	8-719-025-49	DIODE 02CZ15-TE85L	
D704	8-719-025-49	DIODE 02CZ15-TE85L	
D705	8-719-025-49	DIODE 02CZ15-TE85L	
D706	8-719-025-49	DIODE 02CZ15-TE85L	
D707	8-719-200-82	DIODE 11ES2	
D708	8-719-025-47	DIODE 02CZ12-TE85L	
D709	8-719-200-82	DIODE 11ES2	
D710	8-719-070-64	DIODE RBV-602L	
< IC >			
IC701	8-759-605-03	IC M5F78M24L	
< TRANSISTOR >			
Q701	8-729-141-58	TRANSISTOR 2SC2275A-Q	
Q702	8-729-141-10	TRANSISTOR 2SA985A-Q	
Q703	8-729-271-31	TRANSISTOR 2SC2713-G	
Q704	8-729-216-31	TRANSISTOR 2SA1163-G	
Q705	8-729-232-69	TRANSISTOR 2SK208-GRT5LSONY-1	
Q706	8-729-232-69	TRANSISTOR 2SK208-GRT5LSONY-1	
Q707	8-729-271-31	TRANSISTOR 2SC2713-G	
Q708	8-729-424-08	TRANSISTOR UN2111	
Q709	8-729-424-08	TRANSISTOR UN2111	
Q710	8-729-424-08	TRANSISTOR UN2111	
< RESISTOR >			
△ R701	1-202-937-41	FUSIBLE 10 5%	1/2W
△ R702	1-202-937-41	FUSIBLE 10 5%	1/2W
R703	1-259-999-11	CARBON MELF 2.2K 2%	1/8W
R704	1-259-999-11	CARBON MELF 2.2K 2%	1/8W
R705	1-259-987-11	CARBON MELF 220 2%	1/8W
R706	1-259-987-11	CARBON MELF 220 2%	1/8W
△ R707	1-202-937-41	FUSIBLE 10 5%	1/2W
R708	1-259-995-11	CARBON MELF 1K 2%	1/8W

The components identified by mark △ or dotted line with mark △ are critical for safety. Replace only with part number specified.	Les composants identifiés par une marque △ sont critiques pour la sécurité. Ne les remplacer que par une pièce portant le numéro spécifié.
---	---

TA-E1

PS SW L SW P VOL

Ref. No.	Part No.	Description	Remark
R709	1-259-995-11	CARBON MELF 1K	2% 1/8W
△R710	1-202-937-41	FUSIBLE 10	5% 1/2W
△R711	1-202-937-41	FUSIBLE 10	5% 1/2W
R712	1-260-002-11	CARBON MELF 3.3K	2% 1/8W
R713	1-260-008-11	CARBON MELF 10K	2% 1/8W
R717	1-260-020-11	CARBON MELF 100K	2% 1/8W
R718	1-260-008-11	CARBON MELF 10K	2% 1/8W
R719	1-260-020-11	CARBON MELF 100K	2% 1/8W
R720	1-260-002-11	CARBON MELF 3.3K	2% 1/8W
R721	1-260-002-11	CARBON MELF 3.3K	2% 1/8W
	1-673-519-11	VOL BIARD	

1-673-513-11 SW L BOARD

< CAPACITOR >

C601	1-163-009-11	CERAMIC CHIP 0.001uF	10% 50V
C609	1-119-847-11	ELECT 2.2uF	20% 100V

< CONNECTOR >

CN601	1-691-769-11	PLUG (MICRO CONNECTOR) 7P
CN602	1-691-768-11	PLUG (MICRO CONNECTOR) 6P

< DIODE >

D605	8-719-800-76	DIODE 1SS226
------	--------------	--------------

< TRANSISTOR >

Q601	8-729-047-96	TRANSISTOR 2SC3645-S
------	--------------	----------------------

< RESISTOR >

R602	1-260-008-11	CARBON MELF 10K	2% 1/8W
R608	1-259-978-11	CARBON MELF 39	2% 1/8W
R609	1-260-008-11	CARBON MELF 10K	2% 1/8W

< SWITCH >

S601	1-771-566-11	SWITCH, ROTARY (INPUT SELECTOR)
------	--------------	---------------------------------

1-673-518-11 SW P BOARD

< CAPACITOR >

C602	1-163-009-11	CERAMIC CHIP 0.001uF	10% 50V
C603	1-163-009-11	CERAMIC CHIP 0.001uF	10% 50V
C604	1-163-009-11	CERAMIC CHIP 0.001uF	10% 50V

< CONNECTOR >

CN606	1-691-770-11	PLUG (MICRO CONNECTOR) 8P
CN607	1-691-768-11	PLUG (MICRO CONNECTOR) 6P

< DIODE >

D606	8-719-025-19	DIODE 02CZ2.2-TE85L
D607	8-719-043-82	DIODE 02CZ5.1Y-TE85L

Ref. No.	Part No.	Description	Remark
		< RESISTOR >	

R601	1-260-008-11	CARBON MELF 10K	2% 1/8W
R603	1-260-008-11	CARBON MELF 10K	2% 1/8W
R604	1-260-008-11	CARBON MELF 10K	2% 1/8W

< SWITCH >

S602	1-771-567-11	SWITCH, PUSH (3 KEY) (TAPE MONITOR, TAPE 1/2, DIRECT)
------	--------------	--

1-673-519-11 VOL BOARD

< CONNECTOR >

CN301	1-691-770-11	PLUG (MICRO CONNECTOR) 8P
-------	--------------	---------------------------

< VARIABLE RESISTOR >

RV301	1-225-742-11	RES, VAR, CARBON 20K/20K
-------	--------------	--------------------------

MISCELLANEOUS

6	1-580-375-41	INLET 3P
△T1	1-433-981-11	TRANSFORMER, POWER (EXCEPT US,CND)
△T1	1-433-982-11	TRANSFORMER, POWER (US,CND)

ACCESSORIES & PACKING MATERIALS

1-506-411-21	ADAPTOR, AC PLUG 3P-2P(US,CND)
1-551-631-22	CORD, POWER (EXCEPT US,CND)
1-551-812-11	CORD, POWER (US,CND)
1-558-271-11	CORD, CONNECTION (AUDIO, 108cm)
3-866-956-11	MANUAL, INSTRUCTION (ENGLISH,FRENCH)

3-866-956-21	MANUAL, INSTRUCTION (GERMAN,SPANISH, DUTCH,SWEDISH,ITALIAN,PORTUGUESE)(EXCEPT US,CND)
--------------	--

HARDWARE LIST

#1	7-621-775-10	SCREW +B 2.6X4
#2	7-682-566-04	SCREW +B 4X20
#2	7-682-567-09	SCREW +B 4X25 (US,CND)
#3	7-682-549-04	SCREW +B 3X10
#4	7-621-770-87	SCREW +B 2.6X5

#5	7-621-770-XX	SCREW +B 2.6X8
#6	7-682-571-09	+B 4X45 (EXCEPT US,CND)
#7	7-685-871-09	SCREW +BVTT 3X6 (S)
#8	7-682-550-09	SCREW +B 3X12
#9	7-682-962-01	+PSW 4X10

#10	7-683-255-58	SET SCREW 5X6 HEXAGON SOCKET
-----	--------------	------------------------------

The components identified by mark △ or dotted line with mark △ are critical for safety.
Replace only with part number specified.

Les composants identifiés par une marque △ sont critiques pour la sécurité.
Ne les remplacer que par une pièce portant le numéro spécifié.