

# TA-E1000ESD

## SERVICE MANUAL

US Model  
Canadian Model  
AEP Model  
UK Model  
E Model

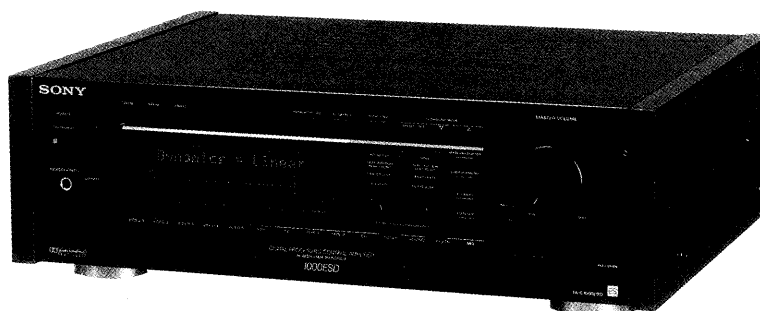

### SPECIFICATIONS

#### Amplifier section

Frequency response (Parametric EQ, Dynamics, Surround all off)	Other than PHONO	FRONT 1.2, REAR, CENTER (at WIDE)	10 Hz - 20 kHz $\pm 0.1$ dB
		SUBWOOFER	Cut off 80 Hz, -18 dB/oct
	PHONO	VIDEO 1-3 AUDIO OUT, TAPE 1.2 REC OUT	20 Hz - 20 kHz $\pm 0.2$ dB
Input sensitivity and input impedance	PHONO		2 mV 50 k $\Omega$
	TUNER, CD, TAPE 1.2, VIDEO 1-5, VDP, TV		150 mV 50 k $\Omega$
	DIGITAL	OPTICAL 1.2	-
		COAXIAL	0.5 V <sub>p-p</sub> $\pm 20\%$ 75 $\Omega$
S/N	PHONO		Front 84 dB, rear 84 dB (A)
	TUNER, CD, TAPE 1.2, VIDEO 1-5, VDP, TV		Front: 95 dB, rear: 95 dB (A)
	DIGITAL (OPTICAL 1.2, COAXIAL)		Front: 110 dB, rear: 99 dB (A)
Remaining noise			Below 10 $\mu$ V (A)
Output voltage and output impedance	VIDEO 1-3 AUDIO OUT, TAPE 1.2 REC OUT		150 mV 1 k $\Omega$
	FRONT 1.2, REAR CENTER, SUBWOOFER		1.5 V
	DIGITAL (OPTICAL 2)		-
	Headphones		15 mV (at 8 ohms): accepts low and high impedance headphones
Total harmonic distortion	ANALOG IN		Front: below 0.004% at 1 kHz
	DIGITAL IN		Front: below 0.003% at 1 kHz

DIGITAL PROCESSING CONTROL AMPLIFIER  
**SONY**<sup>®</sup>



## Video section

Video input sensitivity and input impedance	VIDEO IN	VIDEO 1-5, VDP, TV	1 Vp-p 75 Ω
	S VIDEO IN	VIDEO 1, 2, 5	Luminance: 1 Vp-p 75 Ω; chroma: 0.286 Vp-p 75 Ω
Video output voltage and output impedance	VIDEO OUT	VIDEO 1-3, MONITOR 1, 2	1 Vp-p 75 Ω
	S VIDEO OUT	VIDEO 1, 2 MONITOR	Luminance: 1 Vp-p 75 Ω; chroma: 0.286 Vp-p 75 Ω

## Digital signal processor section

Parametric EQ	Band		3-band
	Center frequency		18 Hz - 20 kHz
	Level		±12 dB. 0.1 dB step
	Slope (Q)		4-step selectable (0.7, 1.4, 3.7, 20)
Dynamics	Compressor		9-step adjustable
	Expander		9-step adjustable
Surround	Main parameter	Room size	0.5 - 2.0
		Wall	0.5 - 2.0
		Seat position	F50 - 0 - R50, L50 - 0 - R50
	Sub parameter	Early reflection time	1 - 255 ms
		Early reflection level	0 - 100%
		Reverberation time	0.3 - 5.0 sec.
		Reverberation density	Low, Mid, High
		Spread	0.5 - 2.0
		Effect level	0 - 100%
		Both delay time	15.0 - 30.0 ms
Each delay time	15.0 - 30.0 ms		

## A/D, D/A converter section

A/D converter	Type	High Density Linear Converter
	Sampling frequency	48 kHz
D/A converter	Front	18-bit linear 8 fs × 2
	Rear	16-bit linear 4 fs × 1
	Sampling frequency	32 kHz, 44.1 kHz, 48 kHz

## General

Power requirements	US, Canadian: 120V AC 60Hz AEP: 220V AC (or 240V AC adjustable by authorized Sony personnel), 50/60Hz UK: 240V AC (or 220V AC adjustable by authorized Sony personnel), 50/60Hz E: 120V, 220V, and 240V AC adjustable, 50/60Hz
Power consumption	35 watts
AC outlets	Three switched, total 700 (US, Canadian, E), 540 (AEP, UK) watts; one unswitched 300 watts
Dimensions (w/h/d)	470 × 150 × 360 mm (18 1/2 × 6 × 14 1/4 in)
Weight	8.0 kg (17 lb 11 oz)
Supplied accessories	Programmable remote commander RM-P1000 (1) Sony batteries SUM-3 (NS) (2), Connection cord (1), Screws (4)

Design and specifications subject to change without notice.

## SAFETY CHECK-OUT

After correcting the original service problem, perform the following safety check before releasing the set to the customer:

Check the antenna terminals, metal trim, "metallized" knobs, screws, and all other exposed metal parts for AC leakage. Check leakage as described below.

### LEAKAGE TEST

The AC leakage from any exposed metal part to earth ground and from all exposed metal parts to any exposed metal part having a return to chassis, must not exceed 0.5 mA (500 microamperes). Leakage current can be measured by any one of three methods.

1. A commercial leakage tester, such as the Simpson 229 or RCA WT-540A. Follow the manufacturers' instructions to use these instruments.
2. A battery-operated AC milliammeter. The Data Precision 245 digital multimeter is suitable for this job.
3. Measuring the voltage drop across a resistor by means of a VOM or battery-operated AC voltmeter. The "limit" indication is 0.75 V, so analog meters must have an accurate low-voltage scale. The Simpson 250 and Sanwa SH-63Trd are examples of a passive VOM that is suitable. Nearly all battery operated digital multimeters that have a 2 V AC range are suitable. (See Fig. A)

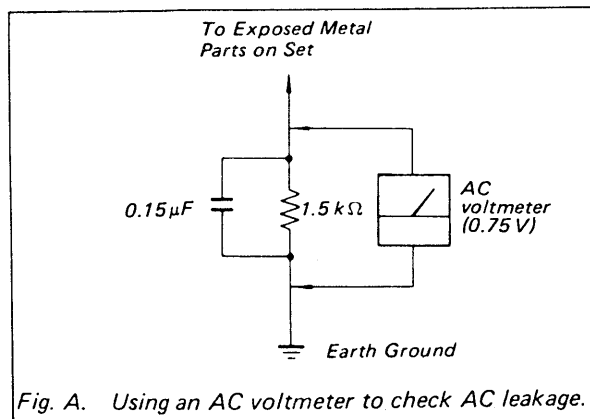

## MODEL IDENTIFICATION

—Specification Label—

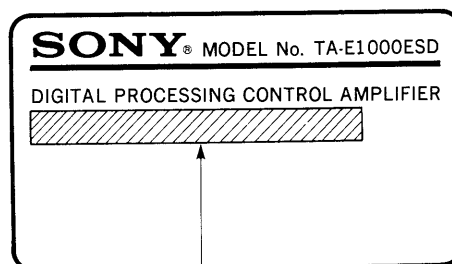

US, Canadian Model: AC: 120V 60Hz 35W  
 AEP, West Germany (WG) Model: AC: 220V ~ 50/60Hz  
 UK Model: AC: 240V ~ 50/60Hz  
 E Model: AC: 120/220/240V ~ 50/60Hz 36W

### SAFETY-RELATED COMPONENT WARNING!!

COMPONENTS IDENTIFIED BY MARK  $\triangle$  OR DOTTED LINE WITH MARK  $\triangle$  ON THE SCHEMATIC DIAGRAMS AND IN THE PARTS LIST ARE CRITICAL TO SAFE OPERATION. REPLACE THESE COMPONENTS WITH SONY PARTS WHOSE PART NUMBERS APPEAR AS SHOWN IN THIS MANUAL OR IN SUPPLEMENTS PUBLISHED BY SONY.

### ATTENTION AU COMPOSANT AYANT RAPPORT À LA SÉCURITÉ!

LES COMPOSANTS IDENTIFIÉS PAR UNE MARQUE  $\triangle$  SUR LES DIAGRAMMES SCHÉMATIQUES ET LA LISTE DES PIÈCES SONT CRITIQUES POUR LA SÉCURITÉ DE FONCTIONNEMENT. NE REMPLACER CES COMPOSANTS QUE PAR DES PIÈCES SONY DONT LES NUMÉROS SONT DONNÉS DANS CE MANUEL OU DANS LES SUPPLÉMENTS PUBLIÉS PAR SONY.

TABLE OF CONTENTS

<u>Section</u>	<u>Title</u>	<u>Page</u>	<u>Section</u>	<u>Title</u>	<u>Page</u>
<b>1. GENERAL</b>			<b>4. EXPLODED VIEWS</b>		
1-1.	Function of Controls .....	5	4-1.	Chassis and Main Board Assembly .....	33
<b>2. ELECTRICAL ADJUSTMENT</b> .....		7	4-2.	Front Panel Assembly .....	35
<b>3. DIAGRAMS</b>			<b>5. ELECTRICAL PARTS LIST</b> .....		36
3-1.	Circuit Boards Location .....	7			
3-2.	Printed Wiring Board —Analog Section— .....	8			
3-3.	Schematic Diagram —Analog Section— .....	11			
3-4.	Schematic Diagram —Digital Section— .....	15			
3-5.	Printed Wiring Board —Digital Section— .....	19			
3-6.	Schematic Diagram —Video/Display Section— .....	23			
3-7.	Printed Wiring Board —Video/Display Section— .....	27			
3-8.	Semiconductor Lead Layouts .....	32			



# SECTION 1 GENERAL

## 1-1. FUNCTIONS OF CONTROLS

### Front Panel

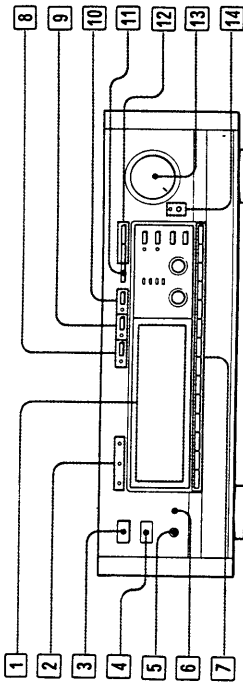

- 1 Display window**  
Selects the factory-preset program and the user program.
- 2 Sampling frequency indicators**  
When a digital signal is being input correctly, an indicator of the sampling frequency glows (44kHz for compact disc, etc.).
- 3 POWER switch**  
Press to turn on the unit. Press again to turn off.
- 4 Remote control sensor**
- 5 DIMMER button**  
Dims the brightness of the display window. Two levels of brightness can be selected.
- 6 HEADPHONES jack**  
Accepts the stereo phone plug of headphones. The jack outputs the sound of front speakers only. To listen to the program source only with the headphones, turn off the power amplifiers as the unit does not turn off the line output when the headphone plug is inserted.
- 7 Input function buttons**  
Selects the desired program source.
- 8 PARAMETRIC EQ button and indicator**  
Turns on and off the parametric equalizer. When the parametric equalizer is on, the indicator glows.
- 9 DYNAMICS button and indicator**  
Turns on and off the dynamics function. When the dynamics function is on, the indicator glows.
- 10 SURROUND button and indicator**  
Turns on and off the surround function. When the surround function is on, the indicator glows.
- 11 PRESET/USER select button**  
Selects the factory-preset program and the user program.
- 12 SOUNDFIELD PROGRAM buttons**  
Selects the desired program number.
- 13 MASTER VOLUME knob**  
Controls the audio level from LINE OUT and HEADPHONES jacks.
- 14 MUTING button and indicator**  
Press the button to mute the sound. Press again to resume the sound.
- 15 MAIN PARAMETER button and indicators**  
Selects the pair of main parameters to be set. The indicator glows when the main parameters can be set.
- 16 SUB PARAMETER button and indicator**  
Selects the sub parameter to be set. The indicator glows when the displayed sub parameter can be set.
- 17 EQ BAND select button**  
Selects the desired band of the parametric equalizer.
- 18 EQ SLOPE select button**  
Selects the desired slope (bandwidth) of the parametric equalizer.
- 19 DIGITAL PROCESSING CONTROL knobs and indicators**  
Set the parameters.

### Behind the panel

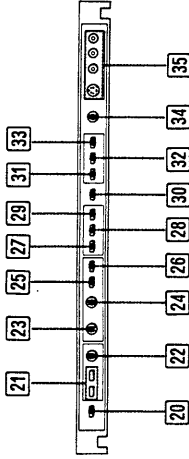

- 20 DISPLAY MODE button**  
Selects the component of the display window as follows:
  - Displays all information.
  - Displays only the input function.
  - Turns off the display and all indicators except the volume indicator.
- 21 DIGITAL input level buttons**  
Adjust the input level of digital inputs. Press + until OVER appears in the display, then press - until OVER goes off.
- 22 ANALOG input level knob**  
Adjusts the input level of analog inputs. Turn the knob clockwise until OVER appears in the display, then turn the knob counterclockwise until OVER goes off.
- 23 INPUT LEVEL control knob**  
Adjusts the input level of Dolby surround program sources.
- 24 INPUT BALANCE control knob**  
Adjusts the input balance of Dolby surround program sources.
- 25 PRO LOGIC MODE button**  
Selects the operation mode of Dolby Pro Logic surround function.
- 26 TEST TONE button**  
Turns on and off the test tone to adjust the balance among front, rear, and center speakers.
- 27 MEMORY button**  
Press when storing the parameter settings, etc.
- 28 ENTER button**  
Stores parameter settings in the unit.
- 29 CLEAR button**  
Clears the assigned digital input to a input function button.
- 30 CHARACTER button**  
Labels to a input function button.
- 31 EFFECT REC button**  
Outputs analog REC-OUT signals with digital sound effects. This function does not operate for digital REC-OUT signals.
- 32 SET button**  
Sets the desired program source for recording while you listen to/watch another program source.
- 33 CHECK button**  
Displays the program source to be recorded set by the SET button.
- 34 BALANCE control knob**  
Adjusts the balance between left and right front speakers. Generally, set the knob at the center position.
- 35 VIDEO 5 INPUT jacks**  
Accepts S-video/video and audio input signals.

## Programmable System Commander RM-P1000

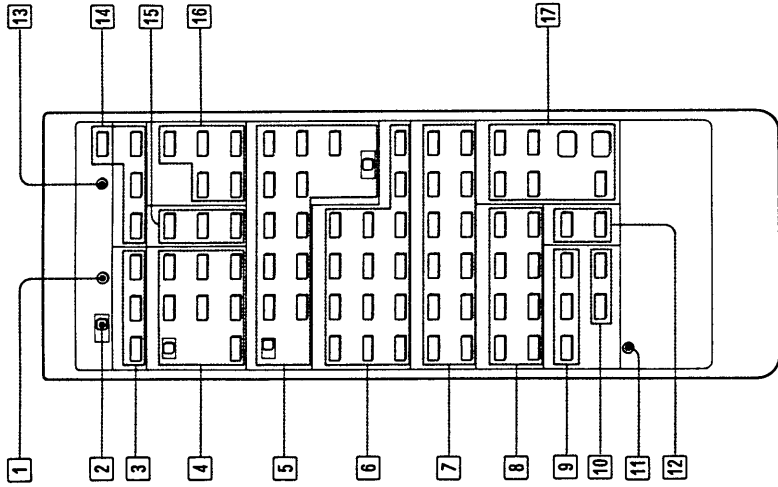

The RM-P1000 can "learn" various functions of other remote commanders which use infrared rays. When the mode selector is set to SONY STD(Sony standard), buttons on the RM-P1000 can be used to perform the functions below:

- 1 **LEARN Indicator**
  - 2 **Mode selector**  
SONY STD: To operate the commander on Sony standard.  
USER STD: To use the learned functions.  
LEARN: To learn other functions.
  - 3 **AC OUTLET CONTROLLER buttons**  
These buttons does not operate with this unit.
  - 4 **CD player/video disc player operation buttons**  
CD/VDP  
▶ : Play  
|| : Pause  
■ : Stop  
◀▶ : AMS(Automatic Music Sensor)  
◀▶ : Search
  - 5 **TAPE/VTR operation buttons**  
TAPE/VTR : Selects the unit to be operated.  
▶ : Play  
|| : Pause  
■ : Stop  
◀▶ : Rewind  
▶▶ : Fast forward  
● : Recording(Press both buttons for recording.)
- Following buttons can be used when the TAPE/VTR selector is set to VTR.
- DUAL : Selects bilingual programs
  - ANT TV/VTR : Selects output signal from the antenna terminal on the VCR.
  - CH +/- : Selects a higher or lower preset channel.
  - VTR selector : Selects VTR 1,2, or 3.
- 6 **Input function buttons**
  - 7 **Soundfield program buttons**
  - 8 **Parameter control buttons**  
MAIN PARAMETER select button  
SUB PARAMETER select button  
EQUALIZER BAND select button  
EQUALIZER SLOPE select button  
DIGITAL PROCESSING CONTROL buttons  
Work as DIGITAL PROCESSING CONTROL knobs on the unit.
  - 9 **Digital sound processing buttons**  
PARAMETRIC EQ on/off button  
DYNAMICS on/off button  
SURROUND on/off button
  - 10 **DISPLAY buttons**  
DISPLAY MODE button  
DIMMER button
  - 11 **RESET button**
  - 12 **Dolby surround buttons**  
PRO LOGIC MODE button  
TEST TONE button
  - 13 **PROGRAM CLEAR button**  
Clears all programmed signals.
  - 14 **POWER buttons**  
POWER : Turns on and off the TA-E1000ESD.  
TV POWER : Turns on and off the TV.  
VTR POWER : Turns on and off the VCR selected by the VTR selector switch. (usable only when the TAPE/VTR selector is set to VTR).  
VDP POWER: Turns on and off the video disc player.
  - 15 **Tuner operation buttons**  
BAND : Selects the frequency band.  
PRESET +/- : Selects a higher or lower preset number.
  - 16 **TV operation button**  
TV/VIDEO : Selects the input to the TV  
VOL +/- buttons: Adjusts the volume.  
CH +/- buttons : Selects a higher or lower preset channel.
  - 17 **Volume control buttons**  
MASTER VOL +/- : Adjusts the level from LINE OUT and HEADPHONES jacks.  
REAR VOL +/- : Adjusts the level of the rear speakers.  
CENTER VOL +/- : Adjusts the level of the center speaker.  
MUTING : Mutes the output signal.

## Installing the batteries

**To avoid damage caused by battery leakage and corrosion**  
When the commander will not be used for a long time, remove the batteries.

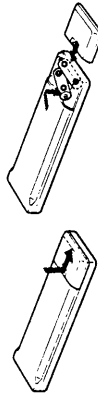

## SECTION 2 ELECTRICAL ADJUSTMENT

## SECTION 3 DIAGRAMS

### DISTORTION ADJUSTMENT

**Note:** The adjustment is required CD player having COAXIAL OUT (ex. CDP-552ESD or CDP-650ESD).

#### Setting

- SURROUND switch (S1003): OFF
- DYNAMICS switch (S1004): OFF
- PARAMETRIC EQ switch (S1005): OFF
- DIGITAL switch (S1012): COAXIAL
- MASTER VOLUME knob (RV801): MAX

#### Connection

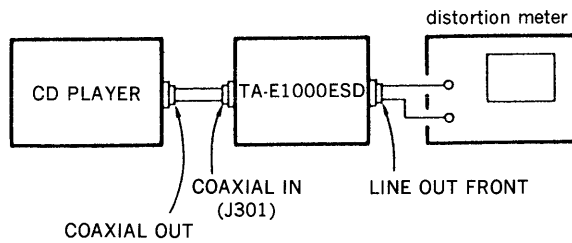

#### Procedure

- (1) Playback the second selection ( $f=1\text{kHz}$ ,  $f_s=44.1\text{kHz}$  0dB) of test disc YEDS-18.
- (2) Adjust RV601 (L-CH), RV651 (R-CH) on the DIGITAL board for minimum reading on the distortion meter.

**Adjustment Limits:** About 0.003%

#### Adjustment Location:

DIGITAL BOARD (COMPONENT SIDE)

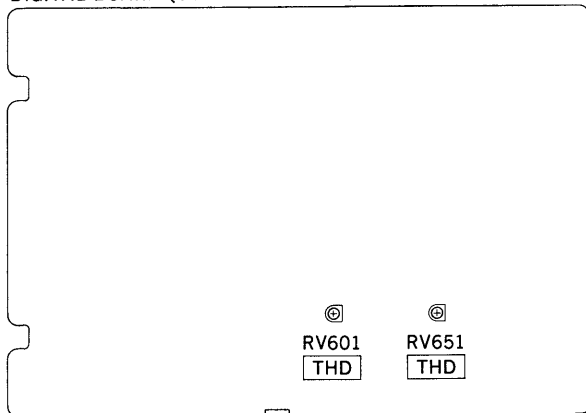

### 3-1. CIRCUIT BOARDS LOCATION

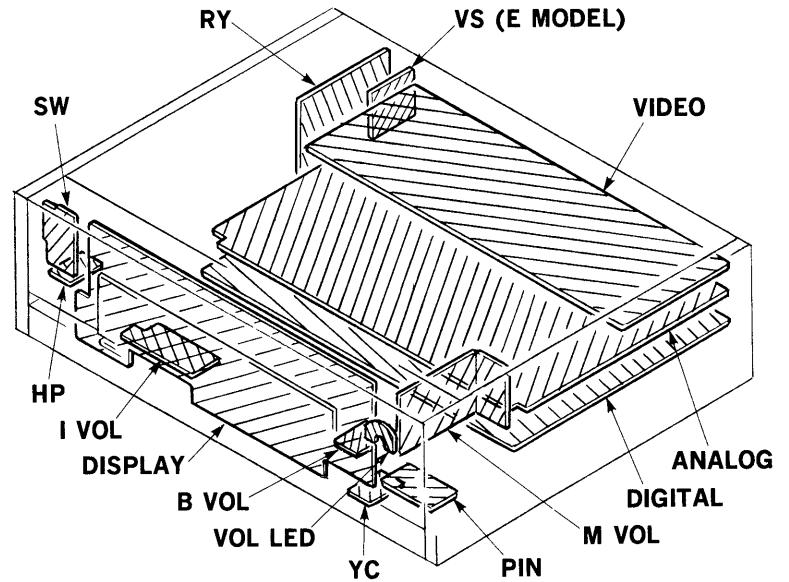





3-3. SCHEMATIC DIAGRAM —ANALOG SECTION—

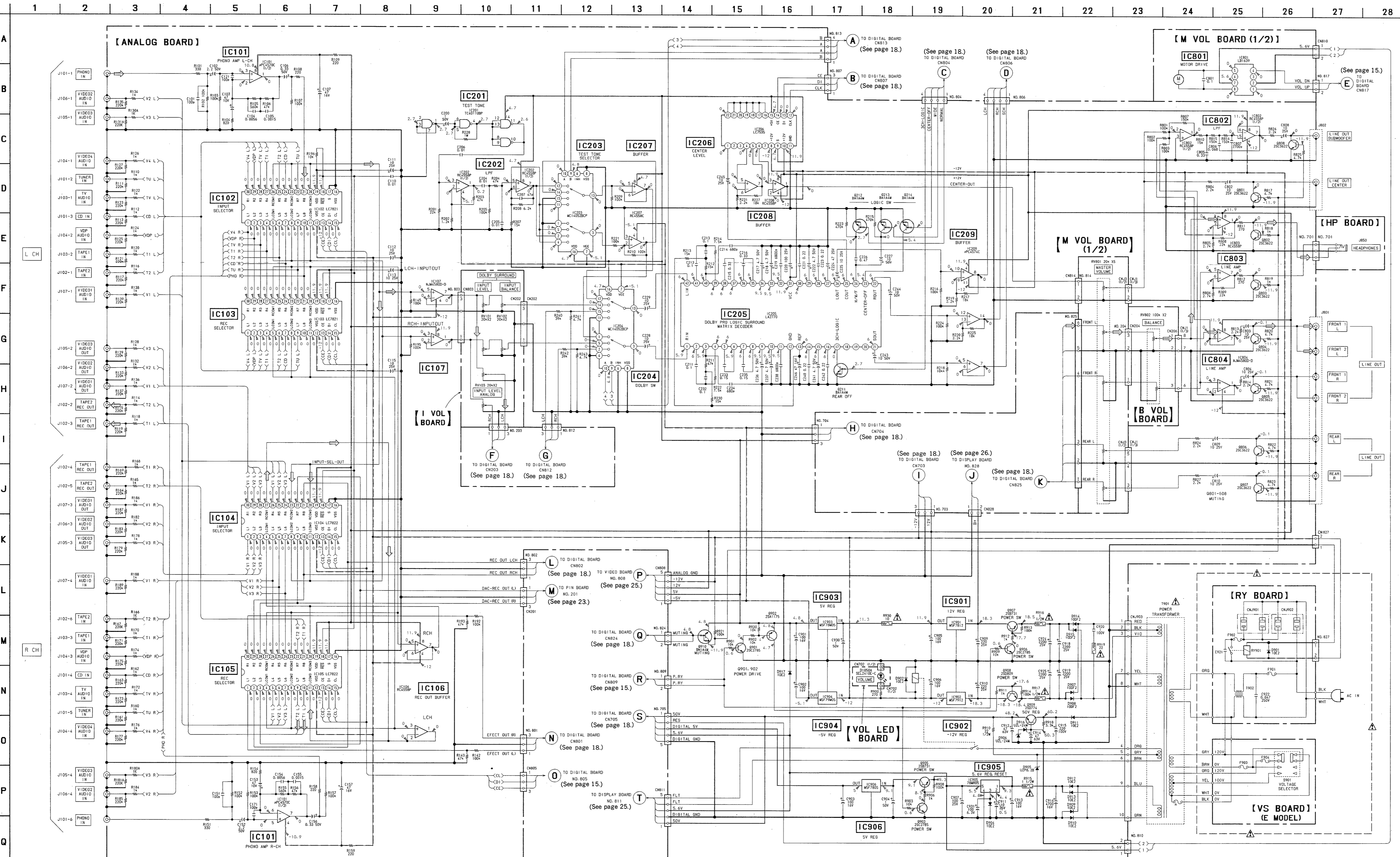

**Semiconductor Location**

Ref. No.	Location	Ref. No.	Location
D901	G-22	Q806	B-12
D902	I-11	Q807	B-13
D904	K-14	Q808	B-14
D905	I-14	Q901	G-9
D906	I-13	Q902	G-9
D907	G-14	Q903	J-13
D908	G-14	Q905	J-13
D909	J-14	Q906	G-12
D910	J-14	Q907	F-12
D911	H-14	Q908	H-12
D912	I-14	Q909	H-13
D913	I-14	Q910	C-12
D914	F-14		
D915	F-14		
D916	I-13		
D917	J-10		
D1050A	E-16		

IC101	C-2
IC102	C-5
IC103	D-5
IC104	C-10
IC105	D-10
IC106	E-8
IC107	E-7
IC201	J-3
IC202	J-4
IC203	J-5
IC204	J-8
IC205	H-6
IC206	G-3
IC207	J-6
IC208	H-3
IC209	H-4
IC801	B-23
IC802	D-14
IC803	E-13
IC804	D-13
IC901	H-11
IC902	I-12
IC903	H-10
IC904	H-11
IC905	J-13
IC906	J-12

Q211	H-5
Q212	G-5
Q213	G-5
Q214	G-4
Q801	B-13
Q802	F-13
Q803	F-13
Q804	B-12
Q805	B-12

**IC Block Diagram**

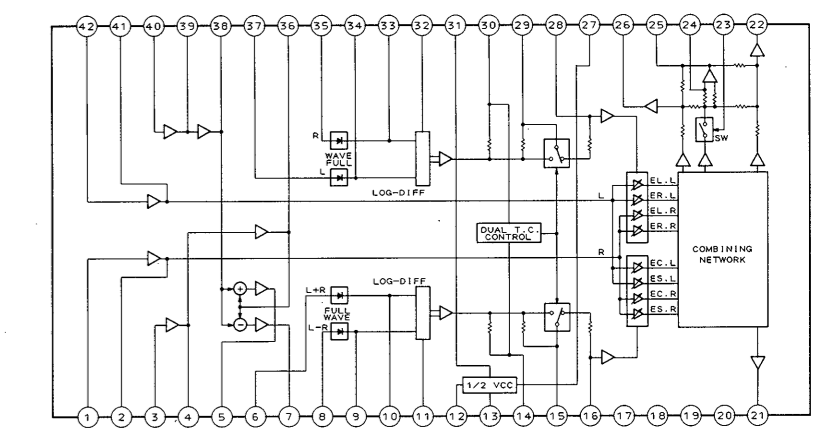

**Note on Schematic Diagram:**

- All capacitors are in  $\mu\text{F}$  unless otherwise noted.  $\text{pF}$ :  $\mu\text{F}$  50WV or less are not indicated except for electrolytics and tantalums.
- All resistors are in  $\Omega$  and  $\frac{1}{4}\text{W}$  or less unless otherwise specified.
- $\text{NF}$ : nonflammable resistor.

**Note:** The components identified by mark **A** or dotted are critical for safety. Replace only with part number specified.

**Note:** Les composants identifiés par une marque **A** ou des points sont critiques pour la sécurité. Ne les remplacer que par une pièce portant le numéro spécifié.

- : B+ Line
- : B- Line
- : adjustment for repair.
- Voltagés are dc with respect to ground under no-signal conditions.
- no mark: ( )
- ( )
- Voltagés are taken with a VOM (input Impedance 10M $\Omega$ ).
- Signal path.
- PHONO
- Marked \* is not able to measure the voltage of its position.

**DIFFERENTIAL LIST**

	US	CND	E	UK	JEP	WG
C921	0.01/400V	0.01/400V	0.001/400V	0.001/400V	0.001/400V	0.001/400V
CM901	○	○	×	×	×	×
CM902	○	○	×	×	×	×
FP91	○	○	BUS BAR	○	○	○
FP92	BUS BAR	BUS BAR	BUS BAR	BUS BAR	○	○

• CND: Canadian  
• WG: West Germany

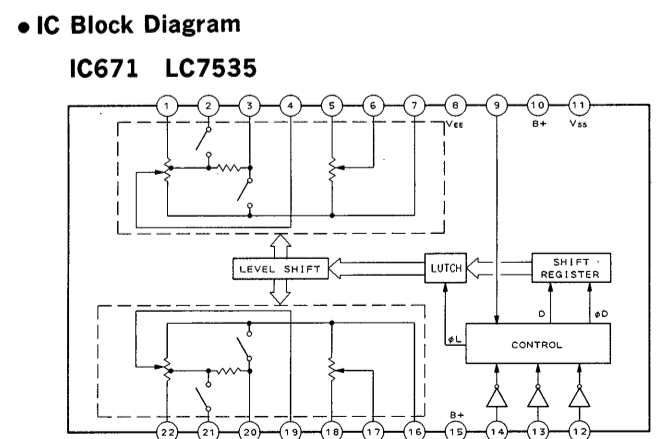
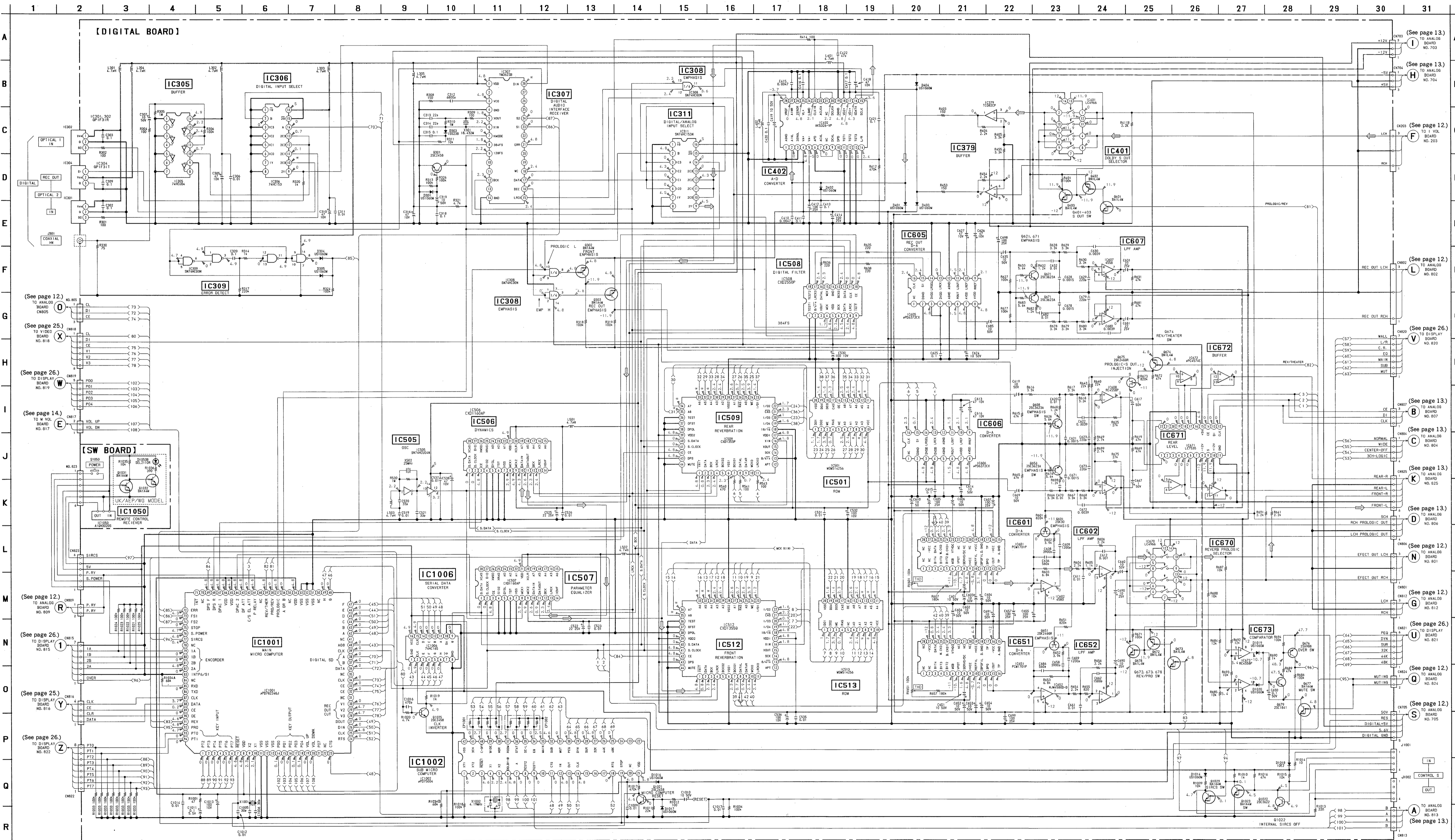



3-5. PRINTED WIRING BOARD —DIGITAL SECTION—

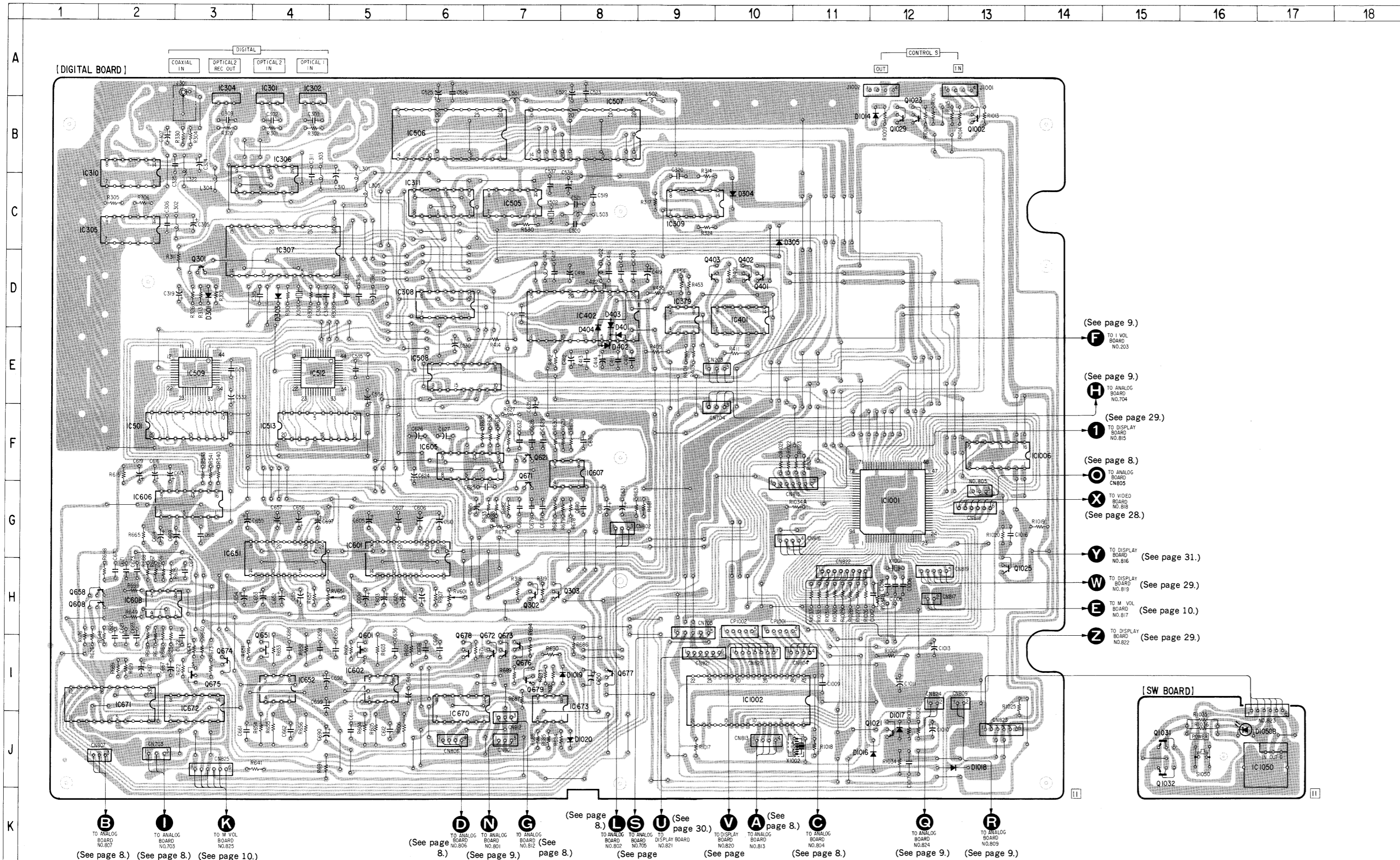

• Semiconductor Location.

Ref. No.	Location	Ref. No.	Location
D301	D-3	Q401	D-10
D303	D-4	Q402	D-10
D304	C-10	Q403	D-9
D305	C-10	Q601	I-5
D1014	B-12	Q608	H-1
D1015	B-12	Q621	F-7
D1016	J-12	Q651	I-4
D1017	J-12	Q658	H-1
D1018	J-13	Q671	G-7
D1019	I-8	Q672	I-7
D1020	J-8	Q673	I-7
D1050B	J-17	Q674	I-3
		Q675	I-3
		Q676	I-7
IC301	A-4	Q677	I-8
IC302	A-4	Q678	I-6
IC304	A-3	Q679	I-7
IC305	C-2	Q1021	J-12
IC306	B-4	Q1022	B-13
IC307	C-4	Q1023	B-12
IC308	D-6	Q1025	H-13
IC309	C-9	Q1029	B-12
IC310	B-2	Q1031	J-16
IC311	C-6	Q1032	J-16
IC379	D-9		
IC401	D-10		
IC402	D-8		
IC501	F-2		
IC505	C-7		
IC506	B-6		
IC507	B-8		
IC508	E-6		
IC509	E-3		
IC512	E-4		
IC513	F-4		
IC601	G-5		
IC602	I-5		
IC605	F-6		
IC606	G-2		
IC607	F-8		
IC608	H-2		
IC651	G-4		
IC652	I-4		
IC670	J-6		
IC671	I-2		
IC672	I-3		
IC673	I-8		
IC1001	G-12		
IC1002	I-10		
IC1006	F-14		
IC1050	J-17		
Q301	D-3		
Q302	H-7		
Q303	H-8		

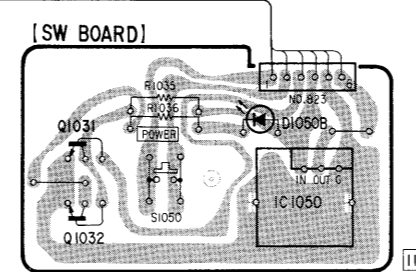





3-6. SCHEMATIC DIAGRAM —VIDEO/DISPLAY SECTION— Refer to page 14 for note.

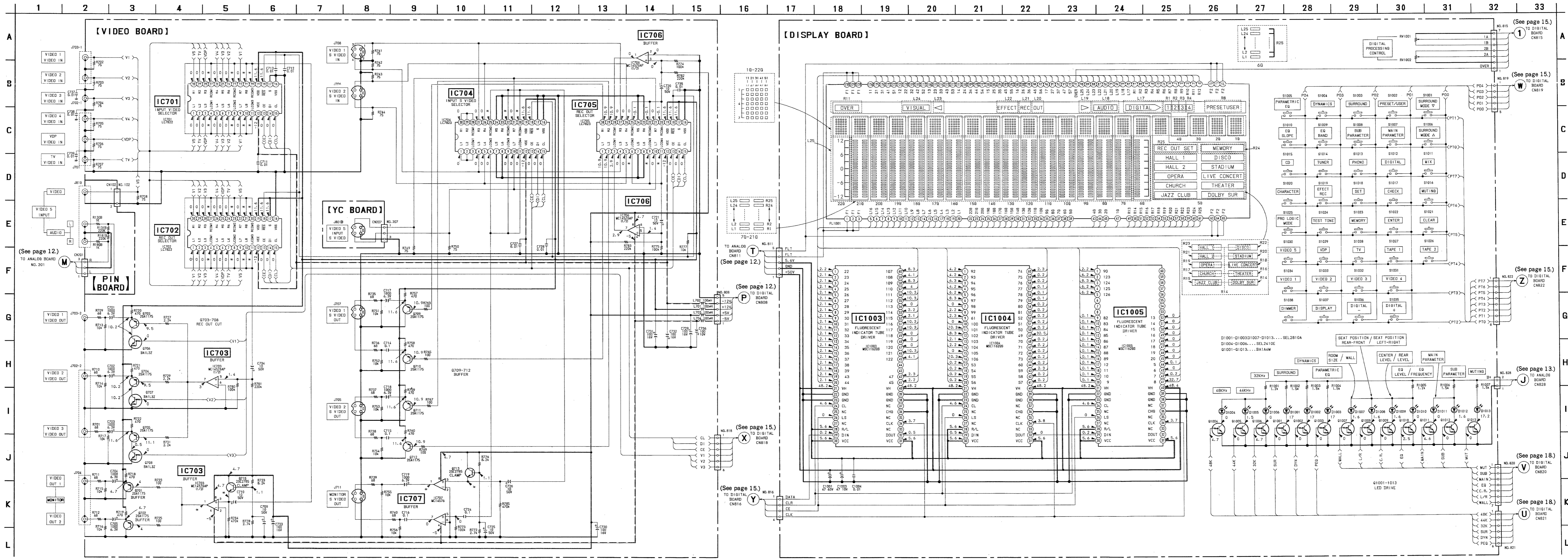



3-7. PRINTED WIRING BOARD —VIDEO/DISPLAY SECTION—

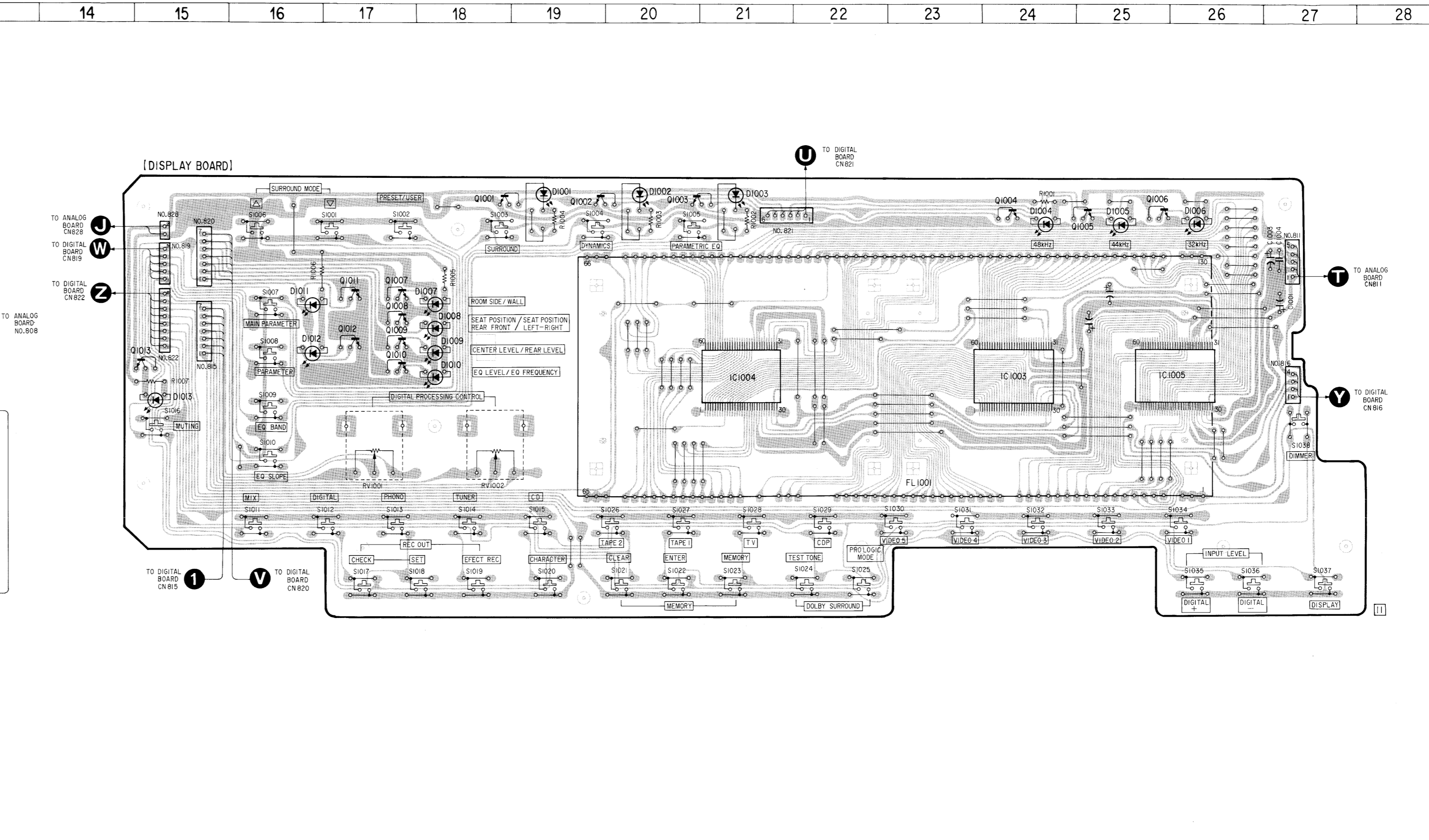
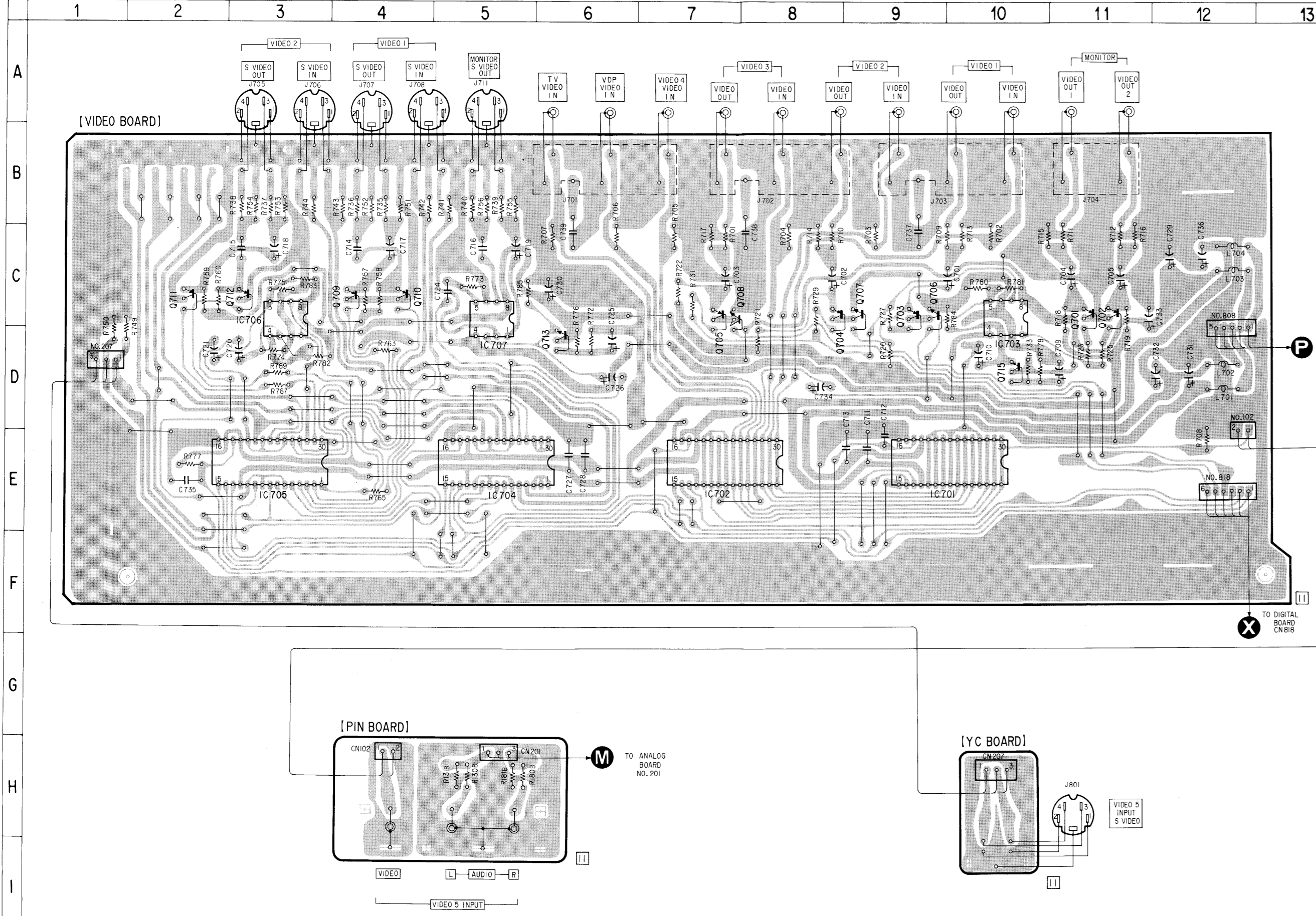

• Semiconductor Location.

Ref. No.	Location
D1001	B-19
D1002	B-20
D1003	B-21
D1004	C-24
D1005	C-25
D1006	C-26
D1007	C-18
D1008	D-18
D1009	D-18
D1010	D-18
D1011	D-16
D1012	D-16
D1013	D-15
IC701	E-9
IC702	E-7
IC703	D-10
IC704	E-5
IC705	E-3
IC706	C-3
IC707	D-5
IC1003	D-24
IC1004	D-21
IC1005	D-26
Q701	C-11
Q702	C-11
Q703	C-9
Q704	C-8
Q705	C-7
Q706	C-9
Q707	C-9
Q708	C-7
Q709	C-4
Q710	C-2
Q711	C-2
Q712	C-3
Q713	D-6
Q715	D-10
Q1001	B-18
Q1002	B-19
Q1003	B-20
Q1004	B-24
Q1005	C-25
Q1006	B-25
Q1007	C-17
Q1008	C-17
Q1009	C-17
Q1010	C-17
Q1011	C-17
Q1012	C-17
Q1013	D-15

**SECTION 4  
EXPLODED VIEWS**

**3-8. SEMICONDUCTOR LEAD LAYOUTS**

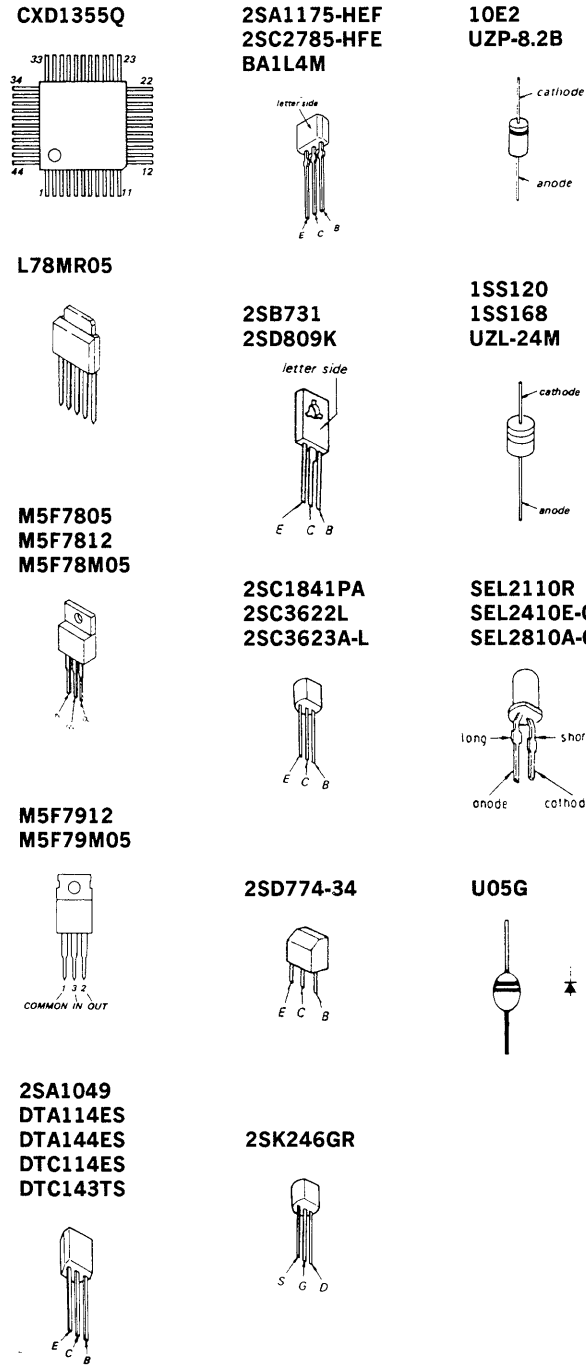

**NOTE:**

- The mechanical parts with no reference number in the exploded views are not supplied.
- The construction parts of an assembled part are indicated with a collation number in the remark column.
- Items marked "★" are not stocked since they are seldom required for routine service. Some delay should be anticipated when ordering these items.
- Due to standardization, parts with part number suffix -XX and -X may be different from the parts specified in the components used on the set.
- Color Indication of Appearance Parts  
Example:  
(RED) ... KNOB, BALANCE (WHITE)  
↑ Cabinet's Color ↑ Parts' Color

The components identified by mark or dotted line with mark are critical for safety. Replace only with part number specified.

Les composants identifiés par une marque sont critiques pour la sécurité. Ne les remplacer que par une pièce portant le numéro spécifié.

- CND : Canadian
- WG : West Germany

**4-1. CHASSIS AND MAIN BOARD ASSEMBLY**

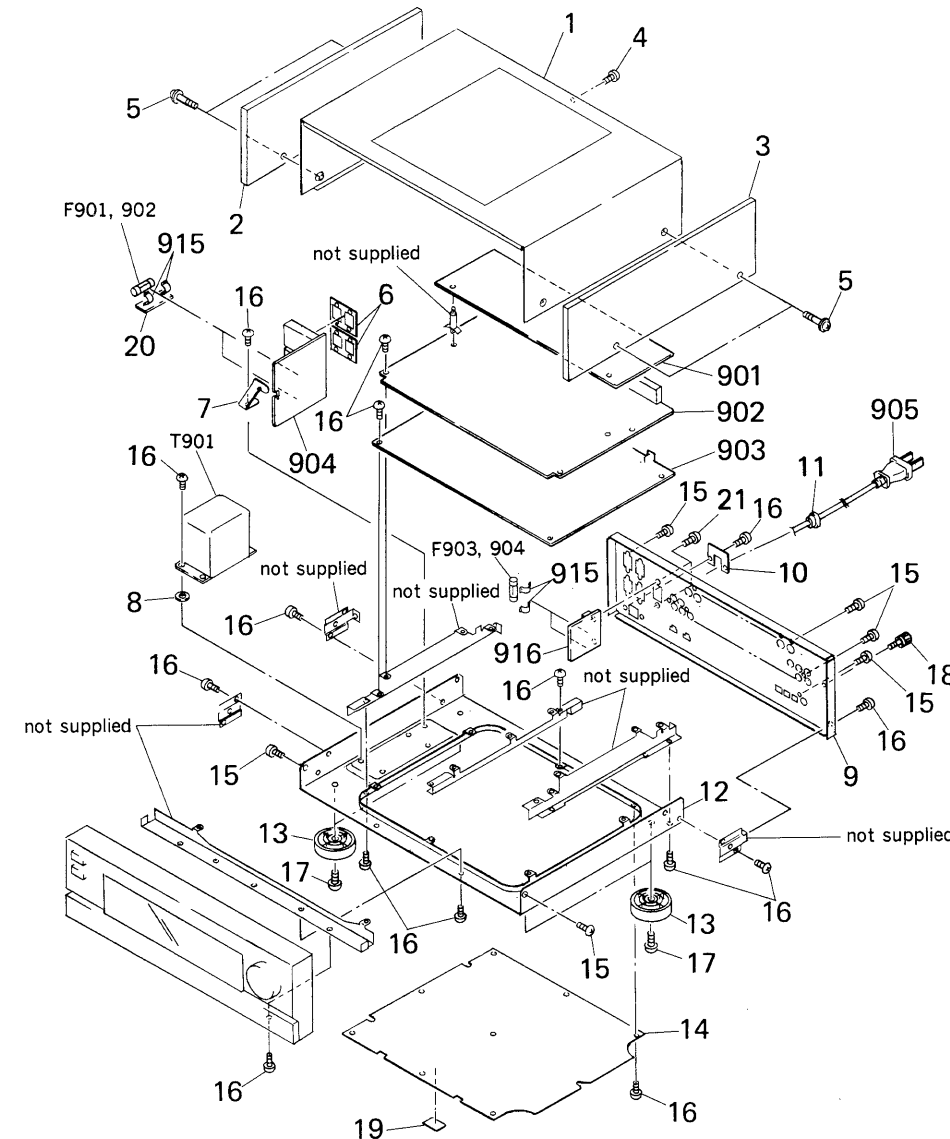

Ref.No	Part No.	Description	Remark
1	4-931-031-11	(E, UK, AEP, WG) ... CASE	
	4-931-031-41	(US, CND) ... CASE	
2	X-4933-401-1	(US, CND, E, AEP) ... PANEL (LEFT) ASSY, SIDE	
	X-4933-407-1	(WG) ... PANEL (LEFT) ASSY, SIDE	
3	X-4933-402-1	(US, CND, E, AEP) ... PANEL (RIGHT) ASSY, SIDE	
	X-4933-408-1	(WG) ... PANEL (RIGHT) ASSY, SIDE	
4	3-704-366-31	SCREW (CASE) (M3X6)	
5	4-933-446-01	SCREW (SIDE PANEL)	
6	*4-931-038-01	(US, CND) ... SPACER (2 GANG)	
7	*3-327-845-01	BRACKET	
8	4-916-751-11	WASHER	
9	*4-933-413-01	(US, CND) ... PANEL, BACK	
	*4-933-413-22	(AEP, WG) ... PANEL, BACK	
	*4-933-413-32	(UK) ... PANEL, BACK	
	*4-933-413-41	(E) ... PANEL, BACK	
10	*4-923-873-01	BRACKET, CORD STOPPER	
11	2-352-626-01	(UK, AEP, WG) ... BUSHING, CORD	
	4-916-783-01	(US, CND) ... BUSHING, CORD	
	*3-703-244-00	(E) ... BUSHING (2104), CORD	
12	*4-908-042-01	CHASSIS, MAIN	
13	X-3304-944-1	FOOT ASSY	
14	*4-908-036-11	PLATE, BOTTOM	
15	7-685-646-79	SCREW + BVTP 3X8 TYPE2 N-S	
16	7-682-547-09	SCREW + BVTT 3X6 (S)	
17	7-685-883-01	SCREW + BVTT 4X12 (S)	
18	3-706-165-00	SCREW	
19	3-703-044-26	(US, CND) ... LABEL, CAUTION	
20	1-560-242-61	(US, CND, E, UK) ... BUS BAR 2P	
21	7-685-134-19	(E) ... SCREW + P 2.6X8	
901	*A-4333-832-A	(US, CND, E, UK, AEP) ... MOUNTED PCB, VIDEO	
	*A-4334-039-A	(WG) ... MOUNTED PCB, VIDEO	
902	*A-4333-833-A	MOUNTED PCB, ANALOG	
	*A-4334-037-A	(E, UK, AEP, WG) ... MOUNTED PCB, ANALOG	
903	*A-4333-834-A	MOUNTED PCB, DIGITAL	
	*A-4334-038-A	(WG) ... MOUNTED PCB, DIGITAL	
904	*1-632-454-11	PC BOARD, RY	
905	1-551-238-00	(AEP, WG) ... CORD, POWER	
	1-555-386-00	(E) ... CORD, POWER	
	1-559-272-11	(UK) ... CORD, POWER	
	1-559-479-11	(US, CND) ... CORD, POWER	
915	*1-533-189-11	HOLDER, FUSE	
916	*1-632-445-11	(E) ... PC BOARD, VS	
F901	1-532-284-00	(UK, AEP, WG) ... FUSE, TIME LAG 0.63A	
	1-532-740-11	(US, CND) ... FUSE, GLASS TUBE (125V 1A)	
F902	1-532-299-00	(AEP, WG) ... FUSE, TIME LAG 5.0A	
F903	1-532-284-00	(E) ... FUSE, TIME-LAG 0.63A	
F904	1-532-284-00	(E) ... FUSE, TIME-LAG 0.63A	
T901	1-449-835-11	(US, CND) ... TRANSFORMER, POWER	
	1-449-881-11	(AEP, WG) ... TRANSFORMER, POWER	
	1-449-882-11	(UK) ... TRANSFORMER, POWER	
	1-449-883-11	(E) ... TRANSFORMER, POWER	

4-2. FRONT PANEL ASSEMBLY

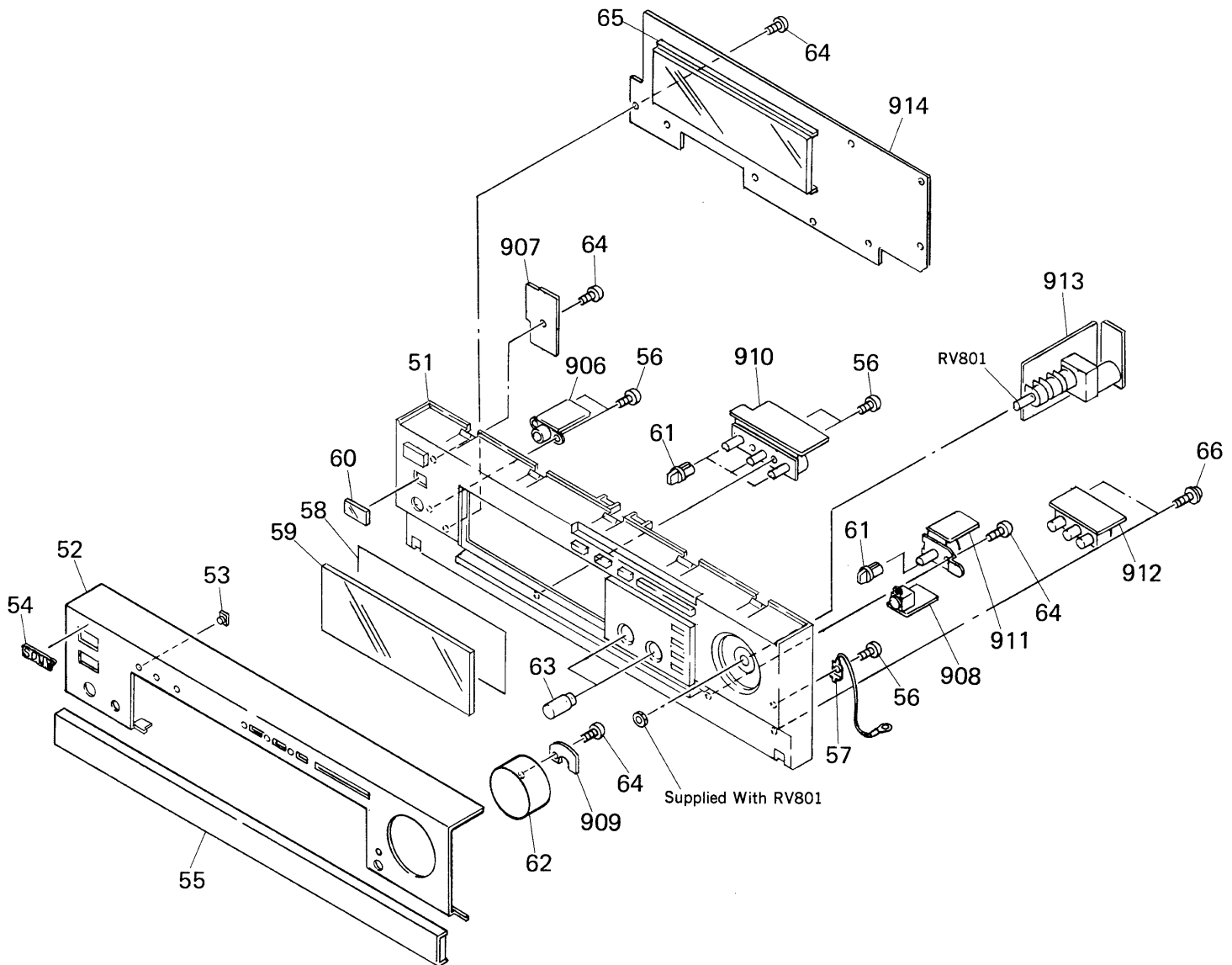

Ref.No	Part No.	Description	Remark
51	X-4933-405-1	PANEL (B) ASSY	
52	4-933-426-01	PANEL, FRONT	
53	4-884-612-11	INDICATOR, EJECT	
54	4-908-884-01	EMBLEM, SONY	
55	A-4323-241-A	(US, CND)....LID ASSY	
55	A-4323-310-A	(E)....LID ASSY	
55	A-4323-312-A	(UK, AEP, WG)....LID ASSY	
56	4-928-635-01	SCREW, +BV (2.6X8) TAPPING	
57	*4-933-433-01	PLATE (F), GROUND	
58	4-933-401-01	FILTER (W)	
59	4-933-411-01	WINDOW, TRANSPARENT	
60	1-933-412-11	(E, UK, AEP, WG)....FILTER (R)	
60	4-933-412-01	(US, CND)....FILTER (R)	
61	4-921-921-01	KNOB (M)	
62	X-4906-828-1	KNOB (47) ASSY	

Ref.No	Part No.	Description	Remark
63	4-933-402-01	KNOB (14-I)	
64	7-685-646-79	SCREW +BVTP 3X8 TYPE2 N-S	
65	4-933-419-01	HOLDER (FL)	
66	7-685-646-79	SCREW	
906	*1-632-446-11	PC BOARD, HP	
907	*1-632-447-11	PC BOARD, SW	
908	*1-632-448-11	PC BOARD, YC	
909	*1-632-449-11	PC BOARD, VOL LED	
910	*1-632-450-11	PC BOARD, I VOL	
911	*1-632-451-11	PC BOARD, B VOL	
912	*1-632-452-11	PC BOARD, PIN	
913	*1-632-455-11	PC BOARD, M VOL	
914	*1-632-453-11	PC BOARD, DISPLAY	
RV801	1-238-747-11	RES, VAR, CARBON 20KX5 (MASTER VOLUME)	

## SECTION 5 ELECTRICAL PARTS LIST

**NOTE:**

- Due to standardization, replacements in the parts list may be different from the parts specified in the diagrams or the components used on the set.
- Items marked "★" are not stocked since they are seldom required for routine service. Some delay should be anticipated when ordering these items.
- If there are two or more same circuits in a set such as a stereophonic machine, only typical circuit parts may be indicated and capacitors and resistors in other same circuits may be omitted.

**CAPACITORS:**

MF:  $\mu$ F, PF:  $\mu$  $\mu$ F.

**RESISTORS**

- All resistors are in ohms.
- F: nonflammable

**COILS**

- MMH: mH, UH:  $\mu$ H

**SEMICONDUCTORS**

In each case, U:  $\mu$ , for example:  
 UA...:  $\mu$ A..., UPA...:  $\mu$ PA...,  
 UPC...:  $\mu$ PC, UPD...:  $\mu$ PD...

The components identified by mark  $\Delta$  or dotted line with mark  $\Delta$  are critical for safety. Replace only with part number specified.

Les composants identifiés par une marque  $\Delta$  sont critiques pour la sécurité. Ne les remplacer que par une pièce portant le numéro spécifié.

- CND : Canadian
- WG : West Germany

Ref.No	Part No.	Description	Remark	Ref.No	Part No.	Description	Remark
901	*A-4333-832-A	(US, CND, E, UK, AEP)....MOUNTED PCB, VIDEO		C214	1-130-469-00	MYLAR	680PF 5% 50V
	*A-4334-039-A	(WG)....MOUNTED PCB, VIDEO		C215	1-136-171-00	FILM	0.33MF 5% 50V
902	*A-4333-833-A	MOUNTED PCB, ANALOG		C216	1-136-171-00	FILM	0.33MF 5% 50V
	*A-4334-037-A	(E, UK, AEP, WG)....MOUNTED PCB, ANALOG		C217	1-123-369-00	ELECT	4.7MF 20% 50V
903	*A-4333-834-A	MOUNTED PCB, DIGITAL		C218	1-123-369-00	ELECT	4.7MF 20% 50V
903	*A-4334-038-A	(WG)....MOUNTED PCB, DIGITAL		C219	1-130-481-00	MYLAR	0.0068MF 5% 50V
904	*1-632-454-11	PC BOARD, RY		C220	1-126-023-11	ELECT	100MF 20% 25V
905	$\Delta$ .1-551-238-00	(AEP, WG)....CORD, POWER		C221	1-136-169-00	FILM	0.22MF 5% 50V
	$\Delta$ .1-555-386-00	(E)....CORD, POWER		C222	1-123-369-00	ELECT	4.7MF 20% 50V
	$\Delta$ .1-559-272-11	(UK)....CORD, POWER		C223	1-136-169-00	FILM	0.22MF 5% 50V
905	$\Delta$ .1-559-479-11	(US, CND)....CORD, POWER		C224	1-126-022-11	ELECT	47MF 20% 25V
906	*1-632-446-11	PC BOARD, HP		C225	1-126-059-11	ELECT	10MF 20% 25V
907	*1-632-447-11	PC BOARD, SW		C226	1-136-173-91	FILM	0.47MF 5% 50V
908	*1-632-448-11	PC BOARD, YC		C227	1-126-059-11	ELECT	10MF 20% 25V
909	*1-632-449-11	PC BOARD, VOL LED		C228	1-126-059-11	ELECT	10MF 20% 25V
910	*1-632-450-11	PC BOARD, I VOL		C229	1-126-059-11	ELECT	10MF 20% 25V
911	*1-632-451-11	PC BOARD, B VOL		C232	1-136-165-00	FILM	0.1MF 5% 50V
912	*1-632-452-11	PC BOARD, PIN		C233	1-136-167-00	FILM	0.15MF 5% 50V
913	*1-632-455-11	PC BOARD, M VOL		C234	1-130-469-00	MYLAR	680PF 5% 50V
914	*1-632-453-11	PC BOARD, DISPLAY		C235	1-136-167-00	FILM	0.15MF 5% 50V
915	*1-533-189-11	HOLDER, FUSE		C236	1-123-369-00	ELECT	4.7MF 20% 50V
916	*1-632-445-11	(E)....PC BOARD, VS		C237	1-123-369-00	ELECT	4.7MF 20% 50V
		<b>CAPACITOR</b>		C238	1-130-481-00	MYLAR	0.0068MF 5% 50V
C101	1-110-335-11	MYLAR	100PF 5% 50V	C240	1-136-169-00	FILM	0.22MF 5% 50V
C102	1-123-381-00	ELECT	2.2MF 20% 50V	C241	1-123-369-00	ELECT	4.7MF 20% 50V
C103	1-126-022-11	ELECT	47MF 20% 10V	C242	1-136-169-00	FILM	0.22MF 5% 50V
C104	1-130-480-00	MYLAR	0.0056MF 5% 50V	C243	1-126-059-11	ELECT	10MF 20% 25V
C105	1-130-473-00	MYLAR	0.0015MF 5% 50V	C244	1-126-059-11	ELECT	10MF 20% 25V
C106	1-124-252-00	ELECT	0.33MF 20% 50V	C245	1-126-059-11	ELECT	10MF 20% 25V
C107	1-126-022-11	ELECT	47MF 20% 16V	C246	1-126-022-11	ELECT	47MF 20% 16V
C110	1-136-153-00	FILM	0.01MF 5% 50V	C302	1-164-159-11	CERAMIC	0.1MF 50V
C111	1-126-059-11	ELECT	10MF 20% 25V	C303	1-164-159-11	CERAMIC	0.1MF 50V
C112	1-126-059-11	ELECT	10MF 20% 25V	C305	1-126-022-11	ELECT	47MF 20% 10V
C113	1-126-059-11	ELECT	10MF 20% 25V	C306	1-161-379-00	CERAMIC	0.01MF 30% 16V
C115	1-126-059-11	ELECT	10MF 20% 25V	C307	1-126-059-11	ELECT	10MF 20% 50V
C121	1-110-335-11	MYLAR	100PF 5% 50V	C309	1-164-159-11	CERAMIC	0.1MF 50V
C151	1-110-335-11	MYLAR	100PF 5% 50V	C310	1-126-022-11	ELECT	47MF 20% 10V
C152	1-123-381-00	ELECT	2.2MF 20% 50V	C311	1-161-379-00	CERAMIC	0.01MF 30% 16V
C153	1-126-022-11	ELECT	47MF 20% 10V	C312	1-130-481-00	MYLAR	0.0068MF 5% 50V
C154	1-130-480-00	MYLAR	0.0056MF 5% 50V	C313	1-162-207-31	CERAMIC	22PF 5% 50V
C155	1-130-473-00	MYLAR	0.0015MF 5% 50V	C314	1-162-207-31	CERAMIC	22PF 5% 50V
C156	1-124-252-00	ELECT	0.33MF 20% 50V	C315	1-164-159-11	CERAMIC	0.1MF 50V
C157	1-126-022-11	ELECT	47MF 20% 16V	C316	1-126-022-11	ELECT	47MF 20% 10V
C171	1-110-335-11	MYLAR	100PF 5% 50V	C318	1-164-159-11	CERAMIC	0.1MF 50V
C172	1-161-379-00	CERAMIC	0.01MF 30% 16V	C319	1-126-059-11	ELECT	10MF 20% 50V
C200	1-126-044-11	ELECT	1MF 20% 50V	C320	1-136-165-00	FILM	0.1MF 5% 50V
C204	1-136-153-00	FILM	0.01MF 5% 50V	C410	1-136-233-11	FILM	0.0047MF 5% 100V
C205	1-136-153-00	FILM	0.01MF 5% 50V	C411	1-164-159-11	CERAMIC	0.1MF 50V
C206	1-136-153-00	FILM	0.01MF 5% 50V	C412	1-126-023-11	ELECT	100MF 20% 25V
C207	1-162-215-31	CERAMIC	47PF 5% 50V	C413	1-164-159-11	CERAMIC	0.1MF 50V
C211	1-136-165-00	FILM	0.1MF 5% 50V	C414	1-126-023-11	ELECT	100MF 20% 25V
C212	1-136-165-00	FILM	0.1MF 5% 50V	C415	1-136-233-11	FILM	0.0047MF 5% 100V
C213	1-136-165-00	FILM	0.1MF 5% 50V	C416	1-164-159-11	CERAMIC	0.1MF 50V
				C417	1-164-159-11	CERAMIC	0.1MF 50V
				C418	1-126-022-11	ELECT	47MF 20% 10V



Ref.No	Part No.	Description				Ref.No	Part No.	Description			
C419	1-126-059-11	ELECT	10MF	20%	50V	C669	1-126-059-11	ELECT	10MF	20%	50V
C420	1-136-159-11	CERAMIC	0.1MF		50V	C670	1-136-153-00	FILM	0.01MF	5%	50V
C421	1-164-159-11	CERAMIC	0.1MF		50V	C671	1-130-473-00	MYLAR	0.0015MF	5%	50V
C422	1-162-215-31	CERAMIC	47PF	5%	50V	C672	1-130-478-00	MYLAR	0.0039MF	5%	50V
C519	1-161-379-00	CERAMIC	0.01MF	30%	16V	C673	1-110-339-11	MYLAR	220PF	5%	50V
C520	1-162-211-31	CERAMIC	33PF	5%	50V	C678	1-130-473-00	MYLAR	0.0015MF	5%	50V
C521	1-162-211-31	CERAMIC	33PF	5%	50V	C679	1-110-339-11	MYLAR	220PF	5%	50V
C522	1-126-049-11	ELECT	22MF	20%	25V	C680	1-130-478-00	MYLAR	0.0039MF	5%	50V
C523	1-161-379-00	CERAMIC	0.01MF	30%	16V	C681	1-126-049-11	ELECT	22MF	20%	25V
C525	1-126-049-11	ELECT	22MF	20%	25V	C682	1-136-153-00	FILM	0.01MF	5%	50V
C526	1-161-379-00	CERAMIC	0.01MF	30%	16V	C685	1-126-059-11	ELECT	10MF	20%	50V
C530	1-124-994-11	ELECT	100MF	20%	10V	C686	1-130-468-00	MYLAR	560PF	5%	50V
C531	1-161-379-00	CERAMIC	0.01MF	30%	16V	C690	1-126-059-11	ELECT	10MF	20%	50V
C532	1-124-994-11	ELECT	100MF	20%	10V	C697	1-126-059-11	ELECT	10MF	20%	50V
C535	1-161-379-00	CERAMIC	0.01MF	30%	16V	C698	1-126-023-11	ELECT	100MF	20%	25V
C536	1-124-994-11	ELECT	100MF	20%	10V	C699	1-126-023-11	ELECT	100MF	20%	25V
C537	1-164-159-11	CERAMIC	0.1MF		50V	C701	1-124-471-00	ELECT	1000MF	20%	6.3V
C538	1-126-022-11	ELECT	47MF	20%	10V	C702	1-124-471-00	ELECT	1000MF	20%	6.3V
C601	1-126-059-11	ELECT	10MF	20%	50V	C703	1-124-471-00	ELECT	1000MF	20%	6.3V
C602	1-126-059-11	ELECT	10MF	20%	50V	C704	1-124-471-00	ELECT	1000MF	20%	6.3V
C603	1-126-059-11	ELECT	10MF	20%	50V	C705	1-124-471-00	ELECT	1000MF	20%	6.3V
C604	1-126-059-11	ELECT	10MF	20%	50V	C709	1-123-875-11	ELECT	10MF	20%	50V
C605	1-126-023-11	ELECT	100MF	20%	25V	C710	1-123-875-11	ELECT	10MF	20%	50V
C606	1-126-059-11	ELECT	10MF	20%	50V	C711	1-161-379-00	CERAMIC	0.01MF	30%	16V
C607	1-126-023-11	ELECT	100MF	20%	25V	C712	1-161-379-00	CERAMIC	0.01MF	30%	16V
C608	1-136-257-00	FILM	0.0039MF	5%	100V	C713	1-161-379-00	CERAMIC	0.01MF	30%	16V
C609	1-136-228-11	FILM	0.0012MF	5%	100V	C714	1-136-165-00	FILM	0.1MF	5%	50V
C610	1-126-059-11	ELECT	10MF	20%	50V	C715	1-136-165-00	FILM	0.1MF	5%	50V
C611	1-130-955-00	FILM	0.01MF	5%	100V	C716	1-136-165-00	FILM	0.1MF	5%	50V
C612	1-136-250-11	FILM	0.001MF	5%	100V	C717	1-124-471-00	ELECT	1000MF	20%	6.3V
C613	1-126-022-11	ELECT	47MF	20%	10V	C718	1-124-471-00	ELECT	1000MF	20%	6.3V
C614	1-126-059-11	ELECT	10MF	20%	50V	C719	1-124-471-00	ELECT	1000MF	20%	6.3V
C615	1-164-159-11	CERAMIC	0.1MF		50V	C720	1-123-875-11	ELECT	10MF	20%	50V
C616	1-126-022-11	ELECT	47MF	20%	10V	C721	1-123-875-11	ELECT	10MF	20%	50V
C617	1-126-044-11	ELECT	1MF	20%	50V	C724	1-136-165-00	FILM	0.1MF	5%	50V
C619	1-126-059-11	ELECT	10MF	20%	50V	C725	1-123-875-11	ELECT	10MF	20%	50V
C620	1-136-153-00	FILM	0.01MF	5%	50V	C726	1-123-875-11	ELECT	10MF	20%	50V
C621	1-130-473-00	MYLAR	0.0015MF	5%	50V	C727	1-161-379-00	CERAMIC	0.01MF	30%	16V
C622	1-130-478-00	MYLAR	0.0039MF	5%	50V	C728	1-161-379-00	CERAMIC	0.01MF	30%	16V
C623	1-110-339-11	MYLAR	220PF	5%	50V	C729	1-126-101-11	ELECT	100MF	20%	16V
C624	1-126-059-11	ELECT	10MF	20%	50V	C730	1-126-101-11	ELECT	100MF	20%	16V
C625	1-164-159-11	CERAMIC	0.1MF		50V	C731	1-126-101-11	ELECT	100MF	20%	16V
C626	1-126-022-11	ELECT	47MF	20%	10V	C732	1-126-101-11	ELECT	100MF	20%	16V
C627	1-126-022-11	ELECT	47MF	20%	10V	C733	1-126-101-11	ELECT	100MF	20%	16V
C628	1-130-473-00	MYLAR	0.0015MF	5%	50V	C734	1-123-875-11	ELECT	10MF	20%	50V
C629	1-110-339-11	MYLAR	220PF	5%	50V	C735	1-161-379-00	CERAMIC	0.01MF	30%	16V
C630	1-130-478-00	MYLAR	0.0039MF	5%	50V	C736	1-126-101-11	ELECT	100MF	20%	16V
C631	1-126-049-11	ELECT	22MF	20%	25V	C737	1-161-379-00	CERAMIC	0.01MF	30%	16V
C632	1-136-153-00	FILM	0.01MF	5%	50V	C738	1-161-379-00	CERAMIC	0.01MF	30%	16V
C635	1-126-059-11	ELECT	10MF	20%	50V	C739	1-161-379-00	CERAMIC	0.01MF	30%	16V
C636	1-130-468-00	MYLAR	560PF	5%	50V	C740	1-161-379-00	CERAMIC	0.01MF	30%	16V
C640	1-126-059-11	ELECT	10MF	20%	50V	C741	1-161-379-00	CERAMIC	0.01MF	30%	16V
C650	1-123-607-91	ELECT	0.1MF	20%	50V	C801	1-136-165-00	FILM	0.1MF	5%	50V
C651	1-126-059-11	ELECT	10MF	20%	50V	C802	1-126-059-11	ELECT	10MF	20%	25V
C652	1-126-059-11	ELECT	10MF	20%	50V	C803	1-126-059-11	ELECT	10MF	20%	25V
C653	1-126-059-11	ELECT	10MF	20%	50V	C804	1-126-059-11	ELECT	10MF	20%	25V
C654	1-126-059-11	ELECT	10MF	20%	50V	C805	1-136-171-00	FILM	0.33MF	5%	50V
C655	1-126-023-11	ELECT	100MF	20%	25V	C806	1-136-163-00	FILM	0.068MF	5%	50V
C656	1-126-059-11	ELECT	10MF	20%	50V	C807	1-130-476-00	MYLAR	0.0027MF	5%	50V
C657	1-126-023-11	ELECT	100MF	20%	25V	C808	1-126-059-11	ELECT	10MF	20%	25V
C658	1-136-257-00	FILM	0.0039MF	5%	100V	C809	1-126-059-11	ELECT	10MF	20%	25V
C659	1-136-228-11	FILM	0.0012MF	5%	100V	C810	1-126-059-11	ELECT	10MF	20%	25V
C661	1-130-955-00	FILM	0.01MF	5%	100V	C811	1-161-379-00	CERAMIC	0.01MF	30%	16V
C662	1-136-250-11	FILM	0.001MF	5%	100V	C901	1-126-023-11	ELECT	100MF	20%	16V
C667	1-126-044-11	ELECT	1MF	20%	50V	C902	1-126-023-11	ELECT	100MF	20%	16V

REVISED

CP1001 1-232-701-11 RESISTOR BLOCK  
 CP1002 1-232-701-11 RESISTOR BLOCK

Ref.No	Part No.	Description	Remark
C903	1-126-023-11	ELECT	100MF 20% 16V
C904	1-126-044-11	ELECT	1MF 20% 50V
C905	1-126-023-11	ELECT	100MF 20% 16V
C906	1-126-023-11	ELECT	100MF 20% 16V
C907	1-126-023-11	ELECT	100MF 20% 25V
C909	1-126-024-11	ELECT	220MF 20% 25V
C910	1-126-024-11	ELECT	220MF 20% 25V
C911	1-126-059-11	ELECT	10MF 20% 25V
C912	1-124-918-11	ELECT	47MF 20% 63V
C913	1-126-023-11	ELECT	100MF 20% 16V
C914	1-124-918-11	ELECT	47MF 20% 63V
C915	1-124-628-11	ELECT	220MF 20% 100V
C916	1-126-016-11	ELECT	4700MF 20% 16V
C918	1-124-563-11	ELECT	2200MF 20% 25V
C919	1-124-563-11	ELECT	2200MF 20% 25V
C920	1-130-789-00	FILM	1MF 5% 100V
C921	▲ 1-161-744-00	(US, CND).... CERAMIC	0.01MF 400V
C921	▲ 1-161-741-00	(E, UK, AEP, WG).... CERAMIC	0.001MF 10% 400V
C922	▲ 1-136-279-11	FILM	0.047MF 20% 250V
C924	1-124-563-11	ELECT	2200MF 20% 25V
C925	1-124-563-11	ELECT	2200MF 20% 25V
C930	1-126-044-11	ELECT	1MF 20% 50V
C931	1-124-994-11	ELECT	100MF 20% 6.3V
C932	1-136-177-00	FILM	1MF 5% 50V
C1001	1-124-918-11	ELECT	47MF 20% 63V
C1002	1-161-379-00	CERAMIC	0.01MF 30% 16V
C1003	1-124-446-11	ELECT	47MF 20% 10V
C1004	1-161-379-00	CERAMIC	0.01MF 30% 16V
C1005	1-162-210-31	CERAMIC	30PF 5% 50V
C1006	1-162-210-31	CERAMIC	30PF 5% 50V
C1009	1-161-379-00	CERAMIC	0.01MF 30% 16V
C1010	1-126-059-11	ELECT	10MF 20% 50V
C1011	1-125-548-11	DOUBLE LAYER	0.1F 5.5V
C1012	1-161-379-00	CERAMIC	0.01MF 30% 16V
C1013	1-124-994-11	ELECT	100MF 20% 10V
C1014	1-161-379-00	CERAMIC	0.01MF 30% 16V
C1016	1-162-290-31	CERAMIC	470PF 10% 50V
C1017	1-161-379-00	CERAMIC	0.01MF 30% 16V
CNJ1	*1-564-511-11	PLUG, CONNECTOR 8P	
CNJ3	*1-564-506-11	PLUG, CONNECTOR 3P	
CNJ901	▲ 1-540-059-21	(US, CND, E).....OUTLET, AC	
	▲ 1-526-751-00	(UK).....OUTLET, AC	
	▲ 1-526-988-11	(AEP)..... OUTLET, AC	
CNJ902	▲ 1-540-059-21	(US, CND, E).....OUTLET, AC	
	▲ 1-526-751-00	(UK).....OUTLET, AC	
	▲ 1-526-988-11	(AEP)..... OUTLET, AC	
CNJ903	*1-506-599-11	PIN, CONNECTOR 10P	
CN102	*1-564-505-11	PLUG, CONNECTOR 2P	
CN201	*1-564-506-11	PLUG, CONNECTOR 3P	
CN202	*1-564-506-11	PLUG, CONNECTOR 3P	
CN203	*1-564-506-11	PLUG, CONNECTOR 3P	
CN206	*1-564-506-11	PLUG, CONNECTOR 3P	
CN207	*1-564-506-11	PLUG, CONNECTOR 3P	
CN702	*1-564-704-11	PIN, CONNECTOR 2P	
CN703	*1-564-506-11	PLUG, CONNECTOR 3P	
CN704	*1-564-506-11	PLUG, CONNECTOR 3P	
CN705	*1-564-508-11	PLUG, CONNECTOR 5P	
CN801	*1-564-337-71	PIN, CONNECTOR 3P	
CN802	*1-564-337-81	PIN, CONNECTOR 3P	
CN803	*1-564-337-00	PIN, CONNECTOR 3P	
CN804	*1-564-338-71	PIN, CONNECTOR 4P	
CN805	*1-564-337-71	PIN, CONNECTOR 3P	
CN806	*1-564-338-00	PIN, CONNECTOR 4P	
CN807	*1-564-337-61	PIN, CONNECTOR 3P	
CN808	*1-564-339-00	PIN, CONNECTOR 5P	
CN809	*1-564-336-81	PIN, CONNECTOR 2P	
CN810	*1-564-336-00	PIN, CONNECTOR 2P	

Ref.No	Part No.	Description	Remark
CN811	*1-564-508-21	PIN, CONNECTOR 5P	
CN812	*1-564-337-00	PIN, CONNECTOR 3P	
CN813	*1-564-338-61	PIN, CONNECTOR 4P	
CN814	*1-564-336-61	PIN, CONNECTOR 2P	
CN815	*1-564-341-51	PIN, CONNECTOR 7P	
CN816	*1-564-338-81	PIN, CONNECTOR 4P	
CN817	*1-564-336-71	PIN, CONNECTOR 2P	
CN818	*1-564-340-00	PIN, CONNECTOR 6P	
CN818	*1-564-340-00	PIN, CONNECTOR 6P	
CN819	*1-564-339-61	PIN, CONNECTOR 5P	
CN820	*1-564-341-71	PIN, CONNECTOR 7P	
CN820	*1-564-341-71	PIN, CONNECTOR 7P	
CN821	*1-564-340-71	PIN, CONNECTOR 6P	
CN822	*1-564-342-11	PIN, CONNECTOR 8P	
CN823	*1-564-340-81	PIN, CONNECTOR 6P	
CN824	*1-564-336-61	PIN, CONNECTOR 2P	
CN825	*1-564-340-00	PIN, CONNECTOR 6P	
CN827	*1-564-336-00	PIN, CONNECTOR 2P	
CN828	*1-564-336-71	PIN, CONNECTOR 2P	
D301	8-719-912-20	DIODE 1SS120	
D303	8-719-903-27	DIODE 1SS168	
D304	8-719-912-20	DIODE 1SS120	
D305	8-719-912-20	DIODE 1SS120	
D401	8-719-912-20	DIODE 1SS120	
D402	8-719-912-20	DIODE 1SS120	
D403	8-719-912-20	DIODE 1SS120	
D404	8-719-912-20	DIODE 1SS120	
D901	▲ 8-719-200-02	DIODE 10E2	
D902	8-719-200-02	DIODE 10E2	
D904	8-719-200-02	DIODE 10E2	
D905	8-719-014-98	DIODE UZP-8.2B	
D906	8-719-002-36	DIODE UZL-24M	
D907	8-719-911-55	DIODE U05G	
D908	8-719-911-55	DIODE U05G	
D909	8-719-200-02	DIODE 10E2	
D910	8-719-200-02	DIODE 10E2	
D911	8-719-200-02	DIODE 10E2	
D912	8-719-200-02	DIODE 10E2	
D913	8-719-200-02	DIODE 10E2	
D914	8-719-911-55	DIODE U05G	
D915	8-719-911-55	DIODE U05G	
D916	8-719-002-36	DIODE UZL-24M	
D917	8-719-200-02	DIODE 10E2	
D1001	8-719-301-52	LED SEL2810A-C (SURROUND)	
D1002	8-719-301-52	LED SEL2810A-C (DYNAMICS)	
D1004	8-719-301-43	LED SEL2410E-C (48KHz)	
D1005	8-719-301-43	LED SEL2410E-C (44KHz)	
D1006	8-719-301-43	LED SEL2410E-C (32KHz)	
D1007	8-719-301-52	LED SEL2810A-C (ROOM SIZE, WALL)	
D1008	8-719-301-52	LED SEL2810A-C (SEAT POSITION REAR-FRPM/LEFT-RIGHT)	
D1009	8-719-301-52	LED SEL2810A-C (CENTER LEVEL, REAR LEVEL)	
D1010	8-719-301-52	LED SEL2810A-C (EQ LEVEL, EQ FREQUENCY)	
D1011	8-719-301-52	LED SEL2810A-C (MAIN PARAMETER)	
D1012	8-719-301-52	LED SEL2810A-C (SUB PARAMETER)	
D1013	8-719-301-52	LED SEL2810A-C (MUTING)	
D1014	8-719-912-20	DIODE 1SS120	
D1015	8-719-912-20	DIODE 1SS120	
D1016	8-719-912-20	DIODE 1SS120	
D1017	8-719-912-20	DIODE 1SS120	
D1018	8-719-200-02	DIODE 10E2	
D1019	8-719-912-20	DIODE 1SS120	
D1020	8-719-912-20	DIODE 1SS120	
D1050A	8-719-301-43	LED SEL2410E-C (VOLUME)	
D1050B	8-719-300-71	(UK, AEP, WG)....LED SEL2110R (POWER)	

**Note:**  
 The components identified by mark ▲ or dotted line with mark ▲ are critical for safety. Replace only with part number specified.

**Note:**  
 Les composants identifiés par une marque ▲ sont critiques pour la sécurité. Ne les remplacer que par une pièce portant le numéro spécifié.

Ref.No	Part No.	Description	Remark	Ref.No	Part No.	Description	Remark
F901	△ 1-532-284-00	(UK, AEP, WG)....FUSE, TIME LAG 0.63A		IC901	8-759-604-33	IC M5F7812	
F901	△ 1-532-740-11	(US, CND)....FUSE, GLASS TUBE (125V 1A)		IC902	8-759-604-51	IC M5F7912	
F902	△ 1-532-299-00	(AEP, WG)....FUSE, TIME LAG 5,0A		IC903	8-759-604-35	IC M5F78M05	
F903	△ 1-532-284-00	(E)....FUSE, TIME-LAG 0.63A		IC904	8-759-982-52	IC RC79M05FA	
F904	△ 1-532-284-00	(E)....FUSE, TIME-LAG 0.63A		IC905	8-759-820-84	IC L78MR05	
FL1001	1-519-553-11	INDICATOR TUBE, FLUORESCENT		IC906	8-759-604-29	IC M5F7805	
IC101	8-759-106-41	IC UPC4570C		IC1001	8-759-146-52	IC UPD78224	
IC102	8-759-805-13	IC LC7821		IC1002	8-759-148-04	IC UPD75004CU	
IC103	8-759-805-13	IC LC7821		IC1003	8-759-990-38	IC MSC1162GS	
IC104	8-759-805-14	IC LC7822		IC1004	8-759-990-38	IC MSC1162GS	
IC105	8-759-805-14	IC LC7822		IC1005	8-759-990-38	IC MSC1162GS	
IC106	8-759-995-08	IC RC4558P		IC1006	8-759-202-97	IC TC74HC165P	
IC107	8-759-710-59	IC NJM4580D-D		IC1050	8-749-920-59	IC A1QH3020S	
IC201	8-759-200-11	IC TC4011UBP		J101	1-565-320-11	(US, CND, E, UK, AE)....JACK, PIN 6P	
IC202	8-759-945-58	IC RC4558P		J101	1-565-320-11	(WG)....JACK, PIN 6P	
IC203	8-759-208-08	IC TC4052BPHB		J102	1-565-320-11	JACK, PIN 6P	
IC204	8-759-208-08	IC TC4052BPHB		J103	1-565-258-11	JACK, PIN 4P	
IC205	8-759-821-99	IC LA2770		J104	1-565-258-11	JACK, PIN 4P	
IC206	8-759-820-11	IC LC7535		J105	1-565-258-11	JACK, PIN 4P	
IC207	8-759-945-58	IC RC4558P		J106	1-565-258-11	JACK, PIN 4P	
IC208	8-759-945-58	IC RC4558P		J107	1-565-258-11	JACK, PIN 4P	
IC209	8-759-113-18	IC UPC4574C		J301	1-565-750-11	JACK, PIN (1P SHIELD TYPE) (COAXIAL IN)	
IC301	8-759-977-72	IC GP1F31R (OPTICAL 2 IN)		J701	1-565-351-11	JACK, PIN 3P (TV/VDP/VIDEO 4 VIDEO IN)	
IC302	8-759-977-72	IC GP1F31R (OPTICAL 1 IN)		J702	1-565-351-11	JACK, PIN 3P (VIDEO 2/3 VIDEO OUT, VIDEO 3 VIDEO IN)	
IC304	8-759-977-71	IC GP1F31T (OPTICAL 2 REC OUT)		J703	1-565-351-11	JACK, PIN 3P (VIDEO 1/2 VIDEO IN, VIDEO 1 VIDEO OUT)	
IC305	8-759-804-69	IC LC74HC04M		J704	1-565-319-11	JACK, PIN 2P (MONITOR VIDEO OUT 1/2)	
IC306	8-759-202-93	IC TC74HC153P		J705	1-566-846-11	CONNECTOR, (S) TERMINAL 4P (VIDEO 2 S VIDEO OUT)	
IC307	8-759-973-98	IC YM3623B		J706	1-566-846-11	CONNECTOR, (S) TERMINAL 4P (VIDEO 2 S VIDEO IN)	
IC308	8-759-202-11	IC TC74HCOOP		J707	1-566-846-11	CONNECTOR, (S) TERMINAL 4P (VIDEO 1 S VIDEO OUT)	
IC309	8-759-202-11	IC TC74HCOOP		J708	1-566-846-11	CONNECTOR, (S) TERMINAL 4P (VIDEO 1 S VIDEO IN)	
IC311	8-759-202-93	IC TC74HC153P		J711	1-566-846-11	CONNECTOR, (S) TERMINAL 4P (MONITOR S VIDEO OUT)	
IC379	8-759-990-82	IC TL082CP		J801A	1-565-320-11	(US, CND, E, UK, AEP)....JACK, PIN 6P (LINE OUT FRONT/REAR)	
IC401	8-759-801-01	IC LC4966		J801A	1-565-320-11	(WG)....JACK PIN 6P	
IC402	8-759-989-42	IC AK5326-VP		J801B	1-566-847-21	CONNECTOR, (S) TERMINAL 4P (VIDEO 5 S VIDEO INPUT)	
IC501	8-759-987-63	IC MSM514256-10RS		J802	1-565-352-31	JACK, PIN 2P (LINE OUT SUBWOOFER/CENTER)	
IC505	8-759-804-69	IC LC74HC04M		J810	1-563-136-61	JACK, PIN (VIDEO 5 INPUT AUDIO/VIDEO)	
IC506	8-752-331-87	IC CXD1160AP		J850	1-507-982-31	JACK (LARGE TYPE) (HEADPHONES)	
IC507	8-752-331-87	IC CXD1160AP		J901	1-535-476-11	TERMINAL	
IC508	8-752-334-06	IC CXD2551P		J902	1-535-476-11	TERMINAL	
IC509	8-759-979-94	IC CXD1355Q		J1001	1-566-213-11	PIN, CONNECTOR 4P (CONTROL S IN)	
IC512	8-759-979-94	IC CXD1355Q		J1002	1-566-213-11	PIN, CONNECTOR 4P (CONTROL S OUT)	
IC513	8-759-987-63	IC MSM514256-10RS		L301	1-410-324-11	INDUCTOR 4.7UH	
IC601	8-759-987-07	IC PCM1701P		L302	1-410-324-11	INDUCTOR 4.7UH	
IC602	8-759-710-59	IC NJM4580D-D		L303	1-410-324-11	INDUCTOR 4.7UH	
IC605	8-759-145-79	IC UPD6372CX		L304	1-410-324-11	INDUCTOR 4.7UH	
IC606	8-759-145-79	IC UPD6372CX		L305	1-410-324-11	INDUCTOR 4.7UH	
IC607	8-759-945-58	IC RC4558P		L307	*1-410-858-11	INDUCTOR 0UH	
IC608	8-759-945-58	IC RC4558P		L308	*1-410-858-11	INDUCTOR 0UH	
IC651	8-759-987-07	IC PCM1701P		L401	1-410-324-11	INDUCTOR 4.7UH	
IC652	8-759-710-59	IC NJM4580D-D		L402	1-410-324-21	INDUCTOR 4.7UH	
IC670	8-759-801-01	IC LC4966		L501	1-410-324-11	INDUCTOR 4.7UH	
IC671	8-759-820-11	IC LC7535		L502	1-410-324-11	INDUCTOR 4.7UH	
IC672	8-759-113-18	IC UPC4574C		L503	1-410-324-11	INDUCTOR 4.7UH	
IC673	8-759-945-58	IC RC4558P		L701	1-410-858-11	INDUCTOR 100UH	
IC701	8-759-805-14	IC LC7822		L702	1-410-858-11	INDUCTOR 100UH	
IC702	8-759-805-14	IC LC7822		L703	1-410-858-11	INDUCTOR 100UH	
IC703	8-759-030-67	IC MC14576AP		L704	1-410-858-11	INDUCTOR 100UH	
IC704	8-759-805-15	IC LC7823					
IC705	8-759-805-15	IC LC7823					
IC706	8-759-030-67	IC MC14576AP					
IC707	8-759-030-67	IC MC14576AP					
IC801	8-759-820-62	IC LB1639					
IC802	8-759-945-58	IC RC4558P					
IC803	8-759-945-58	IC RC4558P					
IC804	8-759-710-59	IC NJM4580D-D					

**Note:**

The components identified by mark △ or dotted line with mark △ are critical for safety. Replace only with part number specified.

**Note:**

Les composants identifiés par une marque △ sont critiques pour la sécurité. Ne les remplacer que par une pièce portant le numéro spécifié.



Ref.No	Part No.	Description
NO.701	*1-564-518-11	PLUG, CONNECTOR 3P
Q211	8-729-900-80	TRANSISTOR DTC114ES
Q212	8-729-900-80	TRANSISTOR DTC114ES
Q213	8-729-900-80	TRANSISTOR DTC114ES
Q214	8-729-900-80	TRANSISTOR DTC114ES
Q301	8-729-119-78	TRANSISTOR 2SC2785-HFE
Q302	8-729-900-61	TRANSISTOR DTA114ES
Q303	8-729-900-61	TRANSISTOR DTA114ES
Q401	8-729-115-77	TRANSISTOR BA1L4M
Q402	8-729-900-65	TRANSISTOR DTA144ES
Q403	8-729-115-77	TRANSISTOR BA1L4M
Q601	8-729-224-62	TRANSISTOR 2SK246GR
Q608	8-729-107-84	TRANSISTOR 2SC3623A-L
Q621	8-729-107-84	TRANSISTOR 2SC3623A-L
Q651	8-729-224-62	TRANSISTOR 2SK246GR
Q658	8-729-107-84	TRANSISTOR 2SC3623A-L
Q671	8-729-107-84	TRANSISTOR 2SC3623A-L
Q672	8-729-900-65	TRANSISTOR DTA144ES
Q673	8-729-115-77	TRANSISTOR BA1L4M
Q674	8-729-900-65	TRANSISTOR DTA144ES
Q675	8-729-224-62	TRANSISTOR 2SK246GR
Q676	8-729-108-14	TRANSISTOR 2SA988-F
Q677	8-729-900-61	TRANSISTOR DTA114ES
Q678	8-729-115-77	TRANSISTOR BA1L4M
Q679	8-729-108-05	TRANSISTOR 2SK1841-PA
Q701	8-729-119-76	TRANSISTOR 2SA1175-HFE
Q702	8-729-119-76	TRANSISTOR 2SA1175-HFE
Q703	8-729-119-76	TRANSISTOR 2SA1175-HFE
Q704	8-729-119-76	TRANSISTOR 2SA1175-HFE
Q705	8-729-119-76	TRANSISTOR 2SA1175-HFE
Q706	8-729-900-74	TRANSISTOR DTC143TS
Q707	8-729-900-74	TRANSISTOR DTC143TS
Q708	8-729-900-74	TRANSISTOR DTC143TS
Q709	8-729-119-76	TRANSISTOR 2SA1175-HFE
Q710	8-729-119-76	TRANSISTOR 2SA1175-HFE
Q711	8-729-119-76	TRANSISTOR 2SA1175-HFE
Q712	8-729-119-76	TRANSISTOR 2SA1175-HFE
Q713	8-729-119-78	TRANSISTOR 2SC2785-HFE
Q715	8-729-119-78	TRANSISTOR 2SC2785-HFE
Q801	8-729-107-91	TRANSISTOR 2SC3622-L
Q802	8-729-107-91	TRANSISTOR 2SC3622-L
Q803	8-729-107-91	TRANSISTOR 2SC3622-L
Q804	8-729-107-91	TRANSISTOR 2SC3622-L
Q805	8-729-107-91	TRANSISTOR 2SC3622-L
Q806	8-729-107-91	TRANSISTOR 2SC3622-L
Q807	8-729-107-91	TRANSISTOR 2SC3622-L
Q808	8-729-107-91	TRANSISTOR 2SC3622-L
Q901	8-729-119-78	TRANSISTOR 2SC2785-HFE
Q902	8-729-119-76	TRANSISTOR 2SA1175-HFE
Q903	8-729-119-78	TRANSISTOR 2SC2785-HFE
Q905	8-729-173-13	TRANSISTOR 2SB731
Q906	8-729-119-78	TRANSISTOR 2SC2785-HFE
Q907	8-729-173-13	TRANSISTOR 2SB731
Q908	8-729-180-92	TRANSISTOR 2SD809-K
Q909	8-729-140-96	TRANSISTOR 2SD774-34
Q910	8-729-900-61	TRANSISTOR DTA114ES
Q1001	8-729-900-80	TRANSISTOR DTC114ES
Q1002	8-729-900-80	TRANSISTOR DTC114ES
Q1003	8-729-900-80	TRANSISTOR DTC114ES
Q1004	8-729-900-80	TRANSISTOR DTC114ES
Q1005	8-729-900-80	TRANSISTOR DTC114ES
Q1006	8-729-900-80	TRANSISTOR DTC114ES
Q1007	8-729-900-80	TRANSISTOR DTC114ES
Q1008	8-729-900-80	TRANSISTOR DTC114ES
Q1009	8-729-900-80	TRANSISTOR DTC114ES

Ref.No	Part No.	Description
Q1010	8-729-900-80	TRANSISTOR DTC114ES
Q1011	8-729-900-80	TRANSISTOR DTC114ES
Q1012	8-729-900-80	TRANSISTOR DTC114ES
Q1013	8-729-900-80	TRANSISTOR DTC114ES
Q1021	8-729-119-78	TRANSISTOR 2SC2785-HFE
Q1022	8-729-107-84	TRANSISTOR 2SC3623A-L
Q1023	8-729-900-80	TRANSISTOR DTC114ES
Q1025	8-729-119-78	TRANSISTOR 2SC2785-HFE
Q1029	8-729-900-80	TRANSISTOR DTC114ES
Q1031	8-729-900-80	(UK, AEP, WG)....TRANSISTOR DTC114ES
Q1032	8-729-900-80	(UK, AEP, WG)....TRANSISTOR DTC114ES

RESISTOR

Ref.No	Part No.	Description			
R101	1-259-416-11	CARBON	330	5%	1/6W
R102	1-259-476-11	CARBON	100K	5%	1/6W
R103	1-249-469-11	CARBON	100K	5%	1/4W
R104	1-259-426-11	CARBON	820	5%	1/6W
R105	1-259-494-11	CARBON	560K	5%	1/6W
R106	1-259-468-11	CARBON	47K	5%	1/6W
R107	1-259-476-11	CARBON	100K	5%	1/6W
R108	1-259-412-11	CARBON	220	5%	1/6W
R109	1-249-536-91	CARBON	220	5%	1/4W
R110	1-259-428-11	CARBON	1K	5%	1/6W
R111	1-259-484-11	CARBON	220K	5%	1/6W
R112	1-259-428-11	CARBON	1K	5%	1/6W
R113	1-259-484-11	CARBON	220K	5%	1/6W
R114	1-259-428-11	CARBON	1K	5%	1/6W
R115	1-259-484-11	CARBON	220K	5%	1/6W
R116	1-259-428-11	CARBON	1K	5%	1/6W
R117	1-259-484-11	CARBON	220K	5%	1/6W
R118	1-259-428-11	CARBON	1K	5%	1/6W
R119	1-259-484-11	CARBON	220K	5%	1/6W
R120	1-259-428-11	CARBON	1K	5%	1/6W
R121	1-259-484-11	CARBON	220K	5%	1/6W
R122	1-259-428-11	CARBON	1K	5%	1/6W
R123	1-259-484-11	CARBON	220K	5%	1/6W
R124	1-259-428-11	CARBON	1K	5%	1/6W
R125	1-259-484-11	CARBON	220K	5%	1/6W
R126	1-259-428-11	CARBON	1K	5%	1/6W
R127	1-259-484-11	CARBON	220K	5%	1/6W
R128	1-259-428-11	CARBON	1K	5%	1/6W
R129	1-259-484-11	CARBON	220K	5%	1/6W
R130A	1-249-417-11	CARBON	1K	5%	1/4W
R130B	1-249-417-11	CARBON	1K	5%	1/4W
R131A	1-247-887-00	CARBON	220K	5%	1/4W
R131B	1-247-887-00	CARBON	220K	5%	1/4W
R132	1-259-428-11	CARBON	1K	5%	1/6W
R133	1-259-484-11	CARBON	220K	5%	1/6W
R134	1-259-428-11	CARBON	1K	5%	1/6W
R135	1-259-484-11	CARBON	220K	5%	1/6W
R136	1-259-428-11	CARBON	1K	5%	1/6W
R137	1-259-484-11	CARBON	220K	5%	1/6W
R138	1-259-428-11	CARBON	1K	5%	1/6W
R139	1-259-484-11	CARBON	220K	5%	1/6W
R140	1-259-428-11	CARBON	1K	5%	1/6W
R141	1-259-484-11	CARBON	220K	5%	1/6W
R142	1-259-476-91	CARBON	100K	5%	1/6W
R143	1-259-468-91	CARBON	47K	5%	1/6W
R145	1-259-476-11	CARBON	100K	5%	1/6W
R148	1-259-444-11	CARBON	4.7K	5%	1/6W
R149	1-259-452-11	CARBON	10K	5%	1/6W
R151	1-259-416-11	CARBON	330	5%	1/6W
R152	1-259-476-11	CARBON	100K	5%	1/6W
R153	1-259-476-11	CARBON	100K	5%	1/6W
R154	1-259-426-11	CARBON	820	5%	1/6W

Ref.No	Part No.	Description									
R155	1-259-494-11	CARBON	560K	5%	1/6W	R223	1-259-492-11	CARBON	470K	5%	1/6W
R156	1-259-468-11	CARBON	47K	5%	1/6W	R224	1-259-452-11	CARBON	10K	5%	1/6W
R157	1-259-476-11	CARBON	100K	5%	1/6W	R225	1-259-458-11	CARBON	4.7K	5%	1/6W
R158	1-259-412-11	CARBON	220	5%	1/6W	R227	1-259-458-11	CARBON	4.7K	5%	1/6W
R159	1-249-536-91	CARBON	220	5%	1/4W	R228	1-259-500-11	CARBON	1M	5%	1/6W
R160	1-259-428-11	CARBON	1K	5%	1/6W	R230	1-259-456-11	CARBON	15K	5%	1/6W
R161	1-259-484-11	CARBON	220K	5%	1/6W	R231	1-259-436-11	CARBON	2.2K	5%	1/6W
R162	1-259-428-11	CARBON	1K	5%	1/6W	R240	1-259-466-11	CARBON	39K	5%	1/6W
R163	1-259-484-11	CARBON	220K	5%	1/6W	R241	1-259-444-11	CARBON	4.7K	5%	1/6W
R164	1-259-484-11	CARBON	220K	5%	1/6W	R242	1-259-466-11	CARBON	39K	5%	1/6W
R165	1-259-428-11	CARBON	1K	5%	1/6W	R243	1-259-444-11	CARBON	4.7K	5%	1/6W
R166	1-259-428-11	CARBON	1K	5%	1/6W	R301	1-249-405-11	CARBON	100	5%	1/4W
R167	1-259-484-11	CARBON	220K	5%	1/6W	R302	1-249-405-11	CARBON	100	5%	1/4W
R168	1-259-428-11	CARBON	1K	5%	1/6W	R304	1-249-405-11	CARBON	100	5%	1/4W
R169	1-259-484-11	CARBON	220K	5%	1/6W	R305	1-247-903-00	CARBON	1M	5%	1/4W
R170	1-259-428-11	CARBON	1K	5%	1/6W	R306	1-249-441-11	CARBON	100K	5%	1/4W
R171	1-259-484-11	CARBON	220K	5%	1/6W	R308	1-259-408-11	CARBON	150	5%	1/6W
R172	1-259-428-11	CARBON	1K	5%	1/6W	R309	1-249-405-11	CARBON	100	5%	1/4W
R173	1-259-484-11	CARBON	220K	5%	1/6W	R310	1-247-903-00	CARBON	1M	5%	1/4W
R174	1-259-428-11	CARBON	1K	5%	1/6W	R311	1-249-429-11	CARBON	10K	5%	1/4W
R175	1-259-484-11	CARBON	220K	5%	1/6W	R313	1-249-441-11	CARBON	100K	5%	1/4W
R176	1-259-428-11	CARBON	1K	5%	1/6W	R314	1-249-417-11	CARBON	1K	5%	1/4W
R177	1-259-484-11	CARBON	220K	5%	1/6W	R317	1-247-887-00	CARBON	220K	5%	1/4W
R178	1-259-428-11	CARBON	1K	5%	1/6W	R318	1-249-441-11	CARBON	100K	5%	1/4W
R179	1-259-484-11	CARBON	220K	5%	1/6W	R319	1-249-441-11	CARBON	100K	5%	1/4W
R180A	1-249-417-11	CARBON	1K	5%	1/4W	R320	1-249-417-11	CARBON	1K	5%	1/4W
R180B	1-249-417-11	CARBON	1K	5%	1/4W	R321	1-249-425-11	CARBON	4.7K	5%	1/4W
R181A	1-247-887-00	CARBON	220K	5%	1/4W	R324	1-249-441-11	CARBON	100K	5%	1/4W
R181B	1-247-887-00	CARBON	220K	5%	1/4W	R326	1-249-441-11	CARBON	100K	5%	1/4W
R182	1-259-428-11	CARBON	1K	5%	1/6W	R327	1-249-405-11	CARBON	100	5%	1/4W
R183	1-259-484-11	CARBON	220K	5%	1/6W	R330	1-247-804-11	CARBON	75	5%	1/4W
R184	1-259-428-11	CARBON	1K	5%	1/6W	R401	1-249-441-11	CARBON	100K	5%	1/4W
R185	1-259-484-11	CARBON	220K	5%	1/6W	R403	1-259-408-11	CARBON	150	5%	1/6W
R186	1-259-428-11	CARBON	1K	5%	1/6W	R404	1-259-436-11	CARBON	2.2K	5%	1/6W
R187	1-259-484-11	CARBON	220K	5%	1/6W	R405	1-259-440-11	CARBON	3.3K	5%	1/6W
R188	1-259-428-11	CARBON	1K	5%	1/6W	R411	1-249-421-11	CARBON	2.2K	5%	1/4W
R189	1-259-484-11	CARBON	220K	5%	1/6W	R412	1-247-895-81	CARBON	470K	5%	1/4W
R190	1-259-428-11	CARBON	1K	5%	1/6W	R414	1-247-807-81	CARBON	100	5%	1/4W
R191	1-259-484-11	CARBON	220K	5%	1/6W	R453	1-259-408-11	CARBON	150	5%	1/6W
R192	1-259-476-91	CARBON	100K	5%	1/6W	R454	1-259-436-11	CARBON	2.2K	5%	1/6W
R193	1-259-468-91	CARBON	47K	5%	1/6W	R455	1-259-440-11	CARBON	3.3K	5%	1/6W
R195	1-259-476-11	CARBON	100K	5%	1/6W	R530	1-247-903-00	CARBON	1M	5%	1/4W
R196	1-259-452-11	CARBON	10K	5%	1/6W	R540	1-249-413-11	CARBON	470	5%	1/4W
R198	1-259-444-11	CARBON	4.7K	5%	1/6W	R541	1-249-405-11	CARBON	100	5%	1/4W
R199	1-259-452-11	CARBON	10K	5%	1/6W	R543	1-249-405-11	CARBON	100	5%	1/4W
R201	1-259-460-11	CARBON	22K	5%	1/6W	R544	1-249-405-11	CARBON	100	5%	1/4W
R202	1-259-430-91	CARBON	1.2K	5%	1/6W	R601	1-247-901-11	CARBON	820K	5%	1/4W
R203	1-259-468-11	CARBON	47K	5%	1/6W	R602	1-247-720-11	CARBON	3.9K	5%	1/4W
R204	1-259-468-11	CARBON	47K	5%	1/6W	R603	1-247-723-11	CARBON	6.8K	5%	1/4W
R205	1-259-476-11	CARBON	100K	5%	1/6W	R604	1-247-717-11	CARBON	2.2K	5%	1/4W
R207	1-259-456-11	CARBON	15K	5%	1/6W	R605	1-247-712-11	CARBON	820	5%	1/4W
R208	1-259-447-11	CARBON	6.2K	5%	1/6W	R606	1-247-717-11	CARBON	2.2K	5%	1/4W
R209	1-259-476-11	CARBON	100K	5%	1/6W	R607	1-247-885-00	CARBON	180K	5%	1/4W
R210	1-259-476-11	CARBON	100K	5%	1/6W	R615	1-249-437-11	CARBON	47K	5%	1/4W
R211	1-259-468-11	CARBON	47K	5%	1/6W	R616	1-249-423-11	CARBON	3.3K	5%	1/4W
R212	1-259-468-11	CARBON	47K	5%	1/6W	R617	1-249-423-11	CARBON	3.3K	5%	1/4W
R213	1-259-456-11	CARBON	15K	5%	1/6W	R618	1-249-423-11	CARBON	3.3K	5%	1/4W
R214	1-259-449-11	CARBON	7.5K	5%	1/6W	R619	1-249-437-11	CARBON	47K	5%	1/4W
R215	1-259-492-11	CARBON	470K	5%	1/6W	R625	1-249-434-11	CARBON	27K	5%	1/4W
R216	1-259-452-11	CARBON	10K	5%	1/6W	R626	1-249-426-11	CARBON	5.6K	5%	1/4W
R217	1-259-444-11	CARBON	4.7K	5%	1/6W	R627	1-249-441-11	CARBON	100K	5%	1/4W
R219	1-259-436-11	CARBON	2.2K	5%	1/6W	R628	1-249-423-11	CARBON	3.3K	5%	1/4W
R220	1-259-436-11	CARBON	2.2K	5%	1/6W	R629	1-249-423-11	CARBON	3.3K	5%	1/4W
R221	1-259-476-11	CARBON	100K	5%	1/6W	R630	1-249-423-11	CARBON	3.3K	5%	1/4W
R222	1-259-449-11	CARBON	7.5K	5%	1/6W	R631	1-249-437-11	CARBON	47K	5%	1/4W

Ref.No	Part No.	Description					Ref.No	Part No.	Description				
R632	1-249-418-11	CARBON	1.2K	5%	1/4W		R718	1-249-413-11	CARBON	470	5%	1/4W	
R633	1-249-426-11	CARBON	5.6K	5%	1/4W		R719	1-249-413-11	CARBON	470	5%	1/4W	
R635	1-249-409-11	CARBON	220	5%	1/4W		R720	1-249-413-11	CARBON	470	5%	1/4W	
R636	1-249-409-11	CARBON	220	5%	1/4W		R721	1-249-413-11	CARBON	470	5%	1/4W	
R638	1-249-409-11	CARBON	220	5%	1/4W		R722	1-249-413-11	CARBON	470	5%	1/4W	
R640	1-259-460-11	CARBON	22K	5%	1/4W		R723	1-249-405-11	CARBON	100	5%	1/4W	
R641	1-247-839-81	CARBON	2.2K	5%	1/4W		R725	1-249-405-11	CARBON	100	5%	1/4W	
R643	1-259-460-11	CARBON	22K	5%	1/4W		R727	1-249-421-11	CARBON	2.2K	5%	1/4W	
R648	1-249-418-11	CARBON	1.2K	5%	1/4W		R729	1-249-421-11	CARBON	2.2K	5%	1/4W	
R649	1-249-422-11	CARBON	2.7K	5%	1/4W		R731	1-249-421-11	CARBON	2.2K	5%	1/4W	
R651	1-247-901-11	CARBON	820K	5%	1/4W		R733	1-249-428-11	CARBON	8.2K	5%	1/4W	
R652	1-247-720-11	CARBON	3.9K	5%	1/4W		R735	1-249-403-11	CARBON	68	5%	1/4W	
R653	1-247-723-11	CARBON	6.8K	5%	1/4W		R736	1-249-403-11	CARBON	68	5%	1/4W	
R654	1-247-717-11	CARBON	2.2K	5%	1/4W		R737	1-249-403-11	CARBON	68	5%	1/4W	
R655	1-247-712-11	CARBON	820	5%	1/4W		R738	1-249-403-11	CARBON	68	5%	1/4W	
R656	1-247-717-11	CARBON	2.2K	5%	1/4W		R739	1-249-403-11	CARBON	68	5%	1/4W	
R657	1-247-885-00	CARBON	180K	5%	1/4W		R740	1-249-403-11	CARBON	68	5%	1/4W	
R665	1-249-437-11	CARBON	47K	5%	1/4W		R741	1-247-804-11	CARBON	75	5%	1/4W	
R666	1-249-423-11	CARBON	3.3K	5%	1/4W		R742	1-247-804-11	CARBON	75	5%	1/4W	
R667	1-249-423-11	CARBON	3.3K	5%	1/6W		R743	1-247-804-11	CARBON	75	5%	1/4W	
R668	1-249-423-11	CARBON	3.3K	5%	1/4W		R744	1-247-804-11	CARBON	75	5%	1/4W	
R669	1-249-437-11	CARBON	47K	5%	1/4W		R749	1-247-804-11	CARBON	75	5%	1/4W	
R671	1-249-441-11	CARBON	100K	5%	1/4W		R750	1-247-804-11	CARBON	75	5%	1/4W	
R672	1-249-437-11	CARBON	47K	5%	1/4W		R751	1-249-429-11	CARBON	10K	5%	1/4W	
R673	1-247-901-11	CARBON	820K	5%	1/4W		R752	1-249-429-11	CARBON	10K	5%	1/4W	
R674	1-249-441-11	CARBON	100K	5%	1/4W		R753	1-249-429-11	CARBON	10K	5%	1/4W	
R675	1-249-434-11	CARBON	27K	5%	1/4W		R754	1-249-429-11	CARBON	10K	5%	1/4W	
R676	1-249-426-11	CARBON	5.6K	5%	1/4W		R755	1-249-429-11	CARBON	10K	5%	1/4W	
R677	1-249-441-11	CARBON	100K	5%	1/4W		R756	1-249-429-11	CARBON	10K	5%	1/4W	
R678	1-249-423-11	CARBON	3.3K	5%	1/4W		R757	1-249-413-11	CARBON	470	5%	1/4W	
R679	1-249-423-11	CARBON	3.3K	5%	1/4W		R758	1-249-413-11	CARBON	470	5%	1/4W	
R680	1-249-423-11	CARBON	3.3K	5%	1/4W		R759	1-249-413-11	CARBON	470	5%	1/4W	
R681	1-249-437-11	CARBON	47K	5%	1/4W		R760	1-249-413-11	CARBON	470	5%	1/4W	
R682	1-249-418-11	CARBON	1.2K	5%	1/4W		R763	1-249-405-11	CARBON	100	5%	1/4W	
R683	1-249-426-11	CARBON	5.6K	5%	1/4W		R765	1-249-405-11	CARBON	100	5%	1/4W	
R684	1-249-430-11	CARBON	12K	5%	1/4W		R767	1-249-405-11	CARBON	100	5%	1/4W	
R685	1-249-429-11	CARBON	10K	5%	1/4W		R769	1-249-405-11	CARBON	100	5%	1/4W	
R686	1-249-441-11	CARBON	100K	5%	1/4W		R772	1-249-422-11	CARBON	2.7K	5%	1/4W	
R687	1-249-429-11	CARBON	10K	5%	1/4W		R773	1-249-441-11	CARBON	100K	5%	1/4W	
R688	1-249-429-11	CARBON	10K	5%	1/4W		R774	1-249-441-11	CARBON	100K	5%	1/4W	
R689	1-249-437-11	CARBON	47K	5%	1/4W		R775	1-249-441-11	CARBON	100K	5%	1/4W	
R690	1-249-417-11	CARBON	1K	5%	1/4W		R776	1-249-428-11	CARBON	8.2K	5%	1/4W	
R691	1-249-839-81	CARBON	2.2K	5%	1/4W		R777	1-249-429-11	CARBON	10K	5%	1/4W	
R692	1-249-430-11	CARBON	12K	5%	1/4W		R778	1-249-422-11	CARBON	2.7K	5%	1/4W	
R693	1-249-429-11	CARBON	10K	5%	1/4W		R780	1-249-441-11	CARBON	100K	5%	1/4W	
R695	1-247-895-00	CARBON	470K	5%	1/4W		R781	1-247-887-00	CARBON	220K	5%	1/4W	
R698	1-249-418-11	CARBON	1.2K	5%	1/4W		R782	1-247-887-00	CARBON	220K	5%	1/4W	
R699	1-249-422-11	CARBON	2.7K	5%	1/4W		R783	1-247-887-00	CARBON	220K	5%	1/4W	
R701	1-249-403-11	CARBON	68	5%	1/4W		R784	1-247-895-81	CARBON	470K	5%	1/4W	
R702	1-247-804-11	CARBON	75	5%	1/4W		R785	1-247-895-81	CARBON	470K	5%	1/4W	
R703	1-247-804-11	CARBON	75	5%	1/4W		R801	1-259-476-11	CARBON	100K	5%	1/6W	
R704	1-247-804-11	CARBON	75	5%	1/4W		R802	1-259-476-11	CARBON	100K	5%	1/6W	
R705	1-247-804-11	CARBON	75	5%	1/4W		R803	1-259-476-11	CARBON	100K	5%	1/6W	
R706	1-247-804-11	CARBON	75	5%	1/4W		R804	1-259-436-11	CARBON	2.2K	5%	1/6W	
R707	1-247-804-11	CARBON	75	5%	1/4W		R805	1-259-438-11	CARBON	2.7K	5%	1/6W	
R708	1-247-804-11	CARBON	75	5%	1/4W		R806	1-259-438-11	CARBON	2.7K	5%	1/6W	
R709	1-249-403-11	CARBON	68	5%	1/4W		R807	1-259-480-11	CARBON	150K	5%	1/6W	
R710	1-249-403-11	CARBON	68	5%	1/4W		R808	1-259-460-11	CARBON	22K	5%	1/6W	
R711	1-249-403-11	CARBON	68	5%	1/4W		R809	1-259-460-11	CARBON	22K	5%	1/6W	
R712	1-249-403-11	CARBON	68	5%	1/4W		R810	1-259-456-11	CARBON	15K	5%	1/6W	
R713	1-249-429-11	CARBON	10K	5%	1/4W		R811	1-259-414-11	CARBON	270	5%	1/6W	
R714	1-249-429-11	CARBON	10K	5%	1/4W		R812	1-259-414-11	CARBON	270	5%	1/6W	
R715	1-249-429-11	CARBON	10K	5%	1/4W		R813	1-259-436-11	CARBON	2.2K	5%	1/6W	
R716	1-249-429-11	CARBON	10K	5%	1/4W		R814	1-259-436-11	CARBON	2.2K	5%	1/6W	
R717	1-249-429-11	CARBON	10K	5%	1/4W		R815	1-259-480-11	CARBON	150K	5%	1/6W	

Ref.No	Part No.	Description				
R816	1-259-480-11	CARBON	150K	5%	1/6W	
R817	1-249-425-11	CARBON	4.7K	5%	1/4W	
R818	1-259-428-11	CARBON	1K	5%	1/6W	
R819	1-259-428-11	CARBON	1K	5%	1/6W	
R820	1-249-425-11	CARBON	4.7K	5%	1/4W	
R821	1-249-425-11	CARBON	4.7K	5%	1/4W	
R822	1-249-425-11	CARBON	4.7K	5%	1/4W	
R823	1-249-425-11	CARBON	4.7K	5%	1/4W	
R824	1-259-436-11	CARBON	2.2K	5%	1/6W	
R825	1-249-425-11	CARBON	4.7K	5%	1/4W	
R826	1-259-436-11	CARBON	2.2K	5%	1/6W	
R827	1-259-436-11	CARBON	2.2K	5%	1/6W	
R828	1-259-468-11	CARBON	47K	5%	1/6W	
R829	1-259-468-11	CARBON	47K	5%	1/6W	
R830	1-259-468-11	CARBON	47K	5%	1/6W	
R831	1-259-468-11	CARBON	47K	5%	1/6W	
R832	1-259-468-11	CARBON	47K	5%	1/6W	
R833	1-259-468-11	CARBON	47K	5%	1/6W	
R900	1-249-538-11	CARBON	270	5%	1/4W	
R901	1-259-452-11	CARBON	10K	5%	1/6W	
R902	1-259-452-11	CARBON	10K	5%	1/6W	
R903	1-259-452-11	CARBON	10K	5%	1/6W	
R906	1-259-428-11	CARBON	1K	5%	1/6W	
R908	1-259-476-11	CARBON	100K	5%	1/6W	
R909	1-259-452-11	CARBON	10K	5%	1/6W	
R910	1-249-489-11	CARBON	22K	5%	1/2W	
R911	1-259-428-11	CARBON	1K	5%	1/6W	
R912	1-259-428-11	CARBON	1K	5%	1/6W	
R913	1-259-476-11	CARBON	100K	5%	1/6W	
R914	1-259-476-11	CARBON	100K	5%	1/6W	
R915	△ 1-212-934-00	FUSIBLE	1	5%	1/2W	F
R916	△ 1-212-934-00	FUSIBLE	1	5%	1/2W	F
R917	△ 1-212-934-00	FUSIBLE	1	5%	1/2W	F
R918	1-259-440-11	CARBON	3.3K	5%	1/6W	
R919	△ 1-212-865-00	FUSIBLE	22	5%	1/4W	F
R920	1-259-452-11	CARBON	10K	5%	1/6W	
R921	1-259-476-11	CARBON	100K	5%	1/6W	
R922	1-259-404-11	CARBON	100	5%	1/6W	
R930	△ 1-217-481-00	FUSIBLE	10	5%	1W	F
R1001	1-249-401-11	CARBON	47	5%	1/4W	
R1001	1-249-418-11	CARBON	1.2K	5%	1/4W	
R1002	1-249-419-11	CARBON	1.5K	5%	1/4W	
R1003	1-249-419-11	CARBON	1.5K	5%	1/4W	
R1004	1-249-419-11	CARBON	1.5K	5%	1/4W	
R1005	1-249-418-11	CARBON	1.2K	5%	1/4W	
R1006	1-249-419-11	CARBON	1.5K	5%	1/4W	
R1007	1-249-419-11	CARBON	1.5K	5%	1/4W	
R1009	1-249-429-11	CARBON	10K	5%	1/4W	
R1010	1-249-417-11	CARBON	1K	5%	1/4W	
R1011	1-249-433-11	CARBON	22K	5%	1/4W	
R1012	1-249-405-11	CARBON	100	5%	1/4W	
R1013	1-249-409-11	CARBON	220	5%	1/4W	
R1014	1-249-393-11	CARBON	10	5%	1/4W	
R1015	1-249-429-11	CARBON	10K	5%	1/4W	
R1016	1-249-437-11	CARBON	47K	5%	1/4W	
R1017	1-247-895-00	CARBON	470K	5%	1/4W	
R1018	1-249-441-11	CARBON	100K	5%	1/4W	
R1019	1-249-417-11	CARBON	1K	5%	1/4W	
R1020	1-249-425-11	CARBON	4.7K	5%	1/4W	
R1021	1-249-441-11	CARBON	100K	5%	1/4W	
R1022	1-249-441-11	CARBON	100K	5%	1/4W	
R1023	1-249-441-11	CARBON	100K	5%	1/4W	
R1024	1-249-441-11	CARBON	100K	5%	1/4W	
R1025	1-249-441-11	CARBON	100K	5%	1/4W	
R1026	1-249-441-11	CARBON	100K	5%	1/4W	

Ref.No	Part No.	Description				
R1027	1-249-441-11	CARBON	100K	5%	1/4W	
R1028	1-249-441-11	CARBON	100K	5%	1/4W	
R1029	1-249-441-11	CARBON	100K	5%	1/4W	
R1030	1-249-441-11	CARBON	100K	5%	1/4W	
R1031	1-249-441-11	CARBON	100K	5%	1/4W	
R1032	1-249-441-11	CARBON	100K	5%	1/4W	
R1033	1-249-441-11	CARBON	100K	5%	1/4W	
R1034	1-249-439-11	CARBON	68K	5%	1/4W	
R1035	1-249-429-11	(UK, AEP, WG) ... CARBON	10K	5%	1/4W	
R1036	1-249-412-11	(UK, AEP, WG) ... CARBON	390	5%	1/4W	
RV101	1-238-248-11	RES, VAR, CARBON 20K/20K (INPUT LEVEL)				
RV102	1-237-886-11	RES, VAR, CARBON 100K/100K (INPUT BALANCE)				
RV103	1-238-248-11	RES, VAR, CARBON 20K/20K (INPUT LEVEL ANALOG)				
RV601	1-228-997-00	RES, ADJ, METAL GLAZE 100K				
RV651	1-228-997-00	RES, ADJ, METAL GLAZE 100K				
RV801	1-238-747-11	RES, VAR, CARBON 20KX5 (MASTER VOLUME)				
RV802	1-237-886-11	RES, VAR, CARBON 100K/100K (BALANCE)				
RV1001	1-466-203-11	ENCODER, ROTARY (DIGITAL PROCESSING CONTROL)				
RV1002	1-466-203-11	ENCODER, ROTARY (DIGITAL PROCESSING CONTROL)				
RY901	△ 1-515-617-11	(E, UK, AEP, WG) ... RELAY				
RY901	△ 1-515-701-11	(US, CND) ... RELAY				
RY903	1-515-614-11	RELAY				
S901	△ 1-572-609-11	(E) ... SELECTOR, VOLTAGE				
S1001	1-554-303-21	SWITCH, KEY BOARD (SURROUND MODE ▽ )				
S1002	1-554-303-21	SWITCH, KEY BOARD (PRESET/USER)				
S1003	1-554-303-21	SWITCH, KEY BOARD (SURROUND)				
S1004	1-554-303-21	SWITCH, KEY BOARD (DYNAMICS)				
S1005	1-554-303-21	SWITCH, KEY BOARD (PARAMETER EQ)				
S1006	1-554-303-21	SWITCH, KEY BOARD (SURROUND MODE △ )				
S1007	1-554-303-21	SWITCH, KEY BOARD (MAIN PARAMETER)				
S1008	1-554-303-21	SWITCH, KEY BOARD (SUB PARAMETER)				
S1009	1-554-303-21	SWITCH, KEY BOARD (EQ BAND)				
S1010	1-554-303-21	SWITCH, KEY BOARD (EQ SLOPE)				
S1011	1-554-303-21	SWITCH, KEY BOARD (MIX)				
S1012	1-554-303-21	SWITCH, KEY BOARD (DIGITAL)				
S1013	1-554-303-21	SWITCH, KEY BOARD (PHONO)				
S1014	1-554-303-21	SWITCH, KEY BOARD (TUNER)				
S1015	1-554-303-21	SWITCH, KEY BOARD (CD)				
S1016	1-554-303-21	SWITCH, KEY BOARD (MUTING)				
S1017	1-554-303-21	SWITCH, KEY BOARD (CHECK)				
S1018	1-554-303-21	SWITCH, KEY BOARD (SET)				
S1019	1-554-303-21	SWITCH, KEY BOARD (EFFECT REC)				
S1020	1-554-303-21	SWITCH, KEY BOARD (CHARACTER)				
S1021	1-554-303-21	SWITCH, KEY BOARD (CLEAR)				
S1022	1-554-303-21	SWITCH, KEY BOARD (ENTER)				
S1023	1-554-303-21	SWITCH, KEY BOARD (MEMORY)				
S1024	1-554-303-21	SWITCH, KEY BOARD (TEST TONE)				
S1025	1-554-303-21	SWITCH, KEY BOARD (PRO LOGIC MODE)				
S1026	1-554-303-21	SWITCH, KEY BOARD (TAPE 2)				
S1027	1-554-303-21	SWITCH, KEY BOARD (TAPE 1)				
S1028	1-554-303-21	SWITCH, KEY BOARD (TV)				
S1029	1-554-303-21	SWITCH, KEY BOARD (VDP)				
S1030	1-554-303-21	SWITCH, KEY BOARD (VIDEO 5)				
S1031	1-554-303-21	SWITCH, KEY BOARD (VIDEO 4)				
S1032	1-554-303-21	SWITCH, KEY BOARD (VIDEO 3)				
S1033	1-554-303-21	SWITCH, KEY BOARD (VIDEO 2)				
S1034	1-554-303-21	SWITCH, KEY BOARD (VIDEO 1)				
S1035	1-554-303-21	SWITCH, KEY BOARD (DIGITAL +)				
S1036	1-554-303-21	SWITCH, KEY BOARD (DIGITAL -)				

**Note:**  
The components identified by mark △ or dotted line with mark △ are critical for safety. Replace only with part number specified.

**Note:**  
Les composants identifiés par une marque △ sont critiques pour la sécurité. Ne les remplacer que par une pièce portant le numéro spécifié.

<u>Ref.No</u>	<u>Part No.</u>	<u>Description</u>
S1037	1-554-303-21	SWITCH, KEY BOARD (DISPLAY)
S1038	1-554-303-21	SWITCH, KEY BOARD (DIMMER)
S1050	1-554-303-21	SWITCH, KEY BOARD (POWER)
T901	△ 1-449-835-11	(US, CND)... TRANSFORMER, POWER
T901	△ 1-449-881-11	(AEP, WG)... TRANSFORMER, POWER
T901	△ 1-449-882-11	(UK)... TRANSFORMER, POWER
T901	△ 1-449-883-11	(E)... TRANSFORMER, POWER
T902	△ 1-421-960-11	TRANSFORMER, LINE FILTER
X301	1-577-269-11	VIBRATOR, CRYSTAL (18.432MHz)
X502	1-577-305-11	VIBRATOR, CRYSTAL (25MHz)
X1001	1-567-797-11	VIBRATOR, CERAMIC
X1002	1-577-101-11	VIBRATOR, CERAMIC (4.19MHz)

<u>Ref.No</u>	<u>Part No.</u>	<u>Description</u>
ACCESSORIES & PACKING MATERIALS		
*****		
	1-465-294-11	REMOTE COMMANDER (RM-P1000)
	1-526-565-00	(E)... AC PLUG ADAPTOR
	1-558-271-11	(E, UK, AEP, WG)... CORD, CONNECTION
	1-559-533-11	(US, CND)... CORD, CONNECTION
*	2-135-414-01	SHEET, PROTECTION
	3-703-450-01	(US)... INSTRUCTION
	3-704-366-01	(E, AEP, WG)... SCREW (CASE) (M3X8)
	3-704-366-31	(US, CND, UK)... SCREW (CASE) (M3X6)
	3-750-791-11	(E, UK, AEP)... MANUAL, INSTRUCTION
	3-750-791-21	(US, CND)... MANUAL, INSTRUCTION
	3-750-791-31	(CND)... MANUAL, INSTRUCTION
	3-750-791-41	(AEP, WG)... MANUAL, INSTRUCTION
	4-915-702-01	LABEL, CAUTION, DOLBY SURROUND
*	4-933-001-01	CUSHION
*	4-933-429-01	(US, CND)... LABEL, MODEL NUMBER (U)
*	4-933-432-01	INDIVIDUAL CARTON

<p><b>Note:</b> The components identified by mark △ or dotted line with mark △ are critical for safety. Replace only with part number specified.</p>	<p><b>Note:</b> Les composants identifiés par une marque △ sont critiques pour la sécurité. Ne les remplacer que par une pièce portant le numéro spécifié.</p>
--	--

# TA-E1000ESD

## **SONY<sup>®</sup>** **SERVICE MANUAL**

*US Model*  
*Canadian Model*  
*AEP Model*  
*UK Model*  
*E Model*

## **SUPPLEMENT-1**

**SUBJECT : BLOCK DIAGRAMS**

File this supplement with the Service Manual.



# SECTION 3 DIAGRAMS

## 3-9. BLOCK DIAGRAM —ANALOG SECTION—

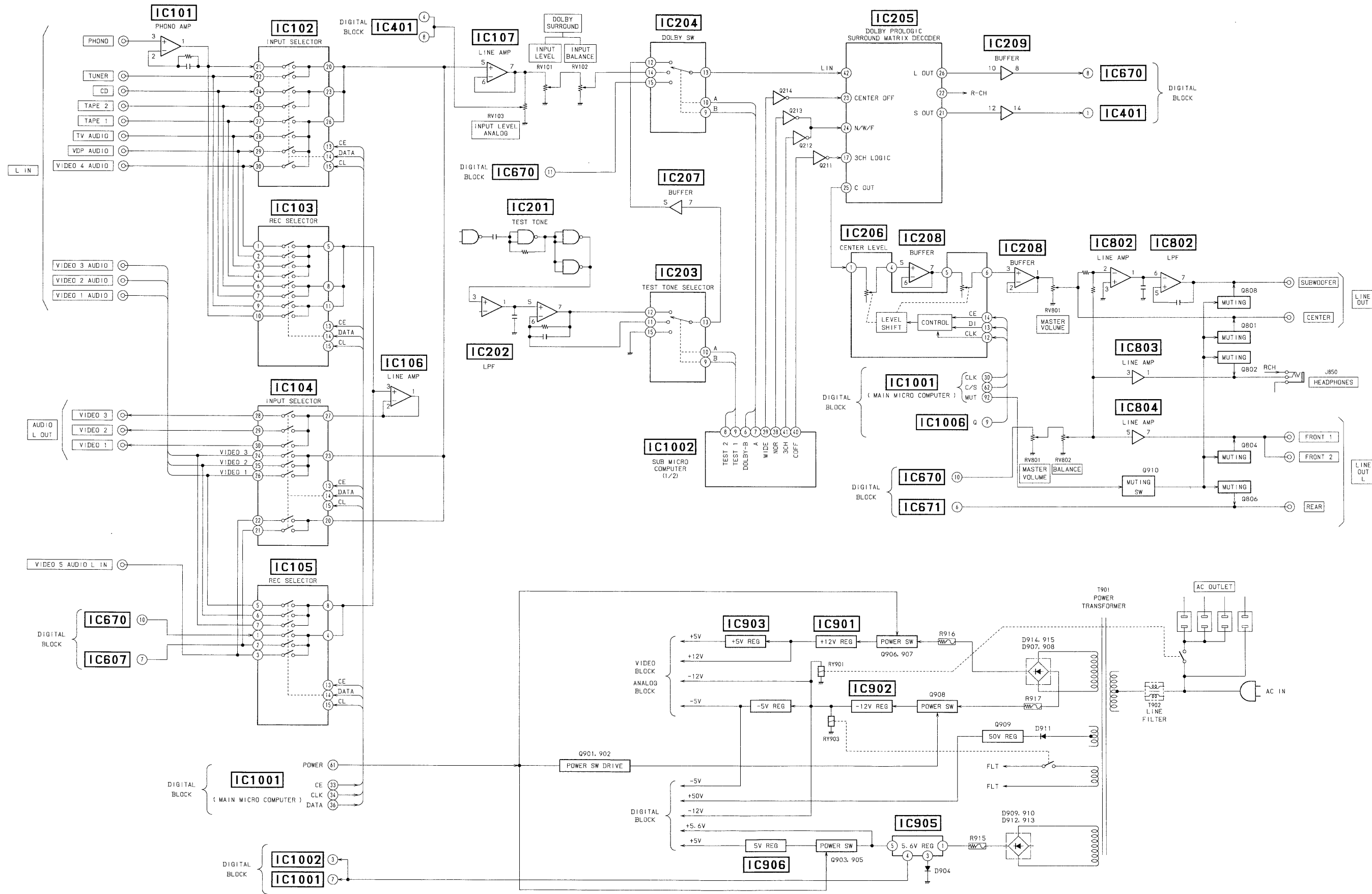



3-10. BLOCK DIAGRAM —DIGITAL SECTION—

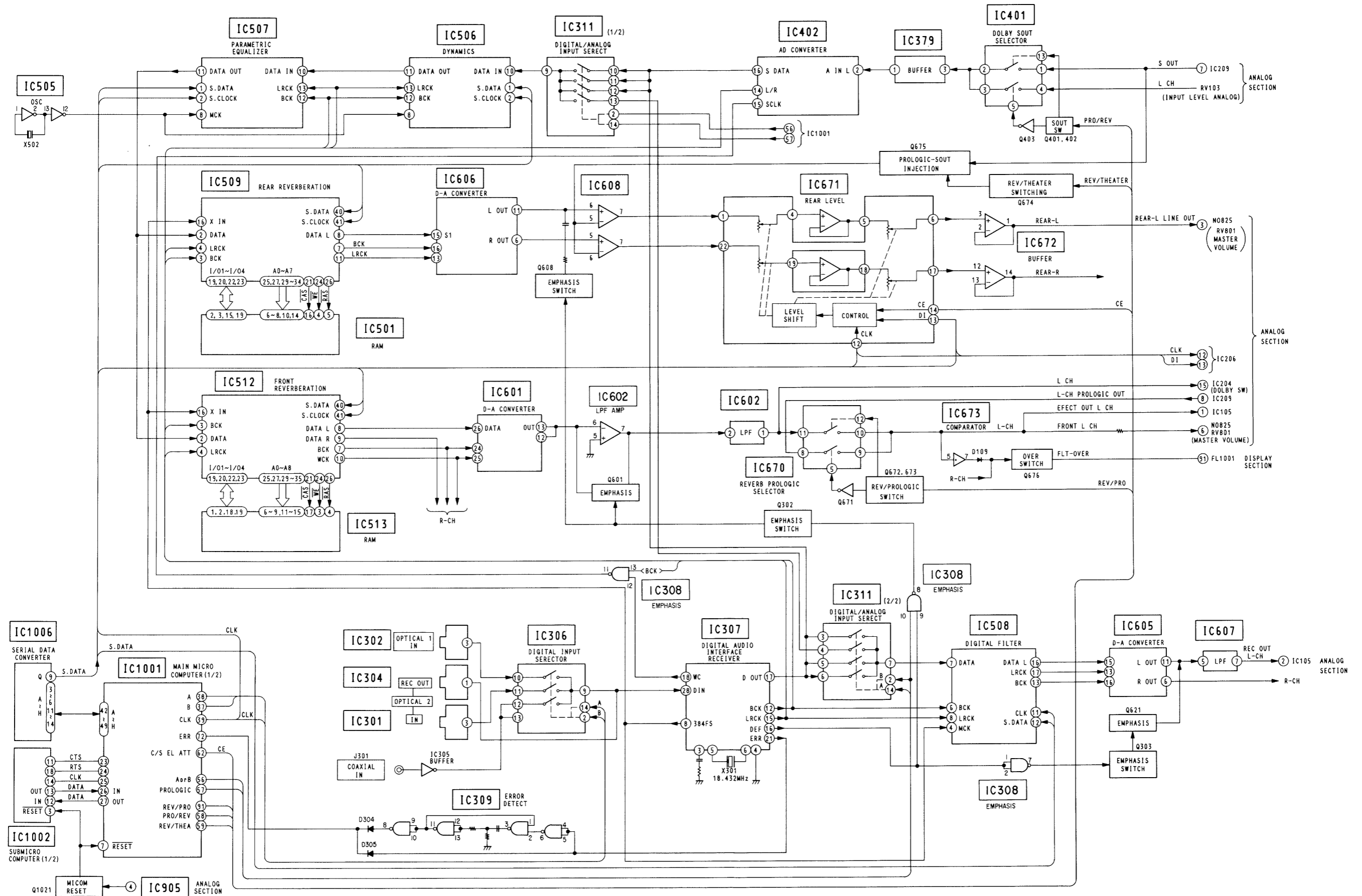

3-11. BLOCK DIAGRAM —VIDEO/DISPLAY SECTION—

