

TA-E2000ESD

SERVICE MANUAL

*US Model
Canadian Model
AEP Model
E Model*

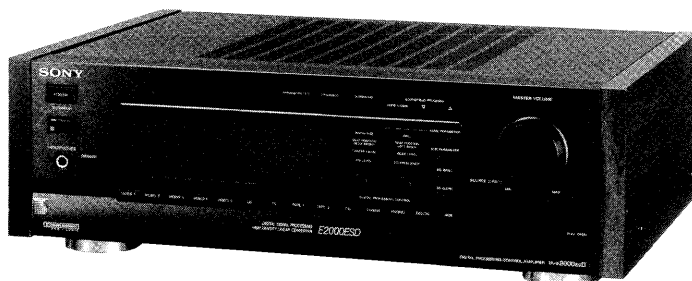

SPECIFICATION

Amplifier section

Frequency response (Parametric EQ, Dynamics, Surround: OFF)

Other than PHONO
Front, Center*, Rear:
10 Hz – 20kHz ± 0.1 dB
Subwoofer: Cut off 80 Hz, 18 dB/oct.
PHONO
VIDEO 1 – 3 AUDIO OUT, TAPE1, 2
REC OUT: 20 Hz – 20 kHz ± 0.2 dB

Input sensitivity and input impedance

PHONO (MM): 5 mV, 50 kohms
TUNER, CD, TAPE1, 2, VIDEO 1 – 5,
LD, TV: 250 mV, 50 kohms
DIGITAL OPTICAL 1, 2: None
DIGITAL COAXIAL: 0.5 Vp-p $\pm 20\%$
75ohms

S/N

PHONO
Front, Center, Rear: 84 dB (A)
TUNER, CD, TAPE1, 2, VIDEO 1 – 5,
LD, TV
Front, Center, Rear: 94 dB (A)
DIGITAL (OPTICAL 1, 2, COAXIAL)
Front, Center, Rear: 103 dB (A)

Residual noise

Below 10 μ V (A)

Output voltage and output impedance

VIDEO 1 – 3 AUDIO OUT, TAPE, 1, 2
REC OUT: 250 mV, 470 ohms
FRONT, CENTER, REAR,
SUBWOOFER: 2.5 V
DIGITAL OPTICAL 2: None
DIGITAL COAXIAL: 0.5 Vp-p $\pm 20\%$,
75 ohms
HEADPHONES: 25 mW (at 8 ohms);
accepts low and high impedance
headphones

Total harmonic distortion

Analog input
Front: below 0.004% at 1 kHz
Digital input
Front: below 0.003% at 1 kHz

* When the PRO LOGIC MODE button is set to WIDE in Dolby SURROUND Mode.

Video section

Video input sensitivity and input impedance

VIDEO IN
VIDEO 1 – 5, LD, TV: 1 Vp-p, 75 ohms
S VIDEO IN
VIDEO1, 2, 5
Luminance (Y): 1 Vp-p, 75 ohms
Chroma (C): 0.286 Vp-p, 75 ohms

Video output voltage and output impedance

VIDEO OUT
VIDEO 1 – 3, MONITOR1, 2: 1 Vp-p,
75 ohms
S VIDEO OUT
VIDEO 1, 2, MONITOR
Luminance (Y): 1Vp-p, 75 ohms
Chroma (C): 0.286 Vp-p, 75 ohms

Digital signal processor section

Parametric equalizer 3-band
Center frequency: 18 Hz – 20 kHz,
1/9 oct.-step
Level: ± 12 dB, 0.1 dB-step
Slope (Q): 16-steps

—continued on next page—

DIGITAL PROCESSING CONTROL AMPLIFIER
SONY®



Dynamics	Compressor: 1 – 9, 1-step Expander: 1 – 9, 1-step
Surround	Main parameter Room size: 0.5 – 2.0, 0.1-step Wall: 0.5 – 2.0, 0.1-step Seat position: F50-0-R50, L50-0-R50 1-step Sub parameter Early reflection time: 2 – 500 mS**; 2mS-step Early reflection level: 0 – 100%, 1%-step Reverb time: 0.3 – 5.0S, 0.1 S-step PRO LOGIC DECODER: ON, OFF Separation control: 0 – 10, 1-step Effect level: 0 – 100%, 1%-step Delay time: 15.0 – 30.0 mS, 0.1 mS-step

** When Room=2.0, this is adjustable up to 500 mS

A/D, D/A converter section

A/D converter	Type: High density linear converter system Sampling frequency: 48 kHz
D/A converter	Front: Advanced pulse D/A converter system Center: Advanced pulse D/A converter Rear: Advanced pulse D/A converter Sampling frequency: 32 kHz, 44.1 kHz, 48 kHz

General

Power requirements	AEP, Germany model: 220 V AC (or 240 V AC adjustable by authorized Sony personnel) 50/60Hz US, Canadian model: AC 120V, 60Hz E model: 120V, 220V, and 240V AC adjustable, 50/60Hz
--------------------	--

Power consumption	38 watts
AC outlets	Switzerland: Not equipped Other European countries: 1 switched, 500 watts Countries other than Europe: 3 switched, total 500 watts 1 unswitched, 300 watts

Dimensions	Approx. 470 × 150 × 355 mm (18 1/2 × 6 × 14 inches) (w/h/d) including projecting parts and controls. Width when removing the side panels: 430 mm (17 inches)
------------	--

Weight	Approx. 8.5 kg (18 lb 12oz)
--------	-----------------------------

Supplied accessories	Programmable remote commander RM-P2000 (1) Sony Batteries SUM-3 (NS) (2) Audio connecting cord (3) Screw (4)
----------------------	--

Design and specifications are subject to change without notice.

Note

This appliance conforms with EEC Directive 87/308/EEC regarding interference suppression.

TABLE OF CONTENTS

<u>Section</u>	<u>Title</u>	<u>Page</u>
1. GENERAL		
1-1.	Functions of Controls	3
2. DIAGRAMS		
2-1.	Circuit Boards Location	6
2-2.	Printed Wiring Boards—Digital Section—	7
2-3.	Schematic Diagram—Digital Section—	9
2-4.	Semiconductor Lead Layouts	13
2-5.	Printed Wiring Boards—Analog Section—	14
2-6.	Schematic Diagram—Analog Section—	17
2-7.	Schematic Diagram—Video, Display Section—	21
2-8.	Printed Wiring Boards—Video, Display Section—	25
3. EXPLODED VIEWS		
3-1.	Chassis, Main Board Section	33
3-2.	Front Panel Section	35
4. ELECTRICAL PARTS LIST		36

MODEL IDENTIFICATION

—Specification Label—

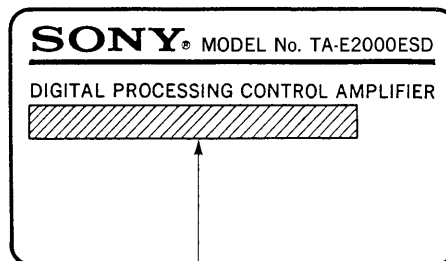

US, Canadian Model: AC 120V 60Hz 38W
AEP, Germany (G) Model: AC 220—230V~50/60Hz
E model: AC 120/220/240V~50/60Hz 38W

SAFETY-RELATED COMPONENT WARNING!!

COMPONENTS IDENTIFIED BY MARK OR DOTTED LINE WITH MARK ON THE SCHEMATIC DIAGRAMS AND IN THE PARTS LIST ARE CRITICAL TO SAFE OPERATION. REPLACE THESE COMPONENTS WITH SONY PARTS WHOSE PART NUMBERS APPEAR AS SHOWN IN THIS MANUAL OR IN SUPPLEMENTS PUBLISHED BY SONY.

ATTENTION AU COMPOSANT AYANT RAPPORT À LA SÉCURITÉ!

LES COMPOSANTS IDENTIFIÉS PAR UNE MARQUE SUR LES DIAGRAMMES SCHÉMATIQUES ET LA LISTE DES PIÈCES SONT CRITIQUES POUR LA SÉCURITÉ DE FONCTIONNEMENT. NE REMPLACER CES COMPOSANTS QUE PAR DES PIÈCES SONY DONT LES NUMÉROS SONT DONNÉS DANS CE MANUEL OU DANS LES SUPPLÉMENTS PUBLIÉS PAR SONY.

SECTION 1 GENERAL

This section is extracted from instruction manual.

1-1. FUNCTIONS OF CONTROLS

Front Panel

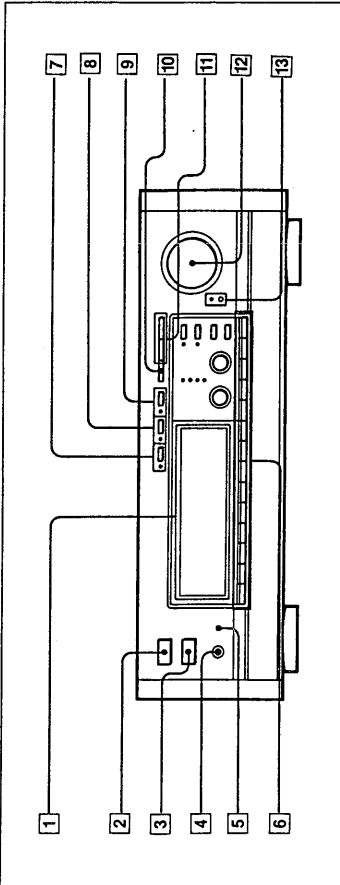

- 1** Display
- 2** POWER switch
Press to turn on the amplifier and the equipment connected to the SWITCHED outlets. Press again to turn off.
- 3** Remote control sensor
- 4** HEADPHONES jack
Accepts the stereo phone plug of headphones. The jack outputs the sound of the front speakers only. To listen to the program source only with the headphones, turn off each power amplifier or set the speaker select switch on each amplifier to OFF.
- 5** DIMMER button (page 32)
Adjusts the brightness of the display to one of three levels. You can also use this button to check which parameter can be adjusted.
- 6** Input select buttons and MIX button (page 26)
Select the desired program source.
- 7** PARAMETRIC EQ button and indicator (pages 32 and 41)
Turns on and off the parametric equalizer. When the parametric equalizer is on, the indicator lights.
- 8** DYNAMICS button and indicator (pages 32 and 40)
Turns on and off the dynamics function. When the dynamics function is on, the indicator lights.
- 9** SURROUND button and indicator (pages 32 and 34)
Turns on and off the surround function. When the surround function is on, the indicator lights.
- 10** PRESET/USER button (page 44)
Selects either the sound field preset at the factory or sound field preset by the user.
- 11** SOUNDFIELD PROGRAM buttons (page 29)
Selects the desired sound field.
- 12** MASTER VOLUME knob (page 26)
Controls the audio level from LINE OUT and HEADPHONES jacks.
- 13** SOURCE DIRECT button and indicator (page 31)
Directly outputs the program source sound without passing through the parametric equalizer, dynamics and surround circuitry. Rear and center outputs are disconnected and signals are output from the front and subwoofer. Press the button again to release. In EFFECT REC mode, if the SOURCE DIRECT button is pressed, EFFECT REC mode will be released.

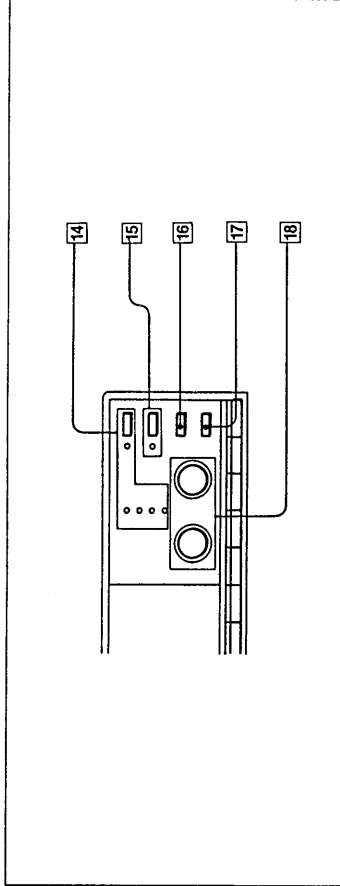

- 14** MAIN PARAMETER button and indicators (pages 34, 35, 36 and 41)
Selects the pair of main parameters to be set. The indicator lights when the main parameters can be set.
- 15** SUB PARAMETER button and indicator (pages 37 and 40)
Selects the sub parameter to be set. The indicator lights when the displayed sub parameter can be set.
- 16** EQ BAND select button (page 41)
Selects the desired band of the parametric equalizer.
- 17** EQ SLOPE select button (page 41)
Selects the desired slope (Q) of the parametric equalizer.
- 18** DIGITAL PROCESSING CONTROL knobs
Set the parameters.

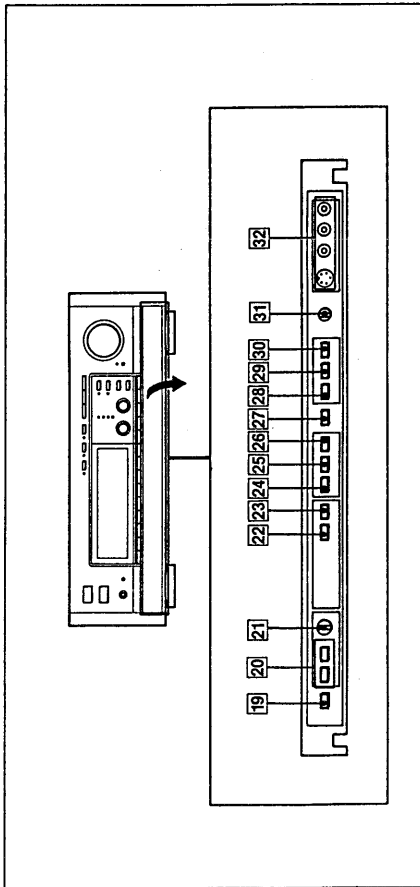

- 18 PRO LOGIC MODE button (page 20)
Selects the operation mode of Dolby Pro Logic surround function.
- 20 DIGITAL input level buttons (page 24)
Adjusts the input level connected to the digital input jacks. Keep pressing + until just before **OVER** appears in the display.
- 21 ANALOG input level knob (page 24)
Adjusts the input level of analog inputs. Turn the knob clockwise until just before **OVER** appears in the display.
- 22 EQ CH (equalizer channel) button (pages 41 and 42)
Selects the channel (front, center, rear or all the channels) to be adjusted by the parametric equalizer.
- 23 FLAT button (page 42)
Makes the channel equalizer curve being displayed be flat.
- 24 MEMORY button (pages 28 and 43)
Stores the parameter settings and digital input assignment.
- 25 ENTER button (pages 43 and 45)
Stores parameter settings or stores the title written.
- 26 CLEAR button (page 28)
Clear the digital equipment assigned to an input select button.
- 27 CHARACTER button (page 45)
Writes a title for an input select button or a sound field.
- 28 EFFECT REC (record) button (page 31)
Outputs the digitally-processed signals to the analog recording output jacks (AUDIO OUT and REC OUT). These signals are not output to the digital recording output jack (OPTICAL 2). When this button is set to ON, the SET button does not activate.
- 29 SET button (page 47)
Sets the desired program source for recording while you are listening to or watching another program source.
- 30 CHECK button (pages 46 and 47)
Displays the program source to be recorded which is selected by the SET button. Checks the former label on the sound field.
- 31 BALANCE control knob
Adjusts the balance between the left and right front speakers. Generally, set the knob at the center position.
- 32 VIDEO 5 INPUT jacks (page 9)
Accept S-video/VIDEO and audio input signals.

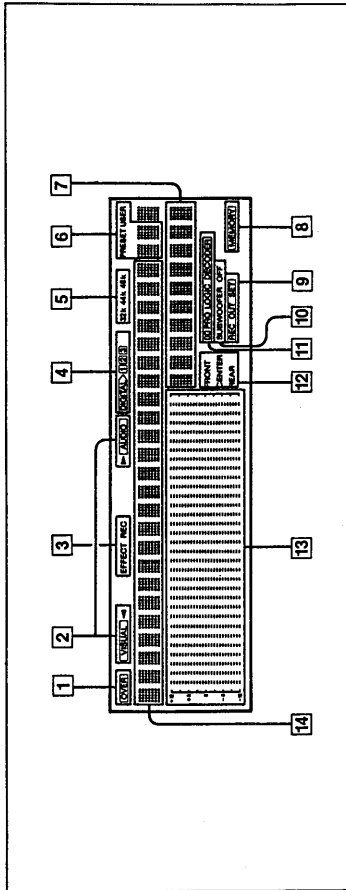

- 1 OVER Indication
Lights when the input level is so high that the circuit clips.
- 2 VISUAL </> AUDIO Indications
Indicate either visual input or audio input to be selected when mixing them.
- 3 EFFECT REC Indication
Lights when the EFFECT REC button is pressed to make an effect recording.
- 4 DIGITAL 1 2 3 Indication
Indicates the digital input selected by the DIGITAL button.
- DIGITAL 1 : Input to the OPTICAL 1 IN jack in the rear panel is selected.
- DIGITAL 2 : Input to the OPTICAL 2 IN jack is selected.
- DIGITAL 3 : Input to the COAXIAL IN jack is selected.
- 5 Sampling frequency indicator
Indicates the sampling frequency of the digital signal input. (For example, in the case of a CD, 44k is indicated.)
- 6 PRESET/USER sound field number indication
Indicates the number of the PRESET/USER select button setting or the number of the sound field.
- 7 Sound field name indication
Indicates the sound field name selected.
- 8 MEMORY Indication
Appears when you press the USER button to store the parameter settings. When designating the sound field number to be stored and pressing the ENTER button, the MEMORY Indication disappears showing that the storing has been complete. (In the case of the remote commander, the MEMORY Indication appears when you press the MEMORY button and disappears when you press the sound field number button.)
- 9 REC-OUT/SET Indication
Appears when the SET button is pressed and disappears when the SET button is pressed again.
- 10 SUBWOOFER OFF Indication
Lights when the subwoofer output is muted by the remote commander.
- 11 PRO LOGIC DECODER Indication
Lights when the Pro Logic Decoder is used.
- 12 FRONT CENTER REAR Indication
Indicates the FRONT, CENTER or REAR channel whose tone quality is to be adjusted.
- 13 Equalizer curve Indication
Indicates the equalizer curve.
- 14 Character Indication
Indicates a sound field name, program source, operation mode or warning concerning incorrect operation.
When the line output signals are muted, MUTING ON is indicated.

Programmable Remote Commander RM-P2000

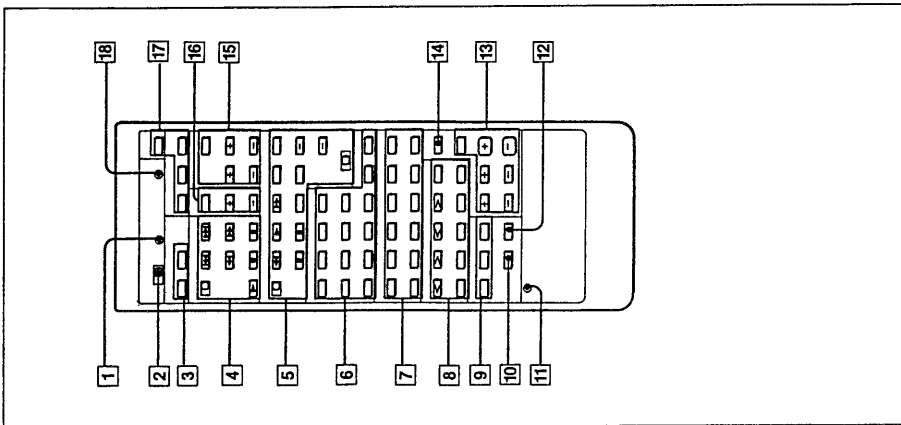

The RM-P2000 can "learn" various functions of other remote control units which use infrared rays. When the mode selector is set to SONY STD (Sony standard), you can use the buttons on the RM-P2000 to perform the functions as follows.

- 1 LEARN indicator (page 48)
is used to confirm operation when storing the signals of other remote control units.
- 2 Mode selector (page 48)
SONY STD: To control Sony equipment.
USER STD: To control the equipment whose remote control functions are stored.
LEARN: To store functions of other remote control units that use infrared rays.
- 3 DISPLAY buttons
MODE (display mode) button
Selects the display in the following order.
All indications are displayed→Name of equipment being input is displayed→Only the MASTER VOLUME indicator lights (When operating other buttons or knobs, their indications light automatically for several seconds.)→All indications are displayed.
DIMMER button
Adjusts the brightness of the display to one of three levels.
- 4 GDI/PDLP control button (page 48)
GDI/PDLP selector: Selects the equipment to be controlled.
: Play
: Pause
: Stop
: AMS (Automatic Music Sensor)—
Locates a desired selection
: Search (for LD player only)
- 5 TAPE/VTR control buttons (page 48)
TAPE/VTR selector: Selects the equipment to be controlled.
: Playback
: Pause
: Stop
: Rewind
: Fast forward
: Record (Press this button together with the button to the right of this button to start recording)
You can use the following buttons when the TAPE/VTR selector is set to VTR.
DUAL : Selects bilingual programs.
ANT-TV/VTR : Selects output signal from the antenna terminal on the VCR.
CH +/- : Selects a higher or lower preset channel.
VTR selector : Selects VCR 1, 2 or 3.
- 6 Input select buttons: Work in the same way as buttons on the main unit. (page 26)

- 7 Sound field buttons (page 29)
PRESET/USER: Selects either the sound fields preset at the factory or the sound fields preset by the user.
MEMORY button: Stores the parameter setting and digital input assignment.
Sound field select buttons (1-10): Select a desired sound field.
- 8 Parameter control buttons: Work in the same way as the buttons on the main unit.
DIGITAL PROCESSING CONTROL button
MAIN PARAMETER button
SUBPARAMETER button
EQUALIZER CH (channel) button
EQUALIZER BAND button
EQUALIZER SLOPE button
EQUALIZER FLAT button
- 9 Digital sound processing buttons: Work in the same way as the buttons on the main unit.
PARAMETRIC EQ (equalizer) button
DYNAMICS button
SURROUND button
- 10 TEST TONE button (page 22)
Turns on and off the test tone to adjust the balance among the front, center and rear speakers.
- 11 RESET button (page 49)
is used when the remote commander does not work correctly.
- 12 SUB WOOFER button
Mutes the subwoofer outputs. SUB WOOFER OFF appears on the display. Press again to release.
- 13 Volume control buttons
MASTER VOL +/- : Adjust the level of the LINE OUT and HEADPHONES jacks.
REAR VOL +/- : Adjust the level of the rear speakers.
CENTER VOL +/- : Adjust the level of the center speakers.
MUTING : Mutes the line outputs. MUTING ON appears in the display.
Press again to release.
- 14 SOURCE DIRECT button
Directly outputs the program source sound without passing through the parametric equalizer, dynamics and surround. Rear and center outputs are disconnected and signals are output from the front and subwoofer. Press the button again to release.
During EFFECT REC mode, when you press the SOURCE DIRECT button, EFFECT REC mode will be released.
- 15 TV control buttons
TV/VIDEO: Selects the input to the TV.
VOL +/-: Adjust the volume.
CH +/-: Select the preset channel.
- 16 Tuner control buttons
BAND: Selects the frequency band.
PRESET +/-: Select the preset number.
- 17 Power buttons
POWER: Turns this amplifier and the equipment connected to the SWITCHED outlets on and off.
- TV POWER: Turns the TV on and off.
VTR POWER: Turns the VCR selected by the VTR 1, 2, 3 selector switch on and off.
(Works only when the TAPE/VTR selector is set to VTR.)
LDP POWER: Turns the LD player on and off.
- 18 PROGRAM CLEAR button (page 49)
Clears all the stored signals.

SECTION 2
DIAGRAMS

2-1. CIRCUIT BOARDS LOCATION

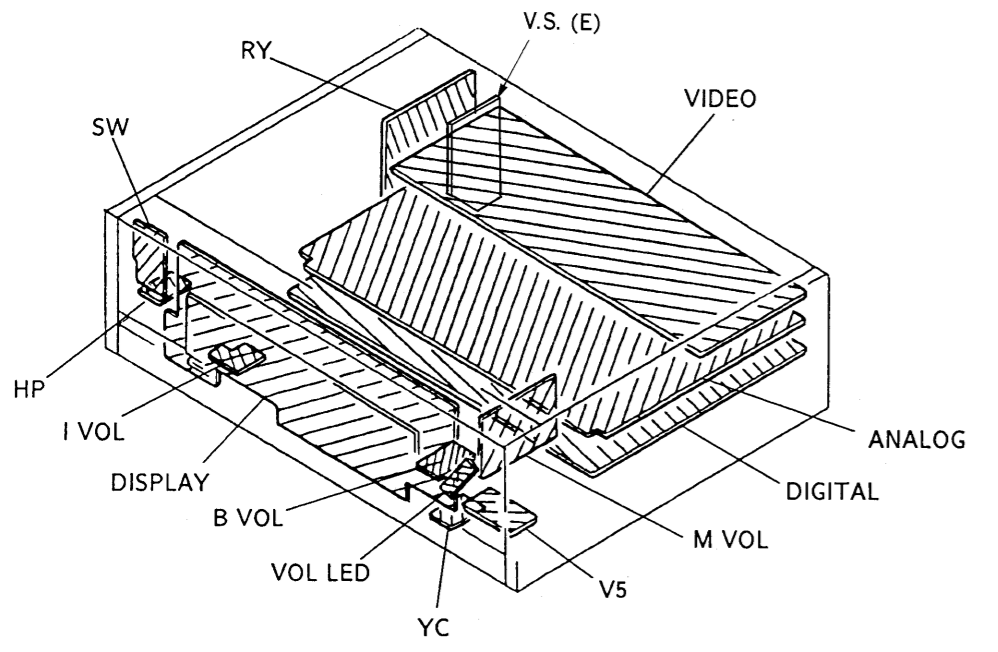

• Semiconductor Location

Ref. No.	Location	Ref. No.	Location
D301	D-4	IC416	H-6
D304	F-7	IC417	D-10
D305	G-8	IC418	D-6
D306	D-8	IC419	D-10
D307	D-8	IC420	C-8
D308	E-12	IC421	D-7
D403	B-11	IC501	H-8
D501	G-8	IC502	H-9
D1014	C-12	IC503	H-11
D1015	D-12	IC504	J-4
D1016	B-12	IC552	I-9
D1018	C-13	IC553	I-11
D1019	C-13	IC601	H-5
D1020	D-13	IC602	I-3
D1021	D-13	IC603	I-2
D1022	D-13	IC651	J-5
D1023	J-12	IC652	H-3
D1024	F-14	IC653	H-2
D1025	F-14	IC673	J-2
D1050	I-16	IC762	J-3
IC301	A-4	IC1001	D-12
IC302	A-5	IC1002	I-13
IC304	A-3	IC1006	J-10
IC305	C-2	IC1050	I-16
IC306	B-10	Q301	E-3
IC307	C-5	Q303	G-7
IC309	D-9	Q304	G-6
IC310	F-8	Q305	F-8
IC311	F-8	Q1001	I-14
IC312	G-6	Q1002	I-14
IC313	F-5	Q1003	I-14
IC314	D-4	Q1004	I-13
IC315	E-2	Q1005	I-13
IC316	B-6	Q1006	I-13
IC401	F-3	Q1007	I-13
IC402	F-4	Q1008	I-13
IC404	E-4	Q1009	I-13
IC405	E-4	Q1010	I-12
IC406	B-10	Q1011	C-12
IC410	F-10	Q1012	B-12
IC411	G-11	Q1013	B-12
IC412	I-8	Q1014	B-13
IC413	J-7	Q1015	B-11
IC414	G-9	Q1031	J-16
IC415	I-6	Q1032	J-16

Note:
 ● — : parts extracted from the component side.
 ● ■ : parts mounted on the conductor side.
 ● G : Germany model

2-2. PRINTED WIRING BOARDS—DIGITAL SECTION— • Refer to page 13 for Semiconductor Lead Layouts.

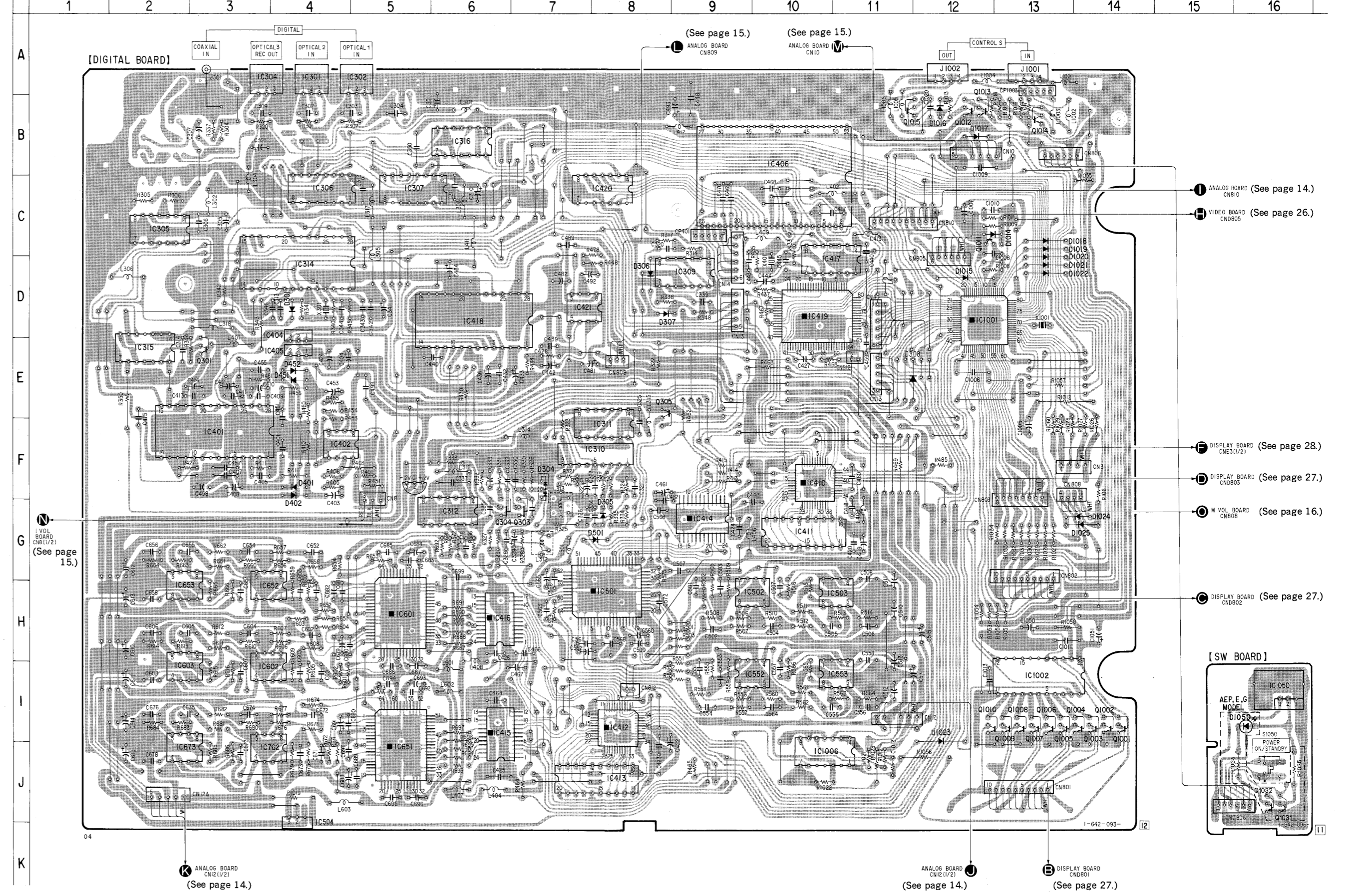

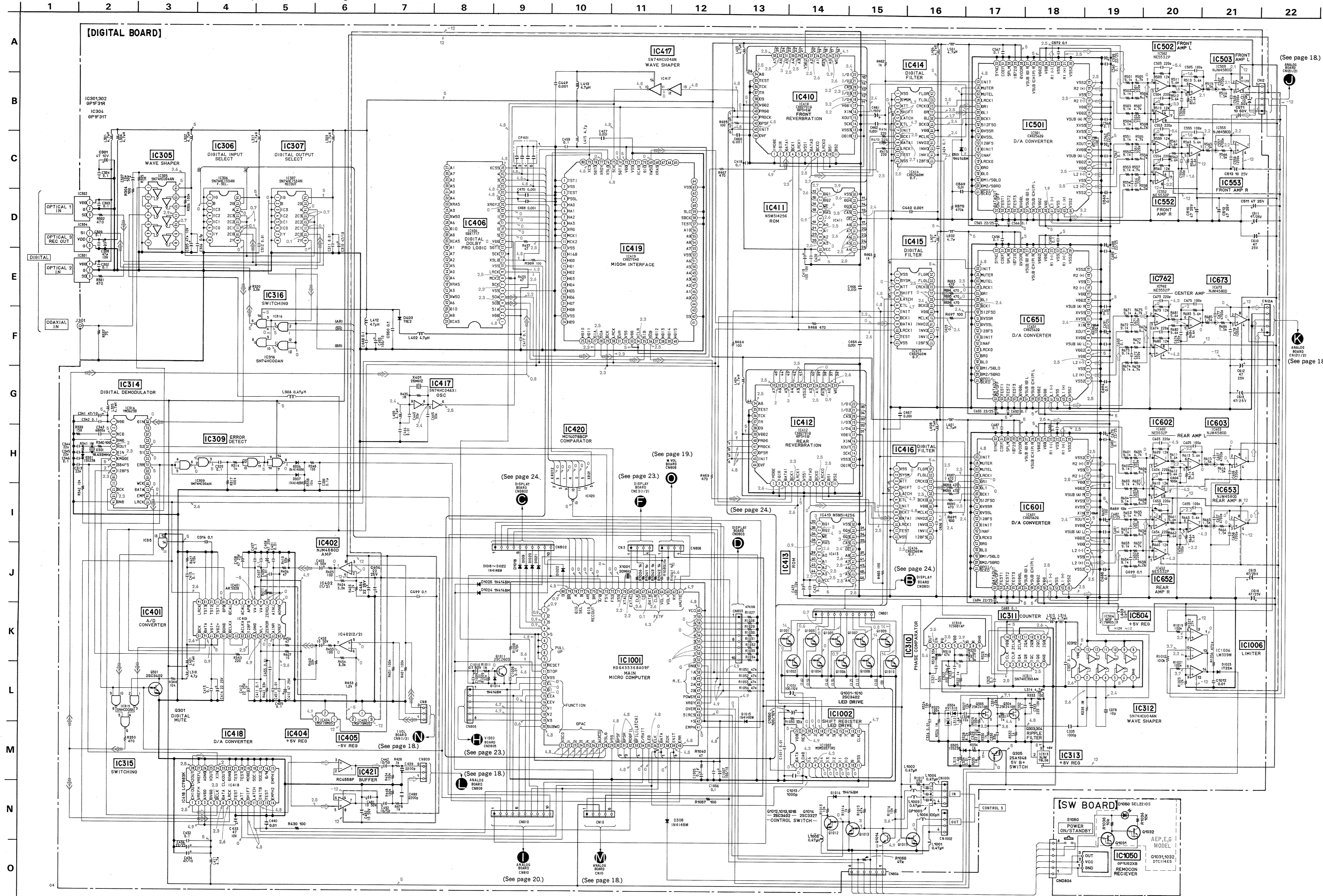

Note:

- All capacitors are in μF unless otherwise noted. pF : μF 50WV or less are not indicated except for electrolytics and tantalums.
- All resistors are in Ω and $\frac{1}{2}\text{W}$ or less unless otherwise specified.
- \triangle : internal component.
- --- : B+ Line
- --- : B- Line
- Voltage is dc with respect to ground under no-signal conditions. no mark: PHONO
- Voltages are taken with a VOM (input impedance $10\text{M}\Omega$). Voltage variations may be noted due to normal production tolerances.
- Signal path.
 - --- : analog signal
 - --- : digital signal
 - --- : PHONO
 - --- : Germany model

2-4. SEMICONDUCTOR LEAD LAYOUTS

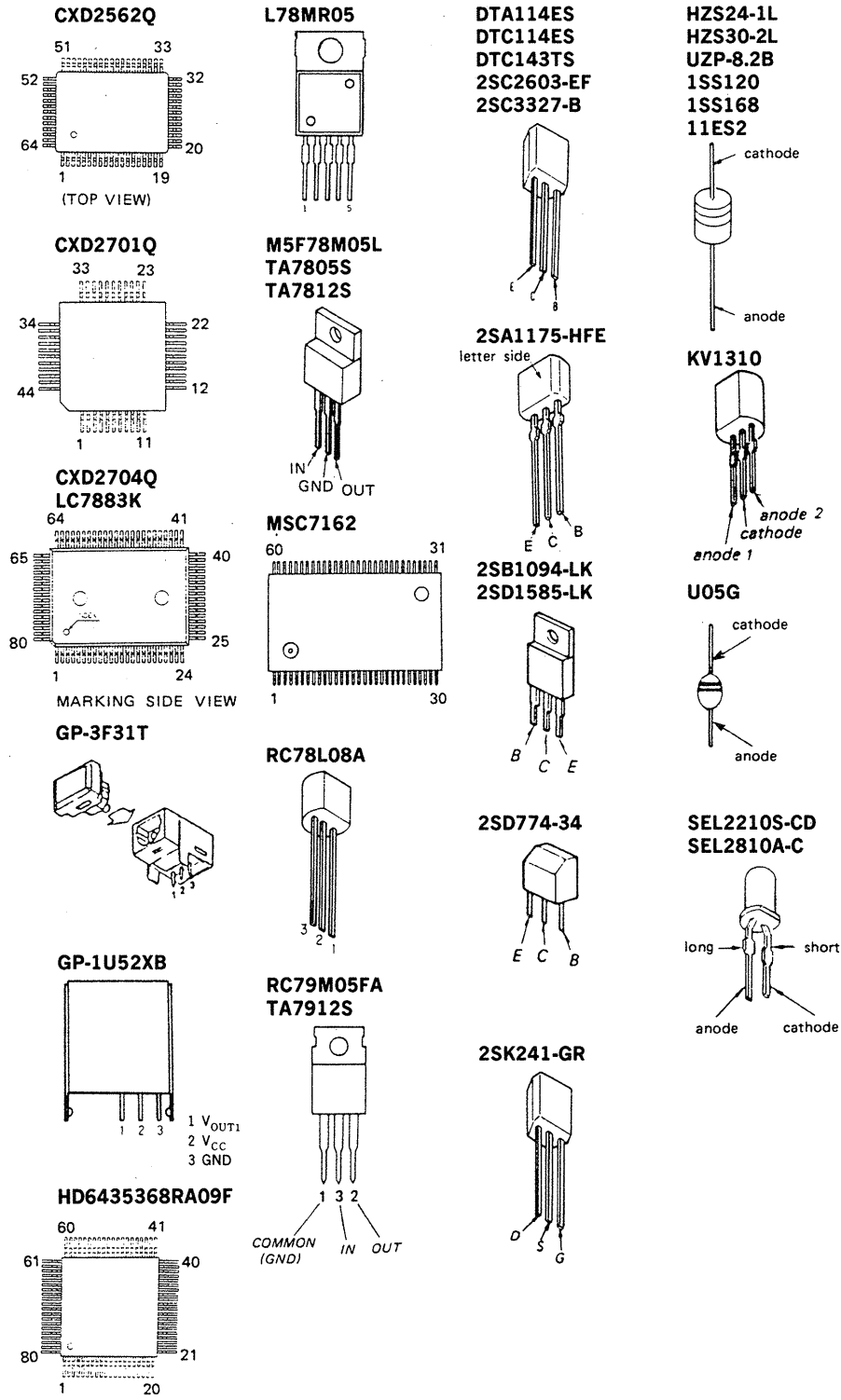

● Semiconductor Location

Ref. No.	Location
D801	C-13
D802	C-13
D803	C-12
D804	K-7
D805	K-7
D901	E-11
D902	I-10
D904	I-9
D905	I-14
D906	I-13
D907	G-14
D908	G-13
D909	J-14
D910	J-14
D911	H-14
D912	I-14
D913	I-14
D914	F-14
D915	F-13
D916	I-13
D917	J-9
D918	J-10
D1051	J-17
IC101	C-2
IC102	C-5
IC103	D-5
IC104	C-9
IC105	D-9
IC106	E-7
IC107	E-7
IC801	A-23
IC802	D-13
IC803	E-12
IC804	D-12
IC805	G-4
IC806	G-5
IC807	I-4
IC808	I-5
IC809	G-6
IC901	H-10
IC902	I-11
IC903	H-9
IC904	I-10
IC905	K-13
IC906	J-11
Q801	B-14
Q802	E-14
Q803	C-14
Q804	E-13
Q805	F-12
Q806	F-13
Q807	H-3
Q808	I-3
Q809	I-3
Q901	G-9
Q902	G-9
Q903	J-12
Q905	J-12
Q906	G-12
Q907	G-12
Q908	H-12
Q909	H-13

Note:
 ● — : parts extracted from the component side.
 ● CND : Canadian model
 ● G : Germany model

2-5. PRINTED WIRING BOARDS—ANALOG SECTION—

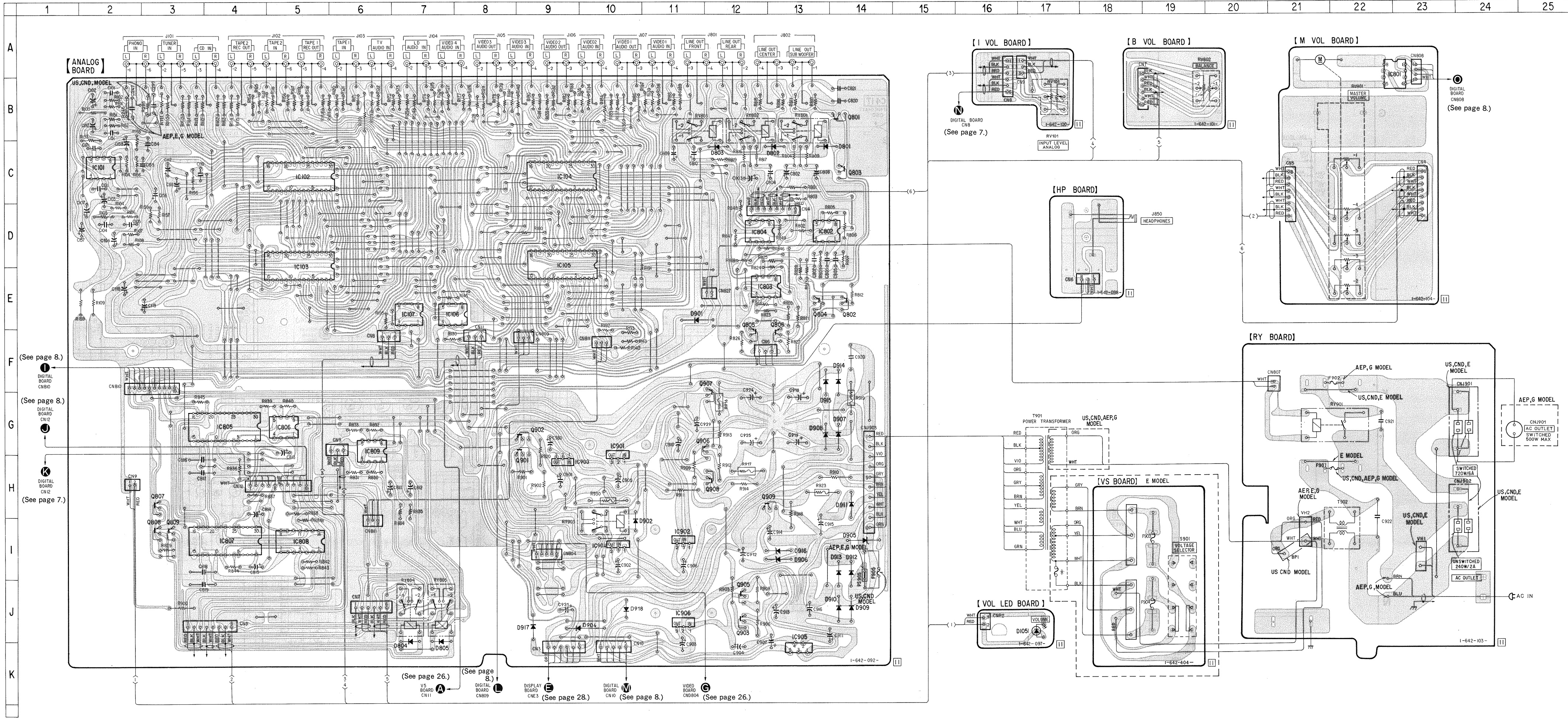

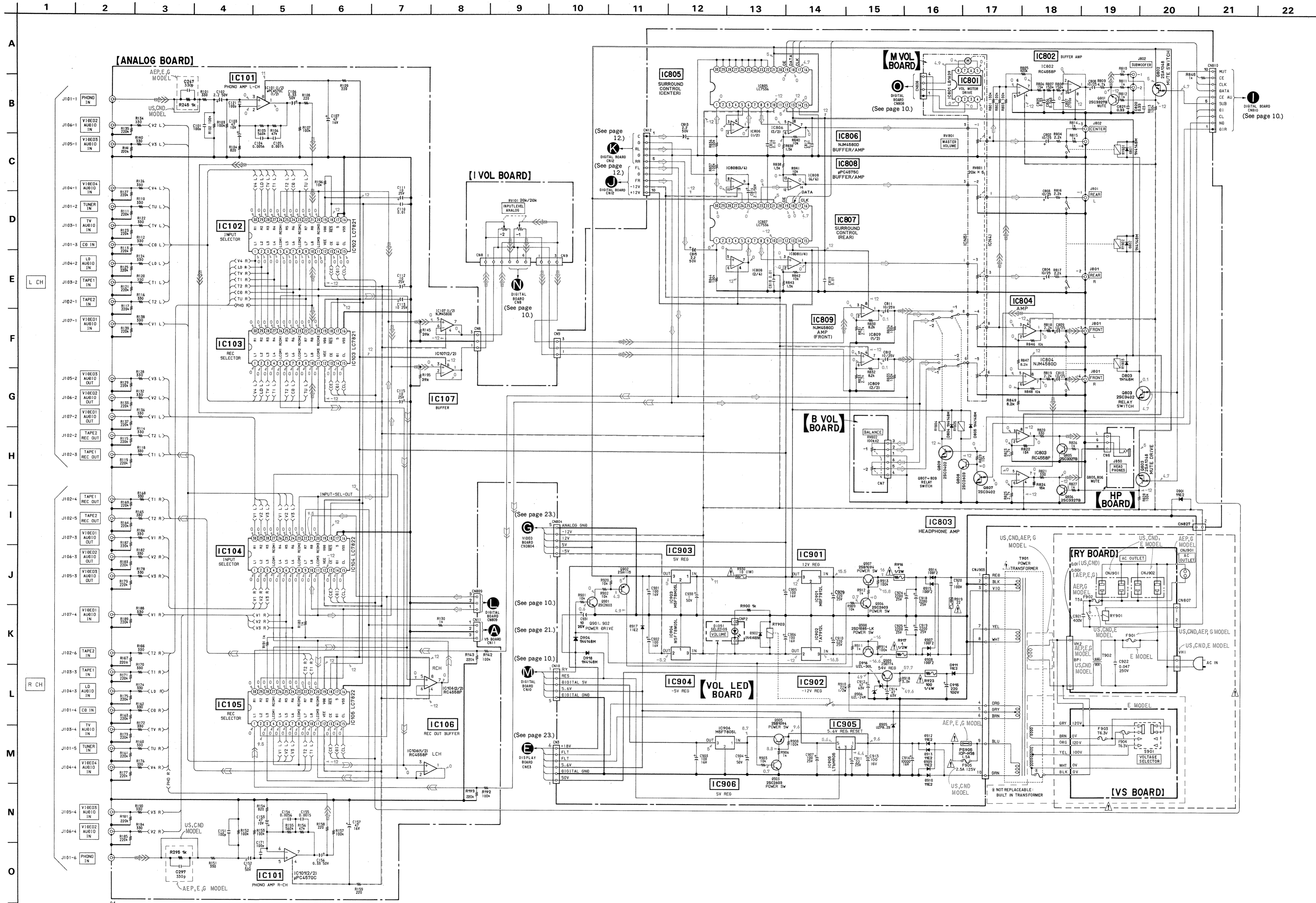

Note:

- All capacitors are in μF unless otherwise noted. $\text{pF} = \mu\text{F} \times 10^{-6}$.
- 50WV or less are not indicated except for electrolytics and tantalums.
- All resistors are in Ω and $1/4\text{W}$ or less unless otherwise specified.
- ---/--- : fusible resistor.

Note: The components identified by mark Δ or dotted line with mark Δ are critical for safety. Replace only with part number specified.

Note: Les composants identifiés par une marque Δ sont critiques pour la sécurité. Ne les remplacer que par une pièce portant le numéro spécifié.

\ominus : B+ Line
 \ominus : B- Line
 Voltage is dc with respect to ground under no-signal conditions. no mark: PHONO
 Voltages are taken with a VOM (Input Impedance 10M Ω). Voltage variations may be noted due to normal production tolerances.
Signal path:
 \Rightarrow : analog signal
 \Rightarrow : REC
 \Rightarrow : PHONO
 CND : Canadian model
 G : Germany model

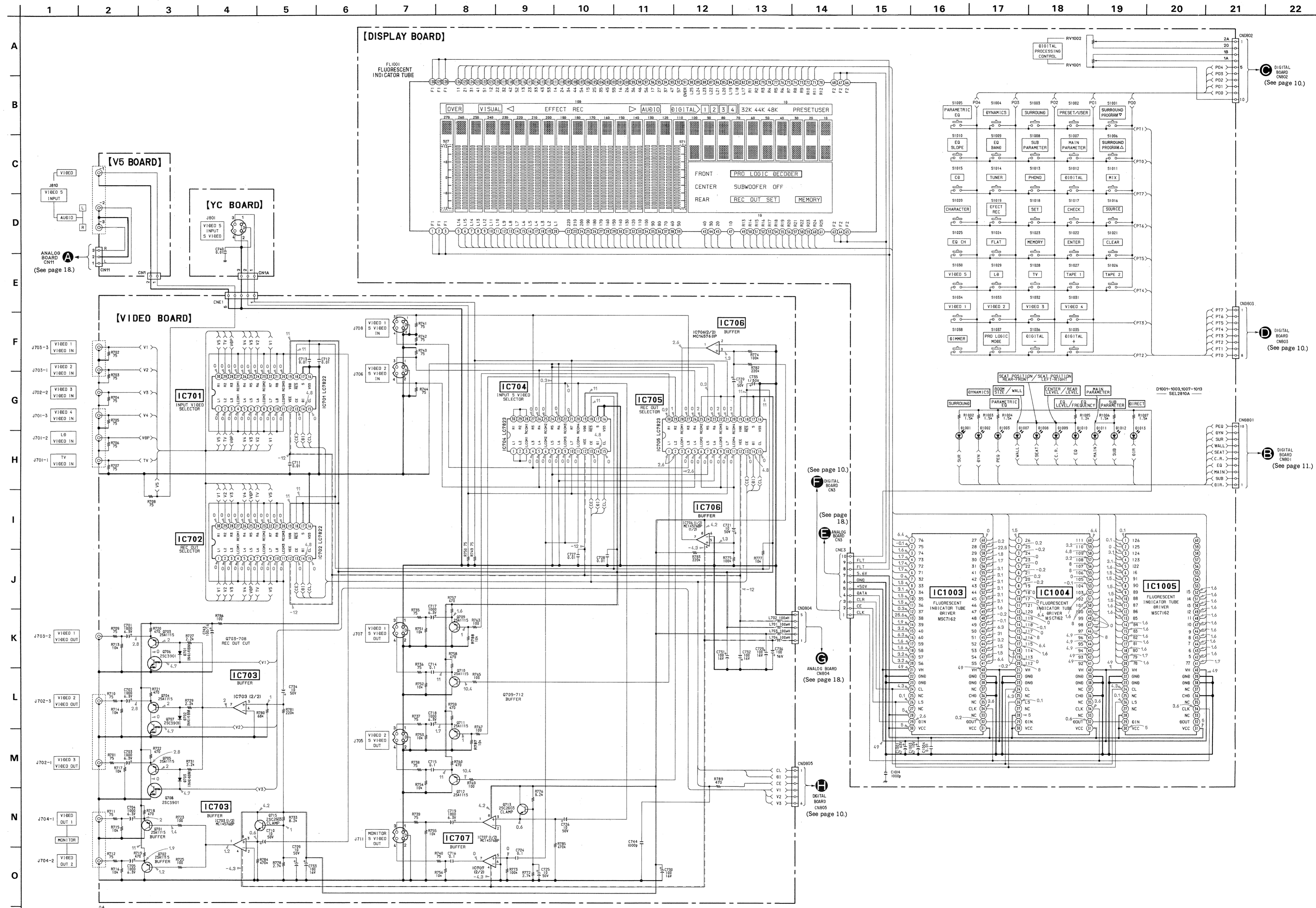

Note:

- All capacitors are in μF unless otherwise noted. pF: μF 50WV or less are not indicated except for electrolytics and tantalums.
- All resistors are in Ω and $\frac{1}{4}\text{W}$ or less unless otherwise specified.
- : B+ Line
- : B- Line
- Voltage is dc with respect to ground under no-signal conditions. no mark: PHONO
- Voltages are taken with a VOM (Input Impedance 10M Ω). Voltage variations may be noted due to normal production tolerances.

2-8. PRINTED WIRING BOARDS—VIDEO, DISPLAY SECTION— Refer to page 13 for Semiconductor Lead Layouts.

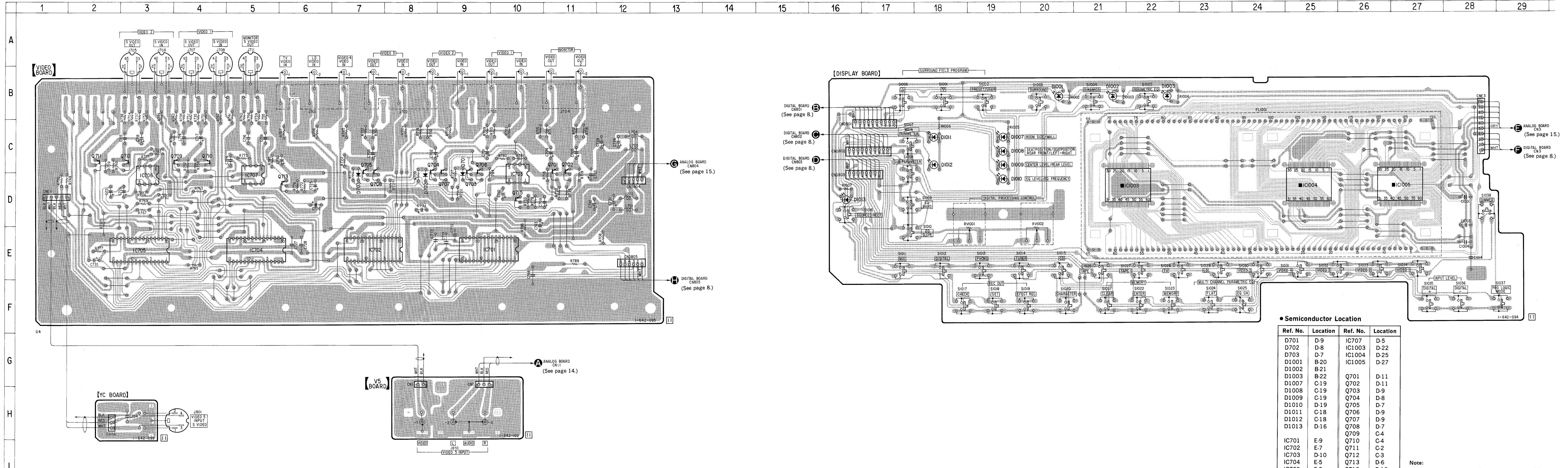

• Semiconductor Location

Ref. No.	Location	Ref. No.	Location
D701	D-9	IC707	D-5
D702	D-8	IC1003	D-22
D703	D-7	IC1004	D-25
D1001	B-20	IC1005	D-27
D1002	B-21		
D1003	B-22	Q701	D-11
D1007	C-19	Q702	D-11
D1008	C-19	Q703	D-9
D1009	C-19	Q704	D-8
D1010	D-19	Q705	D-7
D1011	C-18	Q706	D-9
D1012	C-18	Q707	D-9
D1013	D-16	Q708	D-7
		Q709	C-4
		Q710	C-4
IC701	E-9	Q711	C-2
IC702	E-7	Q712	C-3
IC703	D-10	Q713	D-6
IC704	E-5	Q715	D-10
IC705	E-3		
IC706	D-3		

Note:
 ○ — parts extracted from the component side.
 ● — parts mounted on the conductor side.

• IC Block Diagrams

IC102, 103 LC7821

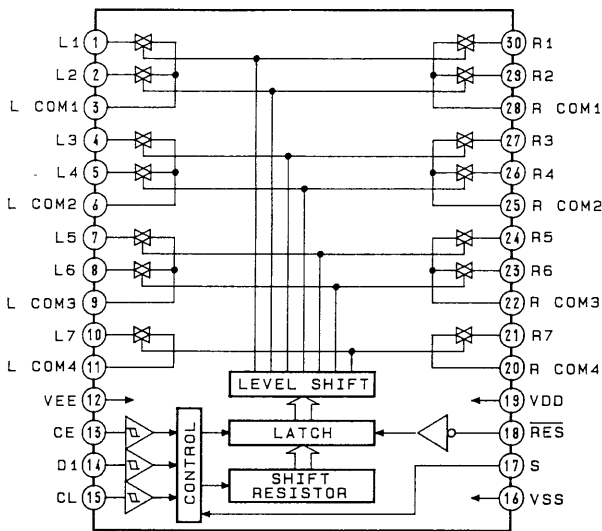

IC104, 105, 701, 702 LC7822

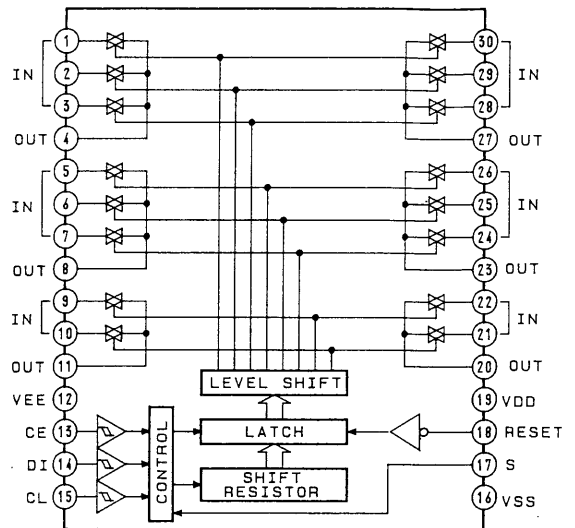

IC306, 307 SN74HC153N

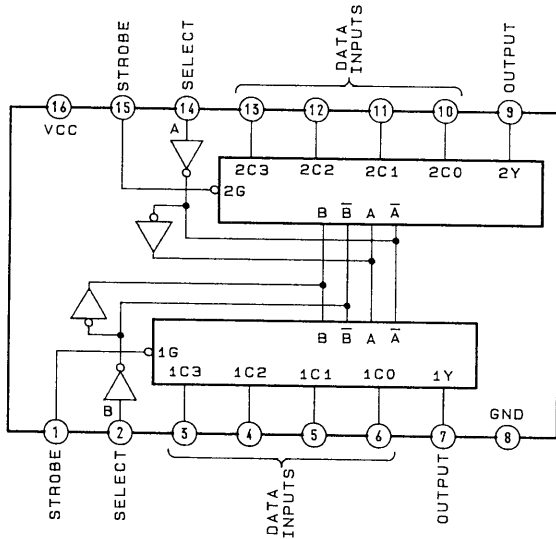

IC311 SN74HC393N

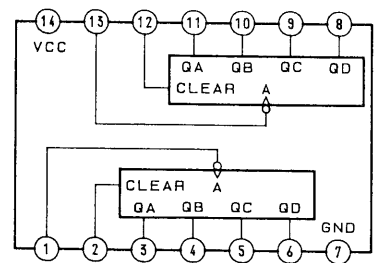

IC310 TC5081AP

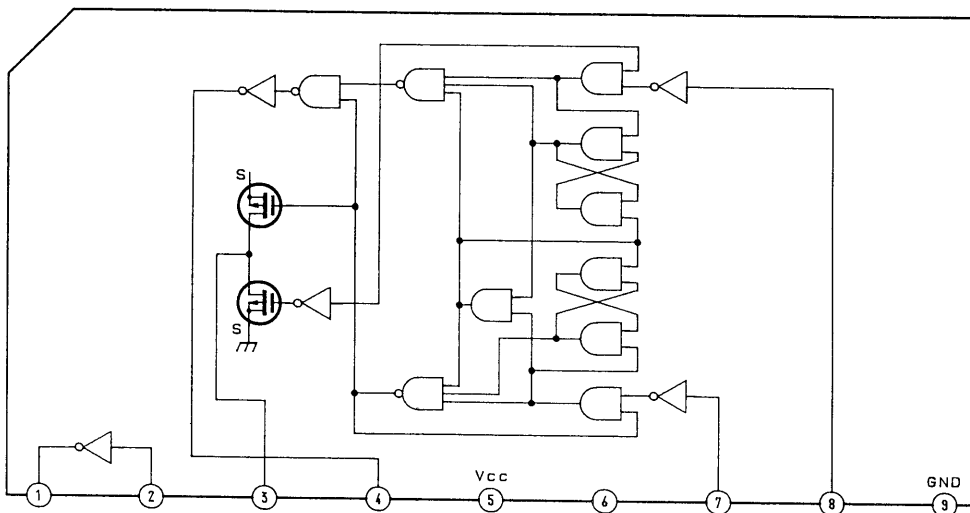

IC314 YM3623B

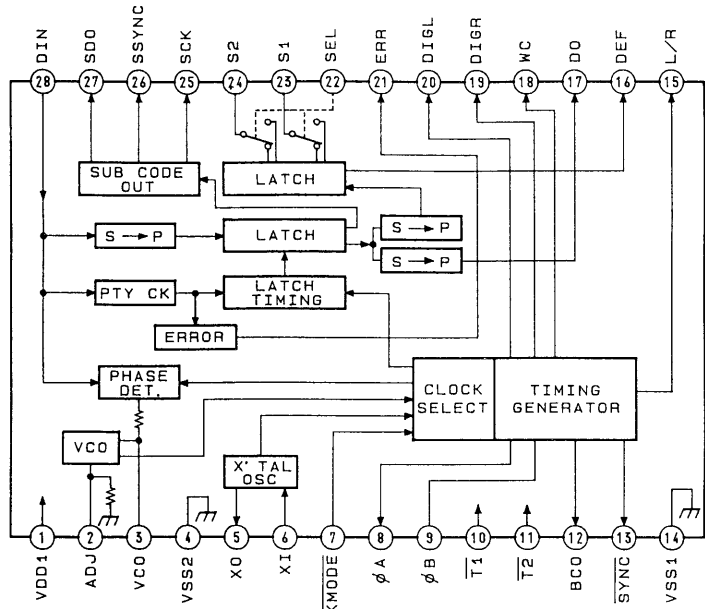

IC401 AK5328

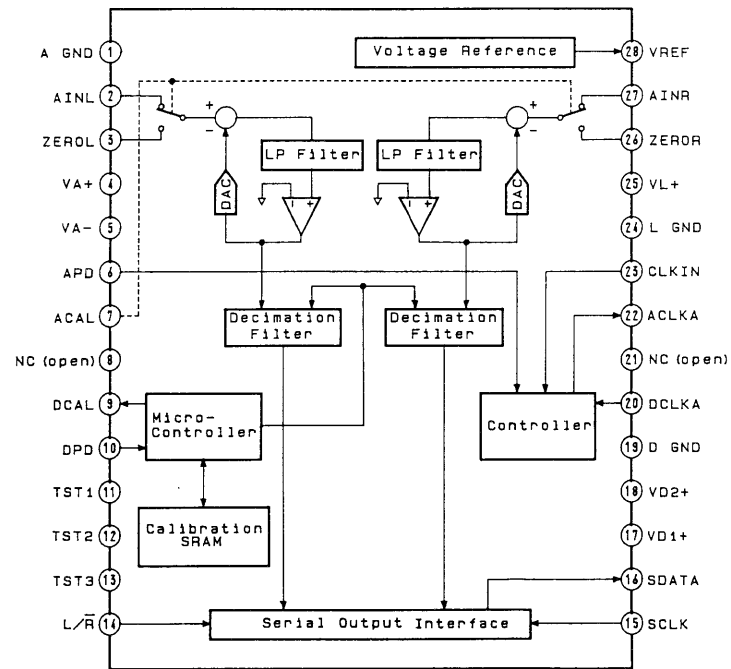

IC410, 412 CXD2701Q

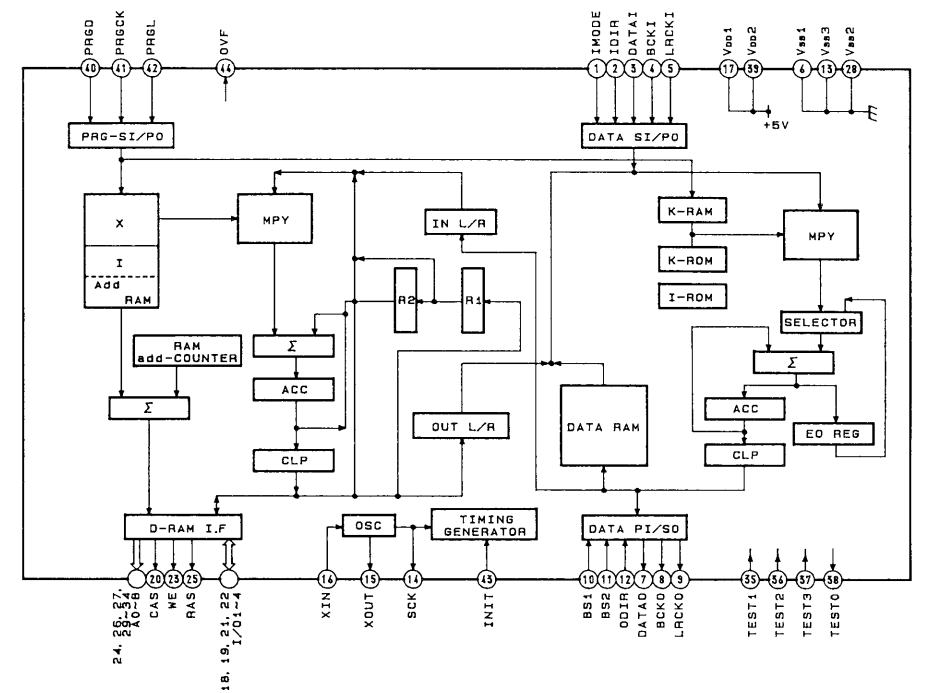

IC411, 413 MSM514256

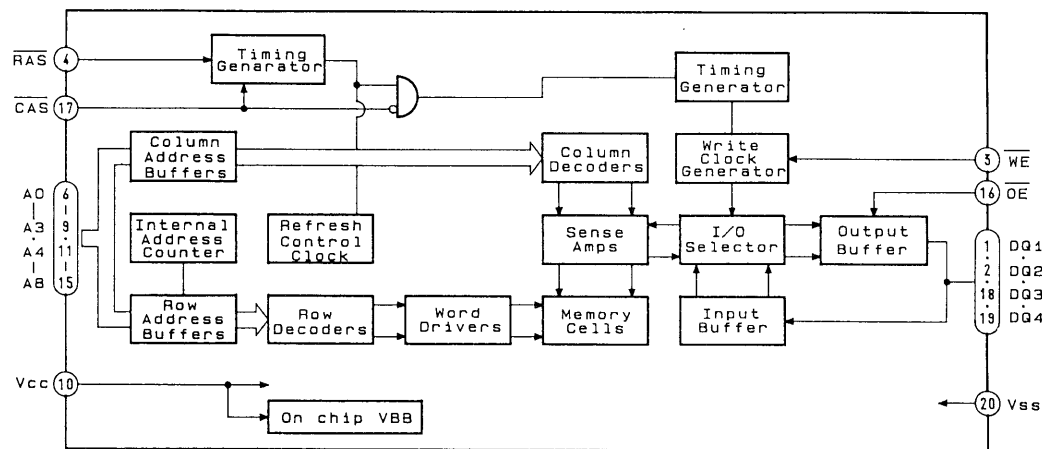

IC414, 415, 416 CXD2560M

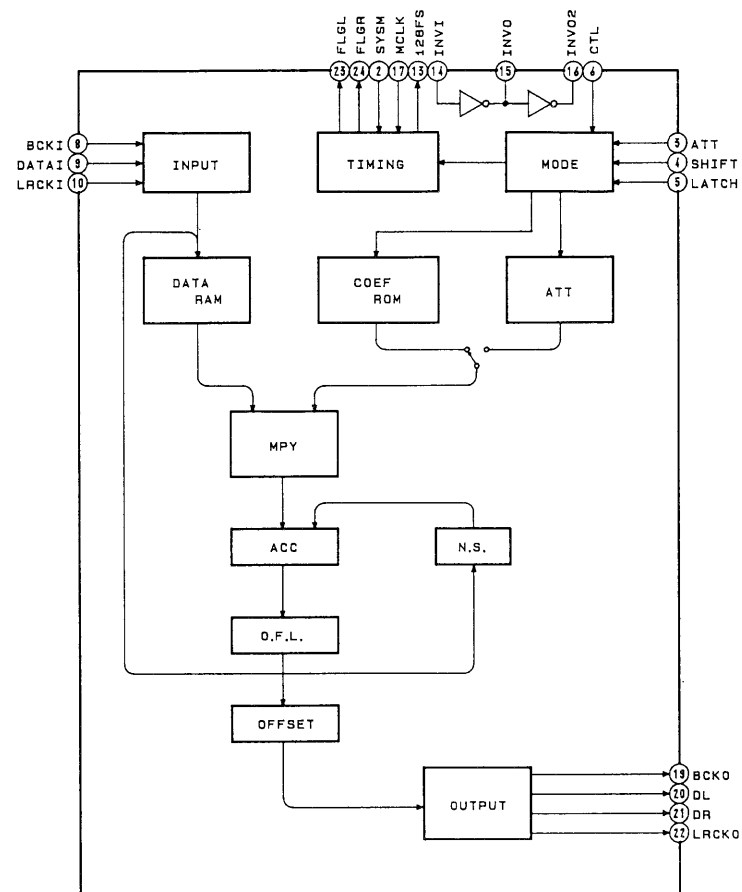

IC418 LC7883K

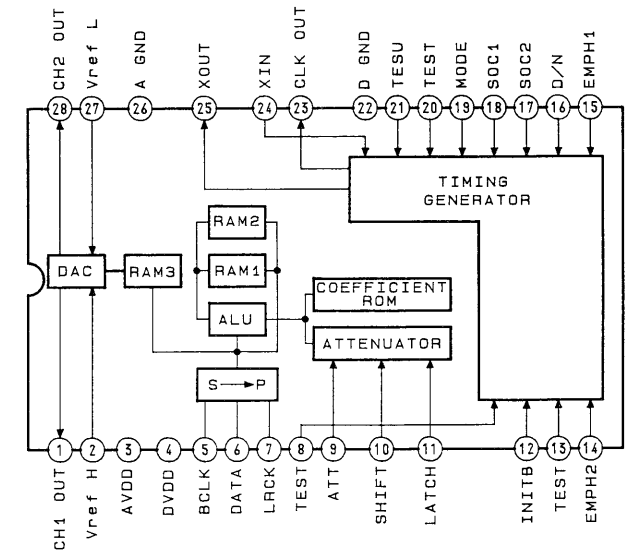

IC704, 705 LC7823

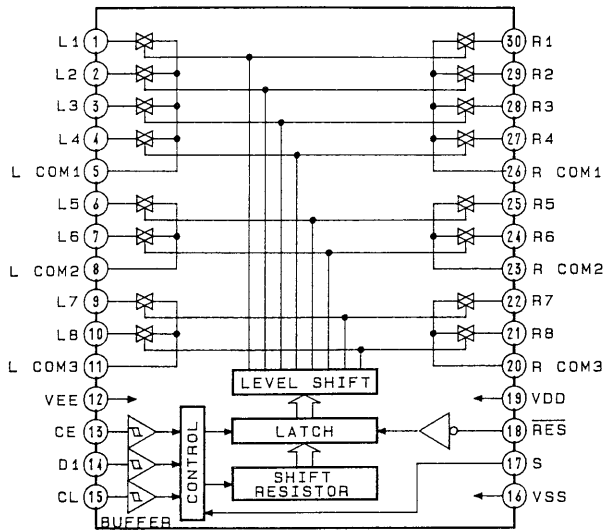

IC801 LB1639

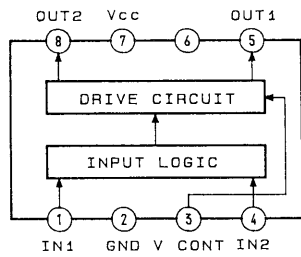

IC805, 807 LC7536

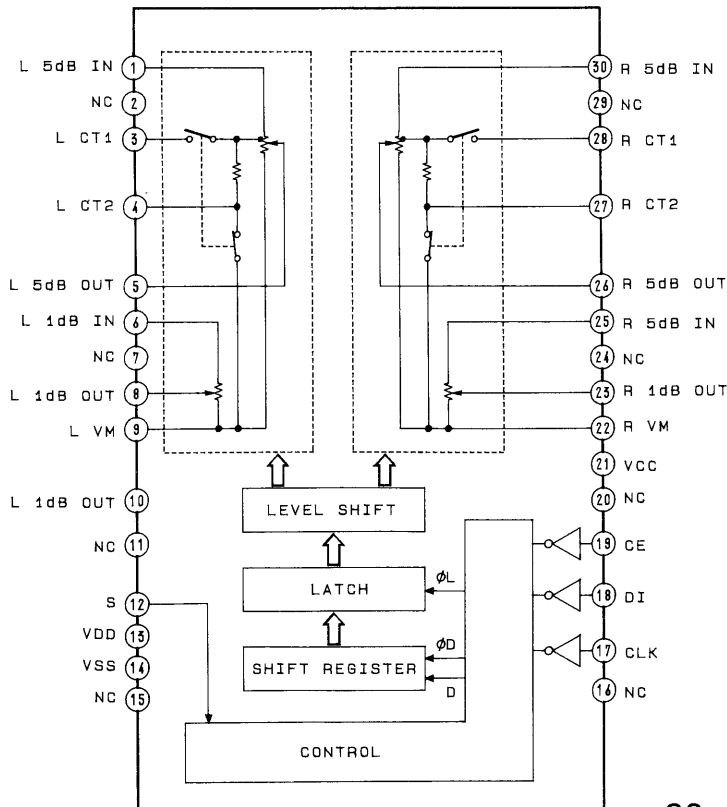

IC905 L78MR05

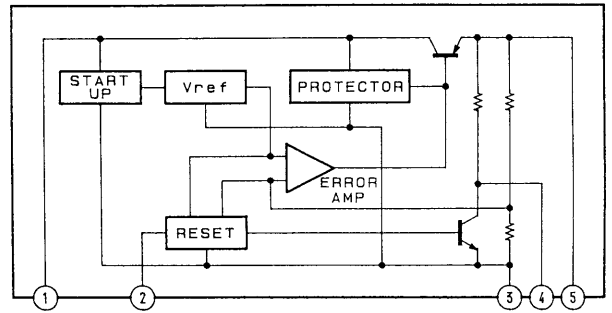

IC1003, 1004, 1005 MSC7162

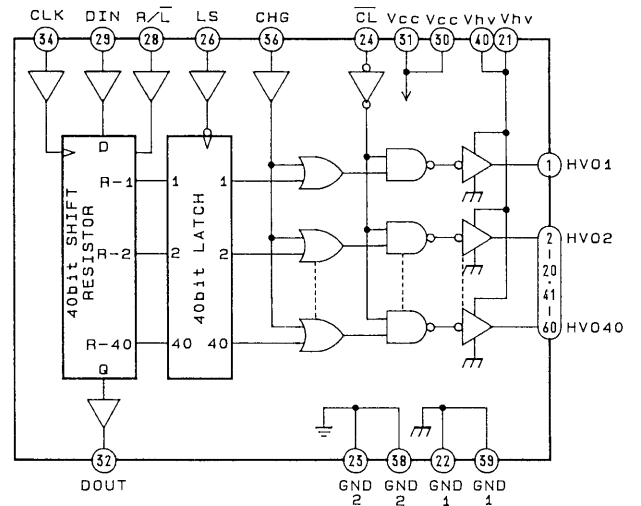

SECTION 3 EXPLODED VIEWS

NOTE:

- The mechanical parts with no reference number in the exploded views are not supplied.
- Items marked "*" are not stocked since they are seldom required for routine service. Some delay should be anticipated when ordering these items.

- -XX and -X mean standardized parts, so they may have some difference from the original one.

- Color Indication of Appearance Parts
Example :
KNOB, BALANCE (WHITE)... (RED)
 ↑ ↑
 Parts Color Cabinet's Color

- Hardware (# mark) list is given in the last of this parts list.

The components identified by mark \triangle or dotted line with mark \triangle are critical for safety. Replace only with part number specified.

Les composants identifiés par une marque \triangle sont critiques pour la sécurité. Ne les remplacer que par une pièce portant le numéro spécifié.

· G : Germany model

3-1. CHASSIS, MAIN BOARD SECTION

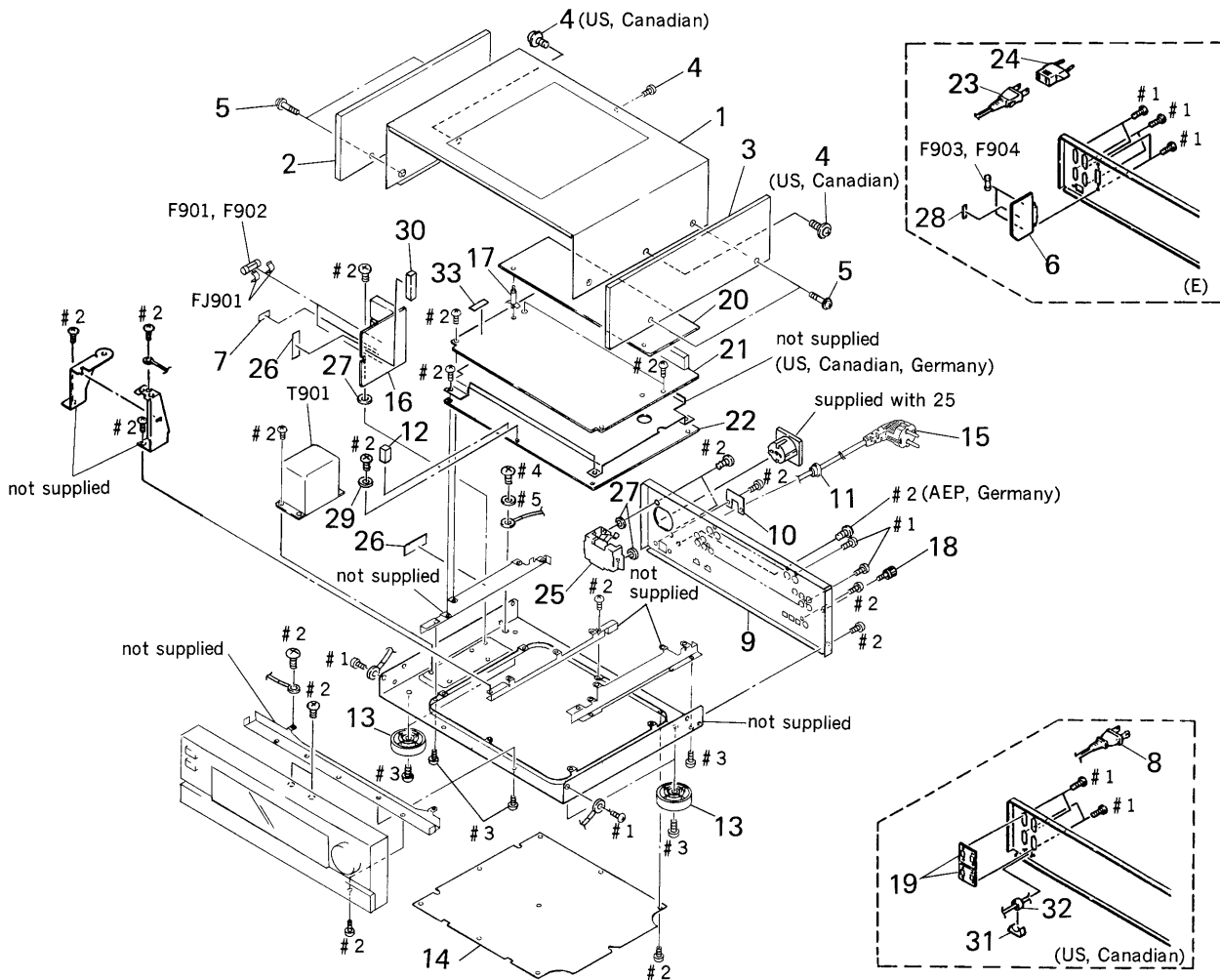

Ref. No.	Part No.	Description	Remark
* 1	4-949-489-01	CASE (US, Canadian)	
* 1	4-949-489-11	CASE (AEP, G, E)	
2	X-4933-401-1	PANEL (LEFT) ASSY, SIDE (EXCEPT G)	
2	X-4933-407-1	PANEL (LEFT) ASSY, SIDE (G)	
3	X-4933-402-1	PANEL (RIGHT) ASSY, SIDE (EXCEPT G)	
3	X-4933-408-1	PANEL (RIGHT) ASSY, SIDE (G)	
4	3-704-366-31	SCREW (CASE) (M3X6)	
5	4-933-446-01	SCREW (SIDE PANEL)	
* 6	1-642-404-11	V. S. BOARD (E)	
7	3-701-946-30	LABEL (1A125V), FUSE (US, Canadian)	
* 7	4-949-520-07	LABEL (B) (T.L), FUSE RATING (AEP, G)	
△8	1-559-479-11	CORD, POWER (US, Canadian)	
* 9	4-933-413-52	PANEL, BACK (US, Canadian)	
* 9	4-933-413-71	PANEL, BACK (AEP, G)	
* 9	4-933-413-82	PANEL, BACK (E)	
* 10	4-923-873-01	BRACKET, CORD STOPPER	
11	2-352-626-01	BUSHING, CORD (AEP, G)	
11	4-916-783-01	BUSHING, CORD (US, Canadian, E)	
12	4-926-318-01	CUSHION (A)	
13	X-3304-944-1	FOOT ASSY	
* 14	4-908-036-11	PLATE, BOTTOM	
△15	1-551-238-00	CORD, POWER 3 CORE (AEP, G)	
* 16	1-642-103-11	Rÿ BOARD	
* 17	4-924-098-81	HOLDER, PC BOARD	
* 18	4-941-033-01	SCREW, FIXED, FEEDER	

Ref. No.	Part No.	Description	Remark
* 19	4-931-038-01	SPACER (2 GANG) (US, Canadian)	
* 20	A-4347-548-A	VIDEO BOARD, COMPLETE	
* 21	A-4345-684-A	ANALOG BOARD, COMPLETE (US, Canadian)	
* 21	A-4347-684-A	ANALOG BOARD, COMPLETE (AEP, G, E)	
* 22	A-4347-549-A	DIGITAL BOARD, COMPLETE	
△23	1-559-297-31	CODE, POWER (E)	
24	1-569-007-11	ADAPTER, CONVERSION 2P (E)	
△25	1-526-988-11	OUTLET, AC (CEE) (AEP, G)	
* 26	3-703-044-26	LABEL, CAUTION (US, Canadian)	
27	4-309-378-00	WASHER (AEP, G)	
28	3-701-947-09	LABEL (T630MA), FUSE (E)	
29	4-945-833-11	WASHER (DIA. 14) (AEP, G)	
30	4-953-740-01	CUSHION (AEP, G)	
31	1-543-619-41	CORE, RING (US, Canadian, G)	
32	1-543-824-11	CORE, TROIDAL (US, Canadian, G)	
* 33	3-701-946-24	LABEL (2.5A125V), FUSE (US, Canadian)	
△F901	1-532-613-XX	FUSE, TIME-LAG (250V 0.2A) (AEP, G)	
△F901	1-532-740-11	FUSE, GLASS TUBE (US, Canadian)	
△F902	1-532-299-00	FUSE, TIME-LAG (T5A) (AEP, G)	
△F903	1-532-284-00	FUSE, TIME-LAG (T6.3A) (E)	
△F904	1-532-284-00	FUSE, TIME-LAG (T6.3A) (E)	
△FJ901	1-533-189-11	HOLDER, FUSE	
△T901	1-449-835-11	TRANSFORMER, POWER (US, Canadian)	
△T901	1-449-881-11	TRANSFORMER, POWER (AEP, G)	
△T901	1-449-883-11	TRANSFORMER, POWER (E)	

3-2. FRONT PANEL SECTION

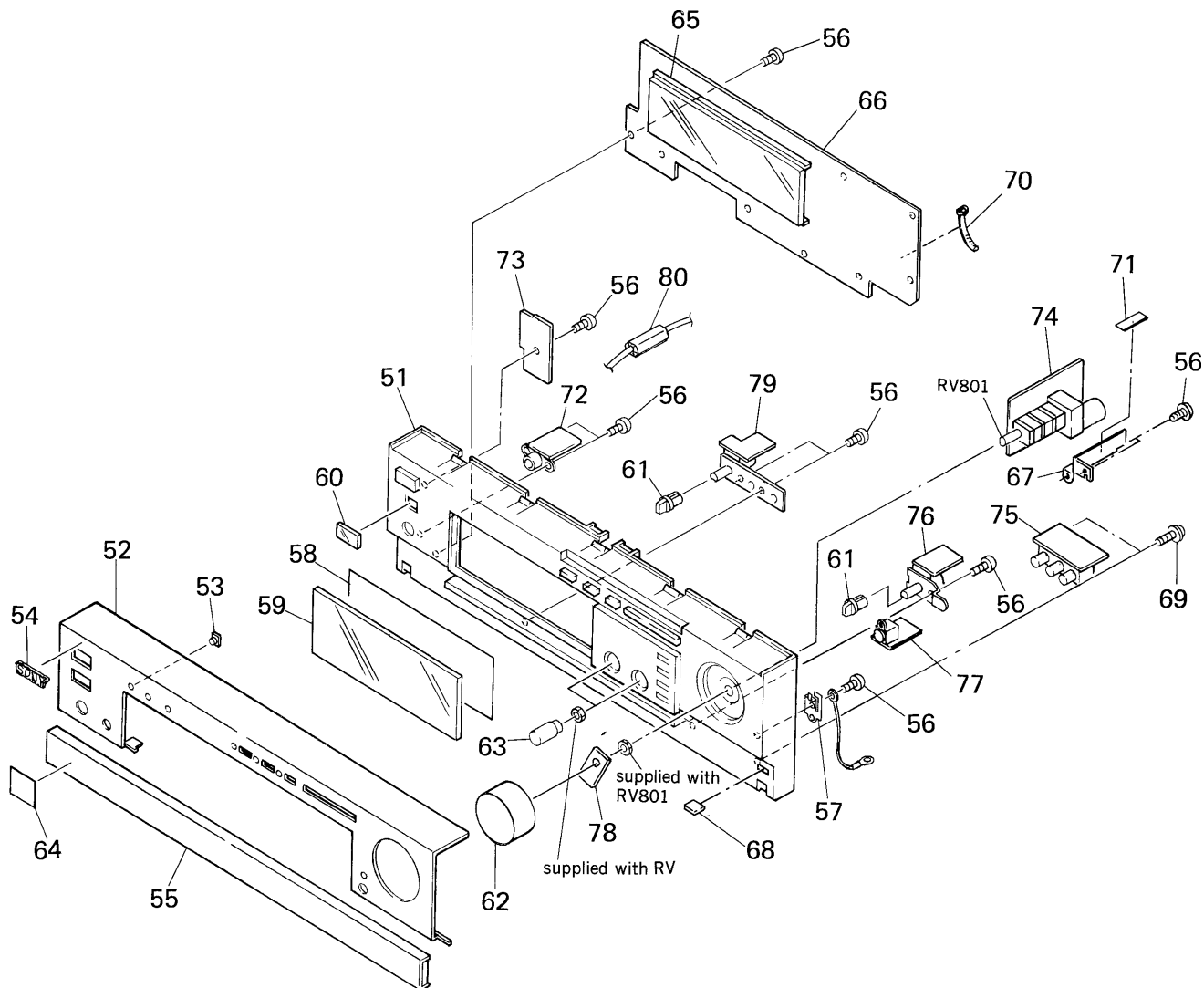

Ref. No.	Part No.	Description	Remark
51	X-4942-246-1	PANEL (B) ASSY (AEP, E)	
51	X-4942-833-1	PANEL (B) ASSY (US, Canadian, G)	
52	4-949-486-01	PANEL, FRONT	
53	4-884-612-11	INDICATOR, EJECT (US, Canadian, AEP, G)	
54	4-908-884-01	EMBLEM, SONY	
55	A-4325-248-A	LID ASSY (E)	
55	A-4325-576-A	LID ASSY (US, Canadian)	
55	A-4325-651-A	LID ASSY (AEP, G)	
56	4-951-620-01	SCREW (2. 6X8), +BVTP	
* 57	4-950-053-01	PLATE, GROUND	
58	4-933-401-01	FILTER (W)	
59	4-949-487-01	WINDOW, TRANSPARENT	
60	4-933-412-01	FILTER (R) (US, Canadian)	
60	4-933-412-11	FILTER (R) (AEP, G, E)	
61	4-921-921-01	KNOB (M)	
62	X-4942-104-1	KNOB (DIA. 55) ASSY	
63	4-949-519-01	KNOB (DIA. 13)	
* 64	3-703-713-41	STICKER, SONY SYMBOL (10) (US, Canadian, E)	

Ref. No.	Part No.	Description	Remark
* 65	4-933-419-01	HOLDER (FL)	
* 66	A-4345-695-A	DISPLAY BOARD, COMPLETE	
* 67	4-949-524-01	BRACKET (MV)	
68	1-452-419-21	MAGNET	
* 69	4-917-583-21	BRACKET, YOKE	
70	3-655-653-21	BAND (TAITON), BINDING	
71	4-952-135-01	SHEET, ADHESIVE	
* 72	1-642-098-11	H. P. BOARD	
* 73	1-642-096-11	SW BOARD	
* 74	1-642-104-11	M VOL BOARD	
* 75	1-642-102-11	V5 BOARD	
* 76	1-642-101-11	B VOL BOARD	
* 77	1-642-099-11	YC BOARD	
* 78	1-642-097-11	VOL LED BOARD	
* 79	1-642-100-11	I VOL BOARD	
80	1-543-786-11	CLAMP, SLEEVE FERRITE (US, Canadian, G)	
RV801	1-241-254-21	RES, VAR, CARBON 20KX5 (MASTER VOLUME)	

ANALOG

**SECTION 4
ELECTRICAL PARTS LIST**

NOTE:

- Due to standardization, replacements in the parts list may be different from the parts specified in the diagrams or the components used on the set.
- -XX and -X mean standardized parts, so they may have some difference from the original one.
- RESISTORS
All resistors are in ohms.
METAL: Metal-film resistor.
METAL OXIDE: Metal oxide-film resistor.
F: nonflammable

- Items marked "*" are not stocked since they are seldom required for routine service. Some delay should be anticipated when ordering these items.
- SEMICONDUCTORS
In each case, u: μ , for example:
uA ..: μ A. uPA ..: μ PA.
uPB ..: μ PB. uPC ..: μ PC. uPD ..: μ PD.
- CAPACITORS
uF: μ F
- COILS
uH: μ H

The components identified by mark Δ or dotted line with mark Δ are critical for safety. Replace only with part number specified.

Les composants identifiés par une marque Δ sont critiques pour la sécurité. Ne les remplacer que par une pièce portant le numéro spécifié.

When indicating parts by reference number, please include the board.

- G : Germany model

Ref. No.	Part No.	Description	Remark
*	A-4347-684-A	ANALOG BOARD, COMPLETE	(AEP, G, E)
*	A-4345-684-A	ANALOG BOARD, COMPLETE	(US, Canadian)

< CAPACITOR >			
C101	1-110-335-11	MYLAR 100PF	5% 50V
C102	1-123-381-00	ELECT 2.2uF	20% 100V
C103	1-126-022-11	ELECT 47uF	20% 10V
C104	1-130-480-00	MYLAR 0.0056uF	5% 50V
C105	1-130-473-00	MYLAR 0.0015uF	5% 50V
C106	1-124-252-00	ELECT 0.33uF	20% 50V
C107	1-126-022-11	ELECT 47uF	20% 16V
C110	1-136-153-00	FILM 0.01uF	5% 50V
C111	1-126-059-11	ELECT 10uF	20% 25V
C112	1-126-059-11	ELECT 10uF	20% 25V
C113	1-126-059-11	ELECT 10uF	20% 25V
C115	1-126-059-11	ELECT 10uF	20% 25V
C121	1-110-335-11	MYLAR 100PF	5% 50V
C151	1-110-335-11	MYLAR 100PF	5% 50V
C152	1-123-381-00	ELECT 2.2uF	20% 100V
C153	1-126-022-11	ELECT 47uF	20% 10V
C154	1-130-480-00	MYLAR 0.0056uF	5% 50V
C155	1-130-473-00	MYLAR 0.0015uF	5% 50V
C156	1-124-252-00	ELECT 0.33uF	20% 50V
C157	1-126-022-11	ELECT 47uF	20% 16V
C171	1-110-335-11	MYLAR 100PF	5% 50V
C247	1-162-288-31	CERAMIC 330PF	10% 50V
		(AEP, G, E)	
C297	1-162-288-31	CERAMIC 330PF	10% 50V
		(AEP, G, E)	
C802	1-126-059-11	ELECT 10uF	20% 25V
C803	1-126-059-11	ELECT 10uF	20% 25V
C804	1-126-059-11	ELECT 10uF	20% 25V
C805	1-136-171-00	FILM 0.33uF	5% 50V
C806	1-136-163-00	FILM 0.068uF	5% 50V
C807	1-130-476-00	MYLAR 0.0027uF	5% 50V
C808	1-126-059-11	ELECT 10uF	20% 25V
C809	1-126-059-11	ELECT 10uF	20% 25V
C810	1-126-059-11	ELECT 10uF	20% 25V
C811	1-126-059-11	ELECT 10uF	20% 25V

Ref. No.	Part No.	Description	Remark
C812	1-126-059-11	ELECT 10uF	20% 25V
C813	1-123-381-00	ELECT 2.2uF	20% 100V
C814	1-123-381-00	ELECT 2.2uF	20% 100V
C815	1-123-381-00	ELECT 2.2uF	20% 100V
C816	1-162-306-11	CERAMIC 0.01uF	20% 16V
C817	1-162-306-11	CERAMIC 0.01uF	20% 16V
C818	1-162-306-11	CERAMIC 0.01uF	20% 16V
C819	1-162-306-11	CERAMIC 0.01uF	20% 16V
C820	1-136-171-00	FILM 0.33uF	5% 50V
C821	1-136-171-00	FILM 0.33uF	5% 50V
C901	1-126-023-11	ELECT 100uF	20% 16V
C902	1-126-023-11	ELECT 100uF	20% 16V
C903	1-126-023-11	ELECT 100uF	20% 16V
C904	1-126-044-11	ELECT 1uF	20% 50V
C905	1-126-023-11	ELECT 100uF	20% 16V
C906	1-126-023-11	ELECT 100uF	20% 16V
C907	1-126-023-11	ELECT 100uF	20% 25V
C910	1-126-024-11	ELECT 220uF	20% 25V
C911	1-126-049-11	ELECT 22uF	20% 25V
C912	1-124-918-11	ELECT 47uF	20% 63V
C913	1-126-023-11	ELECT 100uF	20% 16V
C914	1-124-918-11	ELECT 47uF	20% 63V
C915	1-124-628-11	ELECT 220uF	20% 100V
C916	1-126-939-11	ELECT 10000uF	20% 16V
C918	1-126-028-81	ELECT 2200uF	20% 25V
C919	1-126-028-81	ELECT 2200uF	20% 25V
C920	1-130-789-00	FILM 1uF	5% 100V
C924	1-126-028-81	ELECT 2200uF	20% 25V
C925	1-126-028-81	ELECT 2200uF	20% 25V
C929	1-126-024-11	ELECT 220uF	20% 25V
C930	1-126-044-11	ELECT 1uF	20% 50V
C931	1-126-059-11	ELECT 10uF	20% 25V
< CONNECTOR >			
* CN3	1-564-509-11	PLUG, CONNECTOR 6P	
* CN4	1-564-511-11	PLUG, CONNECTOR 8P	
* CN5	1-564-511-11	PLUG, CONNECTOR 8P	
* CN7	1-564-509-11	PLUG, CONNECTOR 6P	
* CN8	1-564-506-11	PLUG, CONNECTOR 3P	

ANALOG

Ref. No.	Part No.	Description	Remark
* CN9	1-564-506-11	PLUG, CONNECTOR 3P	
* CN10	1-564-508-11	PLUG, CONNECTOR 5P	
* CN11	1-564-506-11	PLUG, CONNECTOR 3P	
* CN12	1-564-513-11	PLUG, CONNECTOR 10P	
* CN809	1-564-337-00	PIN, CONNECTOR 3P	
* CN810	1-564-666-11	PIN, CONNECTOR 10P	
* CNJ903	1-506-599-11	PIN, CONNECTOR (B10P-VH) 10P	
* CNP2	1-564-704-11	PIN, CONNECTOR (SMALL TYPE) 2P	
< DIODE >			
D801	8-719-987-63	DIODE 1N4148M	
D802	8-719-987-63	DIODE 1N4148M	
D803	8-719-987-63	DIODE 1N4148M	
D804	8-719-987-63	DIODE 1N4148M	
D805	8-719-987-63	DIODE 1N4148M	
D901	8-719-200-82	DIODE 11ES2	
D902	8-719-987-63	DIODE 1N4148M	
D904	8-719-987-63	DIODE 1N4148M	
D905	8-719-014-98	DIODE UZP-8. 2B	
D906	8-719-934-13	DIODE HZS24-1L	
D907	8-719-911-55	DIODE U05G	
D908	8-719-911-55	DIODE U05G	
D909	8-719-200-82	DIODE 11ES2	
D910	8-719-200-82	DIODE 11ES2	
D911	8-719-200-82	DIODE 11ES2	
D912	8-719-200-82	DIODE 11ES2	
D913	8-719-200-82	DIODE 11ES2	
D914	8-719-911-55	DIODE U05G	
D915	8-719-911-55	DIODE U05G	
D916	8-719-934-22	DIODE HZS30-2L	
D917	8-719-200-82	DIODE 11ES2	
D918	8-719-987-63	DIODE 1N4148M	
< FUSE >			
△F905	1-532-780-21	FUSE, MICRO 2.5A 125V (US, Canadian)	
< IC >			
IC101	8-759-106-41	IC uPC4570C	
IC102	8-759-805-13	IC LC7821	
IC103	8-759-805-13	IC LC7821	
IC104	8-759-805-14	IC LC7822	
IC105	8-759-805-14	IC LC7822	
IC106	8-759-945-58	IC RC4558P	
IC107	8-759-710-59	IC NJM4580D-D (US, Canadian)	
IC107	8-759-711-35	IC NJM4580D (AEP, G, E)	
IC802	8-759-945-58	IC RC4558P	
IC803	8-759-945-58	IC RC4558P	
IC804	8-759-710-59	IC NJM4580D-D (US, Canadian)	

Ref. No.	Part No.	Description	Remark
IC804	8-759-711-35	IC NJM4580D (AEP, G, E)	
IC805	8-759-824-12	IC LC7536	
IC806	8-759-710-59	IC NJM4580D-D (US, Canadian)	
IC806	8-759-711-35	IC NJM4580D (AEP, G, E)	
IC807	8-759-824-12	IC LC7536	
IC808	8-759-113-18	IC uPC4574C	
IC809	8-759-710-59	IC NJM4580D-D (US, Canadian)	
IC809	8-759-711-35	IC NJM4580D (AEP, G, E)	
IC901	8-759-231-58	IC M5F7812L	
IC902	8-759-245-86	IC TA7912S	
IC903	8-759-604-35	IC M5F78M05	
IC904	8-759-982-52	IC RC79M05FA	
IC905	8-759-820-84	IC L78MR05	
IC906	8-759-231-53	IC M5F7805	
< JACK >			
* J101	1-691-260-21	JACK, PIN 6P (PHONO/TUNER/CD IN)	
* J102	1-691-260-21	JACK, PIN 6P (TAPE 2 IN, TAPE 1/TAPE 2 REC OUT)	
* J103	1-573-520-31	JACK, PIN 4P (TV AUDIO/TAPE 1 IN)	
* J104	1-573-520-31	JACK, PIN 4P (VIDEO 4 AUDIO/LD AUDIO IN)	
* J105	1-573-520-31	JACK, PIN 4P (VIDEO 3 AUDIO IN/OUT)	
* J106	1-573-520-31	JACK, PIN 4P (VIDEO 2 AUDIO IN/OUT)	
* J107	1-573-520-31	JACK, PIN 4P (VIDEO 1 AUDIO IN/OUT)	
* J801	1-573-520-31	JACK, PIN 4P (FRONT, REAR)	
* J802	1-573-520-21	JACK, PIN 4P (SUB WOOFER, CENTER)	
< IC LINK >			
△PS905	1-532-675-00	LINK, IC 1.5A (AEP, G, E)	
< TRANSISTOR >			
Q801	8-729-203-49	TRANSISTOR 2SC3327-B	
Q802	8-729-900-61	TRANSISTOR DTA114ES	
Q803	8-729-900-80	TRANSISTOR DTC114ES	
Q804	8-729-900-61	TRANSISTOR DTA114ES	
Q805	8-729-203-49	TRANSISTOR 2SC3327-B	
Q806	8-729-203-49	TRANSISTOR 2SC3327-B	
Q807	8-729-900-80	TRANSISTOR DTC114ES	
Q808	8-729-620-05	TRANSISTOR 2SC2603-EF	
Q809	8-729-900-80	TRANSISTOR DTC114ES	
Q901	8-729-620-05	TRANSISTOR 2SC2603-EF	
Q902	8-729-119-76	TRANSISTOR 2SA1175-HFE	
Q903	8-729-620-05	TRANSISTOR 2SC2603-EF	
Q905	8-729-141-83	TRANSISTOR 2SB1094-LK	
Q906	8-729-620-05	TRANSISTOR 2SC2603-EF	
Q907	8-729-141-83	TRANSISTOR 2SB1094-LK	
Q908	8-729-141-89	TRANSISTOR 2SD1585-K	
Q909	8-729-140-96	TRANSISTOR 2SD774-34	

The components identified by mark △ or dotted line with mark △ are critical for safety. Replace only with part number specified.

Les composants identifiés par une marque △ sont critiques pour la sécurité. Ne les remplacer que par une pièce portant le numéro spécifié.

ANALOG

Ref. No.	Part No.	Description	Remark			Ref. No.	Part No.	Description	Remark		
< RESISTOR >											
R101	1-259-416-11	CARBON	330	5%	1/6W	R155	1-259-494-11	CARBON	560K	5%	1/6W
R102	1-259-476-11	CARBON	100K	5%	1/6W	R156	1-259-468-11	CARBON	47K	5%	1/6W
R103	1-259-476-11	CARBON	100K	5%	1/6W	R157	1-259-476-11	CARBON	100K	5%	1/6W
R104	1-259-426-11	CARBON	820	5%	1/6W	R158	1-259-412-11	CARBON	220	5%	1/6W
R105	1-259-494-11	CARBON	560K	5%	1/6W	R159	1-247-704-11	CARBON	220	5%	1/4W
R106	1-259-468-11	CARBON	47K	5%	1/6W	R160	1-259-416-11	CARBON	330	5%	1/6W
R107	1-259-476-11	CARBON	100K	5%	1/6W	R161	1-259-484-11	CARBON	220K	5%	1/6W
R108	1-259-412-11	CARBON	220	5%	1/6W	R162	1-259-416-11	CARBON	330	5%	1/6W
R109	1-247-704-11	CARBON	220	5%	1/4W	R163	1-259-484-11	CARBON	220K	5%	1/6W
R110	1-259-416-11	CARBON	330	5%	1/6W	R164	1-259-484-11	CARBON	220K	5%	1/6W
R111	1-259-484-11	CARBON	220K	5%	1/6W	R165	1-259-416-11	CARBON	330	5%	1/6W
R112	1-259-416-11	CARBON	330	5%	1/6W	R166	1-259-416-11	CARBON	330	5%	1/6W
R113	1-259-484-11	CARBON	220K	5%	1/6W	R167	1-259-484-11	CARBON	220K	5%	1/6W
R114	1-259-416-11	CARBON	330	5%	1/6W	R168	1-259-416-11	CARBON	330	5%	1/6W
R115	1-259-484-11	CARBON	220K	5%	1/6W	R169	1-259-484-11	CARBON	220K	5%	1/6W
R116	1-259-416-11	CARBON	330	5%	1/6W	R170	1-259-416-11	CARBON	330	5%	1/6W
R117	1-259-484-11	CARBON	220K	5%	1/6W	R171	1-259-484-11	CARBON	220K	5%	1/6W
R118	1-259-416-11	CARBON	330	5%	1/6W	R172	1-259-416-11	CARBON	330	5%	1/6W
R119	1-259-484-11	CARBON	220K	5%	1/6W	R173	1-259-484-11	CARBON	220K	5%	1/6W
R120	1-259-416-11	CARBON	330	5%	1/6W	R174	1-259-416-11	CARBON	330	5%	1/6W
R121	1-259-484-11	CARBON	220K	5%	1/6W	R175	1-259-484-11	CARBON	220K	5%	1/6W
R122	1-259-416-11	CARBON	330	5%	1/6W	R176	1-259-416-11	CARBON	330	5%	1/6W
R123	1-259-484-11	CARBON	220K	5%	1/6W	R177	1-259-484-11	CARBON	220K	5%	1/6W
R124	1-259-416-11	CARBON	330	5%	1/6W	R178	1-259-416-11	CARBON	330	5%	1/6W
R125	1-259-484-11	CARBON	220K	5%	1/6W	R179	1-259-484-11	CARBON	220K	5%	1/6W
R126	1-259-416-11	CARBON	330	5%	1/6W	R180	1-259-428-11	CARBON	1K	5%	1/6W
R127	1-259-484-11	CARBON	220K	5%	1/6W	R181	1-259-484-11	CARBON	220K	5%	1/6W
R128	1-259-416-11	CARBON	330	5%	1/6W	R182	1-259-416-11	CARBON	330	5%	1/6W
R129	1-259-484-11	CARBON	220K	5%	1/6W	R183	1-259-484-11	CARBON	220K	5%	1/6W
R130	1-259-428-11	CARBON	1K	5%	1/6W	R184	1-259-416-11	CARBON	330	5%	1/6W
R132	1-259-416-11	CARBON	330	5%	1/6W	R185	1-259-484-11	CARBON	220K	5%	1/6W
R133	1-259-484-11	CARBON	220K	5%	1/6W	R186	1-259-416-11	CARBON	330	5%	1/6W
R134	1-259-416-11	CARBON	330	5%	1/6W	R187	1-259-484-11	CARBON	220K	5%	1/6W
R135	1-259-484-11	CARBON	220K	5%	1/6W	R188	1-259-416-11	CARBON	330	5%	1/6W
R136	1-259-416-11	CARBON	330	5%	1/6W	R189	1-259-484-11	CARBON	220K	5%	1/6W
R137	1-259-484-11	CARBON	220K	5%	1/6W	R190	1-259-416-11	CARBON	330	5%	1/6W
R138	1-259-416-11	CARBON	330	5%	1/6W	R191	1-259-428-11	CARBON	1K	5%	1/6W
R139	1-259-484-11	CARBON	220K	5%	1/6W	R192	1-259-476-11	CARBON	100K	5%	1/6W
R140	1-259-416-11	CARBON	330	5%	1/6W	R193	1-259-484-11	CARBON	220K	5%	1/6W
R141	1-259-484-11	CARBON	220K	5%	1/6W	R195	1-259-466-11	CARBON	39K	5%	1/6W
R142	1-259-476-11	CARBON	100K	5%	1/6W	R196	1-259-452-11	CARBON	10K	5%	1/6W
R143	1-259-484-11	CARBON	220K	5%	1/6W	R245	1-259-428-11	CARBON (AEP, G, E)	1K	5%	1/6W
R145	1-259-466-11	CARBON	39K	5%	1/6W	R295	1-259-428-11	CARBON (AEP, G, E)	1K	5%	1/6W
R151	1-259-416-11	CARBON	330	5%	1/6W	R801	1-259-476-11	CARBON	100K	5%	1/6W
R152	1-259-476-11	CARBON	100K	5%	1/6W	R802	1-259-476-11	CARBON	100K	5%	1/6W
R153	1-259-476-11	CARBON	100K	5%	1/6W	R803	1-259-476-11	CARBON	100K	5%	1/6W
R154	1-259-426-11	CARBON	820	5%	1/6W	R804	1-259-436-11	CARBON	2.2K	5%	1/6W

ANALOG

B VOL

DIGITAL

Ref. No.	Part No.	Description	Remark
R805	1-259-498-11	CARBON	820K 5% 1/6W
R806	1-259-456-11	CARBON	15K 5% 1/6W
R807	1-259-480-11	CARBON	150K 5% 1/6W
R808	1-259-480-11	CARBON	150K 5% 1/6W
R809	1-259-444-11	CARBON	4.7K 5% 1/6W
R810	1-259-428-11	CARBON	1K 5% 1/6W
R811	1-259-428-11	CARBON	1K 5% 1/6W
R812	1-259-428-11	CARBON	1K 5% 1/6W
R813	1-259-476-11	CARBON	100K 5% 1/6W
R814	1-259-428-11	CARBON	1K 5% 1/6W
R815	1-259-428-11	CARBON	1K 5% 1/6W
R816	1-259-436-11	CARBON	2.2K 5% 1/6W
R817	1-259-436-11	CARBON	2.2K 5% 1/6W
R818	1-259-436-11	CARBON	2.2K 5% 1/6W
R819	1-259-436-11	CARBON	2.2K 5% 1/6W
R820	1-259-416-11	CARBON	330 5% 1/6W
R821	1-259-416-11	CARBON	330 5% 1/6W
R822	1-259-456-11	CARBON	15K 5% 1/6W
R823	1-259-438-11	CARBON	2.7K 5% 1/6W
R824	1-259-456-11	CARBON	15K 5% 1/6W
R825	1-259-438-11	CARBON	2.7K 5% 1/6W
R826	1-259-428-11	CARBON	1K 5% 1/6W
R827	1-259-428-11	CARBON	1K 5% 1/6W
R828	1-259-476-11	CARBON	100K 5% 1/6W
R829	1-259-452-11	CARBON	10K 5% 1/6W
R830	1-259-450-11	CARBON	8.2K 5% 1/6W
R831	1-259-438-11	CARBON	2.7K 5% 1/6W
R832	1-259-450-11	CARBON	8.2K 5% 1/6W
R833	1-259-438-11	CARBON	2.7K 5% 1/6W
R834	1-259-476-11	CARBON	100K 5% 1/6W
R835	1-259-476-11	CARBON	100K 5% 1/6W
R836	1-259-476-11	CARBON	100K 5% 1/6W
R837	1-259-476-11	CARBON	100K 5% 1/6W
R838	1-259-432-11	CARBON	1.5K 5% 1/6W
R839	1-259-432-11	CARBON	1.5K 5% 1/6W
R840	1-259-452-11	CARBON	10K 5% 1/6W
R841	1-259-452-11	CARBON	10K 5% 1/6W
R842	1-259-452-11	CARBON	10K 5% 1/6W
R843	1-259-432-11	CARBON	1.5K 5% 1/6W
R844	1-259-476-11	CARBON	100K 5% 1/6W
R845	1-259-428-11	CARBON	1K 5% 1/6W
R846	1-259-452-11	CARBON	10K 5% 1/6W
R847	1-259-450-11	CARBON	8.2K 5% 1/6W
R848	1-259-452-11	CARBON	10K 5% 1/6W
R849	1-259-450-11	CARBON	8.2K 5% 1/6W
R900	1-259-428-11	CARBON	1K 5% 1/6W
R901	1-259-452-11	CARBON	10K 5% 1/6W
R902	1-259-452-11	CARBON	10K 5% 1/6W
R903	1-259-452-11	CARBON	10K 5% 1/6W

Ref. No.	Part No.	Description	Remark
R906	1-259-428-11	CARBON	1K 5% 1/6W
R908	1-259-476-11	CARBON	100K 5% 1/6W
R909	1-259-452-11	CARBON	10K 5% 1/6W
R910	1-249-489-11	CARBON	22K 5% 1/2W
R911	1-259-428-11	CARBON	1K 5% 1/6W
R912	1-259-428-11	CARBON	1K 5% 1/6W
R913	1-259-476-11	CARBON	100K 5% 1/6W
R914	1-259-476-11	CARBON	100K 5% 1/6W
△R916	1-212-934-00	FUSIBLE	1 5% 1/2W F
△R917	1-212-934-00	FUSIBLE	1 5% 1/2W F
R918	1-259-440-11	CARBON	3.3K 5% 1/6W
△R919	1-212-865-00	FUSIBLE	22 5% 1/4W F
R920	1-259-452-11	CARBON	10K 5% 1/6W
△R923	1-212-881-11	FUSIBLE	100 5% 1/4W F
△R930	1-217-481-00	FUSIBLE	10 5% 1W F
< RELAY >			
RY801	1-515-726-11	RELAY	
RY802	1-515-726-11	RELAY	
RY803	1-515-726-11	RELAY	
RY804	1-515-726-11	RELAY	
RY805	1-515-726-11	RELAY	
RY903	1-515-726-11	RELAY	

* 1-642-101-11	B VOL BOARD		

< CONNECTOR >			
* CN4	1-564-511-11	PLUG, CONNECTOR 8P	
< VARIABLE RESISTOR >			
RV802	1-237-886-11	RES, VAR, CARBON 100K/100K (BALANCE)	

* A-4347-549-A	DIGITAL BOARD, COMPLETE		

< CAPACITOR >			
C301	1-126-022-11	ELECT	47uF 20% 10V
C302	1-164-159-11	CERAMIC	0.1uF 50V
C303	1-164-159-11	CERAMIC	0.1uF 50V
C304	1-164-159-11	CERAMIC	0.1uF 50V
C305	1-126-022-11	ELECT	47uF 20% 10V
C306	1-164-159-11	CERAMIC	0.1uF 50V
C307	1-126-059-11	ELECT	10uF 20% 50V
C308	1-126-022-11	ELECT	47uF 20% 10V
C309	1-164-159-11	CERAMIC	0.1uF 50V
C310	1-126-022-11	ELECT	47uF 20% 10V

<p>The components identified by mark △ or dotted line with mark △ are critical for safety. Replace only with part number specified.</p>	<p>Les composants identifiés par une marque △ sont critiques pour la sécurité. Ne les remplacer que par une pièce portant le numéro spécifié.</p>
---	---

DIGITAL

Ref. No.	Part No.	Description	Remark			Ref. No.	Part No.	Description	Remark		
C311	1-162-306-11	CERAMIC	0.01uF	20%	16V	C426	1-164-159-11	CERAMIC	0.1uF		50V
C312	1-162-306-11	CERAMIC	0.01uF	20%	16V	C427	1-162-294-31	CERAMIC	0.001uF	10%	50V
C313	1-162-207-31	CERAMIC	22PF	5%	50V	C432	1-164-159-11	CERAMIC	0.1uF		50V
C314	1-164-159-11	CERAMIC	0.1uF		50V	C433	1-126-022-11	ELECT	47uF	20%	10V
C320	1-136-165-00	FILM	0.1uF	5%	50V	C434	1-126-022-11	ELECT	47uF	20%	10V
C321	1-124-611-00	ELECT	1uF	20%	50V	C436	1-126-049-11	ELECT	22uF	20%	25V
C322	1-124-995-11	ELECT	220uF	20%	10V	C439	1-130-475-00	MYLAR	0.0022uF	5%	50V
C323	1-164-159-11	CERAMIC	0.1uF		50V	C440	1-164-159-11	CERAMIC	0.1uF		50V
C325	1-164-159-11	CERAMIC	0.1uF		50V	C442	1-126-059-11	ELECT	10uF	20%	50V
C326	1-162-306-11	CERAMIC	0.01uF	20%	16V	C443	1-162-211-31	CERAMIC	33PF	5%	50V
C328	1-162-199-31	CERAMIC	10PF	5%	50V	C444	1-162-306-11	CERAMIC	0.01uF	20%	16V
C329	1-126-049-11	ELECT	22uF	20%	25V	C445	1-162-211-31	CERAMIC	33PF	5%	50V
C330	1-162-211-31	CERAMIC	33PF	5%	50V	C448	1-164-159-11	CERAMIC	0.1uF		50V
C331	1-162-199-31	CERAMIC	10PF	5%	50V	C449	1-162-294-31	CERAMIC	0.001uF	10%	50V
C332	1-164-159-11	CERAMIC	0.1uF		50V	C451	1-130-483-00	MYLAR	0.01uF	5%	50V
C333	1-124-995-11	ELECT	220uF	20%	10V	C453	1-126-059-11	ELECT	10uF	20%	50V
C334	1-162-306-11	CERAMIC	0.01uF	20%	16V	C454	1-126-049-11	ELECT	22uF	20%	25V
C335	1-162-294-31	CERAMIC	0.001uF	10%	50V	C455	1-130-483-00	MYLAR	0.01uF	5%	50V
C337	1-164-159-11	CERAMIC	0.1uF		50V	C457	1-164-159-11	CERAMIC	0.1uF		50V
C339	1-164-159-11	CERAMIC	0.1uF		50V	C458	1-126-022-11	ELECT	47uF	20%	25V
C341	1-126-022-11	ELECT	47uF	20%	10V	C459	1-164-159-11	CERAMIC	0.1uF		50V
C342	1-164-159-11	CERAMIC	0.1uF		50V	C460	1-162-294-31	CERAMIC	0.001uF	10%	50V
C343	1-130-481-00	MYLAR	0.0068uF	5%	50V	C461	1-126-044-11	ELECT	1uF	20%	50V
C344	1-162-207-31	CERAMIC	22PF	5%	50V	C462	1-162-294-31	CERAMIC	0.001uF	10%	50V
C345	1-162-207-31	CERAMIC	22PF	5%	50V	C463	1-162-294-31	CERAMIC	0.001uF	10%	50V
C346	1-164-159-11	CERAMIC	0.1uF		50V	C464	1-162-294-31	CERAMIC	0.001uF	10%	50V
C350	1-164-159-11	CERAMIC	0.1uF		50V	C466	1-162-294-31	CERAMIC	0.001uF	10%	50V
C378	1-162-199-31	CERAMIC	10PF	5%	50V	C467	1-162-294-31	CERAMIC	0.001uF	10%	50V
C401	1-130-483-00	MYLAR	0.01uF	5%	50V	C469	1-162-294-31	CERAMIC	0.001uF	10%	50V
C403	1-126-059-11	ELECT	10uF	20%	50V	C470	1-162-294-31	CERAMIC	0.001uF	10%	50V
C404	1-126-049-11	ELECT	22uF	20%	25V	C481	1-126-059-11	ELECT	10uF	20%	50V
C405	1-130-483-00	MYLAR	0.01uF	5%	50V	C482	1-126-059-11	ELECT	10uF	20%	50V
C407	1-164-159-11	CERAMIC	0.1uF		50V	C489	1-130-475-00	MYLAR	0.0022uF	5%	50V
C408	1-126-022-11	ELECT	47uF	20%	25V	C492	1-126-059-11	ELECT	10uF	20%	50V
C409	1-164-159-11	CERAMIC	0.1uF		50V	C493	1-124-994-11	ELECT	100uF	20%	10V
C410	1-126-022-11	ELECT	47uF	20%	25V	C499	1-164-159-11	CERAMIC	0.1uF		50V
C411	1-164-159-11	CERAMIC	0.1uF		50V	C501	1-110-339-11	MYLAR	220PF	5%	50V
C412	1-126-049-11	ELECT	22uF	20%	25V	C502	1-110-339-11	MYLAR	220PF	5%	50V
C413	1-164-159-11	CERAMIC	0.1uF		50V	C503	1-110-339-11	MYLAR	220PF	5%	50V
C414	1-126-049-11	ELECT	22uF	20%	25V	C504	1-110-339-11	MYLAR	220PF	5%	50V
C415	1-136-165-00	FILM	0.1uF	5%	50V	C505	1-110-335-11	MYLAR	100PF	5%	50V
C417	1-164-159-11	CERAMIC	0.1uF		50V	C506	1-110-335-11	MYLAR	100PF	5%	50V
C418	1-164-159-11	CERAMIC	0.1uF		50V	C507	1-130-479-00	MYLAR	0.0047uF	5%	50V
C419	1-124-994-11	ELECT	100uF	20%	10V	C508	1-130-472-00	MYLAR	0.0012uF	5%	50V
C420	1-164-159-11	CERAMIC	0.1uF		50V	C510	1-126-022-11	ELECT	47uF	20%	25V
C422	1-124-994-11	ELECT	100uF	20%	10V	C511	1-126-022-11	ELECT	47uF	20%	25V
C423	1-164-159-11	CERAMIC	0.1uF		50V	C512	1-126-022-11	ELECT	47uF	20%	25V
C424	1-164-159-11	CERAMIC	0.1uF		50V	C513	1-126-022-11	ELECT	47uF	20%	25V
C425	1-164-159-11	CERAMIC	0.1uF		50V	C515	1-126-059-11	ELECT	10uF	20%	50V

DIGITAL

Ref. No.	Part No.	Description	Remark	Ref. No.	Part No.	Description	Remark
		< DIODE >					
D301	8-719-903-27	DIODE 1SS168		IC416	8-752-342-65	IC CXD2560M	
D304	8-719-918-45	DIODE KV1310		IC417	8-759-917-18	IC SN74HCU04N	
D305	8-719-903-27	DIODE 1SS168		IC418	8-759-040-59	IC LC7883K	
D306	8-719-987-63	DIODE 1N4148M		IC419	8-752-343-18	IC CXD2704Q	
D307	8-719-987-63	DIODE 1N4148M		IC420	8-759-000-55	IC MC14078BCP	
D308	8-719-987-63	DIODE 1N4148M		IC421	8-759-945-58	IC RC4558P	
D403	8-719-200-82	DIODE 11ES2		IC501	8-759-044-10	IC CXD2562Q	
D501	8-719-987-63	DIODE 1N4148M		IC502	8-759-900-72	IC NE5532P	
D1014	8-719-987-63	DIODE 1N4148M		IC503	8-759-711-35	IC NJM4580D	
D1015	8-719-987-63	DIODE 1N4148M		IC504	8-759-604-35	IC M5F78M05	
D1016	8-719-987-63	DIODE 1N4148M		IC552	8-759-900-72	IC NE5532P	
D1018	8-719-987-63	DIODE 1N4148M		IC553	8-759-711-35	IC NJM4580D	
D1019	8-719-987-63	DIODE 1N4148M		IC601	8-759-044-10	IC CXD2562Q	
D1020	8-719-987-63	DIODE 1N4148M		IC602	8-759-900-72	IC NE5532P	
D1021	8-719-987-63	DIODE 1N4148M		IC603	8-759-711-35	IC NJM4580D	
D1022	8-719-987-63	DIODE 1N4148M		IC651	8-759-044-10	IC CXD2562Q	
D1023	8-719-022-21	DIODE 1T22A		IC652	8-759-900-72	IC NE5532P	
D1024	8-719-987-63	DIODE 1N4148M		IC653	8-759-711-35	IC NJM4580D	
D1025	8-719-987-63	DIODE 1N4148M		IC673	8-759-711-35	IC NJM4580D	
		< IC >		IC762	8-759-900-72	IC NE5532P	
IC301	8-759-977-72	IC GP-1F31R (OPTICAL 2 IN)		IC1001	8-759-080-78	IC HD6435368RA09F	
IC302	8-759-977-72	IC GP-1F31R (OPTICAL 1 IN)		IC1002	8-759-503-96	IC MSM59371RS	
IC304	8-759-977-71	IC GP-1F31T (OPTICAL 3 REC OUT)		IC1006	8-759-984-03	IC LM339N	
IC305	8-759-917-18	IC SN74HCU04N				< JACK >	
IC306	8-759-921-17	IC SN74HC153AN		J301	1-568-750-21	JACK, PIN (1P SHIELD TYPE) (COAXIAL IN)	
IC307	8-759-921-17	IC SN74HC153AN				< COIL >	
IC309	8-759-916-12	IC TC74HC00P		L301	1-410-324-11	INDUCTOR 4.7uH	
IC310	8-759-250-81	IC TC5081AP		L302	1-410-324-11	INDUCTOR 4.7uH	
IC311	8-759-917-11	IC SN74HC393N		L303	1-410-324-11	INDUCTOR 4.7uH	
IC312	8-759-917-18	IC SN74HCU04N		L304	1-410-324-11	INDUCTOR 4.7uH	
IC313	8-759-077-89	IC NJM78L08A-T3		L305	1-410-324-11	INDUCTOR 4.7uH	
IC314	8-759-973-98	IC YM3623B		L306	1-410-314-11	INDUCTOR 0.47uH	
IC315	8-759-916-12	IC TC74HC00P		L312	1-426-850-11	COIL (RF)	
IC316	8-759-916-12	IC TC74HC00P		L313	1-426-850-11	COIL (RF)	
IC401	8-759-502-91	IC AK5328-VP		L314	1-410-324-11	INDUCTOR 4.7uH	
IC402	8-759-711-35	IC NJM4580D		L315	1-410-324-11	INDUCTOR 4.7uH	
IC404	8-759-604-35	IC M5F78M05		L316	1-410-324-11	INDUCTOR 4.7uH	
IC405	8-759-982-52	IC RC79M05FA		L317	1-410-324-11	INDUCTOR 4.7uH	
IC406	8-741-717-01	IC SBX1717-01		L318	1-410-324-11	INDUCTOR 4.7uH	
IC410	8-752-341-99	IC CXD2701Q		L401	1-410-324-11	INDUCTOR 4.7uH	
IC411	8-759-506-48	IC MSM514256A-80RS-B		L402	1-410-324-11	INDUCTOR 4.7uH	
IC412	8-752-341-99	IC CXD2701Q		L403	1-410-324-11	INDUCTOR 4.7uH	
IC413	8-759-506-48	IC MSM514256A-80RS-B		L404	1-410-324-11	INDUCTOR 4.7uH	
IC414	8-752-342-65	IC CXD2560M		L406	1-410-324-11	INDUCTOR 4.7uH	
IC415	8-752-342-65	IC CXD2560M		L407	1-410-324-11	INDUCTOR 4.7uH	
				L408	1-410-324-11	INDUCTOR 4.7uH	

Ref. No.	Part No.	Description	Remark	Ref. No.	Part No.	Description	Remark
L409	1-410-324-11	INDUCTOR	4. 7uH	R321	1-259-440-11	CARBON	3. 3K 5% 1/6W
L411	1-410-324-11	INDUCTOR	4. 7uH	R322	1-259-428-11	CARBON	1K 5% 1/6W
L412	1-410-324-11	INDUCTOR	4. 7uH	R323	1-259-428-11	CARBON	1K 5% 1/6W
L413	1-410-324-11	INDUCTOR	4. 7uH	R324	1-259-452-11	CARBON	10K 5% 1/6W
L415	1-410-324-11	INDUCTOR	4. 7uH	R325	1-259-476-11	CARBON	100K 5% 1/6W
L501	1-410-324-11	INDUCTOR	4. 7uH	R326	1-259-500-11	CARBON	1M 5% 1/6W
L601	1-410-324-11	INDUCTOR	4. 7uH	R327	1-259-452-11	CARBON	10K 5% 1/6W
L602	1-410-324-11	INDUCTOR	4. 7uH	R328	1-259-450-11	CARBON	8. 2K 5% 1/6W
* L603	1-410-858-11	INDUCTOR	0uH	R329	1-259-476-11	CARBON	100K 5% 1/6W
L1001	1-410-314-11	INDUCTOR	0. 47uH	R330	1-259-428-11	CARBON	1K 5% 1/6W
L1002	1-410-314-11	INDUCTOR	0. 47uH	R331	1-259-428-11	CARBON	1K 5% 1/6W
L1003	1-410-314-11	INDUCTOR	0. 47uH	R332	1-259-428-11	CARBON	1K 5% 1/6W
L1004	1-410-314-11	INDUCTOR	0. 47uH	R333	1-259-404-11	CARBON	100 5% 1/6W
L1005	1-410-314-11	INDUCTOR	0. 47uH	R334	1-259-428-11	CARBON	1K 5% 1/6W
L1006	1-410-521-11	INDUCTOR	100uH	R335	1-259-500-11	CARBON	1M 5% 1/6W
< TRANSISTOR >				R336	1-259-500-11	CARBON	1M 5% 1/6W
Q301	8-729-900-80	TRANSISTOR	DTC114ES	R337	1-259-401-11	CARBON	75 5% 1/6W
Q303	8-729-200-56	TRANSISTOR	2SK241-GR	R338	1-259-452-11	CARBON	10K 5% 1/6W
Q304	8-729-200-56	TRANSISTOR	2SK241-GR	R339	1-249-782-11	CARBON	150 5% 1/6W
Q305	8-729-900-61	TRANSISTOR	DTA114ES	R340	1-259-404-11	CARBON	100 5% 1/6W
Q1001	8-729-900-80	TRANSISTOR	DTC114ES	R341	1-259-500-11	CARBON	1M 5% 1/6W
Q1002	8-729-900-80	TRANSISTOR	DTC114ES	R342	1-259-452-11	CARBON	10K 5% 1/6W
Q1003	8-729-900-80	TRANSISTOR	DTC114ES	R343	1-259-412-11	CARBON	220 5% 1/6W
Q1004	8-729-900-80	TRANSISTOR	DTC114ES	R344	1-259-452-11	CARBON	10K 5% 1/6W
Q1005	8-729-900-80	TRANSISTOR	DTC114ES	R348	1-259-404-11	CARBON	100 5% 1/6W
Q1006	8-729-900-80	TRANSISTOR	DTC114ES	R350	1-259-420-11	CARBON	470 5% 1/6W
Q1007	8-729-900-80	TRANSISTOR	DTC114ES	R401	1-259-476-11	CARBON	100K 5% 1/6W
Q1008	8-729-900-80	TRANSISTOR	DTC114ES	R403	1-259-430-11	CARBON	1. 2K 5% 1/6W
Q1009	8-729-900-80	TRANSISTOR	DTC114ES	R404	1-259-440-11	CARBON	3. 3K 5% 1/6W
Q1010	8-729-900-80	TRANSISTOR	DTC114ES	R405	1-259-404-11	CARBON	100 5% 1/6W
Q1011	8-729-620-05	TRANSISTOR	2SC2603-EF	R406	1-259-396-11	CARBON	47 5% 1/6W
Q1012	8-729-900-80	TRANSISTOR	DTC114ES	R407	1-259-380-11	CARBON	10 5% 1/6W
Q1013	8-729-900-80	TRANSISTOR	DTC114ES	R410	1-259-464-11	CARBON	33K 5% 1/6W
Q1014	8-729-203-49	TRANSISTOR	2SC3327-B	R411	1-259-464-11	CARBON	33K 5% 1/6W
Q1015	8-729-900-80	TRANSISTOR	DTC114ES	R413	1-259-412-11	CARBON	220 5% 1/6W
< RESISTOR >				R414	1-259-412-11	CARBON	220 5% 1/6W
R301	1-259-420-11	CARBON	470 5% 1/6W	R415	1-259-412-11	CARBON	220 5% 1/6W
R302	1-259-420-11	CARBON	470 5% 1/6W	R427	1-259-492-11	CARBON	470K 5% 1/6W
R304	1-259-404-11	CARBON	100 5% 1/6W	R428	1-259-428-11	CARBON	1K 5% 1/6W
R305	1-259-500-11	CARBON	1M 5% 1/6W	R430	1-259-404-11	CARBON	100 5% 1/6W
R306	1-259-476-11	CARBON	100K 5% 1/6W	R433	1-259-396-11	CARBON	47 5% 1/6W
R309	1-259-404-11	CARBON	100 5% 1/6W	R434	1-259-476-11	CARBON	100K 5% 1/6W
R314	1-259-428-11	CARBON	1K 5% 1/6W	R435	1-259-500-11	CARBON	1M 5% 1/6W
R317	1-259-476-11	CARBON	100K 5% 1/6W	R437	1-259-396-11	CARBON	47 5% 1/6W
R318	1-259-464-11	CARBON	33K 5% 1/6W	R448	1-259-476-11	CARBON	100K 5% 1/6W
R319	1-259-468-11	CARBON	47K 5% 1/6W	R451	1-259-476-11	CARBON	100K 5% 1/6W
R320	1-259-440-11	CARBON	3. 3K 5% 1/6W	R453	1-259-430-11	CARBON	1. 2K 5% 1/6W
				R454	1-259-440-11	CARBON	3. 3K 5% 1/6W
				R455	1-259-404-11	CARBON	100 5% 1/6W

DIGITAL

Ref. No.	Part No.	Description	Remark			Ref. No.	Part No.	Description	Remark		
R456	1-259-396-11	CARBON	47	5%	1/6W	R604	1-259-451-11	CARBON	9.1K	5%	1/6W
R460	1-259-464-11	CARBON	33K	5%	1/6W	R605	1-259-444-11	CARBON	4.7K	5%	1/6W
R461	1-259-464-11	CARBON	33K	5%	1/6W	R606	1-259-444-11	CARBON	4.7K	5%	1/6W
R462	1-259-428-11	CARBON	1K	5%	1/6W	R607	1-259-444-11	CARBON	4.7K	5%	1/6W
R463	1-259-428-11	CARBON	1K	5%	1/6W	R608	1-259-444-11	CARBON	4.7K	5%	1/6W
R464	1-259-404-11	CARBON	100	5%	1/6W	R609	1-259-454-11	CARBON	12K	5%	1/6W
R465	1-259-404-11	CARBON	100	5%	1/6W	R610	1-259-454-11	CARBON	12K	5%	1/6W
R467	1-259-420-11	CARBON	470	5%	1/6W	R611	1-259-446-11	CARBON	5.6K	5%	1/6W
R468	1-259-420-11	CARBON	470	5%	1/6W	R612	1-259-446-11	CARBON	5.6K	5%	1/6W
R469	1-259-420-11	CARBON	470	5%	1/6W	R613	1-259-446-11	CARBON	5.6K	5%	1/6W
R478	1-259-428-11	CARBON	1K	5%	1/6W	R614	1-259-446-11	CARBON	5.6K	5%	1/6W
R485	1-259-404-11	CARBON	100	5%	1/6W	R615	1-259-432-11	CARBON	1.5K	5%	1/6W
R501	1-259-451-11	CARBON	9.1K	5%	1/6W	R616	1-259-432-11	CARBON	1.5K	5%	1/6W
R502	1-259-451-11	CARBON	9.1K	5%	1/6W	R651	1-259-451-11	CARBON	9.1K	5%	1/6W
R503	1-259-451-11	CARBON	9.1K	5%	1/6W	R652	1-259-451-11	CARBON	9.1K	5%	1/6W
R504	1-259-451-11	CARBON	9.1K	5%	1/6W	R653	1-259-451-11	CARBON	9.1K	5%	1/6W
R505	1-259-444-11	CARBON	4.7K	5%	1/6W	R654	1-259-451-11	CARBON	9.1K	5%	1/6W
R506	1-259-444-11	CARBON	4.7K	5%	1/6W	R655	1-259-444-11	CARBON	4.7K	5%	1/6W
R507	1-259-444-11	CARBON	4.7K	5%	1/6W	R656	1-259-444-11	CARBON	4.7K	5%	1/6W
R508	1-259-444-11	CARBON	4.7K	5%	1/6W	R657	1-259-444-11	CARBON	4.7K	5%	1/6W
R509	1-259-454-11	CARBON	12K	5%	1/6W	R658	1-259-444-11	CARBON	4.7K	5%	1/6W
R510	1-259-454-11	CARBON	12K	5%	1/6W	R659	1-259-454-11	CARBON	12K	5%	1/6W
R511	1-259-446-11	CARBON	5.6K	5%	1/6W	R660	1-259-454-11	CARBON	12K	5%	1/6W
R512	1-259-446-11	CARBON	5.6K	5%	1/6W	R661	1-259-446-11	CARBON	5.6K	5%	1/6W
R513	1-259-446-11	CARBON	5.6K	5%	1/6W	R662	1-259-446-11	CARBON	5.6K	5%	1/6W
R514	1-259-446-11	CARBON	5.6K	5%	1/6W	R663	1-259-446-11	CARBON	5.6K	5%	1/6W
R515	1-259-432-11	CARBON	1.5K	5%	1/6W	R664	1-259-446-11	CARBON	5.6K	5%	1/6W
R516	1-259-432-11	CARBON	1.5K	5%	1/6W	R665	1-259-432-11	CARBON	1.5K	5%	1/6W
R551	1-259-451-11	CARBON	9.1K	5%	1/6W	R666	1-259-432-11	CARBON	1.5K	5%	1/6W
R552	1-259-451-11	CARBON	9.1K	5%	1/6W	R671	1-259-451-11	CARBON	9.1K	5%	1/6W
R553	1-259-451-11	CARBON	9.1K	5%	1/6W	R672	1-259-451-11	CARBON	9.1K	5%	1/6W
R554	1-259-451-11	CARBON	9.1K	5%	1/6W	R673	1-259-451-11	CARBON	9.1K	5%	1/6W
R555	1-259-444-11	CARBON	4.7K	5%	1/6W	R674	1-259-451-11	CARBON	9.1K	5%	1/6W
R556	1-259-444-11	CARBON	4.7K	5%	1/6W	R675	1-259-444-11	CARBON	4.7K	5%	1/6W
R557	1-259-444-11	CARBON	4.7K	5%	1/6W	R676	1-259-444-11	CARBON	4.7K	5%	1/6W
R558	1-259-444-11	CARBON	4.7K	5%	1/6W	R677	1-259-444-11	CARBON	4.7K	5%	1/6W
R559	1-259-454-11	CARBON	12K	5%	1/6W	R678	1-259-444-11	CARBON	4.7K	5%	1/6W
R560	1-259-454-11	CARBON	12K	5%	1/6W	R679	1-259-454-11	CARBON	12K	5%	1/6W
R561	1-259-446-11	CARBON	5.6K	5%	1/6W	R680	1-259-454-11	CARBON	12K	5%	1/6W
R562	1-259-446-11	CARBON	5.6K	5%	1/6W	R681	1-259-446-11	CARBON	5.6K	5%	1/6W
R563	1-259-446-11	CARBON	5.6K	5%	1/6W	R682	1-259-446-11	CARBON	5.6K	5%	1/6W
R564	1-259-446-11	CARBON	5.6K	5%	1/6W	R683	1-259-446-11	CARBON	5.6K	5%	1/6W
R565	1-259-432-11	CARBON	1.5K	5%	1/6W	R684	1-259-446-11	CARBON	5.6K	5%	1/6W
R566	1-259-432-11	CARBON	1.5K	5%	1/6W	R685	1-259-432-11	CARBON	1.5K	5%	1/6W
R572	1-259-404-11	CARBON	100	5%	1/6W	R686	1-259-432-11	CARBON	1.5K	5%	1/6W
R575	1-259-492-11	CARBON	470K	5%	1/6W	R687	1-259-420-11	CARBON	470	5%	1/6W
R601	1-259-451-11	CARBON	9.1K	5%	1/6W	R688	1-259-420-11	CARBON	470	5%	1/6W
R602	1-259-451-11	CARBON	9.1K	5%	1/6W	R689	1-259-420-11	CARBON	470	5%	1/6W
R603	1-259-451-11	CARBON	9.1K	5%	1/6W	R690	1-259-420-11	CARBON	470	5%	1/6W

DIGITAL

DISPLAY

Ref. No.	Part No.	Description	Remark		
R691	1-259-404-11	CARBON	100	5%	1/6W
R692	1-259-404-11	CARBON	100	5%	1/6W
R693	1-259-420-11	CARBON	470	5%	1/6W
R694	1-259-420-11	CARBON	470	5%	1/6W
R695	1-259-420-11	CARBON	470	5%	1/6W
R696	1-259-420-11	CARBON	470	5%	1/6W
R697	1-259-404-11	CARBON	100	5%	1/6W
R698	1-259-404-11	CARBON	100	5%	1/6W
R1008	1-259-492-11	CARBON	470K	5%	1/6W
R1009	1-259-460-11	CARBON	22K	5%	1/6W
R1011	1-259-428-11	CARBON	1K	5%	1/6W
R1012	1-259-476-11	CARBON	100K	5%	1/6W
R1013	1-259-452-11	CARBON	10K	5%	1/6W
R1014	1-259-428-11	CARBON	1K	5%	1/6W
R1015	1-259-468-11	CARBON	47K	5%	1/6W
R1016	1-259-452-11	CARBON	10K	5%	1/6W
R1017	1-259-412-11	CARBON	220	5%	1/6W
R1019	1-259-476-11	CARBON	100K	5%	1/6W
R1021	1-259-476-11	CARBON	100K	5%	1/6W
R1022	1-259-462-11	CARBON	27K	5%	1/6W
R1023	1-259-454-11	CARBON	12K	5%	1/6W
R1026	1-259-428-11	CARBON	1K	5%	1/6W
R1027	1-259-468-11	CARBON	47K	5%	1/6W
R1028	1-259-468-11	CARBON	47K	5%	1/6W
R1029	1-259-468-11	CARBON	47K	5%	1/6W
R1030	1-259-468-11	CARBON	47K	5%	1/6W
R1031	1-259-468-11	CARBON	47K	5%	1/6W
R1032	1-259-468-11	CARBON	47K	5%	1/6W
R1033	1-259-468-11	CARBON	47K	5%	1/6W
R1034	1-259-468-11	CARBON	47K	5%	1/6W
R1040	1-259-396-11	CARBON	47	5%	1/6W
R1041	1-259-428-11	CARBON	1K	5%	1/6W
R1042	1-259-428-11	CARBON	1K	5%	1/6W
R1043	1-259-428-11	CARBON	1K	5%	1/6W
R1050	1-259-464-11	CARBON	33K	5%	1/6W
R1051	1-259-468-11	CARBON	47K	5%	1/6W
R1052	1-259-468-11	CARBON	47K	5%	1/6W
R1053	1-259-468-11	CARBON	47K	5%	1/6W
R1054	1-259-468-11	CARBON	47K	5%	1/6W
R1055	1-259-468-11	CARBON	47K	5%	1/6W
R1056	1-259-492-11	CARBON	470K	5%	1/6W
R1057	1-259-404-11	CARBON	100	5%	1/6W
R1060	1-259-428-11	CARBON	1K	5%	1/6W
R1061	1-259-428-11	CARBON	1K	5%	1/6W
< VIBRATOR >					
X301	1-577-269-11	VIBRATOR, CRYSTAL (18.432MHz)			
X401	1-577-305-11	VIBRATOR, CRYSTAL (25MHz)			
X1001	1-567-849-11	OSCILLATOR, CERAMIC (20MHz)			

Ref. No.	Part No.	Description	Remark		
*	A-4345-695-A	DISPLAY BOARD, COMPLETE	*****		
	4-933-419-01	HOLDER (FL)			
< CAPACITOR >					
C1001	1-124-918-11	ELECT	47uF	20%	63V
C1003	1-124-126-00	ELECT	47uF	20%	10V
C1004	1-161-379-00	CERAMIC	0.01uF	20%	25V
C1014	1-162-294-31	CERAMIC	0.001uF	10%	50V
< CONNECTOR >					
* CND801	1-564-666-11	PIN, CONNECTOR 10P			
* CND802	1-564-666-11	PIN, CONNECTOR 10P			
* CND803	1-564-342-11	PIN, CONNECTOR 8P			
* CNE3	1-564-513-11	PLUG, CONNECTOR 10P			
< DIODE >					
D1001	8-719-301-52	LED SEL2810A-C (SURROUND)			
D1002	8-719-301-52	LED SEL2810A-C (DYNAMICS)			
D1003	8-719-301-52	LED SEL2810A-C (PARAMETRIC EQ)			
D1007	8-719-301-52	LED SEL2810A-C (ROOM SIZE/WALL)			
D1008	8-719-301-52	LED SEL2810A-C (SEAT POSITION REAR-FRONT/LEFT-RIGHT)			
D1009	8-719-301-52	LED SEL2810A-C (CENTER LEVEL/REAR LEVEL)			
D1010	8-719-301-52	LED SEL2810A-C (EQ LEVEL/FREQUENCY)			
D1011	8-719-301-52	LED SEL2810A-C (MAIN PARAMETER)			
D1012	8-719-301-52	LED SEL2810A-C (SUB PARAMETER)			
D1013	8-719-301-52	LED SEL2810A-C (DIRECT)			
< FLUORESCENT INDICATOR >					
FL1001	1-519-689-11	INDICATOR TUBE, FLUORESCENT			
< IC >					
IC1003	8-759-512-46	IC MSC7162			
IC1004	8-759-512-46	IC MSC7162			
IC1005	8-759-512-46	IC MSC7162			
< RESISTOR >					
R1002	1-249-419-11	CARBON	1.5K	5%	1/4W
R1003	1-249-419-11	CARBON	1.5K	5%	1/4W
R1004	1-249-419-11	CARBON	1.5K	5%	1/4W
R1005	1-249-418-11	CARBON	1.2K	5%	1/4W
R1006	1-249-419-11	CARBON	1.5K	5%	1/4W
R1007	1-249-419-11	CARBON	1.5K	5%	1/4W

DISPLAY

H. P.

I VOL

M VOL

RY

Ref. No.	Part No.	Description	Remark
		< VARIABLE RESISTOR >	
RV1001	1-466-203-11	ENCODER, ROTARY (DIGITAL PROCESSING CONTROL)	
RV1002	1-466-203-11	ENCODER, ROTARY (DIGITAL PROCESSING CONTROL)	
		< SWITCH >	
S1001	1-554-303-21	SWITCH, TACTILE (SURROUND PROGRAM ▽)	
S1002	1-554-303-21	SWITCH, TACTILE (PRESET/USER)	
S1003	1-554-303-21	SWITCH, TACTILE (SORROUND)	
S1004	1-554-303-21	SWITCH, TACTILE (DYNAMICS)	
S1005	1-554-303-21	SWITCH, TACTILE (PARAMETRIC EQ)	
S1006	1-554-303-21	SWITCH, TACTILE (SURROUND PROGRAM △)	
S1007	1-554-303-21	SWITCH, TACTILE (MAIN PARAMETER)	
S1008	1-554-303-21	SWITCH, TACTILE (SUB PARAMETER)	
S1009	1-554-303-21	SWITCH, TACTILE (EQ BAND)	
S1010	1-554-303-21	SWITCH, TACTILE (EQ SLOPE)	
S1011	1-554-303-21	SWITCH, TACTILE (MIX)	
S1012	1-554-303-21	SWITCH, TACTILE (DIGITAL)	
S1013	1-554-303-21	SWITCH, TACTILE (PHONO)	
S1014	1-554-303-21	SWITCH, TACTILE (TUNER)	
S1015	1-554-303-21	SWITCH, TACTILE (CD)	
S1016	1-554-303-21	SWITCH, TACTILE (SOURCE)	
S1017	1-554-303-21	SWITCH, TACTILE (CHECK)	
S1018	1-554-303-21	SWITCH, TACTILE (SET)	
S1019	1-554-303-21	SWITCH, TACTILE (EFFECT REC)	
S1020	1-554-303-21	SWITCH, TACTILE (CHARACTER)	
S1021	1-554-303-21	SWITCH, TACTILE (CLEAR)	
S1022	1-554-303-21	SWITCH, TACTILE (ENTER)	
S1023	1-554-303-21	SWITCH, TACTILE (MEMORY)	
S1024	1-554-303-21	SWITCH, TACTILE (FLAT)	
S1025	1-554-303-21	SWITCH, TACTILE (EQ CH)	
S1026	1-554-303-21	SWITCH, TACTILE (TAPE 2)	
S1027	1-554-303-21	SWITCH, TACTILE (TAPE 1)	
S1028	1-554-303-21	SWITCH, TACTILE (TV)	
S1029	1-554-303-21	SWITCH, TACTILE (LD)	
S1030	1-554-303-21	SWITCH, TACTILE (VIDEO 5)	
S1031	1-554-303-21	SWITCH, TACTILE (VIDEO 4)	
S1032	1-554-303-21	SWITCH, TACTILE (VIDEO 3)	
S1033	1-554-303-21	SWITCH, TACTILE (VIDEO 2)	
S1034	1-554-303-21	SWITCH, TACTILE (VIDEO 1)	
S1035	1-554-303-21	SWITCH, TACTILE (DIGITAL +)	
S1036	1-554-303-21	SWITCH, TACTILE (DIGITAL -)	
S1037	1-554-303-21	SWITCH, TACTILE (PRO LOGIC MODE)	
S1038	1-554-303-21	SWITCH, TACTILE (DIMMER)	

Ref. No.	Part No.	Description	Remark
*	1-642-098-11	H. P. BOARD *****	
		< CONNECTOR >	
* CN6	1-564-518-11	PLUG, CONNECTOR 3P	
		< JACK >	
J850	1-507-982-31	JACK (LARGE TYPE) (HEADPHONES)	

*	1-642-100-11	I VOL BOARD *****	
		< CONNECTOR >	
* CN8	1-564-509-11	PLUG, CONNECTOR 6P	
* CN9	1-564-506-11	PLUG, CONNECTOR 3P	
		< VARIABLE RESISTOR >	
RV101	1-238-248-11	RES, VAR, CARBON 20K/20K (INPUT LEVEL ANAROG)	

*	1-642-104-11	M VOL BOARD *****	
		< CONNECTOR >	
* CN808	1-564-338-00	PIN, CONNECTOR 4P	
		< IC >	
IC801	8-759-820-62	IC LB1639	
		< VARIABLE RESISTOR >	
RV801	1-241-254-21	RES, VAR, CARBON 20KX5 (MASTER VOLUME)	

*	1-642-103-11	RY BOARD *****	
		1-535-476-11 TERMINAL (AEP, G)	
*	1-560-242-61	BUS BAR 2P (US, Canadian, E)	
		< TERMINAL >	
* BP1	1-560-595-00	TERMINAL (WITH BASE) (US, Canadian)	
		< CAPACITOR >	
△C921	1-161-744-00	CERAMIC 0.01uF 400V (US, Canadian)	
△C921	1-161-741-00	CERAMIC 0.001MF 10% 400V (AEP, G, E)	

The components identified by mark △ or dotted line with mark △ are critical for safety. Replace only with part number specified.	Les composants identifiés par une marque △ sont critiques pour la sécurité. Ne les remplacer que par une pièce portant le numéro spécifié.
--	--

RY **SW** **V. S.** **V5** **VIDEO**

Ref. No.	Part No.	Description	Remark
<u>A</u> C922	1-136-279-11	FILM 0.047uF 20% 250V	
		< CONNECTOR >	
* CN807	1-564-336-00	PIN, CONNECTOR 2P	
		< AC OUTLET >	
<u>A</u> CNJ901	1-540-059-21	OUTLET, AC (POLAR) (AC OUTLET) (US, Canadian)	
<u>A</u> CNJ901	1-540-040-21	OUTLET, AC (NONPOLAR) (2P) (AC OUTLET) (E)	
<u>A</u> CNJ902	1-540-059-21	OUTLET, AC (POLAR) (AC OUTLET) (US, Canadian)	
<u>A</u> CNJ902	1-540-040-21	OUTLET, AC (NONPOLAR) (2P) (AC OUTLET) (E)	
		< FUSE HOLDER >	
<u>A</u> FJ901	1-533-189-11	HOLDER, FUSE (US, Canadian, AEP, G)	
<u>A</u> FJ902	1-533-189-11	HOLDER, FUSE (AEP, G)	
		< RELAY >	
<u>A</u> RY901	1-515-701-11	RELAY (US, Canadian)	
<u>A</u> RY901	1-515-617-11	RELAY (AEP, G, E)	
		< TRANSFORMER >	
<u>A</u> T902	1-421-960-11	TRANSFORMER, LINE FILTER	
		< CONNECTOR >	
* VH1	1-564-321-00	PIN, CONNECTOR 2P	

*	1-642-096-11	SW BOARD	

		< CONNECTOR >	
* CND806	1-564-340-00	PIN, CONNECTOR 6P	
		< DIODE >	
D1050	8-719-301-37	LED SEL2210S-CD (POWER) (AEP, E, G)	
		< IC >	
IC1050	8-749-920-83	IC GP1U52XB	
		< TRANSISTOR >	
Q1031	8-729-900-80	TRANSISTOR DTC114ES (AEP, G, E)	
Q1032	8-729-900-80	TRANSISTOR DTC114ES (AEP, G, E)	
		< RESISTOR >	
R1035	1-259-452-11	CARBON 10K 5% 1/6W (AEP, G, E)	

Ref. No.	Part No.	Description	Remark
R1036	1-259-418-11	CARBON 390 5% 1/6W (AEP, G, E)	
		< SWITCH >	
S1050	1-554-303-21	SWITCH, TACTILE (POWER)	

*	1-642-404-11	V. S. BOARD (E)	

*	1-564-687-11	PIN, CONNECTOR 3P (E)	
		< FUSE HOLDER >	
FJ903	1-533-189-11	HOLDER, FUSE (E)	
FJ904	1-533-189-11	HOLDER, FUSE (E)	
		< CONNECTOR >	
* VH2	1-564-321-00	PIN, CONNECTOR 2P (E)	
		< SWITCH >	
<u>A</u> S901	1-572-009-11	SELECTOR, VOLTAGE (VOLTAGE SELECTOR) (E)	

*	1-642-102-11	V5 BOARD	

		< CONNECTOR >	
* CN1	1-564-505-11	PLUG, CONNECTOR 2P	
* CN11	1-564-506-11	PLUG, CONNECTOR 3P	
		< JACK >	
J810	1-563-136-61	JACK, PIN (VIDEO 5 INPUT)	

*	A-4347-548-A	VIDEO BOARD, COMPLETE	

		< CAPACITOR >	
C701	1-124-471-00	ELECT 1000uF 20% 6.3V	
C702	1-124-471-00	ELECT 1000uF 20% 6.3V	
C703	1-124-471-00	ELECT 1000uF 20% 6.3V	
C704	1-124-471-00	ELECT 1000uF 20% 6.3V	
C705	1-124-471-00	ELECT 1000uF 20% 6.3V	
C709	1-124-907-11	ELECT 10uF 20% 50V	
C710	1-124-907-11	ELECT 10uF 20% 50V	
C711	1-161-379-00	CERAMIC 0.01uF 20% 25V	
C712	1-161-379-00	CERAMIC 0.01uF 20% 25V	
C713	1-161-379-00	CERAMIC 0.01uF 20% 25V	
C714	1-136-165-00	FILM 0.1uF 5% 50V	

The components identified by mark <u>A</u> or dotted line with mark <u>A</u> are critical for safety. Replace only with part number specified.	Les composants identifiés par une marque <u>A</u> sont critiques pour la sécurité. Ne les remplacer que par une pièce portant le numéro spécifié.
--	---

VIDEO

Ref. No.	Part No.	Description	Remark	Ref. No.	Part No.	Description	Remark
C715	1-136-165-00	FILM	0.1uF 5% 50V	J704	1-568-751-71	JACK, PIN (2P SHIELD TYPE) (MONITOR VIDEO OUT 1/2)	
C716	1-136-165-00	FILM	0.1uF 5% 50V	J705	1-566-846-21	CONNECTOR, (S) TERMINAL 4P (VIDEO 2 S VIDEO OUT)	
C717	1-124-471-00	ELECT	1000uF 20% 6.3V	J706	1-566-846-21	CONNECTOR, (S) TERMINAL 4P (VIDEO 2 S VIDEO IN)	
C718	1-124-471-00	ELECT	1000uF 20% 6.3V	J707	1-566-846-21	CONNECTOR, (S) TERMINAL 4P (VIDEO 1 S VIDEO OUT)	
C719	1-124-471-00	ELECT	1000uF 20% 6.3V	J708	1-566-846-21	CONNECTOR, (S) TERMINAL 4P (VIDEO 1 S VIDEO IN)	
C720	1-124-907-11	ELECT	10uF 20% 50V	J711	1-566-846-21	CONNECTOR, (S) TERMINAL 4P (MONITOR S VIDEO OUT)	
C721	1-124-907-11	ELECT	10uF 20% 50V			< COIL >	
C724	1-136-165-00	FILM	0.1uF 5% 50V	L701	1-410-521-11	INDUCTOR	100uH
C725	1-124-907-11	ELECT	10uF 20% 50V	L702	1-410-521-11	INDUCTOR	100uH
C726	1-124-907-11	ELECT	10uF 20% 50V	L703	1-410-521-11	INDUCTOR	100uH
C727	1-161-379-00	CERAMIC	0.01uF 20% 25V	L704	1-410-521-11	INDUCTOR	100uH
C728	1-161-379-00	CERAMIC	0.01uF 20% 25V			< TRANSISTOR >	
C729	1-126-101-11	ELECT	100uF 20% 16V	Q701	8-729-119-76	TRANSISTOR	2SA1175-HFE
C730	1-126-101-11	ELECT	100uF 20% 16V	Q702	8-729-119-76	TRANSISTOR	2SA1175-HFE
C731	1-126-101-11	ELECT	100uF 20% 16V	Q703	8-729-119-76	TRANSISTOR	2SA1175-HFE
C732	1-126-101-11	ELECT	100uF 20% 16V	Q704	8-729-119-76	TRANSISTOR	2SA1175-HFE
C733	1-126-101-11	ELECT	100uF 20% 16V	Q705	8-729-119-76	TRANSISTOR	2SA1175-HFE
C734	1-124-907-11	ELECT	10uF 20% 50V	Q706	8-729-900-74	TRANSISTOR	DTC143TS
C735	1-126-044-11	ELECT	1uF 20% 50V	Q707	8-729-900-74	TRANSISTOR	DTC143TS
C736	1-126-101-11	ELECT	100uF 20% 16V	Q708	8-729-900-74	TRANSISTOR	DTC143TS
C743	1-126-101-11	ELECT	100uF 20% 16V	Q709	8-729-119-76	TRANSISTOR	2SA1175-HFE
C744	1-162-294-31	CERAMIC	0.001uF 10% 50V	Q710	8-729-119-76	TRANSISTOR	2SA1175-HFE
		< CONNECTOR >		Q711	8-729-119-76	TRANSISTOR	2SA1175-HFE
* CND804	1-564-339-00	PIN, CONNECTOR 5P		Q712	8-729-119-76	TRANSISTOR	2SA1175-HFE
* CND805	1-564-340-00	PIN, CONNECTOR 6P		Q713	8-729-620-05	TRANSISTOR	2SC2603-EF
* CNE1	1-564-508-11	PLUG, CONNECTOR 5P		Q715	8-729-620-05	TRANSISTOR	2SC2603-EF
		< DIODE >				< RESISTOR >	
D701	8-719-987-63	DIODE	1N4148M	R701	1-247-804-11	CARBON	75 5% 1/4W
D702	8-719-987-63	DIODE	1N4148M	R702	1-247-804-11	CARBON	75 5% 1/4W
D703	8-719-987-63	DIODE	1N4148M	R703	1-247-804-11	CARBON	75 5% 1/4W
		< IC >		R704	1-247-804-11	CARBON	75 5% 1/4W
IC701	8-759-805-14	IC	LC7822	R705	1-247-804-11	CARBON	75 5% 1/4W
IC702	8-759-805-14	IC	LC7822	R706	1-247-804-11	CARBON	75 5% 1/4W
IC703	8-759-057-42	IC	MC14576BP	R707	1-247-804-11	CARBON	75 5% 1/4W
IC704	8-759-805-15	IC	LC7823	R708	1-247-804-11	CARBON	75 5% 1/4W
IC705	8-759-805-15	IC	LC7823	R709	1-247-804-11	CARBON	75 5% 1/4W
IC706	8-759-057-42	IC	MC14576BP	R710	1-247-804-11	CARBON	75 5% 1/4W
IC707	8-759-057-42	IC	MC14576BP	R711	1-247-804-11	CARBON	75 5% 1/4W
		< JACK >		R712	1-247-804-11	CARBON	75 5% 1/4W
J701	1-568-752-61	JACK, PIN (3P SHIELD TYPE) (TV/LD/VIDEO 4 VIDEO IN)		R713	1-249-429-11	CARBON	10K 5% 1/4W
J702	1-568-752-61	JACK, PIN (3P SHIELD TYPE) (VIDEO 2 VIDEO OUT, VIDEO 3 VIDEO IN/OUT)		R714	1-249-429-11	CARBON	10K 5% 1/4W
J703	1-568-752-61	JACK, PIN (3P SHIELD TYPE) (VIDEO 1 VIDEO IN/OUT, VIDEO 2 VIDEO OUT)					

VIDEO

VOL LED

YC

Ref. No.	Part No.	Description	Remark
R715	1-249-429-11	CARBON	10K 5% 1/4W
R716	1-249-429-11	CARBON	10K 5% 1/4W
R717	1-249-429-11	CARBON	10K 5% 1/4W
R718	1-249-413-11	CARBON	470 5% 1/4W
R719	1-249-413-11	CARBON	470 5% 1/4W
R720	1-249-413-11	CARBON	470 5% 1/4W
R721	1-249-413-11	CARBON	470 5% 1/4W
R722	1-249-413-11	CARBON	470 5% 1/4W
R723	1-249-405-11	CARBON	100 5% 1/4W
R725	1-249-405-11	CARBON	100 5% 1/4W
R727	1-249-421-11	CARBON	2. 2K 5% 1/4W
R729	1-249-421-11	CARBON	2. 2K 5% 1/4W
R731	1-249-421-11	CARBON	2. 2K 5% 1/4W
R733	1-249-428-11	CARBON	8. 2K 5% 1/4W
R735	1-247-804-11	CARBON	75 5% 1/4W
R736	1-247-804-11	CARBON	75 5% 1/4W
R737	1-247-804-11	CARBON	75 5% 1/4W
R738	1-247-804-11	CARBON	75 5% 1/4W
R739	1-247-804-11	CARBON	75 5% 1/4W
R740	1-247-804-11	CARBON	75 5% 1/4W
R741	1-247-804-11	CARBON	75 5% 1/4W
R742	1-247-804-11	CARBON	75 5% 1/4W
R743	1-247-804-11	CARBON	75 5% 1/4W
R744	1-247-804-11	CARBON	75 5% 1/4W
R749	1-247-804-11	CARBON	75 5% 1/4W
R750	1-247-804-11	CARBON	75 5% 1/4W
R751	1-249-429-11	CARBON	10K 5% 1/4W
R752	1-249-429-11	CARBON	10K 5% 1/4W
R753	1-249-429-11	CARBON	10K 5% 1/4W
R754	1-249-429-11	CARBON	10K 5% 1/4W
R755	1-249-429-11	CARBON	10K 5% 1/4W
R756	1-249-429-11	CARBON	10K 5% 1/4W
R757	1-249-413-11	CARBON	470 5% 1/4W
R758	1-249-413-11	CARBON	470 5% 1/4W
R759	1-249-413-11	CARBON	470 5% 1/4W
R760	1-249-413-11	CARBON	470 5% 1/4W
R763	1-249-405-11	CARBON	100 5% 1/4W
R765	1-249-405-11	CARBON	100 5% 1/4W
R767	1-249-405-11	CARBON	100 5% 1/4W
R769	1-249-405-11	CARBON	100 5% 1/4W
R772	1-249-422-11	CARBON	2. 7K 5% 1/4W
R773	1-249-441-11	CARBON	100K 5% 1/4W
R774	1-249-441-11	CARBON	100K 5% 1/4W
R775	1-249-441-11	CARBON	100K 5% 1/4W
R776	1-249-428-11	CARBON	8. 2K 5% 1/4W
R777	1-249-429-11	CARBON	10K 5% 1/4W
R778	1-249-422-11	CARBON	2. 7K 5% 1/4W
R780	1-249-439-11	CARBON	68K 5% 1/4W
R781	1-247-887-00	CARBON	220K 5% 1/4W

Ref. No.	Part No.	Description	Remark
R782	1-247-887-00	CARBON	220K 5% 1/4W
R783	1-247-887-00	CARBON	220K 5% 1/4W
R784	1-247-895-00	CARBON	470K 5% 1/4W
R785	1-247-895-00	CARBON	470K 5% 1/4W
R786	1-249-405-11	CARBON	100 5% 1/4W
R787	1-249-429-11	CARBON	10K 5% 1/4W
R788	1-249-429-11	CARBON	10K 5% 1/4W
R789	1-249-413-11	CARBON	470 5% 1/4W

*	1-642-097-11	VOL LED BOARD	

		< DIODE >	
D1051	8-719-301-37	LED SEL2210S-CD (VOLUME)	

*	1-642-099-11	YC BOARD	

		< CAPACITOR >	
C740	1-101-004-00	CERAMIC 0.01uF	50V
		< CONNECTOR >	
* CN1A	1-564-506-11	PLUG, CONNECTOR 3P	
		< JACK >	
J801	1-566-847-21	CONNECTOR, (S) TERMINAL 4P (VIDEO 5 INPUT S VIDEO)	

Ref. No.	Part No.	Description	Remark
MISCELLANEOUS *****			
△8	1-559-479-11	CORD, POWER (US, Canadian)	
△15	1-551-238-00	CORD, POWER 3 CORE (AEP, G)	
△23	1-559-297-31	CODE, POWER (E)	
24	1-569-007-11	ADAPTER, CONVERSION 2P (E)	
△25	1-526-988-11	OUTLET, AC (CEE) (AEP, G)	
31	1-543-619-41	CORE, RING (US, Canadian, G)	
32	1-543-824-11	CORE, TROIDAL (US, Canadian, G)	
68	1-452-419-21	MAGNET	
80	1-543-786-11	CLAMP, SLEEVE FERRITE (US, Canadian, G)	
△F901	1-532-613-XX	FUSE, TIME-LAG (250V 0.2A) (AEP, G)	
△F901	1-532-740-11	FUSE, GLASS TUBE (US, Canadian)	
△F902	1-532-299-00	FUSE, TIME-LAG (T5A) (AEP, G)	
△F903	1-532-284-00	FUSE, TIME-LAG (T6.3A) (E)	
△F904	1-532-284-00	FUSE, TIME-LAG (T6.3A) (E)	
△T901	1-449-835-11	TRANSFORMER, POWER (US, Canadian)	
△T901	1-449-881-11	TRANSFORMER, POWER (AEP, G)	
△T901	1-449-883-11	TRANSFORMER, POWER (E)	

ACCESSORIES & PACKING MATERIALS

	1-465-844-11	REMOTE COMMANDER (RM-P2000)	
	1-543-827-11	CLAMP, SLEEVE FERRITE (US, Canadian, G)	
	1-558-271-11	CORD, CONNECTION	
*	2-135-414-01	SHEET, PROTECTION	
	3-703-450-01	INSTRUCTION (US)	
*	3-703-713-41	STICKER, SONY SYMBOL (10) (US, Canadian)	
	3-704-366-01	SCREW (CASE) (M3X8) (AEP, G, E)	
	3-704-366-31	SCREW (CASE) (M3X6) (US, Canadian)	
	3-754-484-11	MANUAL, INSTRUCTION (ENGLISH, FRENCH, SPANISH, PORTUGUESE) (AEP, E)	
	3-754-484-21	MANUAL, INSTRUCTION (ENGLISH) (US, Canadian)	
	3-754-484-31	MANUAL, INSTRUCTION (FRENCH) (Canadian)	
	3-754-484-41	MANUAL, INSTRUCTION (GERMAN, DUTCH, SWEDISH, ITALIAN) (AEP, G)	
*	4-933-001-01	CUSHION	
*	4-951-278-01	INDIVIDUAL CARTON	

HARDWARE LIST

#1	7-685-646-79	SCREW +BTP	3X8	TYPE2 N-S
#2	7-682-547-09	SCREW +BVTT	3X6	(S)
#3	7-682-548-09	SCREW +BVTT	3X8	(S)
#4	7-682-561-04	SCREW +BVTT	4X8	(S) (AEP, G)
#5	7-623-210-22	SW 4, TYPE 2		(AEP, G)

<p>The components identified by mark △ or dotted line with mark △ are critical for safety. Replace only with part number specified.</p>	<p>Les composants identifiés par une marque △ sont critiques pour la sécurité. Ne les remplacer que par une pièce portant le numéro spécifié.</p>
---	---

TA-E2000ESD

SONY[®]
SERVICE MANUAL

US Model
Canadian Model
AEP Model
E Model

SUPPLEMENT-1

SUBJECT : BLOCK DIAGRAMS

File this supplement with the Service Manual.

BLOCK DIAGRAM—VIDEO/DISPLAY SECTION—

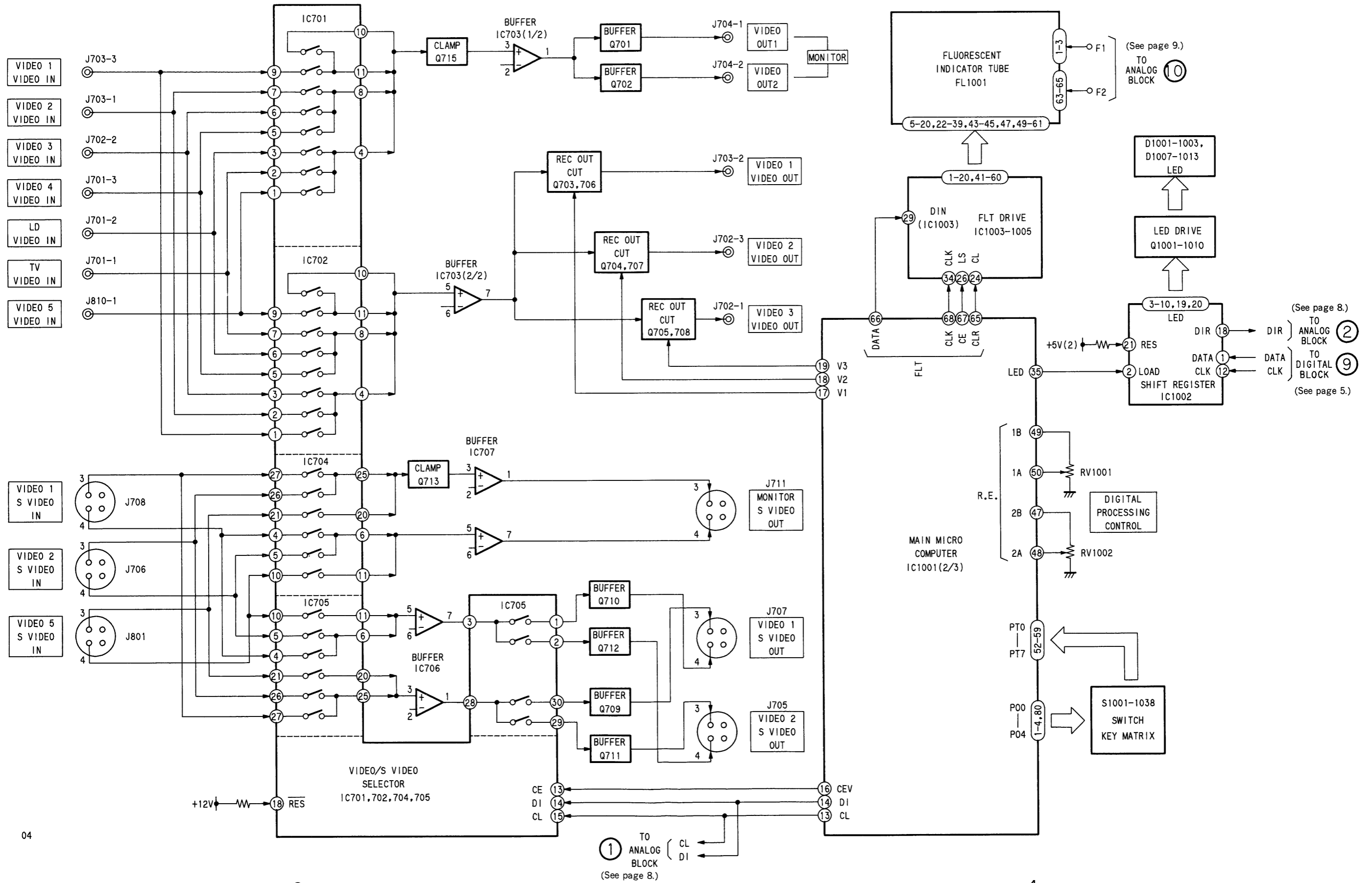

BLOCK DIAGRAM—DIGITAL SECTION—

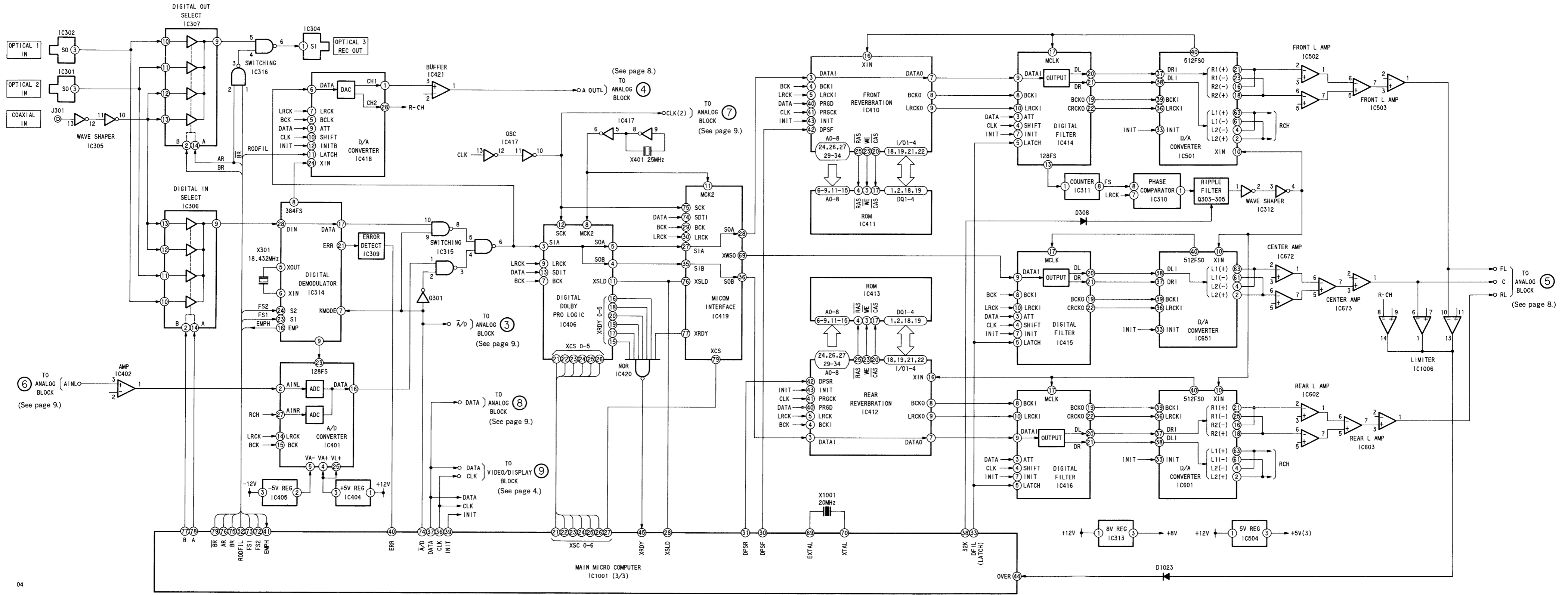

BLOCK DIAGRAM—ANALOG SECTION—

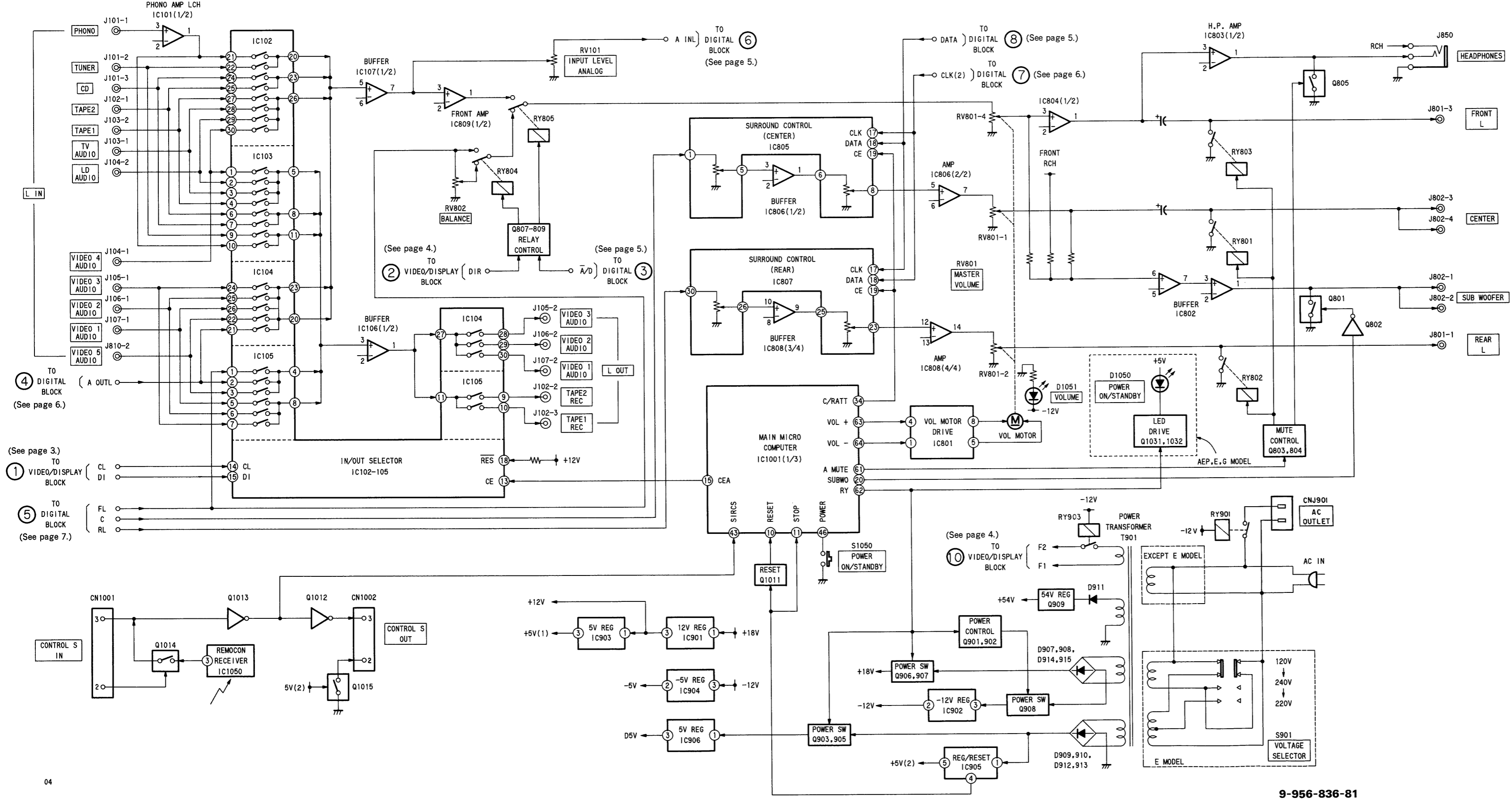

④ TO DIGITAL BLOCK (See page 6.)

① TO VIDEO/DISPLAY BLOCK (See page 3.)

⑤ TO DIGITAL BLOCK (See page 7.)

⑥ TO DIGITAL BLOCK (See page 5.)

⑧ TO DIGITAL BLOCK (See page 5.)

⑦ TO DIGITAL BLOCK (See page 6.)

② TO VIDEO/DISPLAY (DIR) BLOCK (See page 4.)

③ TO DIGITAL BLOCK (A/D) (See page 5.)

⑩ TO VIDEO/DISPLAY BLOCK (See page 4.)

TA-E2000ESD

SONY SERVICE MANUAL

*US Model
Canadian Model
AEP Model
E Model*

SUPPLEMENT-2

File this supplement with the service manual.

Subject : US model disuse the side panel.

• Difference Parts

Page	Ref.No.	Part No.	Description
34	5	3-704-366-31	SCREW (CASE) (M3×6)