

TA-F110/F210

SERVICE MANUAL

AEP Model

UK Model

TA-F110/F210

E Model

TA-F110



Photo: TA-F210

SPECIFICATIONS

Amplifier

Continuous RMS power output (both channels driven simultaneously)

AEP model

		TA-F110	TA-F210
DIN, 1 kHz	4 ohms	40W + 40W	80W + 80W
	8 ohms	30W + 30W	57W + 57W
20 Hz – 20 kHz THD 0.05%	4 ohms	27W + 27W	50W + 50W
	8 ohms	24W + 24W	40W + 40W

UK, E model

		TA-F110	TA-F210
DIN, 1 kHz, 8 ohms		40W + 40W	70W + 70W
20 Hz – 20 kHz THD 0.05%, 8 ohms		30W + 30W	50W + 50W

Input

Input jack		Jack type	Sensitivity
PHONO	MM	Phono	2.0 mV
TUNER, CD, VIDEO/AUX, TAPE/DAT		Phono	150 mV
Impedance	S/N (weighting network, input level)		
50 kilohms	70 dB (A, 2 mV)		
50 kilohms	100 dB (150 mV)		

Output

Output jack	Jack type	Voltage/impedance
REC OUT	Phono jacks	Voltage 150 mV Impedance 1 kohms
SPEAKERS	—	AEP model: Accepts speakers of 4 – 16 ohms. UK, E model: Accepts speakers of 8 – 16 ohms.
HEAD- PHONES	Stereo phone jack	Accepts low and high impedance headphones.

Tone controls

	Response	Turnover frequency
BASS	±7 dB (100 Hz)	500 Hz
TREBLE	±8 dB (15 kHz)	3 kHz

Loudness (Attenuation 30 dB) (TA-F210 only)
+3 dB (100 Hz)
+3 dB (10 kHz)

— Continued on next page —

INTEGRATED STEREO AMPLIFIER
SONY®

Harmonic distortion Less than 0.05% at rated output
 Intermodulation (IM) distortion (60 Hz:7 kHz = 4:1) Less than 0.05% at rated output
 Frequency response
 PHONO: RIAA equalization curve
 ±0.5 dB
 TUNER, CD, VIDEO/AUX, TAPE1,
 TAPE2/DAT: 7 Hz – 100 kHz ±3 dB
 Residual noise Less than 170 μV (network A)
 Damping factor 40 (8 ohms, 1 kHz)

General

System Preamplifier: Low-noise, high-gain equalizer amplifier
 Power amplifier: Pure-complementary SEPP OCL power amplifier with all stages directly coupled
 Power requirements AEP model: 220 V AC, 50 Hz
 UK model: 240 V AC, 50 Hz
 E model: 120 V, 220 V or 240 V AC adjustable, 50/60 Hz
 Power consumption AEP model:
 TA-F110: 90W
 TA-F210: 150W
 UK model:
 TA-F110: 160W
 TA-F210: 260W
 E model:
 TA-F110: 70W
 Dimensions Approx. 430 × 135 × 315 mm (w/h/d)
 (17 × 5 3/8 × 12 1/2 inches)
 Weight AEP model:
 TA-F110: Approx. 5.7 kg (12 lb 9 oz)
 TA-F210: Approx. 7.4 kg (16 lb 5 oz)
 UK model:
 TA-F110: Approx. 5.6 kg (12 lb 6 oz)
 TA-F210: Approx. 6.8 kg (15 lb)
 E model:
 TA-F110: Approx. 5.6 kg (12 lb 6 oz)

Design and specifications subject to change without notice.

MODEL IDENTIFICATION

– Specification Label –

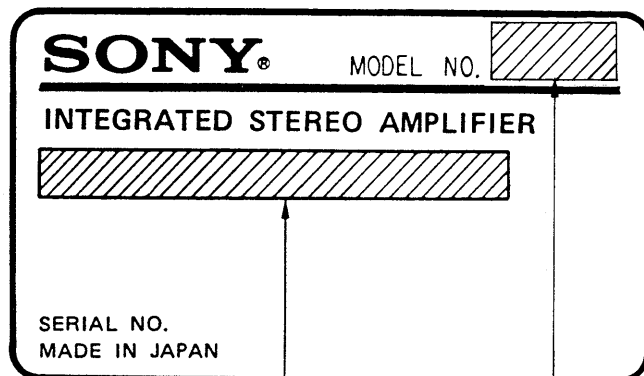

TA-F110:
 AEP Model: AC: 220 V ~ 50/60 Hz
 UK Model: AC: 240 V ~ 50/60 Hz
 E Model: AC: 120, 220, 240 V ~ 50/60 Hz

TA-F210:
 AEP Model: AC: 220 V ~ 50/60 Hz
 UK Model: AC: 240 V ~ 50/60 Hz



On operating voltage

Before operating the unit, check that the operating voltage of your unit is identical with the voltage of your local power supply.

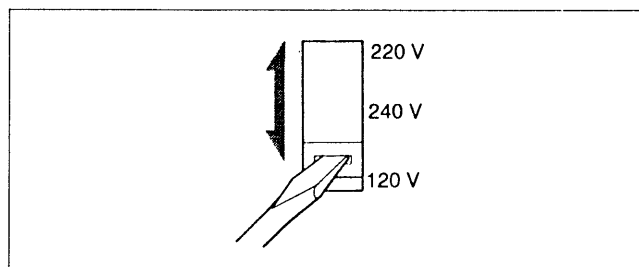
Where purchased	Operating voltage
UK model	240 V AC
AEP model	220 V AC
E model	120 V, 220 V or 240 V AC adjustable The voltage selector is located on the rear panel. If the selector must be reset, disconnect the AC power cord and set the selector to the proper voltage of your local power supply.



SAFETY-RELATED COMPONENT WARNING!!

COMPONENTS IDENTIFIED BY MARK  OR DOTTED LINE WITH MARK  ON THE SCHEMATIC DIAGRAMS AND IN THE PARTS LIST ARE CRITICAL TO SAFE OPERATION. REPLACE THESE COMPONENTS WITH SONY PARTS WHOSE PART NUMBERS APPEAR AS SHOWN IN THIS MANUAL OR IN SUPPLEMENTS PUBLISHED BY SONY.

Parts Identification

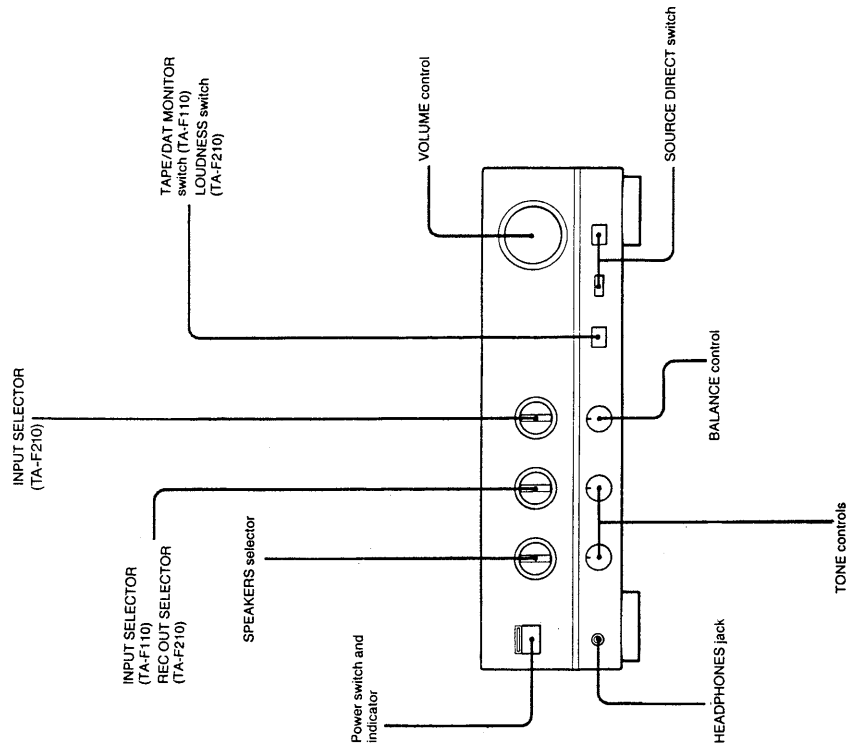

SECTION 1 GENERAL

Connections

Notes on Connection

- Connect the AC power cord last. Make sure power is off.
- Cord plugs and jacks are color coded. Red plugs and jacks are for right channel (R) and white ones for left channel (L).
- Fully insert cable connectors into jacks. Loose connections may cause hum or noise.

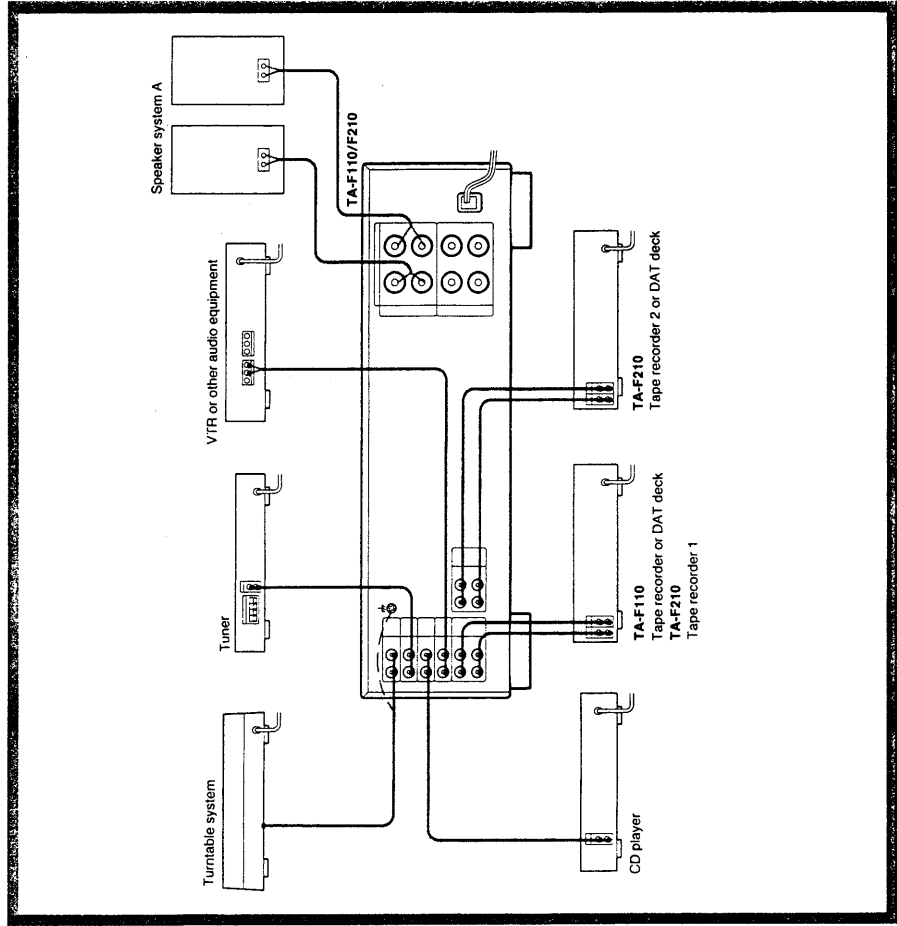

SECTION 2 BLOCK DIAGRAM

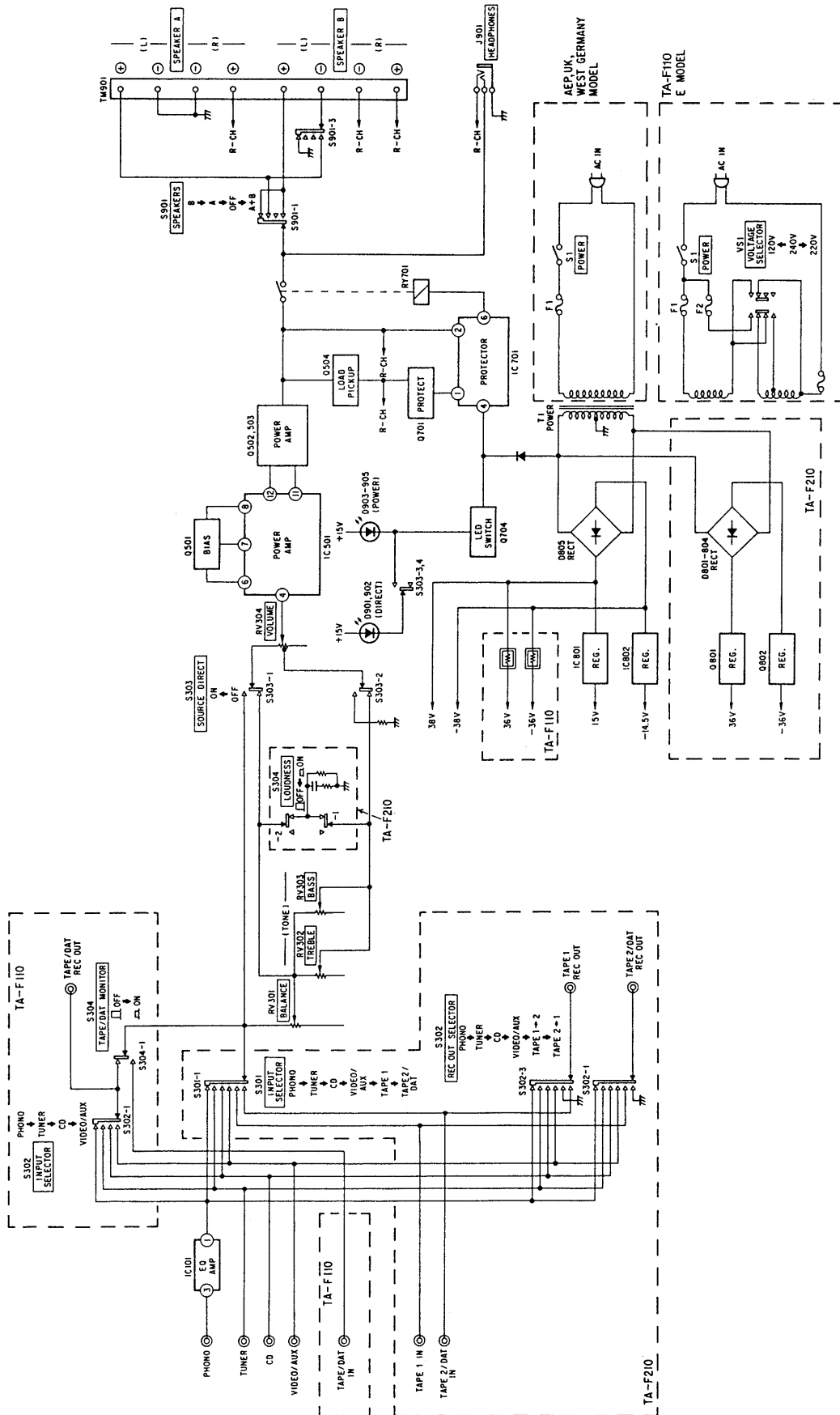

SECTION 3 ELECTRICAL ADJUSTMENTS

NOTE:

- Adjustment should be performed 10 minutes after the POWER switch is on (POWER ON).

Bias Current Adjustment

Note: This adjustment should be performed under thermal stable condition. Before starting the adjustment, wait for more than an hour after switch off for cooling, and perform the adjustment within one minute after switching on.

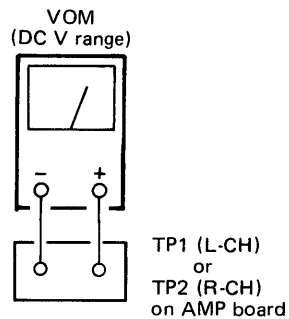

Procedure :

1. Set main volume to minimum position.
2. Switch on the set.
3. Adjust RV501 (RV601 for right channel) so that the voltage across TP1 and TP2 becomes the value indicated below.

Adjustment values :

TA-F110 $4\text{mV} \pm 0.3\text{mV}$

TA-F210 $2\text{mV} \pm 0.3\text{mV}$

Adjustment Location:

[AMP BOARD] – Component Side –

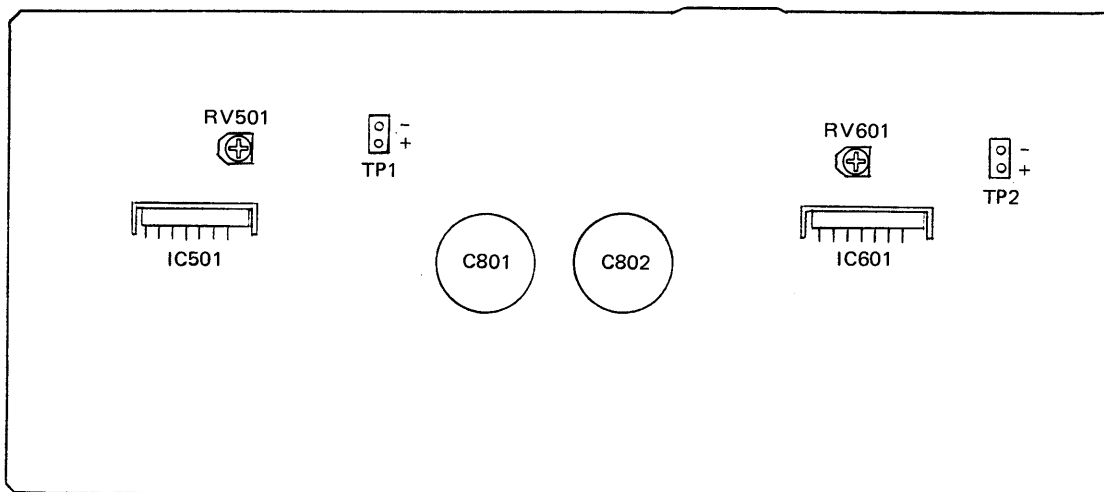

SECTION 4 DIAGRAMS

4-1. CIRCUIT BOARDS LOCATION

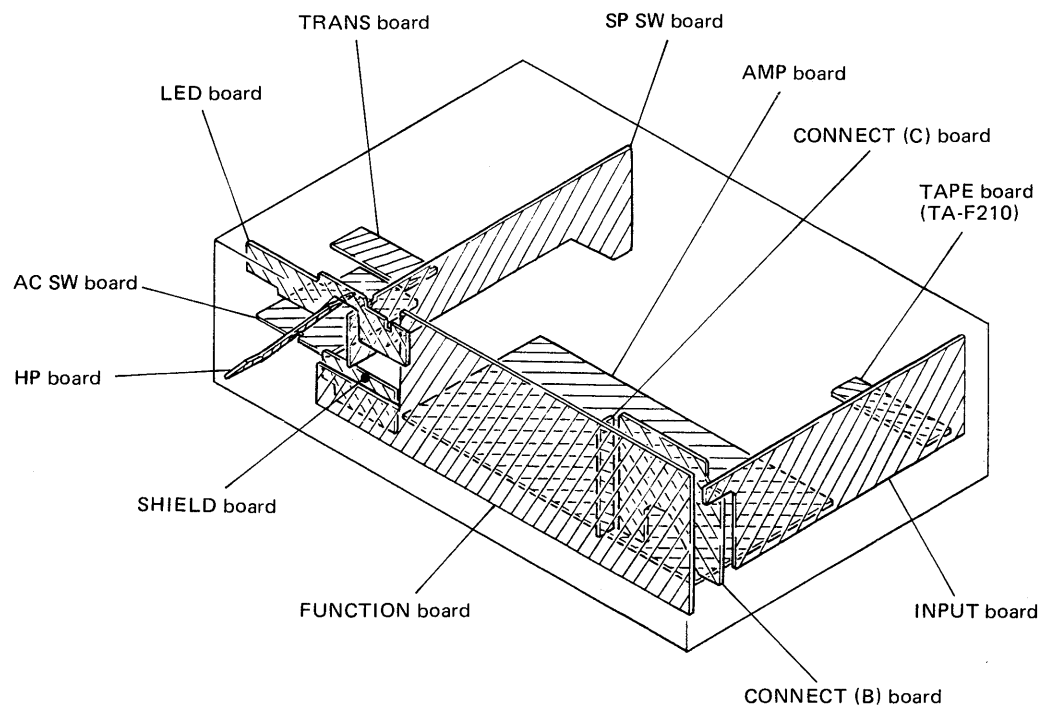

4-2. SEMICONDUCTOR LEAD LAYOUTS

M5F7815

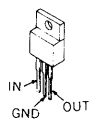
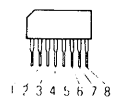
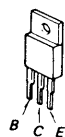
 μ PC1237HA2SA1670-OPY-LF
2SA1671-OPY-LF
2SC4385-OPY-LF
2SC4386-OPY-LF2SB734-34
2SD774-3

2SC2785HFE

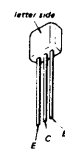
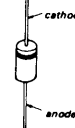
US1060M
1S1585
10E2N

SEL2510W

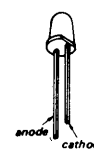

M5F7915

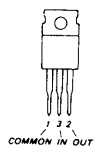
DTA124ES
2SC2458

2SC1841

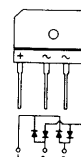
RBA-402
RBV-602-01

SEL2510C

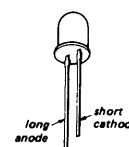

4-3. IC BLOCK DIAGRAMS

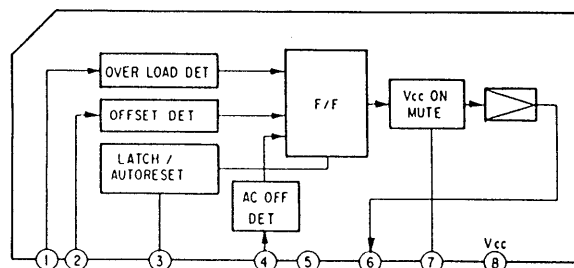
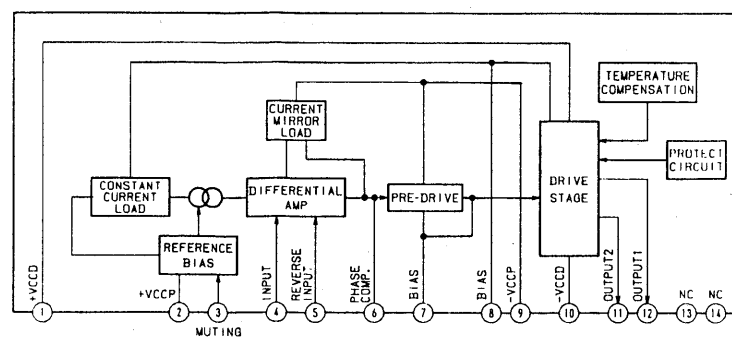
IC701 μ PC1237HAIC501, 601 μ PC1298V

Note:
 • : parts extracted from the component side.

• Semiconductor Location

Ref. No.	Location
D501	C-17
D502	C-18
D601	C-11
D602	C-11
D701	E-18
D702	D-19
D703	D-19
D801	E-14 (F210)
D802	E-14 (F210)
D803	E-14 (F210)
D804	E-14 (F210)
D805	E-15
D901	G-33
D902	G-33
D903	G-17
D904	G-17
D905	G-17
IC101	K-12
IC501	D-20
IC601	D-13
IC701	E-19
IC801	E-11
IC802	E-12
Q501	B-19
Q502	A-20
Q503	A-18
Q504	B-17
Q601	B-13
Q602	A-14
Q603	A-12
Q604	B-11
Q701	E-18
Q704	E-20
Q801	E-13 (F210)
Q802	E-14 (F210)

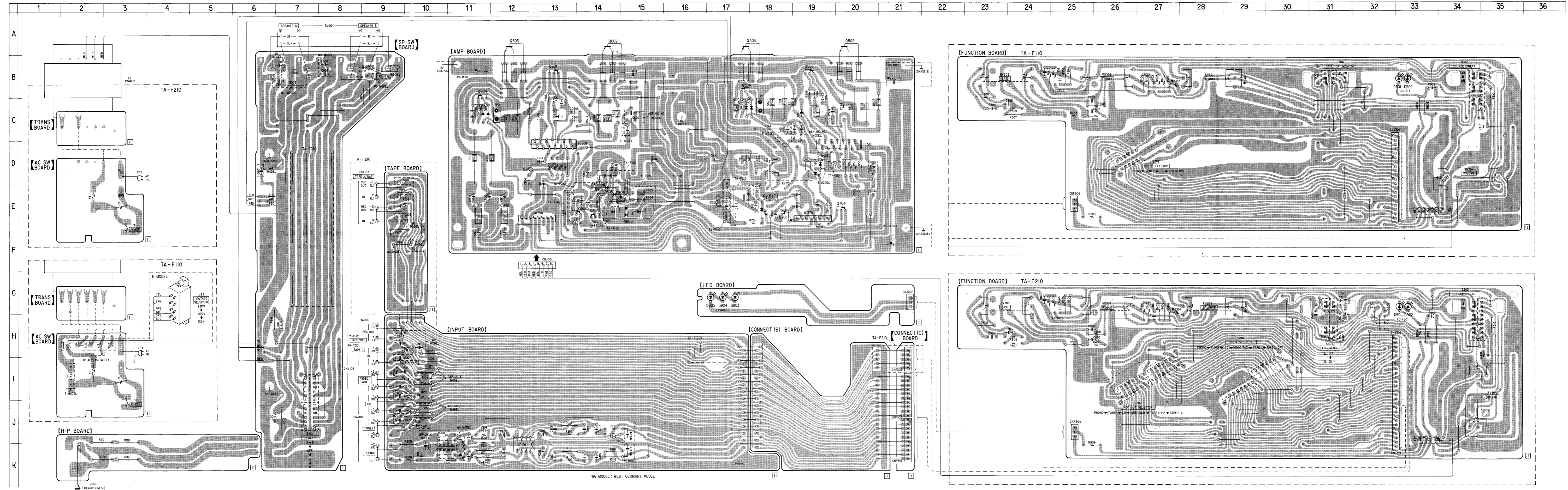

4-5. SCHEMATIC DIAGRAM • See page 6 for IC Block Diagrams.

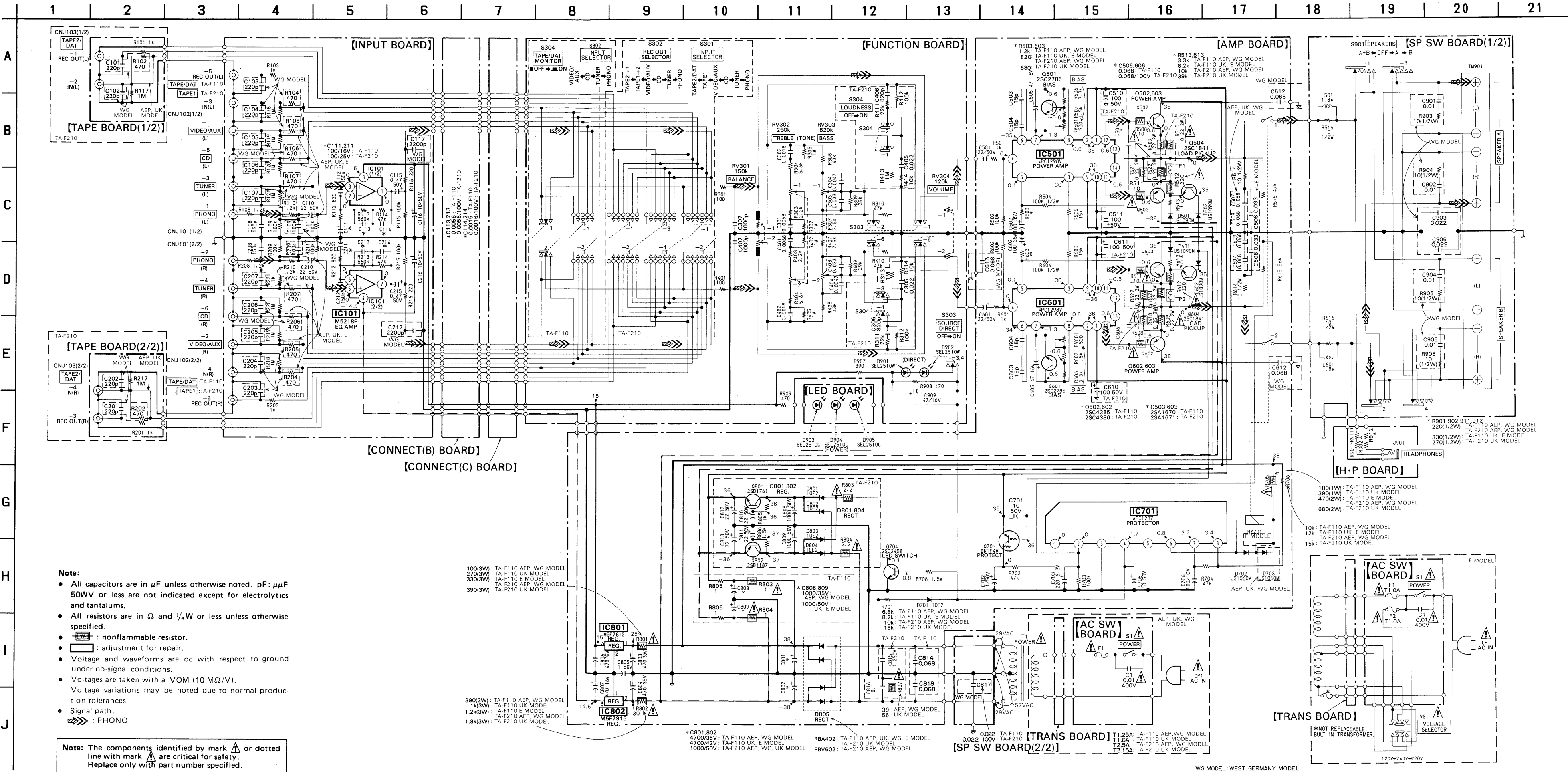

Note:

- All capacitors are in μF unless otherwise noted. pF: μmF 50WV or less are not indicated except for electrolytics and tantalums.
- All resistors are in Ω and $\frac{1}{4}W$ or less unless otherwise specified.
- : nonflammable resistor.
- : adjustment for repair.
- Voltage and waveforms are dc with respect to ground under no-signal conditions.
- Voltages are taken with a VOM (10 M Ω /V). Voltage variations may be noted due to normal production tolerances.
- Signal path.
- : PHONO

Note: The components identified by mark or dotted line with mark are critical for safety. Replace only with part number specified.

WG MODEL: WEST GERMANY MODEL

SECTION 6 EXPLODED VIEWS

NOTE:

- The mechanical parts with no reference number in the exploded views are not supplied.
- The construction parts of an assembled part are indicated with a collation number in the remark column.
- Items marked "★" are not stocked since they are seldom required for routine service. Some delay should be anticipated when ordering these items.

- Due to standardization, parts with part number suffix -XX and -X may be different from the parts specified in the components used on the set.
- Color Indication of Appearance Parts Example:
(RED) ... KNOB, BALANCE (WHITE)
↑ Cabinet's Color ↑ Parts Color

The components identified by mark or dotted line with mark are critical for safety. Replace only with part number specified.

- Abbreviation
WG: West Germany Model
- Illustration
Mainly TA-F210

(1) FRONT PANEL ASSEMBLY

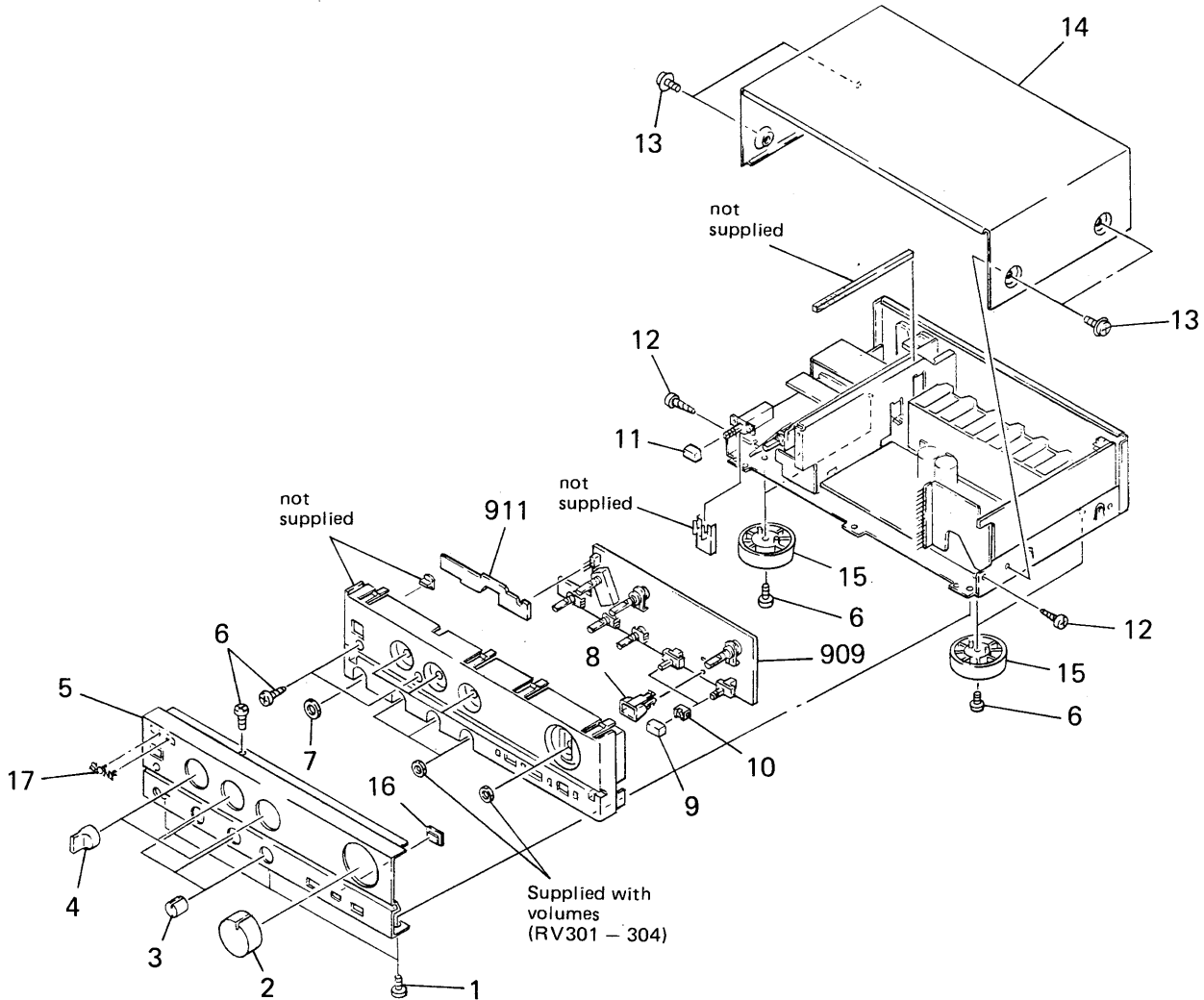

No.	Part No.	Description	Remarks	No.	Part No.	Description	Remarks
1	3-703-685-21	SCREW (+BV 3X8)		11	4-929-289-01	BUTTON	
2	4-929-288-11	(F110)...KNOB (VOL 47)		12	7-685-646-79	SCREW +BVTP 3X8 TYPE2 N-S	
	4-929-299-01	(F210)...KNOB (47)		13	3-704-366-01	SCREW (CASE) (M3X8)	
3	4-916-746-11	KNOB (DIA.21), ROUND		14	4-929-294-11	CASE	
4	4-916-729-01	KNOB (DIA.29)		15	X-3304-938-2	(EXCEPT F110:E)...FOOT ASSY	
5	4-929-293-01	(F110)...PANEL, FRONT			X-4885-950-1	(F110:E).....FOOT ASSY	
	4-929-293-11	(F210)...PANEL, FRONT		16	4-929-284-01	PLATE, INDICATION	
6	7-682-548-04	SCREW +BVTT 3X8 (S)		17	4-908-848-01	EMBLEM, SONY	
7	4-931-902-01	NUT (M12X1)		909	*1-630-937-11	(F210)...PC BOARD, FUNCTION	
8	*4-921-389-01	HOUSE			*1-630-941-11	(F110)...PC BOARD, FUNCTION	
9	4-908-875-01	KNOB, SQUARE		911	*1-630-939-11	(F210)...PC BOARD, LED	
10	4-864-307-00	RING			*1-630-943-11	(F110)...PC BOARD, LED	

(2) CHASSIS

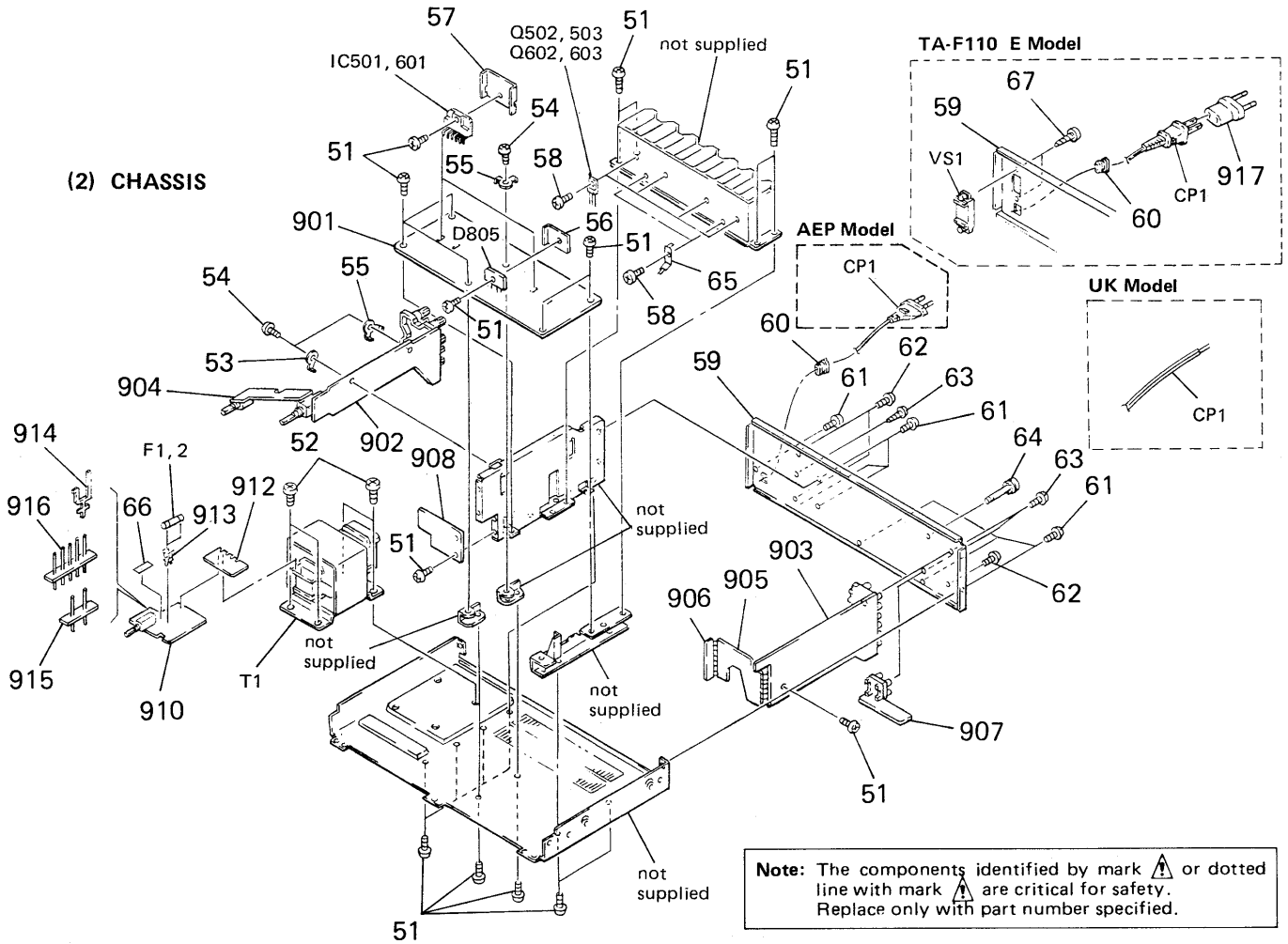

No.	Part No.	Description	Remarks	No.	Part No.	Description	Remarks
51	7-682-548-04	SCREW +BVTT 3X8 (S)		912	*1-630-940-11	(F210)...PC BOARD, TRANS	
52	7-682-560-04	SCREW +BVTT 4X6 (S)			*1-630-944-11	(F110)...PC BOARD, TRANS	
53	4-870-539-00	PLATE, GROUND		913	*1-533-213-31	HOLDER, FUSE	
54	3-703-685-21	SCREW (+BV 3X8)		914	Δ*1-535-771-11	(AEP,WG)...TERMINAL	
55	*3-346-266-12	PLATE, GROUND		915	Δ*1-535-139-00	(EXCEPT AEP,WG)...BASE POST 22MM (10MM PITCH) 2P	
56	*4-931-903-01	(F210)...HEAT SINK (D1)		916	Δ*1-535-142-00	(F110:E)...BASE POST 22MM(10MM PITCH) 5P	
57	*4-928-442-01	HEAT SINK (S)		917	Δ*1-526-565-00	(F110:E)...AC PLUG, ADAPTOR	
58	7-682-549-01	SCREW +B 3X10		CP1	Δ*1-555-750-00	(AEP,WG)...CORD, POWER	
59	*4-929-268-01	(F110:AEP)...PANEL, BACK		CP1	Δ*1-556-035-11	(UK)...CORD, POWER	
	*4-929-268-21	(F110:WG)...PANEL, BACK		CP1	Δ*1-558-943-11	(F110:E)...CORD, POWER	
	*4-929-268-31	(F110:UK)...PANEL, BACK		F1	Δ*1-532-078-00	(F110:E)...FUSE, TIME-LAG T1.0A	
	*4-929-268-41	(F110:E)...PANEL, BACK		F1	Δ*1-532-203-00	(F110:AEP,WG)...FUSE, TIME-LAG T2A	
	*4-929-269-01	(F210:AEP)...PANEL, BACK		F1	Δ*1-532-237-00	(F210:UK)...FUSE, TIME-LAG T3.15A	
	*4-929-269-21	(F210:WG)...PANEL, BACK		F1	Δ*1-532-259-00	(F110:UK)...FUSE, TIME-LAG T1.6A	
	*4-929-269-31	(F210:UK)...PANEL, BACK		F1	Δ*1-532-286-00	(F210:AEP,WG)...FUSE, TIME-LAG T2.5A	
60	*3-703-244-00	(EXCEPT F110:E)...BUSHING (2104), CORD		F2	Δ*1-532-078-00	(F110:E)...FUSE, TIME-LAG T1.0A	
	*3-703-571-00	(F110:E)...BUSHING (S)(4516), CORD		Q501	8-729-119-78	TRANSISTOR 2SC2785-HFE	
61	7-685-872-09	SCREW +BVTT 3X8 (S)		Q502	8-729-321-55	(F210)...TRANSISTOR 2SC4386-OPY-LF	
62	7-685-646-79	SCREW +BVTP 3X8 TYPE2 N-S		Q502	8-729-321-57	(F110)...TRANSISTOR 2SC4385-OPY-LF	
63	7-621-849-00	SCREW, TAPPING		Q503	8-729-321-56	(F210)...TRANSISTOR 2SC1671-OPY-LF	
64	3-706-165-00	SCREW		Q503	8-729-321-58	(F110)...TRANSISTOR 2SC1670-OPY-LF	
65	*4-929-285-01	BRACKET (TR)		Q601	8-729-119-78	TRANSISTOR 2SC2785-HFE	
66	*3-701-947-13	(F110:UK)...LABEL (T1.6A), FUSE		Q602	8-729-321-55	(F210)...TRANSISTOR 2SC4386-OPY-LF	
	*3-701-947-16	(F210:UK)...LABEL (T3.15A), FUSE		Q602	8-729-321-57	(F110)...TRANSISTOR 2SC4385-OPY-LF	
901	*A-4333-591-A	(F210:AEP)...MOUNTED PCB, AMP		Q603	8-729-321-56	(F210)...TRANSISTOR 2SA1671-OPY-LF	
	*A-4333-600-A	(F210:WG)...MOUNTED PCB, AMP		Q603	8-729-321-58	(F110)...TRANSISTOR 2SA1670-OPY-LF	
	*A-4333-604-A	(F210:UK)...MOUNTED PCB, AMP		T1	Δ*1-449-581-11	(F210:AEP,WG)...TRANSFORMER, POWER	
	*A-4333-609-A	(F110:AEP)...MOUNTED PCB, AMP		T1	Δ*1-449-582-11	(F210:UK)...TRANSFORMER, POWER	
	*A-4333-617-A	(F110:WG)...MOUNTED PCB, AMP		T1	Δ*1-449-583-11	(F110:AEP,WG)...TRANSFORMER, POWER	
	*A-4333-619-A	(F110:UK)...MOUNTED PCB, AMP		T1	Δ*1-449-584-11	(F110:UK)...TRANSFORMER, POWER	
	*A-4333-623-A	(F110:E)...MOUNTED PCB, AMP		T1	Δ*1-449-585-11	(F110:E)...TRANSFORMER, POWER	
902	*1-630-930-11	PC BOARD, SP SW		VS1	Δ*1-570-307-11	(F110:E)...SWITCH, VOLTEGE CHANGE (VOLTAGE SELECTOR)	
903	*1-630-931-11	PC BOARD, INPUT					
904	*1-630-932-11	PC BOARD, H.P					
905	*1-630-933-11	PC BOARD, CONECT (B)					
906	*1-630-934-11	PC BOARD, CONECT (C)					
907	*1-630-935-11	(F210)...PC BOARD, TAPE					
908	*1-630-936-11	PC BOARD, SHIELD					
910	*1-630-938-11	(F210)...PC BOARD, AC SW					
	*1-630-942-11	(F110)...PC BOARD, AC SW					

SECTION 7 ELECTRICAL PARTS LIST

NOTE:

- Due to standardization, replacements in the parts list may be different from the parts specified in the diagrams or the components used on the set.
- Items marked "★" are not stocked since they are seldom required for routine service. Some delay should be anticipated when ordering these items.
- If there are two or more same circuits in a set such as a stereophonic machine, only typical circuit parts may be indicated and capacitors and resistors in other same circuits may be omitted.

CAPACITORS:
MF: μ F, PF: μ MF.

RESISTORS
● All resistors are in ohms.
● F: nonflammable

COILS
● MMH: mH, UH: μ H

SEMICONDUCTORS
In each case, U: μ , for example:
UA...: μ A..., UPA...: μ PA...,
UPC...: μ PC, UPD...: μ PD...

The components identified by mark or dotted line with mark are critical for safety. Replace only with part number specified.

- Abbreviation
WG: West Germany Model

Ref.No.	Part No.	Description
901	*A-4333-591-A	(F210:AEP)...MOUNTED PCB, AMP
	*A-4333-600-A	(F210:WG)...MOUNTED PCB, AMP
	*A-4333-604-A	(F210:UK)...MOUNTED PCB, AMP
	*A-4333-609-A	(F110:AEP)...MOUNTED PCB, AMP
	*A-4333-617-A	(F110:WG)...MOUNTED PCB, AMP
	*A-4333-619-A	(F110:UK)...MOUNTED PCB, AMP
	*A-4333-623-A	(F110:E)...MOUNTED PCB, AMP
902	*1-630-930-11	PC BOARD, SP SW
903	*1-630-931-11	PC BOARD, INPUT
904	*1-630-932-11	PC BOARD, H.P
905	*1-630-933-11	PC BOARD, CONECT (B)
906	*1-630-934-11	PC BOARD, CONECT (C)
907	*1-630-935-11	(F210)...PC BOARD, TAPE
908	*1-630-936-11	PC BOARD, SHIELD
909	*1-630-937-11	(F210)...PC BOARD, FUNCTION
	*1-630-941-11	(F110)...PC BOARD, FUNCTION
910	*1-630-938-11	(F210)...PC BOARD, AC SW
	*1-630-942-11	(F110)...PC BOARD, AC SW
911	*1-630-939-11	(F210)...PC BOARD, LED
	*1-630-943-11	(F110)...PC BOARD, LED
912	*1-630-940-11	(F210)...PC BOARD, TRANS
	*1-630-944-11	(F110)...PC BOARD, TRANS
913	*1-533-213-31	HOLDER, FUSE
914	*1-535-771-11	(AEP, WG).....TERMINAL
915	*1-535-139-00	(EXCEPT AEP, WG)...BASE POST 22MM (10MM PITCH) 2P
916	*1-535-142-00	(F110:E)..BASE POST 22MM(10MM PITCH)5P
917	*1-526-565-00	(F110:E)...AC PLUG, ADAPTOR
C1	1-161-744-00	CERAMIC 0.01MF 400V
C101	1-162-286-31	(F210:WG)...CERAMIC 220PF 10% 50V
C102	1-162-286-31	(F210:WG)...CERAMIC 220PF 10% 50V
C103	1-162-286-31	(WG)...CERAMIC 220PF 10% 50V
C104	1-162-286-31	(WG)...CERAMIC 220PF 10% 50V
C105	1-162-286-31	(WG)...CERAMIC 220PF 10% 50V
C106	1-162-286-31	(WG)...CERAMIC 220PF 10% 50V
C107	1-162-286-31	(WG)...CERAMIC 220PF 10% 50V
C108	1-164-075-11	CERAMIC 150PF 10% 50V
C109	1-164-070-11	(WG)...CERAMIC 100PF 5% 50V
C110	1-126-233-11	ELECT 22MF 20% 50V
C111	1-123-333-00	(F210)...ELECT 100MF 20% 25V
C111	1-126-101-11	(F110)...ELECT 100MF 20% 16V
C112	1-164-075-11	CERAMIC 150PF 10% 50V
C113	1-130-339-00	(F210)...FILM 0.0056MF 5% 100V
C113	1-130-480-00	(F110)...MYLAR 0.0056MF 5% 50V

Ref.No.	Part No.	Description
C114	1-130-278-11	(F210)...FILM 0.0016MF 5% 100V
C114	1-130-473-00	(F110)...MYLAR 0.0015MF 5% 50V
C115	1-124-902-00	ELECT 0.47MF 20% 50V
C116	1-123-875-11	ELECT 10MF 20% 50V
C117	1-164-091-11	(WG)...CERAMIC 2200PF 10% 50V
C201	1-162-286-31	(F210:WG)...CERAMIC 220PF 10% 50V
C202	1-162-286-31	(F210:WG)...CERAMIC 220PF 10% 50V
C203	1-162-286-31	(WG)...CERAMIC 220PF 10% 50V
C204	1-162-286-31	(WG)...CERAMIC 220PF 10% 50V
C205	1-162-286-31	(WG)...CERAMIC 220PF 10% 50V
C206	1-162-286-31	(WG)...CERAMIC 220PF 10% 50V
C207	1-162-286-31	(WG)...CERAMIC 220PF 10% 50V
C208	1-164-075-11	CERAMIC 150PF 10% 50V
C209	1-164-070-11	(WG)...CERAMIC 100PF 5% 50V
C210	1-126-233-11	ELECT 22MF 20% 50V
C211	1-123-333-00	(F210)...ELECT 100MF 20% 25V
C211	1-126-101-11	(F110)...ELECT 100MF 20% 16V
C212	1-164-075-11	CERAMIC 150PF 10% 50V
C213	1-130-339-00	(F210)...FILM 0.0056MF 5% 100V
C213	1-130-480-00	(F110)...MYLAR 0.0056MF 5% 50V
C214	1-130-278-11	(F210)...FILM 0.0016MF 5% 100V
C214	1-130-473-00	(F110)...MYLAR 0.0015MF 5% 50V
C215	1-124-902-00	ELECT 0.47MF 20% 50V
C216	1-123-875-11	ELECT 10MF 20% 50V
C217	1-164-091-11	(WG)...CERAMIC 2200PF 10% 50V
C301	1-130-481-00	MYLAR 0.0068MF 5% 50V
C302	1-130-474-00	MYLAR 0.0018MF 5% 50V
C303	1-136-159-00	FILM 0.033MF 5% 50V
C304	1-130-479-00	MYLAR 0.0047MF 5% 50V
C305	1-136-157-00	(F210)...FILM 0.022MF 5% 50V
C306	1-164-084-11	(F210)...CERAMIC 820PF 10% 50V
C307	1-164-085-11	CERAMIC 1000PF 10% 50V
C401	1-130-481-00	MYLAR 0.0068MF 5% 50V
C402	1-130-474-00	MYLAR 0.0018MF 5% 50V
C403	1-136-159-00	FILM 0.033MF 5% 50V
C404	1-130-479-00	MYLAR 0.0047MF 5% 50V
C405	1-136-157-00	(F210)...FILM 0.022MF 5% 50V
C406	1-164-084-11	(F210)...CERAMIC 820PF 10% 50V
C407	1-164-085-11	CERAMIC 1000PF 10% 50V
C501	1-123-357-00	ELECT 22MF 20% 50V
C502	1-123-345-00	ELECT 100MF 20% 35V
C503	1-164-023-11	CERAMIC 15PF 5% 50V
C504	1-164-023-11	CERAMIC 15PF 5% 50V
C505	1-124-477-11	ELECT 47MF 20% 16V

Ref.No.	Part No.	Description	Ref.No.	Part No.	Description
C506	1-130-317-00	(F210)...FILM 0.068MF 5% 100V	C904	1-164-096-11	(WG)...CERAMIC 0.01MF 50V
C506	1-136-163-00	(F110)...FILM 0.068MF 5% 50V	C905	1-164-096-11	(WG)...CERAMIC 0.01MF 50V
C507	1-136-163-00	(EXCEPT F110:E)...FILM 0.068MF 5% 50V	C906	1-162-596-11	(WG)...CERAMIC 0.022MF 25V
C508	1-136-159-00	(F110:E)...FILM 0.033MF 5% 50V	CNJ101	1-565-320-11	JACK, PIN 6P (PHONO/TUNER/CD)
C509	1-136-163-00	(EXCEPT F110:E)...FILM 0.068MF 5% 50V	CNJ102	1-565-320-11	JACK, PIN 6P (VIDEO,AUX/TAPE,DAT OR TAPE 1)
C510	1-124-122-11	(F210)...ELECT 100MF 20% 50V	CNJ103	1-568-529-21	(F210)...JACK, PIN 4P (TAPE 2,DET)
C511	1-124-122-11	(F210)...ELECT 100MF 20% 50V	CNJ301	1-565-961-11	SOCKET, CONNECTOR 20P
C512	1-136-163-00	(WG)...FILM 0.068MF 5% 50V	CNJ302*1	1-565-835-11	SOCKET, CONNECTOR 3P
C601	1-123-357-00	ELECT 22MF 20% 50V	CNJ303*1	1-561-650-00	(F210)...SOCKET, CONNECTOR 5P
C602	1-123-345-00	ELECT 100MF 20% 35V	CNP301	1-565-419-11	PIN, CONNECTOR 10P
C603	1-164-023-11	CERAMIC 15PF 5% 50V	CNP302	1-565-419-11	PIN, CONNECTOR 10P
C604	1-164-023-11	CERAMIC 15PF 5% 50V	CNP303	1-506-906-11	(F210)...PIN, CONNECTOR 5P
C605	1-124-477-11	ELECT 47MF 20% 16V	CNP304	1-568-577-11	PIN, CONNECTOR (PC BOARD) 3P
C606	1-130-317-00	(F210)...FILM 0.068MF 5% 100V	CNP501*1	1-564-511-11	PLUG, CONNECTOR 8P
C606	1-136-163-00	(F110)...FILM 0.068MF 5% 50V	CP1	△,1-555-750-00	(AEP).....CORD, POWER
C607	1-136-163-00	(EXCEPT F110:E)...FILM 0.068MF 5% 50V	CP1	△,1-556-035-11	(UK).....CORD, POWER
C608	1-136-159-00	(F110:E)...FILM 0.033MF 5% 50V	CP1	△,1-558-943-11	(F110:E)...CORD, POWER
C609	1-136-163-00	(EXCEPT F110:E)...FILM 0.068MF 5% 50V	D501	8-719-815-85	DIODE 1S1585
C610	1-124-122-11	(F210)...ELECT 100MF 20% 50V	D502	8-719-815-85	DIODE 1S1585
C611	1-124-122-11	(F210)...ELECT 100MF 20% 50V	D601	8-719-815-85	DIODE 1S1585
C613	1-136-163-00	(WG)...FILM 0.068MF 5% 50V	D602	8-719-815-85	DIODE 1S1585
C612	1-136-163-00	(WG).....FILM 0.068MF 5% 50V	D701	8-719-200-77	DIODE 10E2N
C701	1-123-875-11	ELECT 10MF 20% 50V	D702	8-719-000-26	DIODE US1060M
C702	1-124-499-11	ELECT 1MF 20% 50V	D703	8-719-000-26	(EXCEPT F110:E)...DIODE US1060M
C703	1-126-176-11	ELECT 220MF 20% 6.3V	D801	8-719-200-77	(F210)...DIODE 10E2N
C705	1-123-875-11	ELECT 10MF 20% 50V	D802	8-719-200-77	(F210)...DIODE 10E2N
C706	1-124-443-00	ELECT 100MF 20% 10V	D803	8-719-200-77	(F210)...DIODE 10E2N
C801	1-125-536-11	(F210).....ELECT 10000MF 20% 50V	D804	8-719-200-77	(F210)...DIODE 10E2N
C801	1-126-224-11	(F110:UK,E)...ELECT 4700MF 20% 42V	D805	8-719-302-38	(F210:AEP,WG).....DIODE RBV-602-01
C801	1-126-256-11	(F110:AEP,WG)...ELECT 4700MF 20% 35V	D805	8-719-312-09	(EXCEPT F210:AEP,WG)...DIODE RBA-402
C802	1-125-536-11	(F210).....ELECT 10000MF 20% 50V	D901	8-719-304-14	DIODE SEL2510W
C802	1-126-224-11	(F110:UK,E)...ELECT 4700MF 20% 42V	D902	8-719-304-14	DIODE SEL2510W
C802	1-126-256-11	(F110:AEP,WG)...ELECT 4700MF 20% 35V	D903	8-719-303-00	DIODE SEL2510C
C803	1-126-104-11	ELECT 470MF 20% 35V	D904	8-719-303-00	DIODE SEL2510C
C804	1-126-104-11	ELECT 470MF 20% 35V	D905	8-719-303-00	DIODE SEL2510C
C805	1-124-499-11	ELECT 1MF 20% 50V	F1	△,1-532-078-00	(F110:E).....FUSE, TIME-LAG T1.0A
C806	1-126-103-11	ELECT 470MF 20% 16V	F1	△,1-532-285-00	(F110:AEP,WG)...FUSE, TIME-LAG T1.25A
C807	1-126-103-11	ELECT 470MF 20% 16V	F1	△,1-532-237-00	(210:UK).....FUSE, TIME-LAG T3.15A
C808	1-124-637-11	(EXCEPT F110:AEP,WG) ...ELECT 1000MF 20% 50V	F1	△,1-532-259-00	(F110:UK).....FUSE, TIME-LAG T1.6A
C808	1-126-105-11	(F110:AEP,WG)...ELECT 1000MF 20% 35V	F1	△,1-532-286-00	(F210:AEP,WG)...FUSE, TIME-LAG T2.5A
C809	1-124-637-11	(EXCEPT F110:AEP,WG) ...ELECT 1000MF 20% 50V	F2	△,1-532-078-00	(F110:E).....FUSE, TIME-LAG T1.0A
C809	1-126-105-11	(F110:AEP,WG)...ELECT 1000MF 20% 35V	IC101	8-759-601-02	IC M5218P
C810	1-126-233-11	(F210)...ELECT 22MF 20% 50V	IC501	8-759-109-06	IC UPC1298V
C811	1-126-233-11	(F210)...ELECT 22MF 20% 50V	IC601	8-759-109-06	IC UPC1298V
C812	1-123-357-00	(F210)...ELECT 22MF 20% 50V	IC701	8-759-111-68	IC UPC1237HA
C813	1-123-357-00	(F210)...ELECT 22MF 20% 50V	IC801	8-759-604-34	IC M5F7815
C814	1-136-163-00	(F110)...FILM 0.068MF 5% 50V	IC802	8-759-604-52	IC M5F7915
C815	1-130-798-00	(F210)...FILM 1MF 10% 250V	J901	1-507-863-51	JACK, LARGE TYPE (HEADPHONES)
C816	1-136-165-00	(F210)...FILM 0.1MF 5% 50V	L501	*1-420-872-00	COIL, AIR CORE
C817	1-162-596-11	(F110:WG)...CERAMIC 0.022MF 25V	L601	*1-420-872-00	COIL, AIR CORE
C817	1-130-973-00	(F210:WG)...FILM 0.022MF 10% 100V	Q501	8-729-119-78	TRANSISTOR 2SC2785-HFE
C818	1-136-163-00	(F110)...FILM 0.068MF 5% 50V	Q502	8-729-321-55	(F210)...TRANSISTOR 2SC4386-OPY-LF
C909	1-124-477-11	ELECT 47MF 20% 16V	Q502	8-729-321-57	(F110)...TRANSISTOR 2SC4385-OPY-LF
C901	1-164-096-11	(WG)...CERAMIC 0.01MF 50V			
C902	1-164-096-11	(WG)...CERAMIC 0.01MF 50V			
C903	1-162-596-11	(WG)...CERAMIC 0.022MF 25V			

Note: The components identified by mark Δ or dotted line with mark Δ are critical for safety. Replace only with part number specified.

Ref.No.	Part No.	Description
Q503	8-729-321-56	(F210)...TRANSISTOR 2SA1671-OPY-LF
Q503	8-729-321-58	(F110)...TRANSISTOR 2SA1670-OPY-LF
Q504	8-729-108-06	TRANSISTOR 2SC1841
Q601	8-729-119-78	TRANSISTOR 2SC2785-HFE
Q602	8-729-321-55	(F210)...TRANSISTOR 2SC4386-OPY-LF
Q602	8-729-321-57	(F110)...TRANSISTOR 2SC4385-OPY-LF
Q603	8-729-321-56	(F210)...TRANSISTOR 2SA1671-OPY-LF
Q603	8-729-321-58	(F110)...TRANSISTOR 2SA1670-OPY-LF
Q604	8-729-108-06	TRANSISTOR 2SC1841
Q701	8-729-900-63	TRANSISTOR DTA124ES
Q704	8-729-245-82	TRANSISTOR 2SC2458-Y
Q801	8-729-177-42	(F210)...TRANSISTOR 2SD774-3
Q802	8-729-140-97	(F210)...TRANSISTOR 2SB734-34
R11	1-249-405-11	CARBON 100 5% 1/4W
R12	1-249-405-11	CARBON 100 5% 1/4W
R13	1-249-405-11	CARBON 100 5% 1/4W
R101	1-247-713-11	(F210).....CARBON 1K 5% 1/4W
R102	1-247-708-11	(F210:WG)...CARBON 470 5% 1/4W
R103	1-247-713-11	CARBON 1K 5% 1/4W
R104	1-247-708-11	(WG).....CARBON 470 5% 1/4W
R105	1-247-708-11	(WG).....CARBON 470 5% 1/4W
R106	1-247-708-11	(WG).....CARBON 470 5% 1/4W
R107	1-247-708-11	(WG).....CARBON 470 5% 1/4W
R108	1-247-714-11	CARBON 1.2K 5% 1/4W
R109	1-249-469-11	CARBON 100K 5% 1/4W
R110	1-247-714-11	(WG).....CARBON 1.2K 5% 1/4W
R111	1-249-469-11	CARBON 100K 5% 1/4W
R112	1-247-712-11	CARBON 820 5% 1/4W
R113	1-246-539-00	(F110)...CARBON 560K 5% 1/4W
R113	1-249-618-11	(F210)...CARBON 560K 5% 1/4W
R114	1-249-465-11	CARBON 47K 5% 1/4W
R115	1-249-469-11	CARBON 100K 5% 1/4W
R116	1-247-704-11	CARBON 220 5% 1/4W
R117	1-247-903-00	(F210)...CARBON 1M 5% 1/4W
R118	1-247-903-00	CARBON 1M 5% 1/4W
R119	1-247-903-00	CARBON 1M 5% 1/4W
R120	1-247-903-00	CARBON 1M 5% 1/4W
R121	1-247-903-00	CARBON 1M 5% 1/4W
R201	1-247-713-11	(F210)...CARBON 1K 5% 1/4W
R202	1-247-708-11	(F210:WG)...CARBON 470 5% 1/4W
R203	1-247-713-11	CARBON 1K 5% 1/4W
R204	1-247-708-11	(WG).....CARBON 470 5% 1/4W
R205	1-247-708-11	(WG)...CARBON 470 5% 1/4W
R206	1-247-708-11	(WG)...CARBON 470 5% 1/4W
R207	1-247-708-11	(WG)...CARBON 470 5% 1/4W
R208	1-247-714-11	CARBON 1.2K 5% 1/4W
R209	1-249-469-11	CARBON 100K 5% 1/4W
R210	1-247-714-11	(WG)...CARBON 1.2K 5% 1/4W
R211	1-249-469-11	CARBON 100K 5% 1/4W
R212	1-247-712-11	CARBON 820 5% 1/4W
R213	1-246-539-00	(F110)...CARBON 560K 5% 1/4W
R213	1-249-618-11	(F210)...CARBON 560K 5% 1/4W
R214	1-249-465-11	CARBON 47K 5% 1/4W
R215	1-249-469-11	CARBON 100K 5% 1/4W
R216	1-247-704-11	CARBON 220 5% 1/4W

Ref.No.	Part No.	Description
R217	1-247-903-00	(F210)...CARBON 1M 5% 1/4W
R218	1-247-903-00	CARBON 1M 5% 1/4W
R219	1-247-903-00	CARBON 1M 5% 1/4W
R220	1-247-903-00	CARBON 1M 5% 1/4W
R221	1-247-903-00	CARBON 1M 5% 1/4W
R301	1-247-700-11	CARBON 100 5% 1/4W
R302	1-246-545-00	CARBON 1M 5% 1/4W
R303	1-247-717-11	CARBON 2.2K 5% 1/4W
R304	1-247-722-11	CARBON 5.6K 5% 1/4W
R305	1-246-545-00	CARBON 1M 5% 1/4W
R307	1-247-152-00	CARBON 7.5K 5% 1/4W
R308	1-247-170-00	CARBON 43K 5% 1/4W
R309	1-249-464-11	CARBON 39K 5% 1/4W
R310	1-249-465-11	CARBON 47K 5% 1/4W
R311	1-249-433-11	(F210)...CARBON 22K 5% 1/4W
R312	1-249-441-11	(F210)...CARBON 100K 5% 1/4W
R313	1-247-903-00	(F210)...CARBON 1M 5% 1/4W
R314	1-249-429-11	(F210)...CARBON 10K 5% 1/4W
R401	1-247-700-11	CARBON 100 5% 1/4W
R402	1-246-545-00	CARBON 1M 5% 1/4W
R403	1-247-717-11	CARBON 2.2K 5% 1/4W
R404	1-247-722-11	CARBON 5.6K 5% 1/4W
R405	1-246-545-00	CARBON 1M 5% 1/4W
R407	1-247-152-00	CARBON 7.5K 5% 1/4W
R408	1-247-170-00	CARBON 43K 5% 1/4W
R409	1-249-464-11	CARBON 39K 5% 1/4W
R410	1-249-465-11	CARBON 47K 5% 1/4W
R411	1-249-433-11	(F210)...CARBON 22K 5% 1/4W
R412	1-249-441-11	(F210)...CARBON 100K 5% 1/4W
R413	1-247-903-00	(F210)...CARBON 1M 5% 1/4W
R414	1-249-429-11	(F210)...CARBON 10K 5% 1/4W
R501	1-247-713-11	CARBON 1K 5% 1/4W
R502	1-249-469-11	CARBON 100K 5% 1/4W
R503	1-247-711-11	(F210:UK)....CARBON 680 5% 1/4W
R503	1-247-712-11	(F110:UK,E/F210:AEP,WG).....CARBON 820 5% 1/4W
R503	1-247-714-11	(F110:AEP,WG)...CARBON 1.2K 5% 1/4W
R504	1-249-496-11	(F110)...CARBON 100K 5% 1/2W
R504	1-249-721-11	(F210)...CARBON 100K 5% 1/2W
R505	1-249-460-11	CARBON 15K 5% 1/4W
R506	1-249-423-11	CARBON 3.3K 5% 1/4W
R507	1-249-419-11	CARBON 1.5K 5% 1/4W
R508	△ 1-247-688-11	CARBON 10 5% 1/4W F
R509	△ 1-216-361-00	METAL OXIDE 0.22 5% 2W F
R510	△ 1-216-361-00	(F210)...METAL OXIDE 0.22 5% 2W F
R511	△ 1-247-688-11	CARBON 10 5% 1/4W F
R512	△ 1-247-704-11	CARBON 220 5% 1/4W F
R513	1-247-719-11	(F110:AEP,WG)...CARBON 3.3K 5% 1/4W
R513	1-247-724-11	(F110:UK,E)....CARBON 8.2K 5% 1/4W
R513	1-247-725-11	(F210:AEP,WG)...CARBON 10K 5% 1/4W
R513	1-249-464-11	(F210:UK).....CARBON 39K 5% 1/4W
R514	1-247-727-11	CARBON 10 5% 1/2W
R515	1-249-465-11	CARBON 47K 5% 1/4W
R516	1-247-727-11	CARBON 10 5% 1/2W
R521	△ 1-216-361-00	METAL OXIDE 0.22 5% 2W F
R522	△ 1-216-361-00	(F210)...METAL OXIDE 0.22 5% 2W F
R601	1-247-713-11	CARBON 1K 5% 1/4W
R602	1-249-469-11	CARBON 100K 5% 1/4W

Note: The components identified by mark Δ or dotted line with mark Δ are critical for safety. Replace only with part number specified.

Ref.No.	Part No.	Description
R603	1-247-711-11	(F210:UK)...CARBON 680 5% 1/4W
R603	1-247-712-11	(F110:UK,E/F210:AEP,WG) ...CARBON 820 5% 1/4W
R603	1-247-714-11	(F110:AEP,WG)...CARBON 1.2K 5% 1/4W
R604	1-249-496-11	(F110)...CARBON 100K 5% 1/2W
R604	1-249-721-11	(F210)...CARBON 100K 5% 1/2W
R605	1-249-460-11	CARBON 15K 5% 1/4W
R606	1-249-423-11	CARBON 3.3K 5% 1/4W
R607	1-249-419-11	CARBON 1.5K 5% 1/4W
R608	△ 1-247-688-11	CARBON 10 5% 1/4W F
R609	△ 1-216-361-00	METAL OXIDE 0.22 5% 2W F
R610	△ 1-216-361-00	(F210)...METAL OXIDE 0.22 5% 2W F
R611	△ 1-247-688-11	CARBON 10 5% 1/4W F
R612	△ 1-247-704-11	CARBON 220 5% 1/4W F
R613	1-247-719-11	(F110:AEP,WG)...CARBON 3.3K 5% 1/4W
R613	1-247-724-11	(F110:UK,E)...CARBON 8.2K 5% 1/4W
R613	1-247-725-11	(F210:AEP,WG)...CARBON 10K 5% 1/4W
R613	1-249-464-11	(F210:UK)...CARBON 39K 5% 1/4W
R614	1-247-727-11	CARBON 10 5% 1/2W
R615	1-249-466-11	CARBON 56K 5% 1/4W
R616	1-247-727-11	CARBON 10 5% 1/2W
R621	△ 1-216-361-00	METAL OXIDE 0.22 5% 2W F
R622	△ 1-216-361-00	(F210)...METAL OXIDE 0.22 5% 2W F
R701	1-247-723-11	(F110:AEP,WG)...CARBON 6.8K 5% 1/4W
R701	1-247-724-11	(F110:UK,E)...CARBON 8.2K 5% 1/4W
R701	1-247-725-11	(F210:AEP,WG)...CARBON 10K 5% 1/4W
R701	1-249-460-11	(F210:UK)...CARBON 15K 5% 1/4W
R702	1-249-437-11	CARBON 47K 5% 1/4W
R703	1-249-441-11	CARBON 100K 5% 1/4W
R704	1-249-437-11	CARBON 47K 5% 1/4W
R705	△ 1-215-890-11	(F110:E/F210:AEP) ...METAL OXIDE 470 5% 2W F
R705	△ 1-215-891-11	(F210:UK)...METAL OXIDE 680 5% 2W F
R705	△ 1-216-428-00	(F110:AEP,WG)...METAL OXIDE 180 5% 1W F
R705	△ 1-216-430-11	(F110:UK)...METAL OXIDE 390 5% 1W F
R706	1-247-725-11	(F110:AEP,WG)...CARBON 10K 5% 1/4W
R706	1-249-459-11	(F110:UK,E/F210:AEP,WG) ...CARBON 12K 5% 1/4W
R706	1-249-460-11	(F210:UK)...CARBON 15K 5% 1/4W
R708	1-249-419-11	CARBON 1.5K 5% 1/4W
R801	△ 1-215-911-11	(F110:AEP,WG)...METAL OXIDE 100 5% 3W F
R801	△ 1-215-914-11	(F110:E/F210:AEP,WG) ...METAL OXIDE 330 5% 3W F
R801	△ 1-216-477-11	(F110:UK)...METAL OXIDE 270 5% 3W F
R801	△ 1-216-478-11	(F210:UK)...METAL OXIDE 390 5% 3W F
R802	△ 1-215-917-11	(F110:UK)...METAL OXIDE 1K 5% 3W F
R802	△ 1-216-478-11	(F110:AEP,WG)...METAL OXIDE 390 5% 3W F
R802	△ 1-216-481-11	(F110:E/F210:AEP,WG) ...METAL OXIDE 1.2K 5% 3W F
R802	△ 1-216-482-11	(F210:UK)...METAL OXIDE 1.8K 5% 3W F
R803	△ 1-249-447-11	(F110)...CARBON 1 5% 1/4W F
R803	△ 1-249-451-11	(F210)...CARBON 2.2 5% 1/4W F
R804	△ 1-249-447-11	(F110)...CARBON 1 5% 1/4W F
R804	△ 1-249-451-11	(F210)...CARBON 2.2 5% 1/4W F
R805	△ 1-247-713-11	(F210)...CARBON 1K 5% 1/4W F
R805	△ 1-249-381-11	(F110)...CARBON 1 5% 1/4W F
R806	△ 1-247-715-11	(F210)...CARBON 1.5K 5% 1/4W F
R806	△ 1-249-381-11	(F110)...CARBON 1 5% 1/4W F

Ref.No.	Part No.	Description
R807	△ 1-247-695-11	(F210:AEP,WG)...CARBON 39 5% 1/4W F
R807	△ 1-247-697-00	(F210:UK)...CARBON 56 5% 1/4W F
R901	1-247-743-11	(AEP,WG)...CARBON 220 5% 1/2W
R901	1-247-744-11	(F210:UK)...CARBON 270 5% 1/2W
R901	1-247-745-11	(F110:UK,E)...CARBON 330 5% 1/2W
R902	1-247-743-11	(AEP,WG)...CARBON 220 5% 1/2W
R902	1-247-744-11	(F210:UK)...CARBON 270 5% 1/2W
R902	1-247-745-11	(F110:UK,E)...CARBON 330 5% 1/2W
R903	1-247-727-11	(WG)...CARBON 10 5% 1/2W
R904	1-247-727-11	(WG)...CARBON 10 5% 1/2W
R905	1-247-727-11	(WG)...CARBON 10 5% 1/2W
R906	1-247-727-11	(WG)...CARBON 10 5% 1/2W
R907	1-249-412-11	CARBON 390 5% 1/4W
R908	1-249-413-11	CARBON 470 5% 1/4W
R909	1-249-413-11	CARBON 470 5% 1/4W
R911	1-247-743-11	(AEP,WG)...CARBON 220 5% 1/2W
R911	1-247-744-11	(F210:UK)...CARBON 270 5% 1/2W
R911	1-247-745-11	(F110:UK,E)...CARBON 330 5% 1/2W
R912	1-247-743-11	(AEP,WG)...CARBON 220 5% 1/2W
R912	1-247-744-11	(F210:UK)...CARBON 270 5% 1/2W
R912	1-247-745-11	(F110:UK,E)...CARBON 330 5% 1/2W
RV301	1-238-513-11	RES, VAR, CARBON 150K/150K (BALANCE)
RV302	1-238-514-11	RES, VAR 250K/250K (TONE:TREBLE)
RV303	1-238-515-11	RES, VAR, CARBON 520K/520K (TONE:BASS)
RV304	1-238-512-11	RES, VAR, CARBON 120K/120K (VOLUME)
RV501	1-237-455-11	RES, ADJ, CARBON 500
RV601	1-237-455-11	RES, ADJ, CARBON 500
RY701	1-515-501-00	(F210)...RELAY
RY701	1-515-533-11	(F110)...RELAY
S1	△ 1-554-920-21	SWITCH, PUSH (AC POWER)(1 KEY)(POWER)
S301	1-571-871-11	(F210)...SWITCH, ROTARY SLIDDE (INPUT SELECTOR)
S302	1-571-871-11	(F210)...SWITCH, ROTARY SLIDDE (REC OUT SELECTOR)
S302	1-571-873-11	(F110)...SWITCH, ROTARY SLIDE (INPUT SELECTOR)
S303	1-571-828-11	SWITCH, PUSH (1 KEY)(SOURCE DIRECT)
S304	1-571-828-11	(F210)...SWITCH, PUSH(1 KEY)(LOUDNESS)
S304	1-571-872-11	(F110)...SWITCH, PUSH(1KEY) (TAPE/DAT MONITER)
S901	1-571-870-11	SWITCH, ROTARY SLIDDE (SPEAKERS)
T1	△ 1-449-581-11	(F210:AEP,WG)...TRANSFORMER, POWER
T1	△ 1-449-582-11	(F210:UK)...TRANSFORMER, POWER
T1	△ 1-449-583-11	(F110:AEP,WG)...TRANSFORMER, POWER
T1	△ 1-449-584-11	(F110:UK)...TRANSFORMER, POWER
T1	△ 1-449-585-11	(F110:E)...TRANSFORMER, POWER
TM901	1-537-227-11	(AEP)...TERMINAL BOARD (SP) (SPEAKER A/B)
TM901	1-537-228-11	(WG,UK,F110:E)...TERMINAL BOARD (SP) (SPEAKER A/B)
TP1	*1-535-115-00	TERMINAL
TP2	*1-535-115-00	TERMINAL
VS1	△ 1-570-307-11	(F110:E)...SWITCH, VOLTEGE CHANGE (VOLTAGE SELECTOR)

Note: The components identified by mark △ or dotted line with mark △ are critical for safety. Replace only with part number specified.

ACCESSORY & PACKING MATERIAL

- 3-750-399-11 (EXCEPT WG)...MANUAL, INSTRUCTION
(ENGLISH,FRENCH,SPANISH,PORTUGUESE)
- 3-750-399-41 (WG)...MANUAL, INSTRUCTION
(GERMAN,DUTCH,SWEDISH,ITALIAN)
- 3-750-399-51 (WG)...MANUAL, INSTRUCTION (GERMAN)
- *4-929-258-01 (F110)...INDIVIDUAL CARTON
- *4-929-259-01 (F210)...INDIVIDUAL CARTON
- *4-929-260-01 CUSHION