

TA-F161/F261R

SERVICE MANUAL

AEP Model
UK Model
 TA-F161/F261R
E Model
 TA-F261R



Photo: TA-F261R

SPECIFICATIONS

Amplifier

Continuous RMS power output (both channels driven simultaneously)

		TA-F261R	TA-F161
DIN, 1 kHz	4 ohms	50 W + 50 W	—
	8 ohms	40 W + 40 W	40 W + 40 W

Input

Input jack	Jack type	Sensitivity	Impedance
PHONO (MM)	Phono	2.5 mV	50 kilohms
TUNER, CD, TAPE 1/DAT TAPE 2/MD	Phono	200 mV	50 kilohms

S/N

PHONO (MM)	80 dB
TUNER, CD, TAPE 1/DAT TAPE 2/MD	105 dB

Output

Output jack	Jack type	Voltage/impedance
REC OUT	Phono jack	Voltage 200 mV Impedance 1 kohm
PHONES	Stereo phone jack	Accepts low and high impedance headphones

Tone controls

	Response
BASS	±8 dB (100 Hz)
TREBLE	±8 dB (10 kHz)

Frequency response PHONO: RIAA equalization curve
 ±0.5 dB
 TUNER, CD, TAPE 1/DAT, TAPE 2/MD:
 10 Hz – 100 kHz ± 3 dB
 Residual noise Less than 170 μ V (network A)

General

System Preamplifier: Low-noise, equalizer amplifier
 Power amplifier: Pure-complementary SEPP OCL power amplifier
 Power requirements AEP, German, UK model:
 220 V – 230 V AC, 50/60 Hz
 E model: 120 V, 220 V or
 240 V AC adjustable, 50/60 Hz
 Power consumption TA-F261R: 120 W
 TA-F161: 100 W
 Dimensions Approx. 430 × 115 × 310 mm (w/h/d)
 (17 × 4 $\frac{1}{2}$ × 12 $\frac{1}{4}$ inches)
 Mass TA-F261R: Approx. 4.5 kg (9 lb 15 oz)
 TA-F161: Approx. 4.4 kg (9 lb 11 oz)
 Supplied accessories (TA-F261R only) Remote commander RM-S312 (1)
 Sony SUM-3 (NS) batteries (2)

The above values are measured at 230 V AC. (Models for continental European countries and U.K.)

Design and specifications are subject to change without notice.



INTEGRATED STEREO AMPLIFIER
SONY®

TABLE OF CONTENTS

<u>Section</u>	<u>Title</u>	<u>Page</u>
Specifications		1
Model Identification		2
1. GENERAL		
Location of Controls		3
2. DIAGRAMS		
2-1. IC Pin Function		4
2-2. Circuit Boards Location		5
2-3. Printed Wiring Boards		6
2-4. Schematic Diagram		9
3. EXPLODED VIEWS		12
4. ELECTRICAL PARTS LIST		14

MODEL IDENTIFICATION

– Model Number Portion –
Carved on Back Panel

AEP, German, UK model: TA-F161
AEP, German, UK, E model: TA-F261R

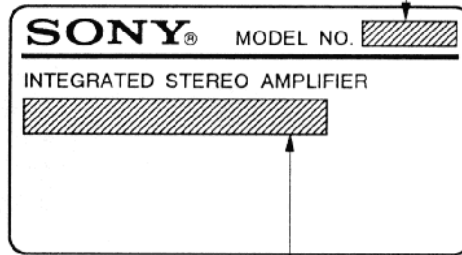



TA-F161

AEP, German model: AC 220 – 230 V ~50/60 Hz 100 W
UK model: AC 220 – 230 V ~50/60 Hz

TA-F261R

AEP, German model: AC 220 – 230 V ~50/60 Hz 120 W
UK model: AC 220 – 230 V ~50/60 Hz
E Model: AC 120/220/240 V ~50/60 Hz 120 W

SAFETY-RELATED COMPONENT WARNING!!

COMPONENTS IDENTIFIED BY MARK  OR DOTTED LINE WITH MARK  ON THE SCHEMATIC DIAGRAMS AND IN THE PARTS LIST ARE CRITICAL TO SAFE OPERATION. REPLACE THESE COMPONENTS WITH SONY PARTS WHOSE PART NUMBERS APPEAR AS SHOWN IN THIS MANUAL OR IN SUPPLEMENTS PUBLISHED BY SONY.

SECTION 1 GENERAL

This section is extracted from instruction manual.

LOCATION OF CONTROLS

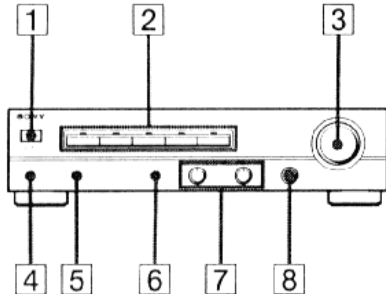

This section describes about each name of this amplifier and remote commander.

Front Panel

- 1 POWER switch
- 2 Function selectors and indicators
- 3 VOLUME control
Adjusts the sound level.
- 4 PHONES jack
- 5 Remote control sensor (TA-F261R only)
- 6 LOUDNESS button
- 7 TONE (BASS/TREBLE) controls
- 8 BALANCE control

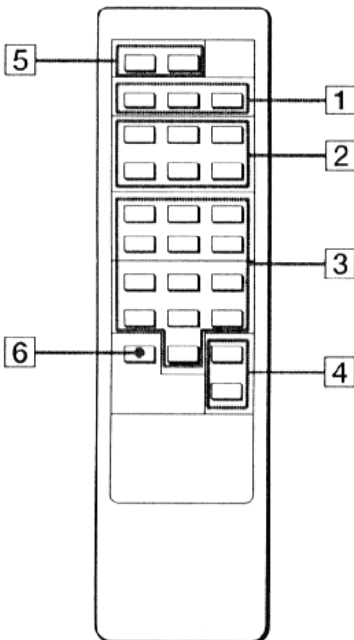

Remote Commander (TA-F261R only)

Supplied remote commander can control Sony equipment such as tuner, CD players, and tape decks.

- 1 TUNER operation buttons
TUNER: Select the TUNER mode.
PRESET +/- buttons: Select the preset station.
- 2 CD operation buttons
◀▶/▶▶: Automatic music sensor.
D. (Disc) SKIP: Disc skip (for CD player equipped with a multi-disc changer)
▶▶: The amplifier enters the CD mode and the CD player starts playback automatically.
■: Stop.
||: Pause.
- 3 TAPE 2 DECK A/DECK B operation buttons
◀▶/▶▶: Fast winding.
■: Stop.
◀: The amplifier enters the TAPE 2 mode and the tape deck starts reverse playback automatically.
▶: The amplifier enters the TAPE 2 mode and the tape deck starts forward playback automatically.

- + ▶: Start recording
- + ◀: Start recording in the reverse direction
- ||: Pause. (Only for DECK B)

- 4 VOL (Volume) +/- buttons
- 5 PHONO operation buttons
START: Pressing START automatically selects the PHONO mode on the amplifier and starts playback of the turntable system.
STOP: Stops playback of the turntable system.
- 6 DAT/TAPE 1 button
Selects the DAT or TAPE 1 mode.

SECTION 2 DIAGRAMS

2-1. IC PIN FUNCTION

• IC801 Function Controller (M50761-291P)

Micro Processor M50761-291P is used for control the volume up/down, function select and power on/standby by SIRCS code signal input and power on/standby key code signal input.

Pin No.	Pin Name	I/O	Description						
1	PHONO	O	Function select output. (one-shot output) (L : PHONO)						
2	CD	O	Function select output. (one-shot output) (L : CD)						
3	AUX	O	Function select output. (one-shot output) (L : AUX) To ground.						
4	CN VSS	—	Ground						
5	VSS	—	Ground						
6	TAPE1	O	Function select output. (one-shot output) (L : TAPE1)						
7	TUNER	O	Function select output. (one-shot output) (L : TUNER)						
8	POWER	O	Power supply ON/OFF relay (RY1).control output. (L : POWER ON, H : POWER OFF) To ground.						
9	TAPE2	O	Function select output. (one-shot output) (L : TAPE2)						
10	POWER IN	I	POWER ON/STANDBY key switch input. To ground.						
11	MODE	I	Mode select input. This model is used "L" level only. To ground. <table border="1" style="margin-left: auto; margin-right: auto;"> <thead> <tr> <th colspan="2">POWER ON/OFF mode</th> </tr> </thead> <tbody> <tr> <td>H</td> <td>USED</td> </tr> <tr> <td>L</td> <td>NOT USED</td> </tr> </tbody> </table>	POWER ON/OFF mode		H	USED	L	NOT USED
POWER ON/OFF mode									
H	USED								
L	NOT USED								
12	NC	—	Ground						
13	RESET	I	Reset signal input.						
14	X OUT	O	Ceramic vibrator connection terminal. (400Hz)						
15	X IN	I	Ceramic vibrator connection terminal. (400Hz)						
16	NC	—	Ground						
17	SIRCS	I	SIRCS code signal input. (serial input)						
18	VOL UP	O	Volume motor up control output. (contineous output)						
19	VOL DOWN	O	Volume motor down control output. (contineous output)						
20	VDD	—	+5V power supply.						

2-2. CIRCUIT BOARDS LOCATION

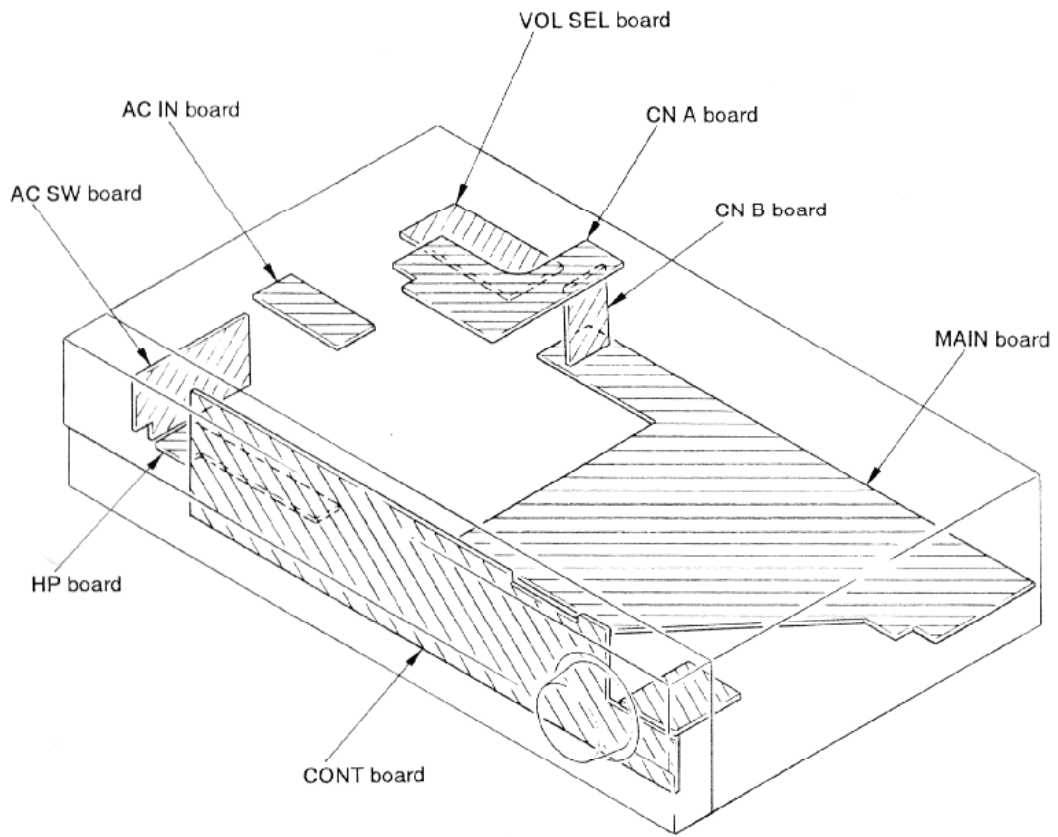

TA-F161/F261R

2-3. PRINTED WIRING BOARDS

• Semiconductor Location

Ref. No.	Location
D301	H-8
D302	H-8
D351	I-8
D352	I-8
D601	G-7
D701	H-4
D702	I-4
D703	I-4
D704	I-6
D705	H-5
D706	I-5
D707	I-4
D801	A-3
D802	C-1
D803	C-3
D804	C-4
D805	C-6
D806	C-7
D807	C-3
D808	C-4
D809	C-6
D810	C-8
D811	C-4
D812	C-5
D813	C-7
D814	C-8
D815	A-13
D816	C-8
D901	G-18
D902	F-7
D903	F-6
D904	E-12
D905	E-12
D906	E-12
D907	E-12
D909	H-4
IC101	G-2
IC102	F-5
IC103	G-4
IC301	I-10
IC601	I-8
IC801	B-4
IC802	A-1
IC803	A-14
IC901	K-8
Q101	I-5
Q151	I-5
Q301	H-8
Q351	H-8
Q701	H-4
Q702	I-4
Q703	I-5
Q704	I-4
Q705	J-5
Q706	J-5
Q707	H-3
Q708	H-4
Q709	H-6
Q710	H-6
Q801	A-2
Q802	A-2
Q901	F-6
Q902	F-6
Q903	H-5

Note:

- ○ — : parts extracted from the component side.
- ■ : Pattern from the side which enables seeing.

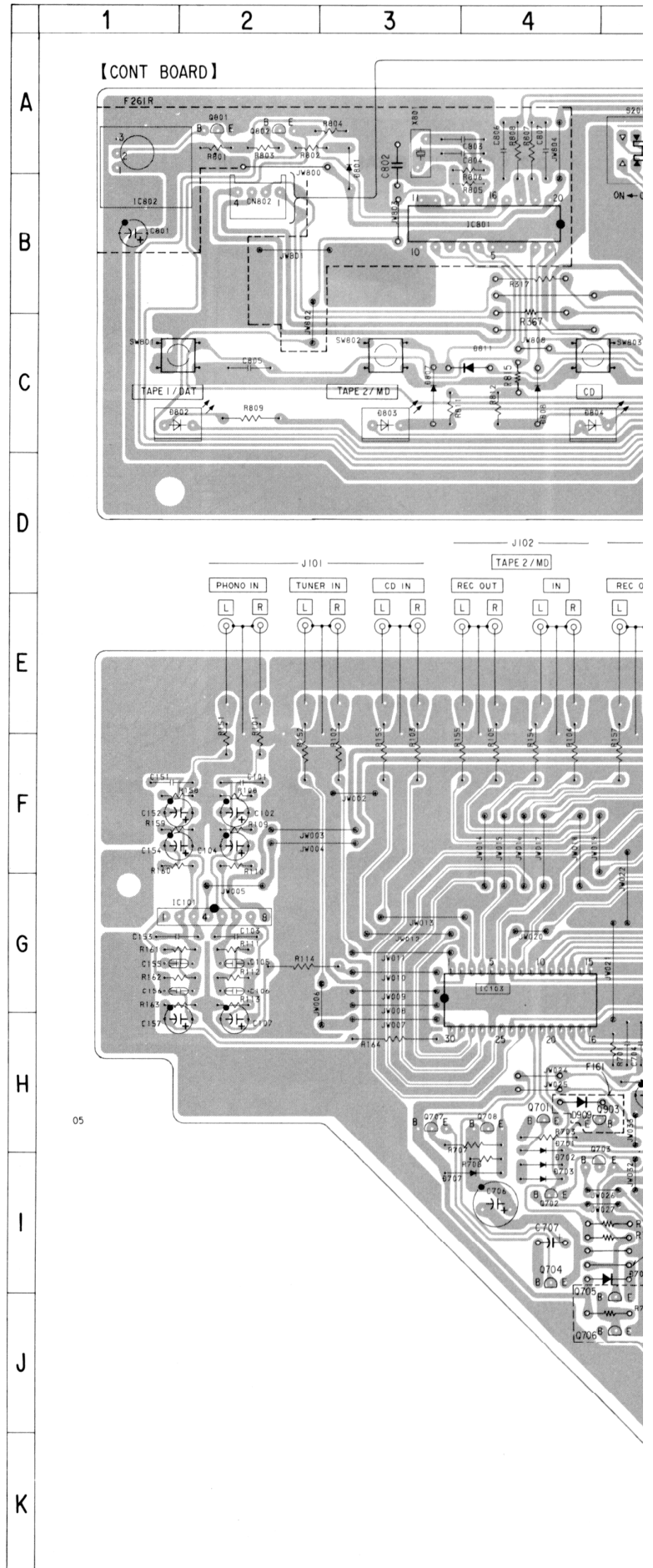

5

6

7

8

9

10

11

12

13

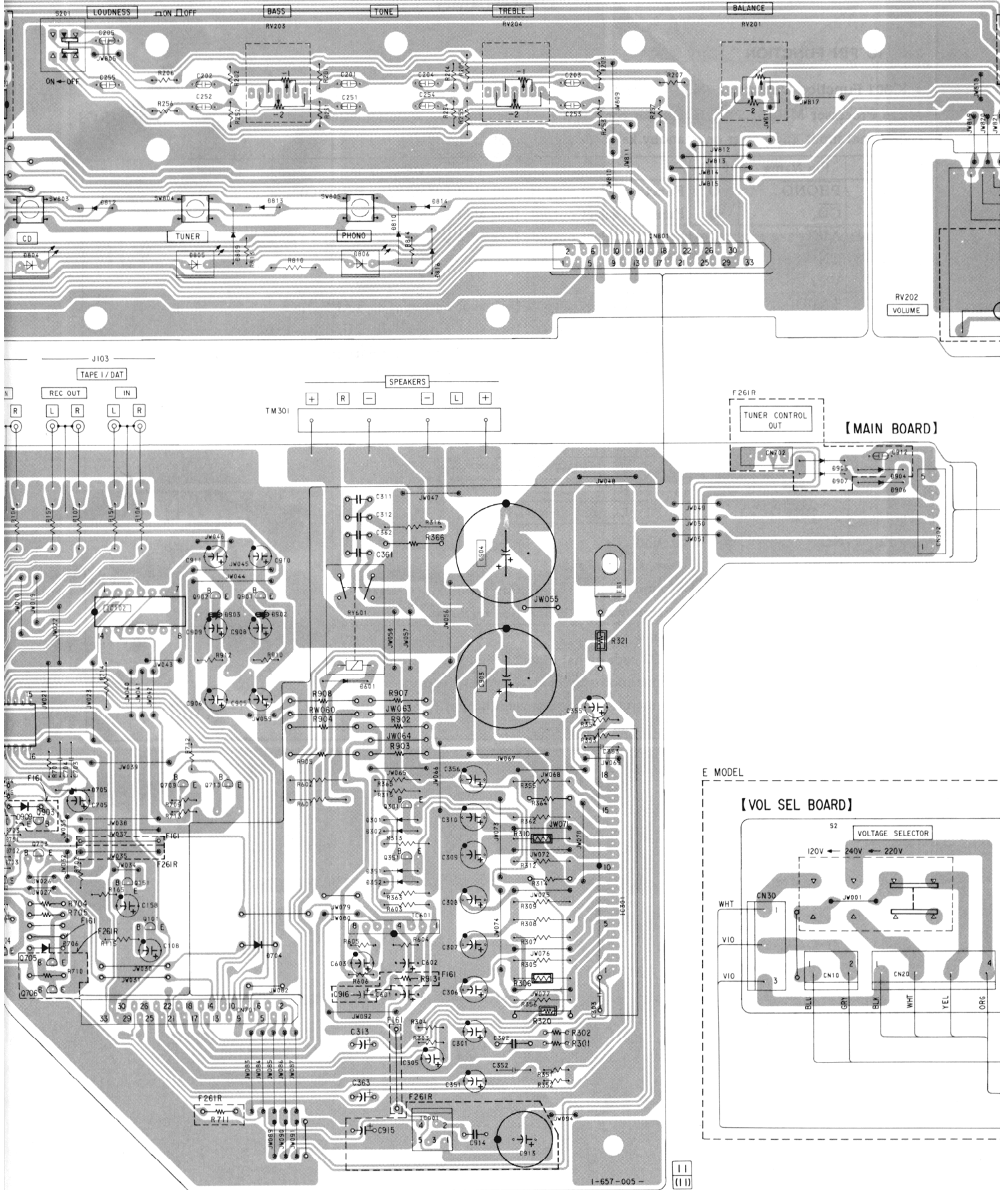

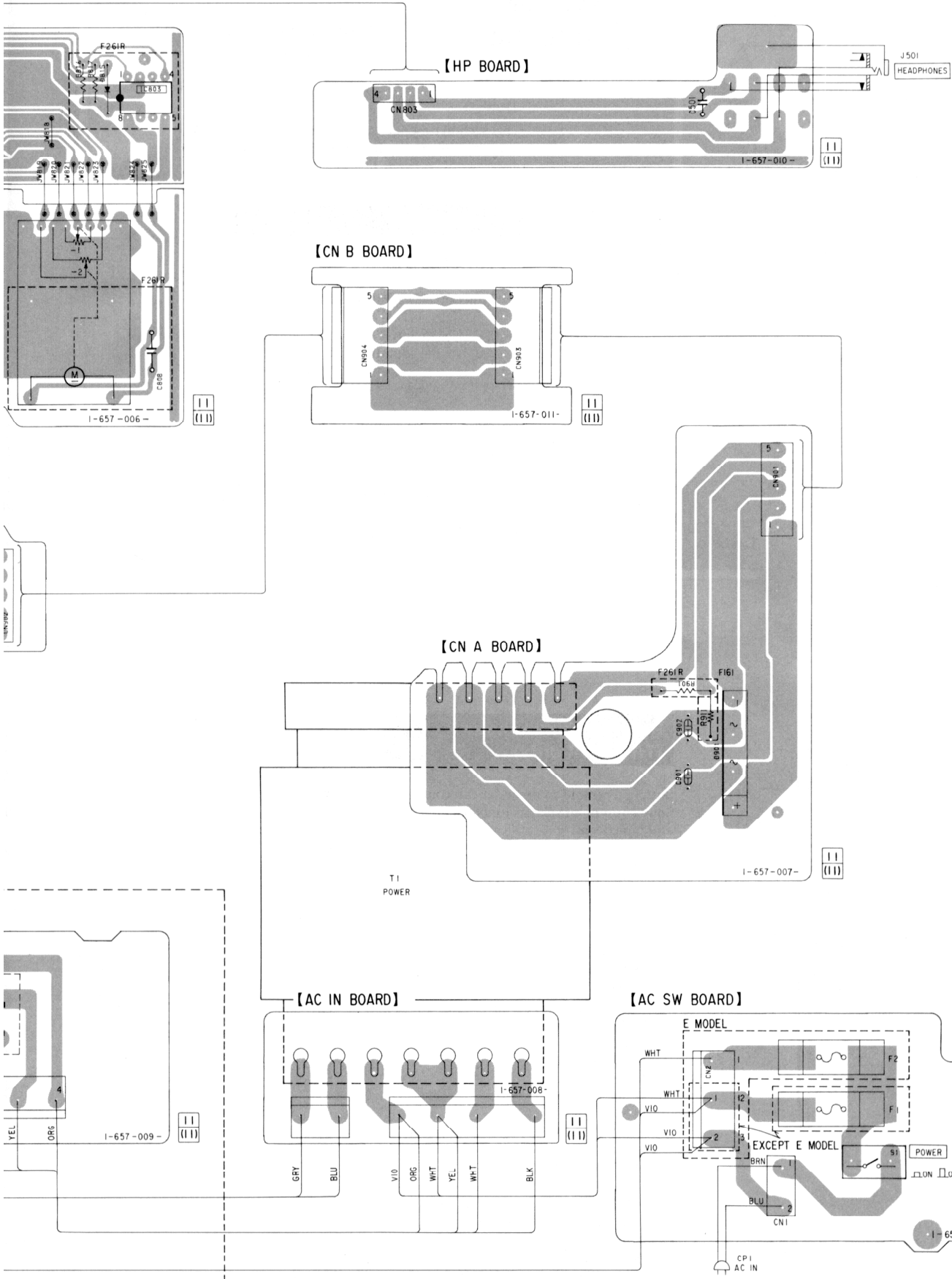

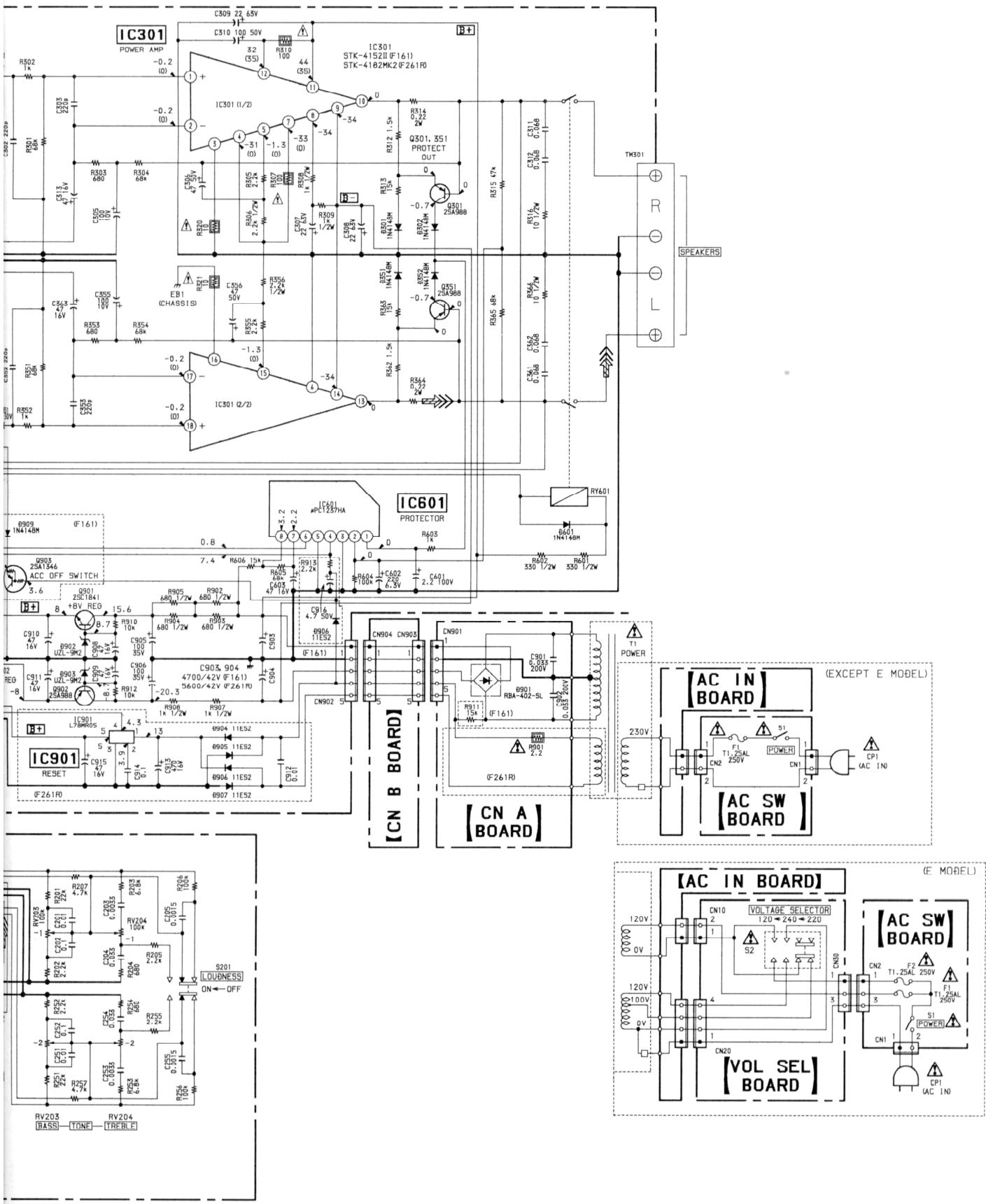

• IC Block Diagrams

IC103 LC7818

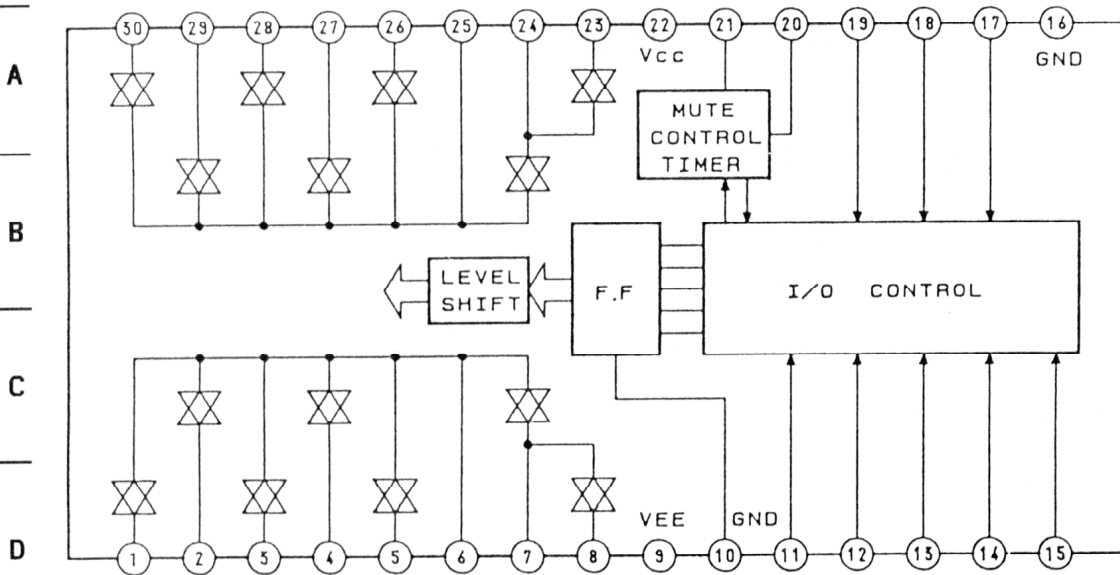

IC803 LB1639

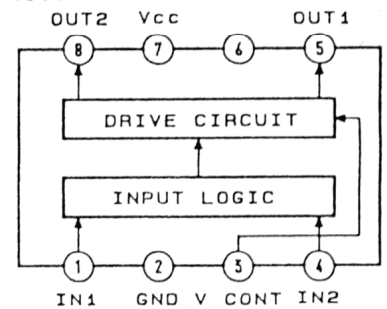

IC601 μ PC1237HA

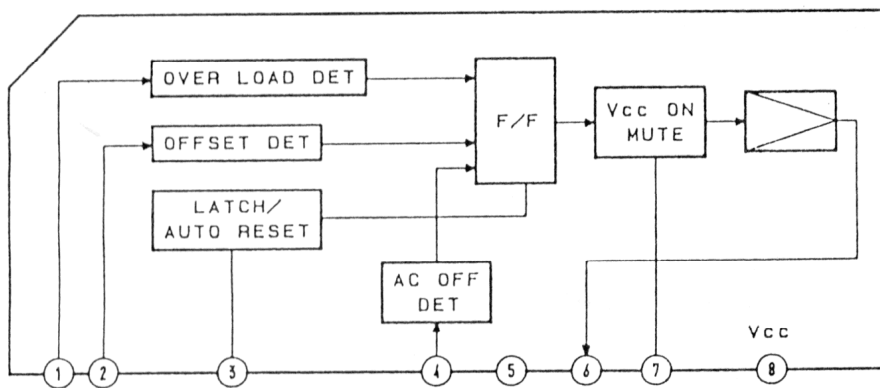

• Waveform

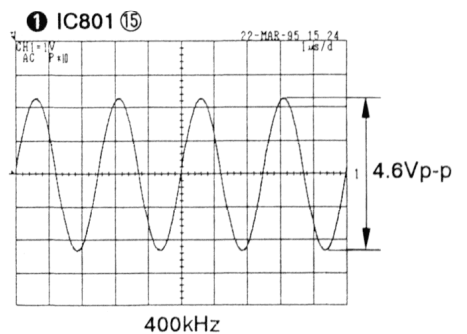

NOTE

- All capacitors are in μ F unless otherwise noted. pF: μ F
- 50W or less are not indicated except for electrolytics and tantalums.
- All resistors are in Ω and 1/4W or less unless otherwise specified.
- : nonflammable resistor.
- : panel designation.

Note: The components identified by mark or dotted line with mark are critical for safety. Replace only with part number specified.

- Abbreviation
F161: TA-F161
F261R: TA-F261R

- : B+ Line.
- : B- Line.
- Voltages and waveforms are dc with respect to ground under no-signal (detuned) conditions.
- no mark: TA-F161/F261R
(): TA-F261R
- Voltages are taken with a VOM (Input impedance 10M Ω). Voltage variations may be noted due to normal production tolerances.
- Waveforms are taken with an oscilloscope. Voltage variations may be noted due to normal production tolerances.
- Circled numbers refer to waveforms.
- Signal path.

: PHONO

(2) CHASSIS SECTION

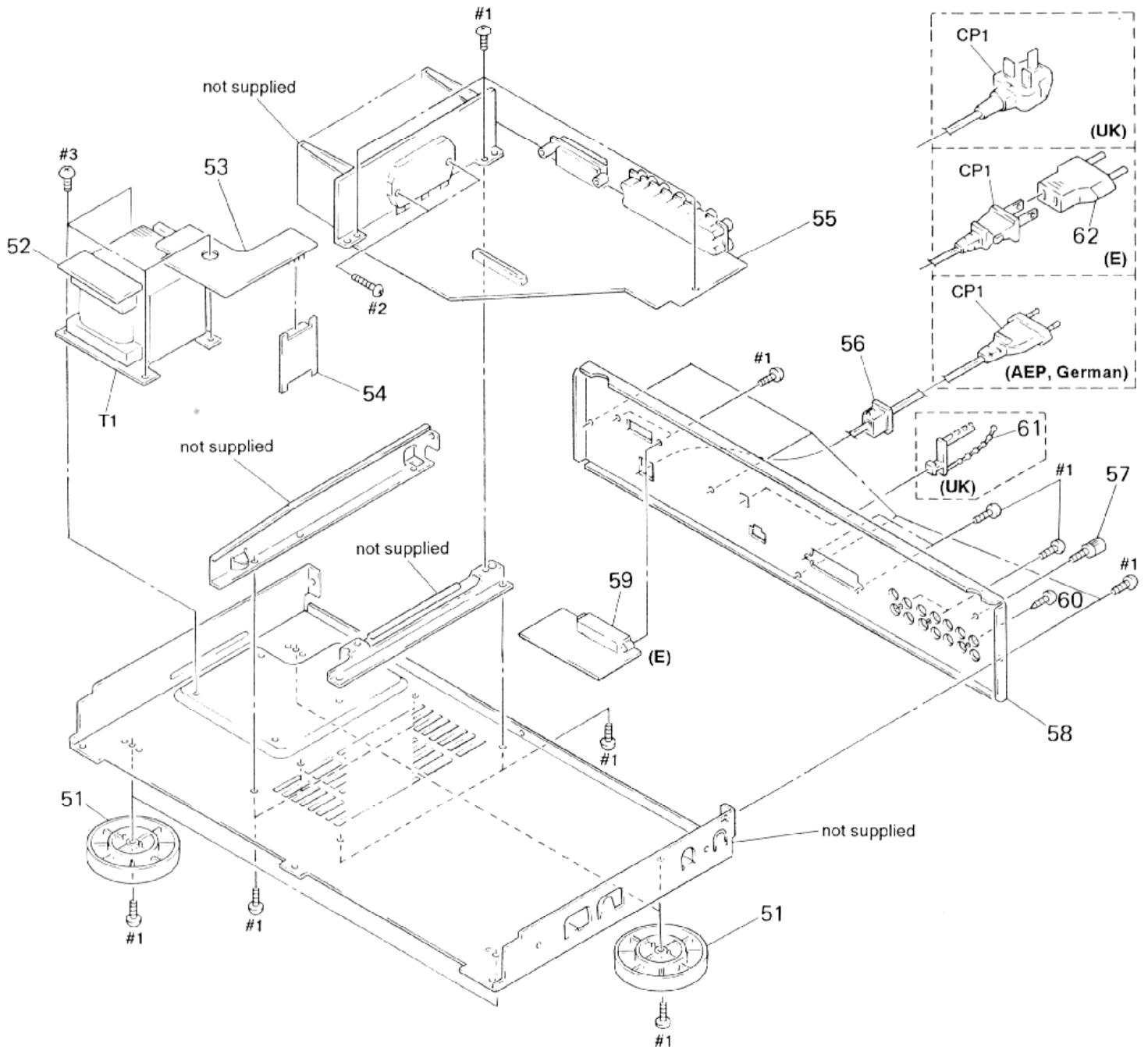

Ref. No.	Part No.	Description	Remark
	51	4-956-885-11 FOOT (F58175S2W)	
*	52	1-657-008-11 AC IN BOARD	
*	53	1-657-007-11 CN A BOARD	
*	54	1-657-011-11 CN B BOARD	
*	55	A-4378-090-A MAIN BOARD, COMPLETE (F261R)	
*	55	A-4378-103-A MAIN BOARD, COMPLETE (F161)	
△	56	3-703-244-00 BUSHING (2104), CORD (AEP, German, UK)	
*	56	3-703-571-11 BUSHING (S) (4516), CORD (E)	
*	57	4-947-010-01 SCREW, FEEDER FIXED	
*	58	4-973-969-01 PANEL, BACK (F261R: AEP, German)	
*	58	4-973-969-11 PANEL, BACK (F261R: UK)	
*	58	4-973-969-21 PANEL, BACK (E)	

Ref. No.	Part No.	Description	Remark
*	58	4-974-362-01 PANEL, BACK (F161: AEP, German)	
*	58	4-974-362-11 PANEL, BACK (F161: UK)	
*	59	1-657-009-11 VOL SEL BOARD (E)	
	60	3-704-515-11 SCREW (BV/RING)	
	61	4-956-370-02 BAND, PLUG FIXED (UK)	
△	62	1-569-007-11 ADAPTER, CONVERSION 2P (E)	
△	CP1	1-558-943-41 CORD, POWER (E)	
△	CP1	1-575-651-21 CORD, POWER (AEP, German)	
△	CP1	1-696-586-11 CORD, POWER (UK)	
△	T1	1-427-967-11 TRANSFORMER, POWER (F261R: AEP, UK, German)	
△	T1	1-427-968-11 TRANSFORMER, POWER (E)	
△	T1	1-427-969-11 TRANSFORMER, POWER (F161)	

Note: The components identified by mark \triangle or dotted line with mark \triangle are critical for safety. Replace only with part number specified.

AC IN

AC SW

CN A

CN B

CONT

SECTION 4 ELECTRICAL PARTS LIST

NOTE:

- Due to standardization, replacements in the parts list may be different from the parts specified in the diagrams or the components used on the set.
- -XX and -X mean standardized parts, so they may have some difference from the original one.
- RESISTORS
All resistors are in ohms.
METAL: Metal-film resistor.
METAL OXIDE: Metal oxide-film resistor.
F: nonflammable
- Abbreviation
G: German

- Items marked "*" are not stocked since they are seldom required for routine service. Some delay should be anticipated when ordering these items.
- SEMICONDUCTORS
In each case, u: μ , for example:
uA.: μ A. uPA.: μ PA.
uPB.: μ PB. uPC.: μ PC. uPD.: μ PD.
- CAPACITORS
uF: μ F
- COILS
uH: μ H

The components identified by mark Δ or dotted line with mark Δ are critical for safety. Replace only with part number specified.

When indicating parts by reference number, please include the board.

Ref. No.	Part No.	Description	Remark
*	1-657-008-11	AC IN BOARD *****	

*	1-657-013-11	AC SW BOARD *****	
	1-533-293-11	FUSE HOLDER < CONNECTOR >	
+ CN1	1-580-230-31	PIN, CONNECTOR (PC BOARD) 2P	
	CN2 1-564-321-00	PIN, CONNECTOR 2P (AEP, UK, G)	
	CN2 1-564-687-11	PIN, CONNECTOR 3P (E) < SWITCH >	
Δ S1	1-572-267-51	SWITCH, PUSH (1 KEY) (POWER) *****	
*	1-657-007-11	CN A BOARD ***** < CAPACITOR >	
	C901 1-106-379-12	MYLAR 0.033uF 5% 200V	
	C902 1-106-379-12	MYLAR 0.033uF 5% 200V < CONNECTOR >	
	CN901 1-750-388-11	PIN, CONNECTOR 5P < DIODE >	
	D901 8-719-025-03	DIODE RBA-402-SL < RESISTOR >	
Δ R901	1-249-451-11	CARBON 2.2 5% 1/4W F (F261R)	
	R911 1-249-431-11	CARBON 15K 5% 1/4W (F161) *****	

Ref. No.	Part No.	Description	Remark
*	1-657-011-11	CN B BOARD ***** < CONNECTOR >	
	CN903 1-750-390-11	SOCKET 5P	
	CN904 1-750-390-11	SOCKET 5P *****	
*	A-4378-091-A	CONT BOARD, COMPLETE (F261R)	
*	A-4378-104-A	CONT BOARD, COMPLETE (F161) *****	
< CAPACITOR >			
	C201 1-136-153-00	FILM 0.01uF 5% 50V	
	C202 1-136-165-00	FILM 0.1uF 5% 50V	
	C203 1-130-477-00	MYLAR 0.0033uF 5% 50V	
	C204 1-136-159-00	FILM 0.033uF 5% 50V	
	C205 1-130-473-00	MYLAR 0.0015uF 5% 50V	
	C251 1-136-153-00	FILM 0.01uF 5% 50V	
	C252 1-136-165-00	FILM 0.1uF 5% 50V	
	C253 1-130-477-00	MYLAR 0.0033uF 5% 50V	
	C254 1-136-159-00	FILM 0.033uF 5% 50V	
	C255 1-130-473-00	MYLAR 0.0015uF 5% 50V	
	C801 1-124-907-11	ELECT 10uF 20% 50V (F261R)	
	C802 1-164-159-11	CERAMIC 0.1uF 50V (F261R)	
	C803 1-162-284-31	CERAMIC 150PF 10% 50V (F261R)	
	C804 1-162-284-31	CERAMIC 150PF 10% 50V (F261R)	
	C805 1-161-494-00	CERAMIC 0.022uF 25V	
	C806 1-162-294-31	CERAMIC 0.001uF 10% 50V (F261R)	
	C807 1-162-294-31	CERAMIC 0.001uF 10% 50V (F261R)	
	C808 1-164-159-11	CERAMIC 0.1uF 50V (F261R)	
< CONNECTOR >			
	CN801 1-695-218-11	SOCKET, CONNECTOR 33P	
	CN802 1-562-087-00	SOCKET, CONNECTOR 4P < DIODE >	
	D801 8-719-987-63	DIODE 1N4148M (F261R)	
	D802 8-719-313-72	LED SEL3810A-CD (TAPE1/DAT)	

MAIN

Ref. No.	Part No.	Description	Remark		
*	A-4378-090-A	MAIN BOARD, COMPLETE (F261R)			
*	A-4378-103-A	MAIN BOARD, COMPLETE (F161)			

< CAPACITOR >					
C101	1-162-286-31	CERAMIC	220PF	10%	50V
C102	1-126-963-11	ELECT	4.7uF	20%	50V
C103	1-162-282-31	CERAMIC	100PF	10%	50V
C104	1-104-664-11	ELECT	47uF	20%	16V
C105	1-130-480-00	MYLAR	0.0056uF	5%	50V
C106	1-130-473-00	MYLAR	0.0015uF	5%	50V
C107	1-126-963-11	ELECT	4.7uF	20%	50V
C108	1-124-903-11	ELECT	1uF	20%	50V
C151	1-162-286-31	CERAMIC	220PF	10%	50V
C152	1-126-963-11	ELECT	4.7uF	20%	50V
C153	1-162-282-31	CERAMIC	100PF	10%	50V
C154	1-104-664-11	ELECT	47uF	20%	16V
C155	1-130-480-00	MYLAR	0.0056uF	5%	50V
C156	1-130-473-00	MYLAR	0.0015uF	5%	50V
C157	1-126-963-11	ELECT	4.7uF	20%	50V
C158	1-124-903-11	ELECT	1uF	20%	50V
C301	1-124-907-11	ELECT	10uF	20%	50V
C302	1-162-286-31	CERAMIC	220PF	10%	50V
C303	1-162-286-31	CERAMIC	220PF	10%	50V
C305	1-124-443-00	ELECT	100uF	20%	10V
C306	1-124-910-11	ELECT	47uF	20%	50V
C307	1-124-916-11	ELECT	22uF	20%	63V
C308	1-124-916-11	ELECT	22uF	20%	63V
C309	1-124-916-11	ELECT	22uF	20%	63V
C310	1-124-122-11	ELECT	100uF	20%	50V
C311	1-136-163-00	FILM	0.068uF	5%	50V
C312	1-136-163-00	FILM	0.068uF	5%	50V
C313	1-104-664-11	ELECT	47uF	20%	16V
C351	1-124-907-11	ELECT	10uF	20%	50V
C352	1-162-286-31	CERAMIC	220PF	10%	50V
C353	1-162-286-31	CERAMIC	220PF	10%	50V
C355	1-124-443-00	ELECT	100uF	20%	10V
C356	1-124-910-11	ELECT	47uF	20%	50V
C361	1-136-163-00	FILM	0.068uF	5%	50V
C362	1-136-163-00	FILM	0.068uF	5%	50V
C363	1-104-664-11	ELECT	47uF	20%	16V
C601	1-124-925-11	ELECT	2.2uF	20%	100V
C602	1-104-666-11	ELECT	220uF	20%	6.3V
C603	1-104-664-11	ELECT	47uF	20%	16V
C703	1-164-159-11	CERAMIC	0.1uF		50V
C704	1-161-494-00	CERAMIC	0.022uF		25V
C705	1-124-907-11	ELECT	10uF	20%	50V
C706	1-126-926-11	ELECT	1000uF	20%	10V
C707	1-124-907-11	ELECT	10uF	20%	50V

Ref. No.	Part No.	Description	Remark		
C903	1-126-224-11	ELECT	4700uF	20%	42V(F161)
C903	1-111-252-11	ELECT	5600uF	20%	42V(F261R)
C904	1-126-224-11	ELECT	4700uF	20%	42V(F161)
C904	1-111-252-11	ELECT	5600uF	20%	42V(F261R)
C905	1-126-968-11	ELECT	100uF	20%	35V
C906	1-126-968-11	ELECT	100uF	20%	35V
C908	1-104-664-11	ELECT	47uF	20%	16V
C909	1-104-664-11	ELECT	47uF	20%	16V
C910	1-104-664-11	ELECT	47uF	20%	16V
C911	1-104-664-11	ELECT	47uF	20%	16V
C912	1-136-153-00	FILM	0.01uF	5%	50V(F261R)
C913	1-126-941-11	ELECT	470uF	20%	16V(F261R)
C914	1-136-165-00	FILM	0.1uF	5%	50V(F261R)
C915	1-104-664-11	ELECT	47uF	20%	16V(F261R)
C916	1-126-963-11	ELECT	4.7uF	20%	50V(F161)

< CONNECTOR >

CN701	1-695-218-11	SOCKET, CONNECTOR 33P			
CN702	1-566-213-11	PIN, CONNECTOR4P (TUNER CONTROL OUT)			(F261R)
CN902	1-750-388-11	PIN, CONNECTOR 5P			

< DIODE >

D301	8-719-987-63	DIODE	1N4148M		
D302	8-719-987-63	DIODE	1N4148M		
D351	8-719-987-63	DIODE	1N4148M		
D352	8-719-987-63	DIODE	1N4148M		
D601	8-719-987-63	DIODE	1N4148M		
D701	8-719-987-63	DIODE	1N4148M		
D702	8-719-987-63	DIODE	1N4148M		
D703	8-719-933-35	DIODE	HZS6A3L		
D704	8-719-987-63	DIODE	1N4148M		
D705	8-719-987-63	DIODE	1N4148M		
D706	8-719-987-63	DIODE	1N4148M		
D707	8-719-987-63	DIODE	1N4148M		
D902	8-719-001-15	DIODE	UZL-9M2		
D903	8-719-001-15	DIODE	UZL-9M2		
D904	8-719-200-82	DIODE	11ES2 (F261R)		
D905	8-719-200-82	DIODE	11ES2 (F261R)		
D906	8-719-200-82	DIODE	11ES2		
D907	8-719-200-82	DIODE	11ES2 (F261R)		
D909	8-719-987-63	DIODE	1N4148M (F161)		

< TERMINAL BOARD >

EB1	1-537-770-11	TERMINAL BOARD, GROUND			
-----	--------------	------------------------	--	--	--

Ref. No.	Part No.	Description	Remark
D803	8-719-018-46	LED SEL3510C-CD (TAPE2/MD)	
D804	8-719-018-46	LED SEL3510C-CD (CD)	
D805	8-719-018-46	LED SEL3510C-CD (TUNER)	
D806	8-719-018-46	LED SEL3510C-CD (PHONO)	
D807	8-719-987-63	DIODE 1N4148M	
D808	8-719-987-63	DIODE 1N4148M	
D809	8-719-987-63	DIODE 1N4148M	
D810	8-719-987-63	DIODE 1N4148M	
D811	8-719-987-63	DIODE 1N4148M	
D812	8-719-987-63	DIODE 1N4148M	
D813	8-719-987-63	DIODE 1N4148M	
D814	8-719-987-63	DIODE 1N4148M	
D815	8-719-200-82	DIODE 11ES2 (F261R)	
D816	8-719-987-63	DIODE 1N4148M	
< IC >			
IC801	8-759-077-08	IC M50761-291P (F261R)	
IC802	8-749-923-43	IC GP1U57XB (F261R)	
IC803	8-759-820-62	IC LB1639 (F261R)	
< TRANSISTOR >			
Q801	8-729-620-05	TRANSISTOR 2SC2603-EF (F261R)	
Q802	8-729-620-05	TRANSISTOR 2SC2603-EF (F261R)	
< RESISTOR >			
R201	1-249-433-11	CARBON 22K 5% 1/4W	
R202	1-249-421-11	CARBON 2.2K 5% 1/4W	
R203	1-249-427-11	CARBON 6.8K 5% 1/4W	
R204	1-249-415-11	CARBON 680 5% 1/4W	
R205	1-249-421-11	CARBON 2.2K 5% 1/4W	
R206	1-249-441-11	CARBON 100K 5% 1/4W	
R207	1-249-425-11	CARBON 4.7K 5% 1/4W	
R251	1-249-433-11	CARBON 22K 5% 1/4W	
R252	1-249-421-11	CARBON 2.2K 5% 1/4W	
R253	1-249-427-11	CARBON 6.8K 5% 1/4W	
R254	1-249-415-11	CARBON 680 5% 1/4W	
R255	1-249-421-11	CARBON 2.2K 5% 1/4W	
R256	1-249-441-11	CARBON 100K 5% 1/4W	
R257	1-249-425-11	CARBON 4.7K 5% 1/4W	
R317	1-247-750-11	CARBON 680 5% 1/2W	
R367	1-247-750-11	CARBON 680 5% 1/2W	
R801	1-249-417-11	CARBON 1K 5% 1/4W (F261R)	
R802	1-249-417-11	CARBON 1K 5% 1/4W (F261R)	
R803	1-249-429-11	CARBON 10K 5% 1/4W (F261R)	
R804	1-249-393-11	CARBON 10 5% 1/4W (F261R)	
R805	1-247-903-00	CARBON 1M 5% 1/4W (F261R)	
R806	1-249-423-11	CARBON 3.3K 5% 1/4W (F261R)	

Ref. No.	Part No.	Description	Remark
R807	1-249-393-11	CARBON 10 5% 1/4W (F261R)	
R808	1-249-393-11	CARBON 10 5% 1/4W (F261R)	
R809	1-249-415-11	CARBON 680 5% 1/4W	
R810	1-249-415-11	CARBON 680 5% 1/4W	
R811	1-249-433-11	CARBON 22K 5% 1/4W	
R812	1-249-433-11	CARBON 22K 5% 1/4W	
R813	1-249-433-11	CARBON 22K 5% 1/4W	
R814	1-249-433-11	CARBON 22K 5% 1/4W	
R815	1-249-433-11	CARBON 22K 5% 1/4W	
R816	1-249-429-11	CARBON 10K 5% 1/4W (F261R)	
R817	1-249-429-11	CARBON 10K 5% 1/4W (F261R)	
< VARIABLE RESISTOR >			
RV201	1-223-396-11	RES. VAR. CARBON 100K/100K (BALANCE)	
RV202	1-241-408-11	RES. VAR. CARBON 100K/100K (VOLUME)	(F161)
RV202	1-241-426-11	RES. VAR. CARBON 100K/100K (VOLUME)	(F261R)
RV203	1-223-397-11	RES. VAR. CARBON 100K/100K (TONE BASS)	
RV204	1-223-397-11	RES. VAR. CARBON 100K/100K (TONE TREBLE)	
< SWITCH >			
S201	1-762-370-11	SWITCH, PUSH (LOUDNESS)	
SW801	1-554-303-21	SWITCH, TACTILE (TAPE1/DAT)	
SW802	1-554-303-21	SWITCH, TACTILE (TAPE2/MD)	
SW803	1-554-303-21	SWITCH, TACTILE (CD)	
SW804	1-554-303-21	SWITCH, TACTILE (TUNER)	
SW805	1-554-303-21	SWITCH, TACTILE (PHONO)	
< VIBRATOR >			
X801	1-577-077-11	OSCILLATOR, CERAMIC (400KHz) (F261R)	

*	1-657-010-11	HP BOARD	

< CAPACITOR >			
C501	1-164-096-11	CERAMIC 0.01uF	50V
< CONNECTOR >			
CN803	1-560-941-00	PIN, CONNECTOR 4P	
< JACK >			
J501	1-563-347-11	JACK, LARGE TYPE (HEADPHONES)	

Ref. No.	Part No.	Description	Remark
< IC >			
IC101	8-759-184-02	IC M5218AL-D	
IC102	8-759-000-49	IC MC14066BCP	
IC103	8-759-802-52	IC LC7818	
IC301	8-749-941-52	IC STK-415211 (F161)	
IC301	8-749-900-34	IC STK-4182MK2 (F261R)	
IC601	8-759-111-68	IC μ PC1237HA	
IC901	8-759-820-84	IC L78MR05 (F261R)	
< JACK >			
J101	1-566-883-81	JACK, PIN 6P (PHONO IN) (TUNER IN) (CD IN)	
J102	1-566-882-51	JACK, PIN 4P (TAPE2/MD) (REC OUT/IN)	
J103	1-566-882-51	JACK, PIN 4P (TAPE1/DAT) (REC OUT/IN)	
< TRANSISTOR >			
Q101	8-729-141-26	TRANSISTOR 2SC3622A-LK	
Q151	8-729-141-26	TRANSISTOR 2SC3622A-LK	
Q301	8-729-140-82	TRANSISTOR 2SA988-PAFAEA	
Q351	8-729-140-82	TRANSISTOR 2SA988-PAFAEA	
Q701	8-729-119-76	TRANSISTOR 2SA1175-HFE	
Q702	8-729-900-63	TRANSISTOR DTA124ES	
Q703	8-729-900-63	TRANSISTOR DTA124ES	
Q704	8-729-900-36	TRANSISTOR DTC124ES	
Q705	8-729-900-63	TRANSISTOR DTA124ES (F261R)	
Q706	8-729-900-36	TRANSISTOR DTC124ES (F261R)	
Q707	8-729-900-36	TRANSISTOR DTC124ES	
Q708	8-729-900-63	TRANSISTOR DTA124ES	
Q709	8-729-900-36	TRANSISTOR DTC124ES	
Q710	8-729-900-63	TRANSISTOR DTA124ES	
Q901	8-729-140-84	TRANSISTOR 2SC1841-PAFAEA	
Q902	8-729-140-82	TRANSISTOR 2SA988-PAFAEA	
Q903	8-729-900-63	TRANSISTOR DTA124ES (F161)	
< RESISTOR >			
R101	1-247-807-31	CARBON 100 5% 1/4W	
R102	1-249-417-11	CARBON 1K 5% 1/4W	
R103	1-249-417-11	CARBON 1K 5% 1/4W	
R104	1-249-417-11	CARBON 1K 5% 1/4W	
R105	1-249-417-11	CARBON 1K 5% 1/4W	
R106	1-249-417-11	CARBON 1K 5% 1/4W	
R107	1-249-417-11	CARBON 1K 5% 1/4W	
R108	1-249-411-11	CARBON 330 5% 1/4W	
R109	1-249-437-11	CARBON 47K 5% 1/4W	
R110	1-249-416-11	CARBON 820 5% 1/4W	
R111	1-247-897-11	CARBON 560K 5% 1/4W	
R112	1-249-437-11	CARBON 47K 5% 1/4W	
R113	1-249-441-11	CARBON 100K 5% 1/4W	
R114	1-249-409-11	CARBON 220 5% 1/4W	

Ref. No.	Part No.	Description	Remark
R115	1-249-427-11	CARBON 6.8K 5% 1/4W	
R151	1-247-807-31	CARBON 100 5% 1/4W	
R152	1-249-417-11	CARBON 1K 5% 1/4W	
R153	1-249-417-11	CARBON 1K 5% 1/4W	
R154	1-249-417-11	CARBON 1K 5% 1/4W	
R155	1-249-417-11	CARBON 1K 5% 1/4W	
R156	1-249-417-11	CARBON 1K 5% 1/4W	
R157	1-249-417-11	CARBON 1K 5% 1/4W	
R158	1-249-411-11	CARBON 330 5% 1/4W	
R159	1-249-437-11	CARBON 47K 5% 1/4W	
R160	1-249-416-11	CARBON 820 5% 1/4W	
R161	1-247-897-11	CARBON 560K 5% 1/4W	
R162	1-249-437-11	CARBON 47K 5% 1/4W	
R163	1-249-441-11	CARBON 100K 5% 1/4W	
R164	1-249-409-11	CARBON 220 5% 1/4W	
R165	1-249-427-11	CARBON 6.8K 5% 1/4W	
R301	1-249-439-11	CARBON 68K 5% 1/4W	
R302	1-249-417-11	CARBON 1K 5% 1/4W	
R303	1-249-415-11	CARBON 680 5% 1/4W	
R304	1-249-439-11	CARBON 68K 5% 1/4W	
R305	1-249-421-11	CARBON 2.2K 5% 1/4W	
R306	1-260-103-11	CARBON 2.2K 5% 1/2W	
Δ R307	1-249-405-11	CARBON 100 5% 1/4W	F
R308	1-260-099-11	CARBON 1K 5% 1/2W	
R309	1-260-099-11	CARBON 1K 5% 1/2W	
Δ R310	1-249-405-11	CARBON 100 5% 1/4W	F
R312	1-249-419-11	CARBON 1.5K 5% 1/4W	
R313	1-249-431-11	CARBON 15K 5% 1/4W	
R314	1-217-151-00	METAL PLATE 0.22 2W	
R315	1-249-437-11	CARBON 47K 5% 1/4W	
R316	1-247-727-11	CARBON 10 5% 1/2W	
Δ R320	1-249-393-11	CARBON 10 5% 1/4W	F
Δ R321	1-249-393-11	CARBON 10 5% 1/4W	F
R351	1-249-439-11	CARBON 68K 5% 1/4W	
R352	1-249-417-11	CARBON 1K 5% 1/4W	
R353	1-249-415-11	CARBON 680 5% 1/4W	
R354	1-249-439-11	CARBON 68K 5% 1/4W	
R355	1-249-421-11	CARBON 2.2K 5% 1/4W	
R356	1-260-103-11	CARBON 2.2K 5% 1/2W	
R362	1-249-419-11	CARBON 1.5K 5% 1/4W	
R363	1-249-431-11	CARBON 15K 5% 1/4W	
R364	1-217-151-00	METAL PLATE 0.22 2W	
R365	1-249-439-11	CARBON 68K 5% 1/4W	
R366	1-247-727-11	CARBON 10 5% 1/2W	
R601	1-247-745-11	CARBON 330 5% 1/2W	
R602	1-247-745-11	CARBON 330 5% 1/2W	
R603	1-249-417-11	CARBON 1K 5% 1/4W	
R604	1-249-441-11	CARBON 100K 5% 1/4W	
R605	1-249-439-11	CARBON 68K 5% 1/4W	

The components identified by mark Δ or dotted line with mark Δ are critical for safety. Replace only with part number specified.

TA-F161/F261R

MAIN **VOL SEL**

Ref. No.	Part No.	Description	Quantity	Percentage	Remark
R606	1-249-431-11	CARBON	15K	5%	1/4W
R701	1-247-903-00	CARBON	1M	5%	1/4W
R702	1-249-437-11	CARBON	47K	5%	1/4W
R703	1-249-433-11	CARBON	22K	5%	1/4W
R704	1-249-433-11	CARBON	22K	5%	1/4W
R705	1-249-433-11	CARBON	22K	5%	1/4W
R707	1-249-433-11	CARBON	22K	5%	1/4W
R708	1-247-807-31	CARBON	100	5%	1/4W
R709	1-249-433-11	CARBON	22K	5%	1/4W
R710	1-249-433-11	CARBON	22K	5%	1/4W (F261R)
R711	1-249-435-11	CARBON	33K	5%	1/4W (F261R)
R712	1-249-435-11	CARBON	33K	5%	1/4W
R713	1-249-433-11	CARBON	22K	5%	1/4W
R714	1-249-433-11	CARBON	22K	5%	1/4W
R902	1-247-750-11	CARBON	680	5%	1/2W
R903	1-247-750-11	CARBON	680	5%	1/2W
R904	1-247-750-11	CARBON	680	5%	1/2W
R905	1-247-750-11	CARBON	680	5%	1/2W
R907	1-247-752-11	CARBON	1K	5%	1/2W
R908	1-247-752-11	CARBON	1K	5%	1/2W
R910	1-249-429-11	CARBON	10K	5%	1/4W
R912	1-249-429-11	CARBON	10K	5%	1/4W
R913	1-249-421-11	CARBON	2.2K	5%	1/4W (F161)
		< RELAY >			
RY601	1-515-920-11	RELAY (24V)			
		< TERMINAL >			
TM301	1-537-238-11	TERMINAL BOARD (SPEAKERS)			

*	1-657-009-11	VOL. SEL BOARD (E)			

		< CONNECTOR >			
CN10	1-564-321-00	PIN, CONNECTOR 2P (E)			
CN20	1-568-106-11	PIN, CONNECTOR 4P (E)			
CN30	1-564-687-11	PIN, CONNECTOR 3P (E)			
		< SWITCH >			
△S2	1-572-009-11	SELECTOR, VOLTAGE (E)			

Ref. No.	Part No.	Description	Remark
		MISCELLANEOUS	

11	1-765-353-11	WIRE (FLAT TYPE) (33 CORE)	
△62	1-569-007-11	ADAPTER, CONVERSION 2P (E)	
△CP1	1-558-943-41	CORD, POWER (E)	
△CP1	1-575-651-21	CORD, POWER (AEP, German)	
△CP1	1-696-586-11	CORD, POWER (UK)	
△F1	1-532-285-00	FUSE T1.25AL/250V	
△F2	1-532-285-00	FUSE T1.25AL/250V (E)	
△T1	1-427-967-11	TRANSFORMER, POWER (F261R; AEP, UK, German)	
△T1	1-427-968-11	TRANSFORMER, POWER (E)	
△T1	1-427-969-11	TRANSFORMER, POWER (F161)	

		ACCESSORIES & PACKING MATERIALS	

	1-467-107-11	REMOTE COMMANDER (RM-S312) (F261R)	
	3-800-052-11	MANUAL, INSTRUCTION (ENGLISH, FRENCH, SPANISH, PORTUGUESE, ITALIAN) (AEP, UK, E)	
	3-800-052-21	MANUAL, INSTRUCTION (GERMAN, DUTCH, SWEDISH, DANISH, FINNISH) (AEP)	
	3-800-052-31	MANUAL, INSTRUCTION (GERMAN) (German)	
	4-941-762-11	COVER (MLY), BATTERY (RM-S312) (F261R)	
*	4-959-584-01	CUSHION	
*	4-974-662-01	INDIVIDUAL CARTON (F161)	
*	4-974-662-11	INDIVIDUAL CARTON (F261R)	

		HARDWARE LIST	

#1	7-685-646-79	SCREW +BVTP 3X8 TYPE2 N-S	
#2	7-685-650-79	SCREW +BVTP 3X16 TYPE2 IT-3	
#3	7-682-560-04	SCREW +BVTT 4X6 (S)	

The components identified by mark △ or dotted line with mark △ are critical for safety. Replace only with part number specified.