

TA-F170/F240

SERVICE MANUAL

AEP Model
E Model
Germany Model
 TA-F170
UK Model
 TA-F170/F240



Photo: TA-F170

SPECIFICATIONS

Amplifier

Continuous RMS power output (both channels driven simultaneously)

Models for Scandinavian countries, Spain and Portugal

TA-F170		
DIN 1 kHz	6 ohms	50 W + 50 W
	8 ohms	40 W + 40 W
20 Hz - 20 kHz	8 ohms	30 W + 30 W THD 0.05 %

Model Germany

TA-F170		
DIN 1 kHz	4 ohms	50 W + 50 W
	8 ohms	35 W + 35 W
20 Hz - 20 kHz	4 ohms	—
20 Hz - 20 kHz	8 ohms	30 W + 30 W THD 0.05 %

Model UK

		TA-F170	TA-F240
DIN 1 kHz	4 ohms	50 W + 50 W	80 W + 80 W
	8 ohms	40 W + 40 W	70 W + 70 W
20 Hz - 20 kHz	8 ohms	30 W + 30 W THD 0.05 %	60 W + 60 W 0.05 %

AEP, E Model

		TA-F170
DIN 1 kHz	4 ohms	50 W + 50 W
	8 ohms	40 W + 40 W
20 Hz - 20 kHz	4 ohms	—
20 Hz - 20 kHz	8 ohms	30 W + 30 W THD 0.05 %

Tone controls

	Response	Turnover frequency
BASS	± 6 dB	500 Hz
TREBLE	± 6 dB	3 kHz

Input

Input jack	Jack type	Sensitivity	Impedance	S/N (weighting network, input level)
PHONO	MM	2.0 mV	50 kilohms	76 dB (A, 5 mV)
	MC	170 μV	100 ohms	75 dB (A, 0.5 mV)
TUNER, CD, AUX, TAPE/DAT	Phono	150 mV	50 kilohms	96 dB (150 mV)

— Continued on next page —

INTEGRATED STEREO AMPLIFIER
SONY®

Output

Output jack	Jack type	Voltage/impedance
REC OUT	Phono	Voltage 150 mV Impedance 1 kohms
SPEAKERS	—	Model for Scandinavian countries, Spain and Portugal Accepts speakers of 6 – 16 ohms. Models for other countries Accepts speakers of 4 – 16 ohms
HEAD-PHONES	Stereo phone	Accepts low and high impedance headphones.

Loudness (Attenuation 30 dB)	+6 dB (100 Hz)/ +3 dB (10 kHz)
Subsonic filter	6 dB/octave, attenuation below 15Hz
Intermodulation (IM) distortion (60 Hz: 7 kHz=4: 1)	Less than 0.05% at rated output
Frequency response	PHONE: RIAA equalization curve ± 0.5 dB TUNER, CD, AUX, TAPE1/DAT: 7 Hz – 100 kHz ± 3 dB
Residual noise	Less than 190 µV (network A)
Damping factor	40 (8 ohms, 1 kHz)
Power requirements	AEP, Germany models: 220 – 230 V AC, 50 Hz UK model: 240 V AC, 50 Hz E model: 120 V, 220 V or 240 V AC adjustable, 50/60 Hz

MODEL IDENTIFICATION

– Specification Labels –

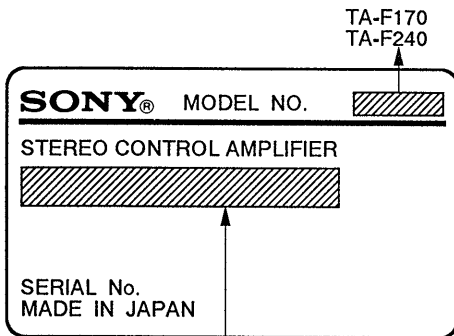

AEP, Germany model:	AC: 220 – 230 V ~50/60Hz	90 W
TA-F170 UK model:	AC: 240 V ~50/60 Hz	250 W
TA-F240 UK model:	AC: 240 V ~50/60 Hz	380 W
E model:	AC: 120/220/240 V ~50/60 Hz	90 W

Power consumption

Models for	F170	F240
UK	250 W	380 W
Germany	95 W	—
AEP, E	90 W	—

Dimensions	Approx. 430 × 135 × 312 mm (w/h/d) (17 × 5 ³ / ₈ × 12 ³ / ₈ inches)
Weight	TA-F170: Approx. 7.6 kg (16 lb 12 oz) TA-F240: Approx. 8 kg (17 lb 10 oz)

* For all the countries except U.K. and Canada, the above values are measured at 230 V AC.

Design and specifications subject to change without notice.

Note

This appliance conforms with EEC directive 87/308/EEC regarding interference suppression.

TABLE OF CONTENTS

<u>Section</u>	<u>Title</u>	<u>Page</u>
	Specifications	1
	Model Identification	2
	Precautions	3
1.	GENERAL	4
	Connections	4
	Parts Identification	4
2.	DISASSEMBLY	5
2-1.	Disassembly Of Front Panel	5
3.	ELECTRICAL ADJUSTMENTS	5
4.	DIAGRAMS	6
4-1.	Block Diagram	6
4-2.	Printed Wiring Boards	8
4-3.	Schematic Diagram	11
5.	EXPLODED VIEWS	14
6.	ELECTRICAL PARTS LIST	16

SAFETY-RELATED COMPONENT WARNING!!

COMPONENTS IDENTIFIED BY MARK OR DOTTED LINE WITH MARK ON THE SCHEMATIC DIAGRAMS AND IN THE PARTS LIST ARE CRITICAL TO SAFE OPERATION. REPLACE THESE COMPONENTS WITH SONY PARTS WHOSE PART NUMBERS APPEAR AS SHOWN IN THIS MANUAL OR IN SUPPLEMENTS PUBLISHED BY SONY.

ATTENTION AU COMPOSANT AYANT RAPPORT À LA SÉCURITÉ!

LES COMPOSANTS IDENTIFIÉS PAR UNE MARQUE SUR LES DIAGRAMMES SCHÉMATIQUES ET LA LISTE DES PIÈCES SONT CRITIQUES POUR LA SÉCURITÉ DE FONCTIONNEMENT. NE REMPLACER CES COMPOSANTS QUE PAR DES PIÈCES SONY DONT LES NUMÉROS SONT DONNÉS DANS CE MANUEL OU DANS LES SUPPLÉMENTS PUBLIÉS PAR SONY.

Precautions

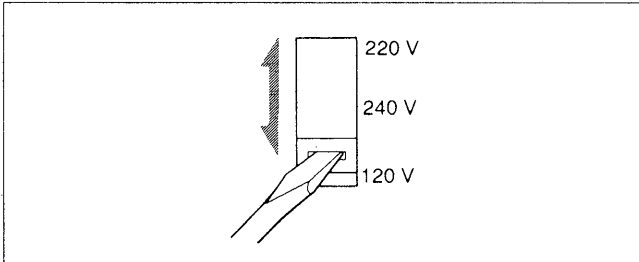

On safety

- Before operating the unit, check that the operating voltage of your unit is identical with the voltage of your local power supply.

Where purchased	Operating voltage
Canada	120 V AC
United Kingdom	240 V AC
Continental European countries	220 – 230 V AC
Other countries	120 V, 220 V or 240 V AC adjustable The voltage selector is located on the rear panel. If the selector must be reset, disconnect the AC power cord and set the selector to the proper voltage of your local power supply.

- Unplug the unit from the wall outlet if it is not to be used for an extended period of time. To disconnect the cord, pull it out by grasping the plug. Never pull the cord itself.
- Should any solid object or liquid fall into the unit, unplug the unit and have it checked by qualified personnel before operating it any further.
- Do not block the ventilation holes on top of the unit. The ventilation holes must be unobstructed for proper operation of the unit and to prolong the life of its components.
- AC power cord must be changed only at the qualified service shop.

On cleaning the cabinet

Clean the cabinet, panels and controls with a soft cloth lightly moistened with a mild detergent solution. Do not use any type of abrasive pad, scouring powder or solvent such as alcohol or benzene.

On repacking

Do not throw away the carton and the packing material. This makes an ideal container when transporting the unit. When shipping the unit, repack it as it was packed at the factory.

If you have any question or problem concerning your unit, please consult your nearest Sony dealer.

Parts Identification/Identification des parties Identificacao de partes/Identificacao dos comandos

Connexions

Connections

Refer to the pages indicated in ● for details.
Pour les détails, se reporter aux pages indiquées dans les cercles noirs.
Para los detalles, refiérase a las páginas indicadas en ●.

Remarques sur les connexions

- Le cordon d'alimentation doit être branché en dernier lieu, après s'être assuré que l'appareil est bien hors tension.
- Les fiches des cordons et les prises sont codées par couleur. Les fiches et prises rouges sont destinées au canal droit (R) et les blanches, au canal gauche (L).
- Insérer les connecteurs des câbles à fond dans les prises. En effet, une connexion relâchée peut provoquer un ronflement ou du bruit.

Notes on Connection

- Connect the AC power cord last. Make sure power is off.
- Cord plugs and jacks are color coded. Red plugs and jacks are for right channel (R) and white ones for left channel (L).
- Fully insert cable connectors into jacks. Loose connections may cause hum or noise.

SECTION 1 GENERAL

This section is extracted from TA-F170/
F240/F270/F470 instruction manual.

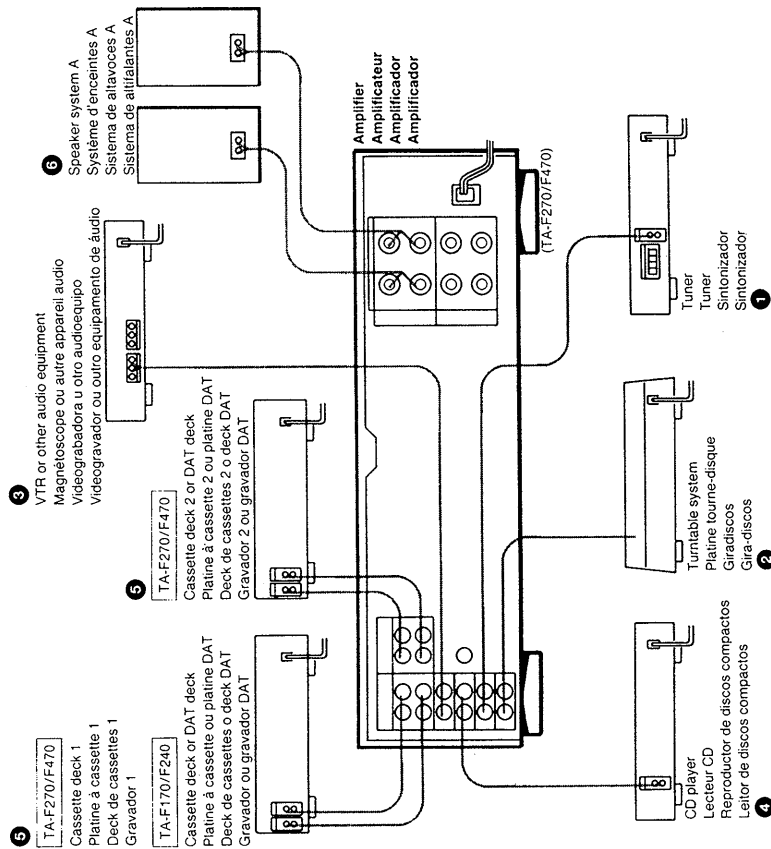
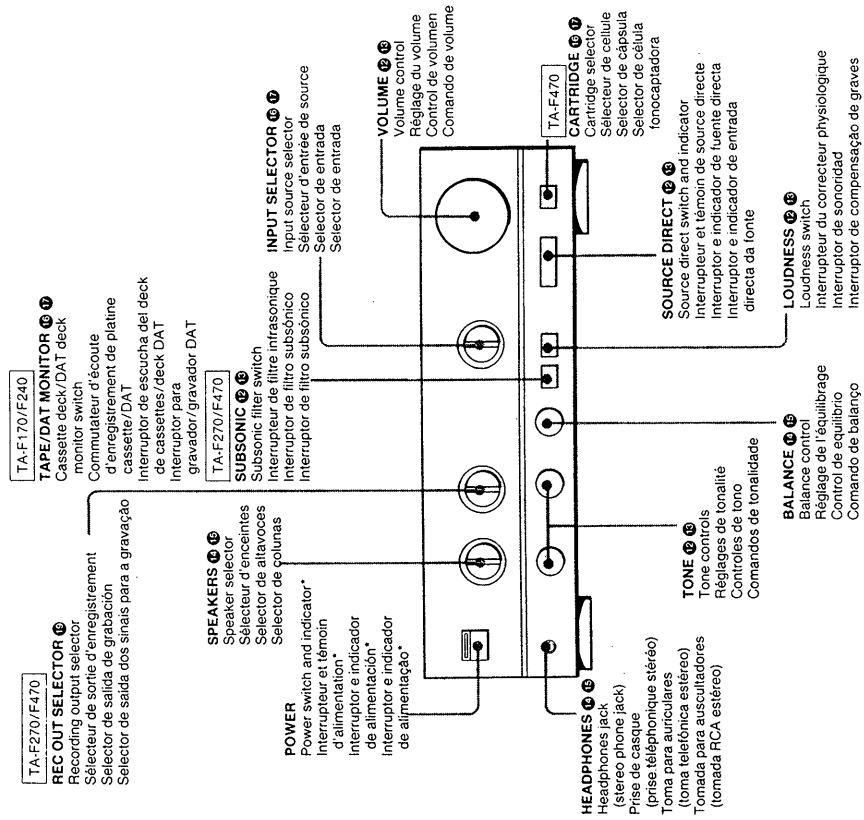

SECTION 2 DISASSEMBLY

2-1. DISASSEMBLY OF FRONT PANEL

Note: Follow the disassembly procedure in the numerical order given.

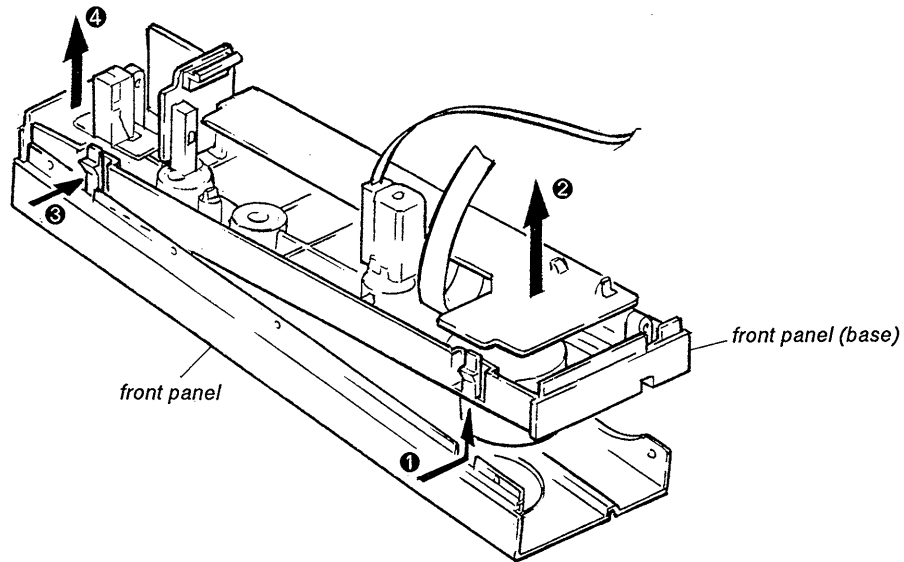

SECTION 3 ELECTRICAL ADJUSTMENT

NOTE:

- Adjustment should be performed 10 minutes after the POWER switch is on (POWER ON).

Bias Current Adjustment

Setting:

VOLUME control: minimum

Adjustment Location:

[AMP BOARD] – Component Side –

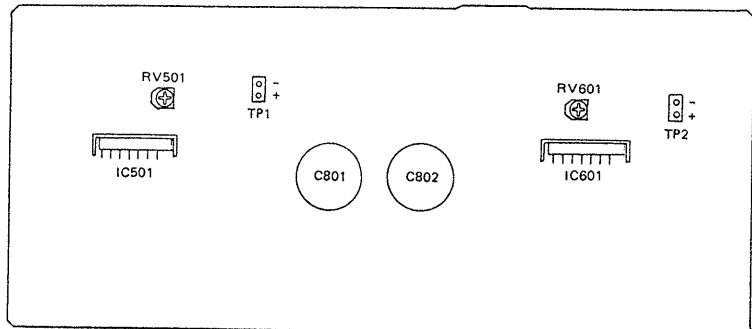
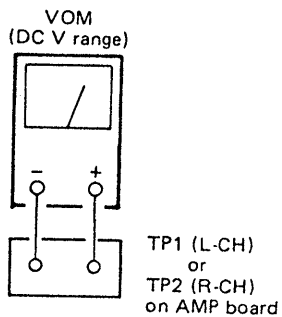

Procedure:

Adjust RV501 (L-CH) and RV601 (R-CH) so as to obtain 4 mV (TA-F120) or 2 mV (TA-F220) at TP1 (L-CH) and TP2 (R-CH) respectively.

SECTION 4
DIAGRAM

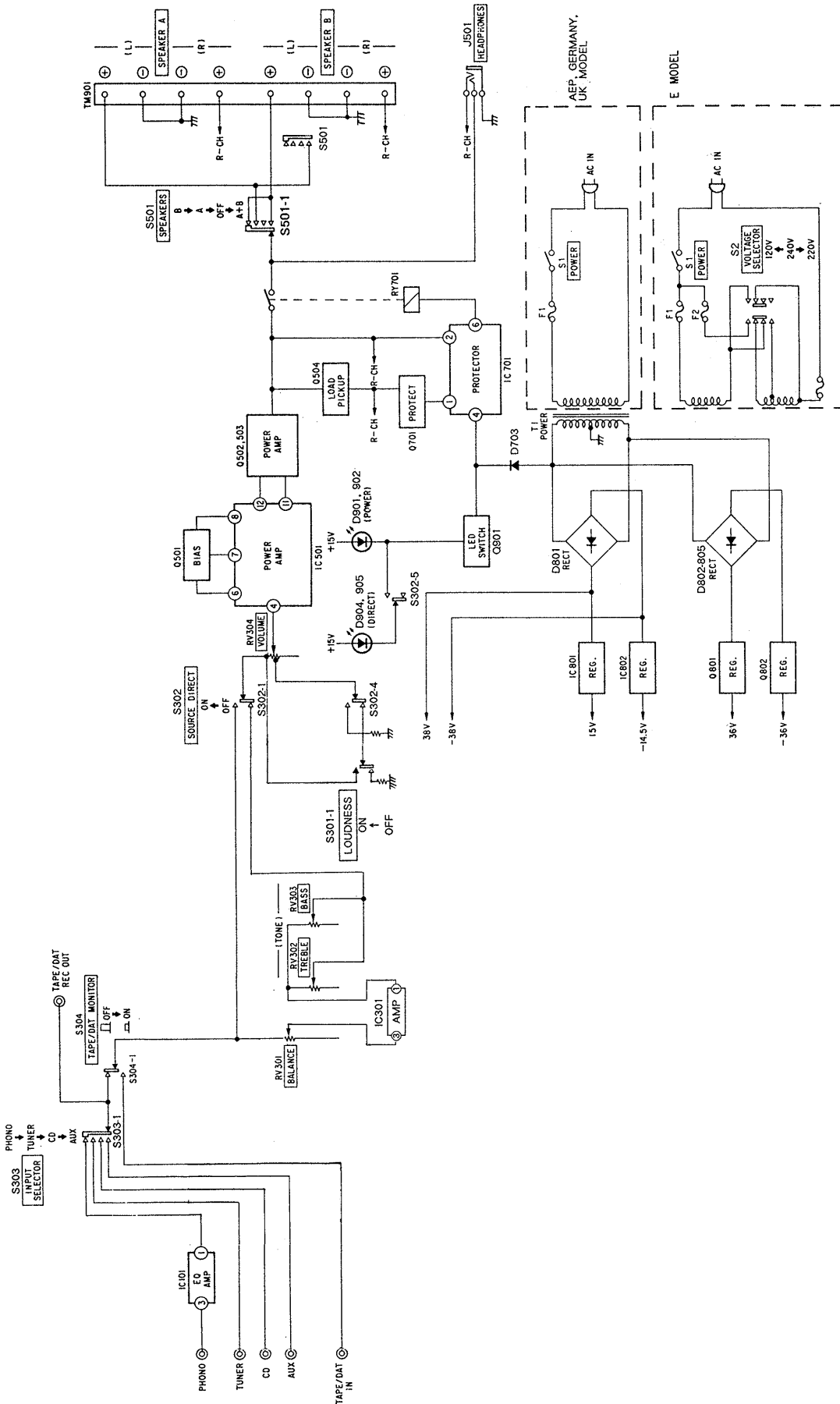

● **Circuit Boards Location**

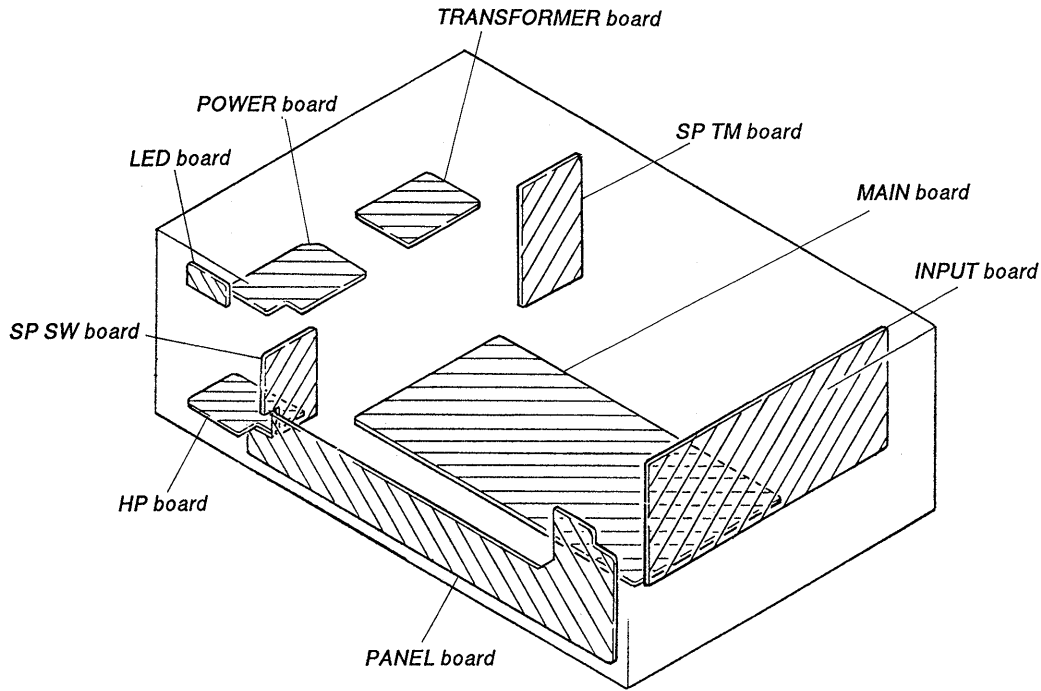

● **Semiconductor Location**

Ref. No.	Location
D501	B-15
D502	B-15
D601	B-11
D602	B-11
D701	D-14
D702	E-14
D703	E-12
D801	E-10
D802	E-13
D803	E-13
D804	F-13
D805	F-13
D901	H-15
D902	H-15
D904	K-8
D905	K-8
IC101	F-4
IC301	J-14
IC501	C-15
IC601	D-9
IC701	D-14
IC801	D-7
IC802	D-8
Q501	A-13
Q502	A-14
Q503	A-12
Q504	B-15
Q601	A-9
Q602	A-10
Q603	A-8
Q604	B-11
Q701	D-14
Q801	E-15
Q802	F-15
Q901	E-15

● **Semiconductor Lead Layouts**

M5218AL
μ PC1237HA



μ PC1298V
μ PC1342V

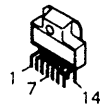

2SB1370-EF
2SD2012

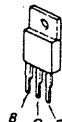

RBV-602-01

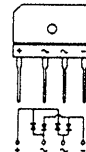

SEL2510C-C

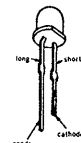

TA7815S

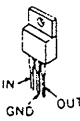

DTA124ES
2SC2603-EF



2SC1841-PAFAEA



1SS120

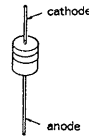

SEL2810A-C

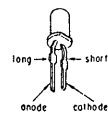

TA7915S

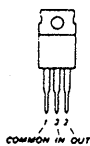

2SA1490-OPY
2SA1491-OY
2SC3854-OY
2SC3855-OY



2SD1312-K



10E2

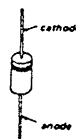

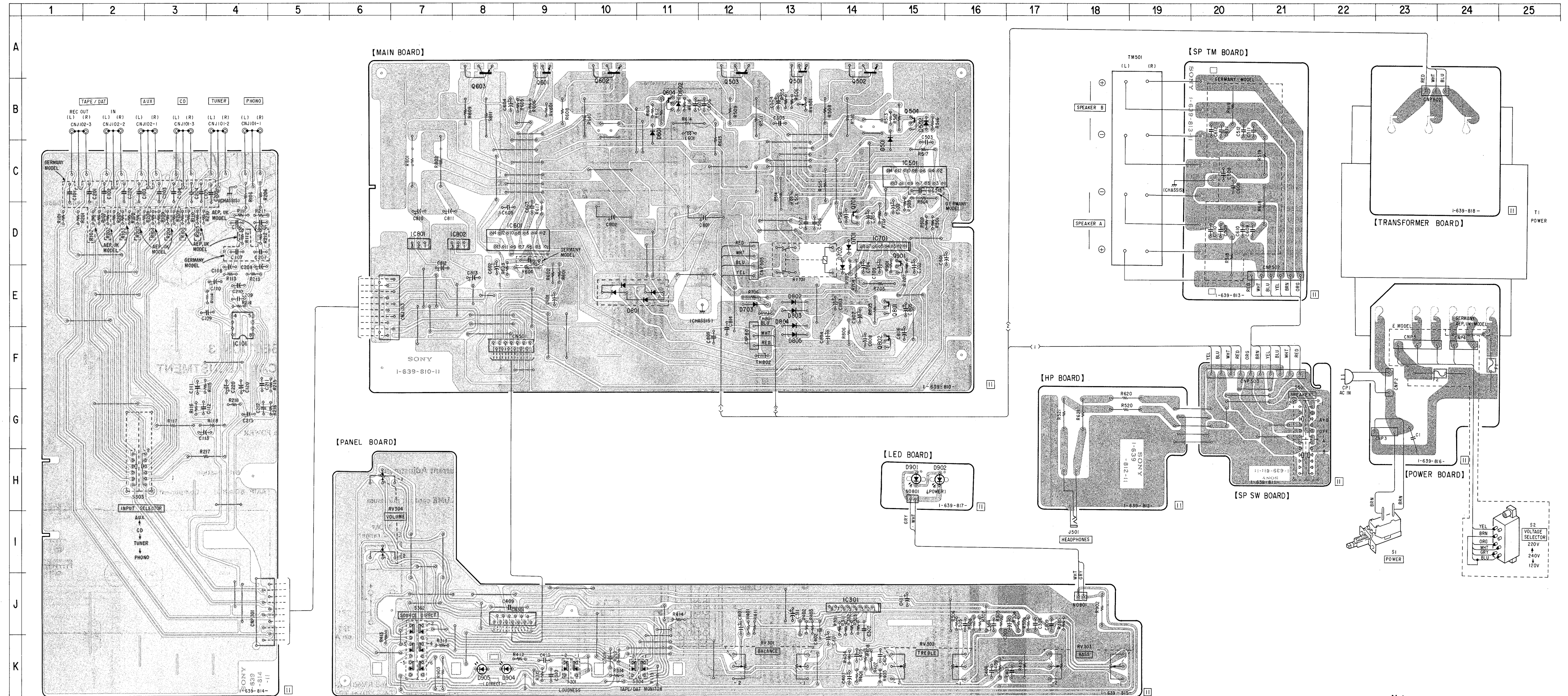

Note:
 ● ○ — : parts extracted from the component side.

4-3. SCHEMATIC DIAGRAM

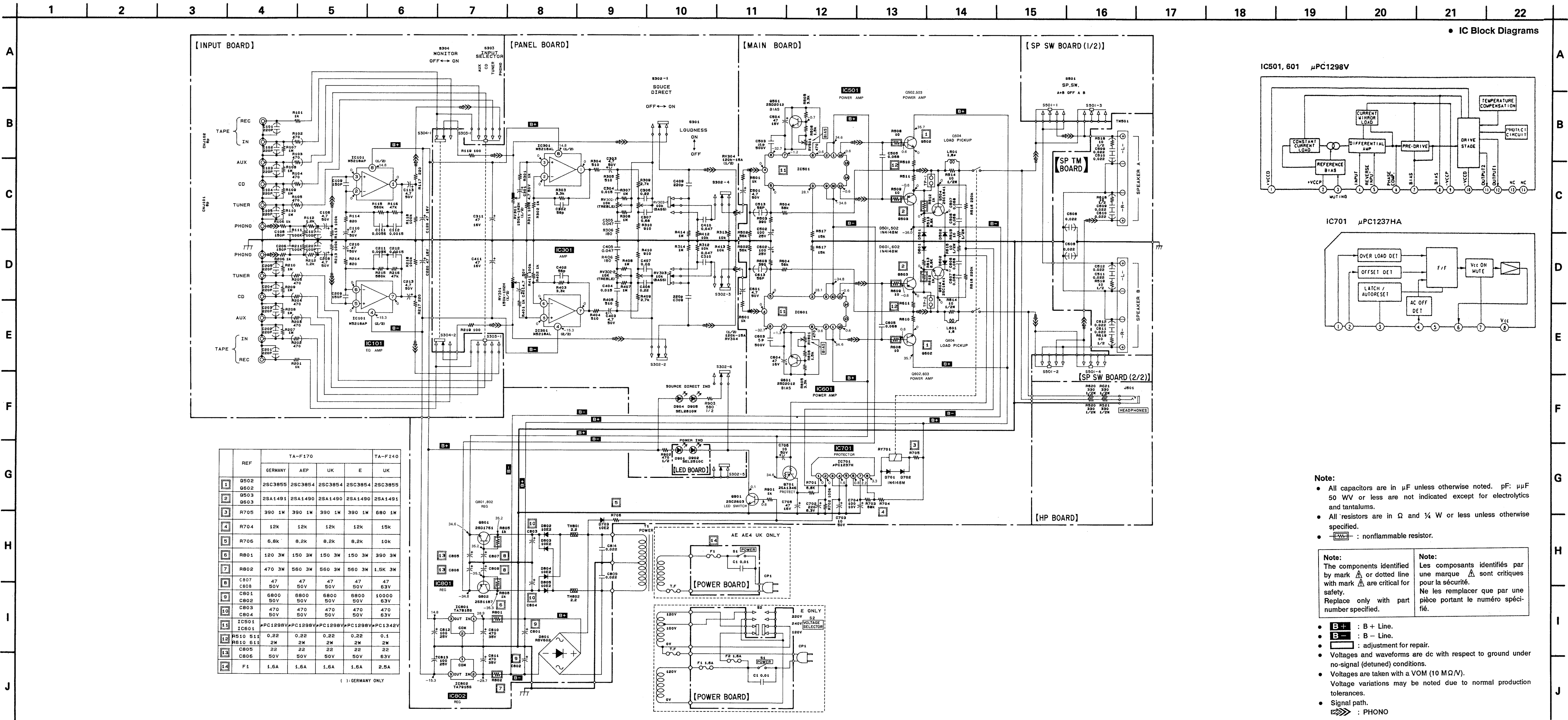

• IC Block Diagrams

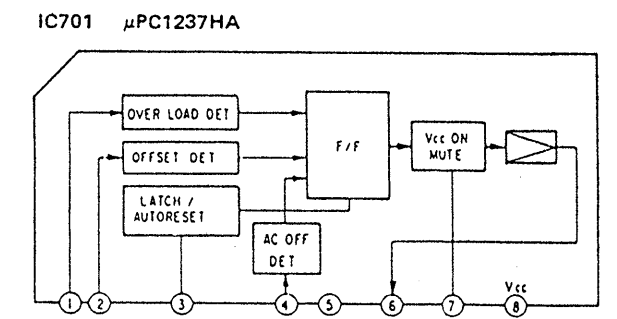
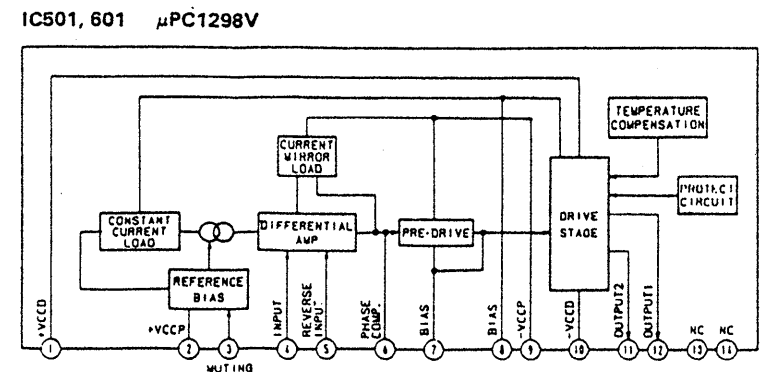

REF	TA-F170				TA-F240
	GERMANY	AEP	UK	E	UK
1	Q502	2SC3855	2SC3854	2SC3854	2SC3855
2	Q503	2SA1491	2SA1490	2SA1490	2SA1491
3	R705	390 1M	390 1M	390 1M	680 1M
4	R704	12k	12k	12k	15k
5	R706	6.8k	8.2k	8.2k	10k
6	R801	120 3W	150 3W	150 3W	390 3W
7	R802	470 3W	560 3W	560 3W	1.5K 3W
8	C807	47	47	47	47
9	C808	50V	50V	50V	63V
10	C801	6800	6800	6800	10000
11	C802	50V	50V	50V	63V
12	C803	470	470	470	470
13	C804	50V	50V	50V	63V
14	F1	1.6A	1.6A	1.6A	2.5A

() : GERMANY ONLY

Note:

- All capacitors are in μF unless otherwise noted. pF : μF 50 WV or less are not indicated except for electrolytics and tantalums.
- All resistors are in Ω and $\frac{1}{4}$ W or less unless otherwise specified.
- \square : nonflammable resistor.

Note:
The components identified by mark Δ or dotted line with mark \triangle are critical for safety. Replace only with part number specified.

Note:
Les composants identifiés par une marque Δ sont critiques pour la sécurité. Ne les remplacer que par une pièce portant le numéro spécifié.

- B+** : B+ Line.
- B-** : B- Line.
- \square : adjustment for repair.
- Voltages and waveforms are dc with respect to ground under no-signal (detuned) conditions.
- Voltages are taken with a VOM (10 M Ω /V). Voltage variations may be noted due to normal production tolerances.
- Signal path.
- \Rightarrow : PHONO

SECTION 5 EXPLODED VIEWS

NOTE:

- -XX and -X mean standardized parts, so they may have some difference from the original one.

- Color Indication of Appearance Parts
Example:
KNOB, BALANCE (WHITE) . . . (RED)

↑ ↑
Parts Color Cabinet's Color

- Items marked "*" are not stocked since they are seldom required for routine service. Some delay should be anticipated when ordering these items.
- The mechanical parts with no reference number in the exploded views are not supplied.
- Hardware (# mark) list is given in the last of this parts list.

The components identified by mark Δ or dotted line with mark Δ are critical for safety. Replace only with part number specified.

Les composants identifiés par une marque Δ sont critiques pour la sécurité. Ne les remplacer que par une pièce portant le numéro spécifié.

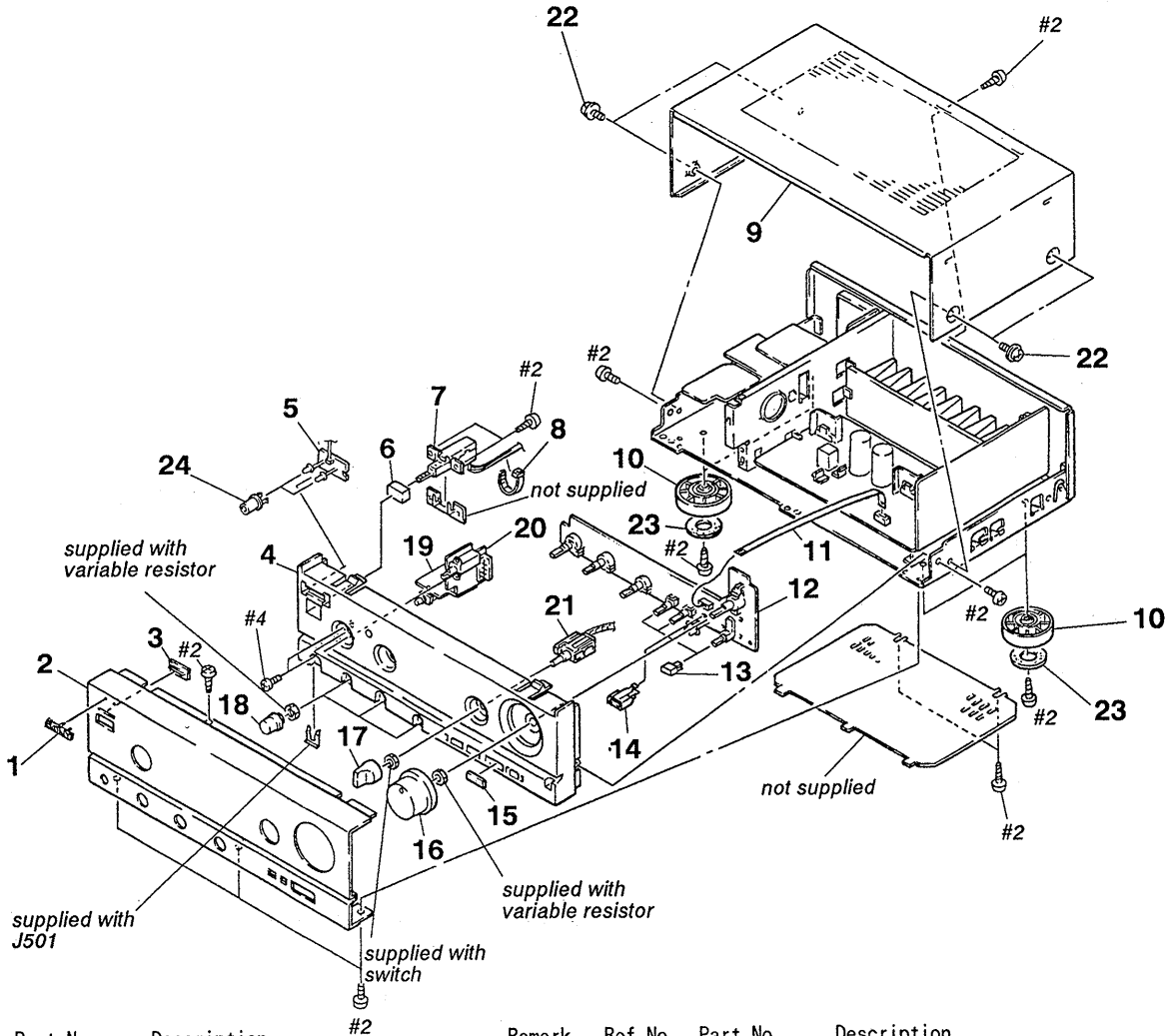

Ref. No.	Part No.	Description	Remark
1	4-908-848-01	EMBLEM, SONY	
2	4-945-182-01	PANEL, FRONT (F170)	
2	4-945-182-11	PANEL, FRONT (F240)	
3	4-945-175-01	INDICATOR (PSW)	
4	* 4-945-181-01	PANEL (BASE), FRONT	
5	* 1-639-817-11	LED BOARD	
6	4-929-289-01	BUTTON	
7	1-553-318-41	SWITCH, PUSH (AC POWER) (1 KEY)	
8	3-655-653-21	BAND (TAITON), BINDING (F170:AEP, UK, GERMANY/F240)	
9	4-929-294-11	CASE	
10	X-3304-938-2	FOOT ASSY.	
11	1-590-036-11	WIRE, FLAT TYPE (13 CORE)	

Ref. No.	Part No.	Description	Remark
12	* A-4345-123-A	PANEL BOARD, COMPLETE (F240)	
12	* A-4345-133-A	PANEL BOARD, COMPLETE (F170)	
13	4-945-176-01	BUTTON (18X11)	
14	4-945-177-01	HOUSE, LIGHTING	
15	4-945-622-01	PLATE (S/D), INDICATION	
16	X-4941-616-1	KNOB (R53) ASSY	
17	4-945-173-01	KNOB (R21)	
18	4-945-174-01	KNOB (F25)	
19	* 1-639-812-11	H. P BOARD	
20	* 1-639-811-11	SP SW BOARD	
21	1-572-803-11	SWITCH, ROTARY SLIDE (INPUT SELECTOR)	
22	3-704-366-01	SCREW (CASE) (M3X8)	
23	4-923-836-11	CUSHION	
24	* 3-362-478-21	HOLDER (T), LED	

REVISED

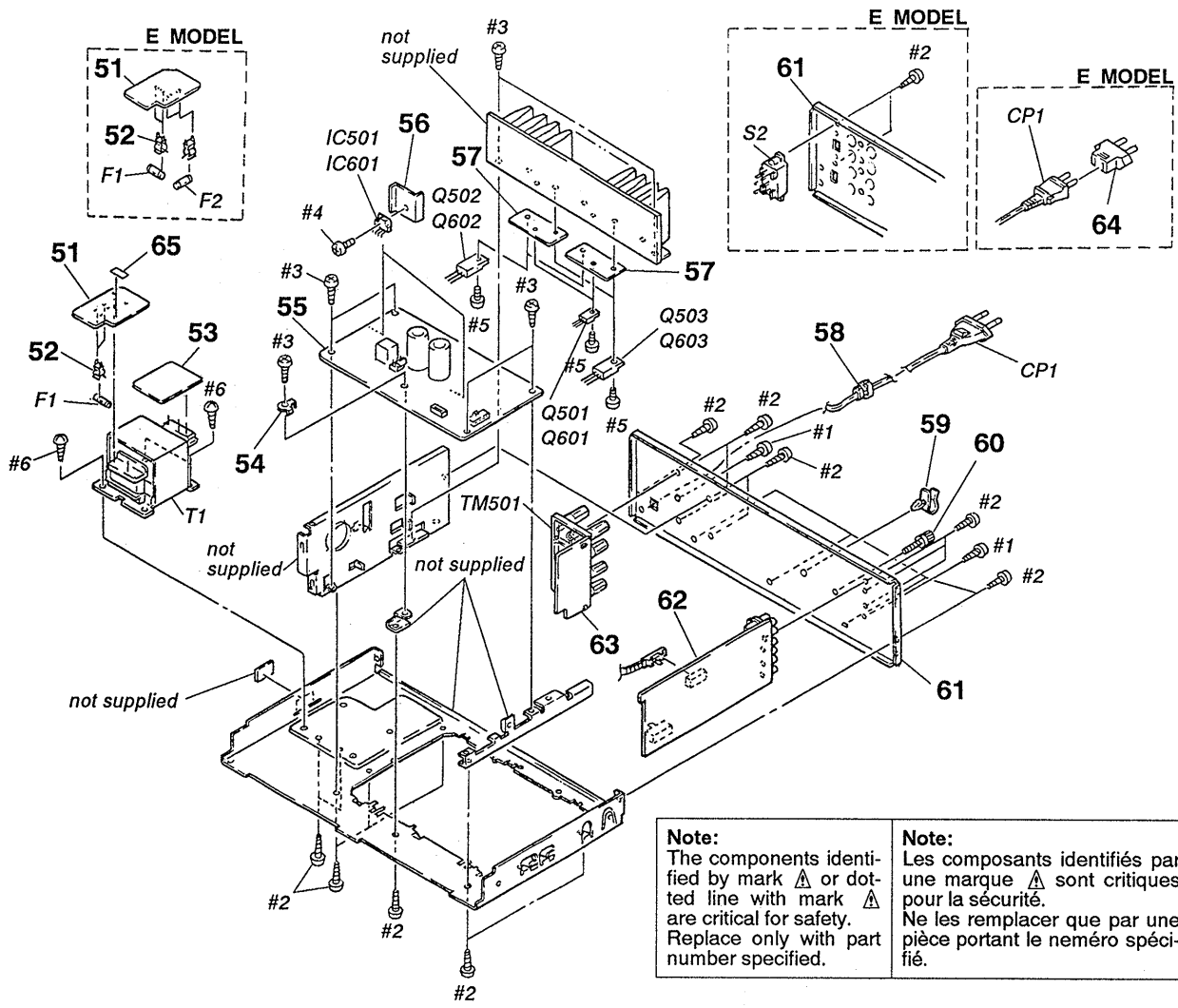

<p>Note: The components identified by mark Δ or dotted line with mark Δ are critical for safety. Replace only with part number specified.</p>	<p>Note: Les composants identifiés par une marque Δ sont critiques pour la sécurité. Ne les remplacer que par une pièce portant le numéro spécifié.</p>
--	--

Ref. No.	Part No.	Description	Remark	Ref. No.	Part No.	Description	Remark
51	* 1-639-816-11	POWER BOARD		61	* 4-944-986-11	PANEL, BACK (F170:AEP)	
52	* 1-533-225-11	HOLDER, FUSE		61	* 4-944-986-21	PANEL, BACK (F170:GERMANY)	
53	* 1-639-818-11	TRANSFORMER BOARD		61	* 4-944-986-31	PANEL, BACK (F170:UK)	
54	* 4-942-204-01	PLATE, GROUND		62	* 1-639-814-11	INPUT BOARD	
55	* A-4345-128-A	MAIN BOARD, COMPLETE (F240)		63	* 1-639-813-11	SP TM BOARD	
55	* A-4345-138-A	MAIN BOARD, COMPLETE (F170:AEP, UK)		64	Δ 1-569-007-11	ADAPTOR, CONVERSION 2P (F170:E)	
55	* A-4345-143-A	MAIN BOARD, COMPLETE (F170:GERMANY)		65	3-701-947-15	LABEL (2.5A), FUSE (F240)	
55	* A-4345-154-A	MAIN BOARD, COMPLETE (F170:E)		CP1	Δ 1-575-651-11	CORD, POWER (AEP, GERMANY)	
56	* 4-931-998-11	HEAT SINK (S) (F170)		CP1	Δ 1-575-652-11	CORD, POWER (UK)	
56	* 4-931-998-21	HEAT SINK (S) (F240)		CP1	Δ 1-575-653-11	CORD, POWER (E)	
57	4-945-480-01	SHEET, INSULATING		F1	Δ 1-532-286-00	FUSE (F240)	
58	* 3-703-571-11	BUSHING (S) (4516), CORD (F170:E)		F1	Δ 1-532-259-00	FUSE (F170)	
58	* 3-703-244-00	BUSHING (2104), CORD		F2	Δ 1-532-259-00	FUSE (F170:E)	
59	* 2-379-614-01	HOOK		S2	Δ 1-570-307-11	SWITCH, VOLTAGE CHANGE (F170:E)	
60	3-706-165-00	SCREW		T1	Δ 1-450-575-11	TRANSFORMER, POWER (F240)	
61	* 4-944-986-41	PANEL, BACK (F170:E)		T1	Δ 1-450-576-11	TRANSFORMER, POWER (F170:AEP)	
61	* 4-944-986-51	PANEL, BACK (F240)		T1	Δ 1-450-577-11	TRANSFORMER, POWER (F170:GERMANY)	
				T1	Δ 1-450-578-11	TRANSFORMER, POWER (F170:UK)	
				T1	Δ 1-450-579-11	TRANSFORMER, POWER (F170:E)	

SECTION 6 ELECTRICAL PARTS LIST

MAIN
SP SW
H. P
SP TM
INPUT

NOTE:

- Due to standardization, replacements in the parts list may be different from the parts specified in the diagrams or the components used on the sets.
- -XX and -X mean standardized parts, so they may have some difference from the original one.
- RESISTORS
All resistors are in ohms.
METAL: Metal-film resistor
METAL OXIDE: Metal Oxide-film resistor
F: nonflammable
- Items marked "*" are not stocked since they are seldom required for routine service. Some delay should be anticipated when ordering these items.
- SEMICONDUCTORS
In each case, u: μ , for example:
uA...: μ A..., uPA...: μ PA...,
uPB...: μ PB..., uPC...: μ PC...,
uPD...: μ PD...
- CAPACITORS
uF: μ F
- COILS
uH: μ H

The components identified by mark Δ or dotted line with mark Δ are critical for safety. Replace only with part number specified.

Les composants identifiés par une marque Δ sont critiques pour la sécurité. Ne les remplacer que par une pièce portant le numéro spécifié.

When including parts by reference number, please include the board name.

Ref. No.	Part No.	Description	Remark	Ref. No.	Part No.	Description	Remark
	* A-4345-128-A	MAIN BOARD, COMPLETE (F240)		C503	1-102-316-00	CERAMIC	15PF 5% 500V
	* A-4345-138-A	MAIN BOARD, COMPLETE (F170:AEP, UK)		C504	1-126-022-11	ELECT	47uF 20% 16V
	* A-4345-143-A	MAIN BOARD, COMPLETE (F170:GERMANY)		C505	1-136-163-00	FILM	0.068uF 5% 50V
	* A-4345-154-A	MAIN BOARD, COMPLETE (F170:E)		C506	1-136-163-00	FILM	0.068uF 5% 50V
	*****			C507	1-136-163-00	FILM	0.068uF 5% 50V
	* 1-639-811-11	SP SW BOARD		C508	1-136-157-00	FILM	0.022uF 5% 50V
	*****						(F170:GERMANY)
	* 1-639-812-11	H. P. BOARD		C509	1-136-157-00	FILM	0.022uF 5% 50V
	*****						(F170:GERMANY)
	* 1-639-813-11	SP TM BOARD		C510	1-136-157-00	FILM	0.022uF 5% 50V
	*****						(F170:GERMANY)
	* 1-639-814-11	INPUT BOARD		C511	1-136-157-00	FILM	0.022uF 5% 50V
	*****						(F170:GERMANY)
	* 4-931-998-11	HEAT SINK (S) (F170)		C512	1-136-157-00	FILM	0.022uF 5% 50V
	* 4-931-998-21	HEAT SINK (S) (F240)					(F170:GERMANY)
	* 4-942-204-01	PLATE, GROUND		C513	1-162-217-11	CERAMIC	56PF
	7-682-548-04	SCREW +BVT7 3X8 (S)					(F170:GERMANY)
	< CAPACITOR >			C601	1-126-163-11	ELECT	4.7uF 20% 50V
C101	1-162-286-31	CERAMIC	220PF 10% 50V (F170:GERMANY)	C602	1-126-023-11	ELECT	100uF 20% 25V
C102	1-162-286-31	CERAMIC	220PF 10% 50V (F170:GERMANY)	C603	1-102-316-00	CERAMIC	15PF 5% 500V
C103	1-162-286-31	CERAMIC	220PF 10% 50V (F170:GERMANY)	C604	1-126-022-11	ELECT	47uF 20% 16V
C104	1-162-286-31	CERAMIC	220PF 10% 50V (F170:GERMANY)	C605	1-136-163-00	FILM	0.068uF 5% 50V
C105	1-162-286-31	CERAMIC	220PF 10% 50V (F170:GERMANY)	C606	1-136-163-00	FILM	0.068uF 5% 50V
C106	1-164-075-11	CERAMIC	150PF 10% 50V	C607	1-136-163-00	FILM	0.068uF 5% 50V
C107	1-164-070-11	CERAMIC	100PF 5% 50V (F170:GERMANY)	C608	1-136-157-00	FILM	0.022uF 5% 50V
C108	1-126-163-11	ELECT	4.7uF 20% 50V				(F170:GERMANY)
C109	1-164-075-11	CERAMIC	150PF 10% 50V	C609	1-136-157-00	FILM	0.022uF 5% 50V
C110	1-126-051-11	ELECT	47uF 20% 50V				(F170:GERMANY)
C111	1-130-480-00	MYLAR	0.0056uF 5% 50V	C610	1-136-157-00	FILM	0.022uF 5% 50V
C112	1-130-473-00	MYLAR	0.0015uF 5% 50V				(F170:GERMANY)
C113	1-126-163-11	ELECT	4.7uF 20% 50V	C611	1-136-157-00	FILM	0.022uF 5% 50V
C120	1-126-022-11	ELECT	47uF 20% 16V				(F170:GERMANY)
C201	1-162-286-31	CERAMIC	220PF 10% 50V (F170:GERMANY)	C612	1-136-157-00	FILM	0.022uF 5% 50V
							(F170:GERMANY)
C202	1-162-286-31	CERAMIC	220PF 10% 50V (F170:GERMANY)	C613	1-162-217-11	CERAMIC	56PF
							(F170:GERMANY)
C203	1-162-286-31	CERAMIC	220PF 10% 50V (F170:GERMANY)	C702	1-124-982-81	ELECT	220uF 20% 6.3V
				C703	1-126-059-11	ELECT	10uF 20% 50V
C204	1-162-286-31	CERAMIC	220PF 10% 50V (F170:GERMANY)	C704	1-124-994-11	ELECT	100uF 20% 10V
				C705	1-126-022-11	ELECT	47uF 20% 16V
C205	1-162-286-31	CERAMIC	220PF 10% 50V (F170:GERMANY)	C706	1-126-059-11	ELECT	10uF 20% 50V
							(F170:GERMANY)
C206	1-164-075-11	CERAMIC	150PF 10% 50V	C801	1-125-686-11	ELECT	6800uF 20% 50V (F170)
C207	1-164-070-11	CERAMIC	100PF 5% 50V (F170:GERMANY)	C801	1-128-342-11	ELECT	10000uF 20% 63V (F240)
C208	1-126-163-11	ELECT	4.7uF 20% 50V				(F170:GERMANY)
C209	1-164-075-11	CERAMIC	150PF 10% 50V	C802	1-125-686-11	ELECT	6800uF 20% 50V (F170)
C210	1-126-051-11	ELECT	47uF 20% 50V	C802	1-128-342-11	ELECT	10000uF 20% 63V (F240)
C211	1-130-480-00	MYLAR	0.0056uF 5% 50V				(F170:GERMANY)
C212	1-130-473-00	MYLAR	0.0015uF 5% 50V	C803	1-124-921-11	ELECT	470uF 20% 63V (F240)
C213	1-126-163-11	ELECT	4.7uF 20% 50V	C803	1-126-055-11	ELECT	470uF 20% 50V (F170)
C220	1-126-022-11	ELECT	47uF 20% 16V				(F170:GERMANY)
C501	1-126-163-11	ELECT	4.7uF 20% 50V	C804	1-124-921-11	ELECT	470uF 20% 63V (F240)
C502	1-126-023-11	ELECT	100uF 20% 25V	C804	1-126-055-11	ELECT	470uF 20% 50V (F170)
							(F170:GERMANY)
				C805	1-124-916-11	ELECT	22uF 20% 63V (F240)
				C805	1-126-049-11	ELECT	22uF 20% 50V (F170)
							(F170:GERMANY)
				C806	1-124-916-11	ELECT	22uF 20% 63V (F240)
				C806	1-126-049-11	ELECT	22uF 20% 50V (F170)

MAIN

SP SW

H. P

SP TM

INPUT

Ref. No.	Part No.	Description	Remark	Ref. No.	Part No.	Description	Remark
C807	1-126-051-11	ELECT	47uF 20% 50V (F170)			< COIL >	
C807	1-126-062-11	ELECT	47uF 20% 63V (F240)				
C808	1-126-051-11	ELECT	47uF 20% 50V (F170)	L501	* 1-420-872-00	COIL, AIR CORE	
C808	1-126-062-11	ELECT	47uF 20% 63V (F240)	L601	* 1-420-872-00	COIL, AIR CORE	
C809	1-106-375-12	MYLAR	0.022uF 5% 200V			< TRANSISTOR >	
C810	1-126-104-11	ELECT	470uF 20% 35V	Q501	8-729-209-15	TRANSISTOR 2SD2012	
C811	1-126-104-11	ELECT	470uF 20% 35V	Q502	8-729-320-83	TRANSISTOR 2SC3855-0Y	(F170:GERMANY/F240)
C812	1-126-023-11	ELECT	100uF 20% 25V	Q502	8-729-321-96	TRANSISTOR 2SC3854-0Y	(F170:AEP, UK, E)
C813	1-126-023-11	ELECT	100uF 20% 25V	Q503	8-729-320-86	TRANSISTOR 2SA1491-0Y	(F170:GERMANY/F240)
C814	1-106-375-12	MYLAR	0.022uF 5% 200V	Q503	8-729-322-02	TRANSISTOR 2SA1490-OPY	(F170:AEP, UK, E)
		< CONNECTOR >		Q504	8-729-140-84	TRANSISTOR 2SC1841TP-PAFAEA	
CN501	* 1-568-832-11	SOCKET, CONNECTOR 13P		Q601	8-729-209-15	TRANSISTOR 2SD2012	
CNJ101	* 1-566-883-61	JACK, PIN 6P		Q602	8-729-320-83	TRANSISTOR 2SC3855-0Y	(F170:GERMANY/F240)
CNJ102	* 1-566-883-51	JACK, PIN 6P		Q602	8-729-321-96	TRANSISTOR 2SC3854-0Y	(F170:AEP, UK, E)
CNJ103	? 1-573-299-11	CONNECTOR, BOARD TO BOARD 10P		Q603	8-729-320-86	TRANSISTOR 2SA1491-0Y	(F170:GERMANY/F240)
CNP301	? 1-573-296-11	CONNECTOR, BOARD TO BOARD 10P		Q603	8-729-322-02	TRANSISTOR 2SA1490-OPY	(F170:AEP, UK, E)
CNP502	* 1-564-243-00	PIN, CONNECTOR 6P		Q604	8-729-140-84	TRANSISTOR 2SC1841TP-PAFAEA	
CNP503	* 1-506-599-11	PIN, CONNECTOR 10P		Q701	8-729-900-63	TRANSISTOR DTA124ES	
CNP505	* 1-564-241-00	PIN, CONNECTOR 4P		Q801	8-729-111-55	TRANSISTOR 2SD1312-K	
CNP801	* 1-564-104-00	PIN, CONNECTOR 3P		Q802	8-729-924-90	TRANSISTOR 2SB1370-EF	
		< DIODE >		Q901	8-729-620-05	TRANSISTOR 2SC2603-EF	
D501	8-719-912-20	DIODE 1SS120				< RESISTOR >	
D502	8-719-912-20	DIODE 1SS120		R101	1-249-417-11	CARBON 1K 5% 1/4W	
D601	8-719-912-20	DIODE 1SS120		R102	1-249-413-11	CARBON 470 5% 1/4W (F170:GERMANY)	
D602	8-719-912-20	DIODE 1SS120		R103	1-249-413-11	CARBON 470 5% 1/4W (F170:GERMANY)	
D701	8-719-912-20	DIODE 1SS120		R104	1-249-413-11	CARBON 470 5% 1/4W (F170:GERMANY)	
D702	8-719-912-20	DIODE 1SS120		R105	1-249-413-11	CARBON 470 5% 1/4W (F170:GERMANY)	
D703	8-719-200-77	DIODE 10E2N		R106	1-249-417-11	CARBON 1K 5% 1/4W	
D801	8-719-302-38	DIODE RBV-602-01		R107	1-247-903-00	CARBON 1M 5% 1/4W	
D802	8-719-200-77	DIODE 10E2N		R108	1-247-903-00	CARBON 1M 5% 1/4W	
D803	8-719-200-77	DIODE 10E2N		R109	1-247-903-00	CARBON 1M 5% 1/4W	
D804	8-719-200-77	DIODE 10E2N		R110	1-247-903-00	CARBON 1M 5% 1/4W	
D805	8-719-200-77	DIODE 10E2N		R111	1-249-441-11	CARBON 100K 5% 1/4W	
		< IC >		R112	1-249-418-11	CARBON 1.2K 5% 1/4W (F170:GERMANY)	
IC101	8-759-636-74	IC M5218AP-22		R113	1-249-441-11	CARBON 100K 5% 1/4W	
IC501	8-759-109-06	IC uPC1298V (F170)		R114	1-249-416-11	CARBON 820 5% 1/4W	
IC501	8-759-144-04	IC uPC1342V (F240)		R115	1-247-897-11	CARBON 560K 5% 1/4W	
IC601	8-759-109-06	IC uPC1298V (F170)		R116	1-249-437-11	CARBON 47K 5% 1/4W	
IC601	8-759-144-04	IC uPC1342V (F240)		R117	1-249-409-11	CARBON 220 5% 1/4W	
IC701	8-759-111-68	IC uPC1237HA		R118	1-249-441-11	CARBON 100K 5% 1/4W	
IC801	8-759-231-59	IC TA7815S		R201	1-249-417-11	CARBON 1K 5% 1/4W	
IC802	8-759-245-87	IC TA7915S		R202	1-249-413-11	CARBON 470 5% 1/4W (F170:GERMANY)	
		< JACK >		R203	1-249-413-11	CARBON 470 5% 1/4W (F170:GERMANY)	
J501	1-507-796-71	JACK (HEADPHONES)		R204	1-249-413-11	CARBON 470 5% 1/4W (F170:GERMANY)	
				R205	1-249-413-11	CARBON 470 5% 1/4W (F170:GERMANY)	
				R206	1-249-417-11	CARBON 1K 5% 1/4W	

MAIN

SP SW

H. P

SP TM

INPUT

PANEL

Note:
The components identified by mark Δ or dotted line with mark Δ are critical for safety. Replace only with part number specified.

Note:
Les composants identifiés par une marque Δ sont critiques pour la sécurité. Ne les remplacer que par une pièce portant le numéro spécifié.

Ref. No.	Part No.	Description	Remark	Ref. No.	Part No.	Description	Remark
R207	1-247-903-00	CARBON	1M 5% 1/4W	R620	1-247-745-11	CARBON	330 5% 1/2W
R208	1-247-903-00	CARBON	1M 5% 1/4W	R621	1-247-745-11	CARBON	330 5% 1/2W
R209	1-247-903-00	CARBON	1M 5% 1/4W	R701	1-249-427-11	CARBON	6.8K 5% 1/4W
R210	1-247-903-00	CARBON	1M 5% 1/4W	R702	1-249-441-11	CARBON	100K 5% 1/4W
R211	1-249-441-11	CARBON	100K 5% 1/4W	R703	1-249-439-11	CARBON	68K 5% 1/4W
R212	1-249-418-11	CARBON	1.2K 5% 1/4W (F170:GERMANY)	R704	1-249-430-11	CARBON	12K 5% 1/4W (F170)
R213	1-249-441-11	CARBON	100K 5% 1/4W	R704	1-249-431-11	CARBON	15K 5% 1/4W (F240)
R214	1-249-416-11	CARBON	820 5% 1/4W	R705 Δ	1-215-868-00	METAL OXIDE	680 5% 1W F (F240)
R215	1-247-897-11	CARBON	560K 5% 1/4W	R705 Δ	1-216-430-11	METAL OXIDE	390 5% 1W F (F170)
R216	1-249-437-11	CARBON	47K 5% 1/4W	R706	1-249-427-11	CARBON	6.8K 5% 1/4W (F170:GERMANY)
R217	1-249-409-11	CARBON	220 5% 1/4W	R706	1-249-428-11	CARBON	8.2K 5% 1/4W (F170:AEP, UK, E)
R218	1-249-441-11	CARBON	100K 5% 1/4W	R706	1-249-429-11	CARBON	10K 5% 1/4W (F240)
R501	1-249-417-11	CARBON	1K 5% 1/4W	R801 Δ	1-215-912-11	METAL OXIDE	150 5% 3W F (F170:AEP, UK, E)
R502	1-249-438-11	CARBON	56K 5% 1/4W	R801 Δ	1-216-475-11	METAL OXIDE	120 5% 3W F (F170:GERMANY)
R503	1-249-412-11	CARBON	390 5% 1/4W	R801 Δ	1-216-478-11	METAL OXIDE	390 5% 3W F (F240)
R504	1-249-466-11	CARBON	56K 5% 1/4W	R802 Δ	1-215-915-11	METAL OXIDE	470 5% 3W F (F170:GERMANY)
R505	1-249-423-11	CARBON	3.3K 5% 1/4W	R802 Δ	1-215-918-00	METAL OXIDE	1.5K 5% 3W F (F240)
R506	1-249-419-11	CARBON	1.5K 5% 1/4W	R802 Δ	1-216-479-11	METAL OXIDE	560 5% 3W F (F170:AEP, UK, E)
R508	1-247-688-11	CARBON	10 5% 1/4W	R805	1-249-417-11	CARBON	1K 5% 1/4W
R509	1-247-688-11	CARBON	10 5% 1/4W	R806	1-249-417-11	CARBON	1K 5% 1/4W
R510 Δ	1-216-361-00	METAL OXIDE	0.22 5% 2W F (F170)	R901	1-249-417-11	CARBON	1K 5% 1/4W
R510 Δ	1-217-611-00	METAL OXIDE	0.1 10% 2W F (F240)			< VARIABLE RESISTOR >	
R511 Δ	1-216-361-00	METAL OXIDE	0.22 5% 2W F (F170)	RV501	1-238-596-11	RES. ADJ. CARBON	470
R511 Δ	1-217-611-00	METAL OXIDE	0.1 10% 2W F (F240)	RV601	1-238-596-11	RES. ADJ. CARBON	470
R512	1-247-713-11	CARBON	1K 5% 1/4W			< RELAY >	
R513	1-249-427-11	CARBON	6.8K 5% 1/4W	RY701	1-515-501-00	RELAY	
R514	1-247-727-11	CARBON	10 5% 1/2W			< SWITCH >	
R515	1-247-727-11	CARBON	10 5% 1/2W	S303	1-572-804-11	SWITCH, SLIDE (INPUT SELECTOR)	
R516	1-247-887-00	CARBON	220K 5% 1/4W	S501	1-571-973-11	SWITCH, ROTARY (SPEAKERS)	
R517	1-249-431-11	CARBON	15K 5% 1/4W			< TERMINAL >	
R518	1-247-727-11	CARBON	10 5% 1/2W (F170:GERMANY)	TM501	1-537-227-11	TERMINAL BOARD (SP) (F170:AEP)	
R519	1-247-727-11	CARBON	10 5% 1/2W (F170:GERMANY)	TM501	1-537-228-11	TERMINAL BOARD (SP) (F170:GERMANY)	
R520	1-247-745-11	CARBON	330 5% 1/2W	TM501	1-537-235-11	TERMINAL BOARD (SP) (F170:UK, E/F240)	
R521	1-247-745-11	CARBON	330 5% 1/2W	TM801	1-808-881-91	THERMISTOR (POSITIVE) 2.2	
R601	1-249-417-11	CARBON	1K 5% 1/4W	TM802	1-808-881-91	THERMISTOR (POSITIVE) 2.2	
R602	1-249-438-11	CARBON	56K 5% 1/4W			*****	
R603	1-249-412-11	CARBON	390 5% 1/4W			* A-4345-123-A PANEL BOARD, COMPLETE (F240)	
R604	1-249-466-11	CARBON	56K 5% 1/4W			* A-4345-133-A PANEL BOARD, COMPLETE (F170)	
R605	1-249-423-11	CARBON	3.3K 5% 1/4W			*****	
R606	1-249-419-11	CARBON	1.5K 5% 1/4W				
R608	1-247-688-11	CARBON	10 5% 1/4W				
R609	1-247-688-11	CARBON	10 5% 1/4W				
R610 Δ	1-216-361-00	METAL OXIDE	0.22 5% 2W F (F170)				
R610 Δ	1-217-611-00	METAL OXIDE	0.1 10% 2W F (F240)				
R611 Δ	1-216-361-00	METAL OXIDE	0.22 5% 2W F (F170)				
R611 Δ	1-217-611-00	METAL OXIDE	0.1 10% 2W F (F240)				
R612	1-247-713-11	CARBON	1K 5% 1/4W				
R613	1-249-427-11	CARBON	6.8K 5% 1/4W				
R614	1-247-727-11	CARBON	10 5% 1/2W				
R615	1-247-727-11	CARBON	10 5% 1/2W				
R616	1-247-887-00	CARBON	220K 5% 1/4W				
R617	1-249-431-11	CARBON	15K 5% 1/4W				
R618	1-247-727-11	CARBON	10 5% 1/2W (F170:GERMANY)				
R619	1-247-727-11	CARBON	10 5% 1/2W (F170:GERMANY)				

Note:
The components identified by mark Δ or dotted line with mark Δ are critical for safety. Replace only with part number specified.

Note:
Les composants identifiés par une marque Δ sont critiques pour la sécurité. Ne les remplacer que par une pièce portant le numéro spécifié.

PANEL

POWER

LED

TRANSFORMER

Ref. No.	Part No.	Description	Remark	Ref. No.	Part No.	Description	Remark
* 1-639-816-11		POWER BOARD				< IC >	

* 1-639-817-11		LED BOARD		IC301	8-759-634-50	IC M5218AL	

* 1-639-818-11		TRANSFORMER BOARD				< RESISTOR >	

1-533-225-11		HOLDER, FUSE		R119	1-249-405-11	CARBON 100 5% 1/4W	
* 1-564-214-11		PIN, CONNECTOR 3P		R219	1-249-405-11	CARBON 100 5% 1/4W	
* 3-362-478-21		HOLDER (T), LED		R301	1-249-417-11	CARBON 1K 5% 1/4W	
				R302	1-249-417-11	CARBON 1K 5% 1/4W	
		< CAPACITOR >		R303	1-249-423-11	CARBON 3.3K 5% 1/4W	
C1 Δ 1-161-744-00		CERAMIC 0.01uF 400V		R304	1-249-442-11	CARBON 510 5% 1/4W	
C301	1-126-163-11	ELECT 4.7uF 20% 50V		R305	1-249-442-11	CARBON 510 5% 1/4W	
C302	1-162-217-31	CERAMIC 56PF 5% 50V		R306	1-249-408-11	CARBON 180 5% 1/4W	
C303	1-126-163-11	ELECT 4.7uF 20% 50V		R307	1-247-903-00	CARBON 1M 5% 1/4W	
C304	1-136-155-00	FILM 0.015uF 5% 50V		R308	1-247-903-00	CARBON 1M 5% 1/4W	
C305	1-136-161-00	FILM 0.047uF 5% 50V		R309	1-249-422-11	CARBON 2.7K 5% 1/4W	
C306	1-136-169-00	FILM 0.22uF 5% 50V		R310	1-247-830-11	CARBON 910 5% 1/4W	
C307	1-136-175-00	FILM 0.68uF 5% 50V		R311	1-249-441-11	CARBON 100K 5% 1/4W	
C309	1-162-286-31	CERAMIC 220PF 10% 50V		R312	1-249-429-11	CARBON 10K 5% 1/4W	
C310	1-136-161-00	FILM 0.047uF 5% 50V		R313	1-249-429-11	CARBON 10K 5% 1/4W	
C311	1-126-022-11	ELECT 47uF 20% 16V		R314	1-247-903-00	CARBON 1M 5% 1/4W	
C401	1-126-163-11	ELECT 4.7uF 20% 50V		R401	1-249-417-11	CARBON 1K 5% 1/4W	
C402	1-162-217-31	CERAMIC 56PF 5% 50V		R402	1-249-417-11	CARBON 1K 5% 1/4W	
C403	1-126-163-11	ELECT 4.7uF 20% 50V		R403	1-249-423-11	CARBON 3.3K 5% 1/4W	
C404	1-136-155-00	FILM 0.015uF 5% 50V		R404	1-249-442-11	CARBON 510 5% 1/4W	
C405	1-136-161-00	FILM 0.047uF 5% 50V		R405	1-249-442-11	CARBON 510 5% 1/4W	
C406	1-136-169-00	FILM 0.22uF 5% 50V		R406	1-249-408-11	CARBON 180 5% 1/4W	
C407	1-136-175-00	FILM 0.68uF 5% 50V		R407	1-247-903-00	CARBON 1M 5% 1/4W	
C409	1-162-286-31	CERAMIC 220PF 10% 50V		R408	1-247-903-00	CARBON 1M 5% 1/4W	
C410	1-136-161-00	FILM 0.047uF 5% 50V		R409	1-249-422-11	CARBON 2.7K 5% 1/4W	
C411	1-126-022-11	ELECT 47uF 20% 16V		R410	1-247-830-11	CARBON 910 5% 1/4W	
		< CONNECTOR >		R411	1-249-441-11	CARBON 100K 5% 1/4W	
CN301	* 1-568-832-11	SOCKET, CONNECTOR 13P		R412	1-249-429-11	CARBON 10K 5% 1/4W	
CNP2	* 1-564-321-00	PIN, CONNECTOR 2P		R413	1-249-429-11	CARBON 10K 5% 1/4W	
CNP3	* 1-564-321-00	PIN, CONNECTOR 2P		R414	1-247-903-00	CARBON 1M 5% 1/4W	
CNP4	* 1-564-321-00	PIN, CONNECTOR 2P (F170:E)		R902	1-247-747-11	CARBON 470 5% 1/2W	
CNP5	* 1-564-687-11	PIN, CONNECTOR 3P (F170:E)		R903	1-247-749-11	CARBON 560 5% 1/2W	
		< CORD, POWER >				< VARIABLE RESISTOR >	
CP1 Δ 1-575-651-11		CORD, POWER (AEP, GERMANY)		RV301	1-238-513-11	RES, VAR, CARBON 150K/150K (BALANCE)	
CP1 Δ 1-575-652-11		CORD, POWER (UK)		RV302	1-241-548-11	RES, VAR, CARBON 10K (TREBLE)	
CP1 Δ 1-575-653-11		CORD, POWER (E)		RV303	1-241-549-11	RES, VAR, CARBON 10K (BASS)	
		< DIODE >		RV304	1-241-550-11	RES, VAR, CARBON 120K/120K (VOLUME)	
D901	8-719-303-00	DIODE SEL2510C-C				< SWITCH >	
D902	8-719-303-00	DIODE SEL2510C-C		S1	1-553-318-11	SWITCH, PUSH (1 KEY) (POWER)	
D904	8-719-301-52	DIODE SEL2810A-C		S2 Δ 1-570-307-11		SWITCH (VOLTAGE SELECTOT) (F170:E)	
D905	8-719-301-52	DIODE SEL2810A-C		S301	1-571-112-21	SWITCH, PUSH (1 KEY) (LOUDNESS)	
		< FUSE >		S302	1-572-642-11	SWITCH, PUSH (1 KEY) (SOURCE DIRECT)	
F1 Δ 1-532-286-00		FUSE TIME-LAG 2.5A (F240)		S304	1-571-872-11	SWITCH, PUSH (1 KEY) (TAPE/DAT MONITOR)	
F1 Δ 1-532-259-00		FUSE TIME-LAG 1.6A (F170)				< TRANSFORMER >	
F2 Δ 1-532-259-00		FUSE TIME-LAG 1.6A (F170:E)		T1 Δ 1-450-575-11		TRANSFORMER, POWER (F240)	
				T1 Δ 1-450-576-11		TRANSFORMER, POWER (F170:AEP)	
				T1 Δ 1-450-577-11		TRANSFORMER, POWER (F170:GERMANY)	

PANEL **POWER** **LED** **TRANSFORMER**

Ref. No.	Part No.	Description	Remark
T1	△· 1-450-578-11	TRANSFORMER, POWER (F170:UK)	
T1	△· 1-450-579-11	TRANSFORMER, POWER (F170:E)	

MISCELLANEOUS

7	1-553-318-41	SWITCH, PUSH (AC POWER) (1 KEY)	
11	1-590-036-11	WIRE, FLAT TYPE (13 CORE)	
21	1-572-803-11	SWITCH, ROTARY SLIDE (INPUT SELECTOR)	
64	△· 1-569-007-11	ADAPTOR, CONVERSION 2P (F170:E)	

ACCESSORY & PACKING MATERIAL

- * 3-704-343-01 SHEET (STANDARD), PROTECTION (F240)
- 3-753-389-11 MANUAL, INSTRUCTION (ENGLISH, FRENCH, SPANISH, PORTUGUESE) (AEP, UK, E, GERMANY)
- 3-753-389-41 MANUAL, INSTRUCTION (GERMAN, DUTCH, SWEDISH, ITALIAN) (AEP)
- * 4-944-050-01 INDIVIDUAL CARTON
- * 4-945-810-01 CUSHION (LEFT) (F240)
- * 4-945-811-01 CUSHION (RIGHT) (F240)

HARDWARE LIST

# 1	7-621-849-00	SCREW (BV/RING)	
# 2	7-685-646-79	SCREW +BVTP 3X8 TYPE2 N-S	
# 3	7-685-647-79	SCREW +BVTP 3X10 TYPE2 N-S	
# 4	7-682-548-04	SCREW +BVTT 3X8 (S)	
# 5	7-682-549-04	SCREW +BVTT 3X10 (S)	
# 6	7-682-560-04	SCREW +BVTT 4X6 (S)	

<p>Note: The components identified by mark △ or dotted line with mark △ are critical for safety. Replace only with part number specified.</p>	<p>Note: Les composants identifiés par une marque △ sont critiques pour la sécurité. Ne les remplacer que par une pièce portant le numéro spécifié.</p>
--	--