

TA-F3000/F3000ES

SERVICE MANUAL

AEP Model
UK Model

TA-F3000ES

E Model
Chinese Model

TA-F3000



Photo: TA-F3000

SPECIFICATIONS

System

Power Amplifier: Pure-complementary SEPP MOS FET
Preamplifier: Low-noise, high-gain equalizer amplifier
Power section: Large capacity power supply advanced STD

Rated output

4 ohms, 60 W + 60 W (DIN)
8 ohms, 40 W + 40 W (DIN)
at 4 ohms, 20 Hz to 20 kHz, harmonic distortion 0.04 %
50 W + 50 W
at 6 ohms, 20 Hz to 20 kHz, harmonic distortion 0.03 %
45 W + 45 W
at 8 ohms, 20 Hz to 20 kHz, harmonic distortion 0.02 %
35 W + 35 W

Speaker impedance

4 to 16 ohms

Power bandwidth

10 Hz to 100 kHz (at 30 W output,
harmonic distortion 0.08 %)

Total harmonic distortion

0.008 % (at 8 ohms, 10 W output)

Damping factor

at 1 kHz, 8 ohms 150

Intermodulation distortion (60 Hz : 7 kHz = 4 : 1)

at 8 ohms, 10 W output

0.008 %

Slew rate

125 V/ μ sec

250 V/ μ sec (Inside)

Residual noise

network A 80 μ V

Equalizer deviation

PHONO MM 20 Hz to 20 kHz, ± 0.2 dB

Frequency response

TUNER, CD, AUX, TAPE, MD: 5 Hz to
100 kHz $_{-3}^{+0}$ dB

Input sensitivity and impedance

PHONO MC: 0.18 mV, 100 ohms

PHONO MM: 2.5 mV, 50 kilohms

TUNER, CD, AUX, TAPE, MD:
150 mV, 20 kilohms

S/N

PHONO MC: 75 dB (A Fil, 0.5 mV)

PHONO MM: 85 dB (A Fil, 5 mV)

TUNER, CD, AUX, TAPE, MD: 100 dB
(input short)

Outputs

Output level/impedance MD REC OUT, TAPE REC OUT:
150 mV, 1 kilohm

Phones output

Corresponding to Low/High
impedance headphones: 10 mW
(8 ohms)

Tonecontrols

BASS (100 Hz): ± 7 dB
TREBLE (10 kHz): ± 7 dB

General

Power requirements 230 V, 50/60 Hz

Power consumption

130 W

AC outlets

2 switched + 1 unswitched, total 100 W

Dimensions (approx.) (w/h/d)

280 \times 130 \times 400 mm
(11 $\frac{1}{8}$ \times 5 $\frac{1}{8}$ \times 15 $\frac{3}{4}$ in.) incl.
projecting parts

Mass (approx.)

9.0 kg (19 lbs 14 oz)

Supplied accessories

Shorting plugs* (2)
Remote commander (remote) (1)
Sony SUM-3 (NS) batteries (2)
* plugged into the PHONO jacks when
shipped from the factory

Design and specifications are subject to change without notice.

INTEGRATED STEREO AMPLIFIER

SONY®



TABLE OF CONTENTS

1. GENERAL	3
2. ELECTRICAL ADJUSTMENTS	4
3. DIAGRAMS	
3-1. Circuit Boards Location	4
3-2. Schematic Diagram — Main Section —	5
3-3. Printed Wiring Board — Main Section —	7
3-4. Schematic Diagram — Panel Section —	9
3-5. Printed Wiring Board — Panel Section —	11
3-6. IC Block Diagrams	13
3-7. IC Pin Function	14
4. EXPLODED VIEWS	
4-1. Front Panel Section	15
4-2. Chassis Section	16
5. ELECTRICAL PARTS LIST	17

Notes on chip component replacement

- Never reuse a disconnected chip component.
- Notice that the minus side of a tantalum capacitor may be damaged by heat.

Flexible Circuit Board Repairing

- Keep the temperature of soldering iron around 270°C during repairing.
- Do not touch the soldering iron on the same conductor of the circuit board (within 3 times).
- Be careful not to apply force on the conductor when soldering or unsoldering.

SAFETY-RELATED COMPONENT WARNING !!

COMPONENTS IDENTIFIED BY MARK \triangle OR DOTTED LINE WITH MARK \triangle ON THE SCHEMATIC DIAGRAMS AND IN THE PARTS LIST ARE CRITICAL TO SAFE OPERATION. REPLACE THESE COMPONENTS WITH SONY PARTS WHOSE PART NUMBERS APPEAR AS SHOWN IN THIS MANUAL OR IN SUPPLEMENTS PUBLISHED BY SONY.

Additional Information

Front and Rear Panel Descriptions

Refer to the pages in parenthesis for details.

Front panel

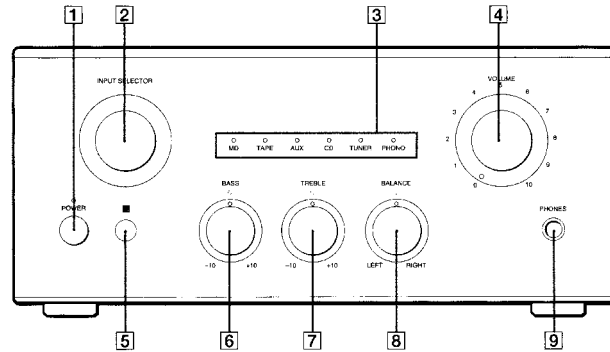

- | | |
|----------------------------------|---------------|
| 1 POWER (8) | 6 BASS (9) |
| 2 INPUT SELECTOR (8, 10) | 7 TREBLE (9) |
| 3 Input source indicator (8, 10) | 8 BALANCE (9) |
| 4 VOLUME (9) | 9 PHONES (9) |
| 5 Remote sensor (4) | |

Rear panel

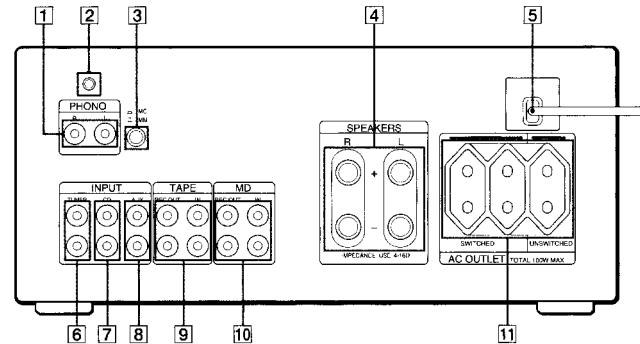

- | | |
|--------------------------------------|------------------|
| 1 PHONO (5) | 7 CD (5) |
| 2 \varnothing ground terminal (5) | 8 AUX (5) |
| 3 PHONO switch (MC/ Ω MM) (5) | 9 TAPE (5) |
| 4 SPEAKERS (6) | 10 MD (5) |
| 5 Mains lead (7) | 11 AC OUTLET (7) |
| 6 TUNER (5) | |

Bias Adjustment

1. Rotate the semi-fixed resistors (RV501, RV601) for bias adjustment to the MIN side fully (counterclockwise direction).
2. Connect a digital voltmeter to CN501 (TP) and CN601 (TP).
1P : \ominus side, 2P : \oplus side
3. Turn ON the power button, and adjust RV501 and RV601 so that the digital voltmeter display becomes $22\text{ mV} \pm 2\text{ mV}$ within 5 seconds.
4. After the adjustment, turn OFF the power button.

Adjustment Location
[MAIN BOARD] (Component side)

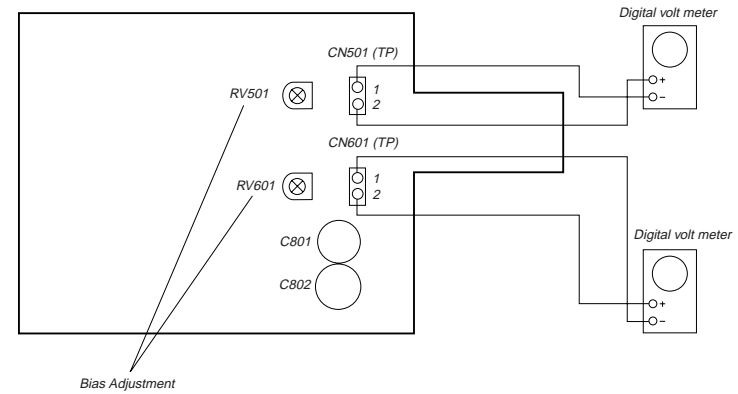

SECTION 3
DIAGRAMS

3-1. CIRCUIT BOARDS LOCATION

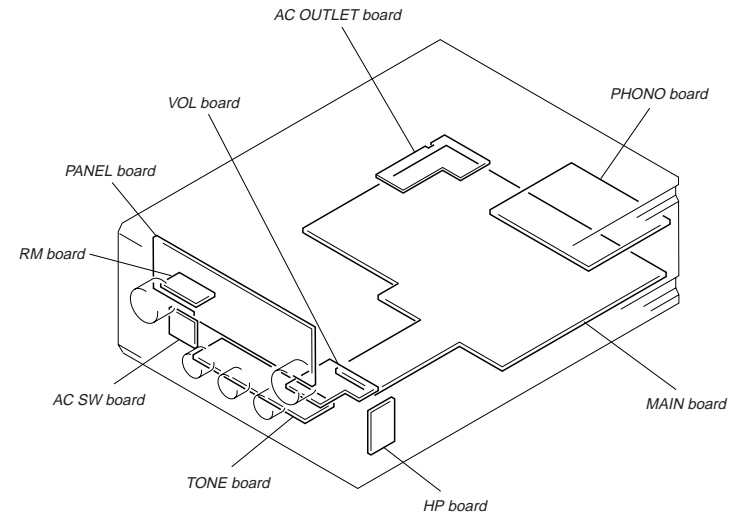

3-2. SCHEMATIC DIAGRAM — MAIN SECTION —
 • See page 13 for IC Block Diagrams.

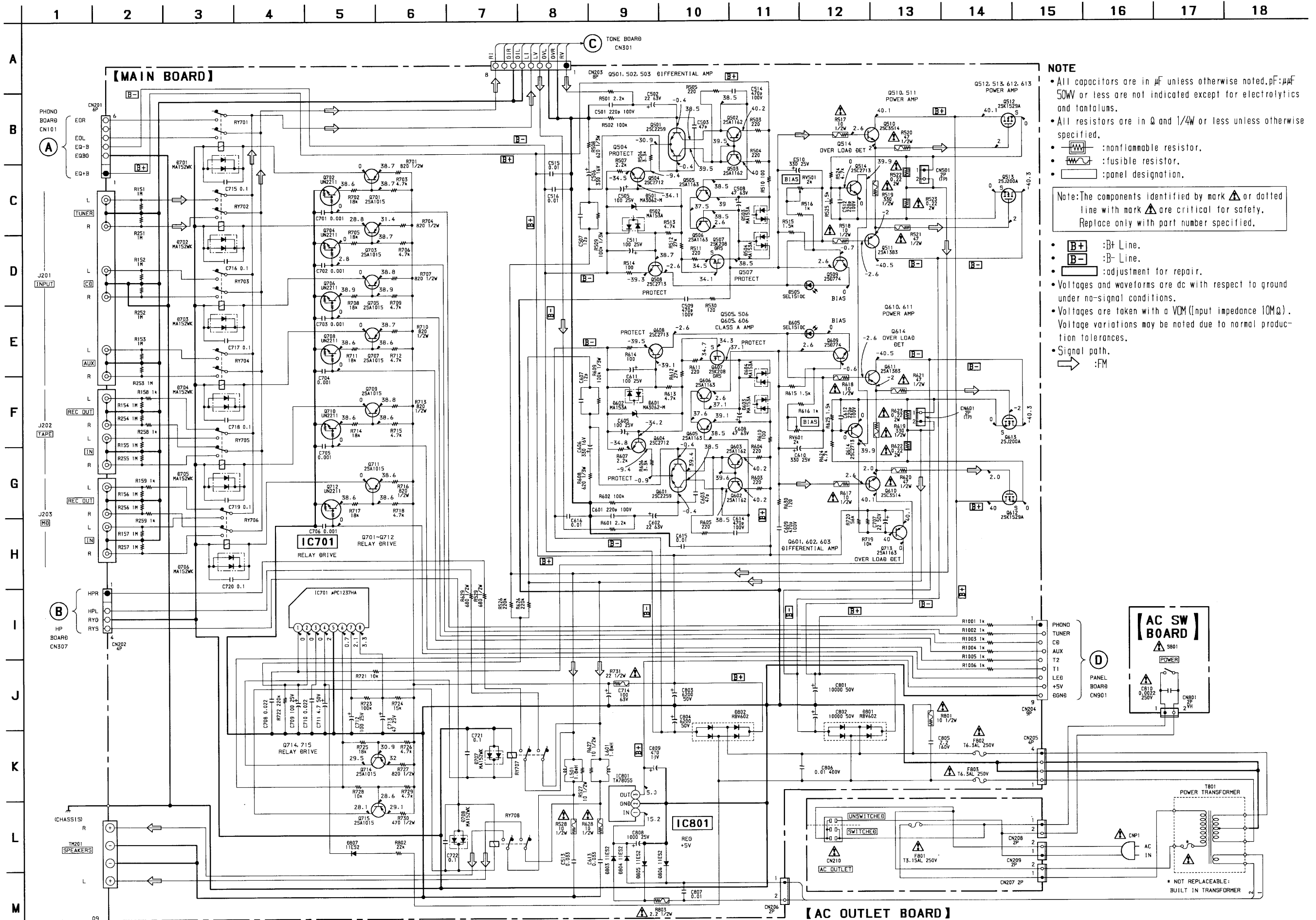

NOTE

- All capacitors are in μF unless otherwise noted, pF : μF 50WV or less are not indicated except for electrolytics and tantalums.
- All resistors are in Ω and $1/4W$ or less unless otherwise specified.
- \square : nonflammable resistor.
- \square : fusible resistor.
- \square : panel designation.

Note: The components identified by mark \triangle or dotted line with mark \triangle are critical for safety. Replace only with part number specified.

- $B+$: B+ Line.
- $B-$: B- Line.
- \square : adjustment for repair.
- Voltages and waveforms are dc with respect to ground under no-signal conditions.
- Voltages are taken with a VOM (Input impedance $10M\Omega$). Voltage variations may be noted due to normal production tolerances.
- Signal path.
- \rightarrow : FM

3-3. PRINTED WIRING BOARD —MAIN SECTION —
 • See page 4 for Circuit Boards Location.

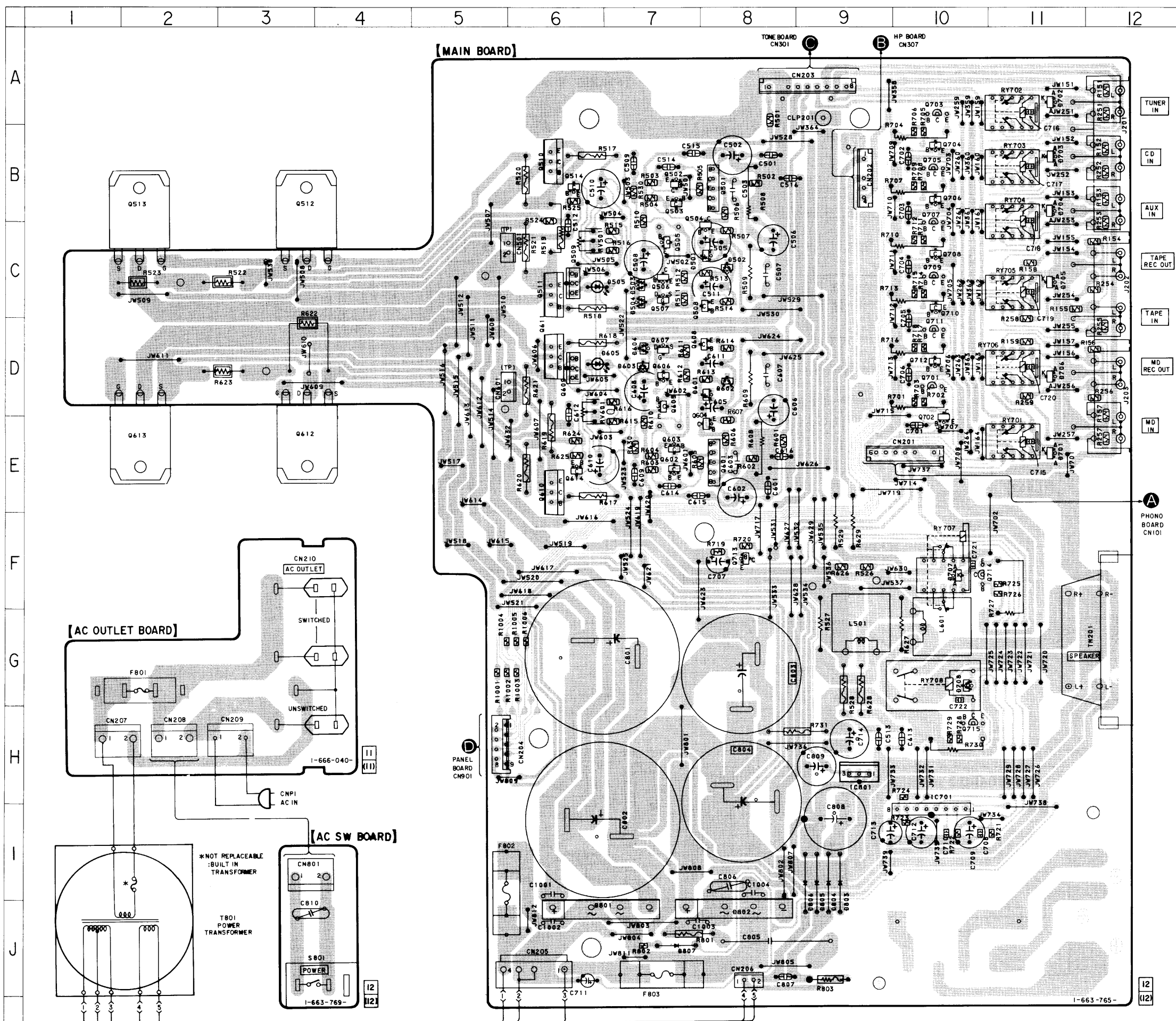

• Semiconductor Location

Ref. No.	Location
D501	C-7
D502	C-8
D503	C-7
D504	C-7
D505	C-7
D601	D-7
D602	D-8
D603	D-7
D604	D-7
D605	D-7
D701	E-11
D702	A-11
D703	B-11
D704	B-11
D705	C-11
D706	D-11
D707	F-10
D708	G-10
D801	J-6
D802	J-8
D803	I-9
D804	I-9
D805	I-9
D806	I-9
D807	J-7
IC701	H-10
IC801	H-9
Q501	B-8
Q502	B-7
Q503	B-7
Q504	B-7
Q505	C-7
Q506	C-7
Q507	C-7
Q508	C-7
Q509	C-6
Q510	B-6
Q511	C-6
Q512	B-3
Q513	B-2
Q514	B-6
Q601	E-8
Q602	E-7
Q603	E-7
Q604	D-8
Q605	D-7
Q606	D-7
Q607	D-7
Q608	D-7
Q609	D-6
Q610	E-6
Q611	C-6
Q612	E-3
Q613	E-2
Q614	E-6
Q701	D-10
Q702	D-10
Q703	A-10
Q704	B-10
Q705	B-10
Q706	B-10
Q707	B-10
Q708	C-10
Q709	C-10
Q710	C-10
Q711	C-10
Q712	D-10
Q713	F-8
Q714	F-10
Q715	H-10

Note:

- — : parts extracted from the component side.
- — : Pattern from the side which enable seeing.

3-4. SCHEMATIC DIAGRAM — PANEL SECTION —

- See page 13 for IC Block Diagrams.
- See page 14 for IC Pin Functions.

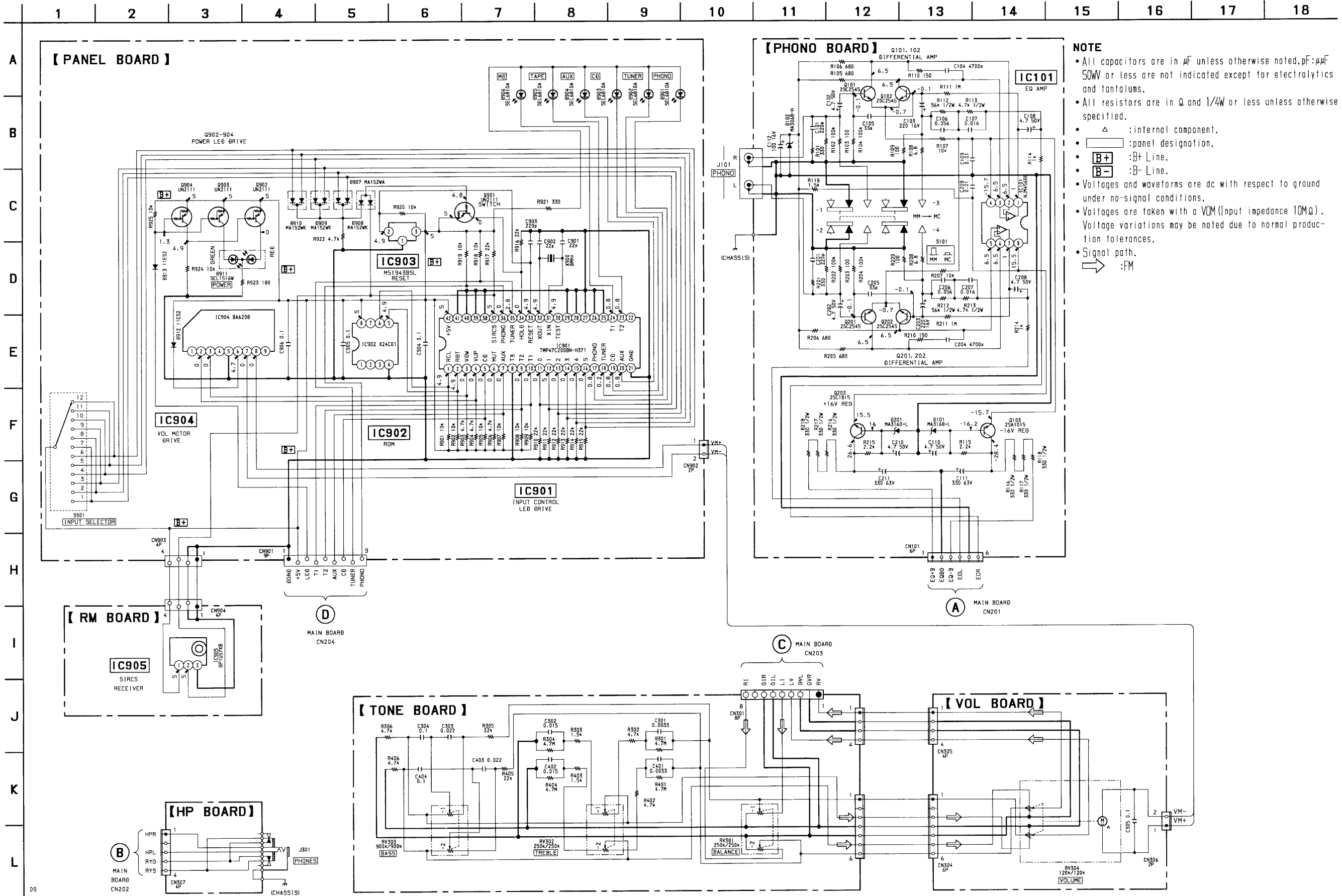

NOTE

- All capacitors are in μF unless otherwise noted. $\text{pF} = \mu\text{F} \times 10^{-6}$ or less are not indicated except for electrolytics and tantalums.
- All resistors are in Ω and $1/4\text{W}$ or less unless otherwise specified.
- Δ : internal component.
- \square : panel designation.
- $\text{B}+$: B+ Line.
- $\text{B}-$: B- Line.
- Voltages and waveforms are dc with respect to ground under no-signal conditions.
- Voltages are taken with a VOM (Input impedance $10\text{M}\Omega$). Voltage variations may be noted due to normal production tolerances.
- Signal path. \Rightarrow : FM

3-5. PRINTED WIRING BOARD — PANEL SECTION —

• See page 4 for Circuit Boards Location.

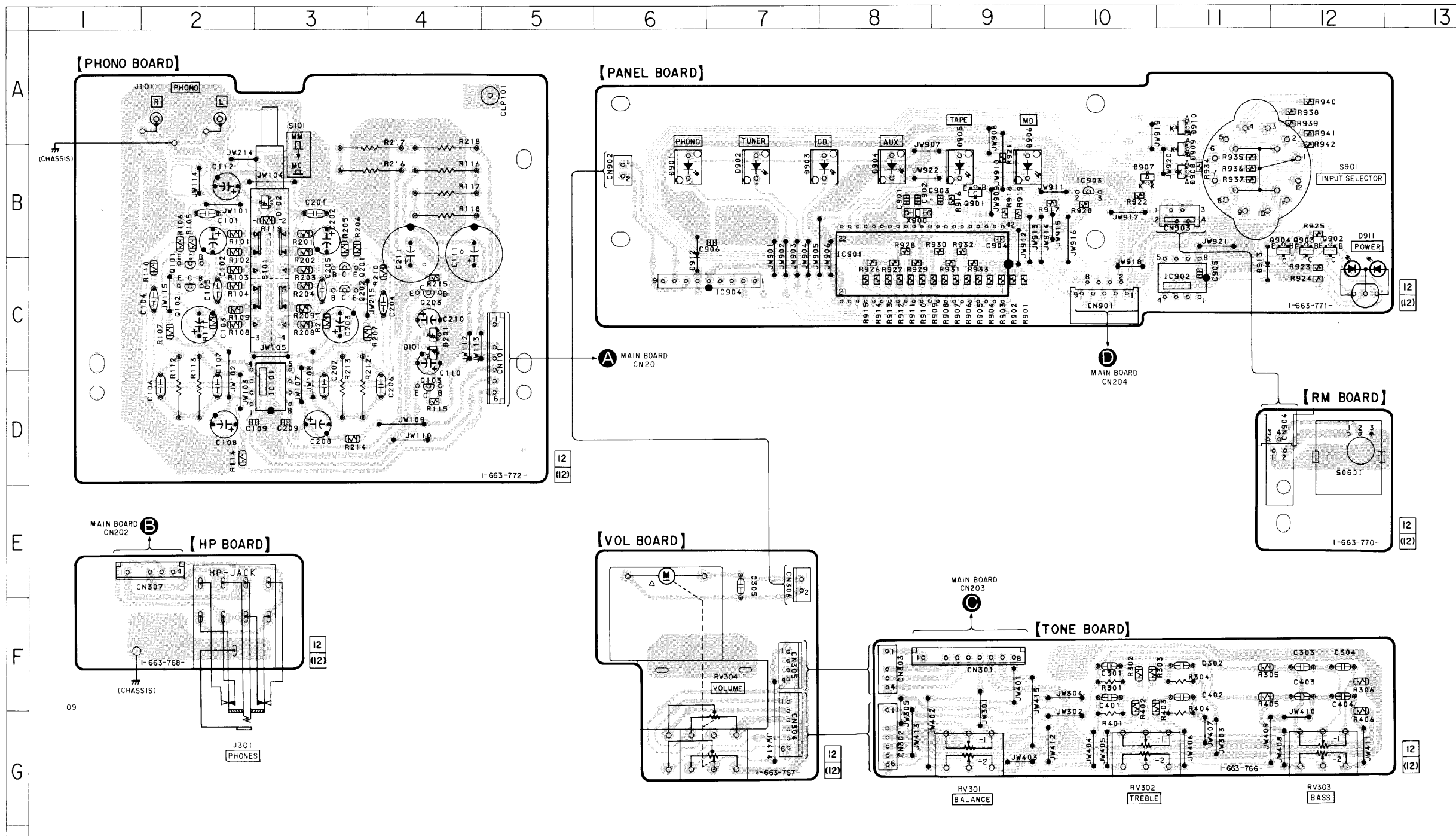

• Semiconductor Location

Ref. No.	Location
D101	C-4
D102	B-3
D201	C-4
D901	B-6
D902	B-7
D903	B-7
D904	B-8
D905	B-9
D906	B-9
D907	B-10
D908	B-11
D909	B-11
D910	A-11
D911	B-12
D912	C-6
D913	C-11
IC101	D-3
IC901	C-8
IC902	C-11
IC903	B-10
IC904	C-7
IC905	C-12
Q101	C-2
Q102	C-2
Q103	D-4
Q201	C-3
Q202	C-3
Q203	C-4
Q901	B-9
Q902	B-12
Q903	B-12
Q904	B-12

Note:

- ○ : parts extracted from the component side.
- △ : internal component.
- ▨ : Pattern from the side which enable seeing.

3-6. IC BLOCK DIAGRAMS

• Main section

IC701 μ PC1237HA

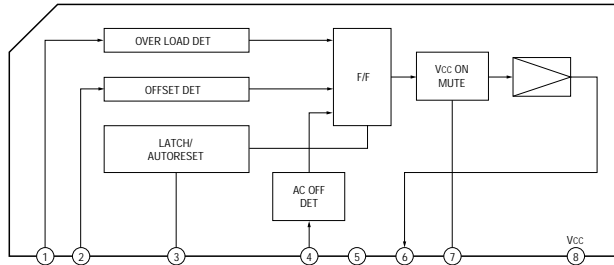

• Panel section

IC902 X24C01

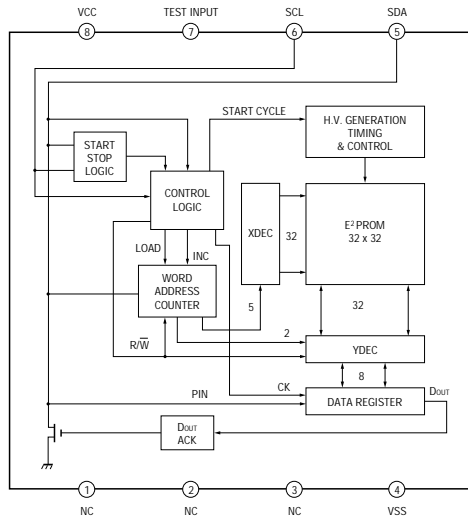

IC904 BA6208

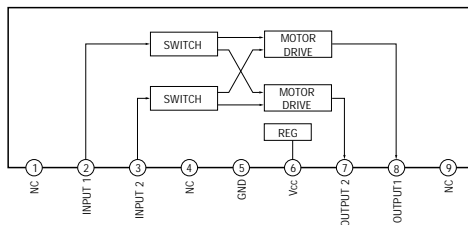

3-7. IC PIN FUNCTION

• IC901 TMP47C200BN-H371 (INPUT CONTROL, LED DRIVE)

Pin No.	Pin Name	I/O	Function
1	RCL	O	Clock
2	RDT	I/O	Data
3	VDW	O	Down
4	VUP	O	Up
5	CD	O	CD input relay signal output
6	MUT	O	Mute Control signal output when switching (Mute: H)
7	AUX	O	AUX input relay signal output
8	T3	I	Connected to ground
9	T2	O	TAPE input relay signal output
10	T1	O	MD input relay signal output
11	0	I	Relativity position detection signal of rotary switch (One of them terminal: L, the other terminal: H)
12	1	I	
13	2	I	
14	3	I	
15	4	I	
16	5	I	Function LED drive signal (ON: L)
17	PHONO	O	
18	TUNER	O	
19	CD	O	
20	AUX	O	Ground
21	GND	-	
22		-	Not used
23	T2	O	Function LED drive signal (ON: L)
24	T1	O	
25 to 29		-	Not used
30	TEST	I	Test terminal (Not used)
31	XIN	I	Oscillation signal 8MHz
32	XOUT	O	
33	RESET	I	Reset signal (Reset: L)
34	HOLD	I	Cancellation of hold mode signal (Start: H)
35	TUNER	O	TUNER input relay signal output
36	PHONO	O	PHONO input relay signal output
37	SIRCS	I	SIRCS signal (Active: L)
38 to 41		-	Not used
42	+5V	-	Power supply (+5V)

SECTION 4 EXPLODED VIEWS

NOTE:

- -XX, -X mean standardized parts, so they may have some difference from the original one.
- Items marked “*” are not stocked since they are seldom required for routine service. Some delay should be anticipated when ordering these items.
- The mechanical parts with no reference number in the exploded views are not supplied.
- Hardware (# mark) list and accessories and packing materials are given in the last of this parts list.

The components identified by mark \triangle or dotted line with mark \triangle are critical for safety.
Replace only with part number specified.

4-1. FRONT PANEL SECTION

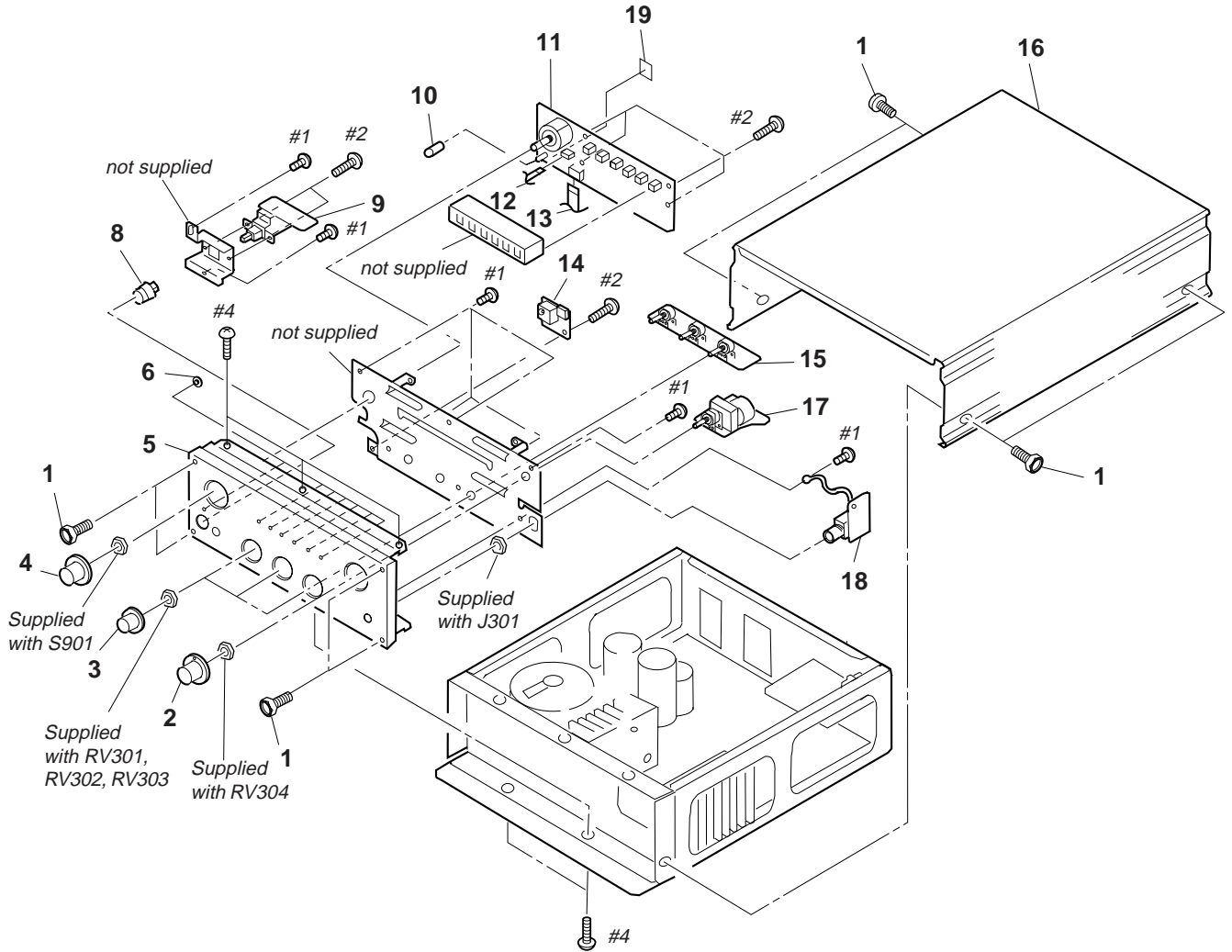

Ref. No.	Part No.	Description	Remark	Ref. No.	Part No.	Description	Remark
1	4-988-742-11	SCREW (M3X8), HEXAGON SOCKET		* 11	A-4392-951-A	PANEL BOARD, COMPLETE	
2	4-986-728-01	KNOB (VOL)		12	1-777-740-11	WIRE (FLAT TYPE) (4 CORE)	
3	4-986-729-01	KNOB (TONE)		13	1-777-739-11	WIRE (FLAT TYPE) (9 CORE)	
4	4-986-728-11	KNOB (VOL)		* 14	1-663-770-11	RM BOARD	
5	X-4947-788-1	PANEL SUB ASSY, FRONT (F3000)		* 15	1-663-766-11	TONE BOARD	
5	X-4948-711-1	PANEL SUB ASSY, FRONT (F3000ES)		* 16	4-986-716-01	CASE	
* 6	4-986-734-01	LENS, LED		* 17	1-663-767-11	VOL BOARD	
8	X-4947-759-1	BUTTON ASSY, POWER		* 18	1-663-768-11	HP BOARD	
* 9	1-663-769-11	AC SW BOARD		19	3-846-312-01	SPACER	
* 10	4-989-314-01	TUBE (LED)					

4-2. CHASSIS SECTION

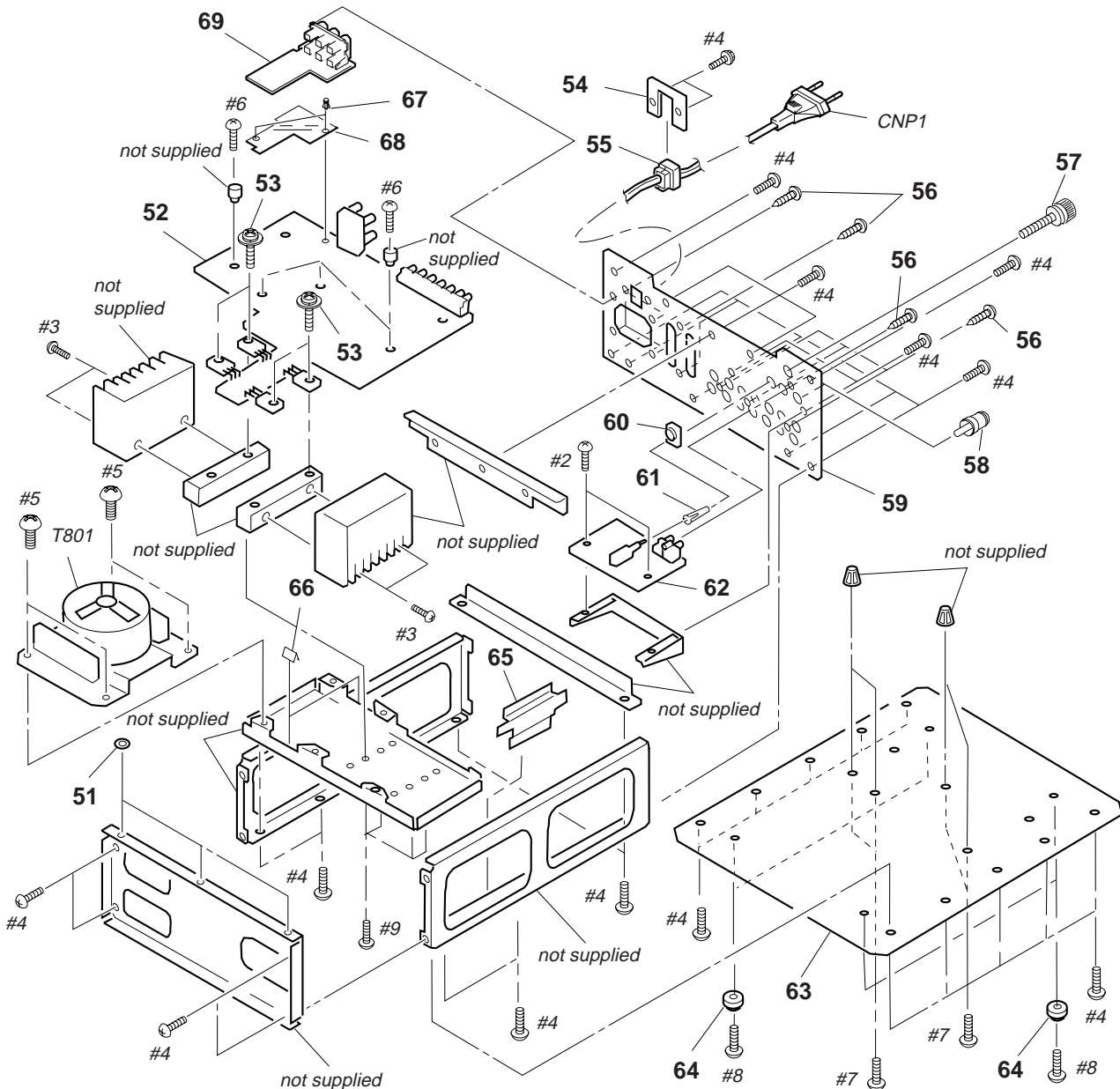

The components identified by mark Δ or dotted line with mark Δ are critical for safety.
Replace only with part number specified.

Ref. No.	Part No.	Description	Remark	Ref. No.	Part No.	Description	Remark
* 51	4-935-964-21	WASHER		61	4-970-146-01	BUTTON	
* 52	A-4392-944-A	MAIN BOARD, COMPLETE		* 62	A-4392-950-A	PHONO BOARD, COMPLETE	
53	X-4948-228-1	SCREW ASSY		* 63	4-986-722-01	PLATE, BOTTOM	
* 54	4-923-873-01	BRACKET, CORD STOPPER		64	X-4947-892-1	FOOT ASSY	
* 55	3-703-244-00	BUSHING (2104), CORD					
56	3-704-515-41	SCREW (BV/RING)		* 65	4-988-215-01	INSULATOR	
57	4-947-010-01	SCREW, FEEDER FIXED		66	3-831-441-XX	CUSHION, SPEAKER	
58	1-506-113-00	SHORT PLUG		67	3-531-576-11	RIVET	
* 59	4-990-696-01	PANEL, BACK (F3000)		68	4-992-453-01	INSULATOR	
* 59	4-990-696-11	PANEL, BACK (F3000ES)		* 69	1-666-040-11	AC OUTLET BOARD	
60	4-970-145-01	ESCUTCHEON (P)		Δ CNP1	1-558-568-21	CORD, POWER	
				Δ T801	1-431-369-11	TRANSFORMER, POWER	

SECTION 5 ELECTRICAL PARTS LIST

AC OUTLET

AC SW

HP

MAIN

Note:

The components identified by mark \triangle or dotted line with mark \triangle are critical for safety.
Replace only with part number specified.

When indicating parts by reference number, please include the board name.

- Due to standardization, replacements in the parts list may be different from the parts specified in the diagrams or the components used on the set.
- -XX, -X mean standardized parts, so they may have some difference from the original one.
- Items marked "*" are not stocked since they are seldom required for routine service. Some delay should be anticipated when ordering these items.
- RESISTORS
All resistors are in ohms
METAL: Metal-film resistor
METAL OXIDE: Metal Oxide-film resistor
F : nonflammable

- SEMICONDUCTORS
In each case, u: μ , for example:
uA...: μ A..., uPA...: μ PA..., uPB...: μ PB...,
uPC...: μ PC..., uPD...: μ PD...
- CAPACITORS
uF : μ F
- COILS
uH : μ H

Ref. No.	Part No.	Description	Remark	Ref. No.	Part No.	Description	Remark
*	1-666-040-11	AC OUTLET BOARD *****		*	A-4392-944-A	MAIN BOARD, COMPLETE *****	
		< CONNECTOR >				< CAPACITOR >	
* CN207	1-564-321-21	PIN, CONNECTOR 2P		C501	1-136-810-11	FILM 220PF	5% 100V
CN208	1-580-230-11	PIN, CONNECTOR (PC BOARD) 2P		C502	1-128-198-51	ELECT 22uF	20% 63V
CN209	1-564-321-00	PIN, CONNECTOR 2P		C503	1-101-880-00	CERAMIC 47PF	5% 50V
\triangle CN210	1-251-597-11	OUTLET, AC (AC OUTLET)		C505	1-115-197-11	ELECT 100uF	20% 25V
		< FUSE >		C506	1-126-025-11	ELECT 330uF	20% 16V
\triangle F801	1-532-465-51	FUSE, TIME-LAG (3.15A/250V)		C507	1-102-949-00	CERAMIC 12PF	5% 50V
		< FUSE HOLDER >		C508	1-128-200-11	ELECT 47uF	20% 63V
FH805	1-533-183-11	HOLDER, FUSE		C509	1-136-356-11	FILM 470PF	5% 100V
FH806	1-533-183-11	HOLDER, FUSE		C510	1-126-025-11	ELECT 330uF	20% 25V
		< TRANSFORMER >		C511	1-115-197-11	ELECT 100uF	20% 25V
\triangle T801	1-431-369-11	TRANSFORMER, POWER		C512	1-136-810-11	FILM 220PF	5% 100V
*****				C513	1-136-159-00	FILM 0.033uF	5% 50V
*	1-663-769-11	AC SW BOARD *****		C514	1-136-356-11	FILM 470PF	5% 100V
		< CAPACITOR >		C515	1-136-153-00	FILM 0.01uF	5% 50V
\triangle C810	1-113-920-11	CERAMIC 0.0022uF 20% 250V		C516	1-136-153-00	FILM 0.01uF	5% 50V
		< CONNECTOR >		C601	1-136-810-11	FILM 220PF	5% 100V
CN801	1-564-321-00	PIN, CONNECTOR 2P		C602	1-128-198-51	ELECT 22uF	20% 63V
		< SWITCH >		C603	1-101-880-00	CERAMIC 47PF	5% 50V
\triangle S801	1-762-581-11	SWITCH, AC POWER PUSH (1 KEY)(POWER)		C605	1-115-197-11	ELECT 100uF	20% 25V
*****				C606	1-126-025-11	ELECT 330uF	20% 16V
*	1-663-768-11	HP BOARD *****		C607	1-102-949-00	CERAMIC 12PF	5% 50V
		< CONNECTOR >		C608	1-128-200-11	ELECT 47uF	20% 63V
CN307	1-691-766-11	PLUG (MICRO CONNECTOR) 4P		C609	1-136-356-11	FILM 470PF	5% 100V
		< JACK >		C610	1-126-025-11	ELECT 330uF	20% 25V
J301	1-778-870-11	JACK (PHONES)		C611	1-115-197-11	ELECT 100uF	20% 25V
*****				C612	1-136-810-11	FILM 220PF	5% 100V
				C613	1-136-159-00	FILM 0.033uF	5% 50V
				C614	1-136-356-11	FILM 470PF	5% 100V
				C615	1-136-153-00	FILM 0.01uF	5% 50V
				C616	1-136-153-00	FILM 0.01uF	5% 50V
				C701	1-106-343-00	MYLAR 1000PF	5% 200V
				C702	1-106-343-00	MYLAR 1000PF	5% 200V
				C703	1-106-343-00	MYLAR 1000PF	5% 200V
				C704	1-106-343-00	MYLAR 1000PF	5% 200V
				C705	1-106-343-00	MYLAR 1000PF	5% 200V
				C706	1-106-343-00	MYLAR 1000PF	5% 200V
				C707	1-124-916-11	ELECT 22uF	20% 63V
				C708	1-163-037-11	CERAMIC CHIP 0.022uF	10% 25V
				C709	1-126-052-11	ELECT 100uF	20% 25V
				C710	1-163-037-11	CERAMIC CHIP 0.022uF	10% 25V
				C711	1-124-927-11	ELECT 4.7uF	20% 100V
				C712	1-126-052-11	ELECT 100uF	20% 25V

MAIN

Ref. No.	Part No.	Description	Remark	Ref. No.	Part No.	Description	Remark
C713	1-124-910-11	ELECT	47uF 20% 50V	D806	8-719-200-82	DIODE 11ES2	
C714	1-126-365-51	ELECT	100uF 20% 63V	D807	8-719-200-82	DIODE 11ES2	
C715	1-115-339-11	CERAMIC CHIP	0.1uF 10% 50V			< FUSE >	
C716	1-115-339-11	CERAMIC CHIP	0.1uF 10% 50V				
C717	1-115-339-11	CERAMIC CHIP	0.1uF 10% 50V	△ F802	1-532-506-51	FUSE, TIME-LAG (6.3A/250V)	
C718	1-115-339-11	CERAMIC CHIP	0.1uF 10% 50V	△ F803	1-532-506-51	FUSE, TIME-LAG (6.3A/250V)	
C719	1-115-339-11	CERAMIC CHIP	0.1uF 10% 50V			< FUSE HOLDER >	
C720	1-115-339-11	CERAMIC CHIP	0.1uF 10% 50V				
C721	1-115-339-11	CERAMIC CHIP	0.1uF 10% 50V	FH801	1-533-293-11	FUSE HOLDER	
C722	1-115-339-11	CERAMIC CHIP	0.1uF 10% 50V	FH802	1-533-293-11	FUSE HOLDER	
C801	1-117-394-12	ELECT	10000uF 20% 50V	FH803	1-533-293-11	FUSE HOLDER	
C802	1-117-394-12	ELECT	10000uF 20% 50V	FH804	1-533-293-11	FUSE HOLDER	
C803	1-117-395-11	ELECT	6200uF 20% 50V			< IC >	
C804	1-117-395-11	ELECT	6200uF 20% 50V	IC701	8-759-111-68	IC uPC1237HA	
C805	1-136-880-11	FILM	2.2uF 10% 160V	IC801	8-759-231-53	IC TA7805S	
C806	1-161-744-00	CERAMIC	0.01uF 400V			< JACK >	
C807	1-136-153-00	FILM	0.01uF 5% 50V				
C808	1-126-690-51	ELECT	1000uF 20% 25V	J201	1-566-883-41	JACK, PIN 6P (TUNER, CD, AUX IN)	
C809	1-126-103-11	ELECT	470uF 20% 16V	J202	1-566-882-41	JACK, PIN 4P (TAPE REC OUT, IN)	
C1001	1-102-824-00	CERAMIC	470PF 5% 50V	J203	1-566-882-41	JACK, PIN 4P (MD REC OUT, IN)	
C1002	1-102-824-00	CERAMIC	470PF 5% 50V			< COIL >	
C1003	1-102-824-00	CERAMIC	470PF 5% 50V				
C1004	1-102-824-00	CERAMIC	470PF 5% 50V	L501	1-411-766-11	COIL, AIR-CORE	
		< CONNECTOR >		L601	1-411-766-11	COIL, AIR-CORE	
CN201	1-691-768-11	PLUG (MICRO CONNECTOR) 6P				< TRANSISTOR >	
CN202	1-691-766-11	PLUG (MICRO CONNECTOR) 4P		Q501	8-729-620-17	TRANSISTOR 2SC2259-FG	
CN203	1-691-770-11	PLUG (MICRO CONNECTOR) 8P		Q502	8-729-216-22	TRANSISTOR 2SA1162-G	
* CN204	1-568-828-11	SOCKET, CONNECTOR 9P		Q503	8-729-216-22	TRANSISTOR 2SA1162-G	
CN205	1-766-897-11	PIN, CONNECTOR (PC BOARD) 4P		Q504	8-729-230-49	TRANSISTOR 2SC2712-YG	
CN206	1-564-505-11	PLUG, CONNECTOR 2P		Q505	8-729-216-31	TRANSISTOR 2SA1163-G	
CN501	1-564-505-11	PLUG, CONNECTOR 2P		Q506	8-729-216-31	TRANSISTOR 2SA1163-G	
CN601	1-564-505-11	PLUG, CONNECTOR 2P		Q507	8-729-232-69	TRANSISTOR 2SK208GR3	
		< DIODE >		Q508	8-729-271-31	TRANSISTOR 2SC2713-G	
D501	8-719-401-63	DIODE MA3062M-TX		Q509	8-729-140-96	TRANSISTOR 2SD774-34	
D502	8-719-800-76	DIODE 1SS226		Q510	8-729-104-18	TRANSISTOR 2SC3514-Q	
D503	8-719-800-76	DIODE 1SS226		Q511	8-729-104-91	TRANSISTOR 2SA1383	
D504	8-719-800-76	DIODE 1SS226		Q512	8-729-018-15	TRANSISTOR 2SK1529A-Y	
D505	8-719-310-60	DIODE SEL1510C-C		Q513	8-729-018-17	TRANSISTOR 2SJ200A-Y	
D601	8-719-401-63	DIODE MA3062M-TX		Q514	8-729-271-31	TRANSISTOR 2SC2713-G	
D602	8-719-800-76	DIODE 1SS226		Q601	8-729-620-17	TRANSISTOR 2SC2259-FG	
D603	8-719-800-76	DIODE 1SS226		Q602	8-729-216-22	TRANSISTOR 2SA1162-G	
D604	8-719-800-76	DIODE 1SS226		Q603	8-729-216-22	TRANSISTOR 2SA1162-G	
D605	8-719-310-60	DIODE SEL1510C-C		Q604	8-729-230-49	TRANSISTOR 2SC2712-YG	
D701	8-719-801-78	DIODE 1SS184		Q605	8-729-216-31	TRANSISTOR 2SA1163-G	
D702	8-719-801-78	DIODE 1SS184		Q606	8-729-216-31	TRANSISTOR 2SA1163-G	
D703	8-719-801-78	DIODE 1SS184		Q607	8-729-232-69	TRANSISTOR 2SK208GR3	
D704	8-719-801-78	DIODE 1SS184		Q608	8-729-271-31	TRANSISTOR 2SC2713-G	
D705	8-719-801-78	DIODE 1SS184		Q609	8-729-140-96	TRANSISTOR 2SD774-34	
D706	8-719-801-78	DIODE 1SS184		Q610	8-729-104-18	TRANSISTOR 2SC3514-Q	
D707	8-719-801-78	DIODE 1SS184		Q611	8-729-104-91	TRANSISTOR 2SA1383	
D708	8-719-801-78	DIODE 1SS184		Q612	8-729-018-15	TRANSISTOR 2SK1529A-Y	
D801	8-719-302-38	DIODE RBV-602-01		Q613	8-729-018-17	TRANSISTOR 2SJ200A-Y	
D802	8-719-302-38	DIODE RBV-602-01		Q614	8-729-271-31	TRANSISTOR 2SC2713-G	
D803	8-719-200-82	DIODE 11ES2		Q701	8-729-201-53	TRANSISTOR 2SA1015-GR	
D804	8-719-200-82	DIODE 11ES2		Q702	8-729-421-22	TRANSISTOR UN2211	
D805	8-719-200-82	DIODE 11ES2					

The components identified by mark △ or dotted line with mark △ are critical for safety.
Replace only with part number specified.

Ref. No.	Part No.	Description	Remark	Ref. No.	Part No.	Description	Remark
Q703	8-729-201-53	TRANSISTOR 2SA1015-GR		R526	1-216-254-00	CARBON MELF 220K	2%
Q704	8-729-421-22	TRANSISTOR UN2211		R527	1-247-727-11	CARBON 10	5%
Q705	8-729-201-53	TRANSISTOR 2SA1015-GR		△R528	1-212-958-00	FUSIBLE 10	5%
Q706	8-729-421-22	TRANSISTOR UN2211		R529	1-249-798-11	CARBON 680	5%
Q707	8-729-201-53	TRANSISTOR 2SA1015-GR		R530	1-259-984-11	CARBON MELF 120	2%
Q708	8-729-421-22	TRANSISTOR UN2211		R601	1-259-999-11	CARBON MELF 2.2K	2%
Q709	8-729-201-53	TRANSISTOR 2SA1015-GR		R602	1-260-020-11	CARBON MELF 100K	2%
Q710	8-729-421-22	TRANSISTOR UN2211		R603	1-259-987-11	CARBON MELF 220	2%
Q711	8-729-201-53	TRANSISTOR 2SA1015-GR		R604	1-259-987-11	CARBON MELF 220	2%
Q712	8-729-421-22	TRANSISTOR UN2211		R605	1-259-987-11	CARBON MELF 220	2%
Q713	8-729-216-31	TRANSISTOR 2SA1163-G		R606	1-260-002-11	CARBON MELF 3.3K	2%
Q714	8-729-201-53	TRANSISTOR 2SA1015-GR		R607	1-259-999-11	CARBON MELF 2.2K	2%
Q715	8-729-201-53	TRANSISTOR 2SA1015-GR		R608	1-247-235-00	CARBON 620	5%
		< RESISTOR >		R609	1-249-496-11	CARBON 100K	5%
R151	1-260-032-11	CARBON MELF 1M	2%	R610	1-259-983-11	CARBON MELF 100	2%
R152	1-260-032-11	CARBON MELF 1M	2%	R611	1-259-987-11	CARBON MELF 220	2%
R153	1-260-032-11	CARBON MELF 1M	2%	R612	1-260-013-11	CARBON MELF 27K	2%
R154	1-260-032-11	CARBON MELF 1M	2%	R613	1-260-004-11	CARBON MELF 4.7K	2%
R155	1-260-032-11	CARBON MELF 1M	2%	R614	1-259-983-11	CARBON MELF 100	2%
R156	1-260-032-11	CARBON MELF 1M	2%	R615	1-259-997-11	CARBON MELF 1.5K	2%
R157	1-260-032-11	CARBON MELF 1M	2%	R616	1-259-995-11	CARBON MELF 1K	2%
R158	1-259-995-11	CARBON MELF 1K	2%	△R617	1-212-958-00	FUSIBLE 10	5%
R159	1-259-995-11	CARBON MELF 1K	2%	△R618	1-212-958-00	FUSIBLE 10	5%
R251	1-260-032-11	CARBON MELF 1M	2%	△R619	1-212-994-00	FUSIBLE 330	5%
R252	1-260-032-11	CARBON MELF 1M	2%	△R620	1-212-974-00	FUSIBLE 47	5%
R253	1-260-032-11	CARBON MELF 1M	2%	△R621	1-212-974-00	FUSIBLE 47	5%
R254	1-260-032-11	CARBON MELF 1M	2%	△R622	1-208-602-11	WIREWOUND 0.22	10%
R255	1-260-032-11	CARBON MELF 1M	2%	△R623	1-208-602-11	WIREWOUND 0.22	10%
R256	1-260-032-11	CARBON MELF 1M	2%	R624	1-260-004-11	CARBON MELF 4.7K	2%
R257	1-260-032-11	CARBON MELF 1M	2%	R625	1-259-997-11	CARBON MELF 1.5K	2%
R258	1-259-995-11	CARBON MELF 1K	2%	R626	1-216-254-00	CARBON MELF 220K	2%
R259	1-259-995-11	CARBON MELF 1K	2%	R627	1-247-727-11	CARBON 10	5%
R501	1-259-999-11	CARBON MELF 2.2K	2%	△R628	1-212-958-00	FUSIBLE 10	5%
R502	1-260-020-11	CARBON MELF 100K	2%	R629	1-249-798-11	CARBON 680	5%
R503	1-259-987-11	CARBON MELF 220	2%	R630	1-259-984-11	CARBON MELF 120	2%
R504	1-259-987-11	CARBON MELF 220	2%	R701	1-247-751-11	CARBON 820	5%
R505	1-259-987-11	CARBON MELF 220	2%	R702	1-208-812-11	METAL GLAZE 18K	2%
R506	1-260-002-11	CARBON MELF 3.3K	2%	R703	1-208-453-41	METAL GLAZE 4.7K	2%
R507	1-259-999-11	CARBON MELF 2.2K	2%	R704	1-247-751-11	CARBON 820	5%
R508	1-247-235-00	CARBON 620	5%	R705	1-208-812-11	METAL GLAZE 18K	2%
R509	1-249-496-11	CARBON 100K	5%	R706	1-208-453-41	METAL GLAZE 4.7K	2%
R510	1-259-983-11	CARBON MELF 100	2%	R707	1-247-751-11	CARBON 820	5%
R511	1-259-987-11	CARBON MELF 220	2%	R708	1-208-812-11	METAL GLAZE 18K	2%
R512	1-260-013-11	CARBON MELF 27K	2%	R709	1-208-453-41	METAL GLAZE 4.7K	2%
R513	1-260-004-11	CARBON MELF 4.7K	2%	R710	1-247-751-11	CARBON 820	5%
R514	1-259-983-11	CARBON MELF 100	2%	R711	1-208-812-11	METAL GLAZE 18K	2%
R515	1-259-997-11	CARBON MELF 1.5K	2%	R712	1-208-453-41	METAL GLAZE 4.7K	2%
R516	1-259-995-11	CARBON MELF 1K	2%	R713	1-247-751-11	CARBON 820	5%
△R517	1-212-958-00	FUSIBLE 10	5%	R714	1-208-812-11	METAL GLAZE 18K	2%
△R518	1-212-958-00	FUSIBLE 10	5%	R715	1-208-453-41	METAL GLAZE 4.7K	2%
△R519	1-212-994-00	FUSIBLE 330	5%	R716	1-247-751-11	CARBON 820	5%
△R520	1-212-974-00	FUSIBLE 47	5%	R717	1-208-812-11	METAL GLAZE 18K	2%
△R521	1-212-974-00	FUSIBLE 47	5%	R718	1-208-453-41	METAL GLAZE 4.7K	2%
△R522	1-208-602-11	WIREWOUND 0.22	10%	R719	1-260-008-11	CARBON MELF 10K	2%
△R523	1-208-602-11	WIREWOUND 0.22	10%	R720	1-260-017-11	CARBON MELF 56K	2%
R524	1-260-004-11	CARBON MELF 4.7K	2%	R721	1-208-462-41	METAL GLAZE 10K	2%
R525	1-259-997-11	CARBON MELF 1.5K	2%	R722	1-218-760-11	METAL GLAZE 220K	2%

The components identified by mark △ or dotted line with mark △ are critical for safety.
Replace only with part number specified.

MAIN

PANEL

Ref. No.	Part No.	Description			Remark
R723	1-216-699-11	METAL CHIP	100K	0.5%	1/10W
R724	1-208-810-11	METAL GLAZE	15K	2%	1/10W
R725	1-208-812-11	METAL GLAZE	18K	2%	1/10W
R726	1-208-453-41	METAL GLAZE	4.7K	2%	1/10W
R727	1-247-751-11	CARBON	820	5%	1/2W
R728	1-208-462-41	METAL GLAZE	10K	2%	1/10W
R729	1-208-453-41	METAL GLAZE	4.7K	2%	1/10W
R730	1-249-665-11	CARBON	470	5%	1/2W
△R731	1-212-966-00	FUSIBLE	22	5%	1/2W F
△R801	1-212-958-00	FUSIBLE	10	5%	1/2W F
R802	1-208-518-41	METAL GLAZE	22K	2%	1/10W
△R803	1-212-942-00	FUSIBLE	2.2	5%	1/2W F
R1001	1-208-437-41	METAL GLAZE	1K	2%	1/10W
R1002	1-208-437-41	METAL GLAZE	1K	2%	1/10W
R1003	1-208-437-41	METAL GLAZE	1K	2%	1/10W
R1004	1-208-437-41	METAL GLAZE	1K	2%	1/10W
R1005	1-208-437-41	METAL GLAZE	1K	2%	1/10W
R1006	1-208-437-41	METAL GLAZE	1K	2%	1/10W
< VARIABLE RESISTOR >					
RV501	1-237-457-21	RES, ADJ, CARBON 2K			
RV601	1-237-457-21	RES, ADJ, CARBON 2K			
< RELAY >					
RY701	1-755-062-11	RELAY			
RY702	1-755-062-11	RELAY			
RY703	1-755-062-11	RELAY			
RY704	1-755-062-11	RELAY			
RY705	1-755-062-11	RELAY			
RY706	1-755-062-11	RELAY			
RY707	1-755-062-11	RELAY			
RY708	1-515-920-11	RELAY (24V)			
< TERMINAL >					
TM201	1-537-530-21	TERMINAL BOARD (SPEAKER)			

*	A-4392-951-A	PANEL BOARD, COMPLETE			

< CAPACITOR >					
C901	1-163-235-11	CERAMIC CHIP	22PF	5%	50V
C902	1-163-235-11	CERAMIC CHIP	22PF	5%	50V
C903	1-163-001-11	CERAMIC CHIP	220PF	10%	50V
C904	1-107-725-11	CERAMIC CHIP	0.1uF	10%	16V
C905	1-107-725-11	CERAMIC CHIP	0.1uF	10%	16V
C906	1-107-725-11	CERAMIC CHIP	0.1uF	10%	16V
< CONNECTOR >					
* CN901	1-568-852-11	SOCKET, CONNECTOR 9P			
* CN903	1-568-823-11	SOCKET, CONNECTOR 4P			
< DIODE >					
D901	8-719-313-50	DIODE SEL6810A-TH12 (PHONO)			
D902	8-719-313-50	DIODE SEL6810A-TH12 (TUNER)			
D903	8-719-313-50	DIODE SEL6810A-TH12 (CD)			
D904	8-719-313-50	DIODE SEL6810A-TH12 (AUX)			

Ref. No.	Part No.	Description			Remark
D905	8-719-313-50	DIODE SEL6810A-TH12 (TAPE)			
D906	8-719-313-50	DIODE SEL6810A-TH12 (MD)			
D907	8-719-400-20	DIODE MA152WA			
D908	8-719-801-78	DIODE 1SS184			
D909	8-719-801-78	DIODE 1SS184			
D910	8-719-801-78	DIODE 1SS184			
D911	8-719-313-40	DIODE SEL1516W (POWER)			
D912	8-719-200-82	DIODE 11ES2			
D913	8-719-200-82	DIODE 11ES2			
< IC >					
IC901	8-759-440-61	IC TMP47C200BN-H371(Z)			
IC902	8-759-188-67	IC X24C01P-S			
IC903	8-759-635-63	IC M51943BSL			
IC904	8-759-962-08	IC BA6208			
< TRANSISTOR >					
Q901	8-729-424-08	TRANSISTOR UN2111			
Q902	8-729-424-08	TRANSISTOR UN2111			
Q903	8-729-424-08	TRANSISTOR UN2111			
Q904	8-729-424-08	TRANSISTOR UN2111			
< RESISTOR >					
R901	1-208-462-41	METAL GLAZE	10K	2%	1/10W
R902	1-208-462-41	METAL GLAZE	10K	2%	1/10W
R903	1-208-453-41	METAL GLAZE	4.7K	2%	1/10W
R904	1-208-453-41	METAL GLAZE	4.7K	2%	1/10W
R905	1-208-462-41	METAL GLAZE	10K	2%	1/10W
R906	1-208-453-41	METAL GLAZE	4.7K	2%	1/10W
R907	1-208-462-41	METAL GLAZE	10K	2%	1/10W
R908	1-208-462-41	METAL GLAZE	10K	2%	1/10W
R909	1-208-462-41	METAL GLAZE	10K	2%	1/10W
R910	1-208-518-41	METAL GLAZE	22K	2%	1/10W
R911	1-208-518-41	METAL GLAZE	22K	2%	1/10W
R912	1-208-518-41	METAL GLAZE	22K	2%	1/10W
R913	1-208-518-41	METAL GLAZE	22K	2%	1/10W
R914	1-208-518-41	METAL GLAZE	22K	2%	1/10W
R915	1-208-518-41	METAL GLAZE	22K	2%	1/10W
R916	1-208-518-41	METAL GLAZE	22K	2%	1/10W
R917	1-208-518-41	METAL GLAZE	22K	2%	1/10W
R918	1-208-462-41	METAL GLAZE	10K	2%	1/10W
R919	1-208-462-41	METAL GLAZE	10K	2%	1/10W
R920	1-208-462-41	METAL GLAZE	10K	2%	1/10W
R921	1-208-425-41	METAL GLAZE	330	2%	1/10W
R922	1-208-453-41	METAL GLAZE	4.7K	2%	1/10W
R923	1-208-764-11	METAL GLAZE	180	2%	1/10W
R924	1-208-462-41	METAL GLAZE	10K	2%	1/10W
R925	1-208-462-41	METAL GLAZE	10K	2%	1/10W
R926	1-216-295-91	CONDUCTOR, CHIP (2012)			
R927	1-216-295-91	CONDUCTOR, CHIP (2012)			
R928	1-216-295-91	CONDUCTOR, CHIP (2012)			
R929	1-216-295-91	CONDUCTOR, CHIP (2012)			
R930	1-216-295-91	CONDUCTOR, CHIP (2012)			
R931	1-216-295-91	CONDUCTOR, CHIP (2012)			
R932	1-216-295-91	CONDUCTOR, CHIP (2012)			
R933	1-216-295-91	CONDUCTOR, CHIP (2012)			
R934	1-216-295-91	CONDUCTOR, CHIP (2012)			
R935	1-216-295-91	CONDUCTOR, CHIP (2012)			

The components identified by mark △ or dotted line with mark △ are critical for safety.
Replace only with part number specified.

PANEL

PHONO

RM

Ref. No.	Part No.	Description	Remark	Ref. No.	Part No.	Description	Remark
R936	1-216-295-91	CONDUCTOR, CHIP (2012)				< TRANSISTOR >	
R937	1-216-295-91	CONDUCTOR, CHIP (2012)					
R938	1-216-295-91	CONDUCTOR, CHIP (2012)					
R939	1-216-295-91	CONDUCTOR, CHIP (2012)		Q101	8-729-354-52	TRANSISTOR 2SC2545	
R940	1-216-295-91	CONDUCTOR, CHIP (2012)		Q102	8-729-354-52	TRANSISTOR 2SC2545	
				Q103	8-729-201-53	TRANSISTOR 2SA1015-GR	
R941	1-216-295-91	CONDUCTOR, CHIP (2012)		Q201	8-729-354-52	TRANSISTOR 2SC2545	
R942	1-216-295-91	CONDUCTOR, CHIP (2012)		Q202	8-729-354-52	TRANSISTOR 2SC2545	
		< SWITCH >					
S901	1-762-873-11	SWITCH, ROTARY (INPUT SELECTOR)		Q203	8-729-119-78	TRANSISTOR 2SC2785-HFE	
		< VIBRATOR >				< RESISTOR >	
X900	1-579-223-11	OSCILLATOR, CERAMIC (8MHz)		R101	1-259-989-11	CARBON MELF 330 2%	1/8W
				R102	1-260-020-11	CARBON MELF 100K 2%	1/8W
				R103	1-259-983-11	CARBON MELF 100 2%	1/8W
				R104	1-260-020-11	CARBON MELF 100K 2%	1/8W
				R105	1-249-415-11	CARBON 680 5%	1/4W F
*****				R106	1-249-415-11	CARBON 680 5%	1/4W F
*	A-4392-950-A	PHONO BOARD, COMPLETE		R107	1-260-008-11	CARBON MELF 10K 2%	1/8W
		*****		R108	1-216-146-00	CARBON MELF 6.8 2%	1/8W
		< CAPACITOR >		R109	1-259-983-11	CARBON MELF 100 2%	1/8W
				R110	1-259-985-11	CARBON MELF 150 2%	1/8W
C101	1-102-110-00	CERAMIC 220PF 10% 50V		R111	1-260-032-11	CARBON MELF 1M 2%	1/8W
C102	1-124-927-11	ELECT 4.7uF 20% 100V		R112	1-249-844-11	CARBON 56K 1%	1/2W
C103	1-126-024-11	ELECT 220uF 20% 16V		R113	1-249-818-11	CARBON 4.7K 1%	1/2W
C104	1-164-093-11	CERAMIC 0.0047uF 10% 25V		R114	1-259-995-11	CARBON MELF 1K 2%	1/8W
C105	1-164-058-11	CERAMIC 33PF 5% 50V		R115	1-208-445-41	METAL GLAZE 2.2K 2%	1/10W
C106	1-136-162-00	FILM 0.056uF 5% 50V		R116	1-249-661-11	CARBON 330 5%	1/2W
C107	1-137-471-11	FILM 0.016uF 5% 50V		R117	1-249-661-11	CARBON 330 5%	1/2W
C108	1-124-927-11	ELECT 4.7uF 20% 100V		R118	1-249-661-11	CARBON 330 5%	1/2W
C109	1-164-232-11	CERAMIC CHIP 0.01uF 50V		R119	1-259-997-11	CARBON MELF 1.5K 2%	1/8W
C110	1-124-927-11	ELECT 4.7uF 20% 100V		R201	1-259-989-11	CARBON MELF 330 2%	1/8W
C111	1-110-395-11	ELECT 330uF 20% 63V		R202	1-260-020-11	CARBON MELF 100K 2%	1/8W
C112	1-126-052-11	ELECT 100uF 20% 16V		R203	1-259-983-11	CARBON MELF 100 2%	1/8W
C201	1-102-110-00	CERAMIC 220PF 10% 50V		R204	1-260-020-11	CARBON MELF 100K 2%	1/8W
C202	1-124-927-11	ELECT 4.7uF 20% 100V		R205	1-249-415-11	CARBON 680 5%	1/4W F
C203	1-126-024-11	ELECT 220uF 20% 16V		R206	1-249-415-11	CARBON 680 5%	1/4W F
C204	1-164-093-11	CERAMIC 0.0047uF 10% 25V		R207	1-260-008-11	CARBON MELF 10K 2%	1/8W
C205	1-164-058-11	CERAMIC 33PF 5% 50V		R208	1-216-146-00	CARBON MELF 6.8 2%	1/8W
C206	1-136-162-00	FILM 0.056uF 5% 50V		R209	1-259-983-11	CARBON MELF 100 2%	1/8W
C207	1-137-471-11	FILM 0.016uF 5% 50V		R210	1-259-985-11	CARBON MELF 150 2%	1/8W
C208	1-124-927-11	ELECT 4.7uF 20% 100V		R211	1-260-032-11	CARBON MELF 1M 2%	1/8W
C209	1-164-232-11	CERAMIC CHIP 0.01uF 50V		R212	1-249-844-11	CARBON 56K 1%	1/2W
C210	1-124-927-11	ELECT 4.7uF 20% 100V		R213	1-249-818-11	CARBON 4.7K 1%	1/2W
C211	1-110-395-11	ELECT 330uF 20% 63V		R214	1-259-995-11	CARBON MELF 1K 2%	1/8W
		< CONNECTOR >		R215	1-208-445-41	METAL GLAZE 2.2K 2%	1/10W
CN101	1-691-768-11	PLUG (MICRO CONNECTOR) 6P		R216	1-249-661-11	CARBON 330 5%	1/2W
		< DIODE >		R217	1-249-661-11	CARBON 330 5%	1/2W
D101	8-719-401-06	DIODE MA3160L-TX		R218	1-249-661-11	CARBON 330 5%	1/2W
D102	8-719-400-64	DIODE MA3068H-TX				< SWITCH >	
D201	8-719-401-06	DIODE MA3160L-TX		S101	1-762-395-11	SWITCH, PUSH (1 KEY)(MM → MC)	
		< IC >		*****			
IC101	8-759-745-61	IC NJM4560D-D		*	1-663-770-11	RM BOARD	
		< JACK >				*****	
J101	1-568-250-21	JACK, PIN 2P (PHONO)				< CONNECTOR >	
				* CN904	1-568-847-11	SOCKET, CONNECTOR 4P	

TA-F3000/F3000ES

RM **TONE** **VOL**

Ref. No.	Part No.	Description	Remark
		< IC >	
IC905	8-749-923-43	IC GP1U57XB	

*	1-663-766-11	TONE BOARD *****	
		< CAPACITOR >	
C301	1-130-477-00	MYLAR 0.0033uF 5% 50V	
C302	1-136-155-00	FILM 0.015uF 5% 50V	
C303	1-136-157-00	FILM 0.022uF 5% 50V	
C304	1-136-165-00	FILM 0.1uF 5% 50V	
C401	1-130-477-00	MYLAR 0.0033uF 5% 50V	
C402	1-136-155-00	FILM 0.015uF 5% 50V	
C403	1-136-157-00	FILM 0.022uF 5% 50V	
C404	1-136-165-00	FILM 0.1uF 5% 50V	
		< CONNECTOR >	
CN301	1-691-770-11	PLUG (MICRO CONNECTOR) 8P	
		< RESISTOR >	
R301	1-259-884-11	CARBON 4.7M 5% 1/4W	
R302	1-260-004-11	CARBON MELF 4.7K 2% 1/8W	
R303	1-259-997-11	CARBON MELF 1.5K 2% 1/8W	
R304	1-259-884-11	CARBON 4.7M 5% 1/4W	
R305	1-260-012-11	CARBON MELF 22K 2% 1/8W	
R306	1-260-004-11	CARBON MELF 4.7K 2% 1/8W	
R401	1-259-884-11	CARBON 4.7M 5% 1/4W	
R402	1-260-004-11	CARBON MELF 4.7K 2% 1/8W	
R403	1-259-997-11	CARBON MELF 1.5K 2% 1/8W	
R404	1-259-884-11	CARBON 4.7M 5% 1/4W	
R405	1-260-012-11	CARBON MELF 22K 2% 1/8W	
R406	1-260-004-11	CARBON MELF 4.7K 2% 1/8W	
		< VARIABLE RESISTOR >	
RV301	1-225-368-11	RES, VAR, CARBON 250K/250K (BALANCE)	
RV302	1-225-369-11	RES, VAR, CARBON 250K/250K (TREBLE)	
RV303	1-225-370-11	RES, VAR, CARBON 900K/900K (BASS)	

*	1-663-767-11	VOL BOARD *****	
		< CAPACITOR >	
C305	1-136-165-00	FILM 0.1uF 5% 50V	
		< CONNECTOR >	
* CN304	1-564-708-11	PIN, CONNECTOR (SMALL TYPE) 6P	
* CN305	1-564-706-11	PIN, CONNECTOR (SMALL TYPE) 4P	
CN306	1-564-505-11	PLUG, CONNECTOR 2P	
		< VARIABLE RESISTOR >	
RV304	1-225-367-11	RES, VAR, CARBON 120K/120K (VOLUME)	

Ref. No.	Part No.	Description	Remark
		MISCELLANEOUS *****	
12	1-777-740-11	WIRE (FLAT TYPE) (4 CORE)	
13	1-777-739-11	WIRE (FLAT TYPE) (9 CORE)	
58	1-506-113-00	SHORT PLUG	
△ CNP1	1-558-568-21	CORD, POWER	
△ T801	1-431-369-11	TRANSFORMER, POWER	

		ACCESSORIES & PACKING MATERIALS *****	
	1-473-956-11	REMOTE COMMANDER (RM-S3000)	
	3-858-906-11	MANUAL, INSTRUCTION (ENGLISH, FINNISH, SPANISH, PORTUGUESE, CHINESE)	
	3-858-906-21	MANUAL, INSTRUCTION (GERMAN, DUTCH, ITALIAN, SWEDISH) (AEP,UK)	
	4-987-064-01	COVER, BATTERY (For RM-S3000)	

		***** HARDWARE LIST *****	
#1	7-621-259-25	SCREW +P 2.6X4	
#2	7-685-871-01	SCREW +BVTT 3X6 (S)	
#3	7-682-548-04	SCREW +P 3X8	
#4	7-685-872-09	SCREW +BVTT 3X8 (S)	
#5	7-685-880-09	SCREW +BVTT 4X6 (S)	
#6	7-685-648-79	SCREW +BVTP 3X12 TYPE2 N-S	
#7	7-685-646-79	SCREW +BVTP 3X8 TYPE2 N-S	
#8	7-685-874-09	SCREW +BVTT 3X12 (S)	
#9	7-682-548-09	SCREW (3X8)	

The components identified by mark △ or dotted line with mark △ are critical for safety.
Replace only with part number specified.