

TA-F317R/F417R

SERVICE MANUAL

AEP Model

TA-F317R/F417R

E Model

TA-F417R



PHOTO : TA-F417R

SPECIFICATIONS

Amplifier

Continuous RMS power output (both channels driven simultaneously)

Model for Germany

		TA-F417R	
DIN, 1 kHz	4 ohms	80 W + 80 W	
	6 ohms	—	
	8 ohms	60 W + 60 W	
20 Hz – 20 kHz THD 0.05%	4 ohms	70 W + 70 W	
	8 ohms	—	

Model for Scandinavian countries, Spain and Portugal

		TA-F317R	TA-F417R
DIN, 1kHz	4 ohms	—	—
	6 ohms	—	80 W + 80 W
	8 ohms	50 W + 50 W	70 W + 70 W
20 Hz -20 kHz THD 0.05 %	4 ohms	—	—
	8 ohms	40 W + 40 W	60 W + 60 W

Model for other European countries

		TA-F317R	TA-F417R
DIN, 1 kHz	4 ohms	—	80 W + 80 W
	6 ohms	—	—
	8 ohms	50 W + 50 W	75 W + 75 W
20 Hz – 20 kHz THD 0.05 %	4 ohms	—	—
	8 ohms	40 W + 40 W	65 W + 65 W

Model for other countries

		TA-F417R
DIN, 1 kHz	4 ohms	—
	6 ohms	80 W + 80 W
	8 ohms	70 W + 70 W
20 Hz – 20 kHz DHT 0,05%	4 ohms	—
	8 ohms	60 W + 60 W

Input

Input jack	Jack type	Sensitivity	Impedance	S/N (weighting network, input level)
PHONO (MM)	Phono	2.0 mV	50 kohms	70 dB (A, 2 mV)
TUNER, CD, VIDEO/AUX, TAPE 1, TAPE 2/DAT	Phono	150 mV	50 kohms	100 dB (150 mV)

Output

Output jack	Jack type	Voltage/impedance
REC OUT	Phono jacks	Voltage 150 mV Impedance 1 kohms
HEAD-PHONES	Stereo phone jack	Accepts low and high impedance headphones.

— Continued on page 2 —



使用時は添付資料も参照のこと
Refer to the additional documents.

INTEGRATED STEREO AMPLIFIER
SONY®

Tone controls

	Response	Turnover frequency
BASS	±8 dB (100 Hz)	500 Hz
TREBLE	±8 dB (15 kHz)	3 kHz

Harmonic distortion

Less than 0.05% at rated output

Intermodulation (IM) distortion (60 Hz:7 kHz = 4:1)

Less than 0.05% at rated output

Frequency response

PHONO: RIAA equalization curve
±0.5 dB

TUNER, CD, VIDEO/AUX, TAPE 1,
TAPE 2/DAT: 7 Hz – 100 kHz ± $\frac{2}{4}$ dB

Residual noise

Less than 170 μ V (network A)

Damping factor

40 (8 ohms, 1 kHz)

General

System

Preamplifier: Low-noise, high-gain equalizer amplifier

Power amplifier: Pure-complementary SEPP
OCL power amplifier with all stages directly coupled

Power requirements

AEP model : 220 V – 230 V AC, 50 Hz
E model : 120 V,
220 V or 240 V AC adjustable,
50/60 Hz

Power consumption

Model for Germany
TA-F417R: 160 W at 230 V AC
Model for Scandinavian countries,
Spain and Portugal
TA-F317R: 130 W at 230 V AC
TA-F417R: 160 W at 230 V AC
Model for other European countries
TA-F317R: 130 W at 230 V AC
TA-F417R: 260 W at 230 V AC
Model for other countries
TA-F417R: 130 W at 230 V AC

Dimensions

Approx. 430 × 135 × 315 mm (w/h/d)
(17 × 5 $\frac{3}{8}$ × 12 $\frac{1}{2}$ inches)

Weight

TA-F317R: Approx. 5.9 kg (13 lb 1 oz)
TA-F417R: Approx. 7.4 kg (16 lb 5 oz)

Accessories

Remote commander RM-S310 (1)
Sony SUM-3 (NS) batteries (2)

Design and specifications subject to change without notice.

Note

This appliance conforms with EEC Directive, 87/308/EEC regarding interference suppression.

TABLE OF CONTENTS

<u>Section</u>	<u>Title</u>	<u>Page</u>
	Specifications	1
	Model Identification	3
	Precautions	3
1. GENERAL		
	Parts Identification	4
2. DISASSEMBLY		6
3. ADJUSTMENTS		6
4. DIAGRAMS		
	4-1. Circuit Boards Location	7
	4-2. Semiconductor Lead Layouts	8
	4-3. Printed Wiring Boards	11
	4-4. Schematic Diagrams (F317R)	15
	4-5. Schematic Diagrams (F417R)	21
5. EXPLODED VIEWS		25
6. ELECTRICAL PARTS LIST		28

MODEL IDENTIFICATION

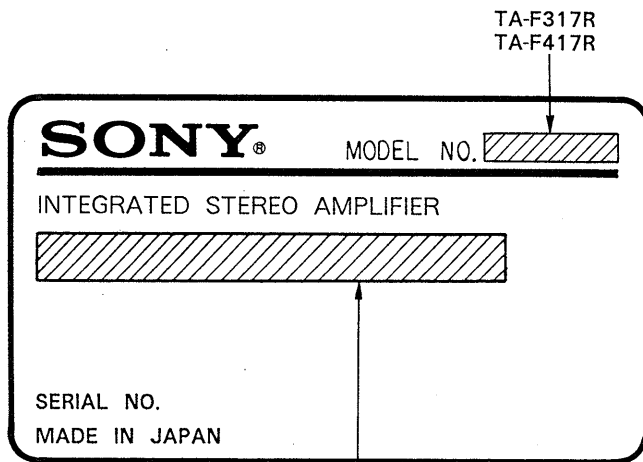

–Model Number Portion–

Printed on panel back



AEP model : TA-F317R/F417R : AC 220V–230V~50/60Hz
 E model : TA-F417R : AC 120/220/240V~50/60Hz 130W

SAFETY-RELATED COMPONENT WARNING!!

COMPONENTS IDENTIFIED BY MARK  OR DOTTED LINE WITH MARK  ON THE SCHEMATIC DIAGRAMS AND IN THE PARTS LIST ARE CRITICAL TO SAFE OPERATION. REPLACE THESE COMPONENTS WITH SONY PARTS WHOSE PART NUMBERS APPEAR AS SHOWN IN THIS MANUAL OR IN SUPPLEMENTS PUBLISHED BY SONY.

Precautions

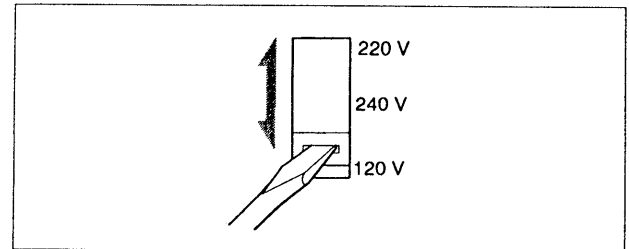

On safety

- Before operating the unit, check that the operating voltage of your unit is identical with the voltage of your local power supply.

Where purchased	Operating voltage
AEP model	220 V – 230 V AC
E model	120 V, 220 V or 240 V AC adjustable The voltage selector is located on the rear panel. If the selector must be reset, disconnect the AC power cord and set the selector to the proper voltage of your local power supply.

- Unplug the unit from the wall outlet if it is not to be used for an extended period of time. To disconnect the cord, pull it out by grasping the plug. Never pull the cord itself.
- Should any solid object or liquid fall into the unit, unplug the unit and have it checked by qualified personnel before operating it any further.
- Do not block the ventilation holes on top of the unit. The ventilation holes must be unobstructed for proper operation of the unit and to prolong the life of its components.
- AC power cord must be changed only at the qualified service shop.

On cleaning the cabinet

Clean the cabinet, panels and controls with a soft cloth lightly moistened with a mild detergent solution. Do not use any type of abrasive pad, scouring powder or solvent such as alcohol or benzine.

On repacking

Do not throw away the carton and the packing material. This makes an ideal container when transporting the unit. When shipping the unit, repack it as it was packed at the factory.

If you have any question or problem concerning your unit, please consult your nearest Sony dealer.

SECTION 1

GENERAL

PARTS IDENTIFICATION

This section is extracted from instruction manual.

TA-F317R

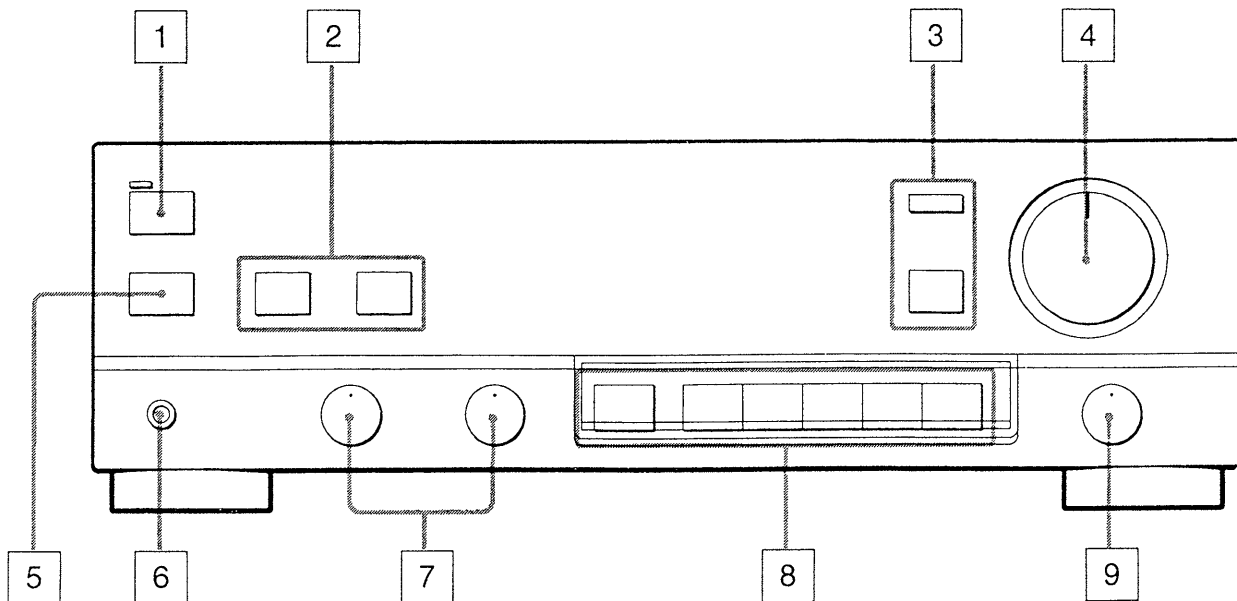

TA-F417R

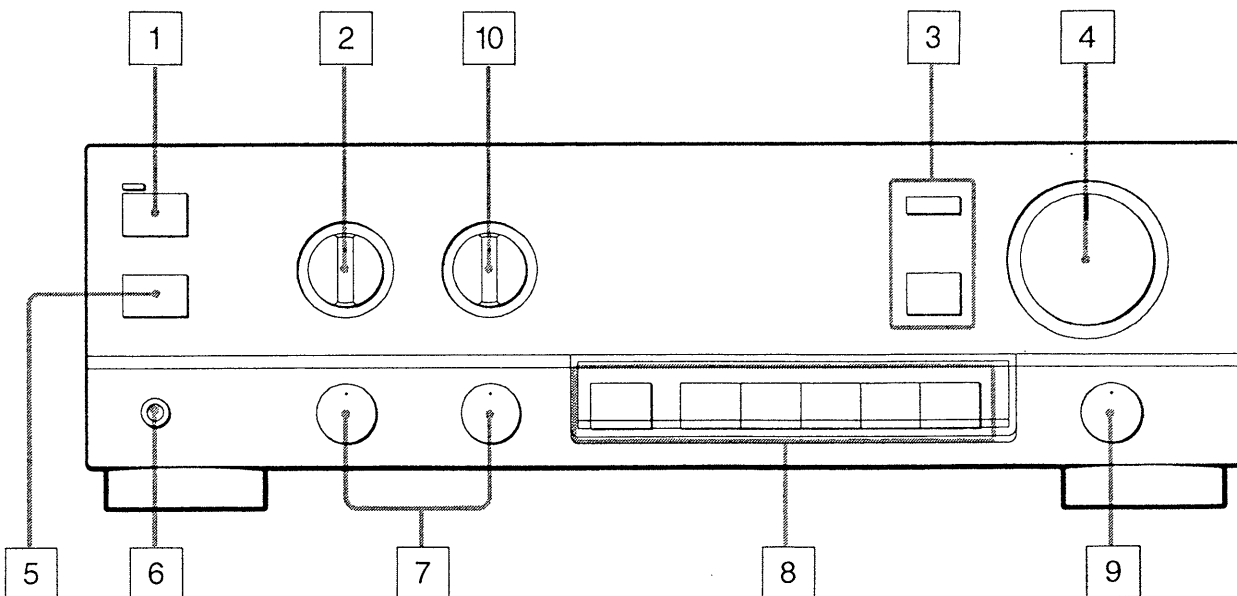

Refer to the pages indicated in ● for details

- 1 POWER switch
- 2 SPEAKERS selector ●
Button selectors for TA-F317R and rotary selector for TA-F417R.
- 3 SOURCE DIRECT switch and indicator ●
- 4 VOLUME control ●
- 5 Remote control sensor
- 6 HEADPHONES jack ●
- 7 TONE controls ●
- 8 INPUT SELECTOR and MONITOR ●
- 9 BALANCE control ●
- 10 REC OUT (Recording output) SELECTOR ●
(TA-F417R only)

Remote commander

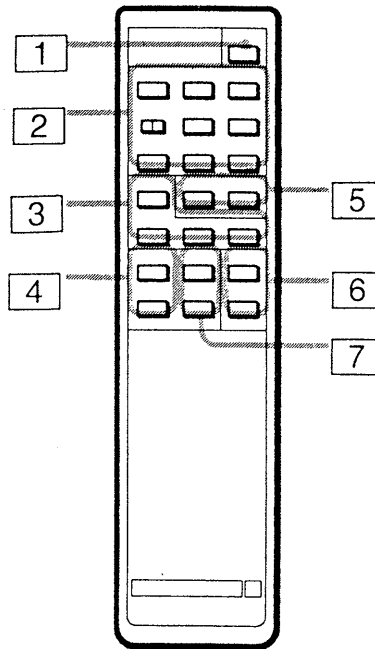

- 1 POWER switch**
- 2 TAPE deck operation buttons**
 - : Stop
 - ◀◀/▶▶: Fast winding
 - DECK A/B: Set this switch to select a deck of a double deck unit.
 - ◀: Reverse play
 - ▶: Forward play
 - Pressing ◀ or ▶ automatically selects TAPE 1 function on the amplifier.
 - ||: Pause
 - : Record muting
 - : Recording
- 3 CD player operation buttons**
 - ▶: Play
 - Pressing ▶ automatically selects CD on the amplifier.
 - : Stop
 - ◀◀/▶▶: Automatic music sensor
- 4 TUNER/VIDEO function buttons**
 - Select TUNER or VIDEO function.
- 5 PHONO (turntable) START/STOP buttons**
 - Pressing START automatically selects PHONO on the amplifier.
- 6 VOL (volume) +/– buttons**
- 7 TUNER PRESET +/– buttons**
 - Press to tune in a preset station.

SECTION 2 DISASSEMBLY

Note: Follow the disassembly procedure in the numerical order given.

1. Remove screws ① ×4.
2. Push leaves ② down to release 4 claws.
3. Release claws ③ in the bottom.
4. Pull front panel in the direction of arrow ④.

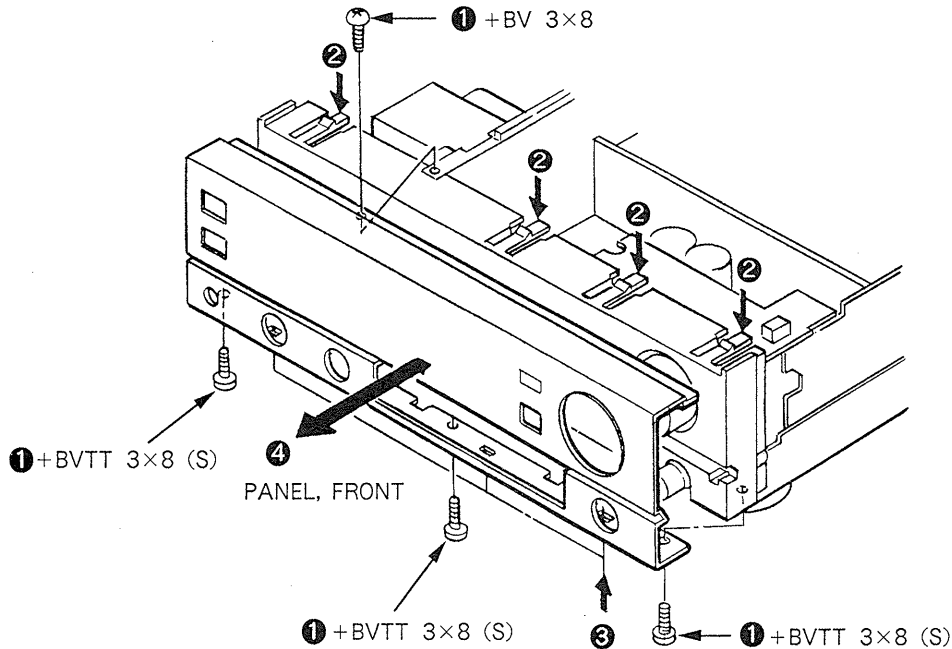

SECTION 3 ADJUSTMENTS

Bias Current Adjustment

Procedure :

1. Set main volume to minimum.
2. Turn the power on and confirm that RY800 will turn on at about 6 seconds after power-on.
3. Adjust RV500 (L-ch) and RV600 (R-ch) so that the voltages across TP500 and TP600 become within the adjustment values.

Adjustment Values :

TA-F317R : $4\text{mV} \pm 0.3\text{mV}$

TA-F417R : $2\text{mV} \pm 0.3\text{mV}$

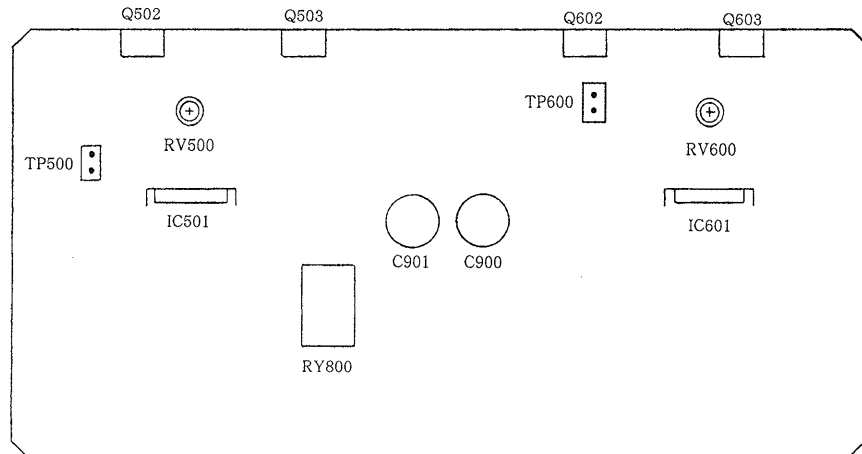
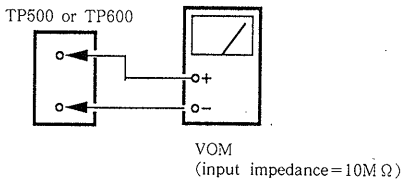

AMP BOARD (COMPONENT SIDE)

SECTION 4 DIAGRAMS

4-1. CIRCUIT BOARDS LOCATION

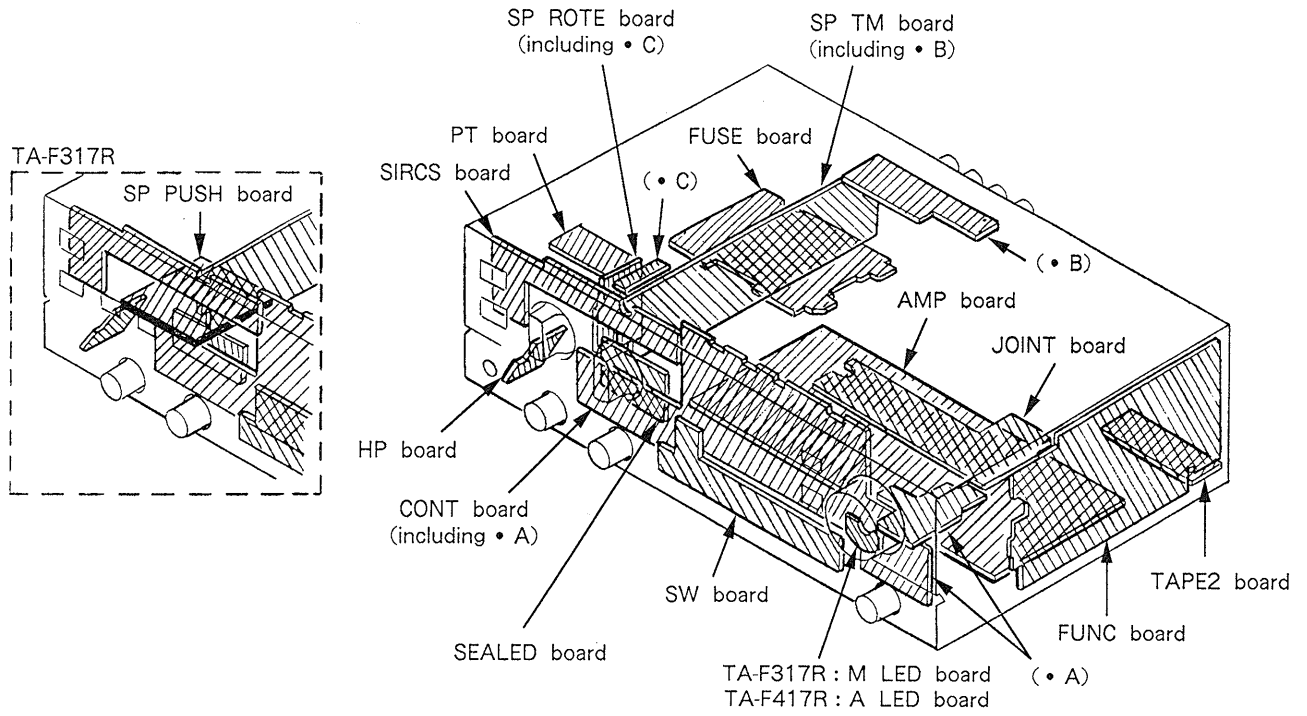

4-2. SEMICONDUCTOR LEAD LAYOUTS

M5F7812L
RC7809FA
TA7805S

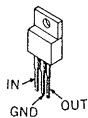

2SA1175-HFE
2SC2785-HFE

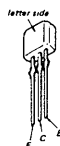

HZ4BLL
1S1585
10E2N

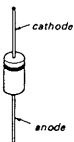

M5F7909L

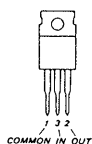

2SA1439LF-OY
2SA1490LF-OY
2SC1841-PAFAEA
2SD1616A-K

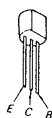

RBA-402
RBV-602-01

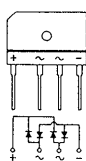

μ PC1237HA

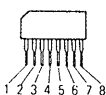

2SB1094-L
2SD2012

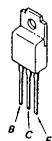

SEL1515C-CD

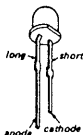

μ PC1298V

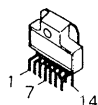

2SB1116-K



SEL1810A

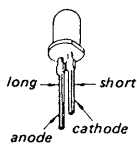

μ PC1342V

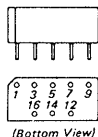

2SC3853LF-OY
2SC3854LF-OY

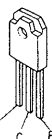

SEL2210S-C
SEL2810A-C

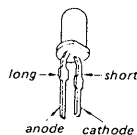

DTA124ES
DTC114ES
DTC124ES
2SC2603-EF
2SC3622A-LK



HZS6A1L
1SS120

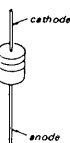

S1VB40

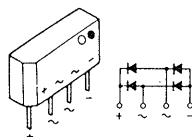

• SEMICONDUCTOR LOCATION
F317R : TA-F317R
F417R : TA-F417R
G : Germany

Ref. No.	Location	Ref. No.	Location
D501	H-21	IC101	C-2
D502	H-22	IC102	G-5
D601	H-16	IC501	I-23
D602	I-16	IC601	I-17
D700	E-23	IC700	E-21
D701	F-20	IC701	G-4
D702	G-2	IC702	E-12
D704	B-30	IC800	J-24
(F317R)		IC900	J-30
D704	(AEP, G)	IC900 (E)	F-30
(F417R)			
D705	E-19	IC901	I-15
D706	E-19	IC902	I-16
D707	E-19	IC950	G-30
D708	E-20		
D709	D-19		
D710	F-20	Q101	H-5
		Q102	H-5
D711	F-20	Q500	J-23
D712	E-20	Q501	G-23
D713	E-20	Q502	G-24
D714	E-20		
D715	C-19	Q503	G-21
		Q504	H-21
D716	C-21	Q600	J-17
D717	C-22	Q601	G-17
D718	C-23	Q602	G-18
D719	C-23		
D720	C-24	Q603	G-16
		Q604	H-16
D721	E-2	Q700	E-23
D722	F-24	Q701	D-22
D723	F-25	Q702	F-19
D724	F-12		
D725	E-2	Q703	F-19
		Q704	D-22
D750	H-4	Q705	D-23
D751	D-20	Q706	K-31
D752	D-20	(AEP, G)	
D753	D-20	Q706 (E)	F-31
D754	D-20		
		Q707	F-2
D755	D-20	Q708	F-2
D756	E-2	Q709	F-2
D757	E-18	Q710	D-19
D758	F-2	Q711	D-19
D800	J-24	Q712	F-20
		Q713	F-20
D801	J-22	Q714	F-20
D802	J-22	Q715	F-21
D900	J-20	Q716	F-22
D901	K-16		
D902	K-16		
		Q717	E-2
D903	K-16	Q750	E-2
D904	K-16	Q751	E-2
D905	J-19	Q761	F-14
D906	H-19	Q762	F-13
D907	I-19		
		Q800	I-25
D908	I-19	Q900	J-18
D909	K-31	Q901	J-19
(AEP, G)			
D909 (E)	G-31		
D913	K-31		
(AEP, G)			
D913 (E)	G-32		
D914	K-31		
(AEP, G)			
D914 (E)	G-32		

Note :
 • : parts extracted from the component side.
 • : Pattern on the side which is seen.
 • Abbreviation
 G : Germany
 F317R : TA-F317R
 F417R : TA-F417R

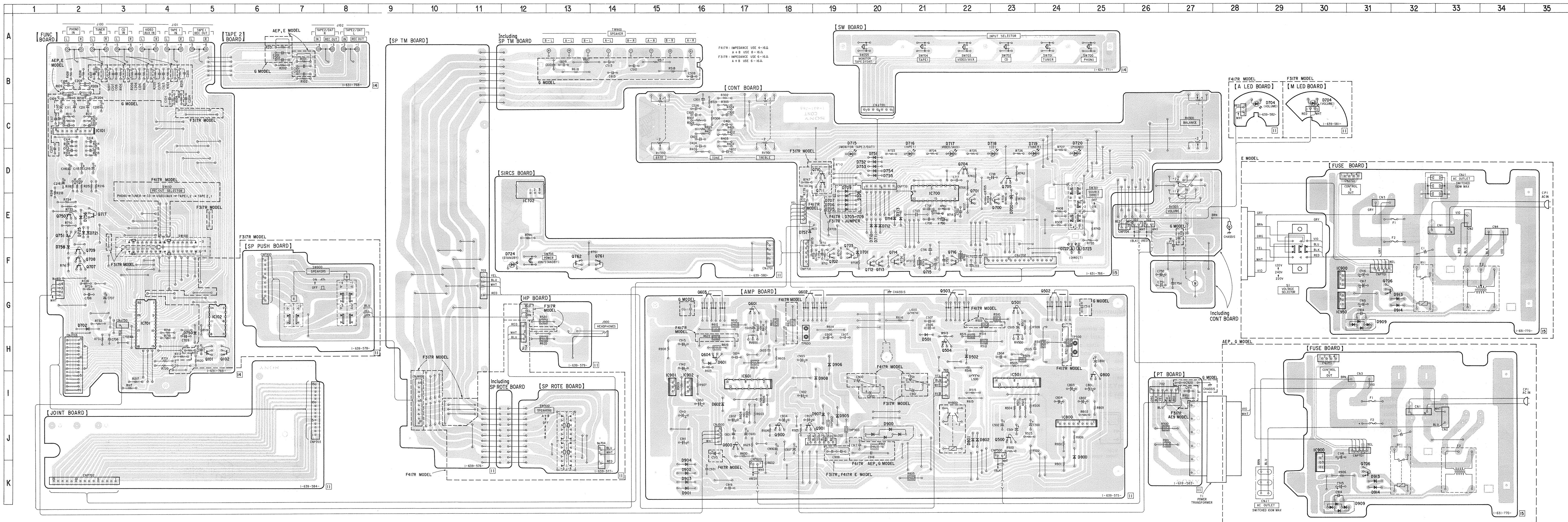

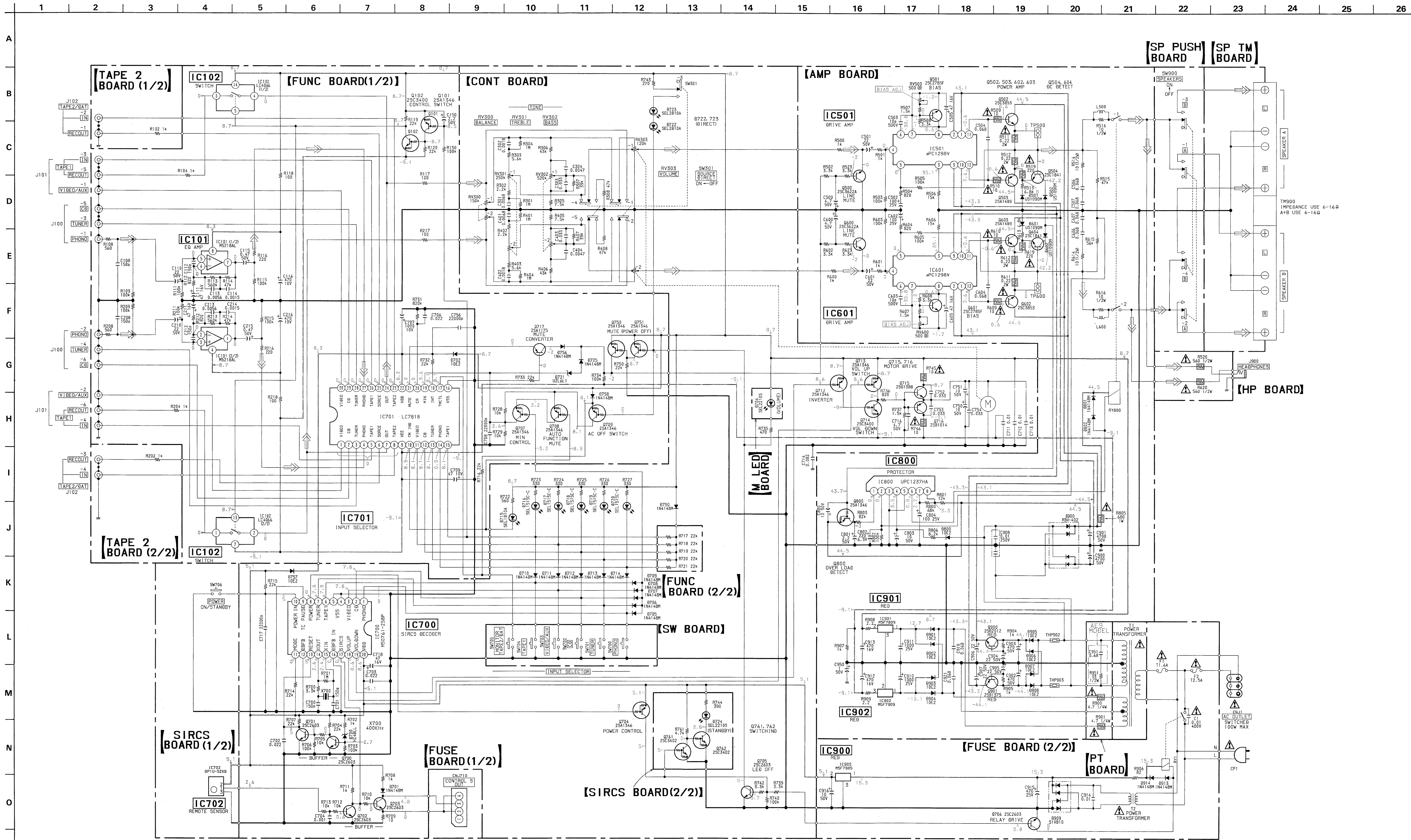

• IC BLOCK DIAGRAMS

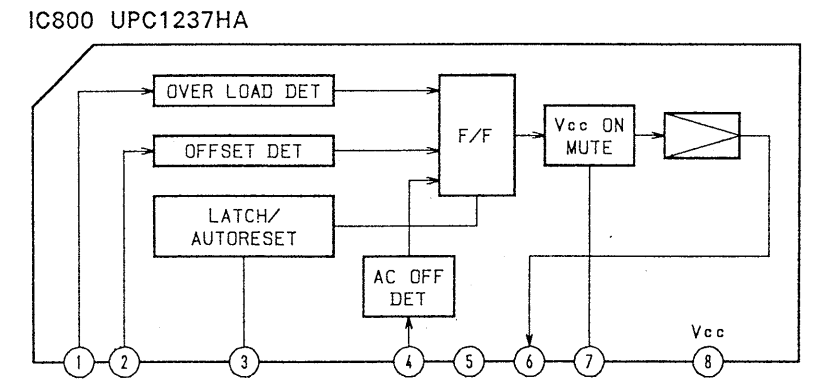
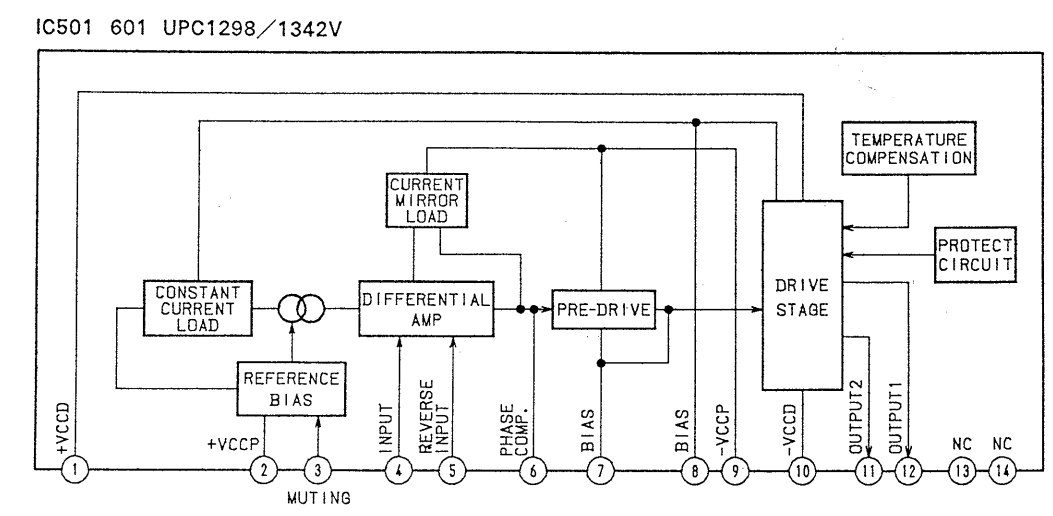

- Note:
- All capacitors are in μF unless otherwise noted. pF: μF 50WV or less are not indicated except for electrolytics and tantalums.
 - All resistors are in Ω and $\frac{1}{2}W$ or less unless otherwise specified.
 - \square : nonflammable resistor.

Note: The components identified by mark Δ or dotted line with mark Δ are critical for safety. Replace only with part number specified.

- $\text{---} \text{---} \text{---}$: B+ Line
- $\text{---} \text{---} \text{---}$: B- Line
- $\text{---} \text{---} \text{---}$: adjustment for repair.
- Voltages are dc with respect to ground under no-signal (detuned) conditions.
- no mark: PHONO
- Voltages are taken with a VOM (input impedance 10M Ω). Voltage variations may be noted due to normal production tolerances.
- Signal path.
- $\text{---} \text{---} \text{---}$: PHONO
- Abbreviation
- G: Germany

• IC BLOCK DIAGRAMS

IC501, 601 UPC1298/1342V

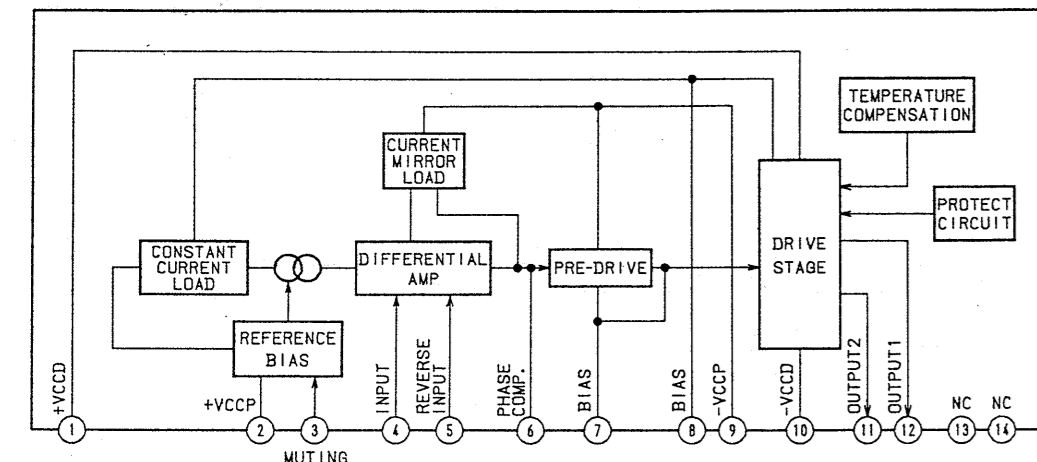

IC800 UPC1237HA

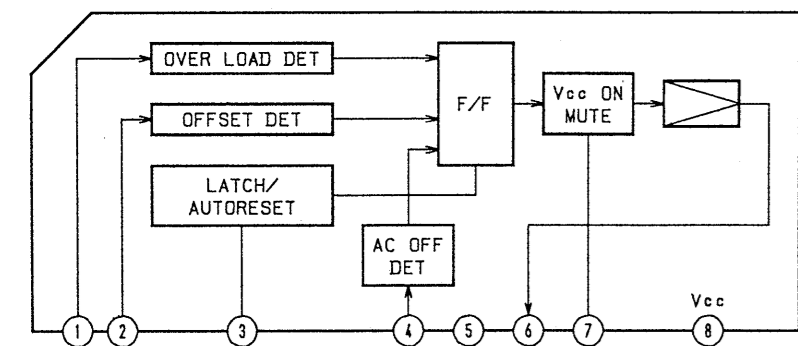

Note:

- All capacitors are in μ F unless otherwise noted. pF: μ F
- 50WV or less are not indicated except for electrolytics and tantalums.
- All resistors are in Ω and $\frac{1}{4}$ W or less unless otherwise specified.
- \square : nonflammable resistor.

Note: The components identified by mark Δ or dotted line with mark Δ are critical for safety. Replace only with part number specified.

- --- : B+ Line
- --- : B- Line
- \square : adjustment for repair.
- Voltage are dc with respect to ground under no-signal (detuned) conditions.
- no mark: PHONO
- Voltagess are taken with a VOM (input impedance 10M Ω)
- Voltage variations may be noted due to normal production tolerances.
- Signal path.
- \Rightarrow : PHONO
- Abbreviation
- G: Germany

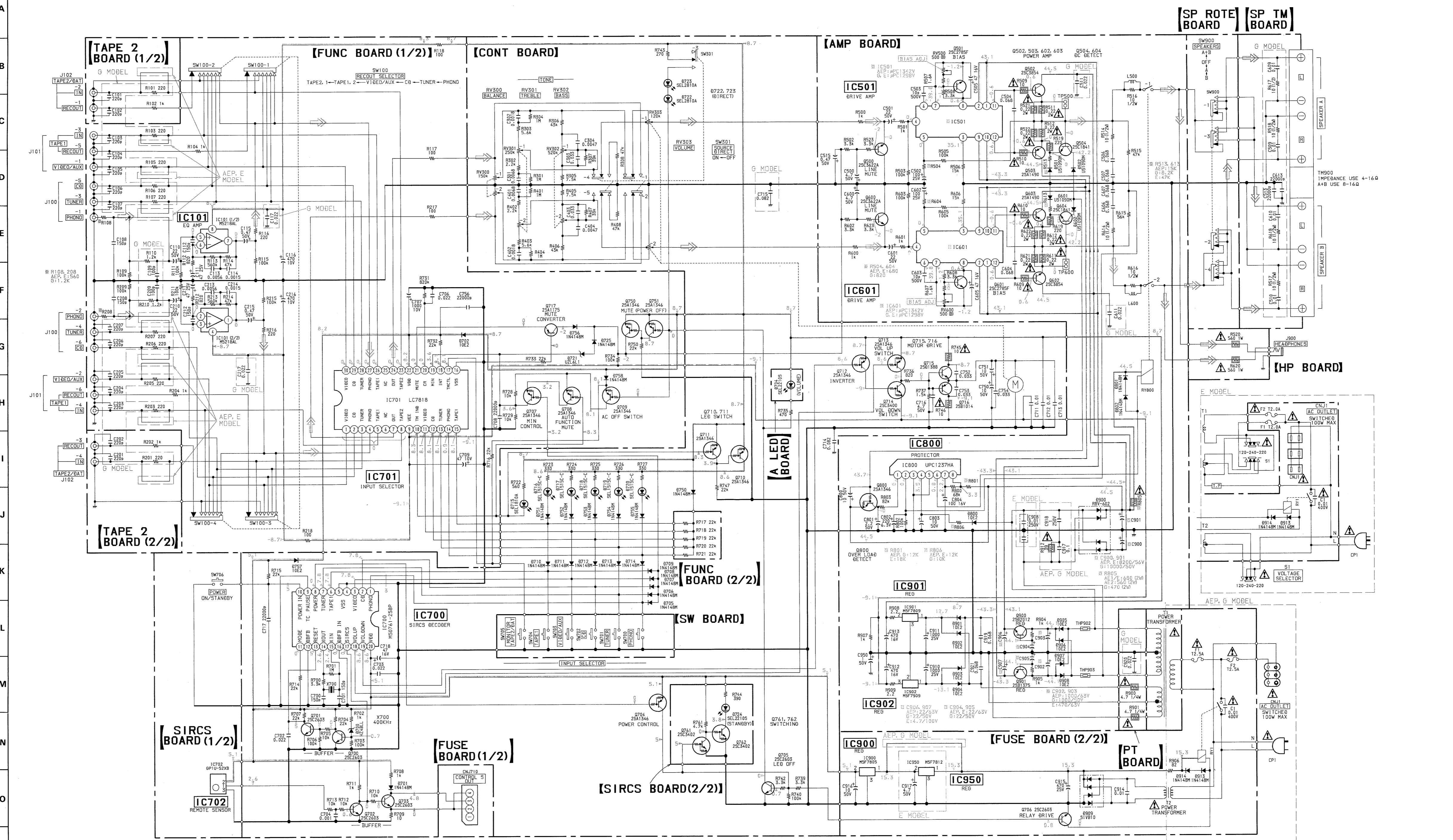

SECTION 5 EXPLODED VIEWS

NOTE:

- -XX, -X mean standardized parts, so they may have some differences from the original one.
- The construction parts of an assembled part are indicated with a collation number in the remark column.
- Color indication of Appearance Parts
Example:
KNOB, BALANCE (WHITE)...(RED)

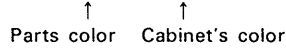

5-1. CABINET SECTION

F317R MODEL

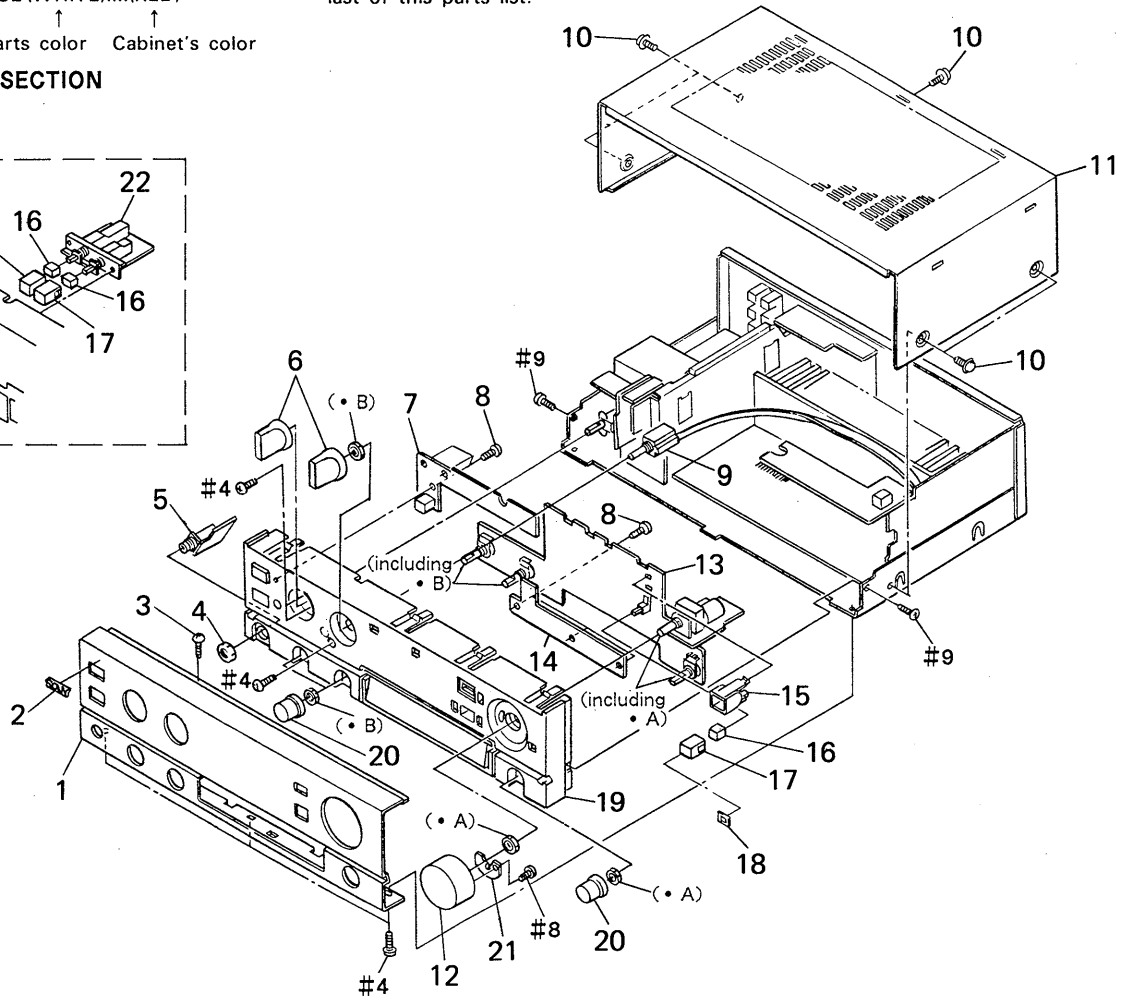
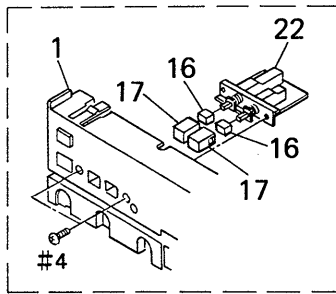

The components identified by mark or dotted line with mark are critical for safety. Replace only with part number specified.

- G : Germany
F317R : TA-F317R
F417R : TA-F417R

- Items marked "*" are not stocked since they are seldom required for routine service. Some delay should be anticipated when ordering these items.
- The mechanical parts with no reference number in the exploded views are not supplied.
- Hardware (#mark) list is given in the last of this parts list.

Ref. No.	Part No.	Description	Remark
1	4-931-915-41	PANEL, FRONT (F417R)	
1	4-931-915-51	PANEL, FRONT (F317R)	
2	4-908-848-01	EMBLEM, SONY	
3	3-703-685-21	SCREW (+BV 3X8)	
4	4-931-902-01	NUT (M12X1)	
5	* 1-639-579-11	HP BOARD	
6	4-945-679-01	KNOB (F29) (F417R)	
7	* 1-639-580-11	SIRCS BOARD	
8	4-928-635-01	SCREW, +BV (2.6X8) TAPPING	
9	1-571-972-11	SWITCH, ROTARY SLIDE (SW100) (F417R:AE1, G, E)	
9	1-571-972-21	SWITCH, ROTARY SLIDE (SW100) (F417R:AE2)	
10	3-704-366-01	SCREW (CASE) (M3X8)	
11	4-929-294-11	CASE	
12	4-929-288-02	KNOB (VOL47) (F317R)	
12	X-4906-828-1	KNOB (47) ASSY (F417R)	

Ref. No.	Part No.	Description	Remark
13	* A-4345-037-A	CONT BOARD, COMPLETE (F417R:AEP, E)	
13	* A-4345-047-A	CONT BOARD, COMPLETE (F417R:G)	
13	* A-4345-095-A	CONT BOARD, COMPLETE (F317R)	
14	* 1-631-771-11	SW BOARD	
15	* 4-921-389-01	HOUSE	
16	4-864-307-00	RING	
17	4-908-875-01	KNOB, SQUARE	
18	4-929-284-01	PLATE, INDICATION	
19	X-4885-966-1	PANEL (BASE) ASSY (F317R)	
19	X-4885-967-1	PANEL (BASE) ASSY (F417R)	
20	4-945-173-01	KNOB (R21) (F317R/F417R:AEP)	
21	* 1-639-582-11	A LED BOARD (F417R)	
21	* 1-639-581-11	M LED BOARD (F317R)	
22	* 1-639-578-11	SP PUSH BOARD (F317R)	

5-2. AMPLIFIER BOARD SECTION

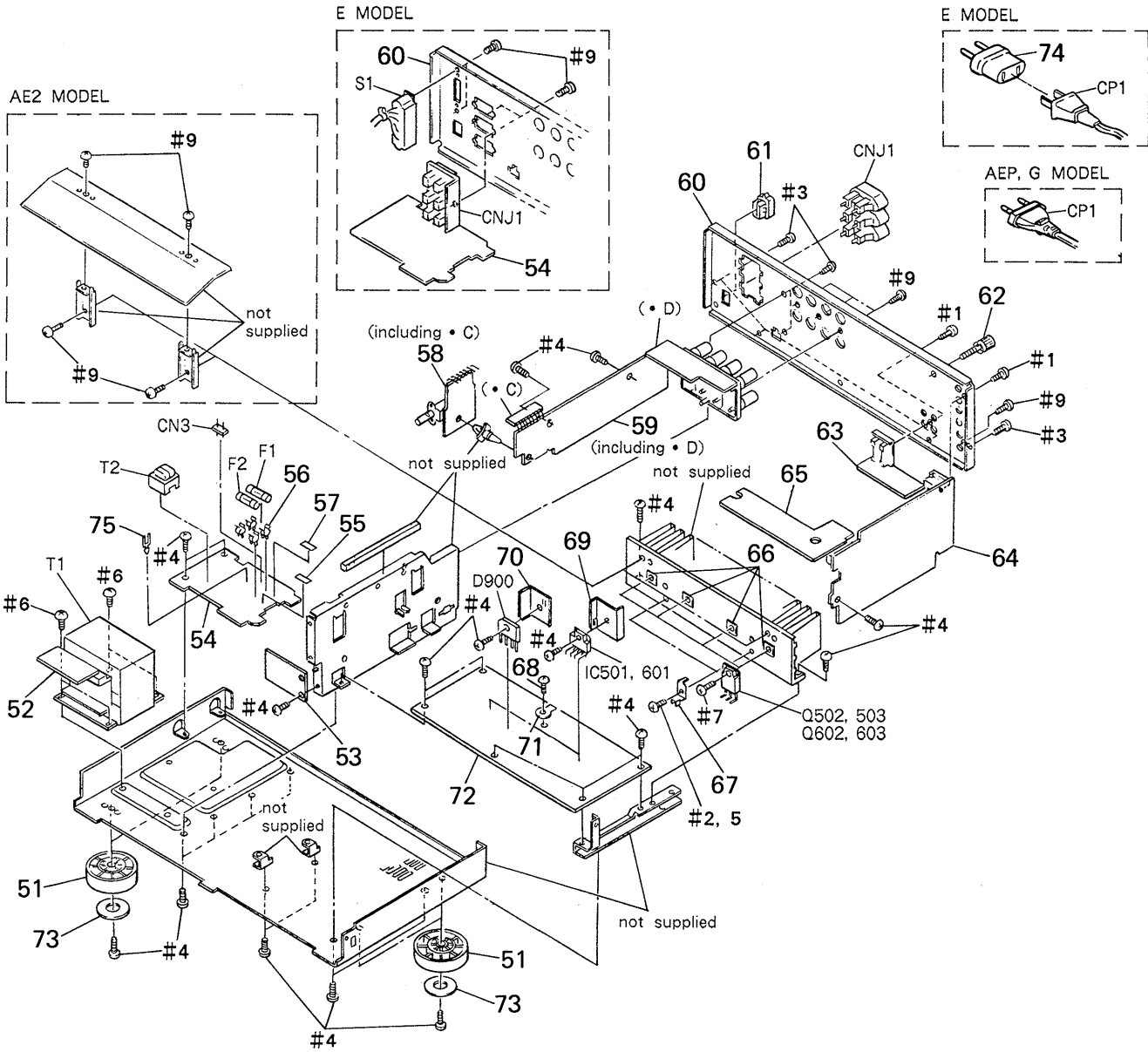

Ref. No.	Part No.	Description	Remark	Ref. No.	Part No.	Description	Remark
51	X-3304-938-2	FOOT ASSY		CN3	* 1-564-321-21	PIN, CONNECTOR 2P	
52	* 1-639-583-11	PT BOARD		CNJ1	△ 1-526-794-11	OUTLET, AC (AC OUTLET)	
53	* 1-631-767-11	SEALED BOARD				(F317R/F417R:AEP, G)	
54	* 1-631-770-11	FUSE BOARD		CNJ1	△ 1-540-042-11	OUTLET, AC (NONPOLAR) (3P) (AC OUTLET)	
55	3-701-947-14	LABEL (T2A), FUSE (F417R:E)				(F417R:E)	
56	* 1-533-213-31	HOLDER, FUSE		CP1	△ 1-574-805-11	CORD, POWER (F317R/F417R:AEP, G)	
57	3-701-947-13	LABEL (T1, 6A), FUSE (F317R)		CP1	△ 1-574-902-11	CORD, POWER (F417R E)	
57	3-701-947-14	LABEL (T2A), FUSE (F417R:E)		D900	8-719-302-38	DIODE RBV-602-01 (F417R)	
58	* 1-639-577-11	SP ROTE BOARD (F417R)		D900	8-719-312-09	DIODE RBA-402 (F317R)	
59	* 1-639-576-11	SP TM BOARD		F1	△ 1-532-203-00	FUSE, TIME-LAG (T2, 0A) (F417R:E)	
60	* 4-945-014-01	PANEL, BACK (F417R:AE1)		F1	△ 1-532-259-00	FUSE, TIME-LAG (T1, 6A) (F317R)	
60	* 4-945-014-11	PANEL, BACK (F417R:AE2)		F1	△ 1-532-286-00	FUSE, TIME-LAG (T2, 5A) (F417R:AEP, G)	
60	* 4-945-014-21	PANEL, BACK (F417R:G)		F2	△ 1-532-203-00	FUSE, TIME-LAG (T2, 0A) (F417R:E)	
60	* 4-945-014-31	PANEL, BACK (F417R:E)		F2	△ 1-532-286-00	FUSE, TIME-LAG (T2, 5A)	
60	* 4-945-014-41	PANEL, BACK (F317R:AE1)				(F317R/F417R:AEP, G)	
60	* 4-945-014-51	PANEL, BACK (F317R:AE9)		IC501	8-759-144-04	IC uPC1342V (F417R:AEP)	
61	* 3-703-244-00	BUSHING (2104), CORD (F317R/F417R:AEP, G)		IC501	8-759-109-06	IC uPC1298V (F317R/F417R:G, E)	
61	* 3-703-571-11	BUSHING (S) (4516), CORD (F417R:E)		IC601	8-759-144-04	IC uPC1342V (F417R:AEP)	
62	3-706-165-00	SCREW		IC601	8-759-109-06	IC uPC1298V (F317R/F417R:G, E)	
63	* 1-631-768-11	TAPE2 BOARD		Q502	8-729-321-99	TRANSISTOR 2SC3854LF-0Y (F417R)	
64	* A-4345-034-A	FUNC BOARD, COMPLETE (F417R:AEP, E)		Q502	8-729-322-08	TRANSISTOR 2SC3853LF-0Y (F317R)	
64	* A-4345-045-A	FUNC BOARD, COMPLETE (F417R:G)		Q503	8-729-322-05	TRANSISTOR 2SA1490LF-0Y (F417R)	
64	* A-4345-093-A	FUNC BOARD, COMPLETE (F317R)		Q503	8-729-322-11	TRANSISTOR 2SA1489LF-0Y (F317R)	
65	* 1-639-584-11	JOINT BOARD		Q602	8-729-321-99	TRANSISTOR 2SC3854LF-0Y (F417R)	
66	4-911-232-01	SHEET, INSULATING		Q602	8-729-322-08	TRANSISTOR 2SC3853LF-0Y (F317R)	
67	* 4-929-285-01	BRACKET (TR)		Q603	8-729-322-05	TRANSISTOR 2SA1490LF-0Y (F417R)	
68	3-703-685-21	SCREW (+BV 3X8)		Q603	8-729-322-11	TRANSISTOR 2SA1489LF-0Y (F317R)	
69	* 4-931-998-01	HEAT SINK (S) (F417R)		S1	△ 1-571-515-11	SWITCH, POWER VOLTAGE SELECTION	
69	* 4-931-998-11	HEAT SINK (S) (F317R)				(F417R:E)	
70	* 4-931-903-01	HEAT SINK (D1) (F417R)		T1	△ 1-449-747-11	TRANSFORMER, POWER (F417R:E)	
71	4-870-539-00	PLATE, GROUND		T1	△ 1-450-551-11	TRANSFORMER, POWER (F317R)	
72	* A-4345-026-A	AMPLIFIER BOARD, COMPLETE (F417R:AE1)		T1	△ 1-450-552-11	TRANSFORMER, POWER (F417R:AE1)	
72	* A-4345-039-A	AMPLIFIER BOARD, COMPLETE (F417R:AE2)		T1	△ 1-450-553-11	TRANSFORMER, POWER (F417R:AE2)	
72	* A-4345-041-A	AMPLIFIER BOARD, COMPLETE (F417R:G)		T1	△ 1-450-554-11	TRANSFORMER, POWER (F417R:G)	
72	* A-4345-049-A	AMPLIFIER BOARD, COMPLETE (F417R:E)		T2	△ 1-449-297-11	TRANSFORMER, POWER (F317R/F417R:AEP, G)	
72	* A-4345-088-A	AMPLIFIER BOARD, COMPLETE (F317R)		T2	△ 1-449-299-11	TRANSFORMER, POWER (F417R:E)	
73	4-923-836-11	CUSHION					
74	△ 1-569-007-11	ADAPTER, CONVERSION 2P (F417R:E)					
75	* 1-535-771-11	TERMINAL (F317R/F417R:AEP, G)					

Note: The components identified by mark △ or dotted line with mark △ are critical for safety. Replace only with part number specified.

SECTION 6 ELECTRICAL PARTS LIST

AMPLIFIER

NOTE:

- Due to standardization, replacements in the parts list may be different from the parts specified in the diagrams or the components used on the set.
- -XX, -X mean standardized parts, so they may have some difference from the original one.
- **RESISTORS**
All resistors are in ohms
METAL : Metal-film resistor
METAL OXIDE : Metal Oxide-film resistor
F : nonflammable

- Items marked "*" are not stocked since they are seldom required for routine service. Some delay should be anticipated when ordering these items.
- **SEMICONDUCTORS**
In each case, u: μ , for example:
uA.....: μ A....., uPA.....: μ PA.....
uPB.....: μ PB....., uPC.....: μ PC.....
uPD.....: μ PD.....
- **CAPACITORS**
uF: μ F
- **COILS**
uH: μ H

The components identified by mark Δ or dotted line with mark Δ are critical for safety. Replace only with part number specified.

When indicating parts by reference number, please include the board name.

- G : Germany
F317R : TA-F317R
F417R : TA-F417R

Ref. No.	Part No.	Description	Remark
* A-4345-026-A		AMPLIFIER BOARD, COMPLETE (F417R:AE1)	
* A-4345-039-A		AMPLIFIER BOARD, COMPLETE (F417R:AE2)	
* A-4345-041-A		AMPLIFIER BOARD, COMPLETE (F417R:G)	
* A-4345-049-A		AMPLIFIER BOARD, COMPLETE (F417R:E)	
* A-4345-088-A		AMPLIFIER BOARD, COMPLETE (F317R)	

* 1-639-576-11		SP TM BOARD	
* 1-639-577-11		SP ROTE BOARD (F417R)	
* 1-639-579-11		HP BOARD	
* 1-639-580-11		SIRCS BOARD	
* 1-639-582-11		A LED BOARD (F417R)	
* 1-639-583-11		PT BOARD	
* 1-639-584-11		JOINT BOARD	
* 1-639-578-11		SP PUSH BOARD (F317R)	
* 1-639-581-11		M LED BOARD (F317R)	
< CAPACITOR >			
C500	1-124-927-11	ELECT 4.7uF	20% 50V
C501	1-126-049-11	ELECT 22uF	20% 50V (F417R)
C501	1-126-233-11	ELECT 22uF	20% 50V (F317R)
C502	1-126-023-11	ELECT 100uF	20% 25V (F417R)
C502	1-124-478-11	ELECT 100uF	20% 25V (F317R)
C503	1-101-804-00	CERAMIC 10PF	5% 500V
C504	1-136-163-00	FILM 0.068uF	5% 50V
C505	1-124-477-11	ELECT 47uF	20% 16V
C506	1-136-163-00	FILM 0.068uF	5% 50V
C507	1-136-163-00	FILM 0.068uF	5% 50V
C509	1-136-153-00	FILM 0.01uF	5% 50V (F417R:G)
C510	1-136-153-00	FILM 0.01uF	5% 50V (F417R:G)
C511	1-136-157-00	FILM 0.022uF	5% 50V (F417R:G)
C513	1-164-097-11	CERAMIC 0.022uF	50V (F417R:G)
C515	1-124-902-11	ELECT 0.47uF	50V (F417R)
C600	1-124-927-11	ELECT 4.7uF	20% 50V

Ref. No.	Part No.	Description	Remark
C601	1-126-049-11	ELECT 22uF	20% 50V (F417R)
C601	1-126-233-11	ELECT 22uF	20% 50V (F317R)
C602	1-126-023-11	ELECT 100uF	20% 25V (F417R)
C602	1-124-478-11	ELECT 100uF	20% 25V (F317R)
C603	1-101-804-00	CERAMIC 10PF	5% 500V
C604	1-136-163-00	FILM 0.068uF	5% 50V
C605	1-124-477-11	ELECT 47uF	20% 16V
C606	1-136-163-00	FILM 0.068uF	5% 50V
C607	1-136-163-00	FILM 0.068uF	5% 50V
C609	1-136-153-00	FILM 0.01uF	5% 50V (F417R:G)
C610	1-136-153-00	FILM 0.01uF	5% 50V (F417R:G)
C611	1-136-157-00	FILM 0.022uF	5% 50V (F417R:G)
C613	1-164-097-11	CERAMIC 0.022uF	50V (F417R:G)
C800	1-124-907-11	ELECT 10uF	20% 50V
C801	1-124-925-11	ELECT 2.2uF	20% 50V
C802	1-126-176-11	ELECT 220uF	20% 6.3V
C803	1-124-907-11	ELECT 10uF	20% 50V
C804	1-126-101-11	ELECT 100uF	20% 16V (F417R)
C804	1-124-478-11	ELECT 100uF	20% 25V (F317R)
C900	1-125-574-11	ELECT 8200uF	20% 56V (F417R:AEP)
C900	1-125-536-11	ELECT 10000uF	20% 50V (F417R:G)
C900	1-125-556-11	ELECT (BLOCK) 8200uF	20% 56V (F417R:E)
C900	1-126-138-11	ELECT 4700uF	20% 50V (F317R)
C901	1-125-574-11	ELECT 8200uF	20% 56V (F417R:AEP)
C901	1-125-536-11	ELECT 10000uF	20% 50V (F417R:G)
C901	1-125-556-11	ELECT (BLOCK) 8200uF	20% 56V (F417R:E)
C901	1-126-138-11	ELECT 4700uF	20% 50V (F317R)

AMPLIFIER

Ref. No.	Part No.	Description	Remark			Ref. No.	Part No.	Description	Remark		
C902	1-126-067-11	ELECT	1000uF	20%	63V (F417R:AEP)	C917	1-136-165-00	FILM	0.1uF	5%	50V
C902	1-124-637-11	ELECT	1000uF	20%	50V (F417R:G)						(F417R:AEP, G)
C902	1-124-921-11	ELECT	470uF	20%	63V (F417R:E)	C918	1-130-798-00	FILM	1uF	10%	250V
C902	1-124-913-11	ELECT	470uF	20%	50V (F317R)						(F417R:AEP, G)
C903	1-126-067-11	ELECT	1000uF		20% 63V (F417R:AEP)	C919	1-136-163-00	FILM	0.068uF	5%	50V
C903	1-124-637-11	ELECT	1000uF		20% 50V (F417R:G)	C920	1-136-157-00	FILM	0.022uF	5%	50V
C903	1-124-921-11	ELECT	470uF		20% 63V (F417R:E)						(F417R:G)
C903	1-124-913-11	ELECT	470uF		20% 50V (F317R)	C921	1-136-163-00	FILM	0.068uF	5%	50V
C904	1-124-916-11	ELECT	22uF		20% 63V (F417R:AEP, E)	C950	1-124-903-11	ELECT	1uF	20%	50V
C904	1-126-233-11	ELECT	22uF		20% 50V (F317R/F417R:G)	C951	1-136-175-00	FILM	0.68uF	5%	50V
C905	1-124-916-11	ELECT	22uF		20% 63V (F417R:AEP, E)						(F317R:AE9)
C905	1-126-233-11	ELECT	22uF		20% 50V (F317R/F417R:G)	< CONNECTOR >					
C906	1-124-916-11	ELECT	22uF		20% 63V (F417R:AEP)	CNJ500 *	1-564-338-00	PIN, CONNECTOR 4P			
C906	1-126-233-11	ELECT	22uF		20% 50V (F317R/F417R:G)	CNJ900	1-508-693-00	CONNECTOR PIN 10P (F317R)			
C906	1-124-927-11	ELECT	4.7uF		20% 100V (F417R:E)	CNJ900	1-568-649-11	SOCKET, CONNECTOR 10P (F317R)			
C907	1-124-916-11	ELECT	22uF		20% 63V (F417R:AEP)	CNP600 *	1-564-505-11	PLUG, CONNECTOR 2P			
C907	1-126-233-11	ELECT	22uF		20% 50V (F317R/F417R:G)	CNP702 *	1-568-647-11	PIN, CONNECTOR 15P			
C907	1-124-927-11	ELECT	4.7uF		20% 100V (F417R:E)	CNP703	1-568-645-11	1IN, CONNECTOR (PC BOARD) 15P			
C908	1-102-394-11	CERAMIC	0.01uF		250V (F317R/F417R:E)	< DIODE >					
C910	1-126-027-11	ELECT	1000uF		20% 25V (F417R:AEP, G)	D501	8-719-815-85	DIODE 1S1585			
C910	1-124-557-11	ELECT	1000uF		20% 25V (F317R/F417R:E)	D502	8-719-815-85	DIODE 1S1585			
C911	1-126-027-11	ELECT	1000uF		20% 25V (F417R:AEP, G)	D601	8-719-815-85	DIODE 1S1585			
C911	1-124-557-11	ELECT	1000uF		20% 25V (F317R/F417R:E)	D602	8-719-815-85	DIODE 1S1585			
C912	1-126-012-11	ELECT	470uF	20%	16V (F417R)	D704	8-719-301-38	DIODE SEL2210S-C (VOLUME)			
C912	1-126-103-11	ELECT	470uF	20%	16V (F317R)	D724	8-719-301-38	DIODE SEL2210S-C (STANDBY)			
C913	1-126-012-11	ELECT	470uF	20%	16V (F417R)	D800	8-719-200-77	DIODE 10E2N			
C913	1-126-103-11	ELECT	470uF	20%	16V (F317R)	D801	8-719-912-20	DIODE 1SS120			
						D802	8-719-912-20	DIODE 1SS120			
						D900	8-719-302-38	DIODE RBV-602-01 (F417R)			
						D900	8-719-312-09	DIODE RBA-402 (F317R)			
						D901	8-719-200-77	DIODE 10E2N			
						D902	8-719-200-77	DIODE 10E2N			
						D903	8-719-200-77	DIODE 10E2N			
						D904	8-719-200-77	DIODE 10E2N			
						D905	8-719-200-77	DIODE 10E2N			
						D906	8-719-200-77	DIODE 10E2N			
						D907	8-719-200-77	DIODE 10E2N			
						D908	8-719-200-77	DIODE 10E2N			
						< IC >					
						IC501	8-759-144-04	IC uPC1342V (F417R:AEP)			
						IC501	8-759-109-06	IC uPC1298V (F317R/F417R:G, E)			
						IC601	8-759-144-04	IC uPC1342V (F417R:AEP)			
						IC601	8-759-109-06	IC uPC1298V (F317R/F417R:G, E)			
						IC702	8-749-920-83	IC GP1U52XB			

AMPLIFIER

Ref. No.	Part No.	Description	Remark
IC800	8-759-111-68	IC uPC1237HA	
IC901	8-759-982-10	IC RC7809FA	
IC902	8-759-604-49	IC M5F7909L	
< JACK >			
J900	1-507-863-51	JACK, PHONE (HAEDPHONES)	
< COIL >			
L500	* 1-420-872-00	COIL, AIR CORE	
L600	* 1-420-872-00	COIL, AIR CORE	
< TRANSISTOR >			
Q500	8-729-141-26	TRANSISTOR 2SC3622A-LK	
Q501	8-729-119-78	TRANSISTOR 2SC2785-HFE	
Q502	8-729-321-99	TRANSISTOR 2SC3854LF-OY (F417R)	
Q502	8-729-322-08	TRANSISTOR 2SC3853LF-OY (F317R)	
Q503	8-729-322-05	TRANSISTOR 2SA1490LF-OY (F417R)	
Q503	8-729-322-11	TRANSISTOR 2SA1489LF-OY (F317R)	
Q504	8-729-140-84	TRANSISTOR 2SC1841-PAFAEA	
Q600	8-729-141-26	TRANSISTOR 2SC3622A-LK	
Q601	8-729-119-78	TRANSISTOR 2SC2785-HFE	
Q602	8-729-321-99	TRANSISTOR 2SC3854LF-OY (F417R)	
Q602	8-729-322-08	TRANSISTOR 2SC3853LF-OY (F317R)	
Q603	8-729-322-05	TRANSISTOR 2SA1490LF-OY (F417R)	
Q603	8-729-322-11	TRANSISTOR 2SA1489LF-OY (F317R)	
Q604	8-729-140-84	TRANSISTOR 2SC1841-PAFAEA	
Q761	8-729-900-80	TRANSISTOR DTC114ES	
Q762	8-729-900-80	TRANSISTOR DTC114ES	
Q800	8-729-900-63	TRANSISTOR DTA124ES	
Q900	8-729-209-15	TRANSISTOR 2SD2012	
Q901	8-729-111-67	TRANSISTOR 2SB1094-L	
< RESISTOR >			
R500	1-247-713-11	CARBON 1K	5% 1/4W (F417R)
R500	1-249-417-11	CARBON 1K	5% 1/4W (F317R)
R501	1-247-713-11	CARBON 1K	5% 1/4W (F417R)
R501	1-249-417-11	CARBON 1K	5% 1/4W (F317R)
R502	1-249-423-11	CARBON 3.3K	5% 1/4W
R503	1-249-469-11	CARBON 100K	5% 1/4W (F417R)
R503	1-249-441-11	CARBON 100K	5% 1/4W (F317R)
R504	1-247-711-11	CARBON 680	5% 1/4W (F417R: AEP, E)
R504	1-247-712-11	CARBON 820	5% 1/4W (F417R: G)
R504	1-249-416-11	CARBON 820	5% 1/4W (F317R)

Ref. No.	Part No.	Description	Remark
R505	1-249-469-11	CARBON 100K	5% 1/4W (F417R)
R505	1-249-441-11	CARBON 100K	5% 1/4W (F317R)
R506	1-249-431-11	CARBON 15K	5% 1/4W
R507	1-247-836-11	CARBON 1.6K	5% 1/4W (F417R)
R507	1-249-419-11	CARBON 1.5K	5% 1/4W (F317R)
R508	1-249-423-11	CARBON 3.3K	5% 1/4W
R509	△ 1-247-688-11	CARBON 10	5% 1/4W F
R510	△ 1-247-688-11	CARBON 10	5% 1/4W F
R511	△ 1-216-361-00	METAL OXIDE 0.22	5% 2W F
R512	△ 1-216-361-00	METAL OXIDE 0.22	5% 2W F
R513	1-249-431-11	CARBON 15K	5% 1/4W (F417R: AEP)
R513	1-249-428-11	CARBON 8.2K	5% 1/4W (F417R: G)
R513	1-249-437-11	CARBON 47K	5% 1/4W (F417R: E)
R513	1-249-427-11	CARBON 6.8K	5% 1/4W (F317R)
R514	1-247-727-11	CARBON 10	5% 1/2W
R515	1-249-437-11	CARBON 47K	5% 1/4W
R516	1-247-727-11	CARBON 10	5% 1/2W
R517	1-247-727-11	CARBON 10	5% 1/2W (F417R: G)
R518	1-247-727-11	CARBON 10	5% 1/2W (F417R: G)
R519	△ 1-247-704-11	CARBON 220	5% 1/4W F
R520	△ 1-216-431-11	METAL OXIDE 560	5% 1W F (F417R)
R520	△ 1-247-749-11	CARBON 560	5% 1/2W F (F317R)
R521	△ 1-216-361-00	METAL OXIDE 0.22	5% 2W F (F417R)
R522	△ 1-216-361-00	METAL OXIDE 0.22	5% 2W F (F417R)
R523	1-249-423-11	CARBON 3.3K	5% 1/4W
R600	1-247-713-11	CARBON 1K	5% 1/4W (F417R)
R600	1-249-417-11	CARBON 1K	5% 1/4W (F317R)
R601	1-247-713-11	CARBON 1K	5% 1/4W (F417R)
R601	1-249-417-11	CARBON 1K	5% 1/4W (F317R)
R602	1-249-423-11	CARBON 3.3K	5% 1/4W
R603	1-249-469-11	CARBON 100K	5% 1/4W (F417R)
R603	1-249-441-11	CARBON 100K	5% 1/4W (F317R)
R604	1-247-711-11	CARBON 680	5% 1/4W (F417R: AEP, E)
R604	1-247-712-11	CARBON 820	5% 1/4W (F417R: G)
R604	1-249-416-11	CARBON 820	5% 1/4W (F317R)
R605	1-249-469-11	CARBON 100K	5% 1/4W (F417R)
R605	1-249-441-11	CARBON 100K	5% 1/4W (F317R)
R606	1-249-431-11	CARBON 15K	5% 1/4W
R607	1-247-836-11	CARBON 1.6K	5% 1/4W (F417R)
R607	1-249-419-11	CARBON 1.5K	5% 1/4W (F317R)
R608	1-249-423-11	CARBON 3.3K	5% 1/4W

Note: The components identified by mark △ or dotted line with mark △ are critical for safety. Replace only with part number specified.

AMPLIFIER **CONTROL** **FUNC**

Ref. No.	Part No.	Description	Remark			
R609	△ 1-247-688-11	CARBON	10	5%	1/4W	F
R610	△ 1-247-688-11	CARBON	10	5%	1/4W	F
R611	△ 1-216-361-00	METAL OXIDE	0.22	5%	2W	F
R612	△ 1-216-361-00	METAL OXIDE	0.22	5%	2W	F
R613	1-249-431-11	CARBON	15K	5%	1/4W	(F417R:AEP)
R613	1-249-428-11	CARBON	8.2K	5%	1/4W	(F417R:G)
R613	1-249-437-11	CARBON	47K	5%	1/4W	(F417R:E)
R613	1-249-427-11	CARBON	6.8K	5%	1/4W	(F317R)
R614	1-247-727-11	CARBON	10	5%	1/2W	
R615	1-249-438-11	CARBON	56K	5%	1/4W	
R616	1-247-727-11	CARBON	10	5%	1/2W	
R617	1-247-727-11	CARBON	10	5%	1/2W	(F417R:G)
R618	1-247-727-11	CARBON	10	5%	1/2W	(F417R:G)
R619	△ 1-247-704-11	CARBON	220	5%	1/4W	F
R620	△ 1-216-431-11	METAL OXIDE	560	5%	1W	F (F417R)
R620	△ 1-247-749-11	CARBON	560	5%	1/2W	F (F317R)
R621	△ 1-216-361-00	METAL OXIDE	0.22	5%	2W	F (F417R)
R622	△ 1-216-361-00	METAL OXIDE	0.22	5%	2W	F (F417R)
R623	1-249-423-11	CARBON	3.3K	5%	1/4W	
R744	1-249-412-11	CARBON	390	5%	1/4W	
R761	1-249-425-11	CARBON	4.7K	5%	1/4W	
R800	1-249-439-11	CARBON	68K	5%	1/4W	
R801	1-249-430-11	CARBON	12K	5%	1/4W	(F317R/F417R:AEP, G)
R801	1-249-432-11	CARBON	18K	5%	1/4W	(F417R:E)
R802	1-249-441-11	CARBON	100K	5%	1/4W	
R803	1-249-440-11	CARBON	82K	5%	1/4W	
R805	△ 1-215-891-11	METAL OXIDE	680	5%	2W	F (F417R:AE1, E)
R805	△ 1-216-455-11	METAL OXIDE	560	5%	2W	F (F417R:AE2)
R805	△ 1-215-890-11	METAL OXIDE	470	5%	2W	F (F417R:G)
R805	△ 1-215-868-00	METAL OXIDE	680	5%	1W	F (F317R)
R806	1-249-430-11	CARBON	12K	5%	1/4W	(F417R:AEP, E)
R806	1-249-429-11	CARBON	10K	5%	1/4W	(F417R:G)
R806	1-249-428-11	CARBON	8.2K	5%	1/4W	(F317R)
R900	△ 1-249-455-11	CARBON	4.7	5%	1/4W	F
R901	△ 1-249-455-11	CARBON	4.7	5%	1/4W	F
R904	1-249-417-11	CARBON	1K	5%	1/4W	
R905	1-249-417-11	CARBON	1K	5%	1/4W	
R907	1-247-713-11	CARBON	1K	5%	1/4W	
R908	1-249-451-11	CARBON	2.2	5%	1/4W	
R909	1-249-451-11	CARBON	2.2	5%	1/4W	
R912	△ 1-247-695-11	CARBON	39	5%	1/4W	F (F417R:AEP, G)
R951	1-244-837-11	CARBON	33	5%	1/2W	(F317R:AE9)

Ref. No.	Part No.	Description	Remark	
		< VARIABLE RESISTOR >		
RV500	1-237-455-11	RES, ADJ. CARBON	500	
RV600	1-237-455-11	RES, ADJ. CARBON	500	
		< RELAY >		
RY800	1-515-501-00	RELAY (F417R)		
RY800	1-515-533-11	RELAY (F317R)		
		< SWITCH >		
SW706	1-554-303-21	SWITCH, TACTILE (POWER)		
SW900	1-571-973-11	SWITCH, ROTARY (SPEAKERS)	(F417R)	
SW900	1-571-971-11	SWITCH, PUSH (2 KEY)	(SPEAKERS A/B)	(F317R)
		< THERMISTOR >		
THP902	1-806-882-11	THERMISTOR (POSITIVE)		
THP903	1-806-882-11	THERMISTOR (POSITIVE)		
		< TERMINAL >		
TM900	1-537-228-11	TERMINAL BOARD (SP)	(SPEAKER)	(F317R:AE1/F417R:AE1, G, E)
TM900	1-537-227-11	TERMINAL BOARD (SP)	(SPEAKER)	(F317R:AE9/F417R:AE2)
TP500	* 1-535-115-00	TERMINAL		
TP600	* 1-535-115-00	TERMINAL		

* A-4345-037-A CONTROL BOARD, COMPLETE (F417R:AEP, E)				
* A-4345-047-A CONTROL BOARD, COMPLETE (F417R:G)				
* A-4345-095-A CONTROL BOARD, COMPLETE (F317R)				

* A-4345-034-A FUNC BOARD, COMPLETE (F417R:AEP, E)				
* A-4345-045-A FUNC BOARD, COMPLETE (F417R:G)				
* A-4345-093-A FUNC BOARD, COMPLETE (F317R)				

* 1-631-767-11 SEALED BOARD				
* 1-631-768-11 TAPE2 BOARD				
* 1-631-770-11 FUSE BOARD				
* 1-631-771-11 SW BOARD				
		< CAPACITOR >		
C1	△ 1-161-744-00	CERAMIC	0.01uF	400V
C101	1-162-286-31	CERAMIC	220PF	10% 50V (F417R:G)
C102	1-162-286-31	CERAMIC	220PF	10% 50V (F417R:G)
C103	1-162-286-31	CERAMIC	220PF	10% 50V (F417R:G)
C104	1-162-286-31	CERAMIC	220PF	10% 50V (F417R:G)

Note: The components identified by mark **△** or dotted line with mark **△** are critical for safety. Replace only with part number specified.

CONTROL



FUNC

Ref. No.	Part No.	Description	Remark
C105	1-162-286-31	CERAMIC 220PF 10% 50V (F417R:G)	
C106	1-162-286-31	CERAMIC 220PF 10% 50V (F417R:G)	
C107	1-162-286-31	CERAMIC 220PF 10% 50V (F417R:G)	
C108	1-162-284-31	CERAMIC 150PF 10% 50V	
C109	1-162-282-31	CERAMIC 100PF 10% 50V (F417R:G)	
C110	1-126-049-11	ELECT 22uF 20% 50V (F417R)	
C110	1-126-233-11	ELECT 22uF 20% 50V (F317R)	
C111	1-124-477-11	ELECT 47uF 20% 16V (F317R)	
C111	1-126-022-11	ELECT 47uF 20% 25V (F417R)	
C112	1-162-284-31	CERAMIC 150PF 10% 50V	
C113	1-130-480-00	MYLAR 0.0056uF 5% 50V	
C114	1-130-473-00	MYLAR 0.0015uF 5% 50V	
C115	1-126-043-11	ELECT 0.47uF 20% 50V (F417R)	
C115	1-124-902-00	ELECT 0.47uF 20% 50V (F317R)	
C116	1-124-997-11	ELECT 470uF 20% 10V (F417R)	
C116	1-124-472-11	ELECT 470uF 20% 10V (F317R)	
C117	1-136-157-00	FILM 0.022uF 5% 50V (F417R:G)	
C150	1-124-925-11	ELECT 2.2uF 20% 50V (F317R)	
C201	1-162-286-31	CERAMIC 220PF 10% 50V (F417R:G)	
C202	1-162-286-31	CERAMIC 220PF 10% 50V (F417R:G)	
C203	1-162-286-31	CERAMIC 220PF 10% 50V (F417R:G)	
C204	1-162-286-31	CERAMIC 220PF 10% 50V (F417R:G)	
C205	1-162-286-31	CERAMIC 220PF 10% 50V (F417R:G)	
C206	1-162-286-31	CERAMIC 220PF 10% 50V (F417R:G)	
C207	1-162-286-31	CERAMIC 220PF 10% 50V (F417R:G)	
C208	1-162-284-31	CERAMIC 150PF 10% 50V	
C209	1-162-282-31	CERAMIC 100PF 10% 50V (F417R:G)	
C210	1-126-049-11	ELECT 22uF 20% 50V (F417R)	
C210	1-126-233-11	ELECT 22uF 20% 50V (F317R)	
C211	1-126-022-11	ELECT 47uF 20% 25V (F417R)	
C211	1-124-477-11	ELECT 47uF 20% 16V (F317R)	
C212	1-162-284-31	CERAMIC 150PF 10% 50V	
C213	1-130-480-00	MYLAR 0.0056uF 5% 50V	
C214	1-130-473-00	MYLAR 0.0015uF 5% 50V	
C215	1-126-043-11	ELECT 0.47uF 20% 50V (F417R)	
C215	1-124-902-00	ELECT 0.47uF 20% 50V (F317R)	
C216	1-124-997-11	ELECT 470uF 20% 10V (F417R)	
C216	1-124-472-11	ELECT 470uF 20% 10V (F317R)	
C217	1-136-157-00	FILM 0.022uF 5% 50V (F417R:G)	
C301	1-130-481-00	MYLAR 0.0068uF 5% 50V	
C302	1-130-474-00	MYLAR 0.0018uF 5% 50V	
C303	1-136-159-00	FILM 0.033uF 5% 50V	
C304	1-130-479-00	MYLAR 0.0047uF 5% 50V	
C401	1-130-481-00	MYLAR 0.0068uF 5% 50V	

Ref. No.	Part No.	Description	Remark
C402	1-130-474-00	MYLAR 0.0018uF 5% 50V	
C403	1-136-159-00	FILM 0.033uF 5% 50V	
C404	1-130-479-00	MYLAR 0.0047uF 5% 50V	
C700	1-162-284-31	CERAMIC 150PF 10% 50V	
C701	1-162-284-31	CERAMIC 150PF 10% 50V	
C702	1-164-097-11	CERAMIC 0.022uF 50V	
C703	1-161-494-00	CERAMIC 0.022uF 25V	
C704	1-130-471-00	MYLAR 0.001uF 5% 50V	
C706	1-136-157-00	FILM 0.022uF 5% 50V	
C707	1-124-473-11	ELECT 1000uF 20% 10V	
C708	1-164-097-11	CERAMIC 0.022uF 50V	
C709	1-124-126-00	ELECT 47uF 20% 10V	
C711	1-162-306-11	CERAMIC 0.01uF 20% 16V	
C712	1-162-306-11	CERAMIC 0.01uF 20% 16V	
C713	1-162-306-11	CERAMIC 0.01uF 20% 16V	
C714	1-136-164-00	FILM 0.082uF 5% 50V	
C715	1-136-164-00	FILM 0.082uF 5% 50V (F417R:G)	
C716	1-124-768-11	ELECT 4.7uF 20% 50V	
C717	1-161-494-00	CERAMIC 0.022uF 25V	
C718	1-124-477-11	ELECT 47uF 20% 16V	
C750	1-124-907-11	ELECT 10uF 20% 50V	
C751	1-124-907-11	ELECT 10uF 20% 50V	
C752	1-136-159-00	FILM 0.033uF 5% 50V	
C753	1-136-159-00	FILM 0.033uF 5% 50V	
C754	1-136-159-00	FILM 0.033uF 5% 50V	
C756	1-161-494-00	CERAMIC 0.022uF 25V	
C914	1-136-153-00	FILM 0.01uF 5% 50V	
C915	1-124-480-11	ELECT 470uF 20% 25V	
C916	1-124-907-11	ELECT 10uF 20% 50V	
C917	1-124-927-11	ELECT 4.7uF 20% 50V (F417R:E)	

< CONNECTOR >

CN1	* 1-564-321-00	PIN, CONNECTOR 2P	
CN2	1-564-321-00	PIN, CONNECTOR 2P (F317R/F417R:AEP, G)	
CN2	1-564-104-00	PIN, CONNECTOR 3P (F417R:E)	
CN3	* 1-564-321-21	PIN, CONNECTOR 2P	
CN4	* 1-564-321-00	PIN, CONNECTOR 2P (F417R:E)	
CNJ1	 1-540-042-11	OUTLET, AC (NONPOLAR) (3P) (AC OUTLET) (F417R:E)	
CNJ700	* 1-561-651-00	SOCKET, CONNECTOR 7P	
CNJ702	* 1-568-648-11	SOCKET, CONNECTOR 15P	
CNJ703	1-568-646-11	SOCKET, CONNECTOR (PC BOARD) 15P	
CNJ710	1-566-213-11	PIN, CONNECTOR 4P (CONTROL S OUT)	
CNP700	* 1-565-366-11	PIN, CONNECTOR (PC BOARD) 7P	
CNP701	* 1-565-367-11	PIN, CONNECTOR (PC BOARD) 5P	
CNP704	* 1-564-505-11	PLUG, CONNECTOR 2P	
CNP710	* 1-564-339-00	PIN, CONNECTOR 5P	
CNP750	* 1-564-505-11	PLUG, CONNECTOR 2P	

Note: The components identified by mark  or dotted line with mark  are critical for safety. Replace only with part number specified.

CONTROL

FUNC

Ref. No.	Part No.	Description	Remark
		< DIODE >	
D700	8-719-914-12	DIODE HZ4BLL	
D701	8-719-912-20	DIODE 1SS120	
D702	8-719-200-77	DIODE 10E2N	
D705	8-719-912-20	DIODE 1SS120	
D706	8-719-912-20	DIODE 1SS120	
D707	8-719-912-20	DIODE 1SS120	
D708	8-719-912-20	DIODE 1SS120	
D709	8-719-912-20	DIODE 1SS120	
D710	8-719-912-20	DIODE 1SS120	
D711	8-719-912-20	DIODE 1SS120	
D712	8-719-912-20	DIODE 1SS120	
D713	8-719-912-20	DIODE 1SS120	
D714	8-719-912-20	DIODE 1SS120	
D715	8-719-302-07	DIODE SEL1810A-C-D (MONITOR)	
D716	8-719-312-31	DIODE SEL1515C-C-D (TAPE 1)	
D717	8-719-312-31	DIODE SEL1515C-C-D (VIDEO/AUX)	
D718	8-719-312-31	DIODE SEL1515C-C-D (CD)	
D719	8-719-312-31	DIODE SEL1515C-C-D (TUNER)	
D720	8-719-312-31	DIODE SEL1515C-C-D (PHONO)	
D721	8-719-933-33	DIODE HZS6A1L	
D722	8-719-301-52	DIODE SEL2810A-C (DIRECT)	
D723	8-719-301-52	DIODE SEL2810A-C (DIRECT)	
D725	8-719-912-20	DIODE 1SS120	
D750	8-719-912-20	DIODE 1SS120	
D751	8-719-912-20	DIODE 1SS120 (F417R)	
D752	8-719-912-20	DIODE 1SS120 (F417R)	
D753	8-719-912-20	DIODE 1SS120 (F417R)	
D754	8-719-912-20	DIODE 1SS120 (F417R)	
D755	8-719-912-20	DIODE 1SS120 (F417R)	
D756	8-719-912-20	DIODE 1SS120	
D757	8-719-200-77	DIODE 10E2N	
D758	8-719-912-20	DIODE 1SS120	
D909	8-719-511-40	DIODE S1V840	
D913	8-719-912-20	DIODE 1SS120	
D914	8-719-912-20	DIODE 1SS120	
		< FUSE >	
F1	△ 1-532-203-00	FUSE, TIME-LAG (T2.0A) (F417R:E)	
F1	△ 1-532-259-00	FUSE, TIME-LAG (T1.6A) (F317R)	
F1	△ 1-532-286-00	FUSE, TIME-LAG (T2.5A) (F417R:AEP, G)	
F2	△ 1-532-203-00	FUSE, TIME-LAG (T2.0A) (F417R:E)	
F2	△ 1-532-286-00	FUSE, TIME-LAG (T2.5A) (F317R/F417R:AEP, G)	

Ref. No.	Part No.	Description	Remark
		< IC >	
IC101	8-759-636-73	IC M5218AL-22	
IC102	8-759-801-01	IC LC4966 (F317R)	
IC700	8-759-632-61	IC M50761-258P	
IC701	8-759-802-52	IC LC7818	
IC900	8-759-231-53	IC TA7805S	
IC950	8-759-604-33	IC M5F7812L (F417R:E)	
		< JACK >	
J100	1-565-320-11	JACK, PIN 6P (PHONO/TUNER/CD IN)	
J101	1-565-320-11	JACK, PIN 6P (VIDEO, AUX/TAPE1 IN, RECOUT)	
J102	1-568-529-21	JACK, PIN 4P (TAPE2/DAT IN, RECOUT)	
		< TRANSISTOR >	
Q101	8-729-900-63	TRANSISTOR DTA124ES (F317R)	
Q102	8-729-900-36	TRANSISTOR DTC124ES (F317R)	
Q700	8-729-620-05	TRANSISTOR 2SC2603-EF	
Q701	8-729-620-05	TRANSISTOR 2SC2603-EF	
Q702	8-729-620-05	TRANSISTOR 2SC2603-EF	
Q703	8-729-620-05	TRANSISTOR 2SC2603-EF	
Q704	8-729-900-63	TRANSISTOR DTA124ES	
Q705	8-729-620-05	TRANSISTOR 2SC2603-EF	
Q706	8-729-620-05	TRANSISTOR 2SC2603-EF	
Q707	8-729-900-63	TRANSISTOR DTA124ES	
Q708	8-729-900-63	TRANSISTOR DTA124ES	
Q709	8-729-900-63	TRANSISTOR DTA124ES	
Q710	8-729-900-63	TRANSISTOR DTA124ES	
Q711	8-729-900-63	TRANSISTOR DTA124ES (F417R)	
Q712	8-729-900-63	TRANSISTOR DTA124ES (F417R)	
Q713	8-729-900-63	TRANSISTOR DTA124ES	
Q714	8-729-900-36	TRANSISTOR DTC124ES	
Q715	8-729-111-29	TRANSISTOR 2SD1616A-K	
Q716	8-729-118-01	TRANSISTOR 2SB1116-K	
Q717	8-729-119-76	TRANSISTOR 2SA1175-HFE	
Q750	8-729-900-63	TRANSISTOR DTA124ES	
Q751	8-729-900-63	TRANSISTOR DTA124ES	
		< RESISTOR >	
R101	1-249-409-11	CARBON 220 5% 1/4W (F417R:G)	
R102	1-249-417-11	CARBON 1K 5% 1/4W	
R103	1-249-409-11	CARBON 220 5% 1/4W (F417R:G)	
R104	1-249-417-11	CARBON 1K 5% 1/4W	
R105	1-249-409-11	CARBON 220 5% 1/4W (F417R:G)	
R106	1-249-409-11	CARBON 220 5% 1/4W (F417R:G)	
R107	1-249-409-11	CARBON 220 5% 1/4W (F417R:G)	
R108	1-249-414-11	CARBON 560 5% 1/4W (F317R/F417R:AEP, E)	

Note: The components identified by mark △ or dotted line with mark △ are critical for safety. Replace only with part number specified.

CONTROL

FUNC

Ref. No.	Part No.	Description	Remark			Ref. No.	Part No.	Description	Remark		
R108	1-249-418-11	CARBON	1. 2K	5%	1/4W (F417R:G)	R408	1-249-437-11	CARBON	47K	5%	1/4W
R109	1-249-441-11	CARBON	100K	5%	1/4W	R700	1-249-423-11	CARBON	3. 3K	5%	1/4W
R110	1-249-418-11	CARBON	1. 2K	5%	1/4W (F417R:G)	R701	1-247-903-00	CARBON	1M	5%	1/4W
R111	1-249-441-11	CARBON	100K	5%	1/4W	R702	1-249-417-11	CARBON	1K	5%	1/4W
R112	1-249-416-11	CARBON	820	5%	1/4W	R703	1-249-441-11	CARBON	100K	5%	1/4W
R113	1-247-897-11	CARBON	560K	5%	1/4W	R704	1-249-433-11	CARBON	22K	5%	1/4W
R114	1-249-437-11	CARBON	47K	5%	1/4W	R705	1-249-429-11	CARBON	10K	5%	1/4W
R115	1-249-441-11	CARBON	100K	5%	1/4W	R706	1-249-441-11	CARBON	100K	5%	1/4W
R116	1-249-409-11	CARBON	220	5%	1/4W	R707	1-249-433-11	CARBON	22K	5%	1/4W
R117	1-249-405-11	CARBON	100	5%	1/4W	R708	1-249-417-11	CARBON	1K	5%	1/4W
R118	1-249-405-11	CARBON	100	5%	1/4W	R709	1-249-393-11	CARBON	10	5%	1/4W
R119	1-249-433-11	CARBON	22K	5%	1/4W (F317R)	R710	1-249-429-11	CARBON	10K	5%	1/4W
R120	1-249-433-11	CARBON	22K	5%	1/4W (F317R)	R711	1-249-417-11	CARBON	1K	5%	1/4W
R150	1-249-441-11	CARBON	100K	5%	1/4W (F317R)	R712	1-249-429-11	CARBON	10K	5%	1/4W
R201	1-249-409-11	CARBON	220	5%	1/4W (F417R:G)	R713	1-249-429-11	CARBON	10K	5%	1/4W
R202	1-249-417-11	CARBON	1K	5%	1/4W	R714	1-249-433-11	CARBON	22K	5%	1/4W
R203	1-249-409-11	CARBON	220	5%	1/4W (F417R:G)	R715	1-249-433-11	CARBON	22K	5%	1/4W
R204	1-249-417-11	CARBON	1K	5%	1/4W	R716	1-249-433-11	CARBON	22K	5%	1/4W
R205	1-249-409-11	CARBON	220	5%	1/4W (F417R:G)	R717	1-249-433-11	CARBON	22K	5%	1/4W
R206	1-249-409-11	CARBON	220	5%	1/4W (F417R:G)	R718	1-249-433-11	CARBON	22K	5%	1/4W
R207	1-249-409-11	CARBON	220	5%	1/4W (F417R:G)	R719	1-249-433-11	CARBON	22K	5%	1/4W
R208	1-249-414-11	CARBON	560	5%	1/4W (F317R/F417R:AEP, E)	R720	1-249-433-11	CARBON	22K	5%	1/4W
R208	1-249-418-11	CARBON	1. 2K	5%	1/4W (F417R:G)	R721	1-249-433-11	CARBON	22K	5%	1/4W
R209	1-249-441-11	CARBON	100K	5%	1/4W	R722	1-249-414-11	CARBON	560	5%	1/4W
R210	1-249-418-11	CARBON	1. 2K	5%	1/4W (F417R:G)	R723	1-249-411-11	CARBON	330	5%	1/4W
R211	1-249-441-11	CARBON	100K	5%	1/4W	R724	1-249-411-11	CARBON	330	5%	1/4W
R212	1-249-416-11	CARBON	820	5%	1/4W	R725	1-249-411-11	CARBON	330	5%	1/4W
R213	1-247-897-11	CARBON	560K	5%	1/4W	R726	1-249-411-11	CARBON	330	5%	1/4W
R214	1-249-437-11	CARBON	47K	5%	1/4W	R727	1-249-411-11	CARBON	330	5%	1/4W
R215	1-249-441-11	CARBON	100K	5%	1/4W	R728	1-249-429-11	CARBON	10K	5%	1/4W
R216	1-249-409-11	CARBON	220	5%	1/4W	R729	1-249-429-11	CARBON	10K	5%	1/4W
R217	1-249-405-11	CARBON	100	5%	1/4W	R731	1-247-901-11	CARBON	820K	5%	1/4W
R218	1-249-405-11	CARBON	100	5%	1/4W	R732	1-249-433-11	CARBON	22K	5%	1/4W
R301	1-247-903-00	CARBON	1M	5%	1/4W	R733	1-249-433-11	CARBON	22K	5%	1/4W
R302	1-249-421-11	CARBON	2. 2K	5%	1/4W	R734	1-249-441-11	CARBON	100K	5%	1/4W
R303	1-249-426-11	CARBON	5. 6K	5%	1/4W	R735	1-249-413-11	CARBON	470	5%	1/4W
R304	1-247-903-00	CARBON	1M	5%	1/4W	R736	1-249-416-11	CARBON	820	5%	1/4W
R305	1-247-852-11	CARBON	7. 5K	5%	1/4W	R737	1-249-419-11	CARBON	1. 5K	5%	1/4W
R306	1-247-870-11	CARBON	43K	5%	1/4W	R739	1-249-423-11	CARBON	3. 3K	5%	1/4W
R307	1-249-436-11	CARBON	39K	5%	1/4W	R740	1-249-441-11	CARBON	100K	5%	1/4W
R308	1-249-437-11	CARBON	47K	5%	1/4W	R742	1-249-423-11	CARBON	3. 3K	5%	1/4W
R401	1-247-903-00	CARBON	1M	5%	1/4W	R743	1-249-410-11	CARBON	270	5%	1/4W
R402	1-249-421-11	CARBON	2. 2K	5%	1/4W	R745	△ 1-249-393-11	CARBON	10	5%	1/4W F
R403	1-249-426-11	CARBON	5. 6K	5%	1/4W	R746	△ 1-249-393-11	CARBON	10	5%	1/4W F
R404	1-247-903-00	CARBON	1M	5%	1/4W	R747	1-249-433-11	CARBON	22K	5%	1/4W (F417R)
R405	1-247-852-11	CARBON	7. 5K	5%	1/4W	R750	1-249-433-11	CARBON	22K	5%	1/4W
R406	1-247-870-11	CARBON	43K	5%	1/4W	R906	1-247-699-11	CARBON	82	5%	1/4W
R407	1-249-436-11	CARBON	39K	5%	1/4W						(F317R/F417R:AEP, G)

Note: The components identified by mark △ or dotted line with mark △ are critical for safety. Replace only with part number specified.

CONTROL**FUNC**

Ref. No.	Part No.	Description	Remark
< VARIABLE RESISTOR >			
RV300	1-238-638-11	RES. VAR. CARBON 150K/150K (BALANCE)	
RV301	1-238-639-11	RES. VAR 250K/250K (TREBLE)	
RV302	1-238-640-11	RES. VAR. CARBON 520K/520K (BASS)	
RV303	1-238-628-21	RES. VAR. CARBON (MOTOR) 120KX2 (VOLUME)	
< RELAY >			
RY1	1-515-516-00	RELAY (F317R/F417R:AEP, G)	
RY1	1-515-617-11	RELAY (F417R:E)	
< SWITCH >			
SW100	1-571-115-11	SWITCH, SLIDE (RECOUT SELECTOR) (F417R)	
SW301	1-571-828-11	SWITCH, PUSH (1 KEY) (SOURCE DIRECT)	
SW700	1-554-303-21	SWITCH, TACTILE (PHONO)	
SW701	1-554-303-21	SWITCH, TACTILE (TUNER)	
SW702	1-554-303-21	SWITCH, TACTILE (CD)	
SW703	1-554-303-21	SWITCH, TACTILE (VIDEO/AUX)	
SW704	1-554-303-21	SWITCH, TACTILE (TAPE1)	
SW705	1-554-303-21	SWITCH, TACTILE (MONITOR TAPE2/DAT)	
< TRANSFORMER >			
T2	Δ 1-449-297-11	TRANSFORMER, POWER (F317R/F417R:AEP, G)	
T2	Δ 1-449-299-11	TRANSFORMER, POWER (F417R:E)	
< CERAMIC >			
X700	1-577-077-11	OSCILLATOR, CERAMIC (400kHz)	

MISCELLANEOUS			

9	1-571-972-11	SWITCH, ROTARY SLIDE (SW100)	
9	1-571-972-21	SWITCH, ROTARY SLIDE (SW100) (F417R:AE2)	
56	* 1-533-213-31	HOLDER, FUSE (F317R/F417R:AEP, G, E)	
56	* 1-533-213-31	HOLDER, FUSE (F417R:AE1)	
74	Δ 1-569-007-11	ADAPTER, CONVERSION 2P (F417R:E)	
75	* 1-535-771-11	TERMINAL (F317R/F417R:AEP, G)	
CNJ1	Δ 1-526-794-11	OUTLET, AC (AC OUTLET) (F317R/F417R:AEP, G)	
CP1	Δ 1-574-805-11	CORD, POWER (F317R/F417R:AEP, G)	
CP1	Δ 1-574-902-11	CORD, POWER (F417R:E)	
S1	Δ 1-571-515-11	SWITCH, POWER VOLTAGE SELECTION (F417R:E)	
T1	Δ 1-449-747-11	TRANSFORMER, POWER (F417R:E)	
T1	Δ 1-450-551-11	TRANSFORMER, POWER (F317R)	
T1	Δ 1-450-552-11	TRANSFORMER, POWER (F417R:AE1)	
T1	Δ 1-450-553-11	TRANSFORMER, POWER (F417R:AE2)	
T1	Δ 1-450-554-11	TRANSFORMER, POWER (F417R:G)	

Ref. No.	Part No.	Description	Remark
ACCESSORY & PACKING MATERIAL			

	1-465-199-11	REMOTE COMMANDER (RM-S310)	
*	3-704-343-01	SHEET (STANDARD), PROTECTION (F317R/F417R:AE1, G, E)	
	3-753-407-11	MANUAL, INSTRUCTION (F317R/F417R:AEP, E) (ENGLISH, FRENCH, SPANISH, PORTUGUESE)	
	3-753-407-41	MANUAL, INSTRUCTION (F317R/F417R:AEP, G) (GERMAN, DUTCH, SWEDISH, ITALIAN)	
*	4-944-047-01	INDIVIDUAL CARTON (F317R)	
*	4-944-048-01	INDIVIDUAL CARTON (F417R)	
*	4-945-810-01	CUSHION (LEFT)	
*	4-945-811-01	CUSHION (RIGHT)	

HARDWARE LIST

# 1	7-621-849-00	SCREW, TAPPING
# 2	7-682-546-04	SCREW +B 3X5 (F317R)
# 3	7-682-547-09	SCREW +BVTT 3X6 (S)
# 4	7-682-548-04	SCREW +BVTT 3X8 (S)
# 5	7-682-548-09	SCREW +B 3X8 (F417R)
# 6	7-682-560-04	SCREW +BVTT 4X6 (S)
# 7	7-682-950-01	SCREW +PSW 3X12
# 8	7-685-534-19	SCREW +BTP 2.6X8 TYPE2 N-S
# 9	7-685-646-79	SCREW +BVTP 3X8 TYPE2 N-S

Note: The components identified by mark Δ or dotted line with mark Δ are critical for safety. Replace only with part number specified.

TA-F317R/F417R

SONY®
SERVICE MANUAL

AEP Model
TA-F317R/F417R

E Model
TA-F417R

SUPPLEMENT-1

File this Supplement with the Service Manual.

BLOCK DIAGRAM

1. BLOCK DIAGRAM

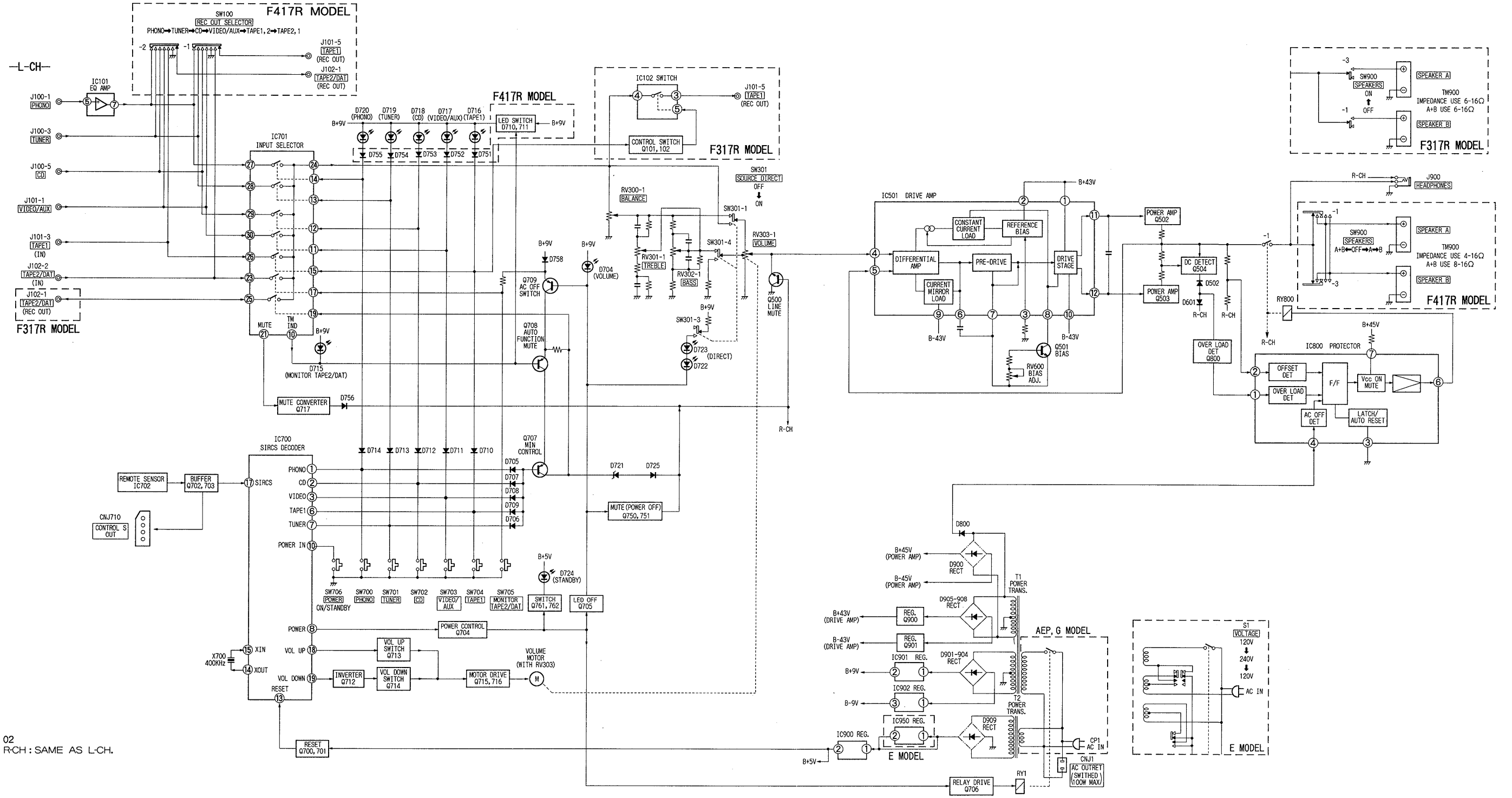

02
R-CH: SAME AS L-CH.