

TA-F319R

SERVICE MANUAL

AEP Model
UK Model
E Model



SPECIFICATIONS

Amplifier

Continuous RMS power output (both channels driven simultaneously)

Model for Germany

DIN, 1 kHz	4 ohms	50 W + 50 W
	8 ohms	40 W + 40 W
20 Hz - 20 kHz	4 ohms	—
	8 ohms	30 W + 30 W

Model for Scandinavian countries, Switzerland, Spain and Portugal

DIN, 1 kHz	6 ohms	—
	8 ohms	50 W + 50 W
20 Hz - 20 kHz	6 ohms	—
	8 ohms	40 W + 40 W

Model for other countries

DIN, 1 kHz	4 ohms	—
	8 ohms	50 W + 50 W
20 Hz - 20 kHz	4 ohms	—
	8 ohms	40 W + 40 W

Input

Input jack	Jack type	Sensitivity	Impedance
PHONO	Phono	2.0 mV	50 kilohms
TUNER, CD, AUX, DAT/TAPE 1, TAPE 2	Phono	150 mV	50 kilohms

S/N

PHONO (MM)	—
TUNER, CD, AUX, DAT/TAPE 1, TAPE 2	100 dB

Output

Output jack	Jack type	Voltage/impedance
REC OUT	Phono jack	Voltage 150 mV Impedance 1 kohm
HEADPHONES	Stereo phono jack	Accepts low and high impedance headphones

Tone controls

	Response	Turnover frequency
BASS	±7 dB (100 Hz)	300 Hz
TREBLE	±6 dB (10 kHz)	5 kHz

INTEGRATED STEREO AMPLIFIER
SONY®

Harmonic distortion Less than 0.03% at 10 W output
 Intermodulation (IM) distortion (60 Hz : 7 kHz = 4:1)
 Less than 0.03% at 10 W output
 Frequency response
 PHONO: RIAA equalization curve
 ±0.5 dB
 TUNER, CD, AUX, DAT/TAPE 1,
 TAPE 2: 7 Hz – 100 kHz ± 0.3 dB
 Residual noise Less than 170 μ V (network A)
 Damping factor 50 (8 ohms, 1 kHz)

General System

Preamplifier: Low-noise, equalizer amplifier
 Power amplifier: Pure-complementary SEPP OCL power amplifier with all stages directly coupled

Power requirements

UK model : 240 V AC, 50/60 Hz
 AEP, Germany model :
 220 V – 230 V AC, 50/60 Hz
 E model : 120 V, 220 V or 240 V AC adjustable, 50/60 Hz

Power consumption

130 W

Dimensions

Approx. 430 x 135 x 315 mm (w/h/d)
 (17 x 5 $\frac{3}{8}$ x 12 $\frac{1}{2}$ inches)

Weight

Approx. 6.3 kg (13 lb 14 oz)

Supplied accessories

Remote commander RM-S311 (1)
 Sony SUM-3 (NS) batteries (2)

The above values are measured at 230 V AC. (Models for European countries)

Design and specifications are subject to change without notice.

Note

This appliance conforms with EEC Directive 87/308/EEC regarding interference suppression.

MODEL IDENTIFICATION

- Specification Label Printed on Back Panel -

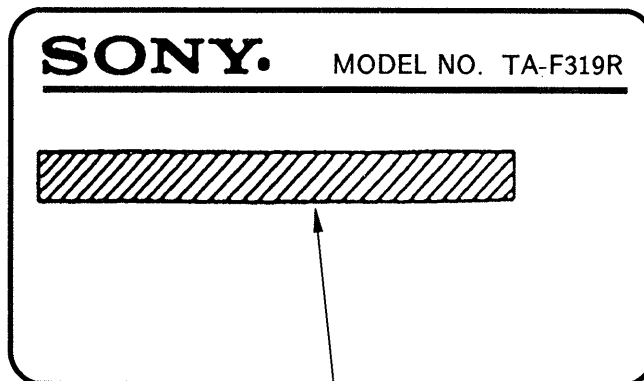

AEP, Germany Model : AC : 220 - 230V ~ 50/60Hz

UK Model : AC : 240V ~ 50/60Hz

E Model : AC : 120/220/240V ~ 50/60Hz

Note :

There are two type of AEP models which are depend on countries.

AEP2 model : Model for Scandinavian countries, Switzerland, Spain and Portugal

AEP1 model : Model for other European countries

TABLE OF CONTENTS

<i>Section</i>	<i>Title</i>	<i>Page</i>
Specifications		1
Model Identification		2
1. GENERAL		3
2. ELECTRICAL ADJUSTMENTS		4
3. DIAGRAMS		
3-1. Block Diagram		5
3-2. Circuit Boards Location		7
3-3. Printed Wiring Boards		10
3-4. Schematic Diagram		15
3-5. IC Block Diagram		19
4. EXPLODED VIEWS		
4-1. Front Panel Section		20
4-2. Chassis Section		21
5. ELECTRICAL PARTS LIST		22

SAFETY-RELATED COMPONENT WARNING!!

COMPONENTS IDENTIFIED BY MARK \triangle OR DOTTED LINE WITH MARK \triangle ON THE SCHEMATIC DIAGRAMS AND IN THE PARTS LIST ARE CRITICAL TO SAFE OPERATION. REPLACE THESE COMPONENTS WITH SONY PARTS WHOSE PART NUMBERS APPEAR AS SHOWN IN THIS MANUAL OR IN SUPPLEMENTS PUBLISHED BY SONY.

**SECTION 1
GENERAL**

This section is extracted from instruction manual.

Identifying the Parts and Controls

This section describes about each name of this amplifier and remote commander.

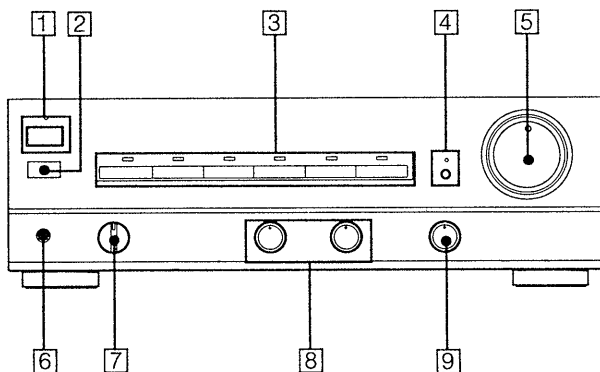

Front Panel

- 1 POWER switch and STANDBY indicator
- 2 Remote control sensor
- 3 Function selectors and indicators (MONITOR indicator: Only for TA-F319R)
- 4 SOURCE DIRECT button and indicator
- 5 VOLUME control and indicator
Adjusts the sound level.
Immediately after turning on the POWER switch, the VOLUME indicator blinks when the built-in muting circuit activates and the unit detects shorting of circuit of the speaker outputs or in case of short-circuit of the inputs of DC components. In such case, turn off the unit and check the connected components and speaker system. (For TA-F319R, the VOLUME indicator does not blink.)
- 6 HEADPHONES jack
- 7 SPEAKERS selector
- 8 TONE (BASS/TREBLE) controls
- 9 BALANCE control

Remote Commaner

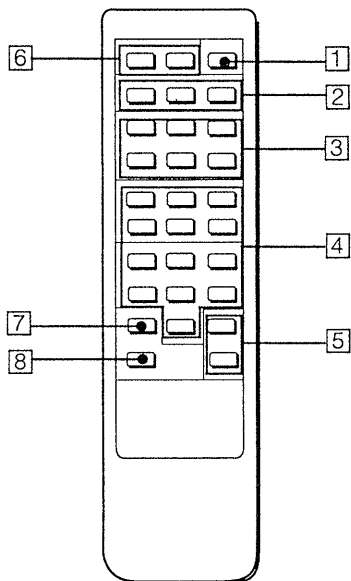

RM-S311

- 1 POWER switch
- 2 TUNER operation buttons
TUNER: Select the TUNER mode.
PRESET +/- buttons: Select the preset station.
- 3 CD operation buttons
◀▶▶▶: Automatic music sensor.
D. (Disc) SKIP: Disc skip (for CD player equipped with a multi-disc changer)
▶: The amplifier enters the CD mode and the CD player starts playback automatically.
■: Stop.
⏸: Pause.
- 4 TAPE 2 DECK A/DECK B operation buttons
◀▶▶▶: Fast winding.
■: Stop.
◀: The amplifier enters the TAPE 2 mode and the tape deck starts reverse playback automatically.
▶: The amplifier enters the TAPE 2 mode and the tape deck starts forward playback automatically.
●: Recording.
⏸: Pause. (Only for DECK B)
- 5 VOL (Volume) +/- buttons
- 6 PHONO operation buttons
START: Pressing START automatically selects the PHONO mode on the amplifier and starts playback of the turntable system.
STOP: Stops playback of the turntable system.
- 7 DAT/TAPE 1 button
Selects the DAT or TAPE 1 mode.
- 8 AUX button
Selects the AUX mode.

SECTION 2 ELECTRICAL ADJUSTMENTS

Note :

1. DC BIAS adjustments should be made within 2 to 3 minutes after the POWER switch is turned on (POWER ON).
2. After replacing the power transistors, DC BIAS adjustments should be made.

DC Bias Adjustment (with no signal input)

Procedure :

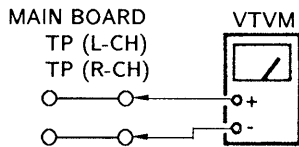

	Adjustment part	Reading on VTVM
L-CH	RV501	6.5mV
R-CH	RV601	6.5mV

【MAIN BOARD】

— COMPONENT SIDE —

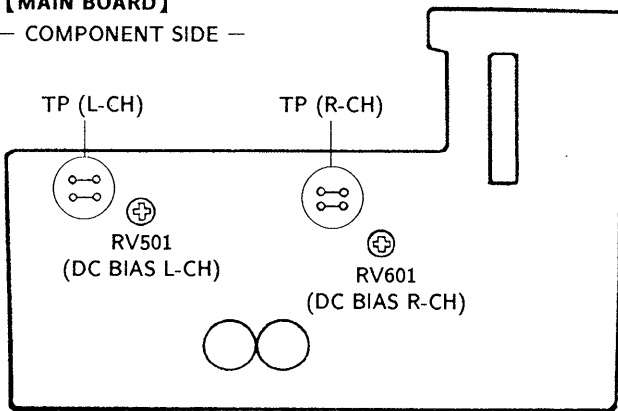

SECTION 3 DIAGRAMS

3-1. BLOCK DIAGRAM

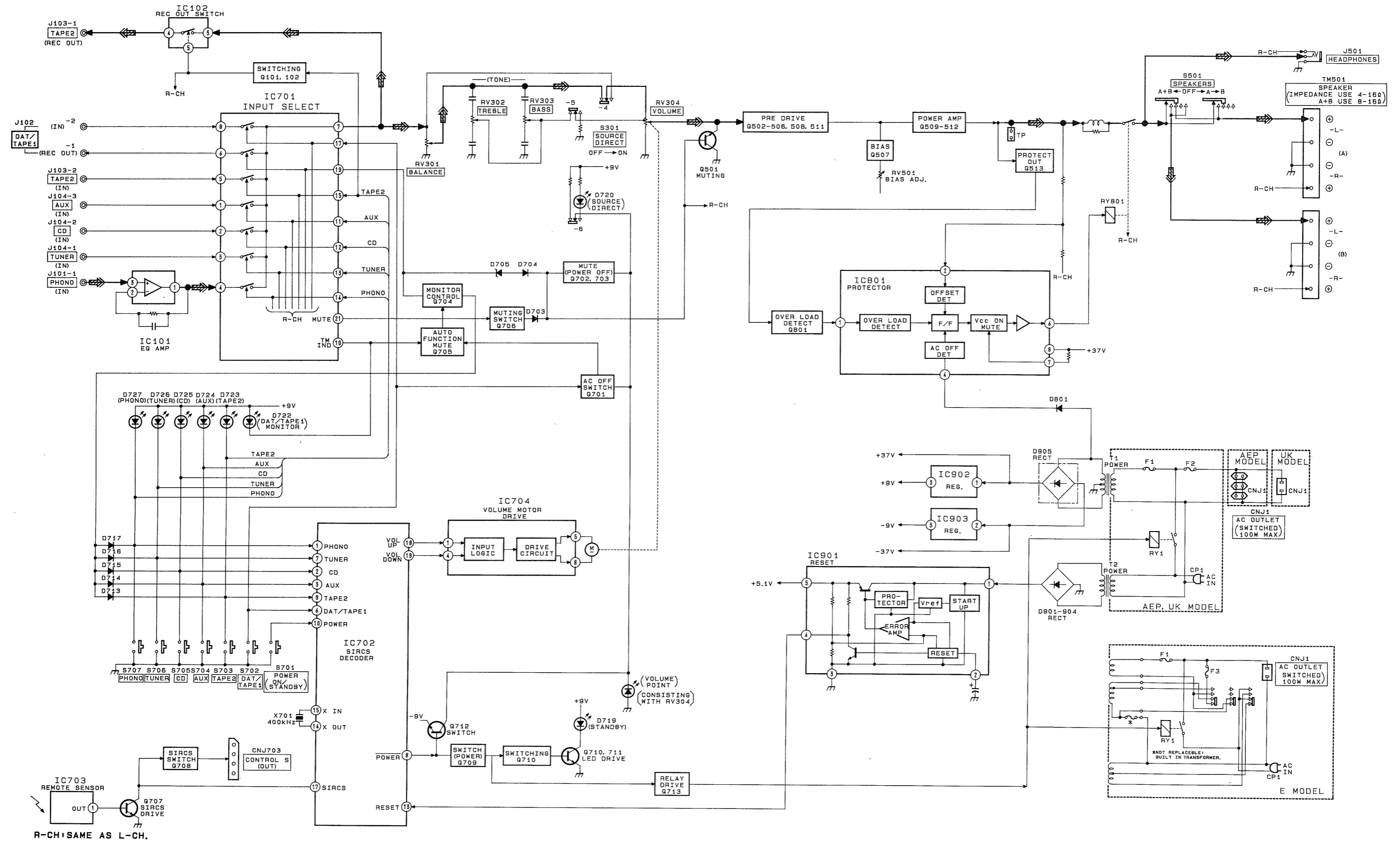

3-2. CIRCUIT BOARDS LOCATION

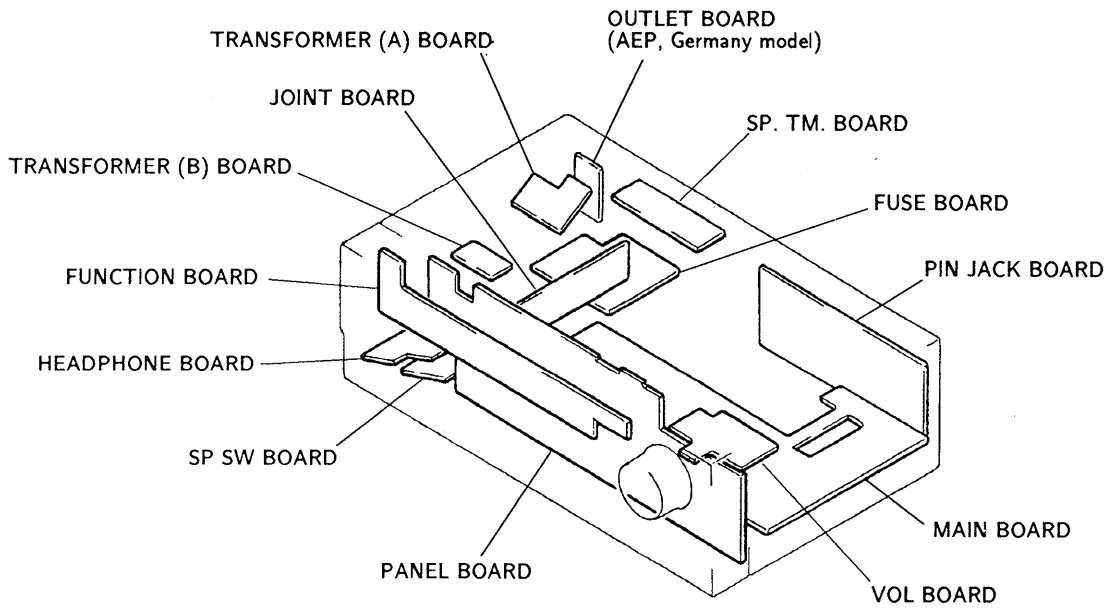

● IC702 Function Controller (M50761-291P)

Micro Processor M50761-291P is used for control the volume up/down, function select and power on/standby by SIRCS code signal input and power on/standby key code signal input.

Pin No.	Pin Name	I/O	Description						
1	PHONO	O	Function select output. (one-shot output) (L : PHONO)						
2	CD	O	Function select output. (one-shot output) (L : CD)						
3	AUX	O	Function select output. (one-shot output) (L : AUX)						
4	CN VSS	—	Ground						
5	VSS	—	Ground						
6	TAPE1	O	Function select output. (one-shot output) (L : TAPE1)						
7	TUNER	O	Function select output. (one-shot output) (L : TUNER)						
8	POWER	O	Power supply ON/OFF relay (RY1) control output. (L : POWER ON, H : POWER OFF)						
9	TAPE2	O	Function select output. (one-shot output) (L : TAPE2)						
10	POWER IN	I	POWER ON/STANDBY key switch input.						
11	MODE	I	Mode select input. This model is used "H" level only. <table border="1" style="margin-left: 20px;"> <thead> <tr> <th></th> <th>POWER ON/OFF mode</th> </tr> </thead> <tbody> <tr> <td>H</td> <td>USED</td> </tr> <tr> <td>L</td> <td>NOT USED</td> </tr> </tbody> </table>		POWER ON/OFF mode	H	USED	L	NOT USED
	POWER ON/OFF mode								
H	USED								
L	NOT USED								
12	NC	—	Ground						
13	RESET	I	Reset signal input.						
14	X OUT	O	Ceramic vibrator connection terminal. (400Hz)						
15	X IN	O	Ceramic vibrator connection terminal. (400Hz)						
16	NC	—	Ground						
17	SIRCS	I	SIRCS code signal input. (serial input)						
18	VOL UP	O	Volume motor up control output. (contineous output)						
19	VOL DOWN	O	Volume motor down control output. (contineous output)						
20	VDD	—	+5V power supply.						

• SEMICONDUCTOR LEAD LAYOUTS

GP1U52XB

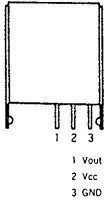

DTA124ES
DTC114ES
DTC124ES
2SC2603-EF
2SC3622A-LK
2SC4048



2SA1684-LK

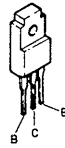

HZS6A1L
HZS6B1L

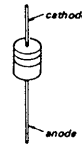

L78MR05

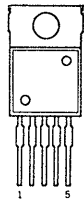

DTC114TS
2SA1175-HFE

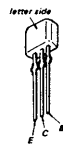

2SC1841-PAFAEA



RBV-620-01

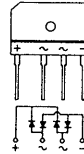

2SC1941-LK



1N4148M
10E2N

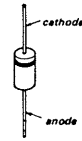

M5F7909L

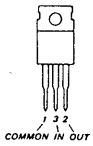

2SA979-FG



2SC4431-LK

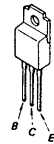

SEL3210S-CD
SEL3810A-CD

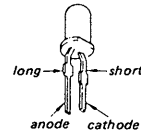

RC7809FA

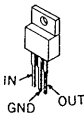

2SA988-PAFAEA
2SA1371-E

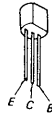

2SK246-GR



SEL3510-CD

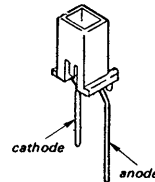

μ PC1237HA

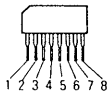

2SA1489-OPY
2SC3853-OPY
2SD2012

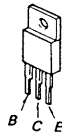

• SEMICONDUCTOR LOCATION

Ref. No.	Location	Ref. No.	Location	Ref. No.	Location
D501	H-21	D903	C-8	O605	I-16
D502	H-23	D904	C-8	O606	H-16
D503	H-23	D905	J-18	O607	F-17
D504	I-23	D906	H-20	O608	H-17
D601	I-16	D907	H-19	O609	H-16
D602	H-18	D908	D-8	O610	H-18
D603	G-18	D909	D-8	O611	F-16
D604	G-19			O612	F-18
D701	C-17			O613	G-18
D702	D-17	IC101	D-23	O614	I-17
		IC102	D-21		
D703	C-17	IC701	D-19	Q701	B-17
D704	C-17	IC702	I-27	Q702	D-17
D705	C-17	IC703	C-25	Q703	D-17
D706	E-17			Q704	E-18
D707	C-33	IC704	G-35	Q705	E-18
		IC801	J-22		
D708	C-29	IC901	E-9	Q706	E-17
D709	C-30	IC902	K-17	Q707	H-27
D710	C-31	IC903	J-17	Q708	H-27
D711	C-34			Q709	I-25
D712	C-35			Q710	I-25
D713	J-27	Q101	D-18	Q711	I-25
D714	J-27	Q102	D-18	Q712	J-25
D715	J-27	Q501	K-16	Q713	D-8
D716	J-27	Q502	H-22	Q801	J-22
D717	J-27	Q503	H-22		
D718	H-27	Q504	H-23		
D719	D-25	Q505	H-21		
D720	C-37	Q506	H-21		
D722	C-27	Q507	F-21		
D723	C-29	Q508	H-22		
D724	C-30	Q509	G-21		
D725	C-32	Q510	G-23		
D726	C-33	Q511	F-20		
D727	C-35	Q512	F-22		
D728	I-25	Q513	G-23		
D801	J-20	Q514	I-21		
D802	J-23	Q601	I-16		
D803	J-23	Q602	I-17		
D901	D-8	Q603	I-17		
D902	C-8	Q604	I-17		

3-3. PRINTED WIRING BOARDS • Refer to Page 8 for Semiconductor Lead Layouts.

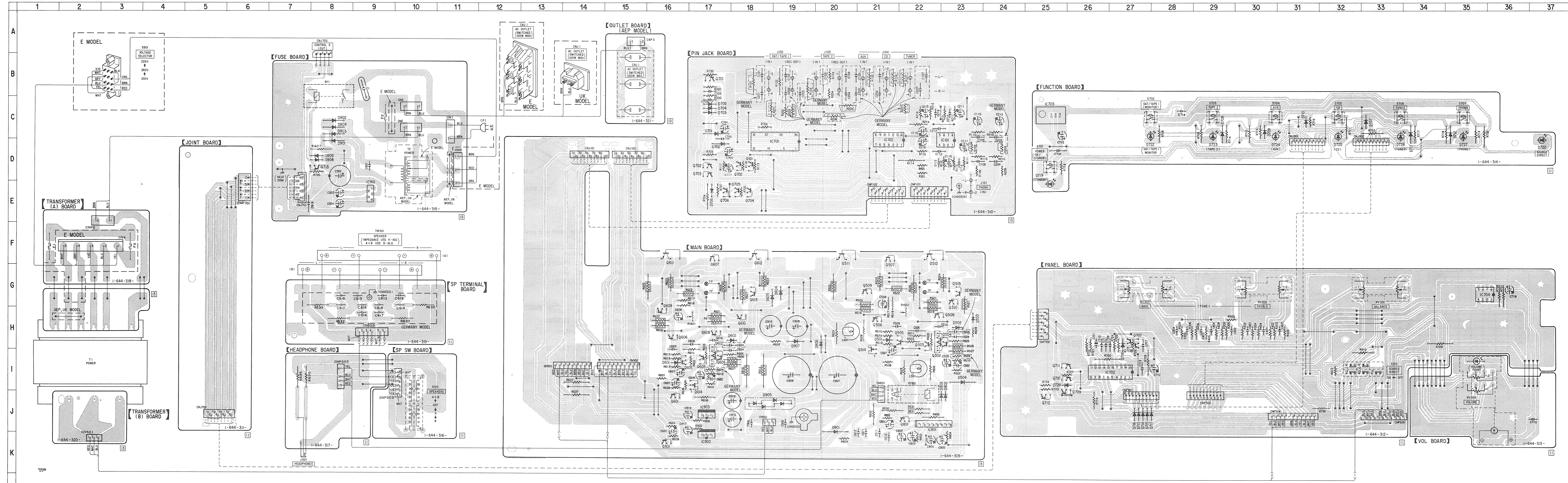

Note:
 ○ : parts extracted from the component side.
 □ : Pattern on the side which is seen.

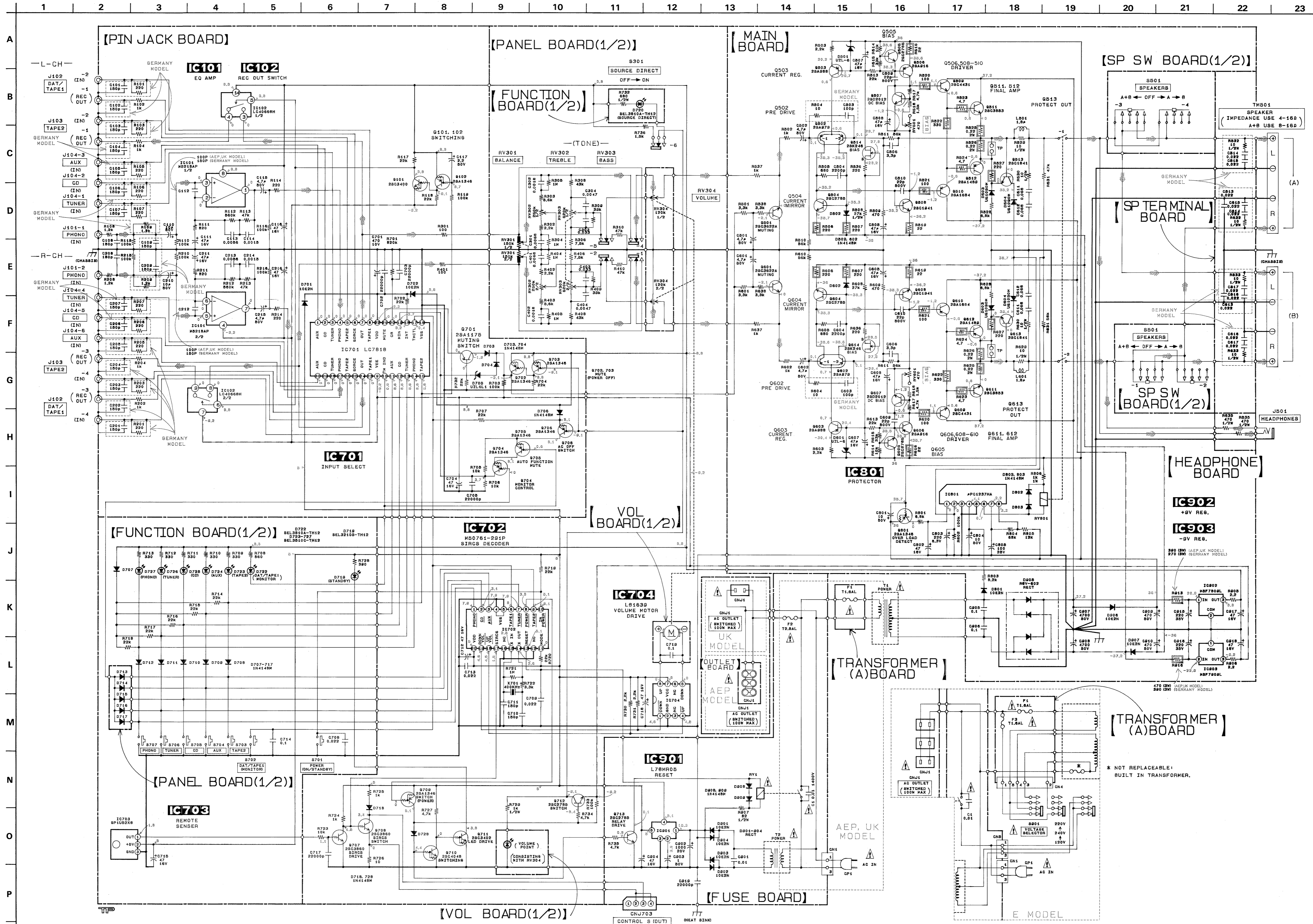

Note :

- All capacitors are in μ F unless otherwise noted. pF, μ F, μ F 50WV or less are not indicated except for electrolytics and tantalums.
- All resistors are in Ω and $\frac{1}{2}W$ or less unless otherwise specified.
- : nonflammable resistor.
- : fusible resistor.

Note : The components identified by mark or dotted line with mark are critical for safety. Replace only with part number specified.

- : B+ Line
- : B- Line
- : adjustment for repair.
- Voltage and waveforms are dc with respect to ground under no-signal conditions.
- no mark : CD
- Voltages are taken with a VOM (input impedance 10M Ω). Voltage variations may be noted due to normal production tolerances.
- Signal path.
- : PHONO

3-5. IC BLOCK DIAGRAM

IC701 LC7818

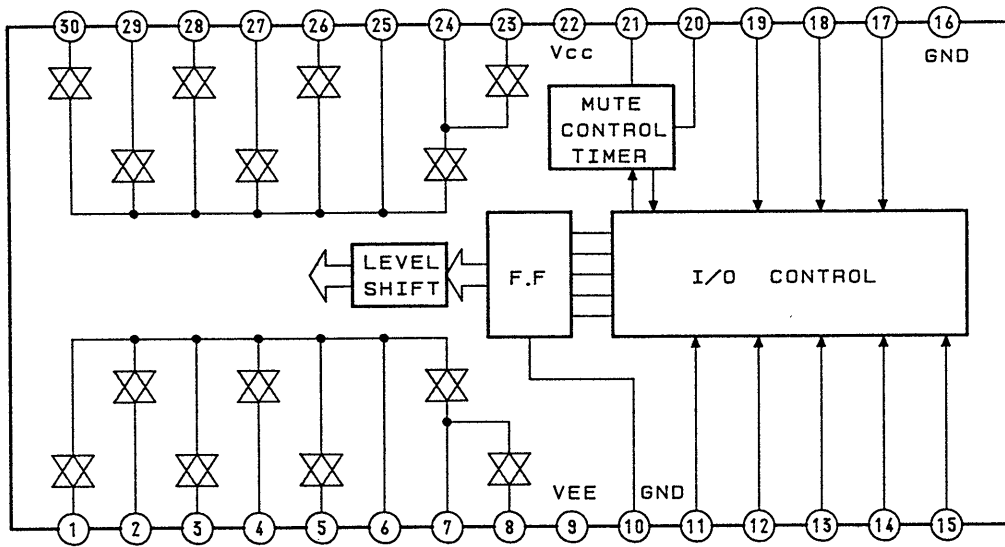

IC704 LB1639

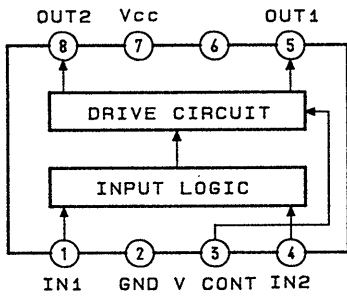

IC901 L78MR-05

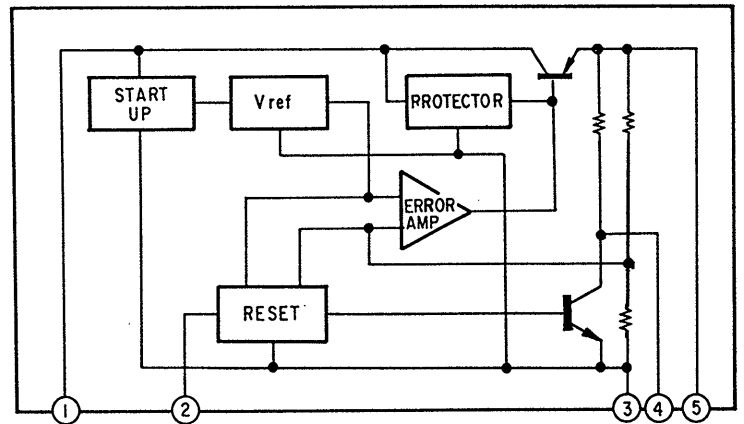

IC801 UPC1237HA

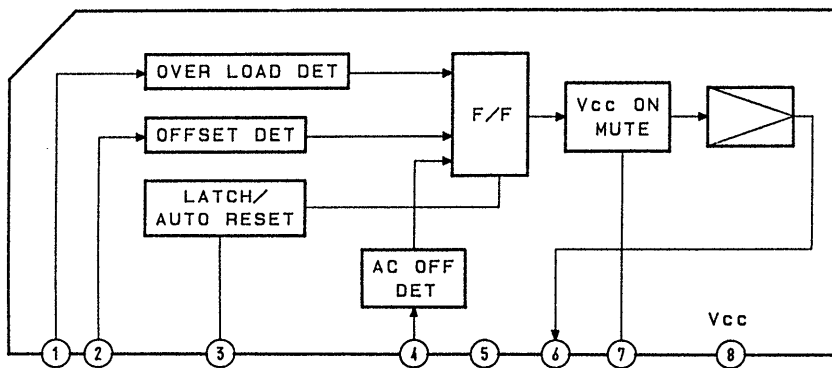

SECTION 4 EXPLODED VIEWS

NOTE:

- -XX, -X mean standardized parts, so they may have some differences from the original one.
- The construction parts of an assembled part are indicated with a collation number in the remark column.
- Color indication of Appearance Parts
Example:
KNOB, BALANCE (WHITE).... (RED)

↑ Parts color ↑ Cabinet's color

- Items marked "*" are not stocked since they are seldom required for routine service. Some delay should be anticipated when ordering these items.
- The mechanical parts with no reference number in the exploded views are not supplied.
- Hardware (# mark) list is given in the last of this parts list.

The components identified by mark or dotted line with mark are critical for safety. Replace only with part number specified.

When indicating parts by reference number, please include the board.

4-1. FRONT PANEL SECTION

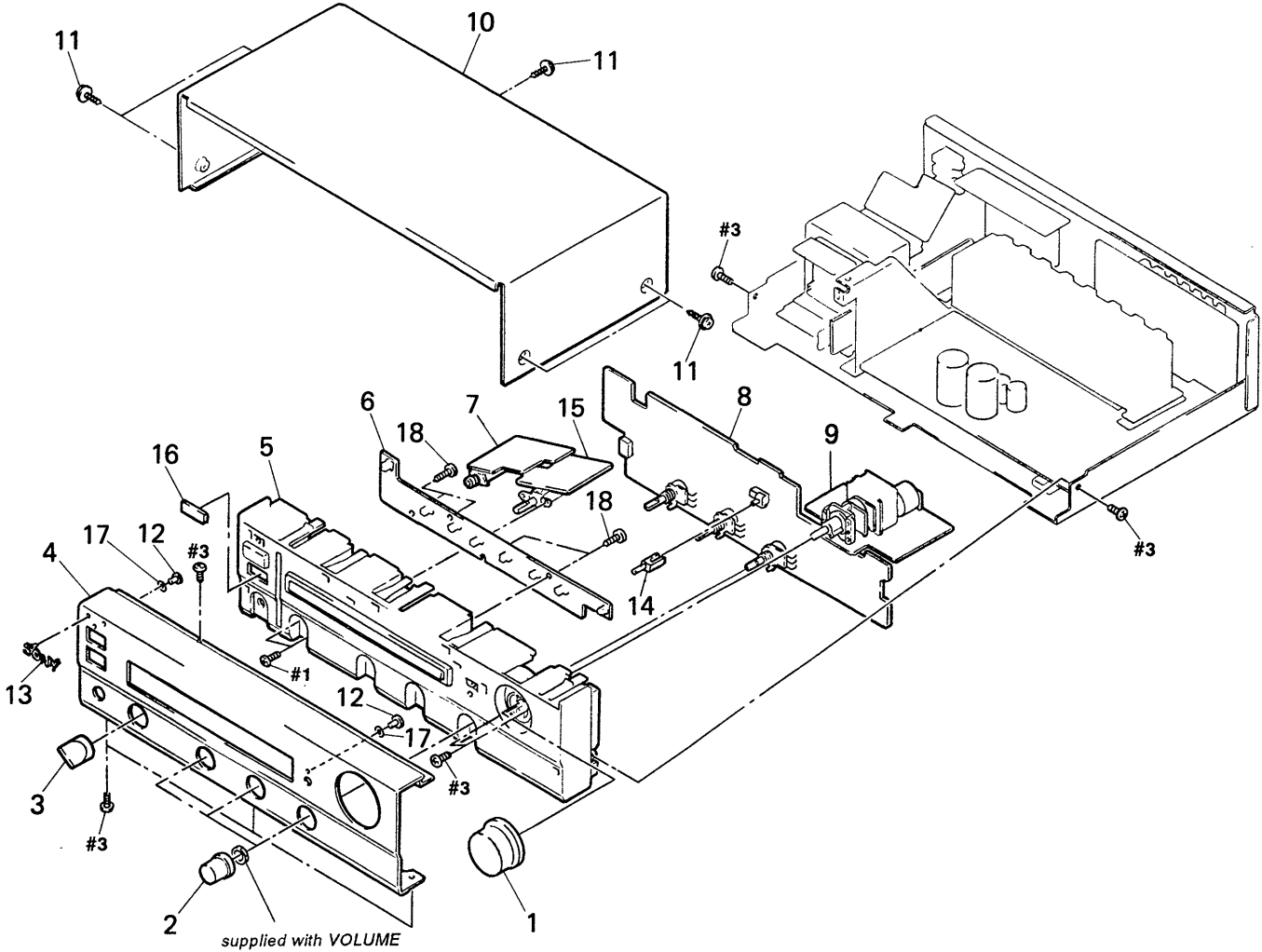

Ref. No.	Part No.	Description	Remark	Ref. No.	Part No.	Description	Remark
1	X-4942-798-1	KNOB (R53) ASSY		10	4-929-294-11	CASE	
2	4-945-173-01	KNOB (R21)		11	3-704-366-01	SCREW (CASE) (M3X8)	
3	4-916-745-01	KNOB (DIA. 21)		12	4-938-518-01	INDICATOR (C)	
4	4-952-244-01	PANEL, FRONT		13	4-908-848-01	EMBLEM, SONY	
5	X-4942-672-1	PANEL (BASE) ASSY		14	4-952-242-01	BUTTON (S/D)	
* 6	A-4347-667-A	FUNCTION BOARD, COMPLETE		* 15	1-644-316-11	SP. SW. BOARD	
* 7	1-644-317-11	HEADPHONE BOARD		16	4-931-911-01	FILTER	
* 8	A-4347-665-A	PANEL BOARD, COMPLETE		* 17	4-927-881-01	SHEET, ADHESIVE	
* 9	1-644-313-11	VOL BOARD		18	4-951-620-01	SCREW (2. 6X8), +BVTP	

4-2. CHASSIS SECTION

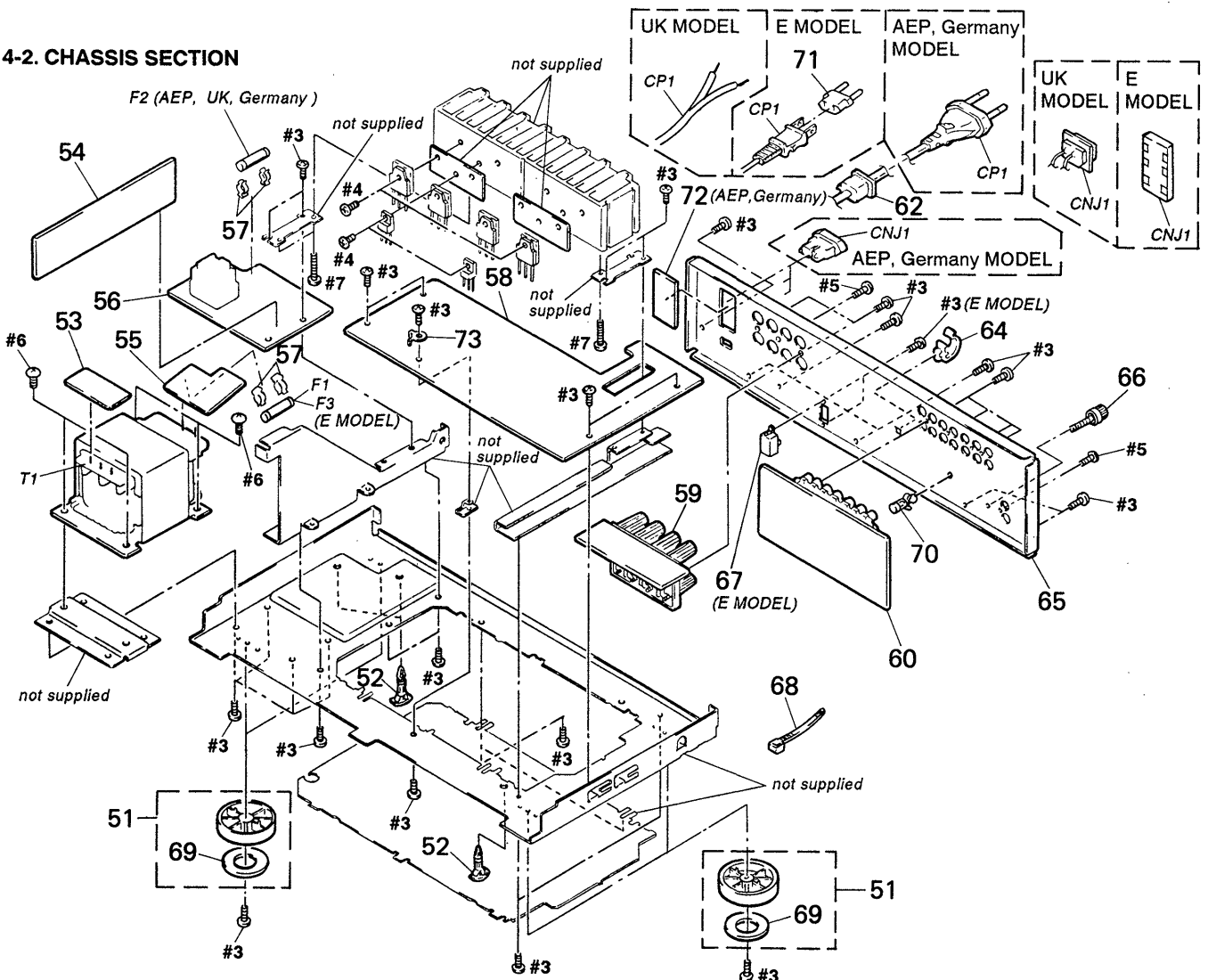

Note: The components identified by mark \triangle or dotted line with mark \triangle are critical for safety. Replace only with part number specified.

Ref. No.	Part No.	Description	Remark
	51	X-3304-938-2 FOOT ASSY	
*	52	3-704-198-31 SUPPORT, PC	
*	53	1-644-320-11 TRANSFORMER (B) BOARD	
*	54	1-644-311-11 JOINT BOARD	
*	55	1-644-318-11 TRANSFORMER (A) BOARD	
*	56	1-644-315-11 FUSE BOARD	
*	57	1-533-213-31 HOLDER, FUSE	
*	58	A-4347-660-A MAIN BOARD, COMPLETE (E, AEP, UK)	
*	58	A-4347-661-A MAIN BOARD, COMPLETE (Germany)	
*	59	1-644-319-11 SP. TM. BOARD	
*	60	A-4347-662-A PIN JACK BOARD, COMPLETE (E, AEP, UK)	
*	60	A-4347-663-A PIN JACK BOARD, COMPLETE (Germany)	
*	62	3-703-244-00 BUSHING (2104), CORD (AEP, Germany, UK)	
*	62	3-703-571-11 BUSHING (S) (4516), CORD (E)	
*	64	4-949-235-01 HOOK	
*	65	4-951-972-11 PANEL, BACK (AEP)	
*	65	4-951-972-21 PANEL, BACK (Germany)	
*	65	4-951-972-31 PANEL, BACK (UK)	
*	65	4-951-972-41 PANEL, BACK (E)	

Ref. No.	Part No.	Description	Remark
	66	4-947-010-01 SCREW, FEEDER FIXED	
\triangle	67	1-571-515-11 SWITCH, POWER VOLTAGE SELECTION (E)	
	68	3-655-653-21 BAND (TAITON), BINDING (UK, E)	
	69	4-923-836-11 CUSHION	
*	70	3-349-025-31 HOLDER, PC BOARD	
\triangle	71	1-569-007-11 ADAPTER, CONVERSION 2P (E)	
*	72	1-644-321-11 OUTLET BOARD (AEP, Germany)	
*	73	4-942-204-01 PLATE, GROUND	
\triangle	CNJ1	1-526-696-31 OUTLET, AC (3 GANG) (E)	
\triangle	CNJ1	1-526-751-00 OUTLET, AC (UK)	
\triangle	CNJ1	1-526-794-11 OUTLET, AC (AEP, Germany)	
\triangle	CP1	1-558-946-21 CORD, POWER (UK)	
\triangle	CP1	1-575-651-21 CORD, POWER (AEP, Germany)	
\triangle	CP1	1-575-653-21 CORD, POWER (E)	
\triangle	F1	1-532-259-00 FUSE, TIME-LAG (T1. 6A)	
\triangle	F2	1-532-286-00 FUSE, TIME-LAG (T2. 5A) (AEP, Germany, UK)	
\triangle	F3	1-532-259-00 FUSE, TIME-LAG (T1. 6A) (E)	
\triangle	T1	1-450-953-11 TRANSFORMER, POWER (AEP)	
\triangle	T1	1-450-954-11 TRANSFORMER, POWER (UK)	
\triangle	T1	1-450-955-11 TRANSFORMER, POWER (Germany)	
\triangle	T1	1-450-956-11 TRANSFORMER, POWER (E)	

SECTION 5 ELECTRICAL PARTS LIST

FUNCTION

FUSE

NOTE:

- Due to standardization, replacements in the parts list may be different from the parts specified in the diagrams or the components used on the set.
- -XX, -X mean standardized parts, so they may have some difference from the original one.
- RESISTORS
All resistors are in ohms
METAL: Metal-film resistor
METAL OXIDE: Metal oxide-film resistor
F: nonflammable

- Items marked "*" are not stocked since they are seldom required for routine service. Some delay should be anticipated when ordering these items.
- SEMICONDUCTORS
In each case, u; μ , for example:
uA.....: μ A....., uPA.....: μ PA.....
uPB.....: μ PB....., uPC.....: μ PC.....
uPD.....: μ PD.....
- CAPACITORS
uF: μ F
- COILS
uH: μ H

The components identified by mark Δ or dotted line with mark Δ are critical for safety. Replace only with part number specified.

When indicating parts by reference number, please include the board.

Ref. No.	Part No.	Description	Remark	Ref. No.	Part No.	Description	Remark
*	A-4347-667-A	FUNCTION BOARD, COMPLETE *****				< CONNECTOR >	
		< CONNECTOR >		* CN1	1-580-230-11	PIN, CONNECTOR (PC BOARD) 3P	
				CN2	1-564-321-00	PIN, CONNECTOR 2P	
* CNJ301	1-691-244-11	SOCKET, CONNECTOR 10P		* CN3	1-564-321-00	PIN, CONNECTOR 2P	
* CNJ302	1-691-244-11	SOCKET, CONNECTOR 10P		CN5	1-564-687-11	PIN, CONNECTOR 3P (E)	
		< DIODE >				< JACK >	
D707	8-719-987-63	DIODE 1N4148M		CNJ701	1-695-087-11	PIN, CONNECTOR (PC BOARD) 7P	
D708	8-719-987-63	DIODE 1N4148M		CNJ703	1-566-213-11	PIN, CONNECTOR 4P (CONTROL S OUT)	
D709	8-719-987-63	DIODE 1N4148M				< DIODE >	
D710	8-719-987-63	DIODE 1N4148M		D901	8-719-200-77	DIODE 10E2N	
D711	8-719-987-63	DIODE 1N4148M		D902	8-719-200-77	DIODE 10E2N	
D712	8-719-987-63	DIODE 1N4148M		D903	8-719-200-77	DIODE 10E2N	
D719	8-719-313-69	DIODE SEL3210S-CD		D904	8-719-200-77	DIODE 10E2N	
D720	8-719-313-72	LED SEL3810A-CD		D908	8-719-987-63	DIODE 1N4148M	
D722	8-719-313-72	LED SEL3810A-CD		D909	8-719-987-63	DIODE 1N4148M	
D723	8-719-018-46	LED SEL3510C-CD				< FUSE >	
D724	8-719-018-46	LED SEL3510C-CD		Δ F2	1-532-286-00	FUSE, TIME-LAG (T2. 5A) (AEP, Germany, UK)	
D725	8-719-018-46	LED SEL3510C-CD				< IC >	
D726	8-719-018-46	LED SEL3510C-CD		IC901	8-759-820-84	IC L78MRO5	
D727	8-719-018-46	LED SEL3510C-CD				< TRANSISTOR >	
		< IC >		Q713	8-729-620-05	TRANSISTOR 2SC2603-EF	
IC703	8-749-920-83	IC GP1U52XB				< RESISTOR >	
		*****		R735	1-249-425-11	CARBON 4.7K 5% 1/4W	
*	1-644-315-11	FUSE BOARD *****		R907	1-247-738-11	CARBON 82 5% 1/2W	
*	1-533-213-31	HOLDER, FUSE				< RELAY >	
		< CAPACITOR >		Δ RY1	1-515-516-00	RELAY	
Δ C1	1-161-744-00	CERAMIC 0.01uF 400V				< TRANSFORMER >	
C901	1-136-153-00	FILM 0.01uF 5% 50V		Δ T2	1-448-523-11	TRANSFORMER, POWER	
C902	1-124-557-11	ELECT 1000uF 20% 25V					
C903	1-124-903-11	ELECT 1uF 20% 50V					
C904	1-124-477-11	ELECT 47uF 20% 25V					
C919	1-161-494-00	CERAMIC 0.022uF 25V					

HEADPHONE

JOINT

MAIN

Ref. No.	Part No.	Description	Remark
*	1-644-317-11	HEADPHONE BOARD *****	
		< JACK >	
J501	1-507-863-51	JACK, PHONE (HEADPHONES)	
		< RESISTOR >	
R535	1-247-747-11	CARBON 470 5% 1/2W	
R635	1-247-747-11	CARBON 470 5% 1/2W	

*	1-644-311-11	JOINT BOARD *****	
		< CONNECTOR >	
CNJ702	1-568-319-11	SOCKET, CONNECTOR 8P	
CNP701	1-695-092-11	SOCKET, CONNECTOR 7P	

*	A-4347-660-A	MAIN BOARD, COMPLETE (E, AEP, UK)	
*	A-4347-661-A	MAIN BOARD, COMPLETE (Germany) *****	
*	4-942-204-01	PLATE, GROUND	
		< CAPACITOR >	
C501	1-124-927-11	ELECT 4.7uF 20% 100V	
C502	1-124-927-11	ELECT 4.7uF 20% 100V	
C503	1-162-282-31	CERAMIC 100PF 10% 50V (Germany)	
C504	1-161-375-00	CERAMIC 0.022uF 20% 50V	
C505	1-124-477-11	ELECT 47uF 20% 25V	
C506	1-162-193-31	CERAMIC 3.3PF 10% 50V	
C507	1-124-477-11	ELECT 47uF 20% 25V	
C508	1-124-477-11	ELECT 47uF 20% 25V	
C509	1-161-959-00	CERAMIC 22PF 10% 500V	
C510	1-161-959-00	CERAMIC 22PF 10% 500V	
C511	1-136-163-00	FILM 0.068uF 5% 50V	
C512	1-136-163-00	FILM 0.068uF 5% 50V	
C601	1-124-927-11	ELECT 4.7uF 20% 100V	
C602	1-124-927-11	ELECT 4.7uF 20% 100V	
C603	1-162-282-31	CERAMIC 100PF 10% 50V (Germany)	
C604	1-161-375-00	CERAMIC 0.022uF 20% 50V	
C605	1-124-477-11	ELECT 47uF 20% 25V	
C606	1-162-193-31	CERAMIC 3.3PF 10% 50V	
C607	1-124-477-11	ELECT 47uF 20% 25V	
C608	1-124-477-11	ELECT 47uF 20% 25V	
C609	1-161-959-00	CERAMIC 22PF 10% 500V	

Ref. No.	Part No.	Description	Remark
C610	1-161-959-00	CERAMIC 22PF 10% 500V	
C611	1-136-163-00	FILM 0.068uF 5% 50V	
C612	1-136-163-00	FILM 0.068uF 5% 50V	
C801	1-124-907-11	ELECT 10uF 20% 50V	
C802	1-124-477-11	ELECT 47uF 20% 25V	
C803	1-126-176-11	ELECT 220uF 20% 10V	
C804	1-124-907-11	ELECT 10uF 20% 50V	
C805	1-124-478-11	ELECT 100uF 20% 25V	
C905	1-136-165-00	FILM 0.1uF 5% 50V	
C906	1-136-165-00	FILM 0.1uF 5% 50V	
C907	1-126-138-11	ELECT 4700uF 20% 50V	
C908	1-126-138-11	ELECT 4700uF 20% 50V	
C909	1-124-913-11	ELECT 470uF 20% 50V	
C910	1-124-913-11	ELECT 470uF 20% 50V	
C915	1-124-484-11	ELECT 220uF 20% 35V	
C916	1-124-484-11	ELECT 220uF 20% 35V	
C917	1-124-477-11	ELECT 47uF 20% 25V	
C918	1-124-477-11	ELECT 47uF 20% 25V	
		< CONNECTOR >	
* CN301	1-564-512-11	PLUG, CONNECTOR 9P	
* CN302	1-564-513-11	PLUG, CONNECTOR 10P	
CN501	1-564-507-11	PLUG, CONNECTOR 4P	
* CN901	1-564-506-11	PLUG, CONNECTOR 3P	
CNJ101	1-568-321-11	SOCKET, CONNECTOR 10P	
CNJ102	1-568-321-11	SOCKET, CONNECTOR 10P	
		< DIODE >	
D501	8-719-933-36	DIODE HZS6B1L	
D502	8-719-987-63	DIODE 1N4148M	
D503	8-719-987-63	DIODE 1N4148M	
D504	8-719-987-63	DIODE 1N4148M	
D601	8-719-933-36	DIODE HZS6B1L	
D602	8-719-987-63	DIODE 1N4148M	
D603	8-719-987-63	DIODE 1N4148M	
D604	8-719-987-63	DIODE 1N4148M	
D801	8-719-200-77	DIODE 10E2N	
D802	8-719-987-63	DIODE 1N4148M	
D803	8-719-987-63	DIODE 1N4148M	
D905	8-719-302-38	DIODE RBV-602-01	
D906	8-719-200-77	DIODE 10E2N	
D907	8-719-200-77	DIODE 10E2N	
		< IC >	
IC801	8-759-111-68	IC uPC1237HA	
IC902	8-759-982-10	IC RC7809FA	
IC903	8-759-604-49	IC M5F7909L	

MAIN

Ref. No.	Part No.	Description	Remark	Ref. No.	Part No.	Description	Remark
< COIL >							
L501	1-420-872-00	COIL, AIR CORE		R513	1-249-433-11	CARBON 22K 5%	1/4W
L601	1-420-872-00	COIL, AIR CORE		R514	1-249-429-11	CARBON 10K 5%	1/4W
< TRANSISTOR >							
Q501	8-729-141-26	TRANSISTOR 2SC3622A-LK		R515	1-249-435-11	CARBON 33K 5%	1/4W
Q502	8-729-620-18	TRANSISTOR 2SA979-FG		R516	1-247-692-11	CARBON 22 5%	1/4W
Q503	8-729-140-82	TRANSISTOR 2SA988-PAFAEA		R517	1-249-425-11	CARBON 4.7K 5%	1/4W
Q504	8-729-620-05	TRANSISTOR 2SC2603-EF					
Q505	8-729-620-05	TRANSISTOR 2SC2603-EF		R518	1-249-419-11	CARBON 1.5K 5%	1/4W
Q506	8-729-803-76	TRANSISTOR 2SA1371-E		R519	1-247-692-11	CARBON 22 5%	1/4W
Q507	8-729-209-15	TRANSISTOR 2SD2012		R520	1-247-700-11	CARBON 100 5%	1/4W
Q508	8-729-142-01	TRANSISTOR 2SC1941-LK		R521	1-247-700-11	CARBON 100 5%	1/4W
Q509	8-729-141-46	TRANSISTOR 2SC4431-LK		R522	1-247-706-11	CARBON 330 5%	1/4W
Q510	8-729-141-37	TRANSISTOR 2SA1684-LK					
Q511	8-729-015-83	TRANSISTOR 2SC3853-OPY		R523	1-249-455-11	CARBON 4.7 5%	1/4W
Q512	8-729-015-80	TRANSISTOR 2SA1489-OPY		R524	1-249-455-11	CARBON 4.7 5%	1/4W
Q513	8-729-140-84	TRANSISTOR 2SC1841-PAFAEA		R525	1-216-361-00	METAL OXIDE 0.22 5%	2W F
Q514	8-729-224-62	TRANSISTOR 2SK246-GR		R526	1-216-361-00	METAL OXIDE 0.22 5%	2W F
Q601	8-729-141-26	TRANSISTOR 2SC3622A-LK		R527	1-247-704-11	CARBON 220 5%	1/4W
Q602	8-729-620-18	TRANSISTOR 2SA979-FG					
Q603	8-729-140-82	TRANSISTOR 2SA988-PAFAEA		R528	1-249-427-11	CARBON 6.8K 5%	1/4W
Q604	8-729-620-05	TRANSISTOR 2SC2603-EF		R529	1-247-727-11	CARBON 10 5%	1/2W
Q605	8-729-620-05	TRANSISTOR 2SC2603-EF		R530	1-247-727-11	CARBON 10 5%	1/2W
Q606	8-729-803-76	TRANSISTOR 2SA1371-E		R531	1-249-437-11	CARBON 47K 5%	1/4W
Q607	8-729-209-15	TRANSISTOR 2SD2012		R536	1-249-409-11	CARBON 220 5%	1/4W
Q608	8-729-142-01	TRANSISTOR 2SC1941-LK					
Q609	8-729-141-46	TRANSISTOR 2SC4431-LK		R537	1-249-417-11	CARBON 1K 5%	1/4W
Q610	8-729-141-37	TRANSISTOR 2SA1684-LK		R538	1-249-423-11	CARBON 3.3K 5%	1/4W
Q611	8-729-015-83	TRANSISTOR 2SC3853-OPY		R601	1-249-423-11	CARBON 3.3K 5%	1/4W
Q612	8-729-015-80	TRANSISTOR 2SA1489-OPY		R602	1-249-417-11	CARBON 1K 5%	1/4W
Q613	8-729-140-84	TRANSISTOR 2SC1841-PAFAEA		R603	1-249-421-11	CARBON 2.2K 5%	1/4W
Q614	8-729-224-62	TRANSISTOR 2SK246-GR					
Q801	8-729-900-63	TRANSISTOR DTA124ES		R604	1-249-393-11	CARBON 10 5%	1/4W
< RESISTOR >							
R501	1-249-423-11	CARBON 3.3K 5%	1/4W	R606	1-247-704-11	CARBON 220 5%	1/4W
R502	1-249-417-11	CARBON 1K 5%	1/4W	R607	1-247-704-11	CARBON 220 5%	1/4W
R503	1-249-421-11	CARBON 2.2K 5%	1/4W	R608	1-249-490-11	CARBON 27K 5%	1/2W
R504	1-249-393-11	CARBON 10 5%	1/4W	R609	1-249-413-11	CARBON 470 5%	1/4W
R506	1-247-704-11	CARBON 220 5%	1/4W				
R507	1-247-704-11	CARBON 220 5%	1/4W	R610	1-249-438-11	CARBON 56K 5%	1/4W
R508	1-249-490-11	CARBON 27K 5%	1/2W	R611	1-249-438-11	CARBON 56K 5%	1/4W
R509	1-249-413-11	CARBON 470 5%	1/4W	R613	1-249-433-11	CARBON 22K 5%	1/4W
R510	1-249-438-11	CARBON 56K 5%	1/4W	R614	1-249-429-11	CARBON 10K 5%	1/4W
R511	1-249-438-11	CARBON 56K 5%	1/4W	R615	1-249-435-11	CARBON 33K 5%	1/4W
				R616	1-247-692-11	CARBON 22 5%	1/4W
				R617	1-249-425-11	CARBON 4.7K 5%	1/4W
				R618	1-249-419-11	CARBON 1.5K 5%	1/4W
				R619	1-247-692-11	CARBON 22 5%	1/4W
				R620	1-247-700-11	CARBON 100 5%	1/4W
				R621	1-247-700-11	CARBON 100 5%	1/4W
				R622	1-247-706-11	CARBON 330 5%	1/4W
				R623	1-249-455-11	CARBON 4.7 5%	1/4W
				R624	1-249-455-11	CARBON 4.7 5%	1/4W
				R625	1-216-361-00	METAL OXIDE 0.22 5%	2W F
				R626	1-216-361-00	METAL OXIDE 0.22 5%	2W F
				R627	1-247-704-11	CARBON 220 5%	1/4W
				R628	1-249-427-11	CARBON 6.8K 5%	1/4W
				R629	1-247-727-11	CARBON 10 5%	1/2W

MAIN

OUTLET

PANEL

Ref. No.	Part No.	Description	Remark		
R630	1-247-727-11	CARBON	10	5%	1/2W
R631	1-249-438-11	CARBON	56K	5%	1/4W
R636	1-249-409-11	CARBON	220	5%	1/4W
R637	1-249-417-11	CARBON	1K	5%	1/4W
R638	1-249-423-11	CARBON	3.3K	5%	1/4W
R801	1-249-427-11	CARBON	6.8K	5%	1/4W
R802	1-249-441-11	CARBON	100K	5%	1/4W
R803	1-249-428-11	CARBON	8.2K	5%	1/4W
R804	1-249-439-11	CARBON	68K	5%	1/4W
R805	1-249-430-11	CARBON	12K	5%	1/4W
R806	1-215-869-11	METAL OXIDE	1K	5%	1W F
R905	1-249-385-11	CARBON	2.2	5%	1/6W
R906	1-249-385-11	CARBON	2.2	5%	1/6W
R913	1-216-478-11	METAL OXIDE	390	5%	3W F (E, AEP, UK)
R913	1-216-477-11	METAL OXIDE	270	5%	3W F (Germany)
R916	1-215-915-11	METAL OXIDE	470	5%	3W F (E, AEP, UK)
R916	1-216-478-11	METAL OXIDE	390	5%	3W F (Germany)
< VARIABLE RESISTOR >					
RV501	1-238-011-11	RES, ADJ, CARBON 470 (DC BIAS L-CH)			
RV601	1-238-011-11	RES, ADJ, CARBON 470 (DC BIAS R-CH)			
< RELAY >					
RY801	1-515-533-11	RELAY			

*	1-644-321-11	OUTLET BOARD (AEP, Germany)			

< OUTLET >					
△	1-526-794-11	OUTLET, AC (AEP, Germany)			

*	A-4347-665-A	PANEL BOARD, COMPLETE			

< CAPACITOR >					
C301	1-130-481-00	MYLAR	0.0068uF	5%	50V
C302	1-130-474-00	MYLAR	0.0018uF	5%	50V
C303	1-136-159-00	FILM	0.033uF	5%	50V
C304	1-130-479-00	MYLAR	0.0047uF	5%	50V
C401	1-130-481-00	MYLAR	0.0068uF	5%	50V
C402	1-130-474-00	MYLAR	0.0018uF	5%	50V
C403	1-136-159-00	FILM	0.033uF	5%	50V
C404	1-130-479-00	MYLAR	0.0047uF	5%	50V
C708	1-161-494-00	CERAMIC	0.022uF		25V
C709	1-161-494-00	CERAMIC	0.022uF		25V

Ref. No.	Part No.	Description	Remark		
C710	1-162-284-31	CERAMIC	150PF	10%	50V
C711	1-162-284-31	CERAMIC	150PF	10%	50V
C712	1-124-477-11	ELECT	47uF	20%	25V
C713	1-161-494-00	CERAMIC	0.022uF		25V
C714	1-136-165-00	FILM	0.1uF	5%	50V
C715	1-124-477-11	ELECT	47uF	20%	25V
C717	1-161-494-00	CERAMIC	0.022uF		25V
C718	1-124-477-11	ELECT	47uF	20%	25V
< CONNECTOR >					
CNP301	1-695-415-11	PIN, CONNECTOR (PC BOARD)	10P		
CNP302	1-695-415-11	PIN, CONNECTOR (PC BOARD)	10P		
* CNP702	1-568-320-11	PLUG, CONNECTOR	8P		
< DIODE >					
D713	8-719-987-63	DIODE	1N4148M		
D714	8-719-987-63	DIODE	1N4148M		
D715	8-719-987-63	DIODE	1N4148M		
D716	8-719-987-63	DIODE	1N4148M		
D717	8-719-987-63	DIODE	1N4148M		
D718	8-719-987-63	DIODE	1N4148M		
D728	8-719-987-63	DIODE	1N4148M		
< IC >					
IC702	8-759-077-08	IC	M50761-291P		
IC704	8-759-820-62	IC	LB1639		
< TRANSISTOR >					
Q707	8-729-904-39	TRANSISTOR	DTC114TS		
Q708	8-729-904-39	TRANSISTOR	DTC114TS		
Q709	8-729-900-63	TRANSISTOR	DTA124ES		
Q710	8-729-806-30	TRANSISTOR	2SC4048		
Q711	8-729-900-80	TRANSISTOR	DTC114ES		
Q712	8-729-620-05	TRANSISTOR	2SC2603-EF		
< RESISTOR >					
R302	1-249-421-11	CARBON	2.2K	5%	1/4W
R303	1-249-426-11	CARBON	5.6K	5%	1/4W
R304	1-247-903-00	CARBON	1M	5%	1/4W
R305	1-247-903-00	CARBON	1M	5%	1/4W
R306	1-247-852-11	CARBON	7.5K	5%	1/4W
R308	1-247-870-11	CARBON	43K	5%	1/4W
R309	1-249-436-11	CARBON	39K	5%	1/4W
R310	1-249-437-11	CARBON	47K	5%	1/4W
R402	1-249-421-11	CARBON	2.2K	5%	1/4W
R403	1-249-426-11	CARBON	5.6K	5%	1/4W
R404	1-247-903-00	CARBON	1M	5%	1/4W
R405	1-247-903-00	CARBON	1M	5%	1/4W
R406	1-247-852-11	CARBON	7.5K	5%	1/4W

Note: The components identified by mark △ or dotted line with mark △ are critical for safety. Replace only with part number specified.

PANEL

PIN JACK

Ref. No.	Part No.	Description	Remark
R408	1-247-870-11	CARBON	43K 5% 1/4W
R409	1-249-436-11	CARBON	39K 5% 1/4W
R410	1-249-437-11	CARBON	47K 5% 1/4W
R708	1-249-414-11	CARBON	560 5% 1/4W
R709	1-249-411-11	CARBON	330 5% 1/4W
R710	1-249-411-11	CARBON	330 5% 1/4W
R711	1-249-411-11	CARBON	330 5% 1/4W
R712	1-249-411-11	CARBON	330 5% 1/4W
R713	1-249-411-11	CARBON	330 5% 1/4W
R714	1-249-433-11	CARBON	22K 5% 1/4W
R715	1-249-433-11	CARBON	22K 5% 1/4W
R716	1-249-433-11	CARBON	22K 5% 1/4W
R717	1-249-433-11	CARBON	22K 5% 1/4W
R718	1-249-433-11	CARBON	22K 5% 1/4W
R719	1-249-433-11	CARBON	22K 5% 1/4W
R720	1-249-433-11	CARBON	22K 5% 1/4W
R721	1-247-903-00	CARBON	1M 5% 1/4W
R722	1-249-423-11	CARBON	3.3K 5% 1/4W
R723	1-249-429-11	CARBON	10K 5% 1/4W
R724	1-249-417-11	CARBON	1K 5% 1/4W
R725	1-249-417-11	CARBON	1K 5% 1/4W
R726	1-249-393-11	CARBON	10 5% 1/4W
R727	1-249-425-11	CARBON	4.7K 5% 1/4W
R728	1-249-412-11	CARBON	390 5% 1/4W
R729	1-249-417-11	CARBON	1K 5% 1/4W
R730	1-249-421-11	CARBON	2.2K 5% 1/4W
R731	1-249-421-11	CARBON	2.2K 5% 1/4W
R732	1-247-750-11	CARBON	680 5% 1/2W
R733	1-249-441-11	CARBON	100K 5% 1/4W
R734	1-249-425-11	CARBON	4.7K 5% 1/4W
R736	1-249-419-11	CARBON	1.5K 5% 1/4W
< VARIABLE RESISTOR >			
RV301	1-238-513-11	RES, VAR, CARBON 150K/150K (BALANCE)	
RV302	1-238-514-11	RES, VAR 250K/250K (TREBLE)	
RV303	1-238-515-11	RES, VAR, CARBON 520K/520K (BASS)	
< SWITCH >			
S301	1-572-642-11	SWITCH, PUSH (1 KEY) (SOURCE DIRECT)	
S701	1-554-303-21	SWITCH, TACTILE (POWER)	
S702	1-554-303-21	SWITCH, TACTILE (DAT/TAPE1)	
S703	1-554-303-21	SWITCH, TACTILE (TAPE2)	
S704	1-554-303-21	SWITCH, TACTILE (AUX)	
S705	1-554-303-21	SWITCH, TACTILE (CD)	
S706	1-554-303-21	SWITCH, TACTILE (TUNER)	
S707	1-554-303-21	SWITCH, TACTILE (PHONO)	
< VIBRATOR >			
X701	1-577-077-11	VIBLATOR, CERAMIC	

Ref. No.	Part No.	Description	Remark
*	A-4347-662-A	PIN JACK BOARD, COMPLETE (E, AEP, UK)	
*	A-4347-663-A	PIN JACK BOARD, COMPLETE (Germany)	

< CAPACITOR >			
C101	1-162-284-31	CERAMIC	150PF 10% 50V (Germany)
C102	1-162-284-31	CERAMIC	150PF 10% 50V (Germany)
C103	1-162-284-31	CERAMIC	150PF 10% 50V (Germany)
C104	1-162-284-31	CERAMIC	150PF 10% 50V (Germany)
C105	1-162-284-31	CERAMIC	150PF 10% 50V (Germany)
C106	1-162-284-31	CERAMIC	150PF 10% 50V (Germany)
C107	1-162-284-31	CERAMIC	150PF 10% 50V (Germany)
C108	1-162-285-31	CERAMIC	180PF 10% 50V
C109	1-162-282-31	CERAMIC	100PF 10% 50V (Germany)
C110	1-124-907-11	ELECT	10uF 20% 50V
C111	1-124-477-11	ELECT	47uF 20% 25V
C112	1-162-282-31	CERAMIC	100PF 10% 50V (AEP, UK, E)
C112	1-162-284-31	CERAMIC	150PF 10% 50V (Germany)
C113	1-130-480-00	MYLAR	0.0056uF 5% 50V
C114	1-130-473-00	MYLAR	0.0015uF 5% 50V
C115	1-124-927-11	ELECT	4.7uF 20% 100V
C116	1-124-477-11	ELECT	47uF 20% 25V
C117	1-124-925-11	ELECT	2.2uF 20% 100V
C201	1-162-284-31	CERAMIC	150PF 10% 50V (Germany)
C202	1-162-284-31	CERAMIC	150PF 10% 50V (Germany)
C203	1-162-284-31	CERAMIC	150PF 10% 50V (Germany)
C204	1-162-284-31	CERAMIC	150PF 10% 50V (Germany)
C205	1-162-284-31	CERAMIC	150PF 10% 50V (Germany)
C206	1-162-284-31	CERAMIC	150PF 10% 50V (Germany)
C207	1-162-284-31	CERAMIC	150PF 10% 50V (Germany)
C208	1-162-285-31	CERAMIC	180PF 10% 50V
C209	1-162-282-31	CERAMIC	100PF 10% 50V (Germany)
C210	1-124-907-11	ELECT	10uF 20% 50V
C211	1-124-477-11	ELECT	47uF 20% 25V
C212	1-162-282-31	CERAMIC	100PF 10% 50V (AEP, UK, E)
C212	1-162-284-31	CERAMIC	150PF 10% 50V (Germany)
C213	1-130-480-00	MYLAR	0.0056uF 5% 50V
C214	1-130-473-00	MYLAR	0.0015uF 5% 50V
C215	1-124-927-11	ELECT	4.7uF 20% 100V
C216	1-124-477-11	ELECT	47uF 20% 25V
C701	1-124-472-11	ELECT	470uF 20% 10V
C702	1-161-494-00	CERAMIC	0.022uF 25V
C703	1-161-494-00	CERAMIC	0.022uF 25V
C704	1-124-477-11	ELECT	47uF 20% 25V
C705	1-161-494-00	CERAMIC	0.022uF 25V

PIN JACK

SP. SW.

SP. TM.

Ref. No.	Part No.	Description	Remark
< CONNECTOR >			
* CNP101	1-568-322-21	PLUG, CONNECTOR 10P	
* CNP102	1-568-322-21	PLUG, CONNECTOR 10P	
< DIODE >			
D701	8-719-200-77	DIODE 10E2N	
D702	8-719-200-77	DIODE 10E2N	
D703	8-719-987-63	DIODE 1N4148M	
D704	8-719-987-63	DIODE 1N4148M	
D705	8-719-933-33	DIODE HZS6A1L	
D706	8-719-987-63	DIODE 1N4148M	
< IC >			
IC101	8-759-636-74	IC M5218AP-22	
IC102	8-759-801-01	IC LC4966	
IC701	8-759-802-52	IC LC7818	
< JACK >			
J101	1-573-141-21	JACK 2P (PHONO)	
* J102	1-573-142-21	JACK, PIN 4P (DAT/TAPE1)	
* J103	1-573-142-21	JACK, PIN 4P (TAPE2)	
J104	1-568-978-11	JACK 6P (TUNER/CD/AUX)	
< TRANSISTOR >			
Q101	8-729-900-36	TRANSISTOR DTC124ES	
Q102	8-729-900-63	TRANSISTOR DTA124ES	
Q701	8-729-119-76	TRANSISTOR 2SA1175-HFE	
Q702	8-729-900-63	TRANSISTOR DTA124ES	
Q703	8-729-900-63	TRANSISTOR DTA124ES	
Q704	8-729-900-63	TRANSISTOR DTA124ES	
Q705	8-729-900-63	TRANSISTOR DTA124ES	
Q706	8-729-900-63	TRANSISTOR DTA124ES	
< RESISTOR >			
R101	1-249-409-11	CARBON 220 5% 1/4W (Germany)	
R102	1-249-417-11	CARBON 1K 5% 1/4W	
R103	1-249-409-11	CARBON 220 5% 1/4W (Germany)	
R104	1-249-417-11	CARBON 1K 5% 1/4W	
R105	1-249-409-11	CARBON 220 5% 1/4W (Germany)	
R106	1-249-409-11	CARBON 220 5% 1/4W (Germany)	
R107	1-249-409-11	CARBON 220 5% 1/4W (Germany)	
R108	1-249-418-11	CARBON 1.2K 5% 1/4W	
R109	1-249-418-11	CARBON 1.2K 5% 1/4W (Germany)	
R110	1-249-441-11	CARBON 100K 5% 1/4W	
R111	1-249-416-11	CARBON 820 5% 1/4W	
R112	1-247-897-11	CARBON 560K 5% 1/4W	
R113	1-249-437-11	CARBON 47K 5% 1/4W	
R114	1-249-409-11	CARBON 220 5% 1/4W	
R115	1-249-441-11	CARBON 100K 5% 1/4W	

Ref. No.	Part No.	Description	Remark
R116	1-249-441-11	CARBON 100K 5% 1/4W	
R117	1-249-433-11	CARBON 22K 5% 1/4W	
R118	1-249-433-11	CARBON 22K 5% 1/4W	
R119	1-249-441-11	CARBON 100K 5% 1/4W	
R201	1-249-409-11	CARBON 220 5% 1/4W (Germany)	
R202	1-249-417-11	CARBON 1K 5% 1/4W	
R203	1-249-409-11	CARBON 220 5% 1/4W (Germany)	
R204	1-249-417-11	CARBON 1K 5% 1/4W	
R205	1-249-409-11	CARBON 220 5% 1/4W (Germany)	
R206	1-249-409-11	CARBON 220 5% 1/4W (Germany)	
R207	1-249-409-11	CARBON 220 5% 1/4W (Germany)	
R208	1-249-418-11	CARBON 1.2K 5% 1/4W	
R209	1-249-418-11	CARBON 1.5K 5% 1/4W (Germany)	
R210	1-249-441-11	CARBON 100K 5% 1/4W	
R211	1-249-416-11	CARBON 820 5% 1/4W	
R212	1-247-897-11	CARBON 560K 5% 1/4W	
R213	1-249-437-11	CARBON 47K 5% 1/4W	
R214	1-249-409-11	CARBON 220 5% 1/4W	
R215	1-249-441-11	CARBON 100K 5% 1/4W	
R216	1-249-441-11	CARBON 100K 5% 1/4W	
R301	1-249-405-11	CARBON 100 5% 1/4W	
R401	1-249-405-11	CARBON 100 5% 1/4W	
R701	1-247-901-11	CARBON 820K 5% 1/4W	
R702	1-249-433-11	CARBON 22K 5% 1/4W	
R703	1-249-441-11	CARBON 100K 5% 1/4W	
R704	1-249-433-11	CARBON 22K 5% 1/4W	
R705	1-249-429-11	CARBON 10K 5% 1/4W	
R706	1-249-429-11	CARBON 10K 5% 1/4W	
R707	1-249-433-11	CARBON 22K 5% 1/4W	
R732	1-249-433-11	CARBON 22K 5% 1/4W	

* 1-644-316-11	SP. SW. BOARD	*****	
< SWITCH >			
S501	1-692-168-11	SWITCH, ROTARY SLIDE (SPEAKER)	

* 1-644-319-11	SP. TM. BOARD	*****	
< CAPACITOR >			
C513	1-136-157-00	FILM 0.022uF 5% 50V (Germany)	
C514	1-136-157-00	FILM 0.022uF 5% 50V (Germany)	
C515	1-136-157-00	FILM 0.022uF 5% 50V (Germany)	
C516	1-136-157-00	FILM 0.022uF 5% 50V (Germany)	
C517	1-136-157-00	FILM 0.022uF 5% 50V (Germany)	

SP. TM.

TRANSFORMER (A)

TRANSFORMER (B)

VOL

Ref. No.	Part No.	Description	Remark
C613	1-136-157-00	FILM 0.022uF 5% 50V (Germany)	
C614	1-136-157-00	FILM 0.022uF 5% 50V (Germany)	
C615	1-136-157-00	FILM 0.022uF 5% 50V (Germany)	
C616	1-136-157-00	FILM 0.022uF 5% 50V (Germany)	
C617	1-136-157-00	FILM 0.022uF 5% 50V (Germany)	

< CONNECTOR >

* CN502 1-564-509-11 PLUG, CONNECTOR 6P

< RESISTOR >

R532	1-247-727-11	CARBON 10 5% 1/2W (Germany)
R533	1-247-727-11	CARBON 10 5% 1/2W (Germany)
R632	1-247-727-11	CARBON 10 5% 1/2W (Germany)
R633	1-247-727-11	CARBON 10 5% 1/2W (Germany)

< TERMINAL >

TM501	1-537-235-11	TERMINAL BOARD (SP) (E, AEP1, UK)
TM501	1-537-227-11	TERMINAL BOARD (SP) (AEP2)
TM501	1-537-228-11	TERMINAL BOARD (SP) (Germany)

* 1-644-318-11 TRANSFORMER (A) BOARD

* 1-533-213-31 HOLDER, FUSE

< CONNECTOR >

* CN4 1-580-633-11 PIN, CONNECTOR 5P (E)

< FUSE >

△F1	1-532-259-00	FUSE, TIME-LAG (T1. 6A)
△F3	1-532-259-00	FUSE, TIME-LAG (T1. 6A) (E)

* 1-644-320-11 TRANSFORMER (B) BOARD

NOTE:

●AEP2: Model for Scandinavian countries, Switzerland, Spain and Portugal

●AEP1: Model for other European countries

Ref. No.	Part No.	Description	Remark
----------	----------	-------------	--------

* 1-644-313-11 VOL BOARD

< CAPACITOR >

C719 1-136-165-00 FILM 0.1uF 5% 50V

< VARIABLE RESISTOR >

RV304 1-241-921-11 RES, VAR, CARBON 120K/120K (VOLUME)

MISCELLANEOUS

△67 1-571-515-11 SWITCH, POWER VOLTAGE SELECTION (E)

△71 1-569-007-11 ADAPTER, CONVERSION 2P (E)

△CNJ1 1-526-696-31 OUTLET, AC (3 GANG) (E)

△CNJ1 1-526-751-00 OUTLET, AC (UK)

△CP1 1-558-946-21 CORD, POWER (UK)

△CP1 1-575-651-21 CORD, POWER (AEP, Germany)

△CP1 1-575-653-21 CORD, POWER (E)

△T1 1-450-953-11 TRANSFORMER, POWER (AEP)

△T1 1-450-954-11 TRANSFORMER, POWER (UK)

△T1 1-450-955-11 TRANSFORMER, POWER (Germany)

△T1 1-450-956-11 TRANSFORMER, POWER (E)

ACCESSORIES & PACKING MATERIALS

1-693-131-11 REMOTE COMMANDER (RM-S311)

2-181-754-01 COVER, BATTERY (REMOTE COMMANDER)

3-755-074-11 MANUAL, INSTRUCTION (E, AEP, UK)

(ENGLISH/FRENCH/SPANISH/PORTUGUESE)

3-755-074-41 MANUAL, INSTRUCTION (AEP, Germany)

(GERMAN/DUTCH/SWEDISH/ITALIAN)

* 4-945-810-02 CUSHION (LEFT)

* 4-945-811-01 CUSHION (RIGHT)

* 4-951-289-01 INDIVIDUAL CARTON

HARDWARE LIST

#1 7-682-548-09 SCREW +B 3X8

#3 7-685-646-79 SCREW +BVTP 3X8 TYPE2 N-S

#4 7-685-648-79 SCREW +BVTP 3X12 TYPE2

#5 7-621-849-00 SCREW (BV/RING)

#6 7-682-560-04 SCREW +BVTT 4X6 (S)

#7 7-685-647-79 SCREW +BVTP 3X10 TYPE2 IT-3

Note: The components identified by mark △ or dotted line with mark △ are critical for safety. Replace only with part number specified.