

# TA-F420/F420A

## SERVICE MANUAL

AEP Model  
UK Model  
TA-F420A

Canadian Model  
West Germany Model  
E Model  
TA-F420

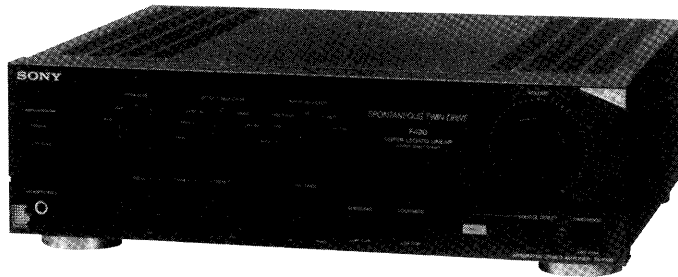

photo : TA-F420

### SPECIFICATIONS

#### Amplifier

Continuous RMS power output (both channels driven simultaneously)

TA-F420A : AEP, UK MODEL

DIN, 1 kHz	4 ohms	90 W + 90 W
	8 ohms	90 W + 90 W
20 Hz - 20 kHz THD 0.05%	8 ohms	70 W + 70 W

TA-F420 : Canadian, West Germany, E Model

DIN, 1 kHz, 8 ohms	90 W + 90 W
20 Hz - 20 kHz THD 0.05%, 8 ohms	70 W + 70 W

#### Input

Input jack		Jack type	Sensitivity	Impedance	S/N (weighting network, input level)
PHONO	MM	Phono	2.0 mV	50 kilohms	83 dB (A, 2.5 mV)
	MC		170 $\mu$ V	100 ohms	73 dB (A, 2.5 mV)
TUNER, CD, VIDEO/AUX, TAPE/DAT		Phono	150 mV	50 kilohms	100 dB (150 mV)

#### Output

Output jack	Jack type	Voltage/impedance
REC OUT	Phono	Voltage 150 mV Impedance 1 kohms
SPEAKERS	—	AEP, UK Model : Accepts speakers of 4 - 6 ohms/8 - 16 ohms. Canadian, West Germany, E Model : Accepts speakers of 8 - 16 ohms.
HEAD-PHONES	Stereo phone	Accepts low and high impedance headphones.

#### Tone controls

	Response	Turnover frequency
BASS	$\pm$ 10 dB (100 Hz)	500 Hz
TREBLE	$\pm$ 10 dB (15 kHz)	3 kHz

#### Loudness (Attenuation 30 dB)

+6 dB (100 Hz)  
+3 dB (10 kHz)

Subsonic filter 6 dB/octave, attenuation below 15Hz  
Harmonic distortion Less than 0.05% at rated output  
Intermodulation (IM) distortion (60 Hz:7 kHz = 4:1)  
Less than 0.05% at rated output

- Continued on next page -

# INTEGRATED STEREO AMPLIFIER

# SONY®



Frequency response

PHONO: RIAA equalization curve  
 ±0.5 dB  
 TUNER, CD, VIDEO/AUX, TAPE1,  
 TAPE2/DAT: 7 Hz – 100 kHz ±3 dB

Residual noise  
 Damping factor

Less than 170 μV (network A)  
 40 (8 ohms, 1 kHz)

General

System

Preamplifier: Low-noise, high-gain  
 equalizer amplifier  
 Power amplifier: Pure-complementary  
 SEPP OCL power amplifier with all  
 stages directly coupled

Power requirements

AEP, West Germany Model :  
 220 V AC, 50 Hz  
 U.K. model: 240 V AC, 50 Hz  
 Canadian Model : 120 V AC, 60 Hz  
 E Model : 120 V,  
 220 V or 240 V AC adjustable,  
 50/60Hz

Power consumption

AEP, West Germany Model : 160 W  
 UK Model : 370 W  
 Canadian Model : 315 VA  
 E Model : 155 W

Dimensions

Approx. 430 × 135 × 375 mm (w/h/d)  
 (17 × 5 3/8 × 14 7/8 inches)

Weight

Approx. 8.9 kg (19 lb 10 oz)

Design and specifications subject to change without notice.

Note

This appliance conforms with EEC directive 87/308/EEC regarding interference suppression.

MODEL IDENTIFICATION

— Specification Label —

AEP, UK Model : TA-F420A  
 West Germany, Canadian, E Model : TA-F420

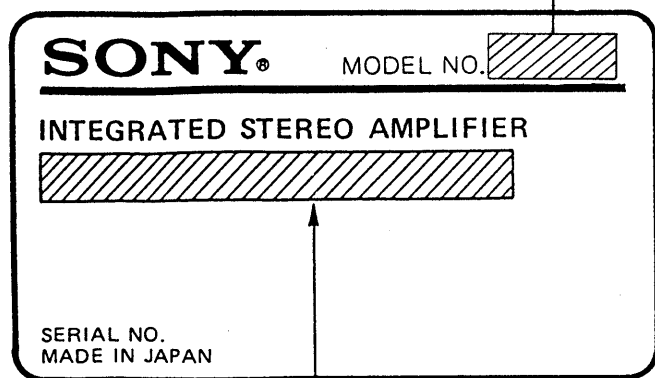

AEP, West Germany Model: AC: 220V~50/60Hz 160W  
 UK Model: AC: 240V~50/60Hz 370W  
 Canadian Model: AC: 120V 60H 315VA  
 E Model: AC: 120/220/240V~  
 50/60Hz 160W

SAFETY CHECK-OUT

After correcting the original service problem, perform the following safety check before releasing the set to the customer:

Check the antenna terminals, metal trim, “metallized” knobs, screws, and all other exposed metal parts for AC leakage. Check leakage as described below.

LEAKAGE TEST

The AC leakage from any exposed metal part to earth ground and from all exposed metal parts to any exposed metal part having a return to chassis, must not exceed 0.5 mA (500 microamperes). Leakage current can be measured by any one of three methods.

1. A commercial leakage tester, such as the Simpson 229 or RCA WT-540A. Follow the manufacturers’ instructions to use these instruments.
2. A battery-operated AC milliammeter. The Data Precision 245 digital multimeter is suitable for this job.
3. Measuring the voltage drop across a resistor by means of a VOM or battery-operated AC voltmeter. The “limit” indication is 0.75 V, so analog meters must have an accurate low-voltage scale. The Simpson 250 and Sanwa SH-63Trd are examples of a passive VOM that is suitable. Nearly all battery operated digital multimeters that have a 2V AC range are suitable. (See Fig. A)

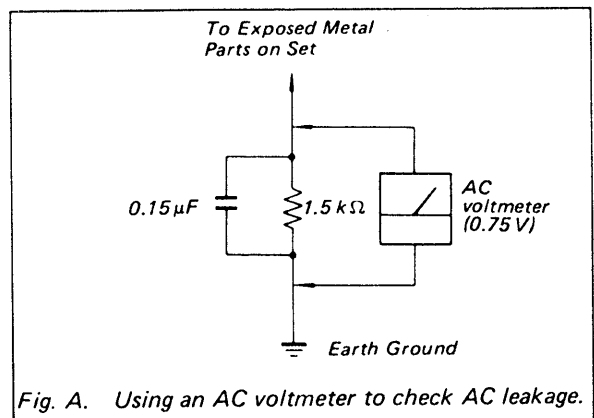

Fig. A. Using an AC voltmeter to check AC leakage.

SAFETY-RELATED COMPONENT WARNING!!

COMPONENTS IDENTIFIED BY MARK OR DOTTED LINE WITH MARK ON THE SCHEMATIC DIAGRAMS AND IN THE PARTS LIST ARE CRITICAL TO SAFE OPERATION. REPLACE THESE COMPONENTS WITH SONY PARTS WHOSE PART NUMBERS APPEAR AS SHOWN IN THIS MANUAL OR IN SUPPLEMENTS PUBLISHED BY SONY.

ATTENTION AU COMPOSANT AYANT RAPPORT À LA SÉCURITÉ!

LES COMPOSANTS IDENTIFIÉS PAR UNE MARQUE SUR LES DIAGRAMMES SCHÉMATIQUES ET LA LISTE DES PIÈCES SONT CRITIQUES POUR LA SÉCURITÉ DE FONCTIONNEMENT. NE REMPLACER CES COMPOSANTS QUE PAR DES PIÈCES SONY DONT LES NUMÉROS SONT DONNÉS DANS CE MANUEL OU DANS LES SUPPLÉMENTS PUBLIÉS PAR SONY.

# SECTION 1 GENERAL

## Precautions

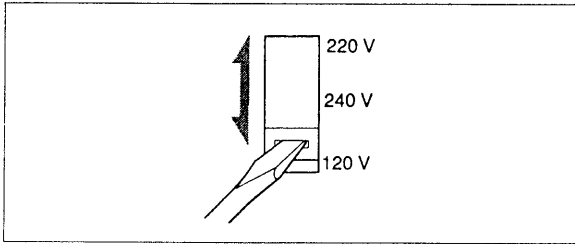

### On operating voltage

Before operating the unit, check that the operating voltage of your unit is identical with the voltage of your local power supply.

Where purchased	Operating voltage
Canadian Model	120 V AC
UK Model	240 V AC
AEP, West Germany Model	220 V AC
E Model	120 V, 220 V or 240 V AC adjustable The voltage selector is located on the rear panel. If the selector must be reset, disconnect the AC power cord and set the selector to the proper voltage of your local power supply.

## PARTS IDENTIFICATIONS

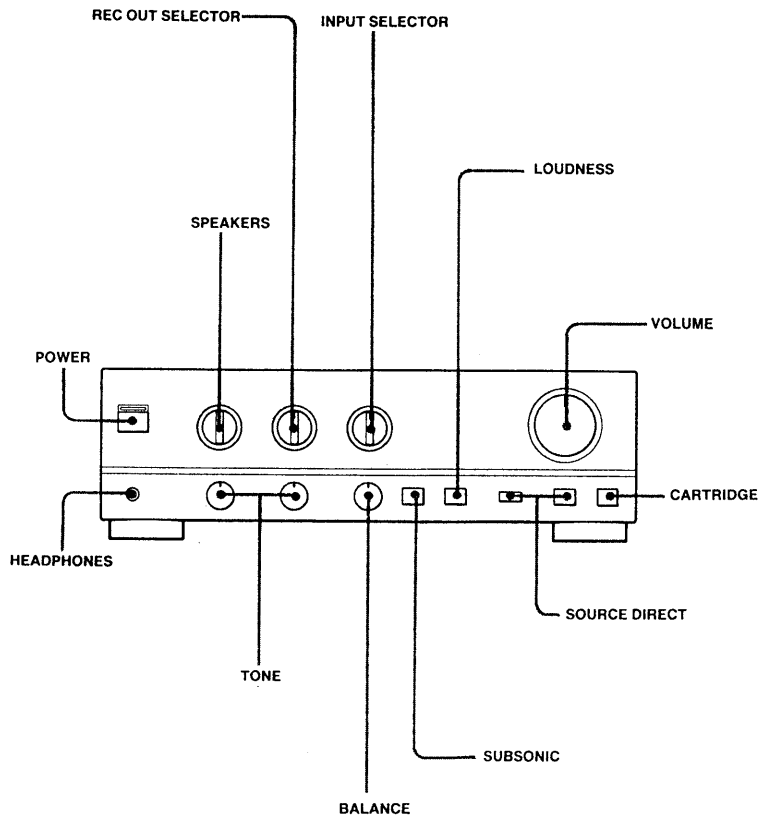

# Connections

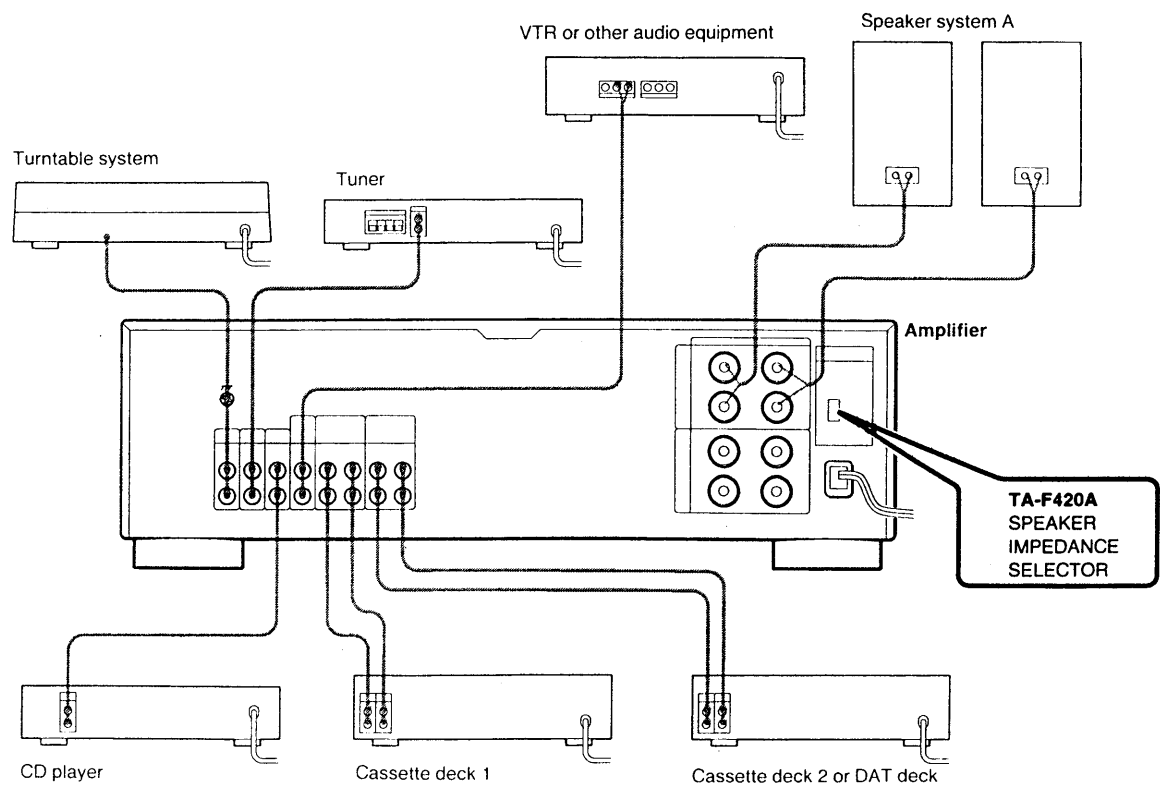

REVISED

## SECTION 2 ELECTRICAL ADJUSTMENTS

**NOTE :**

• Adjustment should be performed 10 minutes after the POWER switch is on (POWER ON).

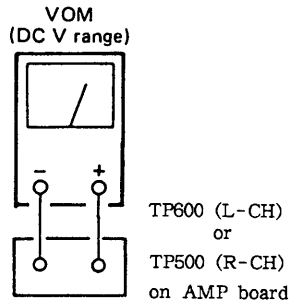

**Adjustment Location:**

AMP BOARD – Component Side –

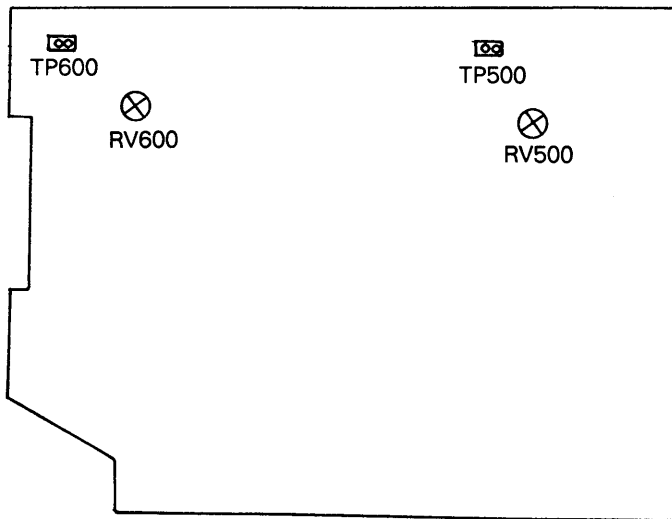

### Bias Current Adjustment

**Note :** This adjustment should be performed under thermal stable condition. Before starting the adjustment, wait for more than an hour after switch off for cooling, and perform the adjustment within one minute after switching on.

**Procedure :**

1. Set main volume to minimum position.
2. Switch on the set.
3. Adjust RV500 (RV600 for left channel) so that the voltage across TP500 and TP600 becomes the value indicated below.

**Adjustment values :**

$2.5\text{mV} \pm 0.3\text{mV}$

# SECTION 3 DIAGRAMS

## 3-1. CIRCUIT BOARDS LOCATION

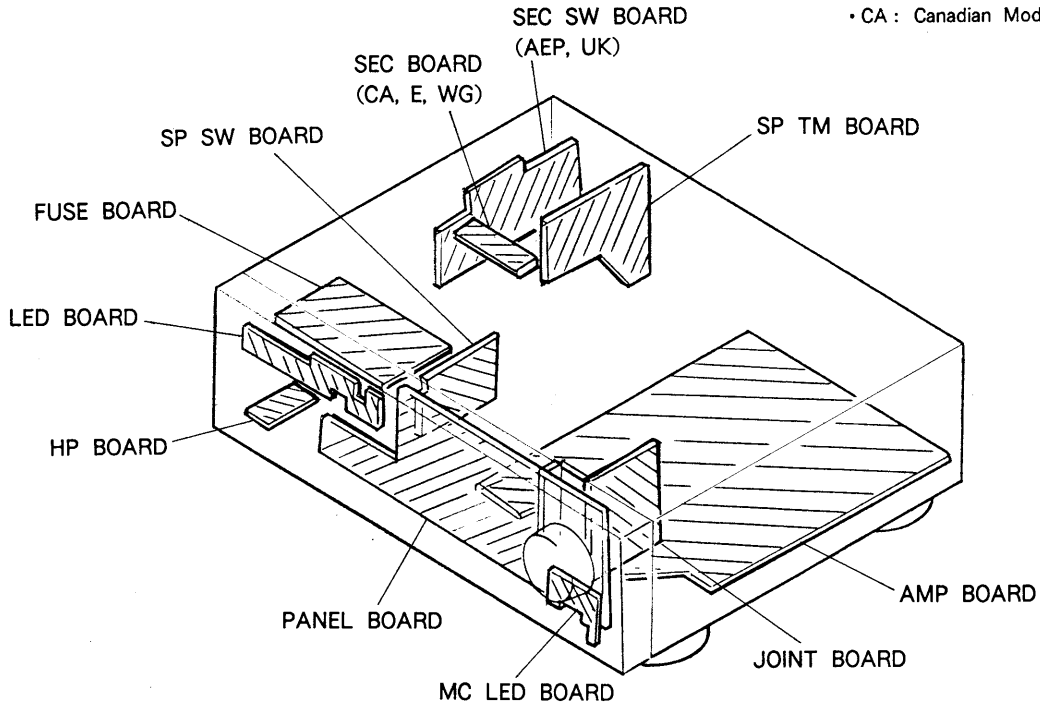

- WG : West Germany Model
- CA : Canadian Model

## 3-2. SEMICONDUCTOR LEAD LAYOUTS

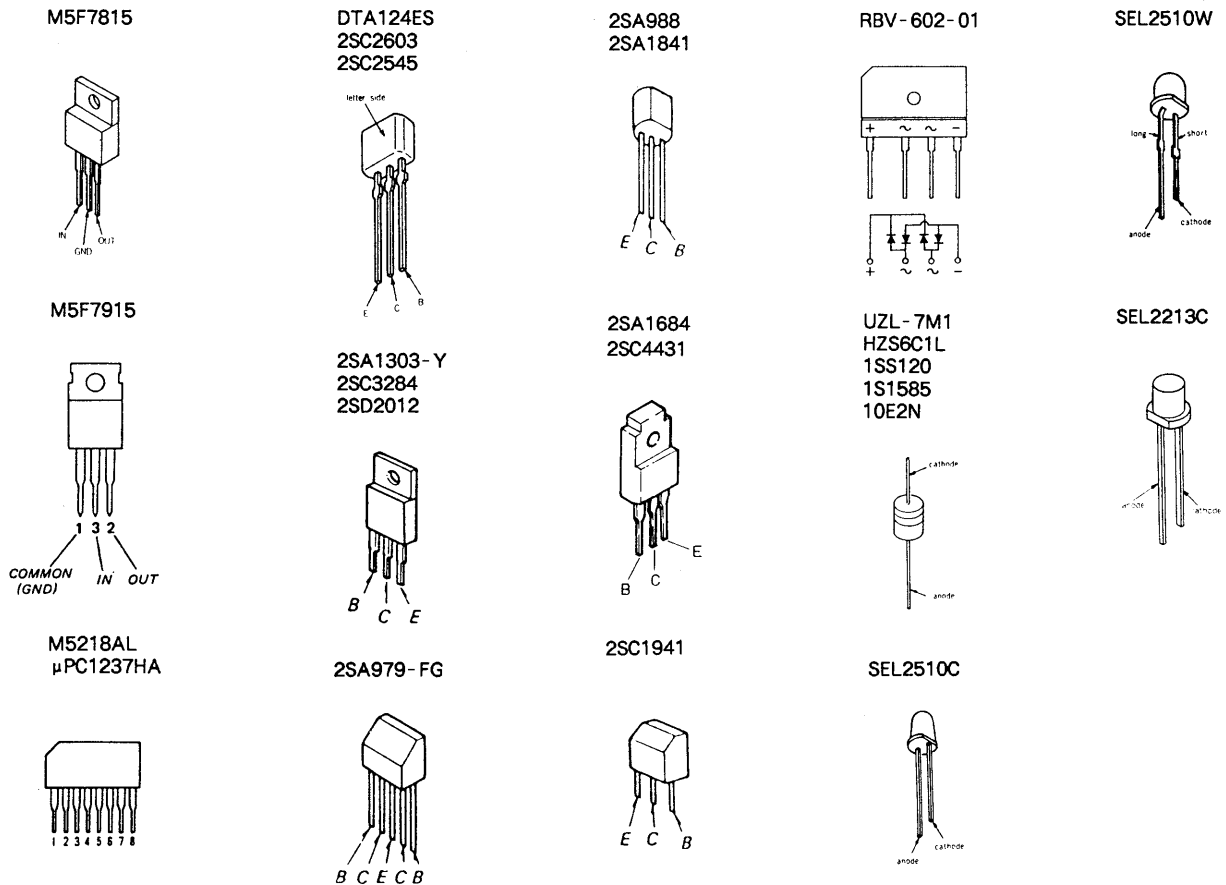



3-3. PRINTED WIRING BOARDS

• Semiconductor Location

Ref. No.	Location	Ref. No.	Location
D150	K-6	IC901	G-6
D151	A-12		
D500	E-5	Q101	K-4
D501	E-3	Q102	J-4
D502	E-5	Q201	I-4
D503	E-3	Q202	I-4
D504	E-3	Q500	F-3
D505	D-5	Q501	F-11
D506	D-5	Q502	F-4
D600	D-11	Q503	E-4
D601	E-10	Q504	E-5
D602	E-11	Q505	E-4
D603	E-9	Q506	E-3
D604	D-11	Q507	B-4
D605	D-11	Q508	D-3
D606	D-11	Q509	D-4
D800	G-10	Q510	D-3
D801	G-9	Q511	D-4
D802	G-10	Q512	B-3
D900	D-6	Q513	B-5
D901	D-6	Q514	D-5
D902	D-6	Q600	F-10
D903	D-6	Q601	E-4
D904	F-7	Q602	F-11
D905	I-23	Q603	F-11
D906	I-22	Q604	E-11
D907	I-23	Q605	E-11
D908	I-23	Q606	D-10
D950	D-16	Q607	B-10
D951	D-16	Q608	D-9
D952	A-29	Q609	D-11
D953	B-28	Q610	D-9
D954	A-28	Q611	D-11
D955A	A-23	Q612	B-9
D955	A-28	Q613	B-11
D956	A-23	Q614	D-11
		Q800	G-11
IC100	J-5	Q901	F-7
IC300	C-23	Q902	E-5
IC301	C-22	Q950	H-11
IC800	G-10	Q951	A-22
IC900	G-7	Q952	A-23

Note:  
 • ○ : parts extracted from the component side.  
 • WG : West Germany Model  
 • CA : Canadian Model

*	AEP, UK E. CA	WB
C101-107	NO	MOUNT
C201-207	NO	MOUNT
R102, 202	JUMPER	MOUNT
R104-107	WIRE	
R204-207	WIRE	
R108, 208	JUMPER	MOUNT
R109, 209	WIRE	

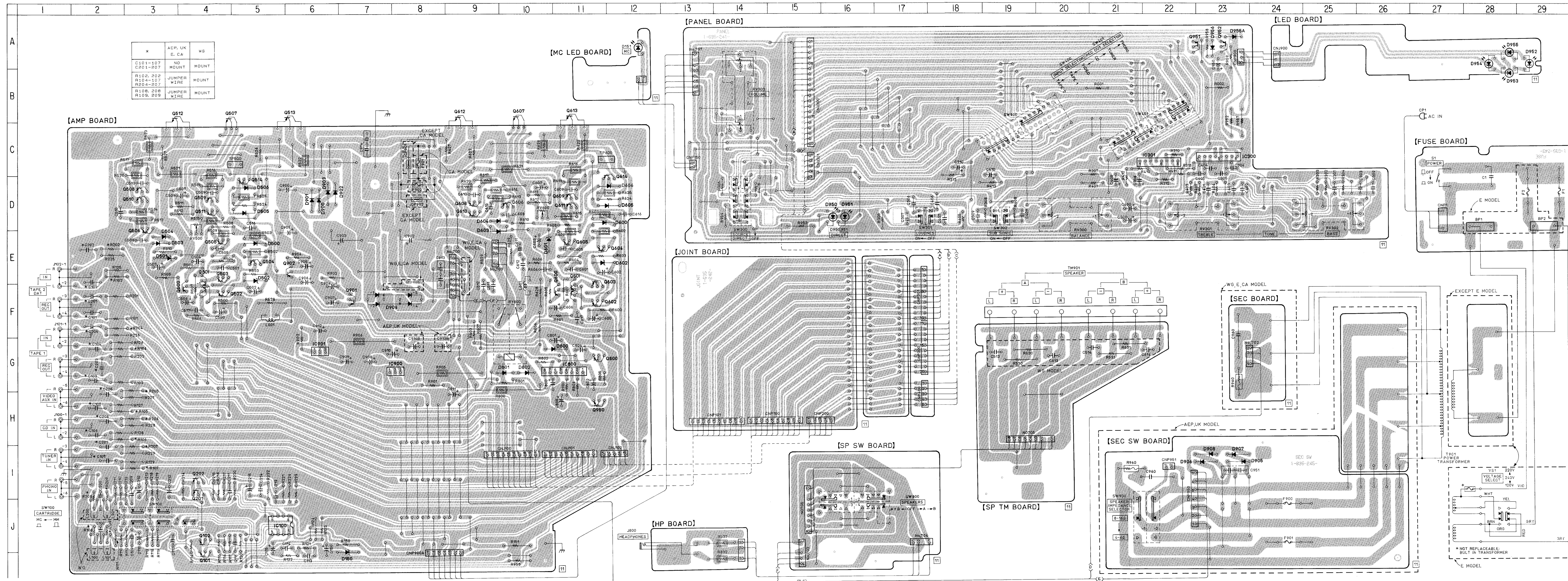



3-4. SCHEMATIC DIAGRAM

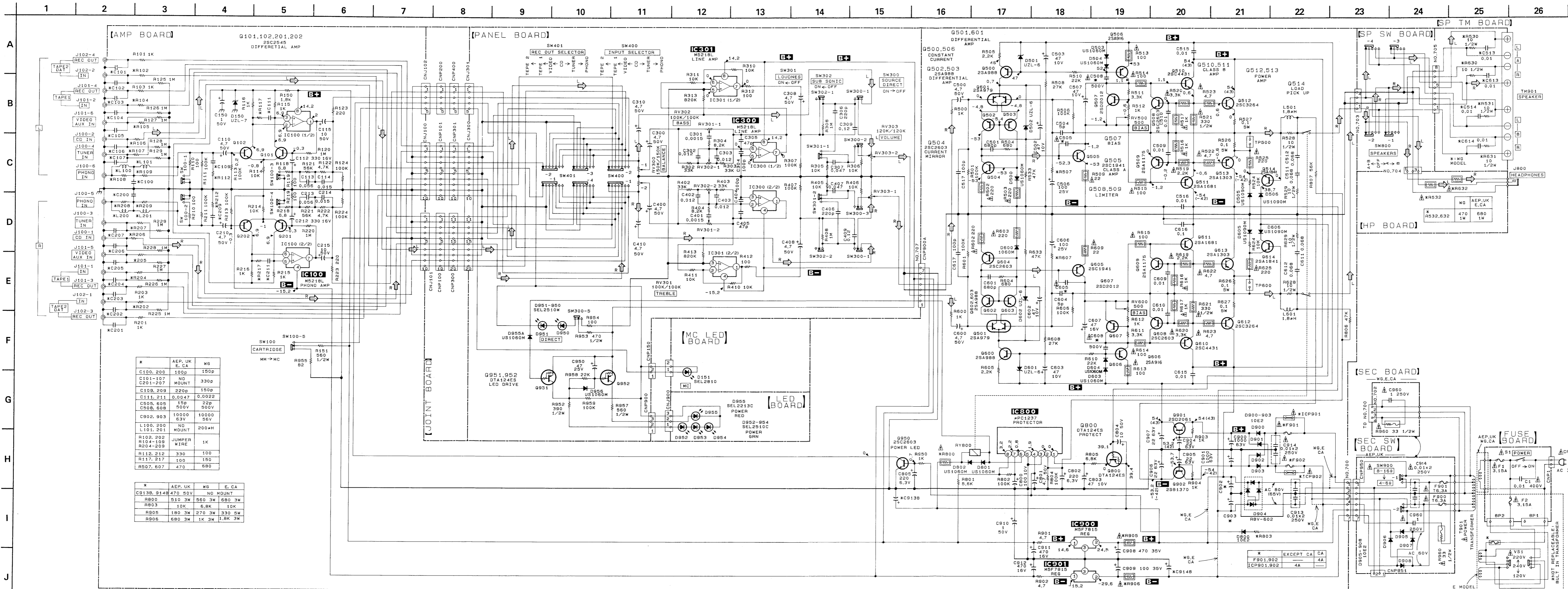

*	AEP, UK	WG	E, CA
C100, 200	100p	150p	
C101-107	NO MOUNT	330p	
C201-207			
C109, 209	220p	150p	
C111, 211	0.0047	0.0022	
C505, 605	15p	22p	
C508, 608	500V	500V	
C902, 903	10000	10000	
L100, 200	NO MOUNT	200μH	
L101, 201			
R102, 202	JUMPER WIRE	1K	
R104-109			
R204-209			
R112, 212	330	100	
R117, 217	100	150	
R507, 607	470	680	

*	AEP, UK	WG	E, CA
C913b, 914b	470 50V	NO MOUNT	
R800	510 3W	560 3W	680 3W
R803	10K	6.8K	10K
R905	180 3W	270 3W	330 5W
R906	680 3W	1K 3W	1.8K 3W

3-5. IC BLOCK DIAGRAM

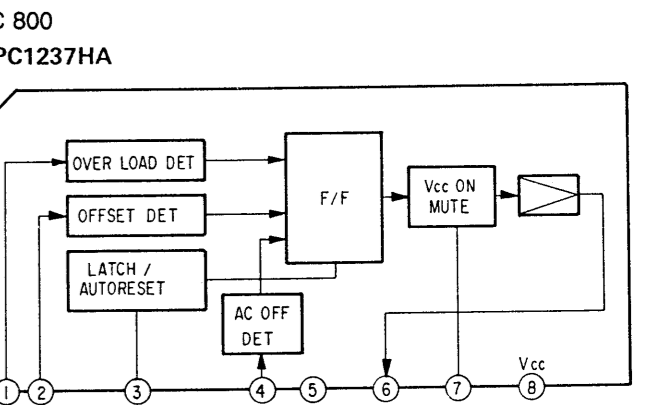

**Note on Schematic Diagram:**

- All capacitors are in  $\mu\text{F}$  unless otherwise noted.  $\text{pF}$ :  $\mu\text{F}$  50VW or less are not indicated except for electrolytics and tantalums.
- All resistors are in  $\Omega$  and  $1/4\text{W}$  or less unless otherwise specified.
- $\square$ : nonflammable resistor.
- $\text{---}/\text{---}$ : fusible resistor.

**Note:** The components identified by mark  $\Delta$  or dotted line with mark  $\Delta$  are critical for safety. Replace only with part number specified.

**Note:** Les composants identifiés par une marque  $\Delta$  sont critiques pour la sécurité. Ne les remplacer que par une pièce portant le numéro spécifié.

- B+**: B+ Line
- B-**: B- Line
- $\text{---}$ : adjustment for repair.
- Voltage and waveforms are dc with respect to ground under no-signal conditions.
- ( ) : West Germany, E. Canadian Model
- ( ) : West Germany, E. Canadian Model
- Voltages are taken with a VOM (impedance 10M  $\Omega$ )
- Voltage variations may be noted due to normal production tolerances.
- Signal path.
- $\text{---}$ : CD
- WG: West Germany Model
- CA: Canadian Model



## SECTION 4 EXPLODED VIEWS

**NOTE:**

- The mechanical parts with no reference number in the exploded views are not supplied.
- The construction parts of an assembled part are indicated with a collation number in the remark column.
- Items marked "\*" are not stocked since they are seldom required for routine service. Some delay should be anticipated when ordering these items.

- Due to standardization, parts with part number suffix -XX and -X may be different from the parts specified in the components used on the set.
- Color Indication of Appearance Parts  
Example:  
(RED) ... KNOB, BALANCE (WHITE)  
↑ Cabinet's Color                      ↑ Parts' Color
- WG : West Germany Model

The components identified by mark or dotted line with mark are critical for safety. Replace only with part number specified.

Les composants identifiés par une marque sont critiques pour la sécurité. Ne les remplacer que par une pièce portant le numéro spécifié.

### 4-1. CASE ,PANEL

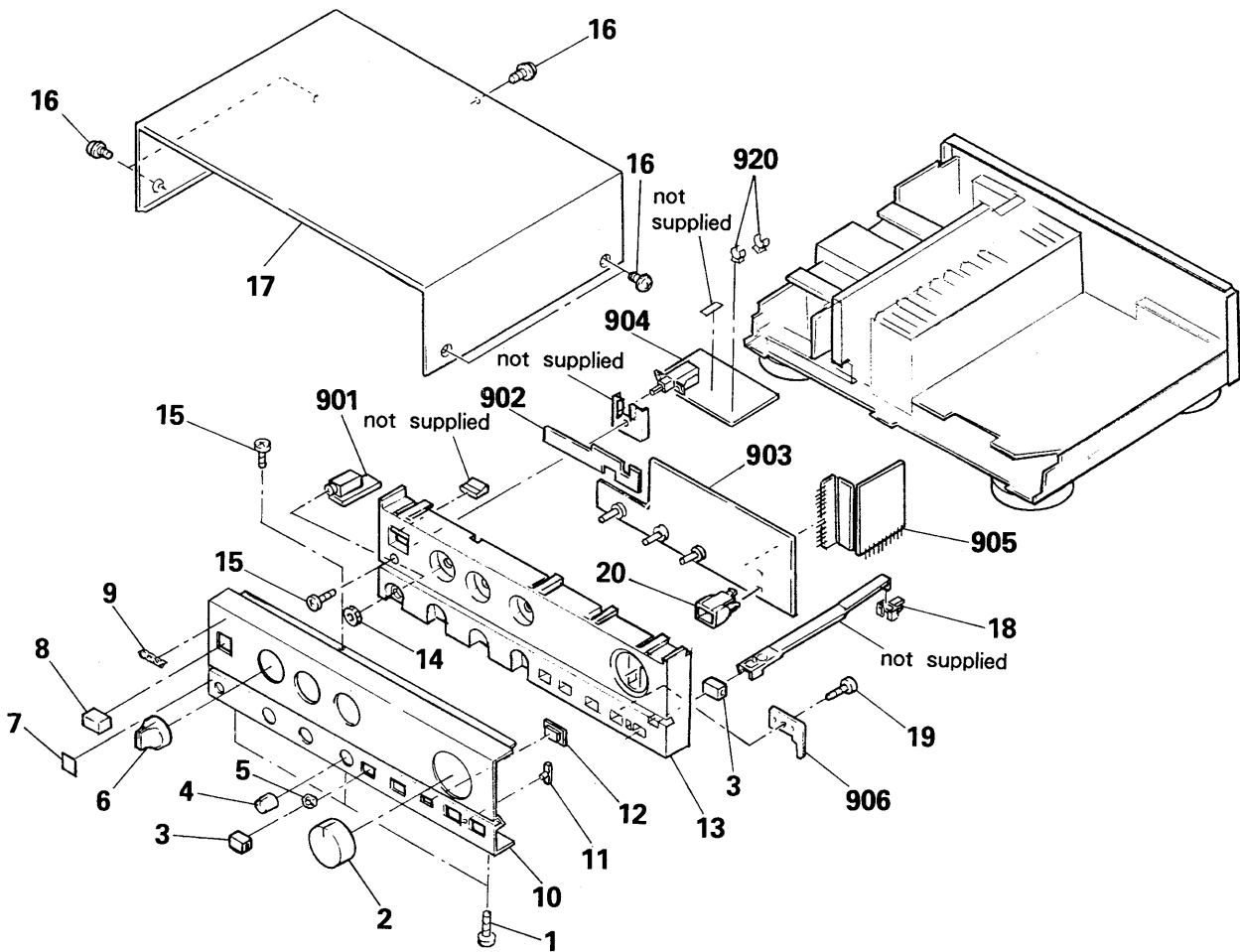

No.	Part No.	Description	Remarks	No.	Part No.	Description	Remarks
1	3-703-685-21	SCREW (+BV 3X8)		17	*4-924-920-71	(WG,Canadian,E)...CASE	
2	4-929-299-01	KNOB (47)			4-927-838-01	(AEP,UK).....CASE	
3	4-908-875-01	KNOB, SQUARE		18	4-866-342-00	JOINT (B), KNOB	
4	4-916-746-11	KNOB (DIA. 21), ROUND		19	7-685-646-79	SCREW +BVTP 3X8 TYPE2 N-S	
5	4-864-307-00	RING		20	*4-921-389-01	HOUSE	
6	4-916-729-01	KNOB (DIA.29)		901	*1-635-237-11	PC BOARD, HP	
7	*3-703-710-41	STICKER, SONY SYMBOL (12)		902	*1-635-239-11	PC BOARD, LED	
8	4-929-289-01	BUTTON		903	*A-4334-714-A	(AEP,UK,E,Canadian)...MOUNTED PCB, PANEL	
9	4-908-848-01	EMBLEM, SONY			*A-4334-725-A	(WG).....MOUNTED PCB, PANEL	
10	4-929-293-32	PANEL, FRONT		904	*1-635-243-11	PC BOARD, FUSE	
11	3-684-018-01	COVER, LAMP, REC		905	*1-635-242-11	PC BOARD, JOINT	
12	4-929-284-01	PLATE, INDICATION		906	*1-635-238-11	PC BOARD, MC LED	
13	4-929-295-13	PANEL (BASE)		920	1-533-213-31	HOLDER, FUSE	
14	4-931-902-01	NUT (M12X1)					
15	7-682-548-04	SCREW +BVTT 3X8 (S)					
16	3-704-366-01	SCREW (CASE) (M3X8)					

4-2. CHASSIS, BACK PANEL

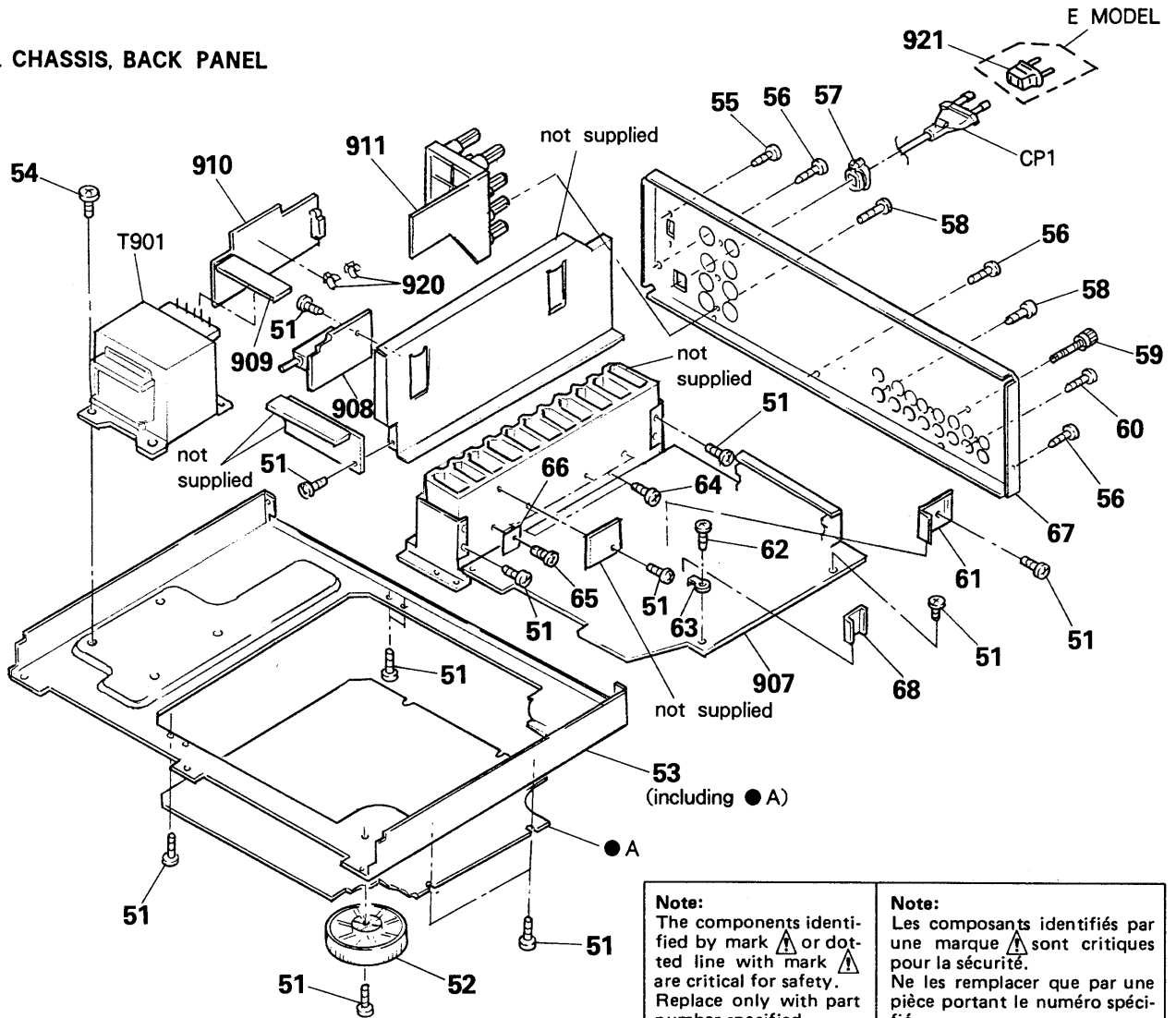

<p><b>Note:</b> The components identified by mark <math>\triangle</math> or dotted line with mark <math>\triangle</math> are critical for safety. Replace only with part number specified.</p>	<p><b>Note:</b> Les composants identifiés par une marque <math>\triangle</math> sont critiques pour la sécurité. Ne les remplacer que par une pièce portant le numéro spécifié.</p>
--	---

No.	Part No.	Description	Remarks	No.	Part No.	Description	Remarks
51	7-682-548-04	SCREW +BVTT 3X8 (S)		67	*4-931-984-11	(AEP).....PANEL, BACK	
52	X-3304-938-2	(WG,AEP,UK).....FOOT ASSY			*4-931-984-21	(WG).....PANEL, BACK	
	X-3304-950-1	(Canadian,E).....FOOT ASSY			*4-931-984-31	(Canadian)...PANEL, BACK	
53	*4-931-618-22	CHASSIS			*4-931-984-41	(E).....PANEL, BACK	
54	7-682-560-04	SCREW +BVTT 4X6 (S)			*4-931-984-51	(UK).....PANEL, BACK	
55	7-685-534-19	(E).....SCREW +BVTP 3X8		68	*3-309-144-21	HEAT SINK	
	7-685-646-79	(AEP,UK)...SCREW +BTP 2.6X8		907	*A-4334-708-A	(AEP,UK)....MOUNTED PCB, AMP	
56	7-682-548-09	SCREW +BVTT 3X8 (S)			*A-4334-719-A	(Canadian)...MOUNTED PCB, AMP	
57	*3-703-244-00	(AEP,UK,WG,Canadian)			*A-4334-721-A	(WG).....MOUNTED PCB, AMP	
		...BUSHING (2104), CORD			*A-4334-727-A	(E).....MOUNTED PCB, AMP	
	*3-703-571-11	(E).....BUSHING (S), CORD		908	*1-635-236-11	PC BOARD, SP SW	
58	7-621-849-00	SCREW, TAPPING		909	*1-635-240-11	(WG,E,Canadian)...PC BOARD, SEC	
59	3-706-165-00	SCREW		910	*1-635-245-11	(AEP,UK)...PC BOARD, SEC SW	
60	7-685-646-79	SCREW +BVTP 3X8		911	*1-635-235-11	PC BOARD, SP TM	
61	*4-931-903-11	HEAT SINK (DI)		920	1-533-213-31	HOLDER, FUSE	
62	3-703-685-21	SCREW (+BV 3X8)		921	$\triangle$ .1-569-007-11	(E)...ADAPTOR, CONVERSION 2P	
63	4-870-539-00	PLATE, GROUND		CP1	$\triangle$ .1-575-105-11	(Canadian)...CORD, POWER	
64	7-682-549-09	SCREW +B 3X10		CP1	$\triangle$ .1-575-651-11	(AEP,WG)....CORD, POWER	
65	7-682-550-09	SCREW +B 3X12		CP1	$\triangle$ .1-575-652-11	(UK).....CORD, POWER	
66	4-911-232-01	SHEET, INSULATING		CP1	$\triangle$ .1-575-653-11	(E).....CORD, POWER	
				T901	$\triangle$ .1-450-092-11	(AE).....TRANSFORMER, POWER	
				T901	$\triangle$ .1-450-093-11	(Canadian)...TRANSFORMER, POWER	
				T901	$\triangle$ .1-450-094-11	(WG).....TRANSFORMER, POWER	
				T901	$\triangle$ .1-450-095-11	(E).....TRANSFORMER, POWER	
				T901	$\triangle$ .1-450-096-11	(UK).....TRANSFORMER, POWER	

## SECTION 5

### ELECTRICAL PARTS LIST

**NOTE:**

- Due to standardization, replacements in the parts list may be different from the parts specified in the diagrams or the components used on the set.
- Items marked "★" are not stocked since they are seldom required for routine service. Some delay should be anticipated when ordering these items.
- If there are two or more same circuits in a set such as a stereophonic machine, only typical circuit parts may be indicated and capacitors and resistors in other same circuits may be omitted.

**CAPACITORS:**

MF:  $\mu$ F, PF:  $\mu$ PF.

**RESISTORS**

- All resistors are in ohms.
- F: nonflammable

**COILS**

- MMH: mH, UH:  $\mu$ H

**SEMICONDUCTORS**

In each case, U:  $\mu$ , for example:

UA...:  $\mu$ A..., UPA...:  $\mu$ PA...,

UPC...:  $\mu$ PC, UPD...:  $\mu$ PD...

The components identified by mark  $\Delta$  or dotted line with mark  $\Delta$  are critical for safety. Replace only with part number specified.

Les composants identifiés par une marque  $\Delta$  sont critiques pour la sécurité. Ne les remplacer que par une pièce portant le numéro spécifié.

• WG : West Germany Model

Ref.No.	Part No.	Description	Ref.No.	Part No.	Description
901	*1-635-237-11	PC BOARD, HP	C201	1-162-288-31	(WG)...CERAMIC 330PF 10% 50V
902	*1-635-239-11	PC BOARD, LED	C202	1-162-288-31	(WG)...CERAMIC 330PF 10% 50V
903	*A-4334-714-A	(AEP,UK,E,Canadian)..MOUNTED PCB, PANEL	C203	1-162-288-31	(WG)...CERAMIC 330PF 10% 50V
	*A-4334-725-A	(WG).....MOUNTED PCB, PANEL	C204	1-162-288-31	(WG)...CERAMIC 330PF 10% 50V
904	*1-635-243-11	PC BOARD, FUSE	C205	1-162-288-31	(WG)...CERAMIC 330PF 10% 50V
905	*1-635-242-11	PC BOARD, JOINT	C206	1-162-288-31	(WG)...CERAMIC 330PF 10% 50V
906	*1-635-238-11	PC BOARD, MC LED	C207	1-162-288-31	(WG)...CERAMIC 330PF 10% 50V
907	*A-4334-708-A	(AEP,UK).....MOUNTED PCB, AMP	C209	1-162-284-31	(WG)...CERAMIC 150PF 10% 50V
	*A-4334-719-A	(Canadian)...MOUNTED PCB, AMP	C209	1-162-286-31	(AEP,UK,E,Canadian) ...CERAMIC 220PF 10% 50V
	*A-4334-721-A	(WG).....MOUNTED PCB, AMP	C210	1-123-369-00	ELECT 4.7MF 20% 50V
	*A-4334-727-A	(E).....MOUNTED PCB, AMP	C211	1-161-375-00	(WG)...CERAMIC 0.0022MF 30% 16V
908	*1-635-236-11	PC BOARD, SP SW	C211	1-161-377-00	(AEP,UK,E,Canadian) ...CERAMIC 0.0047MF 30% 16V
909	*1-635-240-11	(WG,E,Canadian)...PC BOARD, SEC	C212	1-126-541-11	ELECT 330MF 20% 16V
910	*1-635-245-11	(AEP,UK)...PC BOARD, SEC SW	C213	1-130-492-11	MYLAR 0.056MF 5% 50V
911	*1-635-235-11	PC BOARD, SP TM	C214	1-130-485-00	MYLAR 0.015MF 5% 50V
920	1-533-213-31	HOLDER. FUSE	C215	1-126-059-11	ELECT 10MF 20% 50V
921	$\Delta$ .1-569-007-11	(E)...ADAPTOR, CONVERSION 2P	C300	1-123-369-00	ELECT 4.7MF 20% 50V
BP1	1-535-139-00	(E)...BASE POST 22MM	C301	1-106-347-00	MYLAR 0.0015MF 5% 50V
BP2	1-535-139-00	(E)...BASE POST 22MM	C302	1-130-484-00	MYLAR 0.012MF 5% 50V
C1	$\Delta$ .1-161-744-00	CERAMIC 0.01MF 400V	C303	1-130-484-00	MYLAR 0.012MF 5% 50V
C100	1-162-284-31	(WG)...CERAMIC 150PF 10% 50V	C304	1-164-070-11	CERAMIC 100PF 5% 50V
C100	1-162-282-31	(AEP,UK,E,Canadian) ...CERAMIC 100PF 10% 50V	C305	1-164-062-11	CERAMIC 47PF 5% 50V
C101	1-162-288-31	(WG)...CERAMIC 330PF 10% 50V	C306	1-162-286-31	CERAMIC 220PF 10% 50V
C102	1-162-288-31	(WG)...CERAMIC 330PF 10% 50V	C307	1-130-491-00	MYLAR 0.047MF 5% 50V
C103	1-162-288-31	(WG)...CERAMIC 330PF 10% 50V	C308	1-123-369-00	ELECT 4.7MF 20% 50V
C104	1-162-288-31	(WG)...CERAMIC 330PF 10% 50V	C309	1-130-496-00	MYLAR 0.12MF 5% 50V
C105	1-162-288-31	(WG)...CERAMIC 330PF 10% 50V	C310	1-123-369-00	ELECT 4.7MF 20% 50V
C106	1-162-288-31	(WG)...CERAMIC 330PF 10% 50V	C400	1-123-369-00	ELECT 4.7MF 20% 50V
C107	1-162-288-31	(WG)...CERAMIC 330PF 10% 50V	C401	1-106-347-00	MYLAR 0.0015MF 5% 50V
C109	1-162-284-31	(WG)...CERAMIC 150PF 10% 50V	C402	1-130-484-00	MYLAR 0.012MF 5% 50V
C109	1-162-286-31	(AEP,UK,E,Canadian) ...CERAMIC 220PF 10% 50V	C403	1-130-484-00	MYLAR 0.012MF 5% 50V
C110	1-123-369-00	ELECT 4.7MF 20% 50V	C404	1-164-070-11	CERAMIC 100PF 5% 50V
C111	1-161-375-00	(WG)...CERAMIC 0.0022MF 30% 16V	C405	1-164-062-11	CERAMIC 47PF 5% 50V
C111	1-161-377-00	(AEP,UK,E,Canadian) ...CERAMIC 0.0047MF 30% 16V	C406	1-162-286-31	CERAMIC 220PF 10% 50V
C112	1-126-541-11	ELECT 330MF 20% 16V	C407	1-130-491-00	MYLAR 0.047MF 5% 50V
C113	1-130-492-11	MYLAR 0.056MF 5% 50V	C408	1-123-369-00	ELECT 4.7MF 20% 50V
C114	1-130-485-00	MYLAR 0.015MF 5% 50V	C409	1-130-496-00	MYLAR 0.12MF 5% 50V
C115	1-126-059-11	ELECT 10MF 20% 50V	C410	1-123-369-00	ELECT 4.7MF 20% 50V
C150	1-123-380-00	ELECT 1MF 20% 50V	C500	1-123-369-00	ELECT 4.7MF 20% 50V
C200	1-162-284-31	(WG)...CERAMIC 150PF 10% 50V	C501	1-164-083-11	CERAMIC 680PF 10% 50V
C200	1-162-282-31	(AEP,UK,E,Canadian) ...CERAMIC 100PF 10% 50V	C502	1-124-446-11	ELECT 47MF 20% 10V
			C503	1-124-446-11	ELECT 47MF 20% 10V
			C504	1-164-041-11	CERAMIC 5PF 0.25PF 50V

Ref.No.	Part No.	Description			
C505	△.1-161-959-00	(WG)...CERAMIC	22PF	10%	500V
C505	△.1-102-316-00	(AEP,UK,E,Canadian) ...ELECT	15PF	5%	500V
C506	1-123-333-00	ELECT	100MF	20%	25V
C507	1-123-332-00	ELECT	47MF	20%	16V
C508	△.1-161-959-00	(WG)...CERAMIC	22PF	10%	500V
C509	1-130-483-00	MYLAR	0.01MF	5%	50V
C510	1-130-483-00	MYLAR	0.01MF	5%	50V
C511	1-130-493-00	MYLAR	0.068MF	5%	50V
C512	1-130-493-00	MYLAR	0.068MF	5%	50V
C513	1-130-483-00	(WG)...MYLAR	0.01MF	5%	50V
C514	1-130-483-00	(WG)...MYLAR	0.01MF	5%	50V
C515	1-130-483-00	MYLAR	0.01MF	5%	50V
C516	1-130-483-00	MYLAR	0.01MF	5%	50V
C517	1-164-073-11	CERAMIC	100PF	10%	50V
C600	1-123-369-00	ELECT	4.7MF	20%	50V
C601	1-164-083-11	CERAMIC	680PF	10%	50V
C602	1-124-446-11	ELECT	47MF	20%	10V
C603	1-124-446-11	ELECT	47MF	20%	10V
C604	1-164-041-11	CERAMIC	5PF	0.25PF	50V
C605	△.1-161-959-00	(WG)...CERAMIC	22PF	10%	500V
C605	△.1-102-316-00	(AEP,UK,E,Canadian) ...ELECT	15PF	5%	500V
C606	1-123-333-00	ELECT	100MF	20%	25V
C607	1-123-332-00	ELECT	47MF	20%	16V
C608	△.1-161-959-00	(WG)...CERAMIC	22PF	10%	500V
C609	1-130-483-00	MYLAR	0.01MF	5%	50V
C610	1-130-483-00	MYLAR	0.01MF	5%	50V
C611	1-130-493-00	MYLAR	0.068MF	5%	50V
C612	1-130-493-00	MYLAR	0.068MF	5%	50V
C613	1-130-483-00	(WG)...MYLAR	0.01MF	5%	50V
C614	1-130-483-00	(WG)...MYLAR	0.01MF	5%	50V
C615	1-130-483-00	MYLAR	0.01MF	5%	50V
C616	1-130-483-00	MYLAR	0.01MF	5%	50V
C617	1-164-073-11	CERAMIC	100PF	10%	50V
C800	1-124-443-00	ELECT	100MF	20%	10V
C801	1-124-927-11	ELECT	4.7MF	20%	50V
C802	1-126-176-11	ELECT	220MF	20%	6.3V
C803	1-124-446-11	ELECT	47MF	20%	10V
C804	1-123-875-11	ELECT	10MF	20%	50V
C805	1-126-176-11	ELECT	220MF	20%	6.3V
C900	1-124-922-11	ELECT	1000MF	20%	63V
C901	1-124-922-11	ELECT	1000MF	20%	63V
C902	1-125-596-11	(WG)...ELECT(BLOCK)	10000MF	20%	56V
C902	1-125-479-11	(AEP,UK,E,Canadian) ...ELECT	10000MF	20%	63V
C903	1-125-596-11	(WG)...ELECT(BLOCK)	10000MF	20%	56V
C903	1-125-479-11	(AEP,UK,E,Canadian) ...ELECT	10000MF	20%	63V
C904	1-124-929-11	ELECT	22MF	20%	63V
C905	1-124-929-11	ELECT	22MF	20%	63V
C906	1-124-929-11	ELECT	22MF	20%	63V
C907	1-124-929-11	ELECT	22MF	20%	63V
C908	1-126-104-11	ELECT	470MF	20%	35V
C909	1-126-052-11	ELECT	100MF	20%	35V

Ref.No.	Part No.	Description			
C910	1-126-044-11	ELECT	1MF	20%	50V
C911	1-126-103-11	ELECT	470MF	20%	16V
C912	1-126-103-11	ELECT	470MF	20%	16V
C913A	△.1-102-394-11	CERAMIC	0.01MF		250V
C913B	1-124-913-11	(AEP,UK)...ELECT	470MF	20%	50V
C914A	△.1-102-394-11	CERAMIC	0.01MF		250V
C914B	1-124-913-11	(AEP,UK)...ELECT	470MF	20%	50V
C950	1-124-477-11	ELECT	47MF	20%	25V
C951	△.1-102-394-11	(AEP,UK)...CERAMIC	0.01MF		250V
C960	△.1-130-798-00	FILM	1MF	10%	250V
CNJ300	1-565-961-11	SOCKET, CONNECTOR	20P		
CNJ301*	1-561-650-00	SOCKET, CONNECTOR	5P		
CNJ900*	1-565-835-11	SOCKET, CONNECTOR	3P		
CNP1	*1-564-321-00	PIN, CONNECTOR	2P		
CNP100	1-565-419-11	PIN, CONNECTOR	10P		
CNP101	1-565-419-11	PIN, CONNECTOR	10P		
CNP150*	1-564-336-00	PIN, CONNECTOR	2P		
CNP200	1-506-906-11	PIN, CONNECTOR	5P		
CNP300	1-565-419-11	PIN, CONNECTOR	10P		
CNP301	1-565-419-11	PIN, CONNECTOR	10P		
CNP400	1-506-906-11	PIN, CONNECTOR	5P		
CNP900*	1-564-510-11	PLUG, CONNECTOR	7P		
CNP900A1	1-568-577-11	PIN, CONNECTOR (PC BOARD)	3P		
CNP950*	1-564-915-11	(AEP,UK)...PIN, CONNECTOR	7P		
CNP951*	1-564-517-11	(AEP,UK)...PIN, CONNECTOR	2P		
CP1	△.1-575-105-11	(Canadian)...CORD, POWER			
CP1	△.1-575-651-11	(AEP,UK)...CORD, POWER			
CP1	△.1-575-652-11	(UK)...CORD, POWER			
CP1	△.1-575-653-11	(E)...CORD, POWER			
D150	8-719-000-84	DIODE UZL-7M1			
D151	8-719-311-61	DIODE SEL2810D-D			
D500	8-719-912-20	DIODE 1SS120			
D501	8-719-933-39	DIODE HZS6C1L			
D502	8-719-933-39	DIODE HZS6C1L			
D503	8-719-912-20	DIODE 1SS120			
D504	8-719-912-20	DIODE 1SS120			
D505	8-719-815-85	DIODE 1S1585			
D506	8-719-815-85	DIODE 1S1585			
D600	8-719-912-20	DIODE 1SS120			
D601	8-719-933-39	DIODE HZS6C1L			
D602	8-719-933-39	DIODE HZS6C1L			
D603	8-719-912-20	DIODE 1SS120			
D604	8-719-912-20	DIODE 1SS120			
D605	8-719-815-85	DIODE 1S1585			
D606	8-719-815-85	DIODE 1S1585			
D800	8-719-200-77	DIODE 10E2N			
D801	8-719-912-20	DIODE 1SS120			
D802	8-719-912-20	DIODE 1SS120			
D900	8-719-200-77	DIODE 10E2N			
D901	8-719-200-77	DIODE 10E2N			
D902	8-719-200-77	DIODE 10E2N			
D903	8-719-200-77	DIODE 10E2N			
D904	△.8-719-302-38	DIODE RBV-602-01			
D905	8-719-200-77	(AEP,UK)...DIODE 10E2N			
D906	8-719-200-77	(AEP,UK)...DIODE 10E2N			
D907	8-719-200-77	(AEP,UK)...DIODE 10E2N			
D908	8-719-200-77	(AEP,UK)...DIODE 10E2N			

**Note:**  
The components identified by mark △ or dotted line with mark △ are critical for safety. Replace only with part number specified.

**Note:**  
Les composants identifiés par une marque △ sont critiques pour la sécurité. Ne les remplacer que par une pièce portant le numéro spécifié.



Ref.No.	Part No.	Description
D950	8-719-304-16	LED SEL2510W-D
D951	8-719-304-16	LED SEL2510W-D
D952	8-719-304-16	LED SEL2510W-D
D953	8-719-304-16	LED SEL2510W-D
D954	8-719-304-16	LED SEL2510W-D
D955A	8-719-912-20	DIODE 1SS120
D955	8-719-302-23	LED SEL2213C-C
D956	8-719-912-20	DIODE 1SS120
F1	▲.1-532-237-00	(AEP,UK,WG)...FUSE, TIME LAG (3.15A)
F1	▲.1-532-747-11	(Canadian)...FUSE, GLASS TUBE
F2	▲.1-532-237-00	(E).....FUSE, TIME LAG (3.15A)
F900	▲.1-532-506-51	(AEP,UK)...FUSE, TIME LAG (6.3A)
F901A	▲.1-532-506-51	(AEP,UK)...FUSE, TIME LAG (6.3A)
F901	▲.1-532-782-11	(Canadian)...FUSE, MICRO (4A)
F902	▲.1-532-782-11	(Canadian)...FUSE, MICRO (4A)
IC100	8-759-981-98	IC RC4560DD
IC300	8-759-634-50	IC M5218AL
IC301	8-759-634-50	IC M5218AL
IC800	8-759-111-68	IC UPC1237HA
IC900	8-759-604-34	IC M5F7815
IC901	8-759-604-52	IC M5F7915
ICP901A	▲.1-532-845-21	(AEP,UK,E,WG)...LINK, IC (4A)
ICP902A	▲.1-532-845-21	(AEP,UK,E,WG)...LINK, IC (4A)
J100	1-565-320-11	JACK, PIN 6P
J101	1-565-320-11	JACK, PIN 6P
J102	1-565-258-11	JACK, PIN 4P
J800	1-507-863-51	JACK, LARGE TYPE
L100	1-413-101-11 (WG)...	COIL, INPUT 220UH
L101	1-413-101-11 (WG)...	COIL, INPUT 220UH
L200	1-413-101-11 (WG)...	COIL, INPUT 220UH
L201	1-413-101-11 (WG)...	COIL, INPUT 220UH
L501	*1-420-872-00	COIL, AIR CORE
L601	*1-420-872-00	COIL, AIR CORE
Q101	8-729-354-52	TRANSISTOR 2SC2545-E
Q102	8-729-354-52	TRANSISTOR 2SC2545-E
Q201	8-729-354-52	TRANSISTOR 2SC2545-E
Q202	8-729-354-52	TRANSISTOR 2SC2545-E
Q500	8-729-108-14	TRANSISTOR 2SA988F
Q501	8-729-620-18	TRANSISTOR 2SA979-FG
Q502	8-729-108-14	TRANSISTOR 2SA988F
Q503	8-729-108-14	TRANSISTOR 2SA988F
Q504	8-729-620-05	TRANSISTOR 2SC2603-EF
Q505	8-729-142-01	TRANSISTOR 2SC1941-LK
Q506	8-729-191-62	TRANSISTOR 2SA1371
Q507	8-729-209-15	TRANSISTOR 2SD2012
Q508	8-729-620-05	TRANSISTOR 2SC2603-EF
Q509	8-729-119-76	TRANSISTOR 2SA1175-HFE
Q510	8-729-141-46	TRANSISTOR 2SC4431-LK
Q511	8-729-141-37	TRANSISTOR 2SA1684-LK
Q512	8-729-302-84	TRANSISTOR 2SC3284-Y
Q513	8-729-302-81	TRANSISTOR 2SA1303-Y
Q514	8-729-140-84	TRANSISTOR 2SA1841-PAFAEA
Q600	8-729-108-14	TRANSISTOR 2SA988F
Q601	8-729-620-18	TRANSISTOR 2SA979-FG

Ref.No.	Part No.	Description
Q602	8-729-108-14	TRANSISTOR 2SA988F
Q603	8-729-108-14	TRANSISTOR 2SA988F
Q604	8-729-620-05	TRANSISTOR 2SC2603-EF
Q605	8-729-142-01	TRANSISTOR 2SC1941-LK
Q606	8-729-191-62	TRANSISTOR 2SA1371
Q607	8-729-209-15	TRANSISTOR 2SD2012
Q608	8-729-620-05	TRANSISTOR 2SC2603-EF
Q609	8-729-119-76	TRANSISTOR 2SA1175-HFE
Q610	8-729-141-46	TRANSISTOR 2SC4431-LK
Q611	8-729-141-37	TRANSISTOR 2SA1684-LK
Q612	8-729-302-84	TRANSISTOR 2SC3284-Y
Q613	8-729-302-81	TRANSISTOR 2SA1303-Y
Q614	8-729-140-84	TRANSISTOR 2SA1841-PAFAEA
Q800	8-729-900-63	TRANSISTOR DTA124ES
Q901	8-729-925-69	TRANSISTOR 2SD2061EF
Q902	8-729-924-90	TRANSISTOR 2SB1370-EF
Q950	8-729-620-05	TRANSISTOR 2SC2603-EF
Q951	8-729-900-63	TRANSISTOR DTA124ES
Q952	8-729-900-63	TRANSISTOR DTA124ES
R101	1-247-713-11	CARBON 1K 5% 1/4W
R102	1-247-713-11	(WG)...CARBON 1K 5% 1/4W
R103	1-247-713-11	CARBON 1K 5% 1/4W
R104	1-247-713-11	(WG)...CARBON 1K 5% 1/4W
R105	1-247-713-11	(WG)...CARBON 1K 5% 1/4W
R106	1-247-713-11	(WG)...CARBON 1K 5% 1/4W
R107	1-247-713-11	(WG)...CARBON 1K 5% 1/4W
R108	1-249-417-11	(WG)...CARBON 1K 5% 1/4W
R109	1-249-417-11	(WG)...CARBON 1K 5% 1/4W
R110	1-249-405-11	CARBON 100 5% 1/4W
R111	1-259-476-11	CARBON 100K 5% 1/6W
R112	1-249-405-11	(WG)...CARBON 100 5% 1/4W
R112	1-249-411-11	(AEP,UK,E,Canadian) ...CARBON 330 5% 1/4W
R113	1-259-476-11	CARBON 100K 5% 1/6W
R114	1-259-452-11	CARBON 10K 5% 1/6W
R115	1-249-417-11	CARBON 1K 5% 1/4W
R116	1-249-417-11	CARBON 1K 5% 1/4W
R117	1-249-405-11	(AEP,UK,E,Canadian) ...CARBON 100 5% 1/4W
R117	1-249-407-11	(WG)...CARBON 150 5% 1/4W
R118	1-249-391-11	CARBON 6.8 5% 1/4W
R119	1-249-405-11	CARBON 100 5% 1/4W
R120	1-247-903-00	CARBON 1M 5% 1/4W
R121	1-259-470-11	CARBON 56K 5% 1/6W
R122	1-259-444-11	CARBON 4.7K 5% 1/6W
R123	1-249-409-11	CARBON 220 5% 1/4W
R124	1-259-476-11	CARBON 100K 5% 1/6W
R125	1-246-545-00	CARBON 1M 5% 1/4W
R126	1-246-545-00	CARBON 1M 5% 1/4W
R127	1-246-545-00	CARBON 1M 5% 1/4W
R128	1-246-545-00	CARBON 1M 5% 1/4W
R129	1-246-545-00	CARBON 1M 5% 1/4W
R150	1-247-716-11	CARBON 1.8K 5% 1/4W
R151	1-247-749-11	CARBON 560 5% 1/2W
R201	1-247-713-11	CARBON 1K 5% 1/4W

<p><b>Note:</b> The components identified by mark ▲ or dotted line with mark ▲ are critical for safety. Replace only with part number specified.</p>	<p><b>Note:</b> Les composants identifiés par une marque ▲ sont critiques pour la sécurité. Ne les remplacer que par une pièce portant le numéro spécifié.</p>
--	--

Ref.No.	Part No.	Description				
R202	1-247-713-11	(WG)...CARBON	1K	5%	1/4W	
R203	1-247-713-11	CARBON	1K	5%	1/4W	
R204	1-247-713-11	(WG)...CARBON	1K	5%	1/4W	
R205	1-247-713-11	(WG)...CARBON	1K	5%	1/4W	
R206	1-247-713-11	(WG)...CARBON	1K	5%	1/4W	
R207	1-247-713-11	(WG)...CARBON	1K	5%	1/4W	
R208	1-249-417-11	(WG)...CARBON	1K	5%	1/4W	
R209	1-249-417-11	(WG)...CARBON	1K	5%	1/4W	
R210	1-249-405-11	CARBON	100	5%	1/4W	
R211	1-259-476-11	CARBON	100K	5%	1/6W	
R212	1-249-405-11	(WG)...CARBON	100	5%	1/4W	
R212	1-249-411-11	(AEP,UK,E,Canadian) ...CARBON	330	5%	1/4W	
R213	1-259-476-11	CARBON	100K	5%	1/6W	
R214	1-259-452-11	CARBON	10K	5%	1/6W	
R215	1-249-417-11	CARBON	1K	5%	1/4W	
R216	1-249-417-11	CARBON	1K	5%	1/4W	
R217	1-249-405-11	(AEP,UK,E,Canadian) ...CARBON	100	5%	1/4W	
R217	1-249-407-11	(WG)...CARBON	150	5%	1/4W	
R218	1-249-391-11	CARBON	6.8	5%	1/4W	
R219	1-249-405-11	CARBON	100	5%	1/4W	
R220	1-247-903-00	CARBON	1M	5%	1/4W	
R221	1-259-470-11	CARBON	56K	5%	1/6W	
R222	1-259-444-11	CARBON	4.7K	5%	1/6W	
R223	1-249-409-11	CARBON	220	5%	1/4W	
R224	1-259-476-11	CARBON	100K	5%	1/6W	
R225	1-246-545-00	CARBON	1M	5%	1/4W	
R226	1-246-545-00	CARBON	1M	5%	1/4W	
R227	1-246-545-00	CARBON	1M	5%	1/4W	
R228	1-246-545-00	CARBON	1M	5%	1/4W	
R229	1-246-545-00	CARBON	1M	5%	1/4W	
R302	1-249-435-11	CARBON	33K	5%	1/4W	
R303	1-249-435-11	CARBON	33K	5%	1/4W	
R304	1-249-428-11	CARBON	8.2K	5%	1/4W	
R305	1-249-429-11	CARBON	10K	5%	1/4W	
R306	1-249-429-11	CARBON	10K	5%	1/4W	
R307	1-249-469-11	CARBON	100K	5%	1/4W	
R308	1-247-903-00	CARBON	1M	5%	1/4W	
R310	1-249-429-11	CARBON	10K	5%	1/4W	
R311	1-249-429-11	CARBON	10K	5%	1/4W	
R312	1-249-405-11	CARBON	100	5%	1/4W	
R313	1-249-993-21	CARBON	820K	1%	1/4W	
R402	1-249-435-11	CARBON	33K	5%	1/4W	
R403	1-249-435-11	CARBON	33K	5%	1/4W	
R404	1-249-428-11	CARBON	8.2K	5%	1/4W	
R405	1-249-429-11	CARBON	10K	5%	1/4W	
R406	1-249-429-11	CARBON	10K	5%	1/4W	
R407	1-249-469-11	CARBON	100K	5%	1/4W	
R408	1-247-903-00	CARBON	1M	5%	1/4W	
R410	1-249-429-11	CARBON	10K	5%	1/4W	
R411	1-249-429-11	CARBON	10K	5%	1/4W	
R412	1-249-405-11	CARBON	100	5%	1/4W	
R413	1-249-993-21	CARBON	820K	1%	1/4W	
R500	1-247-713-11	CARBON	1K	5%	1/4W	
R501	1-249-469-11	CARBON	100K	1%	1/4W	

Ref.No.	Part No.	Description				
R502	△.1-247-704-11	CARBON	220	5%	1/4W	F
R503	△.1-247-704-11	CARBON	220	5%	1/4W	F
R504	1-247-711-11	CARBON	680	5%	1/4W	
R505	1-247-717-11	CARBON	2.2K	5%	1/4W	
R506	1-249-469-11	CARBON	100K	1%	1/4W	
R507	1-247-708-11	(AEP,UK,E,Canadian) ...CARBON	470	5%	1/4W	
R507	1-249-919-11	(WG)...CARBON	680	1%	1/4W	
R508	1-249-463-11	CARBON	27K	5%	1/4W	
R509	△.1-247-692-11	CARBON	22	5%	1/4W	F
R510	1-249-462-11	CARBON	22K	5%	1/4W	
R511	1-247-719-11	CARBON	3.3K	5%	1/4W	
R512	1-247-713-11	CARBON	1K	5%	1/4W	
R513	△.1-247-700-11	CARBON	100	5%	1/4W	F
R514	△.1-247-700-11	CARBON	100	5%	1/4W	F
R515	△.1-247-700-11	CARBON	100	5%	1/4W	F
R516	△.1-247-713-11	CARBON	1K	5%	1/4W	F
R517	△.1-247-713-11	CARBON	1K	5%	1/4W	F
R519	△.1-247-717-11	CARBON	2.2K	5%	1/4W	F
R520	△.1-247-719-11	CARBON	3.3K	5%	1/4W	F
R521	△.1-247-745-11	CARBON	330	5%	1/2W	F
R522	△.1-249-455-11	CARBON	4.7	5%	1/4W	F
R523	△.1-249-455-11	CARBON	4.7	5%	1/4W	F
R524	1-247-725-11	CARBON	10K	5%	1/4W	
R525	△.1-247-704-11	CARBON	220	5%	1/4W	F
R526	1-214-789-00	RES, METAL PLATE	0.1			
R527	1-214-789-00	RES, METAL PLATE	0.1			
R528	1-247-727-11	CARBON	10	5%	1/2W	
R529	1-247-727-11	CARBON	10	5%	1/2W	
R530	1-247-727-11	(WG)...CARBON	10	5%	1/2W	
R531	1-247-727-11	(WG)...CARBON	10	5%	1/2W	
R532	△.1-215-867-00	(WG)...METAL OXIDE	470	5%	1W	F
R532	△.1-215-868-00	(AEP,UK,E,Canadian) ...METAL OXIDE	680	5%	1W	
R533	1-249-465-11	CARBON	47K	5%	1/4W	
R600	1-247-713-11	CARBON	1K	5%	1/4W	
R601	1-249-469-11	CARBON	100K	1%	1/4W	
R602	△.1-247-704-11	CARBON	220	5%	1/4W	F
R603	△.1-247-704-11	CARBON	220	5%	1/4W	F
R604	1-247-711-11	CARBON	680	5%	1/4W	
R605	1-247-717-11	CARBON	2.2K	5%	1/4W	
R606	1-249-469-11	CARBON	100K	1%	1/4W	
R607	1-247-708-11	(AEP,UK,E,Canadian) ...CARBON	470	5%	1/4W	
R607	1-249-919-11	(WG)...CARBON	680	1%	1/4W	
R608	1-249-463-11	CARBON	27K	5%	1/4W	
R609	△.1-247-692-11	CARBON	22	5%	1/4W	F
R610	1-249-462-11	CARBON	22K	5%	1/4W	
R611	1-247-719-11	CARBON	3.3K	5%	1/4W	
R612	1-247-713-11	CARBON	1K	5%	1/4W	
R613	△.1-247-700-11	CARBON	100	5%	1/4W	F
R614	△.1-247-700-11	CARBON	100	5%	1/4W	F
R615	△.1-247-700-11	CARBON	100	5%	1/4W	F
R616	△.1-247-713-11	CARBON	1K	5%	1/4W	F

**Note:**  
The components identified by mark △ or dotted line with mark △ are critical for safety. Replace only with part number specified.

**Note:**  
Les composants identifiés par une marque △ sont critiques pour la sécurité. Ne les remplacer que par une pièce portant le numéro spécifié.

Ref.No.	Part No.	Description				
R617	△.1-247-713-11	CARBON	1K	5%	1/4W	F
R619	△.1-247-717-11	CARBON	2.2K	5%	1/4W	F
R620	△.1-247-719-11	CARBON	3.3K	5%	1/4W	F
R621	△.1-247-745-11	CARBON	330	5%	1/2W	F
R622	△.1-249-455-11	CARBON	4.7	5%	1/4W	F
R623	△.1-249-455-11	CARBON	4.7	5%	1/4W	F
R624	1-247-725-11	CARBON	10K	5%	1/4W	
R625	△.1-247-704-11	CARBON	220	5%	1/4W	F
R626	1-214-789-00	RES, METAL PLATE 0.1				
R627	1-214-789-00	RES, METAL PLATE 0.1				
R628	1-247-727-11	CARBON	10	5%	1/2W	
R629	1-247-727-11	CARBON	10	5%	1/2W	
R630	1-247-727-11	(WG)...CARBON	10	5%	1/2W	
R631	1-247-727-11	(WG)...CARBON	10	5%	1/2W	
R632	△.1-215-867-00	(WG)...METAL OXIDE	470	5%	1W	F
R632	△.1-215-868-00	(AEP,UK,E,Canadian) ...METAL OXIDE	680	5%	1W	
R633	1-249-465-11	CARBON	47K	5%	1/4W	
R800	△.1-216-479-11	(WG).....METAL OXIDE	560	5%	3W	F
R800	△.1-206-718-00	(AEP,UK).....METAL OXIDE	510	5%	3W	
R800	△.1-215-916-00	(E,Canadian)...METAL OXIDE	680	5%	3W	
R801	1-249-426-11	CARBON	5.6K	5%	1/4W	
R802	1-249-441-11	CARBON	100K	5%	1/4W	
R803	1-249-427-11	(WG)...CARBON	6.8K	5%	1/4W	
R803	△.1-249-429-11	(AEP,UK,E,Canadian) ...CARBON	10K	5%	1/4W	
R804	1-249-441-11	CARBON	100K	5%	1/4W	
R805	1-249-427-11	CARBON	6.8K	5%	1/4W	
R806	1-249-437-11	CARBON	47K	5%	1/4W	
R807	1-249-438-11	CARBON	56K	5%	1/4W	
R901	1-249-455-11	CARBON	4.7	5%	1/4W	
R902	1-249-455-11	CARBON	4.7	5%	1/4W	
R903	1-247-713-11	CARBON	1K	5%	1/4W	
R904	1-247-713-11	CARBON	1K	5%	1/4W	
R905	△.1-215-939-11	(E,Canadian) ...METAL OXIDE	330	5%	5W	
R905	△.1-216-476-11	(AEP,UK)...METAL OXIDE	180	5%	3W	
R905	△.1-216-477-11	(WG).....METAL OXIDE	270	5%	3W	F
R906	△.1-215-916-11	(AEP,UK)...METAL OXIDE	680	5%	3W	
R906	△.1-215-917-11	(WG).....METAL OXIDE	1K	5%	3W	F
R906	△.1-216-482-11	(E,Canadian) ...METAL OXIDE	1.8K	5%	5W	
R950	1-249-417-11	CARBON	1K	5%	1/4W	
R952	1-247-746-11	CARBON	390	5%	1/2W	
R953	1-247-747-11	CARBON	470	5%	1/2W	

Ref.No.	Part No.	Description				
R954	1-247-700-11	CARBON	100	5%	1/4W	
R955	1-247-699-11	CARBON	82	5%	1/4W	
R957	1-247-749-11	CARBON	560	5%	1/2W	
R958	1-249-433-11	CARBON	22K	5%	1/4W	
R959	1-249-441-11	CARBON	100K	5%	1/4W	
R960	△.1-212-970-00	FUSIBLE	33	5%	1/2W	F
RV300	1-238-513-11	RES, VAR, CARBON 150K/150K (BALANCE)				
RV301	1-241-056-11	RES, VAR, CARBON 100K/100K (TREBLE)				
RV302	1-241-056-11	RES, VAR, CARBON 100K/100K (BASS)				
RV303	1-238-512-11	RES, VAR, CARBON 120K/120K (VOLUME)				
RV500	1-237-455-11	RES, ADJ, CARBON 500 (BIAS)				
RV600	1-237-455-11	RES, ADJ, CARBON 500 (BIAS)				
RY800	1-515-356-00	RELAY				
S1	△.1-554-920-21	SWITCH, PUSH (AC POWER)(1 KEY)				
SW100	1-572-357-11	SWITCH, PUSH (CARTRIDGE)				
SW300	1-571-637-21	SWITCH, PUSH (1 KEY)(SOURCE DIRECT)				
SW301	1-571-112-21	SWITCH, PUSH (1 KEY)(LOUDNESS)				
SW302	1-571-112-21	SWITCH, PUSH (1 KEY)(SUBSONIC)				
SW400	1-571-871-11	SWITCH, ROTARY SLIDDE (INPUT)				
SW401	1-571-871-11	SWITCH, ROTARY SLIDDE (REC OUT)				
SW800	1-571-870-11	SWITCH, ROTARY SLIDDE (SP)				
SW900	△.1-571-309-31	(AEP,UK)...SWITCH				
T901	△.1-450-092-11	(AE).....TRANSFORMER, POWER				
T901	△.1-450-093-11	(Canadian)...TRANSFORMER, POWER				
T901	△.1-450-094-11	(WG).....TRANSFORMER, POWER				
T901	△.1-450-095-11	(E).....TRANSFORMER, POWER				
T901	△.1-450-096-11	(UK).....TRANSFORMER, POWER				
TM901	1-537-227-11	(AEP).....TERMINAL BOARD(SP)				
TM901	1-537-228-11	(WG,UK,E,Canadian)...TERMINAL BOARD(SP)				
TP500	*1-535-115-00	TERMINAL				
TP600	*1-535-115-00	TERMINAL				
VS1	△.1-570-307-11	(E)...SWITCH, VOLTAGE CHANGE				

ACCESSORY & PACKING MATERIAL

3-701-630-00	BAG, POLYETHYLENE
*3-703-710-41	STICKER, SONY SYMBOL (12)
3-751-657-11	(AEP,UK,E,Canadian)...MANUAL, INSTRUCTION
3-751-657-41	(AEP).....MANUAL, INSTRUCTION
3-751-657-51	(US).....MANUAL, INSTRUCTION
*4-931-985-01	CUSHION
*4-931-986-01	INDIVIDUAL CARTON

**Note:**  
The components identified by mark △ or dotted line with mark △ are critical for safety. Replace only with part number specified.

**Note:**  
Les composants identifiés par une marque △ sont critiques pour la sécurité. Ne les remplacer que par une pièce portant le numéro spécifié.





# TA-F420/F420A

## SONY SERVICE MANUAL

*AEP Model  
UK Model*

TA-F420A

*Canadian Model*

*West Germany Model*

*E Model*

TA-F420

## SUPPLEMENT-1

File this supplement with the service manual.

**Subject : 1. Modification on AMP Board**

### 1. Modification on AMP Board

#### • New/Former Distinction

	Former Suffix of board part No. :-11	New Suffix of board part No. :-12
Canadian model	Serial No. A700, 001-A700, 100	Serial No. A700, 101-
AEP model	Serial No. 500, 001-500, 900	Serial No. 500, 901-
UK model	Serial No. 600, 001-600, 300	Serial No. 600, 301-
West Germany model	_____	ALL
E model	_____	ALL

#### • Changed Part List

Ref. No.	Suffix of board part No. :-11	Suffix of board part No. :-12
R805	1-249-427-11 CARBON 6.8k 5% 1/4W	1-249-421-11 CARBON 2.2k 5% 1/4W

