

TA-F440E/F540E

SERVICE MANUAL

UK Model

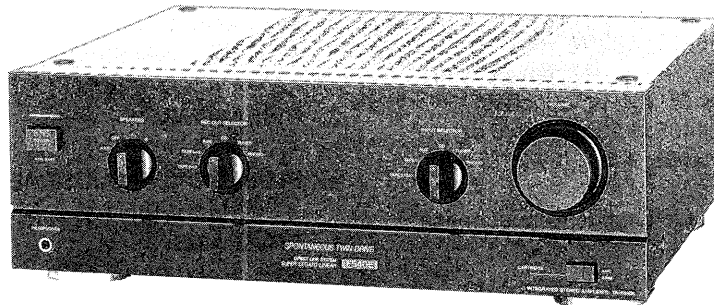

Photo : TA-F540E

SPECIFICATIONS

Amplifier

Continuous RMS power output (both channels driven simultaneously)

		TA-F440E	TA-F540E
DIN 1 kHz	4 ohms	110 W + 110 W	120 W + 120 W
	8 ohms	90 W + 90 W	100 W + 100 W
20 Hz - 20 kHz THD 0.008 %	8 ohms	80 W + 80 W	90 W + 90 W

Input

Input jack		Jack type	Sensitivity	Impedance	S/N (weighting network, input level)
PHONO	MM	Phono	2.0 mV	50 kilohms	92 dB (A, 5 mV)
	MC		170 μ V	100 ohms	75 dB (A, 0.5 mV)
TUNER, CD, AUX, TAPE/DAT		Phono	150 mV	50 kilohms	100 dB (150 mV)

Output

Output jack	Jack type	Voltage/impedance
REC OUT	Phono	Voltage 150 mV Impedance 1 kilohm
SPEAKERS	—	4 - 16 ohms (A or B) 8 - 16 ohms (A + B)
HEADPHONES	Stereo phone	Accepts low and high impedance headphones.

Intermodulation (IM) distortion (60 Hz:7 kHz = 4:1)

Less than 0.008 % at rated output

Frequency response

PHONO: RIAA equalization curve

± 0.5 dB

TUNER, CD, AUX, TAPE 1,

TAPE 2/DAT: 5 Hz - 120 kHz

± 3 dB

Residual noise

Less than 170 μ V, (network A)

Damping factor

70 (8 ohms, 1 kHz)

— Continued on page 2 —

INTEGRATED STEREO AMPLIFIER
SONY[®]

General

System Preamplifier: Low-noise, high-gain
 equalizer amplifier
 Power amplifier: Pure-
 complementary SEPP OCL
 power amplifier with all stages
 directly coupled

Power requirements 240 V, 50 Hz

Power consumption TA-F440E: 500 W
 TA-F540E: 520 W

Dimensions 430 × 148 × 372 mm (w/h/d)
 (17 × 5⁷/₈ × 14³/₄ inches)

Weight TA-F440E: 9.2 kg (20 lb 5 oz)
 TA-F540E: 9.4 kg (20 lb 15 oz)

Design and specifications subject to change without notice.



Note

This appliance conforms with EEC directive 87/308/EEC regarding interference suppression.

TABLE OF CONTENTS

<u>Section</u>	<u>Title</u>	<u>Page</u>
	Specifications	1
1. GENERAL		
1-1.	Connections	3
1-2.	Parts Identification	3
2. DISSASSEMBLY		4
3. ELECTRICAL ADJUSTMENTS		5
4. DIAGRAMS		
4-1.	Block Diagram	6
4-2.	Circuit Boards Location	8
4-3.	Printed Wiring Boards	9
4-4.	Schematic Diagram	13
5. EXPLODED VIEWS		
5-1.	Case, Front Panel	16
5-2.	Chassis, Back Panel	17
6. ELECTRICAL PARTS LIST		18

SAFETY-RELATED COMPONENT WARNING!!

COMPONENTS IDENTIFIED BY MARK  OR DOTTED LINE WITH MARK  ON THE SCHEMATIC DIAGRAMS AND IN THE PARTS LIST ARE CRITICAL TO SAFE OPERATION. REPLACE THESE COMPONENTS WITH SONY PARTS WHOSE PART NUMBERS APPEAR AS SHOWN IN THIS MANUAL OR IN SUPPLEMENTS PUBLISHED BY SONY.

SECTION 1 GENERAL

This section is extracted from instruction manual.

1-1. CONNECTIONS

Notes on Connection

- Connect the AC power cord last. Make sure power is off.
- Cord plugs and jacks are colour coded. Red plugs and jacks are for right channel (R) and white ones for left channel (L).
- Fully insert cable connectors into jacks. Loose connections may cause hum or noise.

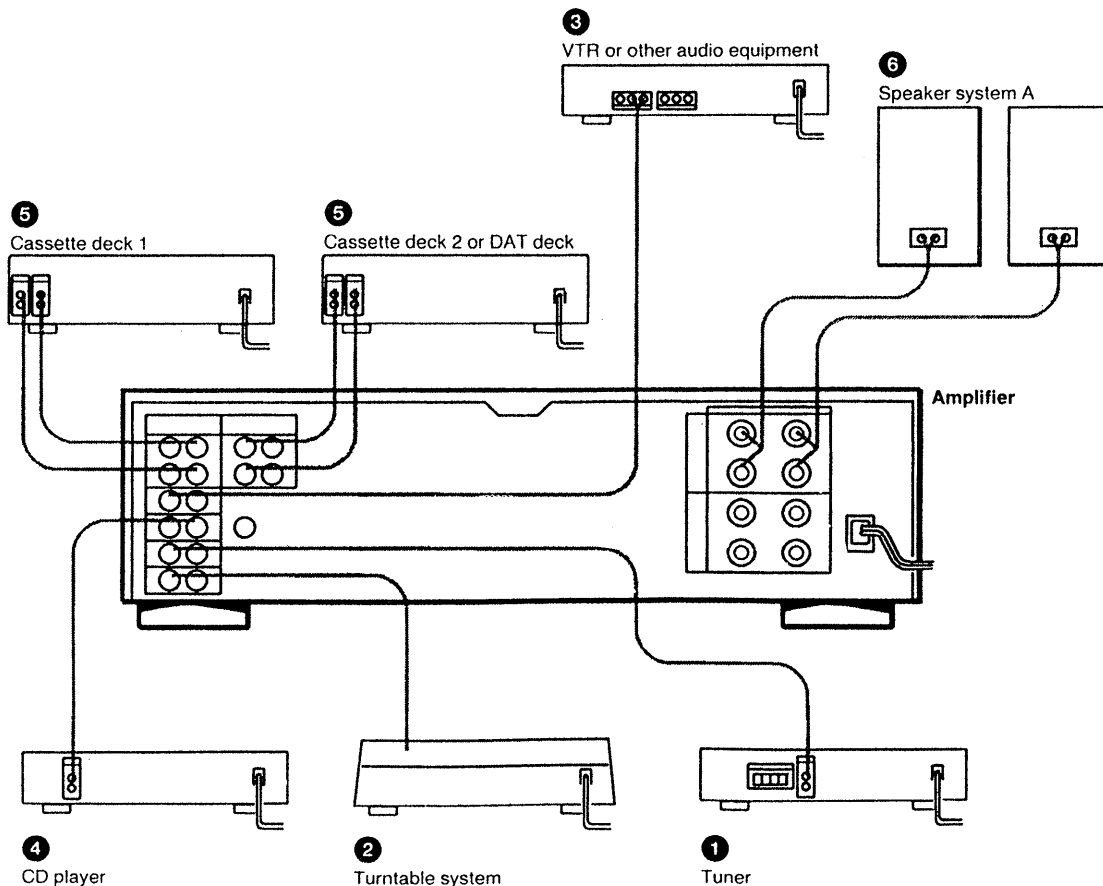

1-2. PARTS IDENTIFICATION

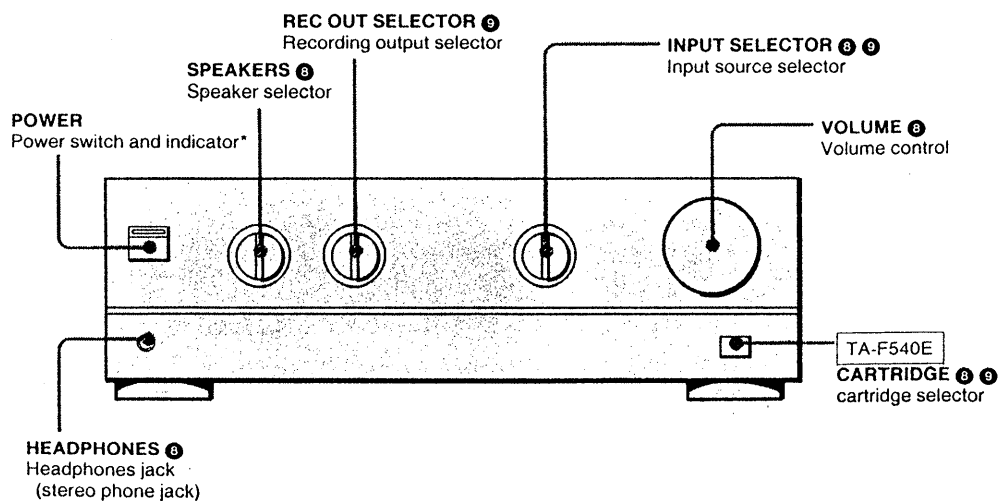

* When the power is turned on, the POWER indicator lights in red and immediately changed to green. If it remains in red or changes to red again, turn off the power, check that speakers and other devices are properly connected, and turn on the power again.

SECTION 2 DISASSEMBLY

2.1. DISASSEMBLING FOR BOARD CHECK (HP/LED BOARD)

Procedure :

- 1) Remove screws **1**, **2**.
- 2) Pull four knobs out **3**.
- 3) Press the claws **4**, **5**.
- 4) Remove front panel **6**.

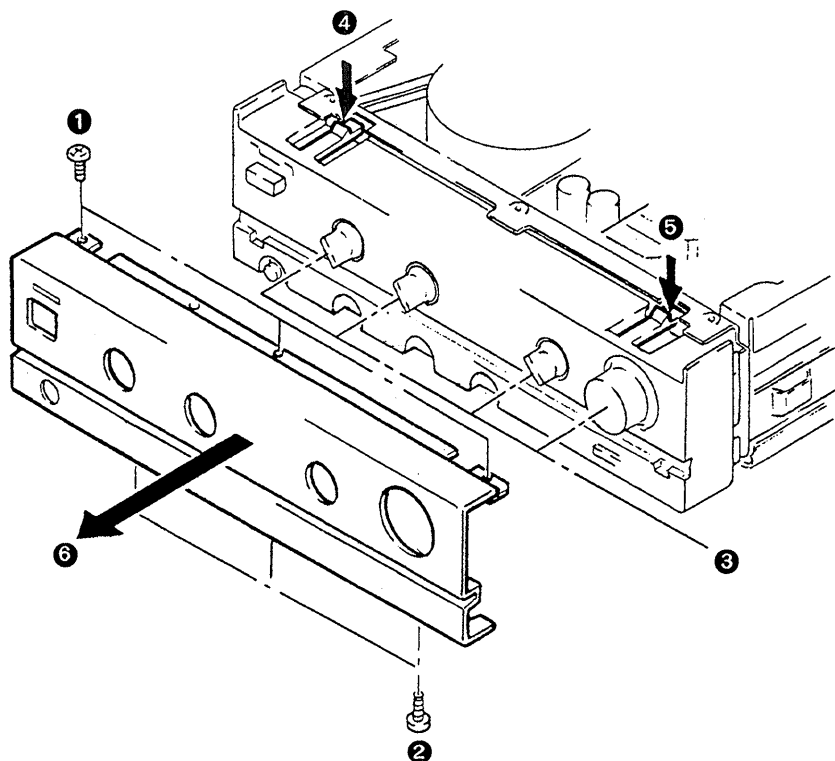

SECTION 3

ELECTRICAL ADJUSTMENTS

DC Bias Adjustment

Perform this adjustment when replacing the transistors of the power amplifier.

Setup :

- No signal (no load)
- Minimum Volume

1. Connect the DC volt meter to the TP1 and the TP2.
2. After the power is turned on, complete within 15 seconds to adjust RV500 (L-CH) and RV600 (R-CH) so that the bias voltage becomes $5\text{mV} \pm 0.3\text{mV}$.

Note : This adjustment must be completed within 15 seconds.

— Adjustment Location —
MAIN board

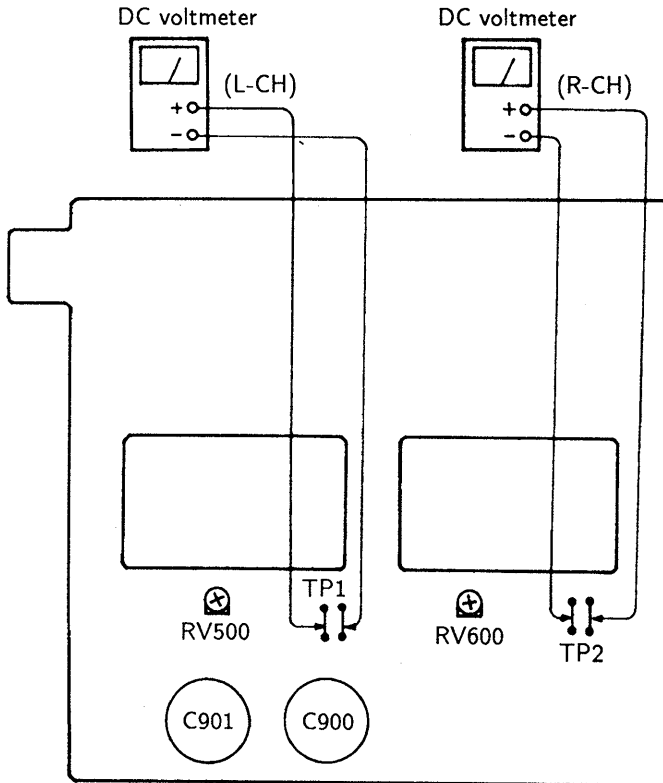

SECTION 4 DIAGRAMS

4-1. BLOCK DIAGRAM

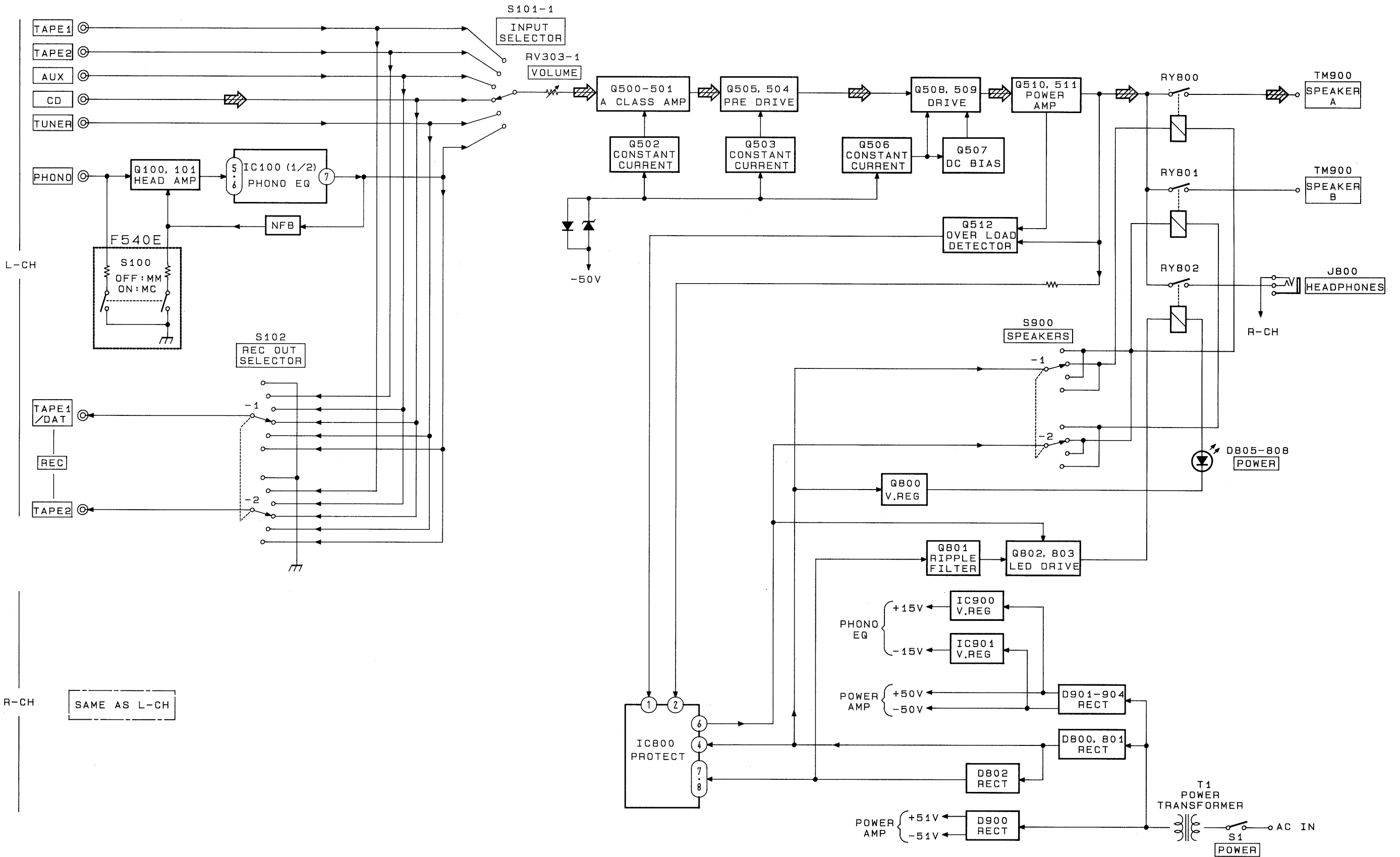

4-2. CIRCUIT BOARDS LOCATION

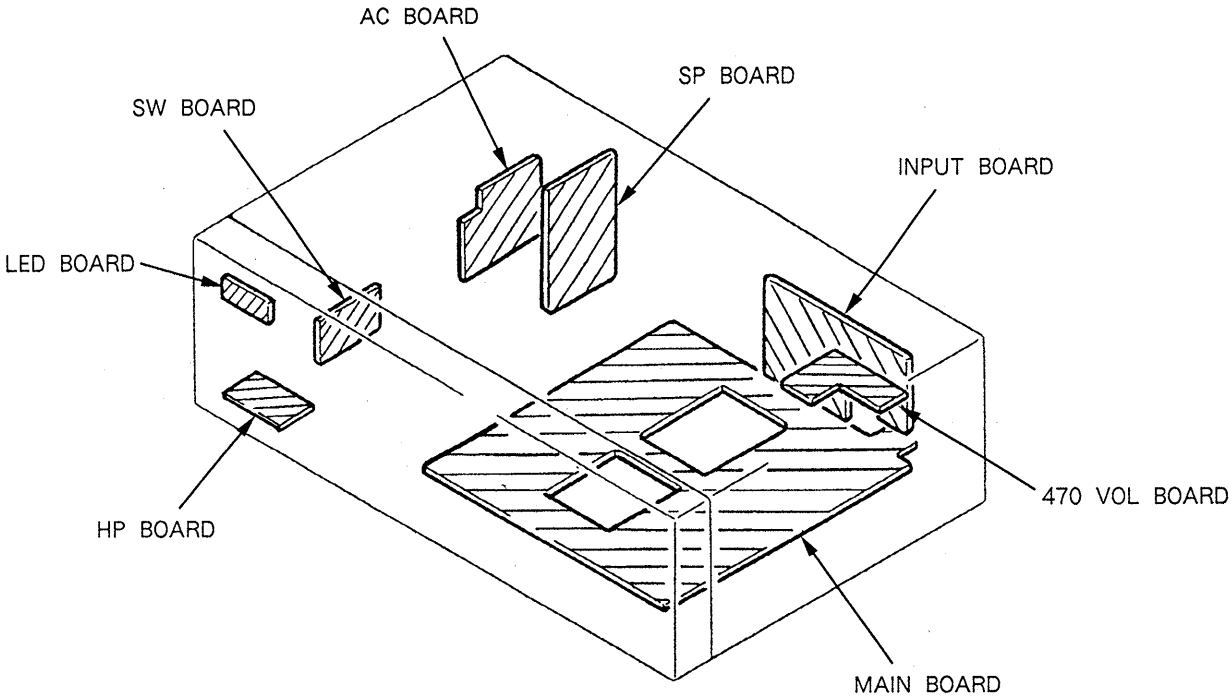

4-3. PRINTED WIRING BOARDS

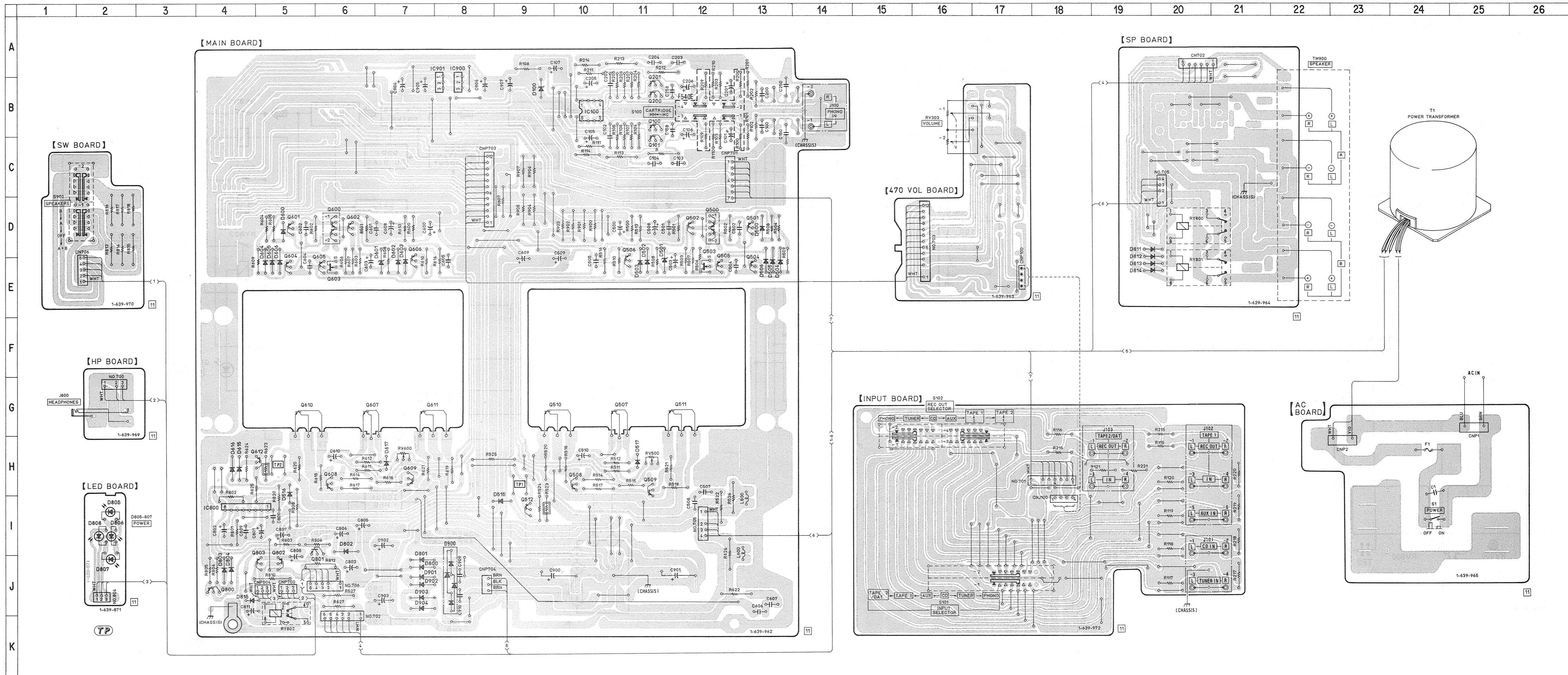

• SEMICONDUCTOR LOCATION

Ref. No.	Location	Ref. No.	Location
D100	B-9	IC100	B-10
D500	D-13	IC800	I-4
D501	E-11	IC900	B-8
D502	E-11	IC901	B-8
D503	E-11		
D504	E-13	Q100	B-11
D505	E-13	Q101	C-11
D506	E-13	Q200	B-11
D515	I-9	Q201	B-11
D516	I-5	Q500	D-12
D517	H-11	Q501	D-13
D600	D-5	Q502	D-12
D601	E-7	Q503	E-12
D602	E-7	Q504	E-13
D603	E-7	Q505	E-12
D604	E-5	Q506	E-11
D605	E-5	Q507	G-11
D606	E-5	Q508	H-10
D615	H-4	Q509	H-11
D616	H-4	Q510	G-9
D617	H-7	Q511	G-12
D800	J-7	Q512	I-9
D801	J-7	Q600	D-6
D802	I-6	Q601	D-5
D803	J-4	Q602	D-6
D804	J-4		
D805	I-2	Q603	E-6
D806	I-2	Q604	E-5
D807	J-2	Q605	E-6
D808	I-2	Q606	E-7
D811	D-20	Q607	G-6
D812	E-20	Q608	H-6
D813	E-20	Q609	H-7
D814	E-20	Q610	G-5
D815	J-4	Q611	G-7
D815	J-4	Q612	H-5
D900	J-8		
D901	J-7	Q800	J-4
D902	J-7	Q801	J-6
D903	J-7	Q802	J-5
D903	J-7	Q803	J-5
D904	J-7		

Note :
 ○ — : parts extracted from the component side.

• SEMICONDUCTOR LEAD LAYOUTS

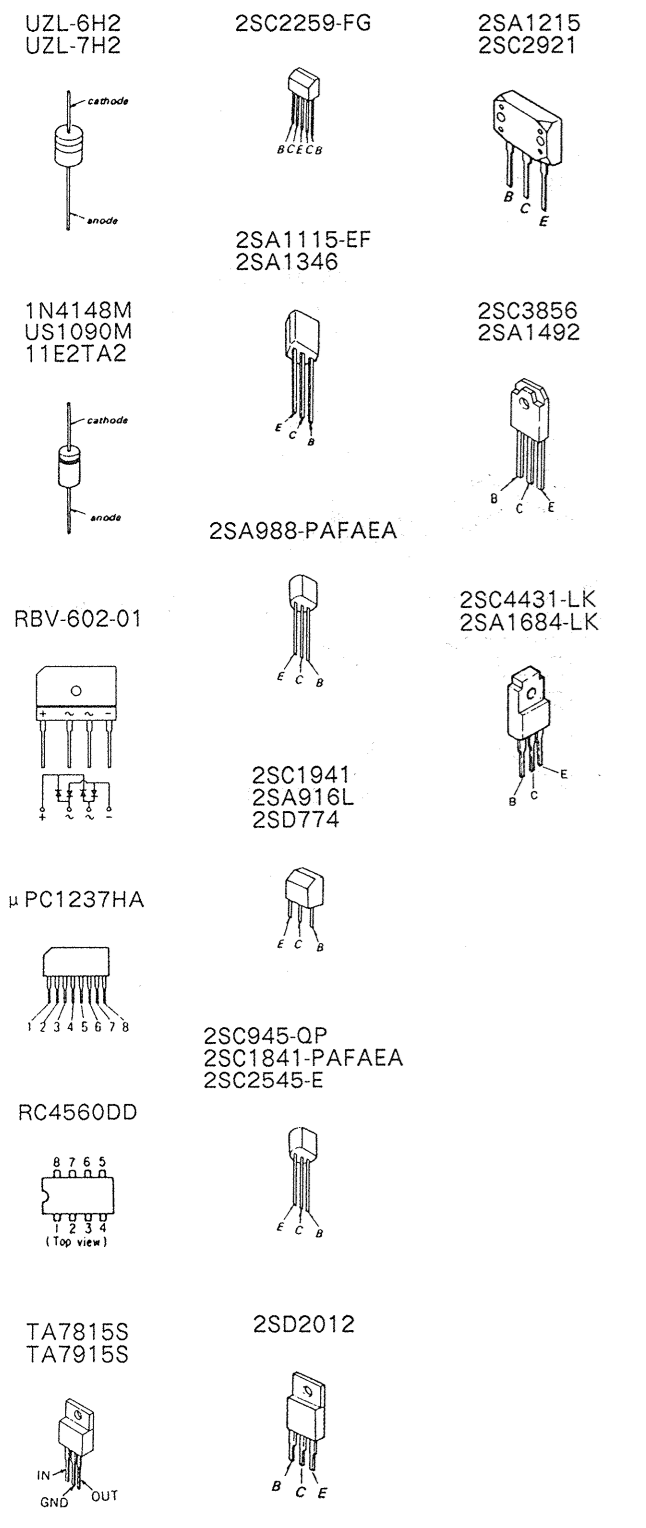

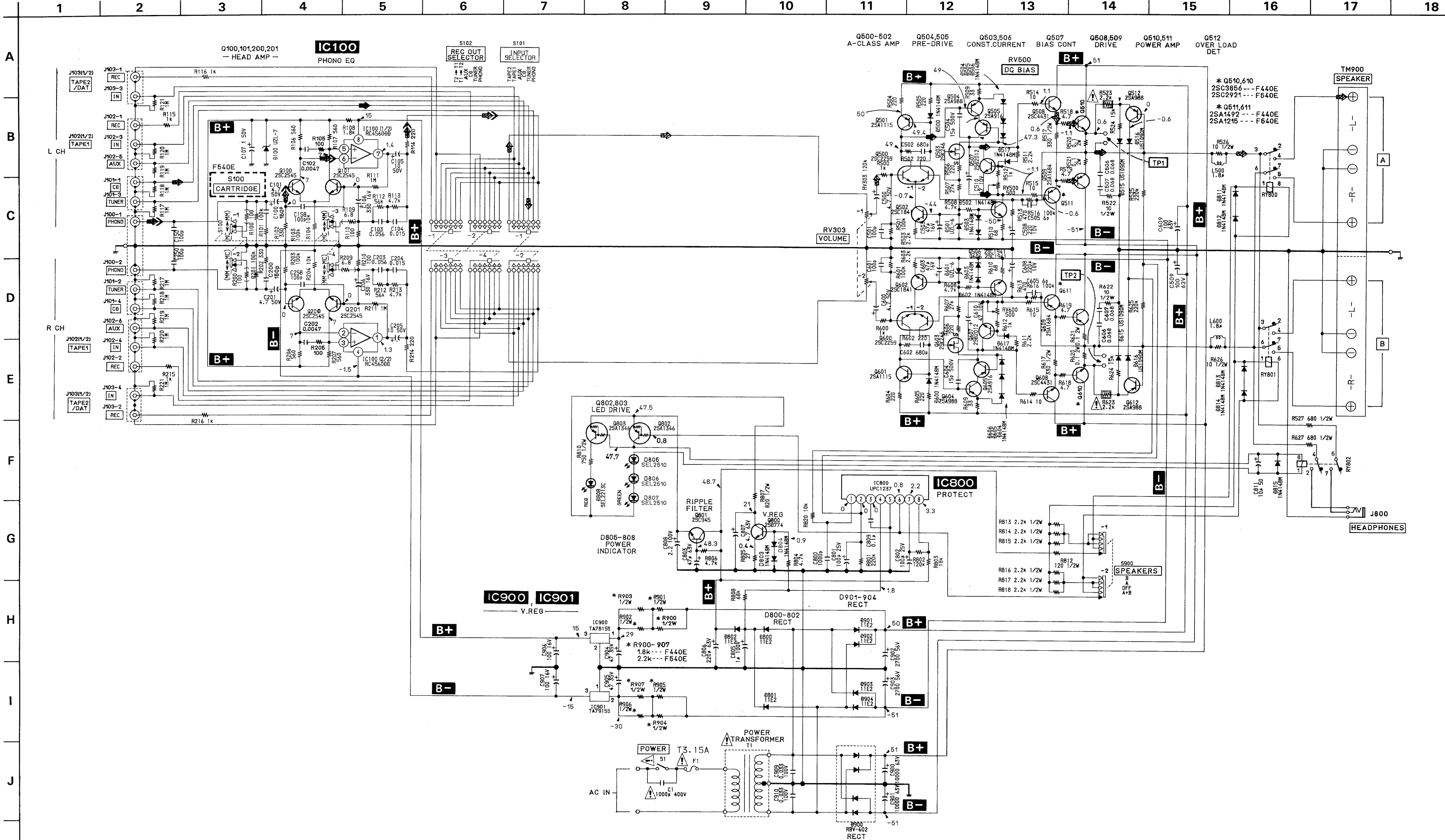

Note:

- All capacitors are in μF unless otherwise noted. pF: μF 50VV or less are not indicated except for electrolytics and tantalums.
- All resistors are in Ω and $\frac{1}{4}W$ or less unless otherwise specified.
- : nonflammable resistor.

Note: The components identified by mark or dotted line with mark are critical for safety. Replace only with part number specified.

- B+** : B+ Line
- B-** : B- Line
- : adjustment for repair.
- Voltages are taken with a VOM (Input impedance 10M Ω). Voltage variations may be noted due to normal production tolerances.
- Signal path.
- : CD
- : PHONO

• IC BLOCK DIAGRAM $\mu PC1237HA$

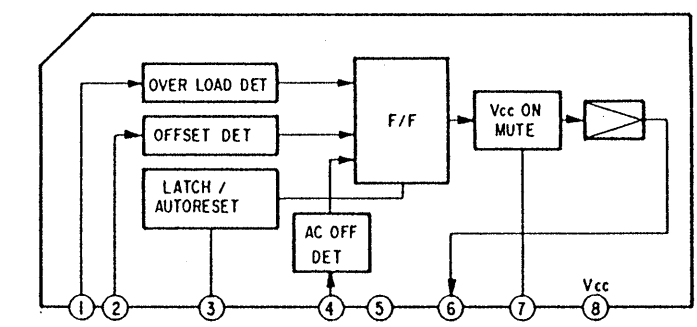

SECTION 5 EXPLODED VIEWS

NOTE:

- -XX, -X mean standardized parts, so they may have some differences from the original one.
- The construction parts of an assembled part are indicated with a collation number in the remark column.
- Color indication of Appearance Parts
Example:
KNOB, BALANCE (WHITE)...(RED)

↑ ↑
Parts color Cabinet's color

- Items marked "*" are not stocked since they are seldom required for routine service. Some delay should be anticipated when ordering these items.
- The mechanical parts with no reference number in the exploded views are not supplied.
- Hardware(#mark) list is given in the last of this parts list.

The components identified by mark or dotted line with mark are critical for safety. Replace only with part number specified.

5-1. CASE, FRONT PANEL

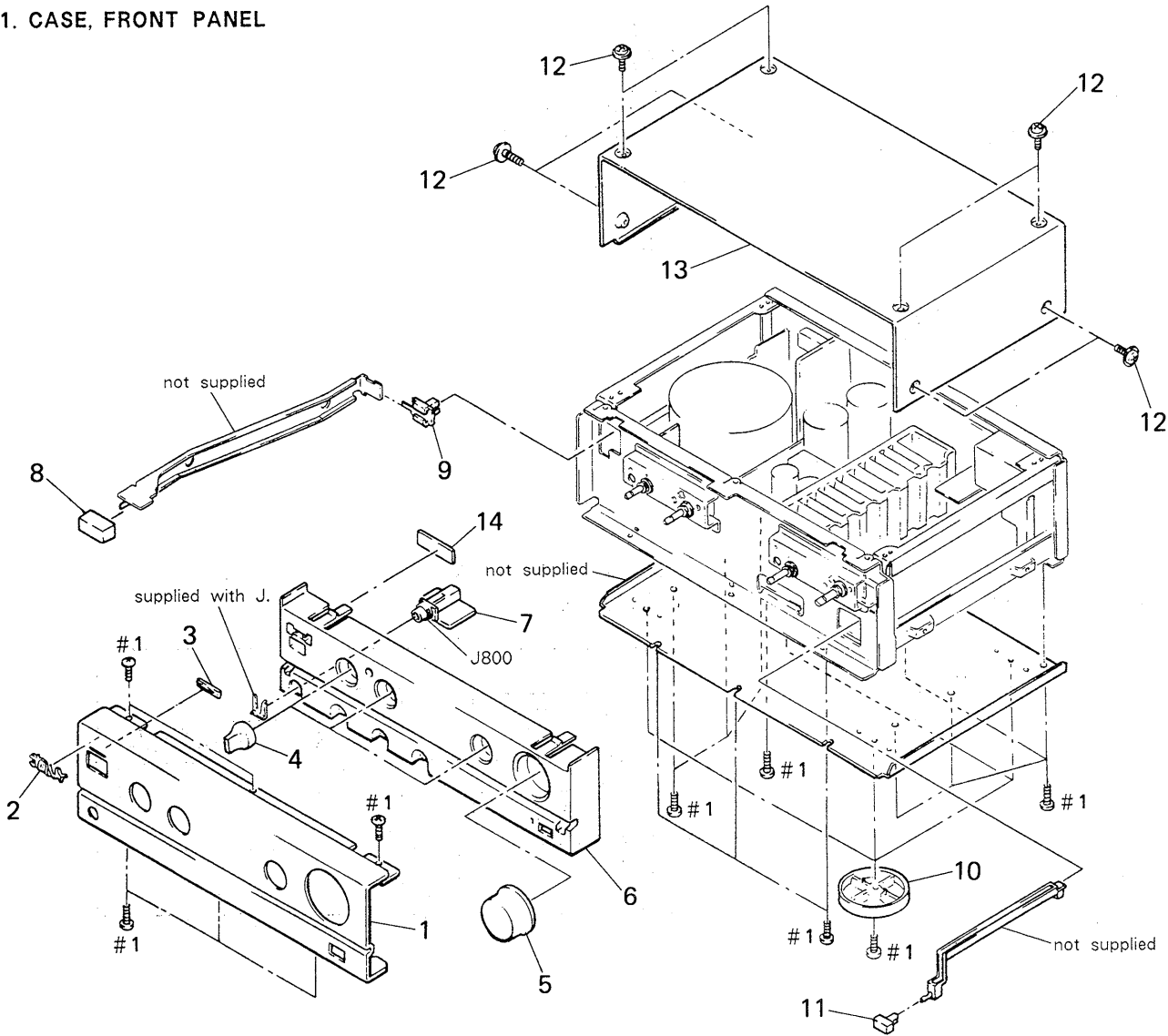

Ref. No.	Part No.	Description	Remark	Ref. No.	Part No.	Description	Remark
1	4-945-617-11	PANEL, FRONT (F540:UK)		7	* 1-639-969-11	PC BOARD, HP	
1	4-945-617-21	PANEL, FRONT (F440:UK)		8	4-929-289-01	BUTTON	
2	4-908-848-01	EMBLEM, SONY		9	4-875-466-11	JOINT (F2), KNOB	
3	4-945-175-01	INDICATOR (PSW)		10	X-4941-617-1	FOOT (58175) ASSY	
4	4-945-601-01	KNOB (F25)		11	4-945-176-01	BUTTON (18X11) (CARTRIDGE) (F540:UK)	
5	X-4941-616-1	KNOB (R53) ASSY		12	3-704-366-01	SCREW (CASE) (M3X8)	
6	* 4-945-605-01	PANEL (BASE), FRONT		13	* 4-945-618-01	CASE	
				14	* 1-639-971-11	PC BOARD, LED	

5-2. CHASSIS, BACK PANEL

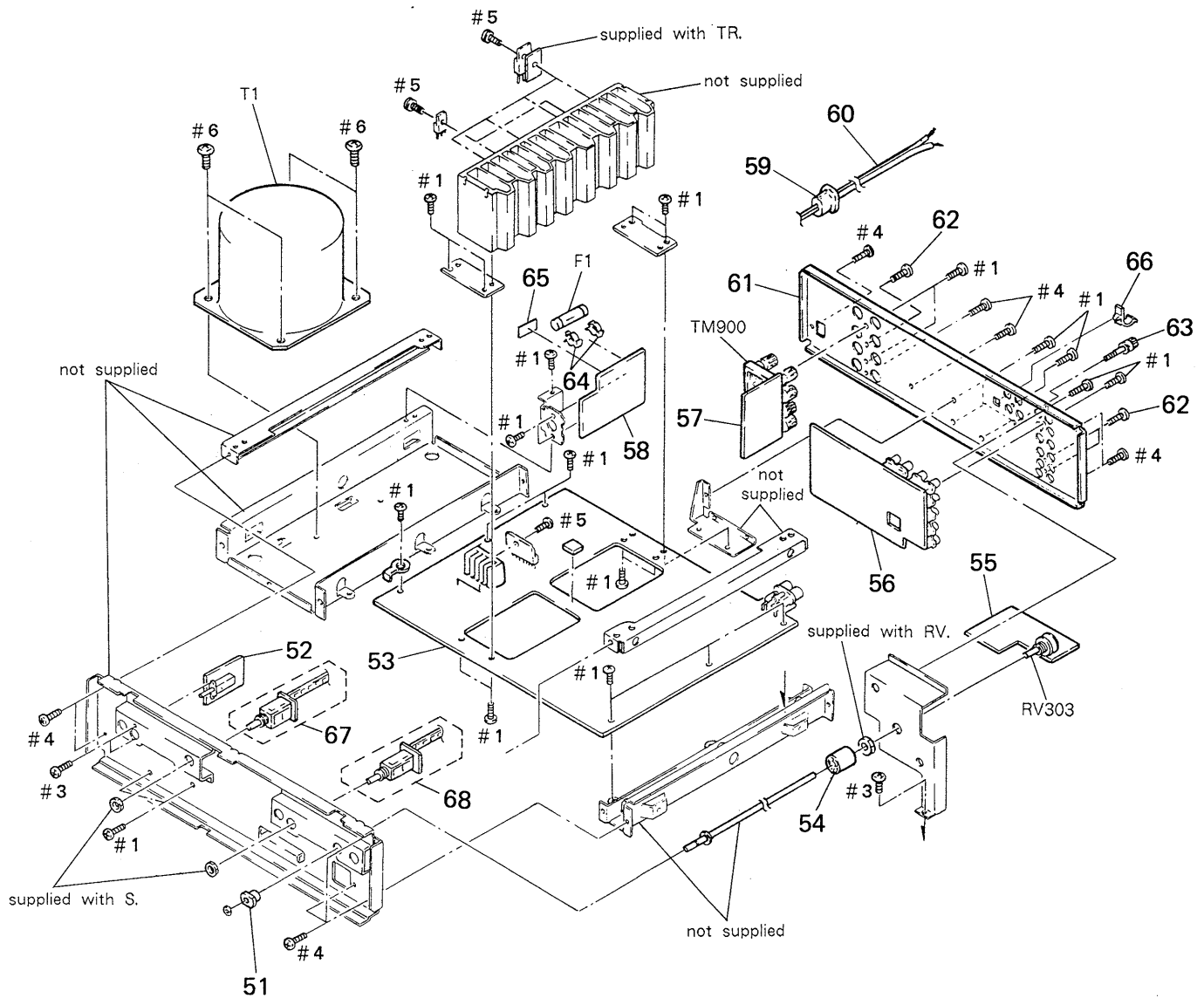

Note: The components identified by mark \triangle or dotted line with mark \triangle are critical for safety. Replace only with part number specified.

Ref. No.	Part No.	Description	Remark	Ref. No.	Part No.	Description	Remark
51	* 4-945-610-01	BEARING, VOL		61	* 4-944-985-41	PANEL, BACK (F440:UK)	
52	* 1-639-970-11	PC BOARD, SW		61	* 4-944-985-51	PANEL, BACK (F540:UK)	
53	* A-4345-209-A	MAIN BOARD, COMPLETE (F540:UK)		62	7-621-849-00	SCREW (BV/RING)	
53	* A-4345-625-A	MAIN BOARD, COMPLETE (F440:UK)		63	4-947-010-01	SCREW, FEEDER FIXED	
54	* 4-945-611-01	JOINT, VR		64	1-533-225-11	HOLDER, FUSE	
55	* 1-639-963-11	PC BOARD, 470 VOL		65	3-701-947-18	LABEL (T4A), FUSE	
56	* 1-639-972-11	PC BOARD, INPUT		66	* 2-379-614-01	HOOK	
57	* 1-639-964-11	PC BOARD, SP		67	1-572-795-12	SWITCH, ROTARY SLIDE	
58	* 1-639-965-11	PC BOARD, AC		68	1-572-796-11	SWITCH, ROTARY SLIDE	
59	* 3-703-244-00	BUSHING (2104), CORD		F1	\triangle 1-532-350-00	FUSE (4A 250V)	
60	• 1-575-652-11	CORD, POWER		T1	\triangle 1-450-569-11	TRANSFORMER, POWER (F440:UK)	
				T1	\triangle 1-450-570-11	TRANSFORMER, POWER (F540:UK)	

SECTION 6 ELECTRICAL PARTS LIST

MAIN 470 VOL

SP AC LED

NOTE:

- Due to standardization, replacements in the parts list may be different from the parts specified in the diagrams or the components used on the set.
- -XX, -X mean standardized parts, so they may have some difference from the original one.
- RESISTORS
All resistors are in ohms
METAL: Metal-film resistor
METAL OXIDE: Metal Oxide-film resistor
F: nonflammable

- Items marked "*" are not stocked since they are seldom required for routine service. Some delay should be anticipated when ordering these items.
- SEMICONDUCTORS
In each case, u: μ , for example:
uA.....: μ A....., uPA.....: μ PA.....
uPB.....: μ PB....., uPC.....: μ PC.....
uPD.....: μ PD.....
- CAPACITORS
uF: μ F
- COILS
uH: μ H

The components identified by mark Δ or dotted line with mark Δ are critical for safety. Replace only with part number specified.

When indicating parts by reference number, please include the board name.

Ref.No.	Part No.	Description	Remark	Ref.No.	Part No.	Description	Remark
* A-4345-209-A	MAIN BOARD, COMPLETE (F540:UK)			C204	1-130-485-00	MYLAR	0.015uF 5% 50V
* A-4345-625-A	MAIN BOARD, COMPLETE (F440:UK)			C205	1-126-059-11	ELECT	10uF 20% 50V
*****				C206	1-126-541-11	ELECT	330uF 20% 16V
* 1-639-963-11	470 VOL BOARD			C250	1-162-284-31	CERAMIC	150PF 10% 50V
*****				C258	1-164-073-11	CERAMIC	100PF 10% 50V
* 1-639-964-11	SP BOARD			C500	1-123-369-00	ELECT	4.7uF 20% 50V
*****				C501	1-164-073-11	CERAMIC	100PF 10% 50V
* 1-639-965-11	AC BOARD			C502	1-164-083-11	CERAMIC	680PF 10% 50V
*****				C503	1-124-477-11	ELECT	47uF 20% 25V
* 1-639-971-11	LED BOARD			C504	1-102-316-00	CERAMIC	15PF 5% 500V
*****				C505	1-102-943-00	CERAMIC	6.0PF +-0.5PF 50V
Δ 1-533-225-11	HOLDER, FUSE			C506	1-136-163-00	FILM	0.068uF 5% 50V
4-870-539-00	PLATE, GROUND			C507	1-136-163-00	FILM	0.068uF 5% 50V
7-685-647-79	SCREW +BVTP 3X10 TYPE2 IT-3			C508	1-126-335-11	ELECT	220uF 20% 10V
7-682-547-04	SCREW +BVTT 3X6 (S)			C509	1-124-130-00	ELECT	100uF 20% 63V
< CAPACITOR >				C510	1-123-306-00	ELECT	47uF 20% 10V
C1	1-161-741-00	CERAMIC	0.001uF 10% 400V	C600	1-123-369-00	ELECT	4.7uF 20% 50V
C100	1-164-075-11	CERAMIC	150PF 10% 50V	C601	1-164-073-11	CERAMIC	100PF 10% 50V
C101	1-123-369-00	ELECT	4.7uF 20% 50V	C602	1-164-083-11	CERAMIC	680PF 10% 50V
C102	1-161-377-00	CERAMIC	0.0047uF 30% 50V	C603	1-124-477-11	ELECT	47uF 20% 25V
C103	1-130-492-11	MYLAR	0.056uF 5% 50V	C604	1-102-316-00	CERAMIC	15PF 5% 500V
C104	1-130-485-00	MYLAR	0.015uF 5% 50V	C605	1-102-943-00	CERAMIC	6.0PF +-0.5PF 50V
C105	1-126-059-11	ELECT	10uF 20% 50V	C606	1-136-163-00	FILM	0.068uF 5% 50V
C106	1-126-541-11	ELECT	330uF 20% 16V	C607	1-136-163-00	FILM	0.068uF 5% 50V
C107	1-123-380-00	ELECT	1uF 20% 50V	C608	1-126-335-11	ELECT	220uF 20% 10V
C150	1-162-284-31	CERAMIC	150PF 10% 50V	C609	1-124-130-00	ELECT	100uF 20% 63V
C158	1-164-073-11	CERAMIC	100PF 10% 50V	C610	1-123-306-00	ELECT	47uF 20% 10V
C200	1-164-075-11	CERAMIC	150PF 10% 50V	C800	1-164-085-11	CERAMIC	0.001uF 10% 50V
C201	1-123-369-00	ELECT	4.7uF 20% 50V	C801	1-124-478-11	ELECT	100uF 20% 25V
C202	1-161-377-00	CERAMIC	0.0047uF 30% 50V	C802	1-124-478-11	ELECT	100uF 20% 25V
C203	1-130-492-11	MYLAR	0.056uF 5% 50V	C803	1-124-918-11	ELECT	47uF 20% 63V
				C805	1-124-791-11	ELECT	1.0uF 20% 100V
				C806	1-124-919-11	ELECT	220uF 20% 63V
				C807	1-124-927-11	ELECT	4.7uF 20% 100V
				C808	1-124-925-11	ELECT	2.2uF 20% 100V

MAIN	470 VOL	SP	AC	LED
------	---------	----	----	-----

Ref. No.	Part No.	Description	Remark
C809	1-136-165-00	FILM 0.1uF	5% 50V
C811	1-124-907-11	ELECT 10uF	20% 50V
C900	1-125-684-11	ELECT 10000uF	20% 63V (F440:UK)
C900	1-125-685-11	ELECT 10000uF	20% 63V (F540:UK)
C901	1-125-684-11	ELECT 10000uF	20% 63V (F440:UK)
C901	1-125-685-11	ELECT 10000uF	20% 63V (F540:UK)
C902	1-124-922-11	ELECT 1000uF	20% 63V (F440:UK)
C902	1-128-358-11	ELECT 2700uF	20% 56V (F540:UK)
C903	1-124-922-11	ELECT 1000uF	20% 63V (F440:UK)
C903	1-128-358-11	ELECT 2700uF	20% 56V (F540:UK)
C904	1-124-918-11	ELECT 47uF	20% 63V
C905	1-124-918-11	ELECT 47uF	20% 63V
C906	1-124-122-11	ELECT 100uF	20% 50V
C907	1-124-122-11	ELECT 100uF	20% 50V
C909	1-106-379-12	MYLAR 0.033uF	5% 200V
C910	1-106-379-12	MYLAR 0.033uF	5% 200V

< CONNECTOR >

CNP1	* 1-568-226-11	PIN, CONNECTOR 2P
CNP2	* 1-564-321-21	PIN, CONNECTOR 2P
CNP100	1-560-941-00	PIN, CONNECTOR 4P
CNP700	* 1-564-506-11	PLUG, CONNECTOR 3P
CNP701	* 1-564-510-11	PLUG, CONNECTOR 7P
CNP702	* 1-564-509-11	PLUG, CONNECTOR 6P
CNP703	* 1-564-515-11	PLUG, CONNECTOR 12P
CNP704	* 1-564-104-00	PIN, CONNECTOR 3P
CNP804	* 1-564-337-00	PIN, CONNECTOR 3P

< DIODE >

D100	8-719-933-50	DIODE UZL-7H2-TP
D500	8-719-912-20	DIODE 1SS120
D501	8-719-933-36	DIODE UZL-6H2-TP
D502	8-719-912-20	DIODE 1SS120
D503	8-719-912-20	DIODE 1SS120
D504	8-719-912-20	DIODE 1SS120
D505	8-719-912-20	DIODE 1SS120
D506	8-719-912-20	DIODE 1SS120
D515	8-719-815-85	DIODE 1S1585
D516	8-719-815-85	DIODE 1S1585
D517	8-719-912-20	DIODE 1SS120
D600	8-719-912-20	DIODE 1SS120
D601	8-719-933-36	DIODE UZL-6H2-TP
D602	8-719-912-20	DIODE 1SS120
D603	8-719-912-20	DIODE 1SS120
D604	8-719-912-20	DIODE 1SS120
D605	8-719-912-20	DIODE 1SS120
D606	8-719-912-20	DIODE 1SS120

Ref. No.	Part No.	Description	Remark
D615	8-719-815-85	DIODE 1S1585	
D616	8-719-815-85	DIODE 1S1585	
D617	8-719-912-20	DIODE 1SS120	
D800	8-719-200-82	DIODE 11ES2	
D801	8-719-200-82	DIODE 11ES2	
D802	8-719-200-82	DIODE 11ES2	
D803	8-719-912-20	DIODE 1SS120	
D804	8-719-912-20	DIODE 1SS120	
D805	8-719-303-02	DIODE SEL2510C-D-TP2	
D806	8-719-303-02	DIODE SEL2510C-D-TP2	
D807	8-719-303-02	DIODE SEL2510C-D-TP2	
D808	8-719-302-23	DIODE SEL2213C-C-TP	
D811	8-719-912-20	DIODE 1SS120	
D812	8-719-912-20	DIODE 1SS120	
D813	8-719-912-20	DIODE 1SS120	
D814	8-719-912-20	DIODE 1SS120	
D815	8-719-912-20	DIODE 1SS120	
D900	8-719-302-38	DIODE RBV-602-01	
D901	8-719-200-82	DIODE 11ES2	
D902	8-719-200-82	DIODE 11ES2	
D903	8-719-200-82	DIODE 11ES2	
D904	8-719-200-82	DIODE 11ES2	

< FUSE >

F1	Δ 1-532-350-00	FUSE (4A 250V)
----	-----------------------	----------------

< IC >

IC100	8-759-981-98	IC RC4560DD
IC800	8-759-111-68	IC uPC1237HA
IC900	8-759-231-59	IC TA7815S
IC901	8-759-245-87	IC TA7915S

< JACK >

J100	* 1-573-140-21	JACK, PIN 2P (PHONO IN)
------	----------------	-------------------------

< COIL >

L500	1-428-133-11	COIL, AIR-CORE 1.8uH
L600	1-428-133-11	COIL, AIR-CORE 1.8uH

< TRANSISTOR >

Q100	8-729-354-52	TRANSISTOR 2SC2545TP-E
Q101	8-729-354-52	TRANSISTOR 2SC2545TP-E
Q200	8-729-354-52	TRANSISTOR 2SC2545TP-E
Q201	8-729-354-52	TRANSISTOR 2SC2545TP-E
Q500	8-729-620-17	TRANSISTOR 2SC2259-FG
Q501	8-729-119-76	TRANSISTOR 2SA1175-HFE
Q502	8-729-140-84	TRANSISTOR 2SC1841TP-PAFAEA
Q503	8-729-224-62	TRANSISTOR 2SK246GR-TPE2
Q504	8-729-140-82	TRANSISTOR 2SA988TP-PAFAEA
Q505	8-729-803-76	TRANSISTOR 2SA916LTP

Note: The components identified by mark Δ or dotted line with mark Δ are critical for safety. Replace only with part number specified.

MAIN	470 VOL	SP	AC	LED
------	---------	----	----	-----

Ref. No.	Part No.	Description	Remark
Q506	8-729-142-01	TRANSISTOR 2SC1941-T-LK	
Q507	8-729-209-15	TRANSISTOR 2SD2012	
Q508	8-729-141-46	TRANSISTOR 2SC4431-LK	
Q509	8-729-141-37	TRANSISTOR 2SA1684-LK	
Q510	8-729-320-04	TRANSISTOR 2SC2921M-Y (F540:UK)	
Q510	8-729-320-71	TRANSISTOR 2SC3856-OY (F440:UK)	
Q511	8-729-320-02	TRANSISTOR 2SA1215M-Y (F540:UK)	
Q511	8-729-320-72	TRANSISTOR 2SA1492-OY (F440:UK)	
Q512	8-729-140-82	TRANSISTOR 2SA988TP-PAFAEA	
Q600	8-729-620-17	TRANSISTOR 2SC2259-FG	
Q601	8-729-119-76	TRANSISTOR 2SA1175-HFE	
Q602	8-729-140-84	TRANSISTOR 2SC1841TP-PAFAEA	
Q603	8-729-224-62	TRANSISTOR 2SK246GR-TPE2	
Q604	8-729-140-82	TRANSISTOR 2SA988TP-PAFAEA	
Q605	8-729-803-76	TRANSISTOR 2SA916LTP	
Q606	8-729-142-01	TRANSISTOR 2SC1941-T-LK	
Q607	8-729-209-15	TRANSISTOR 2SD2012	
Q608	8-729-141-46	TRANSISTOR 2SC4431-LK	
Q609	8-729-141-37	TRANSISTOR 2SA1684-LK	
Q610	8-729-320-04	TRANSISTOR 2SC2921M-Y (F540:UK)	
Q610	8-729-320-71	TRANSISTOR 2SC3856-OY (F440:UK)	
Q611	8-729-320-02	TRANSISTOR 2SA1215M-Y (F540:UK)	
Q611	8-729-320-72	TRANSISTOR 2SA1492-OY (F440:UK)	
Q612	8-729-140-82	TRANSISTOR 2SA988TP-PAFAEA	
Q800	8-729-140-96	TRANSISTOR 2SD774-T-34	
Q801	8-729-194-57	TRANSISTOR 2SC945TP-QP	
Q802	8-729-900-63	TRANSISTOR DTA124ES	
Q803	8-729-900-63	TRANSISTOR DTA124ES	
< RESISTOR >			
R100	1-247-700-11	CARBON 100 5% 1/4W (F540:UK)	
R101	1-249-469-11	CARBON 100K 5% 1/4W	
R102	1-247-706-11	CARBON 330 5% 1/4W	
R103	1-249-469-11	CARBON 100K 5% 1/4W	
R104	1-247-725-11	CARBON 10K 5% 1/4W	
R105	1-247-700-11	CARBON 100 5% 1/4W	
R106	1-247-710-11	CARBON 560 5% 1/4W	
R107	1-247-710-11	CARBON 560 5% 1/4W	
R108	1-247-716-11	CARBON 1.8K 5% 1/4W	
R109	1-249-457-11	CARBON 6.8 5% 1/4W (F540:UK)	
R110	1-247-700-11	CARBON 100 5% 1/4W	
R111	1-246-545-00	CARBON 1.0M 5% 1/4W	
R112	1-249-844-11	CARBON 56K 1% 1/2W	
R113	1-249-818-11	CARBON 4.7K 1% 1/2W	
R114	1-247-704-11	CARBON 220 5% 1/4W	
R200	1-247-700-11	CARBON 100 5% 1/4W (F540:UK)	

Ref. No.	Part No.	Description	Remark
R201	1-249-469-11	CARBON 100K 5% 1/4W	
R202	1-247-706-11	CARBON 330 5% 1/4W	
R203	1-249-469-11	CARBON 100K 5% 1/4W	
R204	1-247-725-11	CARBON 10K 5% 1/4W	
R205	1-247-700-11	CARBON 100 5% 1/4W	
R206	1-247-710-11	CARBON 560 5% 1/4W	
R207	1-247-710-11	CARBON 560 5% 1/4W	
R209	1-249-457-11	CARBON 6.8 5% 1/4W (F540:UK)	
R210	1-247-700-11	CARBON 100 5% 1/4W	
R211	1-246-545-00	CARBON 1.0M 5% 1/4W	
R212	1-249-844-11	CARBON 56K 1% 1/2W	
R213	1-249-818-11	CARBON 4.7K 1% 1/2W	
R214	1-247-704-11	CARBON 220 5% 1/4W	
R500	1-247-713-11	CARBON 1K 5% 1/4W	
R501	1-249-469-11	CARBON 100K 5% 1/4W	
R502	1-247-704-11	CARBON 220 5% 1/4W	
R503	1-247-717-11	CARBON 2.2K 5% 1/4W	
R504	1-247-704-11	CARBON 220 5% 1/4W	
R505	1-247-704-11	CARBON 220 5% 1/4W	
R506	1-247-704-11	CARBON 220 5% 1/4W	
R507	1-249-463-11	CARBON 27K 5% 1/4W	
R508	1-247-721-11	CARBON 4.7K 5% 1/4W	
R509	1-247-694-11	CARBON 33 5% 1/4W	
R510	1-247-698-11	CARBON 68 5% 1/4W	
R511	1-247-717-11	CARBON 2.2K 5% 1/4W	
R512	1-247-713-11	CARBON 1K 5% 1/4W	
R513	1-249-915-11	CARBON 470 1% 1/4W	
R514	△ 1-247-688-11	CARBON 10 5% 1/4W	
R515	△ 1-247-688-11	CARBON 10 5% 1/4W	
R516	1-249-469-11	CARBON 100K 5% 1/4W	
R517	△ 1-247-745-11	CARBON 330 5% 1/2W	
R518	△ 1-249-455-11	CARBON 4.7 5% 1/4W	
R519	△ 1-249-455-11	CARBON 4.7 5% 1/4W	
R520	1-217-611-00	RES. METAL PLATE 0.1	
R521	1-217-611-00	RES. METAL PLATE 0.1	
R522	1-247-727-11	CARBON 10 5% 1/2W	
R523	△ 1-247-717-11	CARBON 2.2K 5% 1/4W	
R524	1-249-460-11	CARBON 15K 5% 1/4W	
R525	1-247-887-00	CARBON 220K 5% 1/4W	
R526	1-247-727-11	CARBON 10 5% 1/2W	
R527	1-247-750-11	CARBON 680 5% 1/2W	
R600	1-247-713-11	CARBON 1K 5% 1/4W	
R601	1-249-469-11	CARBON 100K 5% 1/4W	
R602	1-247-704-11	CARBON 220 5% 1/4W	
R603	1-247-717-11	CARBON 2.2K 5% 1/4W	
R604	1-247-704-11	CARBON 220 5% 1/4W	
R605	1-247-704-11	CARBON 220 5% 1/4W	
R606	1-247-704-11	CARBON 220 5% 1/4W	
R607	1-249-463-11	CARBON 27K 5% 1/4W	

Note: The components identified by mark △ or dotted line with mark △ are critical for safety. Replace only with part number specified.

MAIN

470 VOL

SP

AC

LED

HP

SW

INPUT

Ref. No.	Part No.	Description	Remark		
R608	1-247-721-11	CARBON	4.7K	5%	1/4W
R609	1-247-694-11	CARBON	33	5%	1/4W
R610	1-247-698-11	CARBON	68	5%	1/4W
R611	1-247-717-11	CARBON	2.2K	5%	1/4W
R612	1-247-713-11	CARBON	1K	5%	1/4W
R613	1-249-915-11	CARBON	470	1%	1/4W
R614	△ 1-247-688-11	CARBON	10	5%	1/4W
R615	△ 1-247-688-11	CARBON	10	5%	1/4W
R616	1-249-469-11	CARBON	100K	5%	1/4W
R617	△ 1-247-745-11	CARBON	330	5%	1/2W
R618	△ 1-249-455-11	CARBON	4.7	5%	1/4W
R619	△ 1-249-455-11	CARBON	4.7	5%	1/4W
R620	1-217-611-00	RES, METAL PLATE 0.1			
R621	1-217-611-00	RES, METAL PLATE 0.1			
R622	1-247-727-11	CARBON	10	5%	1/2W
R623	△ 1-247-717-11	CARBON	2.2K	5%	1/4W
R624	1-249-460-11	CARBON	15K	5%	1/4W
R625	1-247-887-00	CARBON	220K	5%	1/4W
R626	1-247-727-11	CARBON	10	5%	1/2W
R627	1-247-750-11	CARBON	680	5%	1/2W
R801	1-247-887-00	CARBON	220K	5%	1/4W
R802	1-247-881-00	CARBON	120K	5%	1/4W
R803	1-249-461-11	CARBON	18K	5%	1/4W
R804	1-247-721-11	CARBON	4.7K	5%	1/4W
R805	1-247-693-11	CARBON	27	5%	1/4W
R806	1-247-721-11	CARBON	4.7K	5%	1/4W
R807	1-247-751-11	CARBON	820	5%	1/2W
R808	1-249-467-11	CARBON	68K	5%	1/4W
R810	1-247-237-00	CARBON	750	5%	1/2W
R812	1-247-740-11	CARBON	120	5%	1/2W
R820	1-247-725-11	CARBON	10K	5%	1/4W
R900	1-247-755-11	CARBON	1.8K	5%	1/2W(F440:UK)
R900	1-247-756-11	CARBON	2.2K	5%	1/2W(F540:UK)
R901	1-247-755-11	CARBON	1.8K	5%	1/2W(F440:UK)
R901	1-247-756-11	CARBON	2.2K	5%	1/2W(F540:UK)
R902	1-247-755-11	CARBON	1.8K	5%	1/2W(F440:UK)
R902	1-247-756-11	CARBON	2.2K	5%	1/2W(F540:UK)
R903	1-247-755-11	CARBON	1.8K	5%	1/2W(F440:UK)
R903	1-247-756-11	CARBON	2.2K	5%	1/2W(F540:UK)
R904	1-247-755-11	CARBON	1.8K	5%	1/2W(F440:UK)
R904	1-247-756-11	CARBON	2.2K	5%	1/2W(F540:UK)
R905	1-247-755-11	CARBON	1.8K	5%	1/2W(F440:UK)
R905	1-247-756-11	CARBON	2.2K	5%	1/2W(F540:UK)
R906	1-247-755-11	CARBON	1.8K	5%	1/2W(F440:UK)
R906	1-247-756-11	CARBON	2.2K	5%	1/2W(F540:UK)

Ref. No.	Part No.	Description	Remark		
R907	1-247-755-11	CARBON	1.8K	5%	1/2W(F440:UK)
R907	1-247-756-11	CARBON	2.2K	5%	1/2W(F540:UK)
		< VARIABLE RESISTOR >			
RV303	1-241-557-11	RES, VAR, CARBON 120K/120K			(VOLUME) (F440:UK)
RV303	1-241-558-11	RES, VAR, CARBON 120K/120K			(VOLUME) (F540:UK)
RV500	1-237-455-11	RES, ADJ, CARBON 500 (DC BIAS)			
RV600	1-237-455-11	RES, ADJ, CARBON 500 (DC BIAS)			
		< RELAY >			
RY800	1-515-501-00	RELAY			
RY801	1-515-501-00	RELAY			
RY802	1-515-787-21	RELAY			
		< TERMINAL >			
TM900	1-537-228-11	TERMINAL BOARD (SP)			
		< SWITCH >			
S1	△ 1-554-920-11	SWITCH, PUSH (AC POWER) (1 KEY)			
S100	1-571-111-11	SWITCH, PUSH (1 KEY) (CARTRIDGE)			

		* 1-639-969-11 HP BOARD			

		* 1-639-970-11 SW BOARD			

		* 1-639-972-11 INPUT BOARD			

		< CONNECTOR >			
CNJ100	1-562-087-00	SOCKET, CONNECTOR 4P			
CNP706	* 1-564-508-11	PLUG, CONNECTOR 5P			
		< JACK >			
J101	* 1-573-142-31	JACK, PIN 4P (CD IN) (TUNER IN)			
J102	1-568-978-11	JACK 6P (TAPE 1)			
J103	* 1-573-142-21	JACK, PIN 4P (TAPE 2/DAT)			
J800	1-507-796-71	JACK (HEADPHONES)			
		< RESISTOR >			
R115	1-247-713-11	CARBON	1K	5%	1/4W
R116	1-247-713-11	CARBON	1K	5%	1/4W
R117	1-246-545-00	CARBON	1.0M	5%	1/4W
R118	1-246-545-00	CARBON	1.0M	5%	1/4W
R119	1-246-545-00	CARBON	1.0M	5%	1/4W

Note: The components identified by mark △ or dotted line with mark △ are critical for safety. Replace only with part number specified.

HP SW INPUT

Ref. No.	Part No.	Description	Remark
R120	1-246-545-00	CARBON	1.0M 5% 1/4W
R121	1-246-545-00	CARBON	1.0M 5% 1/4W
R215	1-247-713-11	CARBON	1K 5% 1/4W
R216	1-247-713-11	CARBON	1K 5% 1/4W
R217	1-246-545-00	CARBON	1.0M 5% 1/4W
R218	1-246-545-00	CARBON	1.0M 5% 1/4W
R219	1-246-545-00	CARBON	1.0M 5% 1/4W
R220	1-246-545-00	CARBON	1.0M 5% 1/4W
R221	1-246-545-00	CARBON	1.0M 5% 1/4W
R813	1-247-756-11	CARBON	2.2K 5% 1/2W
R814	1-247-756-11	CARBON	2.2K 5% 1/2W
R815	1-247-756-11	CARBON	2.2K 5% 1/2W
R816	1-247-756-11	CARBON	2.2K 5% 1/2W
R817	1-247-756-11	CARBON	2.2K 5% 1/2W
R818	1-247-756-11	CARBON	2.2K 5% 1/2W

< SWITCH >

S101	1-571-669-11	SWITCH, SLIDE (INPUT SELECTOR)
S102	1-571-115-11	SWITCH, SLIDE (REC OUT SELECTOR)
S900	1-572-797-11	SWITCH, ROTARY SLIDE (SPEAKERS)

MISCELLANEOUS

60	⚠ 1-575-652-11	CORD, POWER
F1	⚠ 1-532-350-00	FUSE (4A 250V)
T1	⚠ 1-450-569-11	TRANSFORMER, POWER (F440:UK)
T1	⚠ 1-450-570-11	TRANSFORMER, POWER (F540:UK)

ACCESSORY & PACKING MATERIAL

- 3-753-594-41 MANUAL, INSTRUCTION
- * 4-931-985-01 CUSHION
- * 4-945-813-01 INDIVIDUAL CARTON (F540:UK)
- * 4-946-186-01 INDIVIDUAL CARTON (F440:UK)

HARDWARE LIST

# 1	7-685-646-79	SCREW +BVTP 3X8 TYPE2 IT-3
# 2	7-685-647-79	SCREW +BVTP 3X10 TYPE2 IT-3
# 3	7-682-547-04	SCREW +BVTT 3X6 (S)
# 4	7-682-547-09	SCREW +BVTT 3X6 (S)
# 5	7-682-549-04	SCREW +BVTT 3X10 (S)
# 6	7-682-560-04	SCREW +BVTT 4X6 (S)

Note: The components identified by mark ⚠ or dotted line with mark ⚠ are critical for safety. Replace only with part number specified.