

# TA-F244E/F444E

## SERVICE MANUAL

*AEP Model  
UK Model*

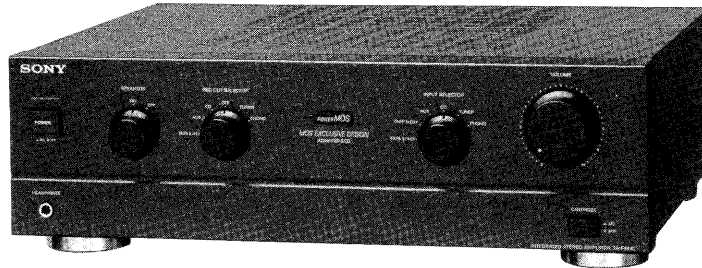

Photo : TA-F444E

### SPECIFICATIONS

#### Amplifier

Continuous RMS power output (both channels driven simultaneously)

		TA-F444E	TA-F244E
DIN, 1 kHz	4 ohms*	70 W + 70 W	60 W + 60 W
	6 ohms	65 W + 65 W	55 W + 55 W
	8 ohms	55 W + 55 W	45 W + 45 W
20 Hz – 20 kHz, THD 0.03 %	4 ohms*	60 W + 60 W	50 W + 50 W
	6 ohms	55 W + 55 W	45 W + 45 W
	8 ohms	50 W + 50 W	40 W + 40 W

\* Except for Scandinavian countries, Switzerland, Spain and Portugal models

#### Output

Output jack	Jack type	Voltage/impedance
REC OUT	Phono	Voltage 150 mV Impedance 1 kohm
SPEAKERS	—	Model for Scandinavian countries, Switzerland, Spain and Portugal: 6 - 16 ohms (A or B) 12 - 16 ohms (A + B) Model for other countries: 4 - 16 ohms (A or B) 8 - 16 ohms (A + B)
HEADPHONES	Stereo phone jack	Accepts low and high impedance headphones

#### Input

Input jack	Jack type	Sensitivity	Impedance	S/N (weighting network, input level)
PHONO	MM	2.0 mV	50 kilohms	94 dB (A, 5 mV)
	MC (TA-F444E)	0.25 mV	100 ohms	76 dB (A, 0.5 mV)
TUNER, CD, AUX, TAPE 1/DAT, TAPE 2/MD	Phono	150 mV	50 kilohms	100 dB (150 mV)

INTEGRATED STEREO AMPLIFIER  
**SONY**®

## TABLE OF CONTENTS

Intermodulation (IM) distortion (60 Hz : 7 kHz = 4:1)	Less than 0.008 % at 10 W output
Frequency response	PHONO: RIAA equalization curve $\pm 0.5$ dB TUNER, CD, AUX, TAPE 1/DAT, TAPE 2/MD: 7 Hz – 100 kHz $\pm 0.5$ dB
Residual noise	Less than 170 $\mu$ V (network A)
Damping factor	50 (8 ohms, 1 kHz)

### General

System	Preamplifier: Low-noise, high-gain equalizer amplifier Power amplifier: Pure-complementary SEPP OCL power amplifier with all stages directly coupled
Power requirements	Model for U.K.: 240 V AC, 50 Hz Model for continental Europe: 220 – 230 V AC, 50/60 Hz
Power consumption	Model for Scandinavian countries, Switzerland, Spain and Portugal TA-F444E: 130 W TA-F244E: 115 W Model for other countries TA-F444E: 160 W TA-F244E: 150 W
Dimensions	Approx. 430 x 135 x 375 mm (w/h/d) (17 x 5 $\frac{3}{8}$ x 14 $\frac{7}{8}$ inches)
Mass	TA-F444E: Approx. 9.9 kg (21 lb 14 oz) TA-F244E: Approx. 8.5 kg (18 lb 12 oz)

Design and specifications are subject to change without notice.

### Note

This appliance conforms with EEC Directive 87/308/EEC regarding interference suppression.

Section	Title	Page
1.	GENERAL .....	3
2.	DISASSEMBLY	
2-1.	Disassembling for Board Check (HP/LED Board) .....	4
3.	ELECTRICAL ADJUSTMENT	
3-1.	DC Bias Adjustment .....	5
4.	DIAGRAMS	
4-1.	Circuit Boards Location .....	6
4-2.	Block Diagram .....	7
4-3.	Printed Wiring Boards .....	9
4-4.	Schematic Diagram .....	13
5.	EXPLODED VIEWS	
5-1.	Case and Front Panel Section .....	15
5-2.	Chassis section .....	16
5-3.	Back Panel Section .....	17
6.	ELECTRICAL PARTS LIST .....	18

### MODEL IDENTIFICATION

— BACK PANEL —

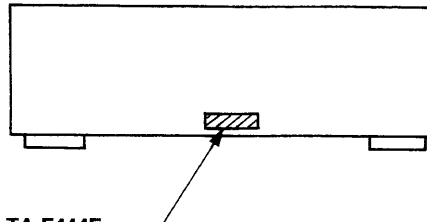

**TA-F444E :**  
 4-966-303-3□ : UK model  
 4-966-303-4□ : AEP1 model  
 4-966-303-5□ : AEP2 model  
**TA-F244E :**  
 4-966-303-6□ : UK model  
 4-966-303-7□ : AEP1 model  
 4-966-303-8□ : AEP2 model

#### Note:

There are two type of AEP models which are depend on countries.  
 AEP2 : Model for Scandinavian countries, Switzerland, Spain and Portugal.  
 AEP1 : Model for other European countries.

### SAFETY-RELATED COMPONENT WARNING !!

**COMPONENTS IDENTIFIED BY MARK  $\Delta$  OR DOTTED LINE WITH MARK  $\Delta$  ON THE SCHEMATIC DIAGRAMS AND IN THE PARTS LIST ARE CRITICAL TO SAFE OPERATION. REPLACE THESE COMPONENTS WITH SONY PARTS WHOSE PART NUMBERS APPEAR AS SHOWN IN THIS MANUAL OR IN SUPPLEMENTS PUBLISHED BY SONY.**

## SECTION 1 GENERAL

This section is extracted from  
instruction manual.

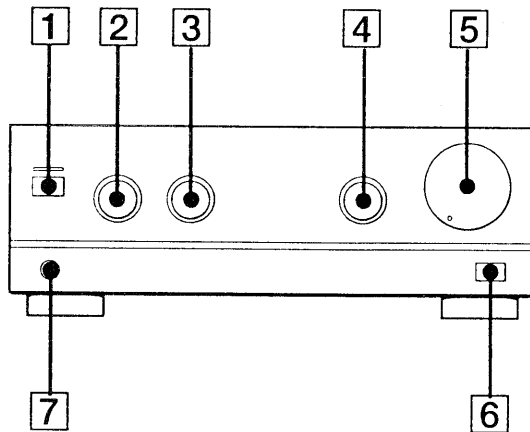

- 1 POWER switch and indicator\*
- 2 SPEAKERS selector
- 3 REC OUT SELECTOR
- 4 INPUT SELECTOR
- 5 VOLUME control
- 6 CARTRIDGE button (TA-F444E only)
- 7 HEADPHONES jack (stereo phone jack)

\* After the power is turned on, the POWER indicator lights in red and immediately changed to green. If it remains in red, turn off the power, check that speakers and other devices are properly connected, and turn on the power again.

## SECTION 2 DISASSEMBLY

### 2-1. DISASSEMBLING FOR BOARD CHECK (HP/LED BOARD)

**Procedure :**

- 1) Remove screws **1**, **2**.
- 2) Pull four knobs out **3**.
- 3) Press the claws **4**, **5**.
- 4) Remove front panel **6**.

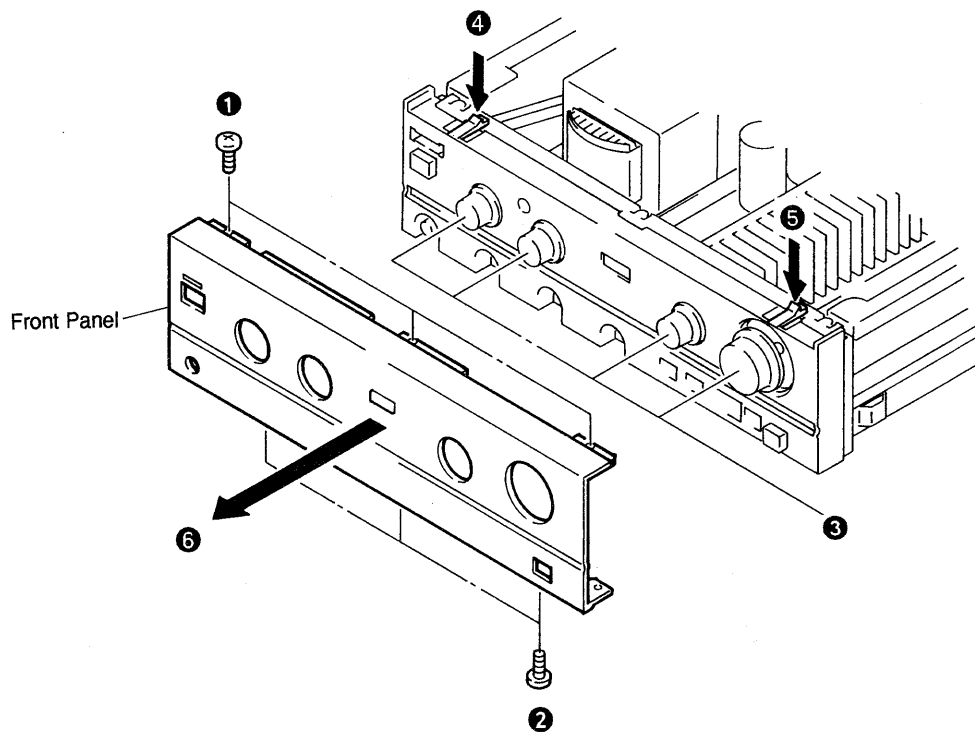

## SECTION 3 ELECTRICAL ADJUSTMENT

### DC Bias Adjustment

Perform this adjustment when replacing the transistors of the power amplifier.

**Setup :**

- No signal (no load)
  - Minimum Volume
1. Connect the DC volt meter to the JW030 and JW031 or JW011 and JW012.
  2. After the power is turned on, complete within 15 seconds to adjust RV500 (L-CH) and RV600 (R-CH) so that the bias voltage becomes  $9\text{mV} \pm 1\text{mV}$ .

**Note :** This adjustment must be completed within 15 seconds.

**Adjustment Location :**

**[ MAIN BOARD ]** (Component Side)

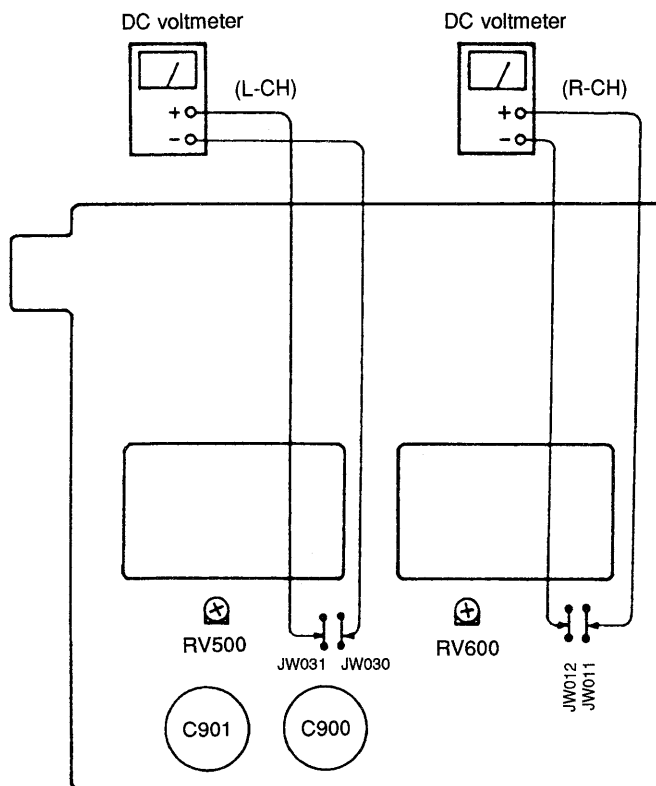

# SECTION 4 DIAGRAMS

## 4-1. CIRCUIT BOARDS LOCATION

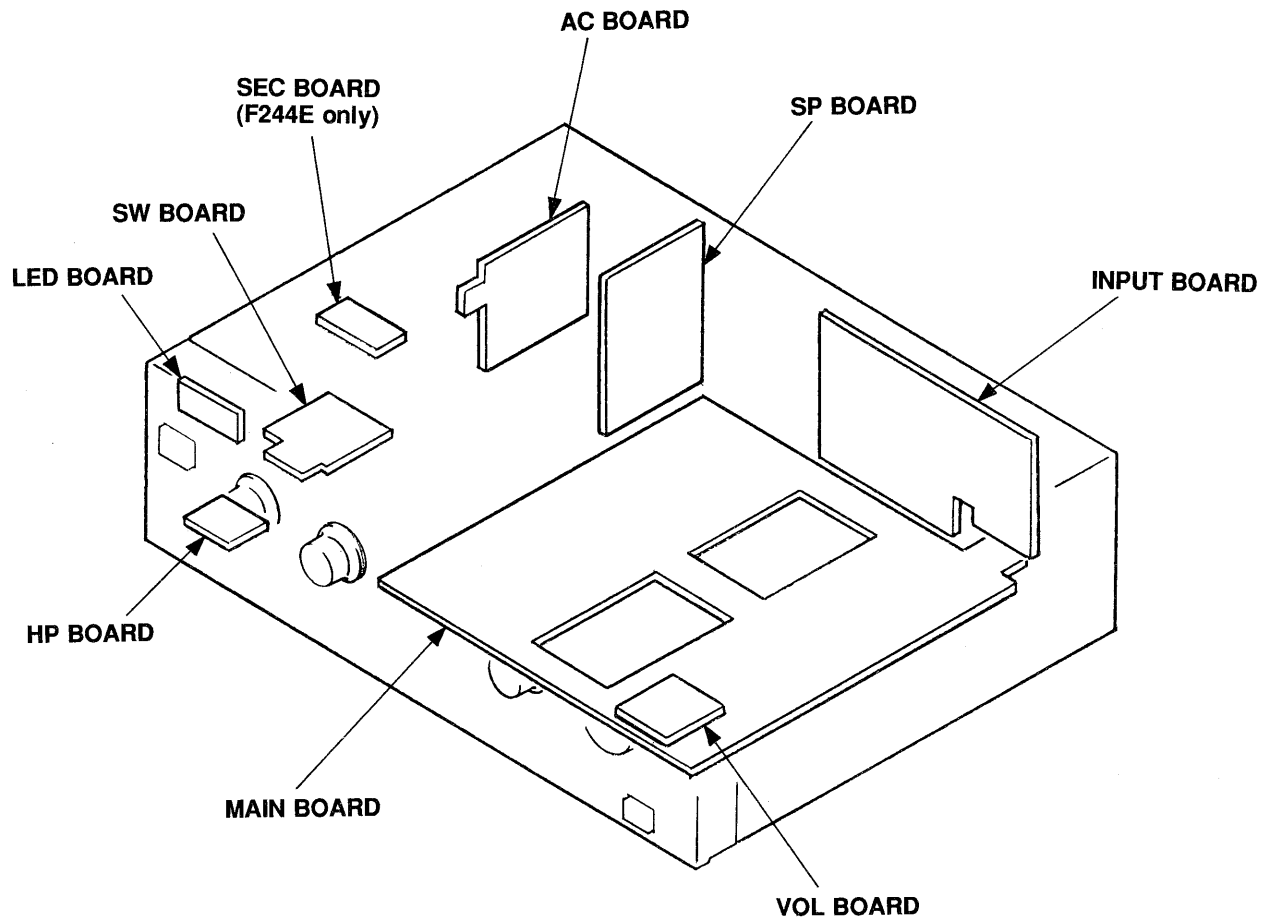

4-2. BLOCK DIAGRAM

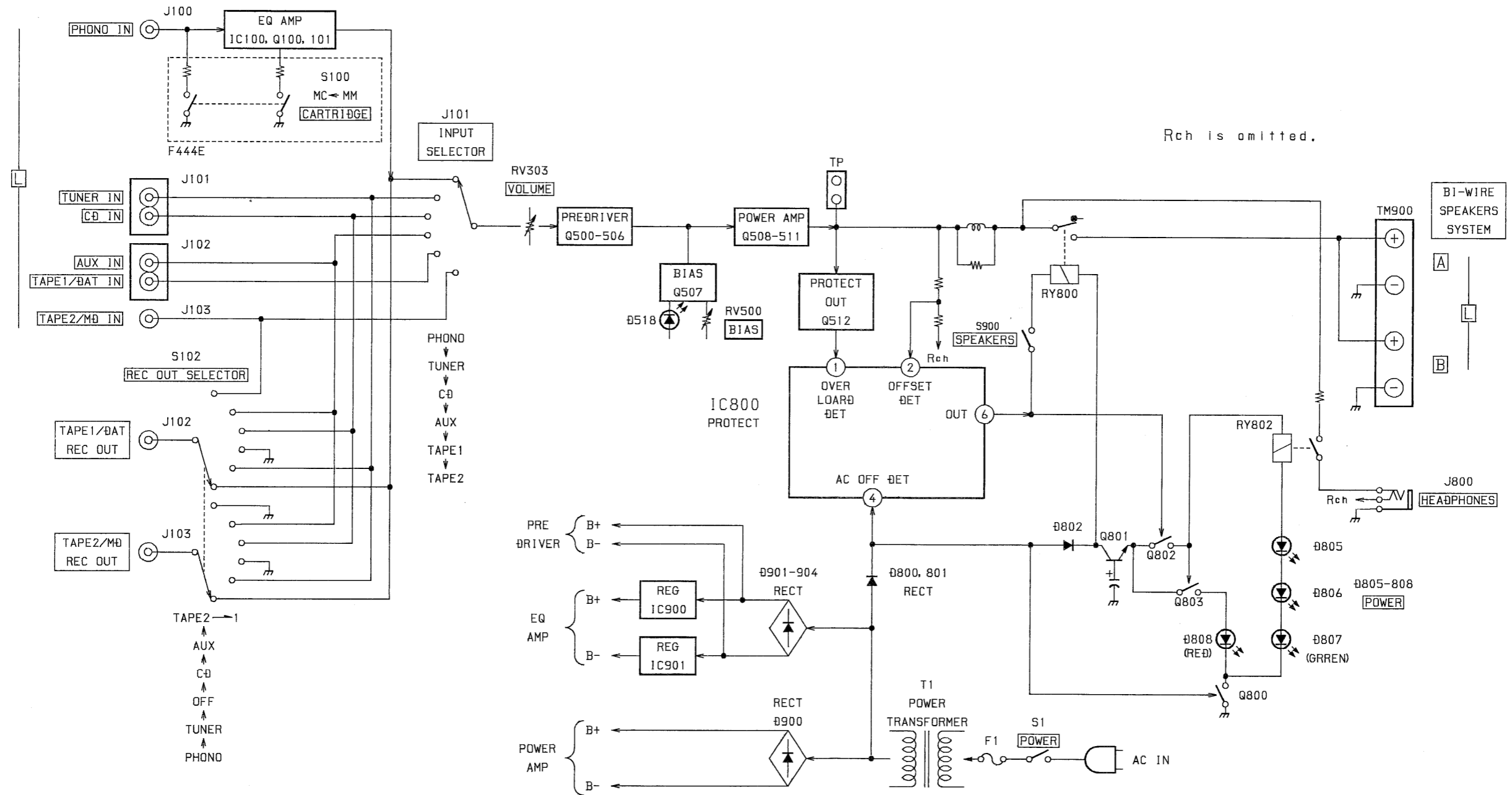

• Semiconductor Lead Layouts

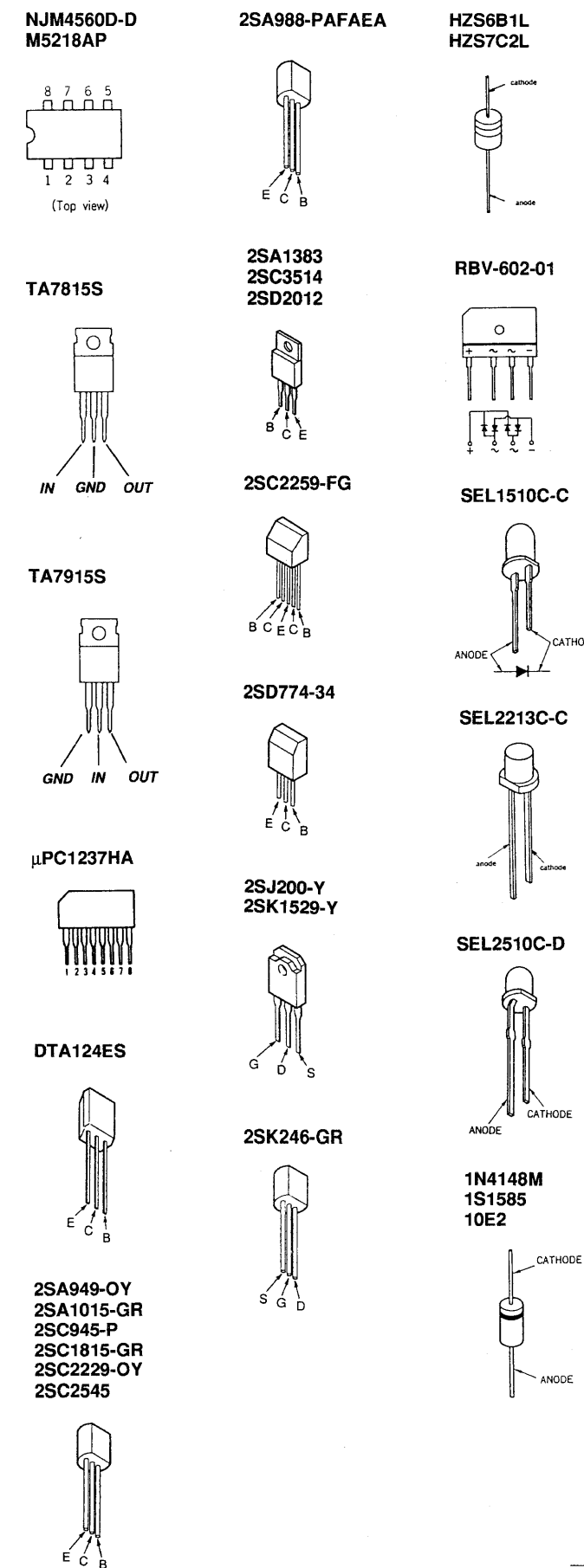

4-3. PRINTED WIRING BOARDS  
• See page 6 for Circuit Boards Location.

• Semiconductor Location

Ref. No.	Location	Ref. No.	Location
D100	A-9	IC100	B-10
D500	D-13	IC800	I-4
D501	D-11	IC900	A-8
D502	D-11	IC901	A-8
D503	E-11		
D504	E-13	Q100	B-11
D505	D-13	Q101	B-11
D506	E-13	Q200	B-11
D515	H-9	Q201	A-11
D516	H-5	Q500	D-12
D518	H-11	Q501	D-13
D600	D-5	Q502	E-12
D601	D-7	Q503	E-12
D602	D-7	Q504	D-13
D603	E-7	Q505	D-12
D604	E-5	Q506	D-11
D605	D-5	Q507	G-11
D606	E-5	Q508	H-10
D615	H-4	Q509	H-11
D616	H-4	Q510	G-10
D618	H-6	Q511	G-12
D800	J-7	Q512	I-9
D801	I-7	Q600	D-6
D802	I-6	Q601	D-5
D803	I-4	Q602	D-6
D804	J-4	Q603	E-6
D805	I-1	Q604	D-5
D806	I-1	Q605	D-6
D807	I-2	Q606	D-7
D808	I-1	Q607	G-6
D811	G-15	Q608	H-6
D812	H-15	Q609	H-7
D815	J-4	Q610	G-5
D900	I-8	Q611	H-4
D901	J-7	Q800	J-4
D902	J-7	Q801	I-6
D903	J-7	Q802	I-5
D904	J-7	Q803	I-5

Note:  
 • : parts extracted from the component side.  
 • : Pattern from the side which enable seeing.

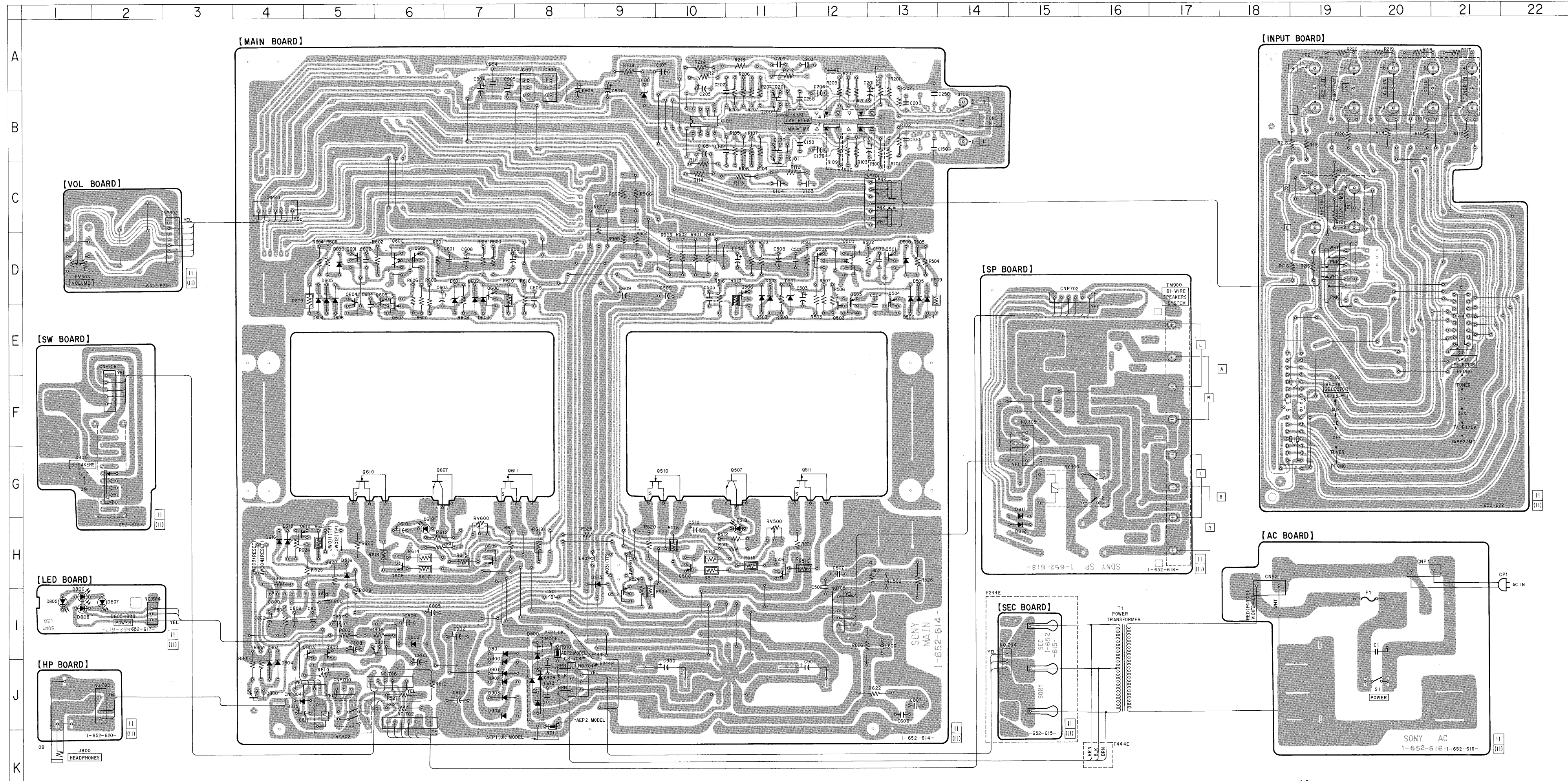



4-4. SCHEMATIC DIAGRAM

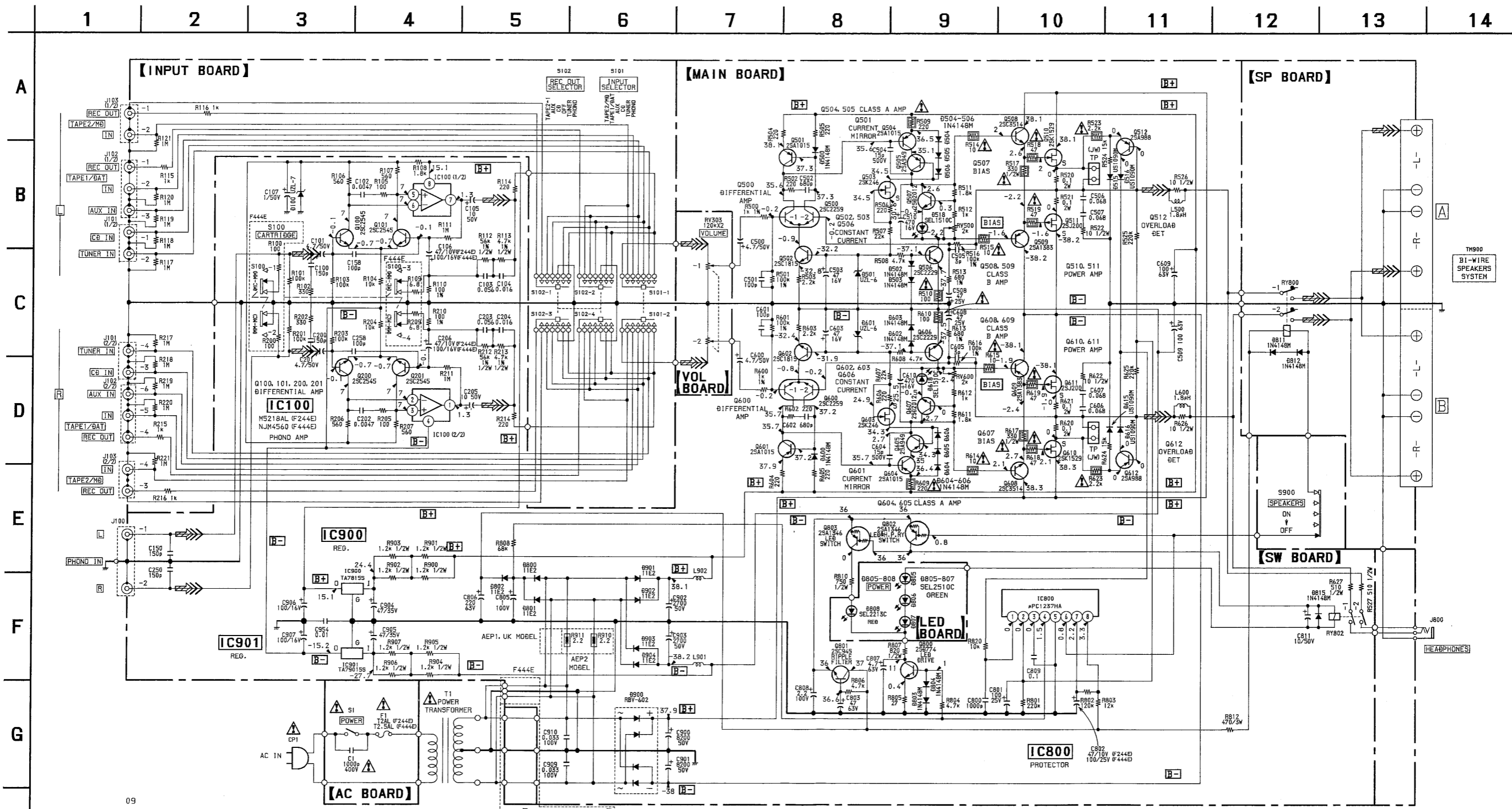

NOTE

- All capacitors are in  $\mu\text{F}$  unless otherwise noted, pF:  $\mu\text{pF}$  50W or less are not indicated except for electrolytics and tantalums.
- All resistors are in  $\Omega$  and  $1/4\text{W}$  or less unless otherwise specified.
- $\%$  : indicates tolerance.
- $\square$  : nonflammable resistor.
- $\square$  : panel designation.
- $\square+$  : B+ Line.
- $\square-$  : B- Line.
- $\square$  : adjustment for repair.
- Voltages and waveforms are dc with respect to ground under no-signal conditions.
- Voltages are taken with a VOM (Input impedance  $10\text{M}\Omega$ ). Voltage variations may be noted due to normal production tolerances.
- Signal path.

Note: The components identified by mark  $\Delta$  or dotted line with mark  $\Delta$  are critical for safety. Replace only with part number specified.

Note: There are two type of AEP models which are depend on countries. AEP2: Model for Scandinavian countries, Switzerland, Spain and Portugal. AEP1: Model for other European countries.

IC800  $\mu\text{PC1237HA}$

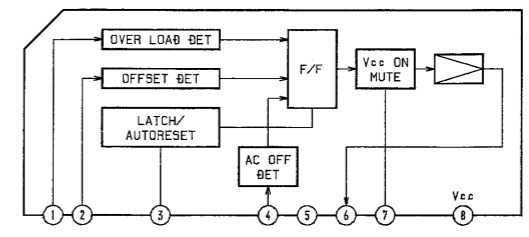

# SECTION 5 EXPLODED VIEWS

**NOTE:**

- Items marked “ \* ” are not stocked since they are seldom required for routine service. Some delay should be anticipated when ordering these items.
- -XX, -X mean standardized parts, so they may have some difference from the original one.

- The mechanical parts with no reference number in the exploded views are not supplied.
- Hardware (# mark) list and accessories and packing materials are given in the last of this parts list.

The components identified by mark  $\Delta$  or dotted line with mark  $\Delta$  are critical for safety. Replace only with part number specified.

Note:  
There are two type of AEP models which are depend on countries.  
AEP2: Model for Scandinavian countries, Sweterland, Spain and Portugal.  
AEP1: Model for other European countries.

## 5-1. CASE AND FRONT PANEL SECTION

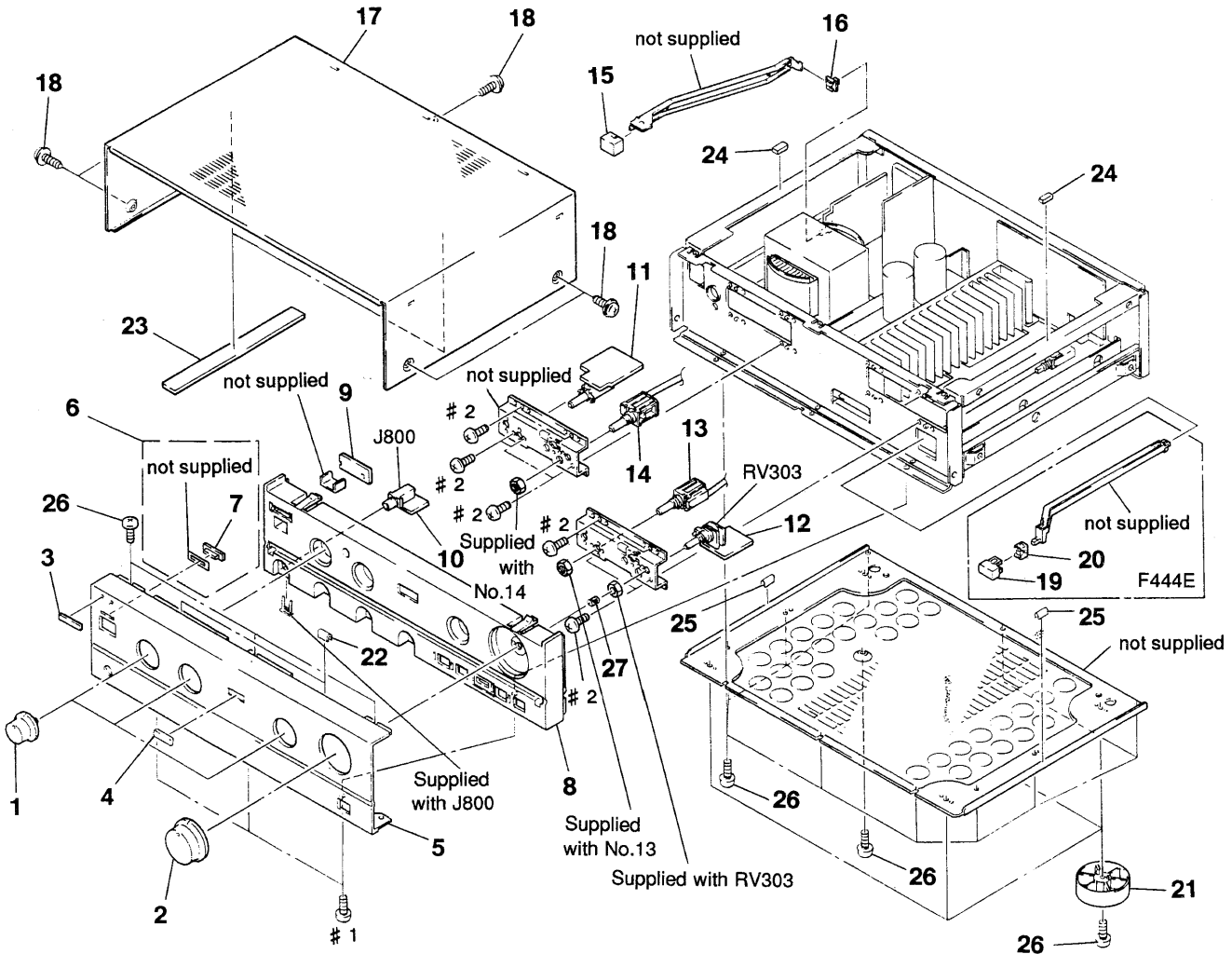

Ref. No.	Part No.	Description	Remark	Ref. No.	Part No.	Description	Remark
1	4-966-305-01	KNOB (DIA. 32)		15	4-949-281-01	BUTTON	
2	X-4944-844-1	KNOB (VOL.) ASSY		16	4-875-466-11	JOINT (F2), KNOB	
3	4-942-568-01	EMBLEM (NO. 5), SONY		* 17	4-924-920-71	CASE	
4	4-965-651-01	EMBLEM (MOS)		18	3-704-366-01	SCREW (CASE) (M3X8)	
5	4-966-304-11	PANEL, FRONT (F444E)		19	4-947-011-01	BUTTON (F) (F444E)	
5	4-966-304-21	PANEL, FRONT (F244E)		20	4-864-307-00	RING (F444E)	
6	X-4942-660-1	INDICATOR ASSY		21	X-4941-617-1	FOOT (58175) ASSY	
7	4-945-175-01	INDICATOR (PSW)		22	9-911-830-XX	SHEET, HB	
* 8	4-957-474-01	BASE, PANEL		* 23	4-961-832-01	SHEET, DAMPER	
* 9	1-652-617-11	LED BOARD		24	9-911-840-XX	CUSHION, RUBBER	
* 10	1-652-620-11	HP BOARD		25	4-952-154-01	CUSHION (PE)	
* 11	1-652-619-11	SW BOARD		26	4-967-961-01	SCREW (3X8) (SPECIAL)	
* 12	1-652-621-11	VOL BOARD		27	3-703-466-00	SPRING (6600)	
13	1-572-796-11	SWITCH, ROTARY SLIDE (INPUT SELECTOR)					
14	1-572-795-11	SWITCH, ROTARY SLIDE (REC OUT SELECTOR)					

## 5-2. CHASSIS SECTION

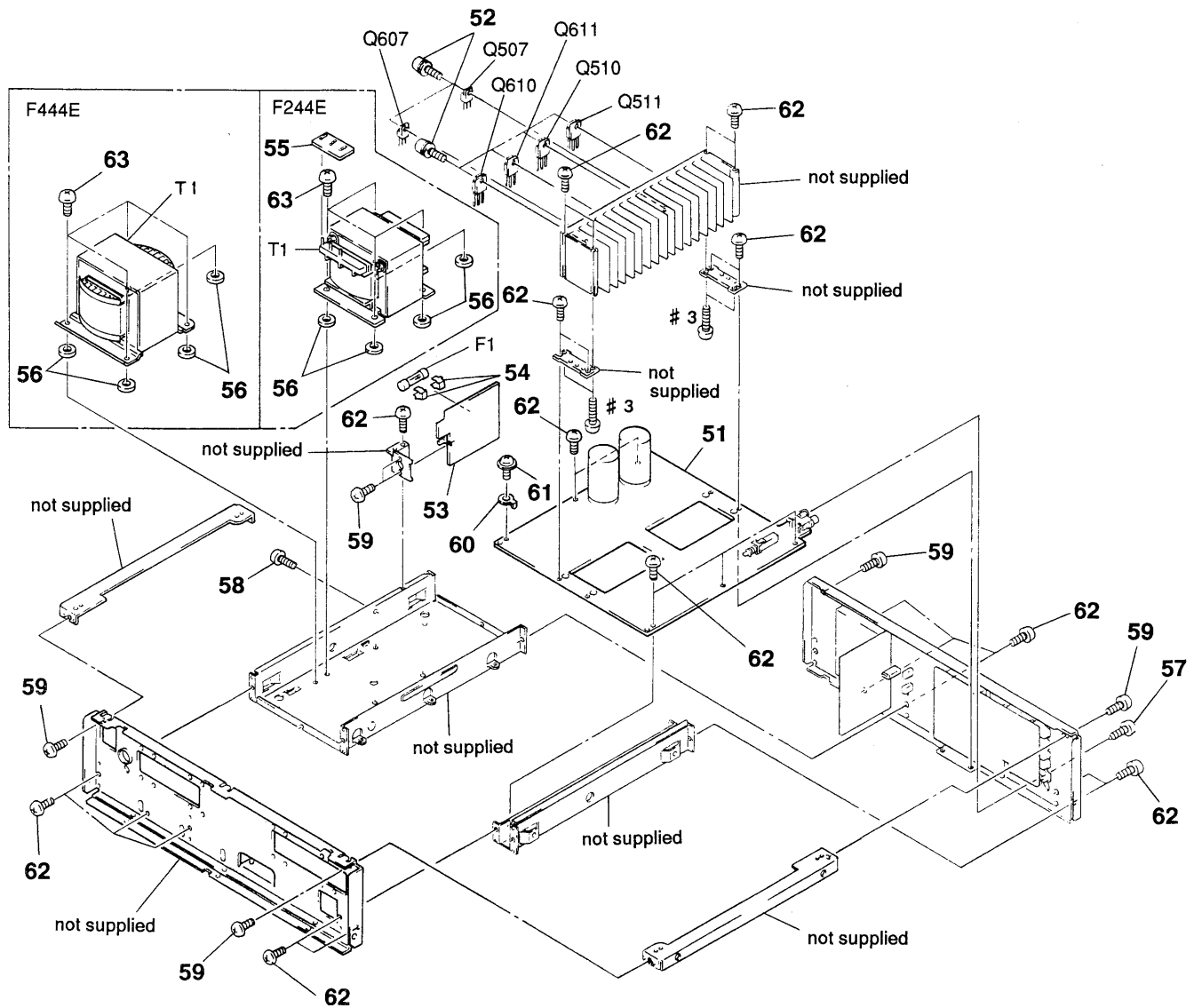

The components identified by mark  $\triangle$  or dotted line with mark  $\triangle$  are critical for safety. Replace only with part number specified.

Ref. No.	Part No.	Description	Remark	Ref. No.	Part No.	Description	Remark
* 51	A-4369-950-A	MAIN BOARD, COMPLETE (F444E:AEP1, UK)		63	4-967-960-01	SCREW (4X8)	
* 51	A-4371-171-A	MAIN BOARD, COMPLETE (F444E:AEP2)		$\triangle$ F1	1-532-203-00	FUSE (T2AL) (F244E)	
* 51	A-4371-174-A	MAIN BOARD, COMPLETE (F244E:AEP1, UK)		$\triangle$ F1	1-532-286-00	FUSE (T2, 5AL) (F444E)	
* 51	A-4371-182-A	MAIN BOARD, COMPLETE (F244E:AEP2)		Q507	8-729-209-15	TRANSISTOR 2SD2012	
52	3-905-609-11	SCREW (TRANSISTOR)		Q510	8-729-232-45	TRANSISTOR 2SK1529-Y	
* 53	1-652-616-11	AC BOARD		Q511	8-729-232-46	TRANSISTOR 2SJ200-Y	
54	1-533-233-11	HOLDER, FUSE		Q607	8-729-209-15	TRANSISTOR 2SD2012	
* 55	1-652-615-11	SEC BOARD (F244E)		Q610	8-729-232-45	TRANSISTOR 2SK1529-Y	
* 56	4-949-933-01	WASHER (K. F)		Q611	8-729-232-46	TRANSISTOR 2SJ200-Y	
57	3-704-515-41	SCREW (BV/RING)		$\triangle$ T1	1-426-892-11	TRANSFORMER, POWER (F444E:UK)	
58	4-911-049-11	SCREW (3X8)		$\triangle$ T1	1-426-893-11	TRANSFORMER, POWER (F444E:AEP)	
59	4-967-959-01	SCREW (3X6)		$\triangle$ T1	1-426-894-11	TRANSFORMER, POWER (F244E:UK)	
* 60	4-870-539-00	PLATE, GROUND		$\triangle$ T1	1-426-895-11	TRANSFORMER, POWER (F244E:AEP)	
61	3-363-099-81	SCREW (CASE3 TP2)					
62	4-967-961-01	SCREW (3X8) (SPECIAL)					

### 5-3. BACK PANEL SECTION

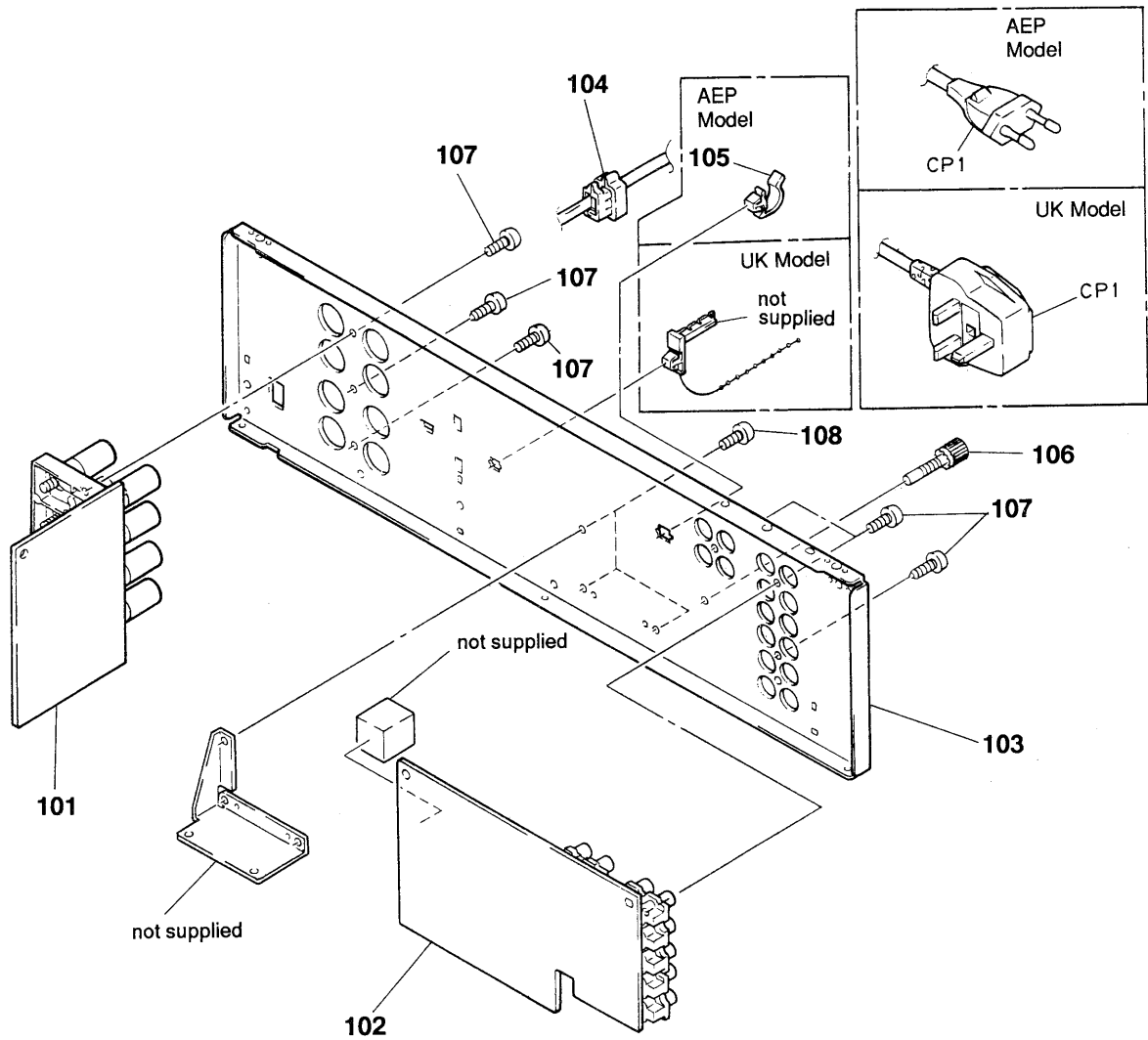

The components identified by mark  $\Delta$  or dotted line with mark  $\Delta$  are critical for safety. Replace only with part number specified.

Ref. No.	Part No.	Description	Remark	Ref. No.	Part No.	Description	Remark
* 101	1-652-618-11	SP BOARD		* 104	3-703-244-00	BUSHING (2104), CORD	
* 102	1-652-622-11	INPUT BOARD		* 105	4-949-235-01	HOOK (AEP)	
* 103	4-966-303-31	PANEL, BACK (F444E:UK)		106	4-947-010-01	SCREW, FEEDER FIXED	
* 103	4-966-303-41	PANEL, BACK (F444E:AEP1)		107	3-704-515-41	SCREW (BV/RING)	
* 103	4-966-303-51	PANEL, BACK (F444E:AEP2)		108	4-967-961-01	SCREW (3X8) (SPECIAL)	
* 103	4-966-303-61	PANEL, BACK (F244E:UK)		$\Delta$ CP1	1-575-651-11	CORD, POWER (AEP)	
* 103	4-966-303-71	PANEL, BACK (F244E:AEP1)		$\Delta$ CP1	1-696-585-21	CORD, POWER (UK)	
* 103	4-966-303-81	PANEL, BACK (F244E:AEP2)					

**AC HP INPUT**

**LED MAIN**

**SECTION 6  
ELECTRICAL PARTS LIST**

**NOTE:**

The components identified by mark  $\Delta$  or dotted line with mark  $\Delta$  are critical for safety.  
Replace only with part number specified.

When indicating parts by reference number, please include the board name.

Note:  
There are two type of AEP models which are depend on countries.  
AEP2: Model for Scandinavian countries, Swetzerland, Spain and Portugal.  
AEP1: Model for other European countries.

- Due to standardization, replacements in the parts list may be different from the parts specified in the diagrams or the components used on the set.
- Items marked "\*" are not stocked since they are seldom required for routine service. Some delay should be anticipated when ordering these items.
- -XX, -X mean standardized parts, so they may have some difference from the original one.

- RESISTORS  
All resistors are in ohms  
METAL: Metal-film resistor  
METAL OXIDE: Metal Oxide-film resistor  
F : nonflammable
- SEMICONDUCTORS  
In each case, u:  $\mu$  , for example:  
uA...:  $\mu$  A..., uPA...:  $\mu$  PA..., uPB...:  $\mu$  PB...,  
uPC...:  $\mu$  PC..., uPD...:  $\mu$  PD...
- CAPACITORS  
uF :  $\mu$  F
- COILS  
uH :  $\mu$  H
- Hardware (# mark) list and accessories and packing materials are given in the last of this parts list.

Ref. No.	Part No.	Description	Remark
*	1-652-616-11	AC BOARD *****	
	1-533-233-11	HOLDER, FUSE  < CAPACITOR >	
$\Delta$ C1	1-161-741-00	CERAMIC 0.001uF 10% 400V  < CONNECTOR >	
* CNP1	1-568-226-11	PIN, CONNECTOR 2P	
CNP2	1-564-321-00	PIN, CONNECTOR 2P  < FUSE >	
$\Delta$ F1	1-532-203-00	FUSE (T2AL) (F244E)	
$\Delta$ F1	1-532-286-00	FUSE (T2.5AL) (F444E)  < SWITCH >	
$\Delta$ S1	1-554-920-11	SWITCH, PUSH (AC POWER) (1 KEY)	
*****			
*	1-652-620-11	HP BOARD *****  < JACK >	
J800	1-507-796-71	JACK (HEADPHONES)	
*****			
*	1-652-622-11	INPUT BOARD *****  < JACK >	
* J101	1-573-142-11	JACK, PIN 4P (CD, TUNER)	
J102	1-568-978-11	JACK 6P (TAPE1/DAT)	
* J103	1-573-142-21	JACK, PIN 4P (TAPE2/MD)  < RESISTOR >	
R115	1-247-713-11	CARBON 1K 5% 1/4W F	
R116	1-247-713-11	CARBON 1K 5% 1/4W F	
R117	1-246-545-00	CARBON 1.0M 5% 1/4W	
R118	1-246-545-00	CARBON 1.0M 5% 1/4W	
R119	1-246-545-00	CARBON 1.0M 5% 1/4W	

Ref. No.	Part No.	Description	Remark
R120	1-246-545-00	CARBON 1.0M 5% 1/4W	
R121	1-246-545-00	CARBON 1.0M 5% 1/4W	
R215	1-247-713-11	CARBON 1K 5% 1/4W F	
R216	1-247-713-11	CARBON 1K 5% 1/4W F	
R217	1-246-545-00	CARBON 1.0M 5% 1/4W	
R218	1-246-545-00	CARBON 1.0M 5% 1/4W	
R219	1-246-545-00	CARBON 1.0M 5% 1/4W	
R220	1-246-545-00	CARBON 1.0M 5% 1/4W	
R221	1-246-545-00	CARBON 1.0M 5% 1/4W	
< SWITCH >			
S101	1-571-669-11	SWITCH, SLIDE (INPUT SELECTOR)	
S102	1-571-115-11	SWITCH, SLIDE (REC OUT SELECTOR)	
*****			
*	1-652-617-11	LED BOARD *****  < DIODE >	
D805	8-719-303-02	DIODE SEL2510C-D (POWER)	
D806	8-719-303-02	DIODE SEL2510C-D (POWER)	
D807	8-719-303-02	DIODE SEL2510C-D (POWER)	
D808	8-719-302-23	DIODE SEL2213C-C (POWER)	
*****			
*	A-4369-950-A	MAIN BOARD, COMPLETE (F444E:AEP1, UK) *****	
*	A-4371-171-A	MAIN BOARD, COMPLETE (F444E:AEP2) *****	
*	A-4371-174-A	MAIN BOARD, COMPLETE (F244E:AEP1, UK) *****	
*	A-4371-181-A	MAIN BOARD, COMPLETE (F244E:AEP2) *****	
< CAPACITOR >			
C100	1-164-075-11	CERAMIC 150PF 10% 50V	
C101	1-126-163-11	ELECT 4.7uF 20% 50V	
C102	1-161-377-00	CERAMIC 0.0047uF 30% 50V	
C103	1-130-492-11	MYLAR 0.056uF 5% 50V	
C104	1-137-471-11	FILM 0.016uF 5% 50V	
C105	1-126-059-11	ELECT 10uF 20% 50V	

Ref. No.	Part No.	Description	Remark			Ref. No.	Part No.	Description	Remark		
C106	1-124-122-11	ELECT	100uF	20%	50V (F444E)	C809	1-136-165-00	FILM	0.1uF	5%	50V
C106	1-126-022-11	ELECT	47uF	20%	10V (F244E)	C811	1-124-907-11	ELECT	10uF	20%	50V
C107	1-126-044-11	ELECT	1uF	20%	50V	C900	1-109-869-11	ELECT	8200uF	20%	50V (F444E)
C150	1-162-284-31	CERAMIC	150PF	10%	50V	C900	1-109-870-11	ELECT	8200uF	20%	50V (F244E)
C158	1-164-073-11	CERAMIC	100PF	10%	50V	C901	1-109-869-11	ELECT	8200uF	20%	50V (F444E)
C200	1-164-075-11	CERAMIC	150PF	10%	50V	C901	1-109-870-11	ELECT	8200uF	20%	50V (F244E)
C201	1-126-163-11	ELECT	4.7uF	20%	50V	C902	1-109-871-11	ELECT	2700uF	20%	50V
C202	1-161-377-00	CERAMIC	0.0047uF	30%	50V	C903	1-109-871-11	ELECT	2700uF	20%	50V
C203	1-130-492-11	MYLAR	0.056uF	5%	50V	C904	1-126-051-11	ELECT	47uF	20%	35V
C204	1-137-471-11	FILM	0.016uF	5%	50V	C905	1-126-051-11	ELECT	47uF	20%	35V
C205	1-126-059-11	ELECT	10uF	20%	50V	C906	1-126-023-11	ELECT	100uF	20%	16V
C206	1-124-122-11	ELECT	100uF	20%	50V (F444E)	C907	1-126-023-11	ELECT	100uF	20%	16V
C206	1-126-022-11	ELECT	47uF	20%	10V (F244E)	C909	1-106-379-12	MYLAR	0.033uF	5%	200V
C250	1-162-284-31	CERAMIC	150PF	10%	50V	C910	1-106-379-12	MYLAR	0.033uF	5%	200V
C258	1-164-073-11	CERAMIC	100PF	10%	50V	C954	1-162-306-11	CERAMIC	0.01uF	20%	16V
C500	1-126-163-11	ELECT	4.7uF	20%	50V	< CONNECTOR >					
C501	1-164-073-11	CERAMIC	100PF	10%	50V	CNP700	1-564-506-11	PLUG, CONNECTOR	3P		
C502	1-164-083-11	CERAMIC	680PF	10%	50V	CNP701	1-564-510-11	PLUG, CONNECTOR	7P		
C503	1-124-477-11	ELECT	47uF	20%	25V	* CNP704	1-564-104-00	PIN, CONNECTOR (B3P-VH)	3P (F444E)		
C504	1-102-316-00	CERAMIC	15PF	5%	500V	* CNP801	1-564-341-11	PIN, CONNECTOR	7P		
C505	1-164-039-11	CERAMIC	3PF	0.25PF	50V	* CNP804	1-564-337-00	PIN, CONNECTOR	3P		
C506	1-136-163-00	FILM	0.068uF	5%	50V	< DIODE >					
C507	1-136-163-00	FILM	0.068uF	5%	50V	D100	8-719-933-50	DIODE	HZS7C2L		
C508	1-124-910-11	ELECT	47uF	20%	50V	D500	8-719-987-63	DIODE	1N4148M		
C509	1-124-572-11	ELECT	100uF	20%	63V (F244E)	D501	8-719-933-36	DIODE	HZS6B1L		
C509	1-126-365-51	ELECT	100uF	20%	63V (F444E)	D502	8-719-987-63	DIODE	1N4148M		
C510	1-126-012-11	ELECT	470uF	20%	16V (F244E)	D503	8-719-987-63	DIODE	1N4148M		
C510	1-126-103-11	ELECT	470uF	20%	16V (F444E)	D504	8-719-987-63	DIODE	1N4148M		
C600	1-126-163-11	ELECT	4.7uF	20%	50V	D505	8-719-987-63	DIODE	1N4148M		
C601	1-164-073-11	CERAMIC	100PF	10%	50V	D506	8-719-987-63	DIODE	1N4148M		
C602	1-164-083-11	CERAMIC	680PF	10%	50V	D515	8-719-815-85	DIODE	1S1585		
C603	1-124-477-11	ELECT	47uF	20%	25V	D516	8-719-815-85	DIODE	1S1585		
C604	1-102-316-00	CERAMIC	15PF	5%	500V	D518	8-719-310-60	DIODE	SEL1510C-C		
C605	1-164-039-11	CERAMIC	3PF	0.25PF	50V	D600	8-719-987-63	DIODE	1N4148M		
C606	1-136-163-00	FILM	0.068uF	5%	50V	D601	8-719-933-36	DIODE	HZS6B1L		
C607	1-136-163-00	FILM	0.068uF	5%	50V	D602	8-719-987-63	DIODE	1N4148M		
C608	1-124-910-11	ELECT	47uF	20%	50V	D603	8-719-987-63	DIODE	1N4148M		
C609	1-124-572-11	ELECT	100uF	20%	63V (F244E)	D604	8-719-987-63	DIODE	1N4148M		
C609	1-126-365-51	ELECT	100uF	20%	63V (F444E)	D605	8-719-987-63	DIODE	1N4148M		
C610	1-126-012-11	ELECT	470uF	20%	16V (F244E)	D606	8-719-987-63	DIODE	1N4148M		
C610	1-126-103-11	ELECT	470uF	20%	16V (F444E)	D615	8-719-815-85	DIODE	1S1585		
C800	1-164-085-11	CERAMIC	0.001uF	10%	50V	D616	8-719-815-85	DIODE	1S1585		
C801	1-124-478-11	ELECT	100uF	20%	25V	D618	8-719-310-60	DIODE	SEL1510C-C		
C802	1-124-126-00	ELECT	47uF	20%	10V (F244E)	D800	8-719-200-02	DIODE	10E2		
C802	1-124-478-11	ELECT	100uF	20%	25V (F444E)	D801	8-719-200-02	DIODE	10E2		
C803	1-124-918-11	ELECT	47uF	20%	63V	D802	8-719-200-02	DIODE	10E2		
C805	1-124-791-11	ELECT	1.0uF	20%	100V	D803	8-719-987-63	DIODE	1N4148M		
C806	1-124-919-11	ELECT	220uF	20%	63V	D804	8-719-987-63	DIODE	1N4148M		
C807	1-124-927-11	ELECT	4.7uF	20%	100V						
C808	1-124-925-11	ELECT	2.2uF	20%	100V						

# MAIN

Ref. No.	Part No.	Description	Remark	Ref. No.	Part No.	Description	Remark
D815	8-719-987-63	DIODE	1N4148M	Q609	8-729-104-91	TRANSISTOR	2SA1383
D900	8-719-302-38	DIODE	RBV-602-01	Q610	8-729-232-45	TRANSISTOR	2SK1529-Y
D901	8-719-200-02	DIODE	10E2	Q611	8-729-232-46	TRANSISTOR	2SJ200-Y
D902	8-719-200-02	DIODE	10E2	Q612	8-729-140-82	TRANSISTOR	2SA988-PAFAEA
D903	8-719-200-02	DIODE	10E2	Q800	8-729-140-96	TRANSISTOR	2SD774-34
D904	8-719-200-02	DIODE	10E2	Q801	8-729-194-57	TRANSISTOR	2SC945-P
		< IC >		Q802	8-729-900-63	TRANSISTOR	DTA124ES
IC100	8-759-745-61	IC	NJM4560D-D (F444E)	Q803	8-729-900-63	TRANSISTOR	DTA124ES
IC100	8-759-634-51	IC	M5218AP (F244E)			< RESISTOR >	
IC800	8-759-111-68	IC	uPC1237HA	R100	1-247-700-11	CARBON	100 5% 1/4W F (F444E)
IC900	8-759-231-59	IC	TA7815S	R101	1-249-469-11	CARBON	100K 5% 1/4W
IC901	8-759-245-87	IC	TA7915S	R102	1-247-706-11	CARBON	330 5% 1/4W F
		< JACK >		R103	1-249-469-11	CARBON	100K 5% 1/4W
* J100	1-573-140-11	JACK, PIN 2P (PHONO)		R104	1-247-725-11	CARBON	10K 5% 1/4W
		< COIL >		R105	1-247-700-11	CARBON	100 5% 1/4W F
L500	1-420-872-00	COIL, AIR CORE	1.8uH	R106	1-247-710-11	CARBON	560 5% 1/4W
L600	1-420-872-00	COIL, AIR CORE	1.8uH	R107	1-247-710-11	CARBON	560 5% 1/4W
* L901	1-428-203-11	COIL, AIR-CORE		R108	1-247-716-11	CARBON	1.8K 5% 1/4W
* L902	1-428-203-11	COIL, AIR-CORE		R109	1-249-457-11	CARBON	6.8 5% 1/4W (F444E)
		< TRANSISTOR >		R110	1-249-899-11	CARBON	100 1% 1/4W
Q100	8-729-354-52	TRANSISTOR	2SC2545	R111	1-246-545-00	CARBON	1.0M 5% 1/4W
Q101	8-729-354-52	TRANSISTOR	2SC2545	R112	1-249-844-11	CARBON	56K 1% 1/2W
Q200	8-729-354-52	TRANSISTOR	2SC2545	R113	1-249-818-11	CARBON	4.7K 1% 1/2W
Q201	8-729-354-52	TRANSISTOR	2SC2545	R114	1-247-704-11	CARBON	220 5% 1/4W
Q500	8-729-620-17	TRANSISTOR	2SC2259-FG	R200	1-247-700-11	CARBON	100 5% 1/4W F (F444E)
Q501	8-729-201-53	TRANSISTOR	2SA1015-GR	R201	1-249-469-11	CARBON	100K 5% 1/4W
Q502	8-729-281-53	TRANSISTOR	2SC1815-GR	R202	1-247-706-11	CARBON	330 5% 1/4W F
Q503	8-729-224-62	TRANSISTOR	2SK246-GR	R203	1-249-469-11	CARBON	100K 5% 1/4W
Q504	8-729-201-53	TRANSISTOR	2SA1015-GR	R204	1-247-725-11	CARBON	10K 5% 1/4W
Q505	8-729-021-74	TRANSISTOR	2SA949-OY	R205	1-247-700-11	CARBON	100 5% 1/4W F
Q506	8-729-021-73	TRANSISTOR	2SC2229-OY	R206	1-247-710-11	CARBON	560 5% 1/4W
Q507	8-729-209-15	TRANSISTOR	2SD2012	R207	1-247-710-11	CARBON	560 5% 1/4W
Q508	8-729-104-18	TRANSISTOR	2SC3514	R209	1-249-457-11	CARBON	6.8 5% 1/4W (F444E)
Q509	8-729-104-91	TRANSISTOR	2SA1383	R210	1-249-899-11	CARBON	100 1% 1/4W
Q510	8-729-232-45	TRANSISTOR	2SK1529-Y	R211	1-246-545-00	CARBON	1.0M 5% 1/4W
Q511	8-729-232-46	TRANSISTOR	2SJ200-Y	R212	1-249-844-11	CARBON	56K 1% 1/2W
Q512	8-729-140-82	TRANSISTOR	2SA988-PAFAEA	R213	1-249-818-11	CARBON	4.7K 1% 1/2W
Q600	8-729-620-17	TRANSISTOR	2SC2259-FG	R214	1-247-704-11	CARBON	220 5% 1/4W
Q601	8-729-201-53	TRANSISTOR	2SA1015-GR	R500	1-249-923-11	CARBON	1K 1% 1/4W
Q602	8-729-281-53	TRANSISTOR	2SC1815-GR	R501	1-249-971-11	CARBON	100K 1% 1/4W
Q603	8-729-224-62	TRANSISTOR	2SK246-GR	R502	1-247-704-11	CARBON	220 5% 1/4W
Q604	8-729-201-53	TRANSISTOR	2SA1015-GR	R503	1-247-717-11	CARBON	2.2K 5% 1/4W F
Q605	8-729-021-74	TRANSISTOR	2SA949-OY	R504	1-247-704-11	CARBON	220 5% 1/4W
Q606	8-729-021-73	TRANSISTOR	2SC2229-OY	R505	1-247-704-11	CARBON	220 5% 1/4W
Q607	8-729-209-15	TRANSISTOR	2SD2012	R506	1-247-704-11	CARBON	220 5% 1/4W
Q608	8-729-104-18	TRANSISTOR	2SC3514	R507	1-249-462-11	CARBON	22K 5% 1/4W
				R508	1-247-721-11	CARBON	4.7K 5% 1/4W
				△R509	1-247-704-11	CARBON	220 5% 1/4W F
				△R510	1-247-700-11	CARBON	100 5% 1/4W F

The components identified by mark  $\triangle$  or dotted line with mark  $\triangle$  are critical for safety. Replace only with part number specified.

Ref. No.	Part No.	Description	Remark	Ref. No.	Part No.	Description	Remark
R511	1-247-716-11	CARBON	1.8K 5% 1/4W	R806	1-247-721-11	CARBON	4.7K 5% 1/4W
R512	1-247-713-11	CARBON	1K 5% 1/4W F	R807	1-247-751-11	CARBON	820 5% 1/2W
R513	1-249-919-11	CARBON	680 1% 1/4W	R808	1-249-467-11	CARBON	68K 5% 1/4W
△R514	1-247-688-11	CARBON	10 5% 1/4W F	R810	1-247-237-00	CARBON	750 5% 1/2W
△R515	1-247-688-11	CARBON	10 5% 1/4W F	R812	1-215-915-11	METAL OXIDE	470 5% 3W F
R516	1-249-971-11	CARBON	100K 1% 1/4W	R820	1-247-725-11	CARBON	10K 5% 1/4W
△R517	1-247-745-11	CARBON	330 5% 1/2W F	R900	1-247-753-11	CARBON	1.2K 5% 1/2W
△R518	1-247-696-11	CARBON	47 5% 1/4W F	R901	1-247-753-11	CARBON	1.2K 5% 1/2W
△R519	1-247-696-11	CARBON	47 5% 1/4W F	R902	1-247-753-11	CARBON	1.2K 5% 1/2W
R520	1-217-611-00	METAL PLATE	0.1	R903	1-247-753-11	CARBON	1.2K 5% 1/2W
R521	1-217-611-00	METAL PLATE	0.1	R904	1-247-753-11	CARBON	1.2K 5% 1/2W
R522	1-247-727-11	CARBON	10 5% 1/2W	R905	1-247-753-11	CARBON	1.2K 5% 1/2W
△R523	1-247-717-11	CARBON	2.2K 5% 1/4W F	R906	1-247-753-11	CARBON	1.2K 5% 1/2W
R524	1-249-460-11	CARBON	15K 5% 1/4W	R907	1-247-753-11	CARBON	1.2K 5% 1/2W
R525	1-247-887-00	CARBON	220K 5% 1/4W	R910	1-806-882-11	THERMISTOR, POSITIVE	2.2 (AEP2)
R526	1-247-727-11	CARBON	10 5% 1/2W	R911	1-806-882-11	THERMISTOR, POSITIVE	2.2 (AEP2)
R527	1-247-748-11	CARBON	510 5% 1/2W			< VARIABLE RESISTOR >	
R600	1-249-923-11	CARBON	1K 1% 1/4W	RV500	1-237-457-21	RES, ADJ, CARBON	2K
R601	1-249-971-11	CARBON	100K 1% 1/4W	RV600	1-237-457-21	RES, ADJ, CARBON	2K
R602	1-247-704-11	CARBON	220 5% 1/4W			< RELAY >	
R603	1-247-717-11	CARBON	2.2K 5% 1/4W F	RY802	1-515-787-21	RELAY	
R604	1-247-704-11	CARBON	220 5% 1/4W			< SWITCH >	
R605	1-247-704-11	CARBON	220 5% 1/4W	S100	1-571-111-11	SWITCH, PUSH (1 KEY)	(F444E)
R606	1-247-704-11	CARBON	220 5% 1/4W			*****	
R607	1-249-462-11	CARBON	22K 5% 1/4W	*	1-652-615-11	SEC BOARD (F244E)	*****
R608	1-247-721-11	CARBON	4.7K 5% 1/4W			*****	
△R609	1-247-704-11	CARBON	220 5% 1/4W F			*****	
△R610	1-247-700-11	CARBON	100 5% 1/4W F	*	1-652-618-11	SP BOARD	*****
R611	1-247-716-11	CARBON	1.8K 5% 1/4W			< CONNECTOR >	
R612	1-247-713-11	CARBON	1K 5% 1/4W F	* CNP702	1-564-509-11	PLUG, CONNECTOR	6P
R613	1-249-919-11	CARBON	680 1% 1/4W			< DIODE >	
△R614	1-247-688-11	CARBON	10 5% 1/4W F	D811	8-719-987-63	DIODE	IN4148M
△R615	1-247-688-11	CARBON	10 5% 1/4W F	D812	8-719-987-63	DIODE	IN4148M
R616	1-249-971-11	CARBON	100K 1% 1/4W			< RELAY >	
△R617	1-247-745-11	CARBON	330 5% 1/2W F	RY800	1-515-501-00	RELAY	
△R618	1-247-696-11	CARBON	47 5% 1/4W F			< TERMINAL >	
△R619	1-247-696-11	CARBON	47 5% 1/4W F	TM900	1-537-227-11	TERMINAL BOARD (SPEAKERS)	(AEP2)
R620	1-217-611-00	METAL PLATE	0.1	TM900	1-537-228-11	TERMINAL BOARD (SPEAKERS)	(AEP1, UK)
R621	1-217-611-00	METAL PLATE	0.1				
R622	1-247-727-11	CARBON	10 5% 1/2W				
△R623	1-247-717-11	CARBON	2.2K 5% 1/4W F				
R624	1-249-460-11	CARBON	15K 5% 1/4W				
R625	1-247-887-00	CARBON	220K 5% 1/4W				
R626	1-247-727-11	CARBON	10 5% 1/2W				
R627	1-247-748-11	CARBON	510 5% 1/2W				
R801	1-247-887-00	CARBON	220K 5% 1/4W				
R802	1-247-881-00	CARBON	120K 5% 1/4W				
R803	1-249-459-11	CARBON	12K 5% 1/4W				
R804	1-247-721-11	CARBON	4.7K 5% 1/4W				
R805	1-247-693-11	CARBON	27 5% 1/4W				

The components identified by mark △ or dotted line with mark △ are critical for safety. Replace only with part number specified.



**SW** **VOL**

Ref.No.	Part No.	Description	Remark
*****			
*	1-652-619-11	SW BOARD ***** < CONNECTOR >	
* CNP706	1-564-508-11	PLUG, CONNECTOR 5P  < SWITCH >	
S900	1-762-006-11	SWITCH, ROTARY SLIDE (SPEAKERS)	
*****			
*	1-652-621-11	VOL BOARD ***** < CONNECTOR >	
* CNP802	1-564-341-11	PIN, CONNECTOR 7P  < VARIABLE RESISTOR >	
RV303	1-241-557-11	RES, VAR, CARBON 120K/120K (VOLUME)	
*****			
MISCELLANEOUS *****			
13	1-572-796-11	SWITCH, ROTARY SLIDE (INPUT SELECTOR)	
14	1-572-795-11	SWITCH, ROTARY SLIDE (REC OUT SELECTOR)	
△CP1	1-575-651-11	CORD, POWER (AEP)	
△CP1	1-696-585-21	CORD, POWER (UK)	
△F1	1-532-203-00	FUSE (T2AL) (F244E)	
△F1	1-532-286-00	FUSE (T2.5AL) (F444E)	
Q507	8-729-209-15	TRANSISTOR 2SD2012	
Q510	8-729-232-45	TRANSISTOR 2SK1529-Y	
Q511	8-729-232-46	TRANSISTOR 2SJ200-Y	
Q607	8-729-209-15	TRANSISTOR 2SD2012	
Q610	8-729-232-45	TRANSISTOR 2SK1529-Y	
Q611	8-729-232-46	TRANSISTOR 2SJ200-Y	
△T1	1-426-892-11	TRANSFORMER, POWER (F444E:UK)	
△T1	1-426-893-11	TRANSFORMER, POWER (F444E:AEP)	
△T1	1-426-894-11	TRANSFORMER, POWER (F244E:UK)	
△T1	1-426-895-11	TRANSFORMER, POWER (F244E:AEP)	
*****			

Ref.No.	Part No.	Description	Remark
ACCESSORIES & PACKING MATERIALS *****			
	3-759-010-11	MANUAL, INSTRUCTION (ENGLISH, SWEDISH, PORTUGUESE, DANISH, FINNISH)	
*	4-931-985-01	CUSHION	
*	4-966-658-01	INDIVIDUAL CARTON (F444E)	
*	4-966-659-01	INDIVIDUAL CARTON (F244E)	
*****			
***** HARDWARE LIST *****			
#1	7-685-646-79	SCREW +BVTP 3X8 TYPE2 N-S	
#2	7-682-547-09	SCREW +BVTT 3X6 (S)	
#3	7-685-647-79	SCREW +BVTP 3X10 TYPE2 IT-3	

The components identified by mark △ or dotted line with mark △ are critical for safety. Replace only with part number specified.