

TA-F450D/F450ESD

SERVICE MANUAL

AEP Model
E Model
 TA-F450D
UK Model
 TA-F450ESD



Photo: TA-F450D

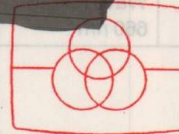

Free service manuals
 Gratis schema's
 Digitized by

SPECIFICATIONS

www.freeservicemanuals.info

Amplifier section

Continuous RMS power output (both channels driven simultaneously)

AEP, UK, West Germany model
 at 1 kHz
 110 W + 110 W (0.7% THD, 4 ohms)
 at 20 Hz – 20 kHz
 80 W + 80 W (0.008% THD, 4 ohms)

E model
 at 20 Hz – 20 kHz
 120 W + 120 W (0.008% THD, 8 ohms)

Music power output (E model)

440 W

Power bandwidth (IHF)

AEP, UK, West Germany model
 7 Hz – 35 kHz (4 ohms, 40 watts)
 E model
 7 Hz – 35 kHz (8 ohms, 60 watts)

Dynamic headroom

1.6 dB ('78 IHF)

Intermodulation (IM) distortion (60 Hz : 7 kHz = 4 : 1)

Less than 0.008% at rated output

Frequency response

PHONO: RIAA equalization curve ± 0.5 dB
 TUNER, CD, VIDEO/AUX, TAPE:
 7 Hz – 100 kHz ± 3 dB

Residual noise AEP, UK, West Germany model

Less than 200 μ V (4 ohms, network A)

E model

Less than 200 μ V (8 ohms, network A)

Damping factor 50 (8 ohms, 1 kHz)

Input

Input jack	Jack type	Sensitivity	Impedance	S/N (weighting network, input level)	
PHONO	MM	Phono	2.5 mV	50 kilohms	88 dB 86 dB* (A, 2.5 mV)
	MC	Phono	170 μ V	100 ohms	68 dB 75 dB* (A, 170 μ V)
TUNER CD VIDEO/AUX TAPE	Phono	150 mV	50 kilohms	100 dB 88 dB* (150 mV)	

*'78 IHF

Output

REC OUT	Phono jacks	Voltage 150 mV Impedance 1 kilohm
SPEAKER	—	Accepts speakers of 4 – 16 ohms (AEP, UK, West Germany model) or 8 – 16 ohms (E model)
HEAD-PHONES	Stereo phone jack	Accepts low and high impedance headphones.



INTEGRATED STEREO AMPLIFIER
SONY

Tone controls

	Response	Turnover frequency
BASS	±10 dB (100 Hz)	500 Hz
TREBLE	±10 dB (15 kHz)	3 kHz

Loudness (Attenuation 30 dB)

- + 6 dB (100 Hz)
- + 3 dB (10 kHz)

Subsonic filter 6 dB/octave, attenuation below 15 Hz

Converter section

Digital COAXIAL inputs (phono jacks)	Input level 0.5 Vp-p	Impedance 75 ohms
Digital COAXIAL output (phono jack)	Output level 0.5 Vp-p	Impedance 75 ohms
Digital OPTICAL input (optical connector)	Input level -18 dBm Wave length 660 nm	—

Number of channels

2 (stereo)

Frequency response



5 Hz – 20 kHz, ±0.8 dB
(Input digital signal sampling freq. 44.1 kHz)

Harmonic distortion

Less than 0.003% at 1 kHz
(Input digital signal sampling freq. 44.1 kHz)
More than 107 dB
(Input digital signal sampling freq. 44.1 kHz)

Dynamic range

SAFETY-RELATED COMPONENT WARNING!!

COMPONENTS IDENTIFIED BY MARK  OR DOTTED LINE WITH MARK  ON THE SCHEMATIC DIAGRAMS AND IN THE PARTS LIST ARE CRITICAL TO SAFE OPERATION. REPLACE THESE COMPONENTS WITH SONY PARTS WHOSE PART NUMBERS APPEAR AS SHOWN IN THIS MANUAL OR IN SUPPLEMENTS PUBLISHED BY SONY.

REC OUT	Phono jacks	Voltage 180 mV Impedance 1 kilohm
SPEAKER	—	Accepts speakers of 4 – 16 ohms (AEP, UK, West Germany model) or 8 – 16 ohms (E model)
HEAD PHONES	Stereo phone-jack	Accepts low and high impedance headphones.

General System

Preamplifier: Low-noise, high-gain equalizer amplifier
Power amplifier: Pure-complementary SEPP OCL power amplifier with all stages directly coupled

Power requirements

UK model: 240 V AC, 50 Hz
AEP, West Germany model: 220 V AC, 50 Hz
E model: 120 V, 220 V or 240 V
AC adjustable, 50/60 Hz

Power consumption

UK model: 440 W
AEP, West Germany model: 180 W
E model: 205 W

AC outlets

AEP, UK, West Germany model:
1 unswitched, 100 watts max.
E model:
2 switched, total 100 watts max.
1 unswitched, 100 watts max.

Dimensions

Approx. 430 x 130 x 365 mm (w/h/d)
(17 x 5 1/8 x 14 3/8 inches)

Including projecting parts and controls

Weight

Approx. 8.1 kg (17 lb 14 oz)

Supplied accessory

Optical cable (1)

CONTENTS

Section	Title	Page
Specifications		1
Model Identification		3
SECTION 1. GENERAL		
	Location and Function of Controls	3
SECTION 2. DIAGRAMS		
2-1.	Semiconductor Lead Layouts	4
2-2.	Circuit Boards Location	4
	IC Block Diagram	5
2-3.	BLOCK DIAGRAM	6
2-4.	Printed Wiring Boards (MAIN Board)	8
2-5.	Schematic Diagram (MAIN Board)	13
2-6.	Printed Wiring Boards (DAS Board)	16
2-7.	Schematic Diagram (DAS Board)	19
SECTION 3. EXPLODED VIEWS		21
SECTION 4. ELECTRICAL PARTS LIST		25

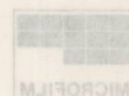

SECTION 2
DIAGRAMS

2-2. CIRCUIT BOARDS LOCATION

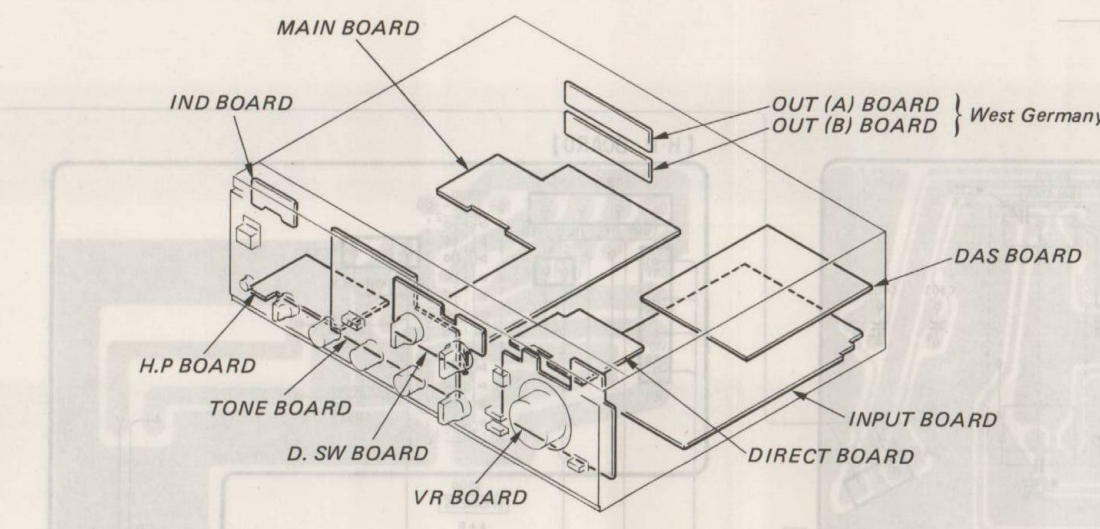

DESCRIPTION ON IC904 (YM3623B)

Pin No.	Name	I/O	FUNCTION
1	VDD1		System power supply pin. (+5V)
2	ADJ	I	Pin for adjustment of VCO frequency. No connected.
3	VCO	I/O	Pin for external capacitor of VCO.
4	VSS2		Grounding pin of VCO. Ground it together with pin (14). (Pins (4) and (14) are not connected inside.)
5	XO	O	Pin for X'tal vibrator. (16.9344 MHz ~ 20 MHz)
6	XI	I	Pin for X'tal vibrator or for an external clock signal input.
7	KMODE	I(PU)	'H': With the input at DIN (pin (24)) PLL is actuated, without it system operates with XI clock. 'L': System operates with XI clock not related with DIN input. (WAIT state)
8	φA	O	When XI clock is used, outputs XI frequency signal and when PLL operates, the signal frequency from this pin varies according to the transfer rate of DIN input data. If PLL is locked, the frequency will be Fs (input) x 384.
9	φB	O	Outputs 1/3-demultiplied signal of φA frequency. When PLL operates, signal frequency varies according to the transfer rate of DIN input data. If PLL is locked, the frequency will be Fs (input) x 128.
10	T1	I(PU)	Pin for test. No connected.
11	T2	I(PU)	Pin for test. No connected.
12	BCO	O	Bit-clock output pin for the signal from DO.
13	SYNC	O	Periodic signal output pin for the signal from DO.
14	VSS1	O	System ground. (0V)
15	L/R	O	L/R latch signal of DO output. 'H': L-channel data is output from DO pin. 'L': R-channel data is output from DO pin.
16	DEF	O	DE-EMPHASIS signal detected from user's bits. 'H': Input data is emphasized. 'L': Input data is not emphasized.
17	DO	O	Pin for 16-bit audio data output.
18	WC	O	Word-clock output pin for DO output.
19	DIGR	O	Pin for L-channel de-gitch signal output.
20	DIGL	O	Pin for R-channel de-gitch signal output.
21	ERR	O	'H': Parity error, or system is operated with XI clock. 'L': No error.
22	SEL	I(PU)	Mode select pin.
23	S1	O	Mode select pin.
24	S2	O	Mode select pin.
25	SCK	O	Pin for bit-clock for SUBCORD output.
26	SSYNC	O	Pin for synchronization signal for SUBCORD output.
27	SDO	O	Pin for SUBCORD data output.
28	DIN	I(PU)	Data input pin. (EIAJ format signal is applied.)

Note: Pins marked with (PU) are pulled up inside the LSI.

IC BLOCK DIAGRAM

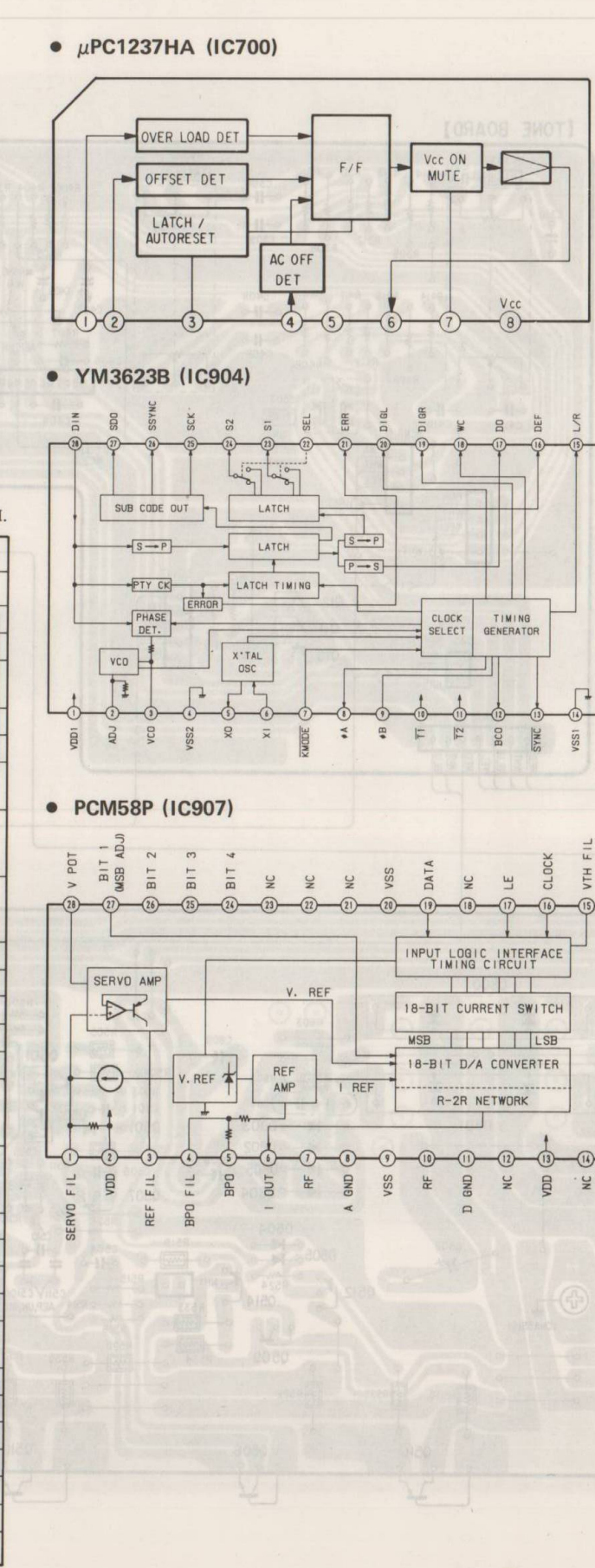

2-3. BLOCK DIAGRAM

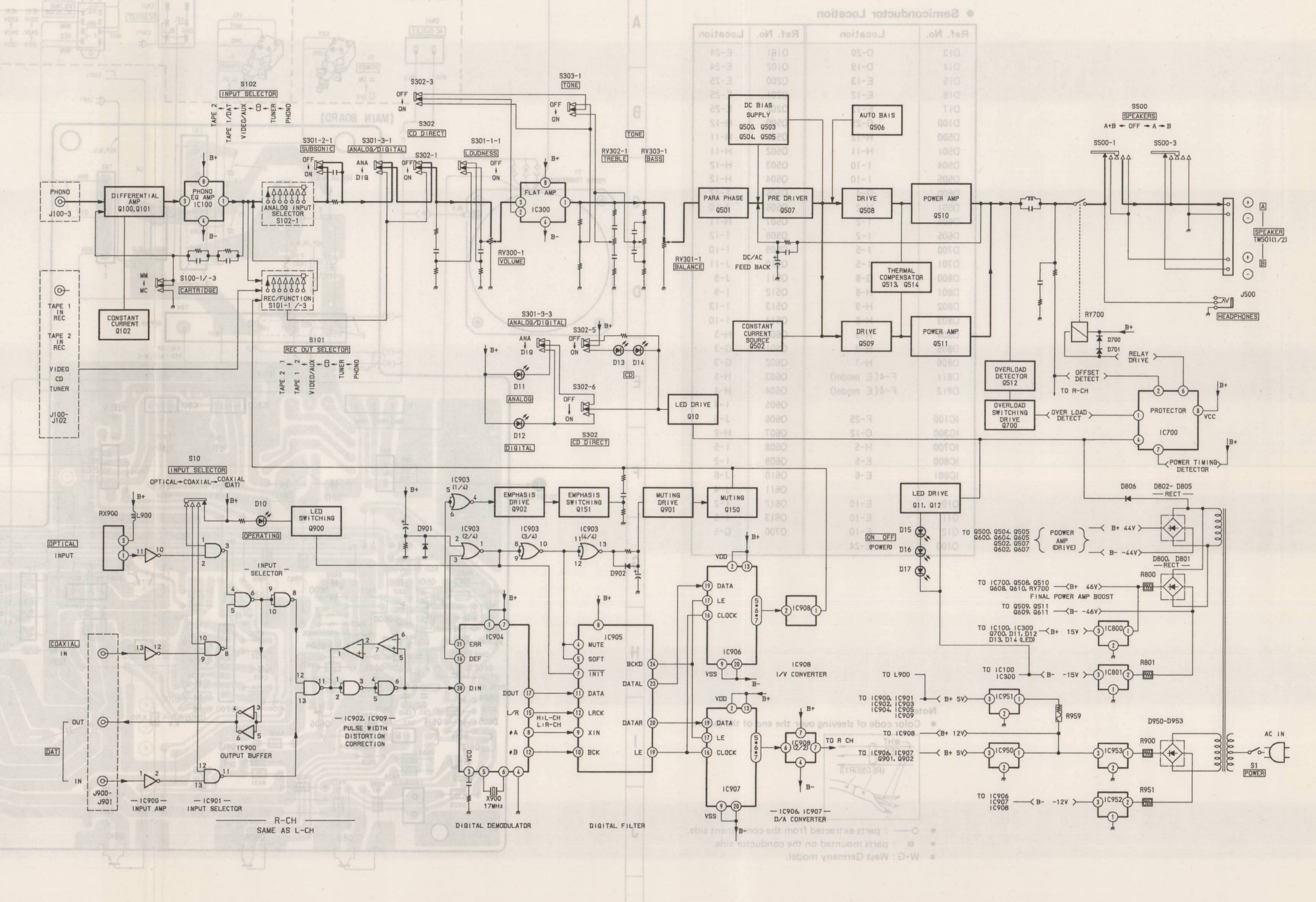

MODEL IDENTIFICATION
- Specification Label -

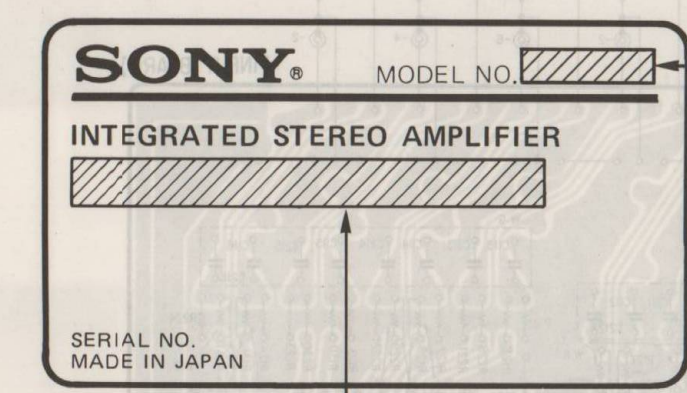

AEP, West Germany Model: AC: 220 V ~ 50/60 Hz 180 W
UK Model: AC: 240 V ~ 50/60 Hz 440 W
E Model: AC: 120/220/240 V ~ 50/60 Hz 205 W

SECTION 1
GENERAL

LOCATION AND FUNCTION OF CONTROLS

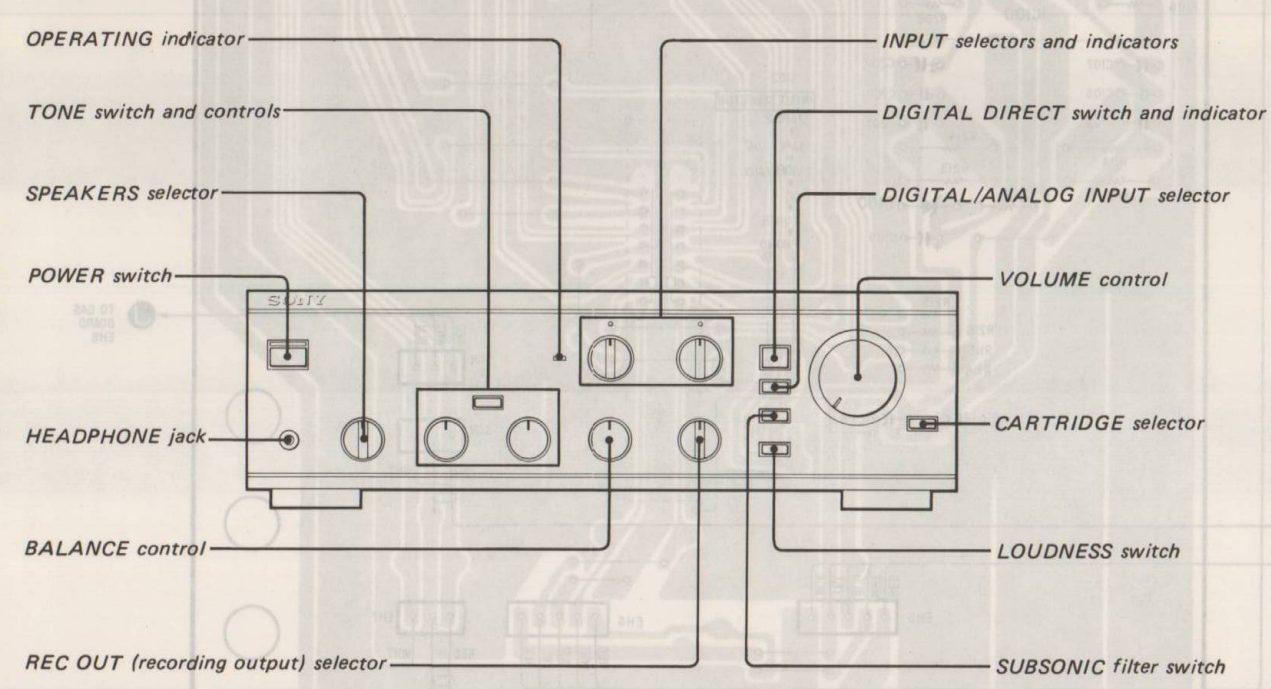

2-1. Semiconductor Lead Layouts

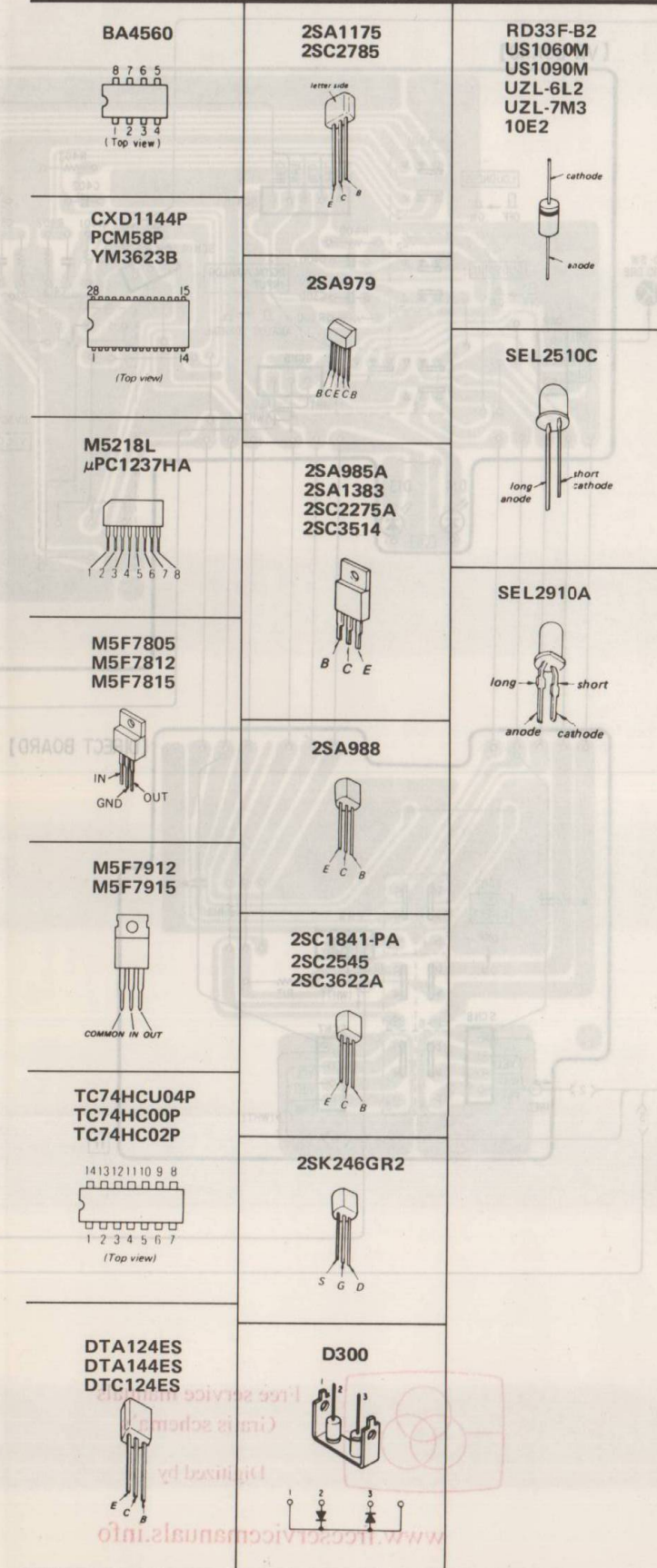

2-4. PRINTED WIRING BOARDS (MAIN BOARD)

● Semiconductor Location

Ref. No.	Location	Ref. No.	Location
D13	D-20	Q101	E-24
D14	D-19	Q102	E-24
D15	E-13	Q200	E-25
D16	E-12	Q201	E-25
D17	E-12	Q202	E-25
D100	G-25	Q500	H-12
D500	H-12	Q501	H-11
D501	H-11	Q502	H-11
D504	I-10	Q503	H-12
D505	I-10	Q504	H-12
D600	G-4	Q505	I-12
D601	H-2	Q506	J-10
D604	I-2	Q507	H-11
D605	I-2	Q508	I-12
D700	I-5	Q509	I-10
D701	I-5	Q510	J-11
D800	G-8	Q511	J-9
D801	H-8	Q512	I-9
D802	H-9	Q513	I-13
D803	H-9	Q514	I-10
D804	H-9	Q600	H-3
D805	H-9	Q601	G-3
D806	H-7	Q602	G-3
D811	F-4 (E model)	Q603	H-3
D812	F-4 (E model)	Q604	H-4
		Q605	I-4
		Q606	J-5
		Q607	H-2
		Q608	I-5
		Q609	I-2
		Q610	J-6
		Q611	J-4
		Q612	I-2
		Q613	I-5
		Q700	G-5
IC100	F-25		
IC300	C-12		
IC700	H-5		
IC800	E-5		
IC801	E-6		
Q10	E-10		
Q11	E-10		
Q12	E-10		
Q100	E-24		

Note:
 ● Color code of sleeving over the end of the jacket.
 ○ : parts extracted from the component side.
 ■ : parts mounted on the conductor side.
 W-G : West Germany model.

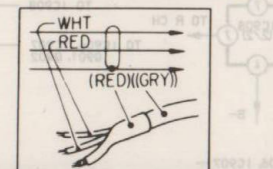
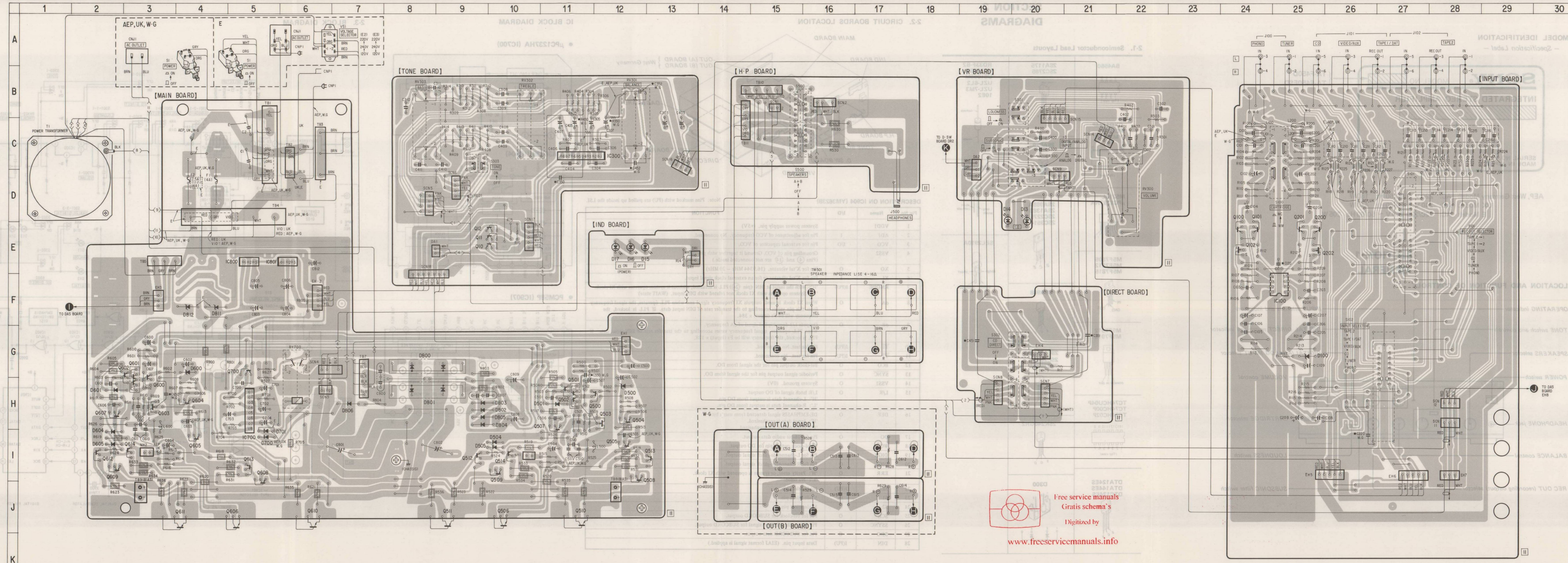
Free service manuals
 Gratis schema's
 Digitized by
www.freeservicemanuals.info

2-5. SCHEMATIC DIAGRAM (MAIN BOARD)

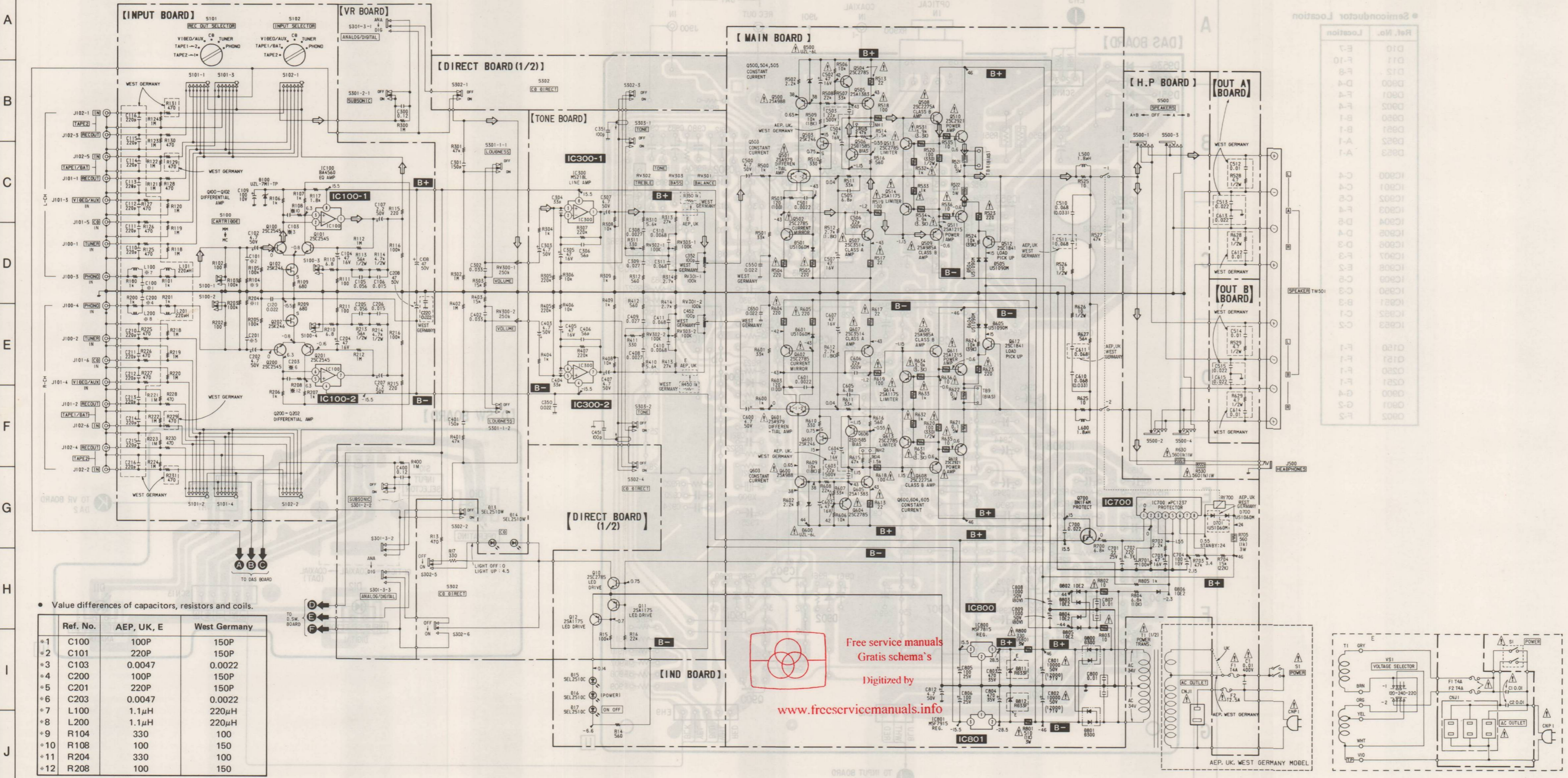

• Value differences of capacitors, resistors and coils.

Ref. No.	AEP, UK, E	West Germany	
*1	C100	100P	150P
*2	C101	220P	150P
*3	C103	0.0047	0.0022
*4	C200	100P	150P
*5	C201	220P	150P
*6	C203	0.0047	0.0022
*7	L100	1.1μH	220μH
*8	L200	1.1μH	220μH
*9	R104	330	100
*10	R108	100	150
*11	R204	330	100
*12	R208	100	150

Note: All capacitors are in μF unless otherwise noted. pF: μF 50WV or less are not indicated except for electrolytics and tantalums. All resistors are in Ω and 1/4W or less unless otherwise specified. ⚡: nonflammable resistor. ⚡: audible resistor. Voltages are dc with respect to ground under no-signal condition. Voltages are taken with a VOM (50 kΩ/V). Voltage variations may be noted due to normal production tolerances. Waveforms are taken with an oscilloscope. Voltage variations may be noted due to normal production tolerances.

Note: All capacitors are in μF unless otherwise noted. pF: μF 50WV or less are not indicated except for electrolytics and tantalums. All resistors are in Ω and 1/4W or less unless otherwise specified. ⚡: nonflammable resistor. ⚡: audible resistor. Voltages are dc with respect to ground under no-signal condition. Voltages are taken with a VOM (50 kΩ/V). Voltage variations may be noted due to normal production tolerances. Waveforms are taken with an oscilloscope. Voltage variations may be noted due to normal production tolerances.

Note: The components identified by mark ⚡ or dotted line with mark ⚡ are critical for safety. Replace only with part number specified.

Note: Parts extracted from the component side.

Note on SCHEMATIC DIAGRAM (DAS BOARD):

Ref. No.	Location
D10	E-7
D11	F-10
D12	F-8
D13	D-4
D14	F-4
D15	F-4
D16	B-1
D17	B-1
D18	A-1
D19	A-1
D20	A-1
C100	C-4
C101	C-4
C102	C-8
C103	F-4
C104	D-8
C105	D-4
C106	D-3
C107	C-8
C108	C-8
C109	C-8
C110	C-8
C111	F-1
C112	F-1
C113	F-1
C114	F-1
C115	F-1
C116	F-1
C117	F-1
C118	F-1
C119	F-1
C120	F-1
C121	F-1
C122	F-1
C123	F-1
C124	F-1
C125	F-1
C126	F-1
C127	F-1
C128	F-1
C129	F-1
C130	F-1

Note:

- All capacitors are in μF unless otherwise noted. pF: μF 50WV or less are not indicated except for electrolytics and tantalums.
- All resistors are in Ω and 1/4W or less unless otherwise specified.
- ⚡: nonflammable resistor.
- ⚡: audible resistor.
- Voltages are dc with respect to ground under no-signal condition.
- Voltages are taken with a VOM (50 kΩ/V).
- Voltage variations may be noted due to normal production tolerances.
- Signal path.
- ⇨: PHONO
- Switches:

Ref. No.	Switch	Position
S1	POWER	OFF
S100	CARTRIDGE	MM
S101	REC OUT SELECTOR	PHONO
S102	INPUT SELECTOR	PHONO
S301-1	LOUDNESS	OFF
S301-2	SUBSONIC	OFF
S301-3	DIGITAL ANALOG INPUT	ANALOG
S302	CD DIRECT	OFF
S303	CD TONE	OFF
S500	SPEAKERS	OFF
VS1 (E)	VOLTAGE SELECTOR	240V

The bracketed numbers in the diagram are applied to the E model.

Free service manuals
Gratis schema's
Digitized by
www.freeservicemanuals.info

2-6. PRINTED WIRING BOARDS (DAS BOARD)

Note on PRINTED WIRING BOARDS (DAS BOARD)
 • ○ : parts extracted from the component side.

Note on SCHEMATIC DIAGRAM (DAS BOARD)

- All capacitors are in μF unless otherwise noted. pF: μF 50WV or less are not indicated except for electrolytics and tantalums.
- All resistors are in Ω and $1/4\text{W}$ or less unless otherwise specified.
- : nonflammable resistor.
- : fusible resistor.
- Voltages are dc with respect to ground under no-signal conditions.
- Voltages are taken with a VOM (50 k Ω /V). Voltage variations may be noted due to normal production tolerances.
- Waveforms are taken with an oscilloscope. Voltage variations may be noted due to normal production tolerances.
- Circled numbers refer to waveforms.
- Switches:

• Semiconductor Location

Ref. No.	Location
D10	E-7
D11	F-10
D12	F-8
D900	D-4
D901	F-4
D902	F-4
D950	B-1
D951	B-1
D952	A-1
D953	A-1
IC900	C-4
IC901	C-4
IC902	C-5
IC903	F-4
IC904	D-5
IC905	D-4
IC906	D-3
IC907	F-3
IC908	E-2
IC909	C-5
IC950	C-3
IC951	B-3
IC952	C-1
IC953	C-2
Q150	F-1
Q151	F-1
Q250	F-1
Q251	F-1
Q900	G-4
Q901	G-2
Q902	F-2

Ref No	Switch	Position
S10	INPUT SELECTOR	COAXIAL

Note: The components identified by mark or dotted line with mark are critical for safety. Replace only with part number specified.

Position	Switch	Ref. No.
OFF	POWER	S1
MM	CARRIAGE	S100
PHONO	REC OUT SELECTOR	S101
PHONO	INPUT SELECTOR	S102
OFF	LOUDNESS	S201-1
OFF	SUBSONIC	S201-2
ANALOG	DIGITAL ANALOG INPUT	S201-3
OFF	CD DIRECT	S202
OFF	TONE	S203
OFF	SPEAKERS	S204
240V	VOLTAGE SELECTOR	S205

Note: The component identified by mark or dotted line with mark are critical for safety. Replace only with part number specified.

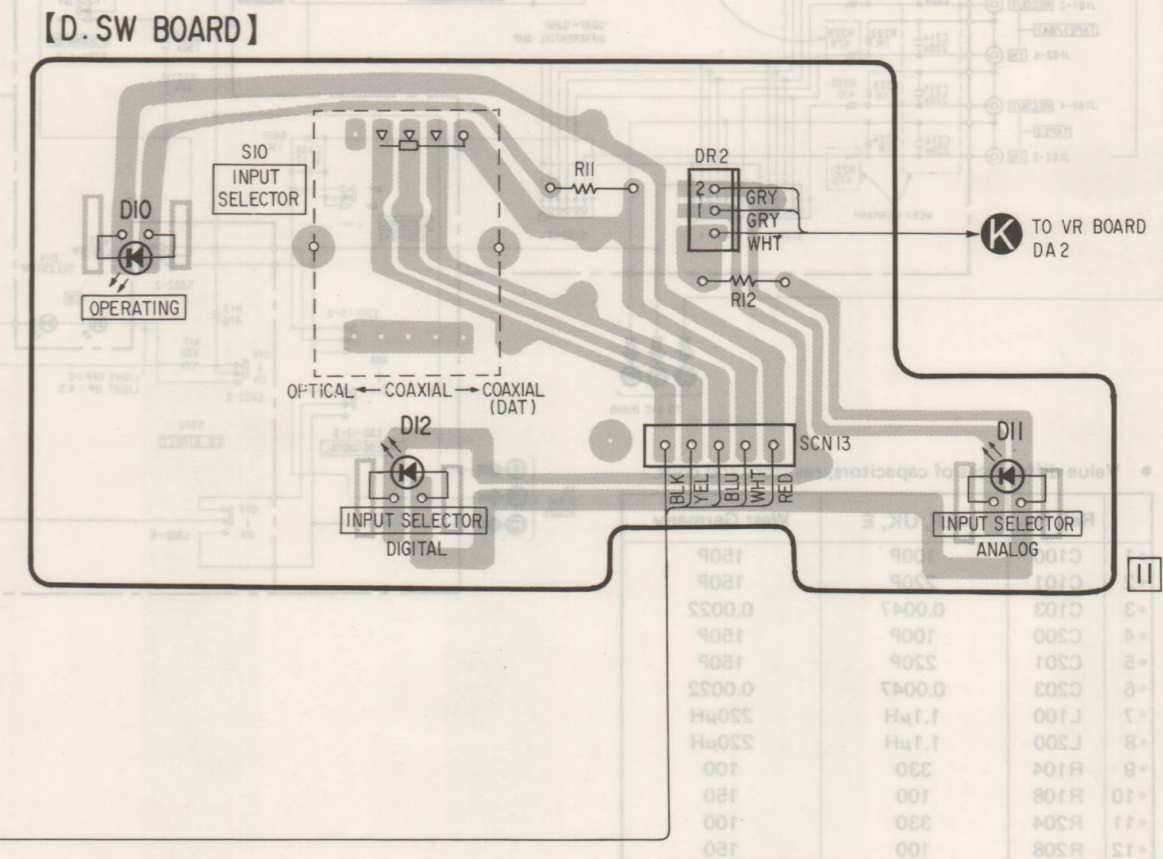
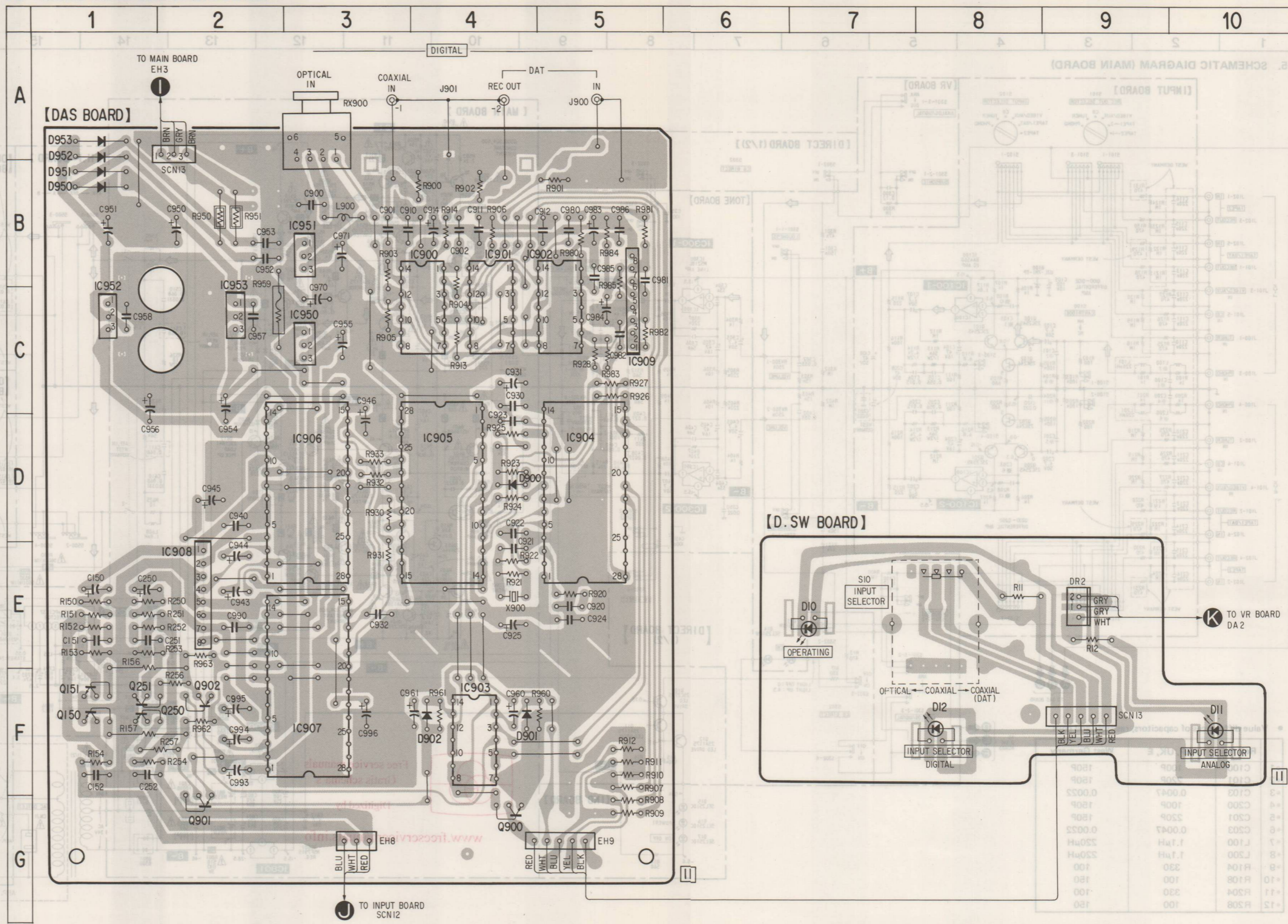

2-7. SCHEMATIC DIAGRAM (DAS BOARD)

See page 16 for note.

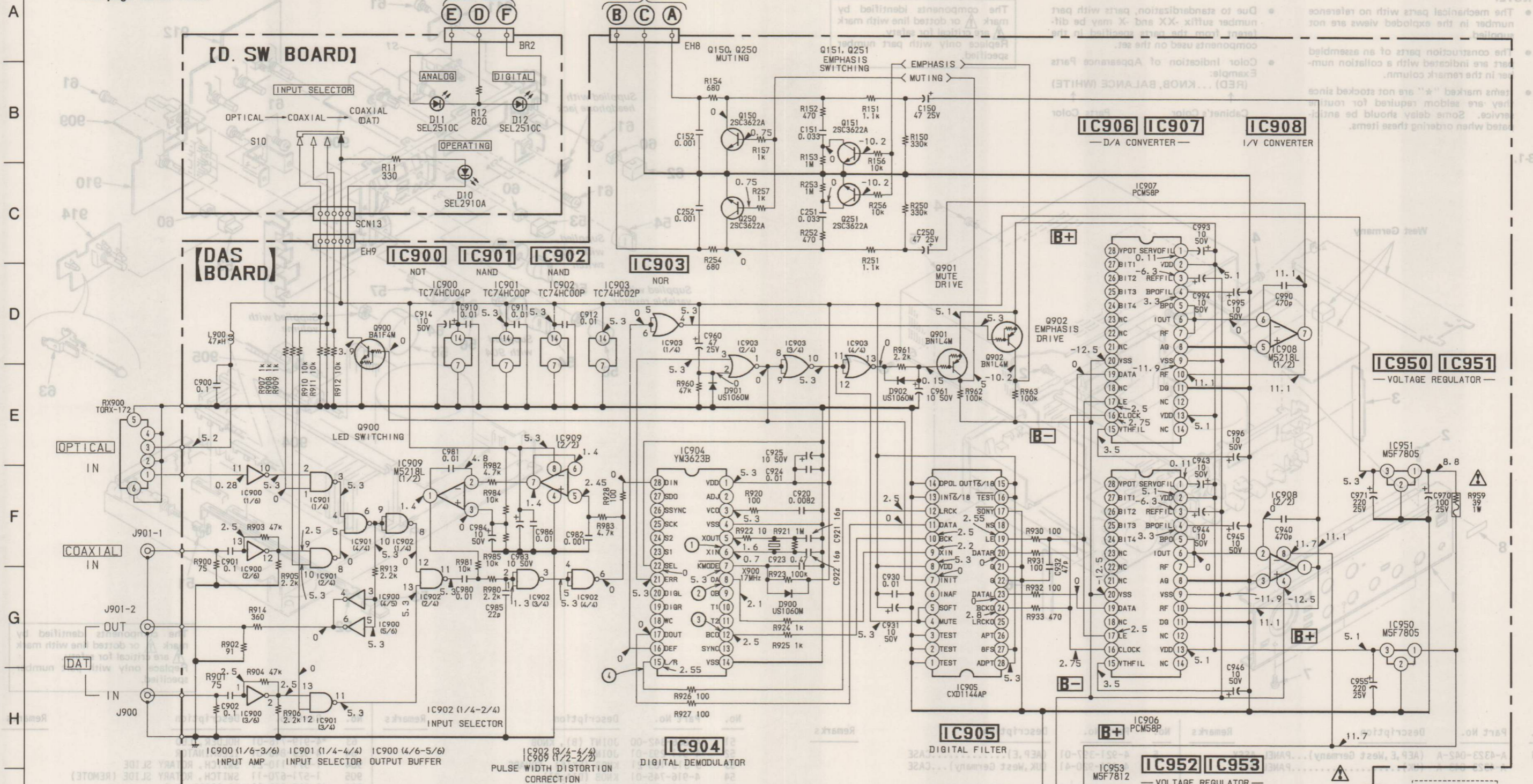

WAVE FORMS

① IC904 P. 6

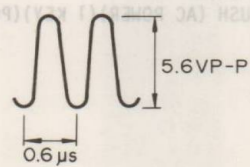

② IC904 P. 8

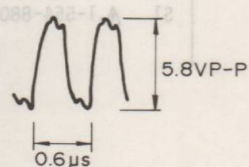

③ IC904 P. 12

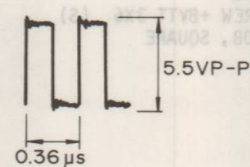

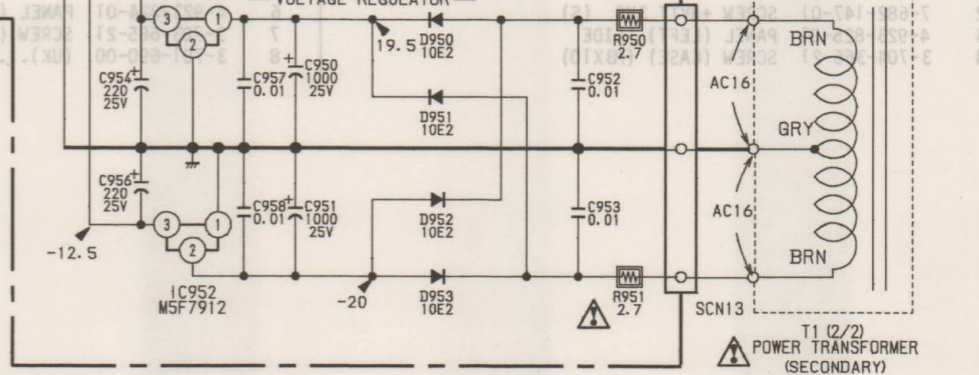
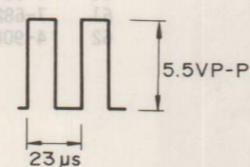

④ IC904 P. 15



SECTION 3 EXPLODED VIEWS

- NOTE:**
- The mechanical parts with no reference number in the exploded views are not supplied.
 - The construction parts of an assembled part are indicated with a collation number in the remark column.
 - Items marked "★" are not stocked since they are seldom required for routine service. Some delay should be anticipated when ordering these items.

- Due to standardization, parts with part number suffix -XX and -X may be different from the parts specified in the components used on the set.
- Color Indication of Appearance Parts
Example:
(RED) ... KNOB, BALANCE (WHITE)
↑ Cabinet's Color ↑ Parts Color

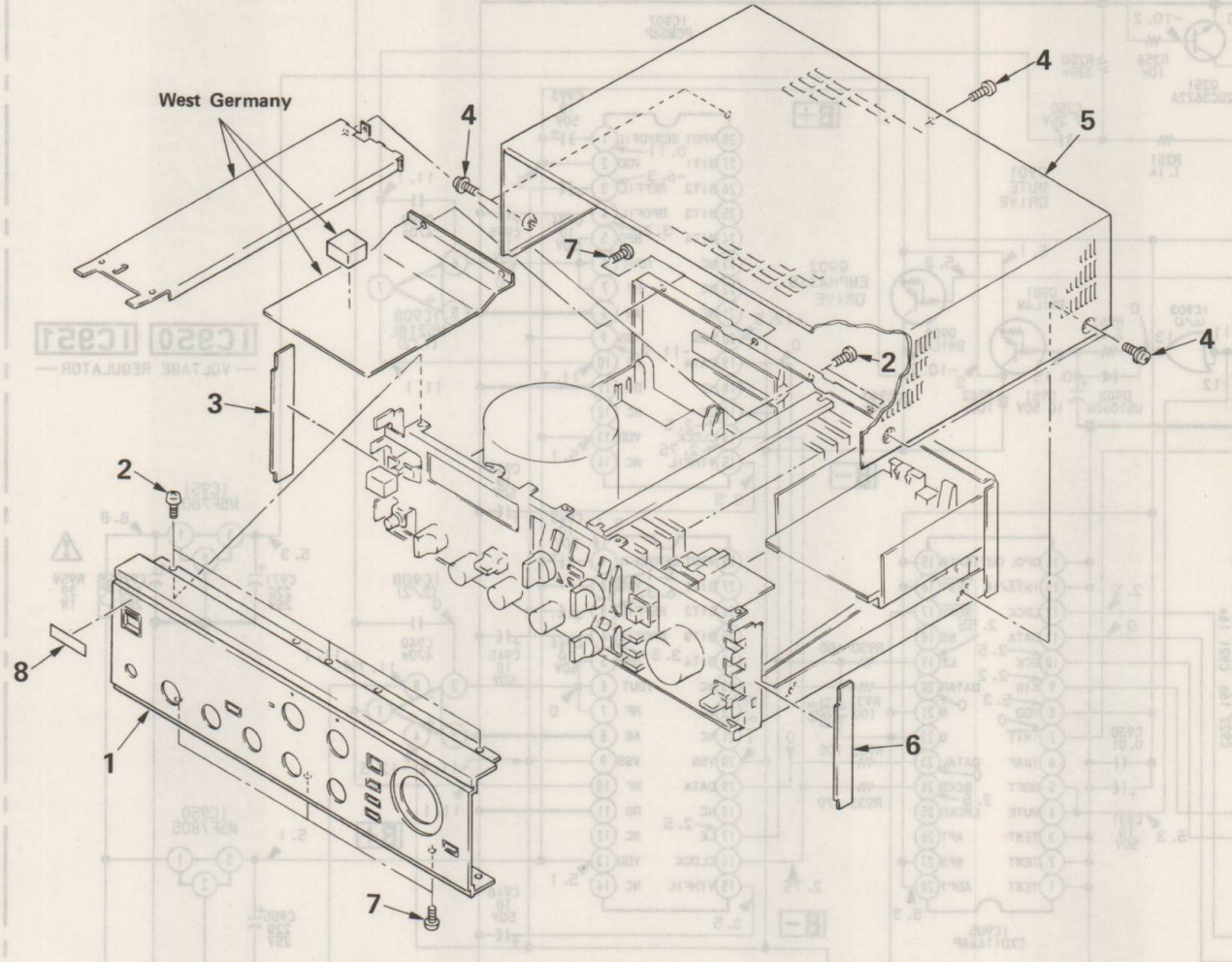

The components identified by mark  or dotted line with mark  are critical for safety. Replace only with part number specified.

3-1.

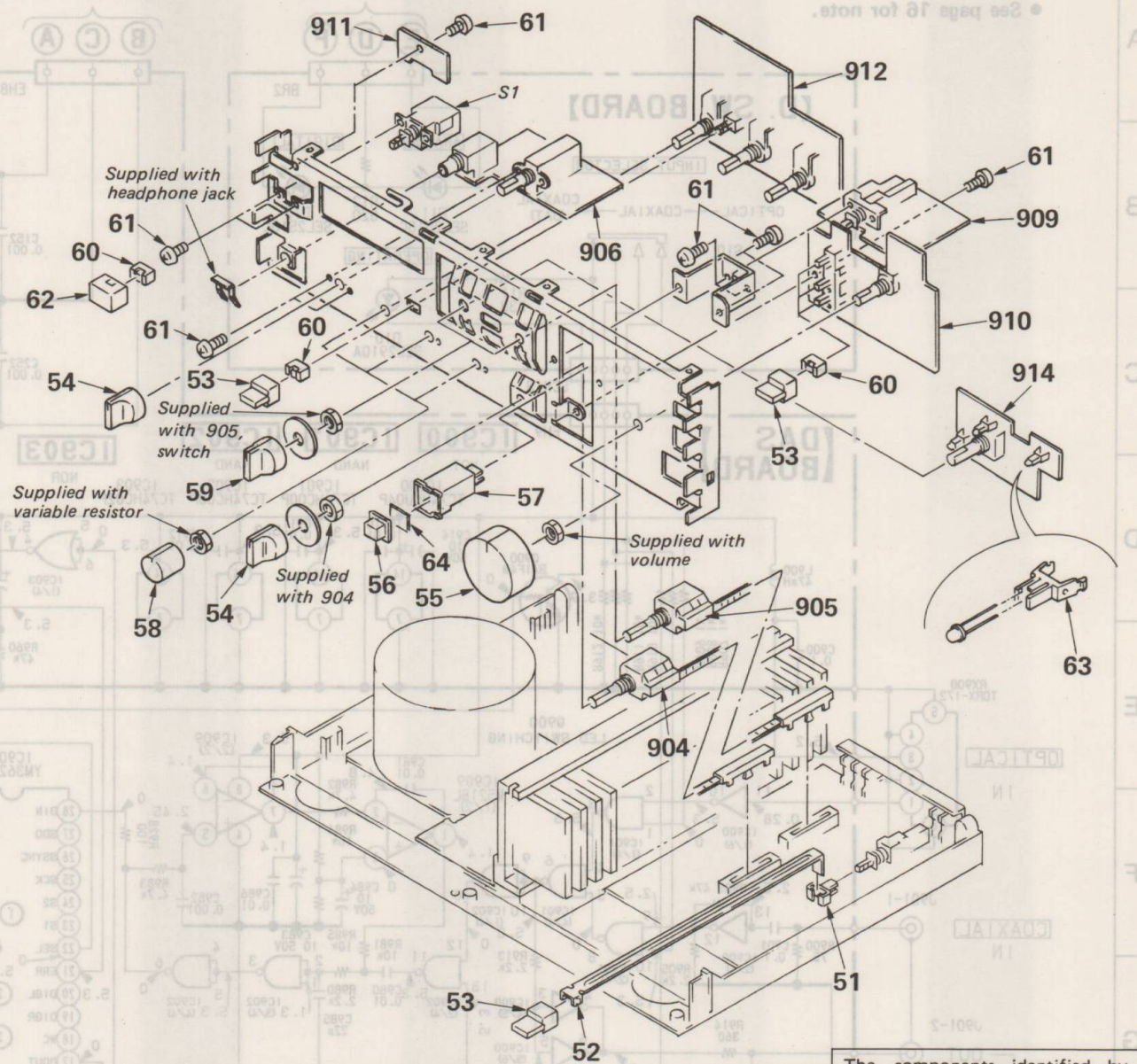

3-2.



The components identified by mark  or dotted line with mark  are critical for safety. Replace only with part number specified.

No.	Part No.	Description	Remarks	No.	Part No.	Description	Remarks
1	A-4323-042-A	(AEP,E,West Germany)...PANEL ASSY		5	4-921-397-01	(AEP,E).....CASE	
	A-4323-043-A	(UK).....PANEL ASSY			4-924-920-41	(UK,West Germany)...CASE	
2	7-682-147-01	SCREW +BVTT 3X6 (S)		6	4-923-824-01	PANEL (RIGHT), SIDE	
3	4-923-825-01	PANEL (LEFT), SIDE		7	3-703-685-21	SCREW (+BV 3X8)	
4	3-704-366-21	SCREW (CASE) (MBX10)		8	3-701-690-00	(UK)...LABEL (MADE IN JAPAN)	

No.	Part No.	Description	Remarks	No.	Part No.	Description	Remarks
51	4-866-342-00	JOINT (B), KNOB		63	*4-919-716-01	HOLDER, LED	
52	*4-911-293-01	JOINT		64	4-923-846-01	ILLUMINATOR	
53	3-315-105-21	KNOB (5X16), SQUARE		904	1-571-110-21	SWITCH, ROTARY SLIDE	
54	4-916-745-01	KNOB (DIA.21)		905	1-571-670-11	SWITCH, ROTARY SLIDE (REMOTE)	
55	X-4919-703-1	KNOB (VOL) ASSY		906	*1-628-002-11	PC BOARD, H.P	
56	4-923-826-11	BUTTON		909	*1-628-005-11	PC BOARD, DIRECT	
57	*4-923-829-01	HOUSE		910	*1-628-006-11	PC BOARD, VR	
58	4-916-746-01	KNOB (DIA.21)		911	*1-628-007-11	PC BOARD, IND	
59	4-921-997-01	KNOB		912	*1-628-008-11	PC BOARD, TONE	
60	*4-864-307-00	RING		914	*1-628-010-11	PC BOARD, D.SW	
61	7-682-147-01	SCREW +BVTT 3X6 (S)		S1	 1-554-880-11	SWITCH, PUSH (AC POWER)(1 KEY)(POWER)	
62	4-908-856-01	KNOB, SQUARE					

3-3.

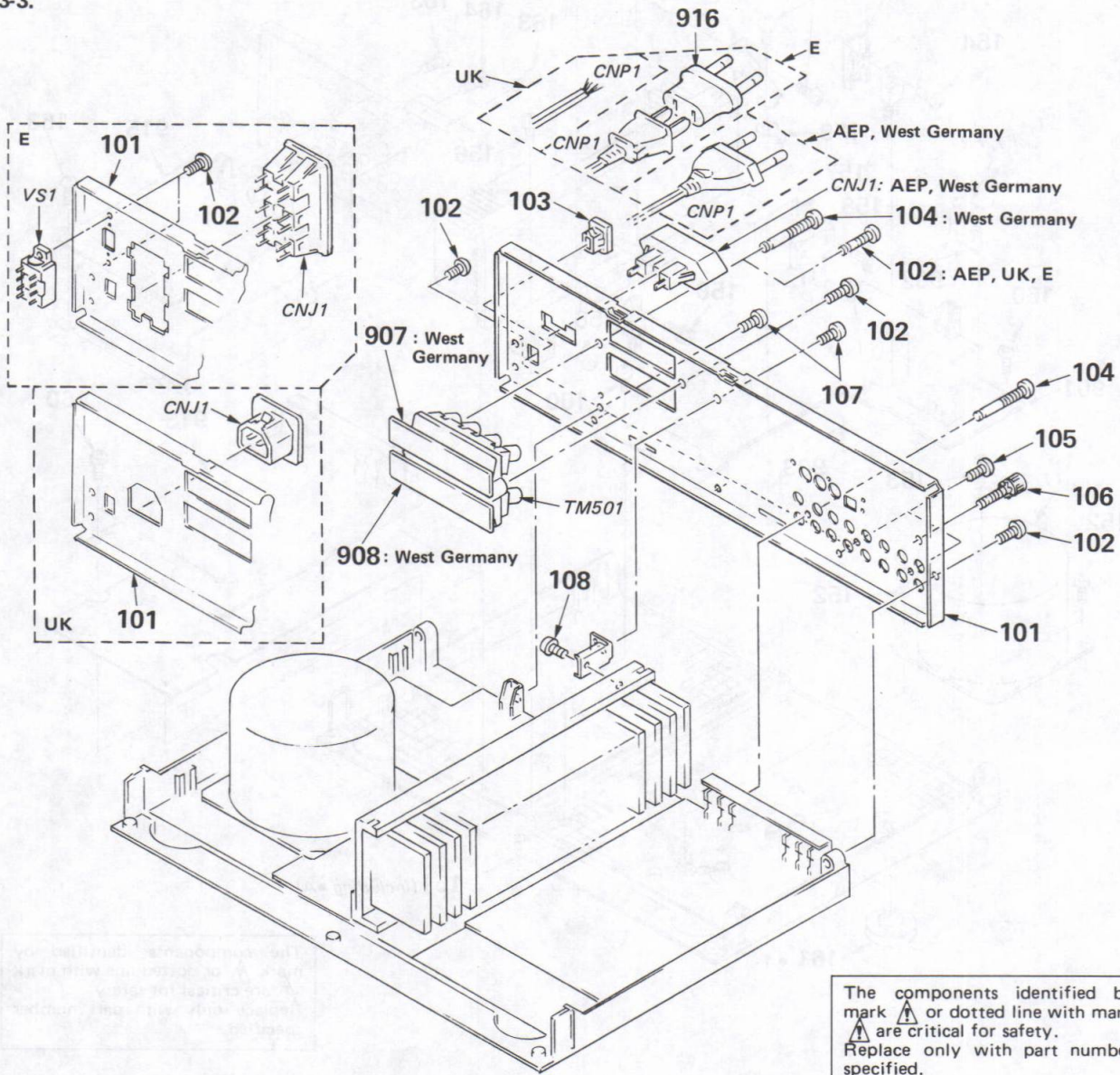

The components identified by mark or dotted line with mark are critical for safety. Replace only with part number specified.

No.	Part No.	Description	Remarks
101	*4-923-818-01	(E).....PANEL, BACK	
	*4-923-818-11	(UK).....PANEL, BACK	
	*4-923-818-31	(West Germany)...PANEL, BACK	
	*4-923-818-41	(AEP).....PANEL, BACK	
102	7-685-647-79	SCREW +BVTP 3X10 TYPE2 N-S	
103	*3-703-244-00	(AEP,UK,West Germany)BUSHING (2104), CORD	
	*3-703-571-00	(E).....BUSHING (S)(4516), CORD	
104	3-704-242-01	(AEP,West Germany) ...SCREW, TERMINAL, + BVTP CLAW	
105	7-621-849-00	SCREW, TAPPING	
106	*3-706-165-00	SCREW	
107	3-703-685-21	SCREW (+BV 3X8)	
108	7-682-548-01	SCREW +B 3X8	

No.	Part No.	Description	Remarks
907	*1-628-003-11	(West Germany)...PC BOARD, OUT (A)	
908	*1-628-004-11	(West Germany)...PC BOARD, OUT (B)	
916	.1-526-565-00	(E)...AC PLUG ADAPTOR	
CNJ1	.1-526-696-11	(E).....OUTLET, AC (3 GANG)(AC OUTLET)	
CNJ1	.1-526-751-00	(UK).....OUTLET, AC (AC OUTLET)	
CNJ1	.1-526-794-11	(AEP,West Germany) ...OUTLET, AC (AC OUTLET)	
CNP1	.1-551-188-XX	(E).....CORD, POWER	
CNP1	.1-555-750-00	(AEP,West Germany)...CORD, POWER	
CNP1	.1-556-035-00	(UK).....CORD, POWER	
TM501	1-536-662-00	TERMINAL BOARD (SPEAKER)	
VS1	.1-570-307-11	(E)...SWITCH, VOLTAGE CHANGE	

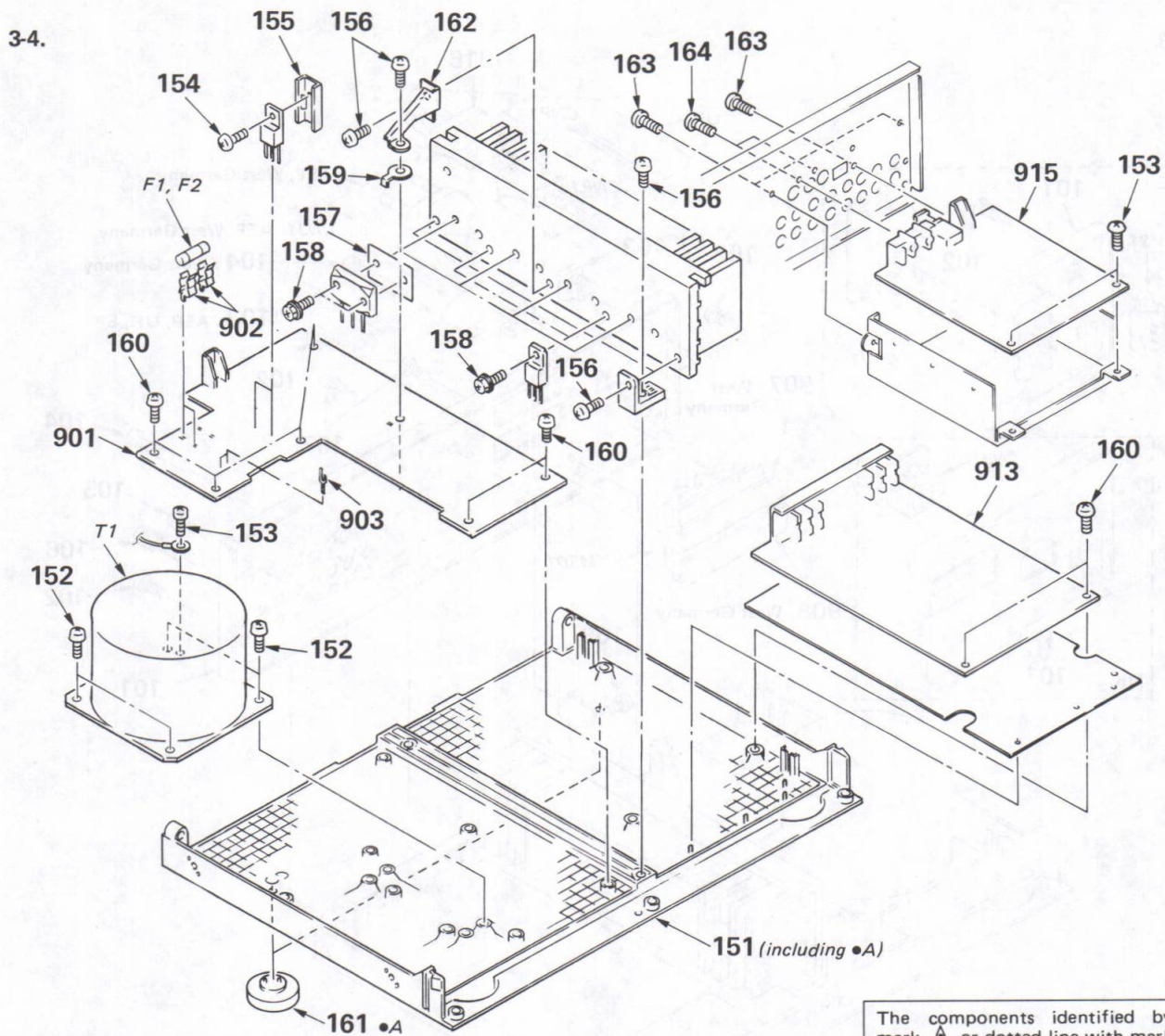

The components identified by mark or dotted line with mark are critical for safety. Replace only with part number specified.

No.	Part No.	Description	Remarks
151	*X-4885-937-1 *X-4885-938-1	(E).....CHASSIS ASSY (AEP,UK,West Germany)...CHASSIS ASSY	
152	7-685-661-79	SCREW +BVTP 4X12 TYPE2 N-S	
153	7-682-147-01	SCREW +BVTT 3X6 (S)	
154	7-682-548-04	SCREW +BVTT 3X8 (S)	
155	*3-309-144-21	HEAT SINK	
156	7-682-548-01	SCREW +B 3X8	
157	4-885-901-31	SHEET, RADIATION	
158	7-682-550-09	SCREW +B 3X12	
159	4-924-264-01	TERMINAL, MOUNT	
160	7-685-647-79	SCREW +BVTP 3X10 TYPE2 N-S	
161	X-4885-935-1 X-4885-936-1	(AEP,UK,West Germany)...FOOT ASSY (E).....FOOT ASSY	
162	*4-923-847-01	BRACKET (P.B.)	
163	3-703-685-21	SCREW (+BV 3x8)	
164	7-621-849-00	SCREW, TAPPING	

No.	Part No.	Description	Remarks
901	*A-4388-794-A *A-4388-796-A	(AEP,UK,West Germany)..MOUNTED PCB, MAIN (E).....MOUNTED PCB, MAIN	
902	1-533-183-11	HOLDER, FUSE	
903	1-535-416-00	(AEP,West Germany)...TERMINAL	
913	*1-628-009-11	PC BOARD, INPUT	
915	*A-4474-635-A	MOUNTED PCB, DAS	
F1	1-532-350-00	FUSE, TIME-LAG (4A)	
F2	1-532-286-00	(AEP,UK,West Germany) ...FUSE, TIME-LAG (2.5A)	
F2	1-532-350-00	(E).....FUSE, TIME-LAG (4A)	
T1	1-449-432-11	(AEP,UK,West Germany) ...TRANSFORMER, POWER	
T1	1-449-433-11	(E).....TRANSFORMER, POWER	

SECTION 4

ELECTRICAL PARTS LIST

NOTE:

- Due to standardization, replacements in the parts list may be different from the parts specified in the diagrams or the components used on the set.
- Items marked "★" are not stocked since they are seldom required for routine service. Some delay should be anticipated when ordering these items.
- If there are two or more same circuits in a set such as a stereophonic machine, only typical circuit parts may be indicated and capacitors and resistors in other same circuits may be omitted.

CAPACITORS:
MF: μ F, PF: μ MF.

RESISTORS

- All resistors are in ohms.
- F: nonflammable

COILS

- MMH: mH, UH: μ H

SEMICONDUCTORS

In each case, U: μ , for example:

UA...: μ A..., UPA...: μ PA...,
UPC...: μ PC, UPD...: μ PD...

The components identified by mark Δ or dotted line with mark Δ are critical for safety. Replace only with part number specified.

Ref.No.	Part No.	Description	Ref.No.	Part No.	Description
901	*A-4388-794-A	(AEP,UK,West Germany) ...MOUNTED PCB, MAIN	C200	1-162-282-31	(AEP,UK,E).....CERAMIC 100PF 10% 50V
	*A-4388-796-A	(E).....MOUNTED PCB, MAIN	C200	1-162-284-31	(West Germany)...CERAMIC 150PF 10% 50V
902	1-533-183-11	HOLDER, FUSE	C201	1-162-284-31	(West Germany)...CERAMIC 150PF 10% 50V
903	1-535-416-00	(AEP,West Germany)...TERMINAL	C201	1-162-286-31	(AEP,UK,E).....CERAMIC 220PF 10% 50V
904	1-571-110-21	SWITCH, ROTARY SLIDE	C202	1-124-927-11	ELECT 4.7MF 20% 50V
905	1-571-670-11	SWITCH, ROTARY SLIDE (REMOTE)	C203	1-130-475-00	(West Germany)...FILM 0.0022MF 5% 50V
906	*1-628-002-11	PC BOARD H.P	C203	1-130-479-00	(AEP,UK,E).....FILM 0.0047MF 5% 50V
907	*1-628-003-11	(West Germany)...PC BOARD, OUT (A)	C204	1-124-477-11	ELECT 47MF 20% 16V
908	*1-628-004-11	(West Germany)...PC BOARD, OUT (B)	C205	1-136-162-00	FILM 0.056MF 5% 50V
909	*1-628-005-11	PC BOARD, DIRECT	C206	1-136-155-00	FILM 0.015MF 5% 50V
910	*1-628-006-11	PC BOARD, VR	C207	1-124-925-11	ELECT 2.2MF 20% 50V
911	*1-628-007-11	PC BOARD, IND	C208	1-124-910-11	ELECT 47MF 20% 50V
912	*1-628-008-11	PC BOARD, TONE	C210	1-162-286-31	(West Germany)...CERAMIC 220PF 10% 50V
913	*1-628-009-11	PC BOARD, INPUT	C211	1-162-286-31	(West Germany)...CERAMIC 220PF 10% 50V
914	*1-628-010-11	PC BOARD, D.SW	C212	1-162-286-31	(West Germany)...CERAMIC 220PF 10% 50V
915	*A-4474-635-A	MOUNTED PCB, DAS	C213	1-162-286-31	(West Germany)...CERAMIC 220PF 10% 50V
916	Δ 1-526-565-00	(E)...AC PLUG ADAPTOR	C214	1-162-286-31	(West Germany)...CERAMIC 220PF 10% 50V
C1	Δ 1-161-744-00	CERAMIC 0.01MF 400V	C215	1-162-286-31	(West Germany)...CERAMIC 220PF 10% 50V
C2	Δ 1-161-744-00	(E)...CERAMIC 0.01MF 400V	C216	1-162-286-31	(West Germany)...CERAMIC 220PF 10% 50V
C100	1-162-282-31	(AEP,UK,E).....CERAMIC 100PF 10% 50V	C220	1-161-494-00	(West Germany)...CERAMIC 0.022MF 25V
C100	1-162-284-31	(West Germany)...CERAMIC 150PF 10% 50V	C250	1-124-477-11	ELECT 47MF 20% 25V
C101	1-162-284-31	(West Germany)...CERAMIC 150PF 10% 50V	C251	1-136-159-00	FILM 0.033MF 5% 50V
C101	1-162-286-31	(AEP,UK,E).....CERAMIC 220PF 10% 50V	C252	1-130-471-00	MYLAR 0.001MF 5% 50V
C102	1-124-927-11	ELECT 4.7MF 20% 50V	C300	1-136-166-00	FILM 0.12MF 5% 50V
C103	1-130-475-00	(West Germany)...FILM 0.0022MF 5% 50V	C301	1-162-284-31	CERAMIC 150PF 10% 50V
C103	1-130-479-00	(AEP,UK,E).....FILM 0.0047MF 5% 50V	C302	1-136-159-00	FILM 0.033MF 5% 50V
C104	1-124-477-11	ELECT 47MF 20% 16V	C303	1-126-163-11	ELECT 4.7MF 20% 50V
C105	1-136-162-00	FILM 0.056MF 5% 50V	C304	1-162-211-31	CERAMIC 33PF 5% 50V
C106	1-136-155-00	FILM 0.015MF 5% 50V	C305	1-124-589-11	ELECT 47MF 20% 16V
C107	1-124-925-11	ELECT 2.2MF 20% 50V	C306	1-162-217-31	CERAMIC 56PF 5% 50V
C108	1-124-910-11	ELECT 47MF 20% 50V	C307	1-126-163-11	ELECT 4.7MF 20% 50V
C109	1-124-443-00	ELECT 100MF 20% 10V	C308	1-130-476-00	MYLAR 0.0027MF 5% 50V
C110	1-162-286-31	(West Germany)...CERAMIC 220PF 10% 50V	C309	1-136-158-00	FILM 0.027MF 5% 50V
C111	1-162-286-31	(West Germany)...CERAMIC 220PF 10% 50V	C310	1-130-481-00	MYLAR 0.0068MF 5% 50V
C112	1-162-286-31	(West Germany)...CERAMIC 220PF 10% 50V	C311	1-136-163-00	FILM 0.068MF 5% 50V
C113	1-162-286-31	(West Germany)...CERAMIC 220PF 10% 50V	C350	1-161-494-00	CERAMIC 0.022MF 25V
C114	1-162-286-31	(West Germany)...CERAMIC 220PF 10% 50V	C351	1-162-282-31	CERAMIC 100PF 10% 50V
C115	1-162-286-31	(West Germany)...CERAMIC 220PF 10% 50V	C352	1-162-282-31	(West Germany)...CERAMIC 100PF 10% 50V
C116	1-162-286-31	(West Germany)...CERAMIC 220PF 10% 50V	C400	1-136-166-00	FILM 0.12MF 5% 50V
C120	1-161-494-00	CERAMIC 0.022MF 25V	C401	1-162-284-31	CERAMIC 150PF 10% 50V
C150	1-124-477-11	ELECT 47MF 20% 25V	C402	1-136-159-00	FILM 0.033MF 5% 50V
C151	1-136-159-00	FILM 0.033MF 5% 50V	C403	1-126-163-11	ELECT 4.7MF 20% 50V
C152	1-130-471-00	MYLAR 0.001MF 5% 50V	C404	1-162-211-31	CERAMIC 33PF 5% 50V

Ref.No.	Part No.	Description			
C405	1-124-589-11	ELECT	47MF	20%	16V
C406	1-162-217-31	CERAMIC	56PF	5%	50V
C407	1-126-163-11	ELECT	4.7MF	20%	50V
C408	1-130-476-00	MYLAR	0.0027MF	5%	50V
C409	1-136-158-00	FILM	0.027MF	5%	50V
C410	1-130-481-00	MYLAR	0.0068MF	5%	50V
C411	1-136-163-00	FILM	0.068MF	5%	50V
C451	1-162-282-31	CERAMIC	100PF	10%	50V
C452	1-162-282-31	(West Germany)...CERAMIC	100PF	10%	50V
C500	1-124-927-11	ELECT	4.7MF	20%	50V
C501	1-130-475-00	FILM	0.0022MF	5%	50V
C502	1-124-477-11	ELECT	47MF	20%	16V
C503	1-161-959-00	(AEP,UK,West Germany) ...CERAMIC	22PF	10%	500V
C504	1-124-477-11	ELECT	47MF	20%	16V
C505	1-162-197-31	CERAMIC	6.8PF	10%	50V
C506	1-161-959-00	CERAMIC	22PF	10%	500V
C507	1-124-589-11	ELECT	47MF	20%	16V
C510	1-136-159-00	(E)....FILM	0.033MF	5%	50V
C510	1-136-163-00	(AEP,UK,West Germany) ...FILM	0.068MF	5%	50V
C511	1-136-163-00	(AEP,UK,West Germany) ...FILM	0.068MF	5%	50V
C512	1-161-379-00	(West Germany)..CERAMIC	0.01MF	30%	25V
C513	1-161-494-00	(West Germany)..CERAMIC	0.022MF	30%	25V
C514	1-161-379-00	(West Germany)..CERAMIC	0.01MF	30%	25V
C515	1-161-494-00	(West Germany)..CERAMIC	0.022MF	30%	25V
C550	1-161-494-00	(West Germany)..CERAMIC	0.022MF		25V
C600	1-124-927-11	ELECT	4.7MF	20%	50V
C601	1-130-475-00	FILM	0.0022MF	5%	50V
C602	1-124-477-11	ELECT	47MF	20%	16V
C603	1-161-959-00	(AEP,UK,West Germany) ...CERAMIC	22PF	10%	500V
C604	1-124-477-11	ELECT	47MF	20%	16V
C605	1-162-197-31	CERAMIC	6.8PF	10%	50V
C606	1-161-959-00	CERAMIC	22PF	10%	500V
C607	1-124-589-11	ELECT	47MF	20%	16V
C610	1-136-159-00	(E)....FILM	0.033MF	5%	50V
C610	1-136-163-00	(AEP,UK,West Germany) ...FILM	0.068MF	5%	50V
C611	1-136-163-00	(AEP,UK,West Germany) ...FILM	0.068MF	5%	50V
C612	1-161-379-00	(West Germany)..CERAMIC	0.01MF	30%	25V
C613	1-161-494-00	(West Germany)..CERAMIC	0.022MF	30%	25V
C614	1-161-379-00	(West Germany)..CERAMIC	0.01MF	30%	25V
C615	1-161-494-00	(West Germany)..CERAMIC	0.022MF	30%	25V
C650	1-161-494-00	(West Germany)..CERAMIC	0.022MF		25V
C700	1-161-494-00	CERAMIC	0.022MF		25V
C701	1-126-233-11	ELECT	22MF	20%	25V
C702	1-126-176-11	ELECT	220MF	20%	6.3V
C703	1-124-477-11	ELECT	47MF	20%	16V
C704	1-124-443-00	ELECT	100MF	20%	10V
C800	1-102-355-00	CERAMIC	0.01MF		250V
C801	1-125-522-11	(E)...ELECT	12000MF	20%	71V
C801	1-125-536-11	(AEP,UK,West Germany) ...ELECT	10000MF	20%	50V
C802	1-125-522-11	(E)...ELECT	12000MF	20%	71V
C802	1-125-536-11	(AEP,UK,West Germany) ...ELECT	10000MF	20%	50V

Ref.No.	Part No.	Description			
C803	1-126-104-11	ELECT	470MF	20%	35V
C804	1-126-104-11	ELECT	470MF	20%	35V
C805	1-124-478-11	ELECT	100MF	20%	25V
C806	1-124-478-11	ELECT	100MF	20%	25V
C807	1-102-355-00	CERAMIC	0.01MF		250V
C808	1-124-637-11	(AEP,UK,West Germany) ...ELECT	1000MF	20%	50V
C808	1-126-368-11	(E)...ELECT	1000MF	20%	80V
C809	1-124-637-11	(AEP,UK,West Germany) ...ELECT	1000MF	20%	50V
C809	1-126-368-11	(E)...ELECT	1000MF	20%	80V
C812	1-124-927-11	ELECT	4.7MF	20%	50V
C900	1-136-165-00	FILM	0.1MF	5%	50V
C901	1-136-165-00	FILM	0.1MF	5%	50V
C902	1-136-165-00	FILM	0.1MF	5%	50V
C910	1-101-004-00	CERAMIC	0.01MF		50V
C911	1-101-004-00	CERAMIC	0.01MF		50V
C912	1-101-004-00	CERAMIC	0.01MF		50V
C914	1-123-875-11	ELECT	10MF	20%	50V
C920	1-130-482-00	MYLAR	0.0082MF	5%	50V
C921	1-102-512-00	CERAMIC	16PF	5%	50V
C922	1-102-512-00	CERAMIC	16PF	5%	50V
C923	1-136-173-00	FILM	0.47MF	5%	50V
C924	1-101-004-00	CERAMIC	0.01MF		50V
C925	1-123-875-11	ELECT	10MF	20%	50V
C930	1-101-004-00	CERAMIC	0.01MF		50V
C931	1-123-875-11	ELECT	10MF	20%	50V
C932	1-101-880-00	CERAMIC	47PF	5%	50V
C940	1-130-467-00	MYLAR	470PF	5%	50V
C943	1-123-875-11	ELECT	10MF	20%	50V
C944	1-123-875-11	ELECT	10MF	20%	50V
C945	1-123-875-11	ELECT	10MF	20%	50V
C946	1-123-875-11	ELECT	10MF	20%	50V
C950	1-124-557-11	ELECT	1000MF	20%	25V
C951	1-124-557-11	ELECT	1000MF	20%	25V
C952	1-101-004-00	CERAMIC	0.01MF		50V
C953	1-101-004-00	CERAMIC	0.01MF		50V
C954	1-124-120-11	ELECT	220MF	20%	25V
C955	1-124-120-11	ELECT	220MF	20%	25V
C956	1-124-120-11	ELECT	220MF	20%	25V
C957	1-101-004-00	CERAMIC	0.01MF		50V
C958	1-101-004-00	CERAMIC	0.01MF		50V
C960	1-124-477-11	ELECT	47MF	20%	25V
C961	1-123-875-11	ELECT	10MF	20%	50V
C970	1-124-478-11	ELECT	100MF	20%	25V
C971	1-124-120-11	ELECT	220MF	20%	25V
C980	1-101-004-00	CERAMIC	0.01MF		50V
C981	1-136-153-00	FILM	0.01MF	5%	50V
C982	1-101-001-00	CERAMIC	0.001MF		50V
C983	1-123-875-11	ELECT	10MF	20%	50V
C984	1-123-875-11	ELECT	10MF	20%	50V
C985	1-102-959-00	CERAMIC	22PF	5%	50V
C986	1-101-004-00	CERAMIC	0.01MF		50V
C990	1-130-467-00	MYLAR	470PF	5%	50V
C993	1-123-875-11	ELECT	10MF	20%	50V
C994	1-123-875-11	ELECT	10MF	20%	50V
C995	1-123-875-11	ELECT	10MF	20%	50V
C996	1-123-875-11	ELECT	10MF	20%	50V

Ref.No.	Part No.	Description
CNJ1	△.1-526-696-11	(E).....OUTLET, AC (3 GANG)(AC OUTLET)
CNJ1	△.1-526-751-00	(UK).....OUTLET, AC (AC OUTLET)
CNJ1	△.1-526-794-11	(AEP,West Germany) ...OUTLET, AC (AC OUTLET)
CNP1	△.1-551-188-XX	(E).....CORD, POWER
CNP1	△.1-555-750-00	(AEP,West Germany)...CORD, POWER
CNP1	△.1-556-035-00	(UK).....CORD, POWER
D10	8-719-301-60	DIODE SEL2910A-C
D11	8-719-303-00	DIODE SEL2510C
D12	8-719-303-00	DIODE SEL2510C
D13	8-719-304-14	DIODE SEL2510W
D14	8-719-304-14	DIODE SEL2510W
D15	8-719-303-00	DIODE SEL2510C
D16	8-719-303-00	DIODE SEL2510C
D17	8-719-303-00	DIODE SEL2510C
D100	8-719-000-90	DIODE UZL-7M3
D500	8-719-000-51	DIODE UZL-6L2
D501	8-719-000-26	DIODE US1060M
D504	8-719-002-83	DIODE US1090M
D505	8-719-002-83	DIODE US1090M
D600	8-719-000-51	DIODE UZL-6L2
D601	8-719-000-26	DIODE US1060M
D604	8-719-002-83	DIODE US1090M
D605	8-719-002-83	DIODE US1090M
D700	8-719-000-26	DIODE US1060M
D701	8-719-000-26	(AEP,UK,West Germany)...DIODE US1060M
D800	8-719-200-80	DIODE D300
D801	8-719-200-80	DIODE D300
D802	8-719-200-02	DIODE 10E2
D803	8-719-200-02	DIODE 10E2
D804	8-719-200-02	DIODE 10E2
D805	8-719-200-02	DIODE 10E2
D806	8-719-200-02	DIODE 10E2
D811	8-719-160-87	(E)...DIODE RD33F-B2
D812	8-719-160-87	(E)...DIODE RD33F-B2
D900	8-719-000-26	DIODE US1060M
D901	8-719-000-26	DIODE US1060M
D902	8-719-000-26	DIODE US1060M
D950	8-719-200-02	DIODE 10E2
D951	8-719-200-02	DIODE 10E2
D952	8-719-200-02	DIODE 10E2
D953	8-719-200-02	DIODE 10E2
DR1	*1-564-336-00	PIN, CONNECTOR 2P
DR2	*1-564-337-00	PIN, CONNECTOR 3P
EH1	*1-564-506-11	PLUG, CONNECTOR 3P
EH2	*1-564-507-11	PLUG, CONNECTOR 4P
EH3	*1-564-506-11	PLUG, CONNECTOR 3P
EH4	*1-564-506-11	PLUG, CONNECTOR 3P
EH5	*1-564-508-11	PLUG, CONNECTOR 5P
EH6	*1-564-508-11	PLUG, CONNECTOR 5P
EH7	*1-564-506-11	PLUG, CONNECTOR 3P
EH8	*1-564-518-11	PLUG, CONNECTOR 3P
EH9	*1-564-520-11	PLUG, CONNECTOR 5P
F1	△.1-532-350-00	FUSE, TIME-LAG (4A)

Ref.No.	Part No.	Description
F2	△.1-532-286-00	(AEP,UK,West Germany) ...FUSE, TIME-LAG (2.5A)
F2	△.1-532-350-00	(E).....FUSE, TIME-LAG (4A)
IC100	8-759-923-90	IC BA4560
IC300	8-759-600-02	IC M5218L
IC700	8-759-111-68	IC UPC1237HA
IC800	8-759-604-34	IC M5F7815
IC801	8-759-604-52	IC M5F7915
IC900	8-759-202-13	IC TC74HCU04P
IC901	8-759-202-11	IC TC74HC00P
IC902	8-759-202-11	IC TC74HC00P
IC903	8-759-202-12	IC TC74HC02P
IC904	8-759-973-98	IC YMB623B
IC905	8-752-327-29	IC CXD1144AP
IC906	8-759-979-09	IC PCM58P
IC907	8-759-979-09	IC PCM58P
IC908	8-759-600-02	IC M5218L
IC909	8-759-600-02	IC M5218L
IC950	8-759-604-29	IC M5F7805
IC951	8-759-604-29	IC M5F7805
IC952	8-759-604-51	IC M5F7912
IC953	8-759-604-33	IC M5F7812
J100	1-565-258-21	JACK, PIN 4P (TUNER,PHONO)
J101	1-565-320-11	JACK, PIN 6P (CD,VIDEO/AUX,TAPE 1/DAT)
J102	1-565-320-11	JACK, PIN 6P (TAPE 1/DAT,TAPE 2)
J500	1-563-347-11	JACK, LARGE TYPE (HEADPHONES)
J900	1-565-406-51	JACK, PIN 1P (DAT IN)
J901	1-566-921-21	JACK, PIN 2P (DAT OUT,COAXIAL)
L100	1-410-397-21	(AEP,UK,E)..FERRITE BEAD INDUCTOR 1.1UH
L100	1-413-101-00	(West Germany)...COIL, INPUT 220UH
L101	1-413-101-00	(West Germany)...COIL, INPUT 220UH
L200	1-410-397-21	(AEP,UK,E)..FERRITE BEAD INDUCTOR 1.1UH
L200	1-413-101-00	(West Germany)...COIL, INPUT 220UH
L201	1-413-101-00	(West Germany)...COIL, INPUT 220UH
L500	*1-420-872-00	COIL, AIR CORE 1.8UH
L600	*1-420-872-00	COIL, AIR CORE 1.8UH
L900	1-410-332-11	INDUCTOR 47UH
NH1	*1-560-060-00	PIN, CONNECTOR 2P
NH2	*1-560-060-00	PIN, CONNECTOR 2P
Q10	8-729-178-54	TRANSISTOR 2SC2785
Q11	8-729-117-54	TRANSISTOR 2SA1175
Q12	8-729-117-54	TRANSISTOR 2SA1175
Q100	8-729-354-52	TRANSISTOR 2SC2545
Q101	8-729-354-52	TRANSISTOR 2SC2545
Q102	8-729-201-56	TRANSISTOR 2SK246GR2
Q150	8-729-107-98	TRANSISTOR 2SC3622A-L
Q151	8-729-107-98	TRANSISTOR 2SC3622A-L
Q200	8-729-354-52	TRANSISTOR 2SC2545
Q201	8-729-354-52	TRANSISTOR 2SC2545
Q202	8-729-201-56	TRANSISTOR 2SK246GR2
Q250	8-729-107-98	TRANSISTOR 2SC3622A-L
Q251	8-729-107-98	TRANSISTOR 2SC3622A-L
Q500	△.8-729-108-14	TRANSISTOR 2SA988-F
Q501	△.8-729-697-92	TRANSISTOR 2SA979
Q502	△.8-729-178-54	TRANSISTOR 2SC2785
Q503	8-729-201-56	TRANSISTOR 2SK246GR2
Q504	△.8-729-178-54	TRANSISTOR 2SC2785

Note: The components identified by mark △ or dotted line with mark △ are critical for safety. Replace only with part number specified.

Ref.No.	Part No.	Description
Q505	8-729-104-91	TRANSISTOR 2SA1383
Q506	8-729-107-26	TRANSISTOR 2SD1585-K
Q507	△8-729-104-18	TRANSISTOR 2SC3514
Q508	△8-729-107-53	TRANSISTOR 2SC2275A
Q509	△8-729-190-53	TRANSISTOR 2SA985A
Q510	△8-729-300-36	TRANSISTOR 2SC2921
Q511	△8-729-300-22	TRANSISTOR 2SA1215
Q512	8-729-108-05	TRANSISTOR 2SC1841-PA
Q513	△8-729-178-54	TRANSISTOR 2SC2785
Q514	△8-729-117-54	TRANSISTOR 2SA1175
Q600	△8-729-108-14	TRANSISTOR 2SA988-F
Q601	△8-729-697-92	TRANSISTOR 2SA979
Q602	△8-729-178-54	TRANSISTOR 2SC2785
Q603	8-729-201-56	TRANSISTOR 2SK246GR2
Q604	△8-729-178-54	TRANSISTOR 2SC2785
Q605	8-729-104-91	TRANSISTOR 2SA1383
Q606	8-729-107-26	TRANSISTOR 2SD1585-K
Q607	△8-729-104-18	TRANSISTOR 2SC3514
Q608	△8-729-107-53	TRANSISTOR 2SC2275A-P
Q609	△8-729-190-53	TRANSISTOR 2SA985A-P
Q610	△8-729-300-36	TRANSISTOR 2SC2921
Q611	△8-729-300-22	TRANSISTOR 2SA1215
Q612	8-729-108-05	TRANSISTOR 2SC1841-PA
Q613	△8-729-178-54	TRANSISTOR 2SC2785
Q614	△8-729-117-54	TRANSISTOR 2SA1175
Q700	8-729-900-63	TRANSISTOR DTA124ES
Q900	8-729-900-36	TRANSISTOR DTC124ES
Q901	8-729-900-65	TRANSISTOR DTA114ES
Q902	8-729-900-65	TRANSISTOR DTA144ES
R11	1-249-411-11	CARBON 330 5% 1/4W
R12	1-249-416-11	CARBON 820 5% 1/4W
R13	1-249-413-11	CARBON 470 5% 1/4W
R14	1-249-414-11	CARBON 560 5% 1/4W
R15	1-249-441-11	CARBON 100K 5% 1/4W
R16	1-249-433-11	CARBON 22K 5% 1/4W
R17	1-249-411-11	CARBON 330 5% 1/4W
R100	1-249-417-11	(West Germany)...CARBON 1K 5% 1/4W
R101	1-249-417-11	(West Germany)...CARBON 1K 5% 1/4W
R102	1-247-700-11	CARBON 100 5% 1/4W
R103	1-249-469-11	CARBON 100K 5% 1/4W
R104	1-249-405-11	(West Germany)...CARBON 100 5% 1/4W
R104	1-249-411-11	(AEP,UK,E).....CARBON 330 5% 1/4W
R105	1-249-441-11	CARBON 100K 5% 1/4W
R106	1-249-417-11	CARBON 1K 5% 1/4W
R107	1-249-417-11	CARBON 1K 5% 1/4W
R108	1-249-405-11	(AEP,UK,E).....CARBON 100 5% 1/4W
R108	1-249-407-11	(West Germany)...CARBON 150 5% 1/4W
R109	1-249-415-11	CARBON 680 5% 1/4W
R110	1-249-457-11	CARBON 6.8 5% 1/4W
R111	1-247-700-11	CARBON 100 5% 1/4W
R112	1-247-903-00	CARBON 1M 5% 1/4W
R113	1-249-493-11	CARBON 56K 5% 1/2W
R114	1-247-760-11	CARBON 4.7K 5% 1/2W
R115	1-249-409-11	CARBON 220 5% 1/4W
R116	1-249-441-11	CARBON 100K 5% 1/4W
R117	1-249-420-11	CARBON 1.8K 5% 1/4W

Ref.No.	Part No.	Description
R118	1-247-903-00	CARBON 1M 5% 1/4W
R119	1-247-903-00	CARBON 1M 5% 1/4W
R120	1-247-903-00	CARBON 1M 5% 1/4W
R121	1-247-903-00	CARBON 1M 5% 1/4W
R122	1-247-903-00	CARBON 1M 5% 1/4W
R123	1-247-903-00	CARBON 1M 5% 1/4W
R124	1-247-903-00	CARBON 1M 5% 1/4W
R125	1-249-413-11	(West Germany)...CARBON 470 5% 1/4W
R126	1-249-413-11	(West Germany)...CARBON 470 5% 1/4W
R127	1-249-413-11	(West Germany)...CARBON 470 5% 1/4W
R128	1-249-413-11	CARBON 470 5% 1/4W
R129	1-249-413-11	(West Germany)...CARBON 470 5% 1/4W
R130	1-249-413-11	CARBON 470 5% 1/4W
R131	1-249-413-11	(West Germany)...CARBON 470 5% 1/4W
R150	1-247-891-00	CARBON 330K 5% 1/4W
R151	1-247-832-11	CARBON 1.1K 5% 1/4W
R152	1-249-413-11	CARBON 470 5% 1/4W
R153	1-247-903-00	CARBON 1M 5% 1/4W
R154	1-249-415-11	CARBON 680 5% 1/4W
R156	1-249-429-11	CARBON 10K 5% 1/4W
R157	1-249-417-11	CARBON 1K 5% 1/4W
R200	1-249-417-11	(West Germany)...CARBON 1K 5% 1/4W
R201	1-249-417-11	(West Germany)...CARBON 1K 5% 1/4W
R202	1-247-700-11	CARBON 100 5% 1/4W
R203	1-249-469-11	CARBON 100K 5% 1/4W
R204	1-249-405-11	(West Germany)...CARBON 100 5% 1/4W
R204	1-249-411-11	(AEP,UK,E).....CARBON 330 5% 1/4W
R205	1-249-441-11	CARBON 100K 5% 1/4W
R206	1-249-417-11	CARBON 1K 5% 1/4W
R207	1-249-417-11	CARBON 1K 5% 1/4W
R208	1-249-405-11	(AEP,UK,E).....CARBON 100 5% 1/4W
R208	1-249-407-11	(West Germany)...CARBON 150 5% 1/4W
R209	1-249-415-11	CARBON 680 5% 1/4W
R210	1-249-457-11	CARBON 6.8 5% 1/4W
R211	1-247-700-11	CARBON 100 5% 1/4W
R212	1-247-903-00	CARBON 1M 5% 1/4W
R213	1-249-493-11	CARBON 56K 5% 1/2W
R214	1-247-760-11	CARBON 4.7K 5% 1/2W
R215	1-249-409-11	CARBON 220 5% 1/4W
R216	1-249-441-11	CARBON 100K 5% 1/4W
R218	1-247-903-00	CARBON 1M 5% 1/4W
R219	1-247-903-00	CARBON 1M 5% 1/4W
R220	1-247-903-00	CARBON 1M 5% 1/4W
R221	1-247-903-00	CARBON 1M 5% 1/4W
R222	1-247-903-00	CARBON 1M 5% 1/4W
R223	1-247-903-00	CARBON 1M 5% 1/4W
R224	1-247-903-00	CARBON 1M 5% 1/4W
R225	1-249-413-11	(West Germany)...CARBON 470 5% 1/4W
R226	1-249-413-11	(West Germany)...CARBON 470 5% 1/4W
R227	1-249-413-11	(West Germany)...CARBON 470 5% 1/4W
R228	1-249-413-11	CARBON 470 5% 1/4W
R229	1-249-413-11	(West Germany)...CARBON 470 5% 1/4W
R230	1-249-413-11	CARBON 470 5% 1/4W
R231	1-249-413-11	(West Germany)...CARBON 470 5% 1/4W
R250	1-247-891-00	CARBON 330K 5% 1/4W
R251	1-247-832-11	CARBON 1.1K 5% 1/4W

Note: The components identified by mark △ or dotted line with mark △ are critical for safety. Replace only with part number specified.

Ref.No.	Part No.	Description				
R252	1-249-413-11	CARBON	470	5%	1/4W	
R253	1-247-903-00	CARBON	1M	5%	1/4W	
R254	1-249-415-11	CARBON	680	5%	1/4W	
R256	1-249-429-11	CARBON	10K	5%	1/4W	
R257	1-249-417-11	CARBON	1K	5%	1/4W	
R300	1-247-903-00	CARBON	1M	5%	1/4W	
R301	1-249-437-11	CARBON	47K	5%	1/4W	
R302	1-247-903-00	CARBON	1M	5%	1/4W	
R303	1-249-431-11	CARBON	15K	5%	1/4W	
R304	1-249-417-11	CARBON	1K	5%	1/4W	
R305	1-247-887-00	CARBON	220K	5%	1/4W	
R306	1-249-429-11	CARBON	10K	5%	1/4W	
R307	1-247-887-00	CARBON	220K	5%	1/4W	
R308	1-247-725-11	CARBON	10K	5%	1/4W	
R309	1-247-713-11	CARBON	1K	5%	1/4W	
R310	1-249-426-11	CARBON	5.6K	5%	1/4W	
R311	1-249-411-11	CARBON	330	5%	1/4W	
R312	1-249-414-11	CARBON	560	5%	1/4W	
R313	1-249-434-11	CARBON	27K	5%	1/4W	
R314	1-249-422-11	CARBON	2.7K	5%	1/4W	
R350	1-249-417-11	(West Germany)...CARBON	1K	5%	1/4W	
R400	1-247-903-00	CARBON	1M	5%	1/4W	
R401	1-249-437-11	CARBON	47K	5%	1/4W	
R402	1-247-903-00	CARBON	1M	5%	1/4W	
R403	1-249-431-11	CARBON	15K	5%	1/4W	
R404	1-249-417-11	CARBON	1K	5%	1/4W	
R405	1-247-887-00	CARBON	220K	5%	1/4W	
R406	1-249-429-11	CARBON	10K	5%	1/4W	
R407	1-247-887-00	CARBON	220K	5%	1/4W	
R408	1-247-725-11	CARBON	10K	5%	1/4W	
R409	1-247-713-11	CARBON	1K	5%	1/4W	
R410	1-249-426-11	CARBON	5.6K	5%	1/4W	
R411	1-249-411-11	CARBON	330	5%	1/4W	
R412	1-249-414-11	CARBON	560	5%	1/4W	
R413	1-249-434-11	CARBON	27K	5%	1/4W	
R414	1-249-422-11	CARBON	2.7K	5%	1/4W	
R450	1-249-417-11	(West Germany)...CARBON	1K	5%	1/4W	
R500	1-249-417-11	CARBON	1K	5%	1/4W	
R501	1-249-435-11	CARBON	33K	5%	1/4W	
R502	1-249-421-11	CARBON	2.2K	5%	1/4W	
R503	1-249-405-11	(E)....CARBON	100	5%	1/4W	
R503	1-249-406-11	(AEP,UK,West Germany) ...CARBON	120	5%	1/4W	
R504	△.1-247-704-11	CARBON	220	5%	1/4W	F
R505	△.1-247-704-11	CARBON	220	5%	1/4W	F
R506	1-249-429-11	CARBON	10K	5%	1/4W	
R507	1-249-435-11	CARBON	33K	5%	1/4W	
R508	1-249-433-11	CARBON	22K	5%	1/4W	
R509	1-249-429-11	(AEP,UK,West Germany) ...CARBON	10K	5%	1/4W	
R509	1-249-432-11	(E)....CARBON	18K	5%	1/4W	
R510	1-249-411-11	CARBON	330	5%	1/4W	
R511	1-249-435-11	CARBON	33K	5%	1/4W	
R512	1-249-420-11	(E)....CARBON	1.8K	5%	1/4W	
R512	1-249-422-11	(AEP,UK,West Germany) ...CARBON	2.7K	5%	1/4W	

Ref.No.	Part No.	Description				
R513	△.1-247-692-11	CARBON	22	5%	1/4W	F
R514	1-249-419-11	CARBON	1.5K	5%	1/4W	
R515	1-249-437-11	CARBON	47K	5%	1/4W	
R516	1-249-414-11	CARBON	560	5%	1/4W	
R517	△.1-247-692-11	CARBON	22	5%	1/4W	F
R518	△.1-247-700-11	CARBON	100	5%	1/4W	F
R519	△.1-247-700-11	CARBON	100	5%	1/4W	F
R520	△.1-247-739-11	(AEP,UK,West Germany) ...CARBON	100	5%	1/2W	F
R520	△.1-247-745-11	(E)...CARBON	330	5%	1/2W	F
R521	△.1-214-789-00	RES, METAL PLATE 0.1		5W		F
R522	△.1-214-789-00	RES, METAL PLATE 0.1		5W		F
R523	△.1-247-704-11	CARBON	220	5%	1/4W	F
R524	1-249-429-11	(AEP,UK,West Germany) ...CARBON	10K	5%	1/4W	
R524	1-249-436-11	(E)...CARBON	39K	5%	1/4W	
R525	1-247-688-11	CARBON	10	5%	1/4W	
R526	1-247-727-11	CARBON	10	5%	1/2W	
R527	1-249-437-11	CARBON	47K	5%	1/4W	
R528	1-249-482-11	(West Germany)...CARBON	4.7	5%	1/2W	
R529	1-249-482-11	(West Germany)...CARBON	4.7	5%	1/2W	
R530	△.1-215-869-11	(E)... METAL OXIDE	1K	5%	1W	F
R530	△.1-216-431-11	(AEP,UK,West Germany) ...METAL OXIDE	560	5%	1W	F
R531	△.1-247-719-11	(E)....CARBON	3.3K	5%	1/4W	F
R531	△.1-247-720-11	(AEP,UK,West Germany) ...CARBON	3.9K	5%	1/4W	F
R532	△.1-247-713-11	CARBON	1K	5%	1/4W	F
R533	△.1-247-713-11	CARBON	1K	5%	1/4W	F
R534	△.1-247-719-11	(E)....CARBON	3.3K	5%	1/4W	F
R534	△.1-247-720-11	(AEP,UK,West Germany) ...CARBON	3.9K	5%	1/4W	F
R535	△.1-247-688-11	CARBON	10	5%	1/4W	F
R536	△.1-247-688-11	CARBON	10	5%	1/4W	F
R600	1-249-417-11	CARBON	1K	5%	1/4W	
R601	1-249-435-11	CARBON	33K	5%	1/4W	
R602	1-249-421-11	CARBON	2.2K	5%	1/4W	
R603	1-249-405-11	(E)....CARBON	100	5%	1/4W	
R603	1-249-406-11	(AEP,UK,West Germany) ...CARBON	120	5%	1/4W	
R604	△.1-247-704-11	CARBON	220	5%	1/4W	F
R605	△.1-247-704-11	CARBON	220	5%	1/4W	F
R606	1-249-429-11	CARBON	10K	5%	1/4W	
R607	1-249-435-11	CARBON	33K	5%	1/4W	
R608	1-249-433-11	CARBON	22K	5%	1/4W	
R609	1-249-429-11	(AEP,UK,West Germany) ...CARBON	10K	5%	1/4W	
R609	1-249-432-11	(E)....CARBON	18K	5%	1/4W	
R610	1-249-411-11	CARBON	330	5%	1/4W	
R611	1-249-435-11	CARBON	33K	5%	1/4W	
R612	1-249-420-11	(E)....CARBON	1.8K	5%	1/4W	
R612	1-249-422-11	(AEP,UK,West Germany) ...CARBON	2.7K	5%	1/4W	
R613	△.1-247-692-11	CARBON	22	5%	1/4W	F
R614	1-249-419-11	CARBON	1.5K	5%	1/4W	
R615	1-249-437-11	CARBON	47K	5%	1/4W	
R616	1-249-414-11	CARBON	560	5%	1/4W	

Note: The components identified by mark △ or dotted line with mark △ are critical for safety. Replace only with part number specified.

Ref.No.	Part No.	Description				
R617	△.1-247-692-11	CARBON	22	5%	1/4W	F
R618	△.1-247-700-11	CARBON	100	5%	1/4W	F
R619	△.1-247-700-11	CARBON	100	5%	1/4W	F
R620	△.1-247-739-11	(AEP,UK,West Germany) ...CARBON	100	5%	1/2W	F
R620	△.1-247-745-11	(E).....CARBON	330	5%	1/2W	F
R621	△.1-214-789-00	RES, METAL PLATE 0.1		5W		F
R622	△.1-214-789-00	RES, METAL PLATE 0.1		5W		F
R623	△.1-247-704-11	CARBON	220	5%	1/4W	F
R624	1-249-429-11	(AEP,UK,West Germany) ...CARBON	10K	5%	1/4W	
R624	1-249-436-11	(E).....CARBON	39K	5%	1/4W	
R625	1-247-688-11	CARBON	10	5%	1/4W	
R626	1-247-727-11	CARBON	10	5%	1/2W	
R627	1-249-438-11	CARBON	56K	5%	1/4W	
R628	1-249-482-11	(West Germany)...CARBON	4.7	5%	1/2W	
R629	1-249-482-11	(West Germany)...CARBON	4.7	5%	1/2W	
R630	△.1-215-869-11	(E)...METAL OXIDE	1K	5%	1W	F
R630	△.1-216-431-11	(AEP,UK,West Germany) ...METAL OXIDE	560	5%	1W	F
R631	△.1-247-719-11	(E).....CARBON	3.3K	5%	1/4W	F
R631	△.1-247-720-11	(AEP,UK,West Germany) ...CARBON	3.9K	5%	1/4W	F
R632	△.1-247-713-11	CARBON	1K	5%	1/4W	F
R633	△.1-247-713-11	CARBON	1K	5%	1/4W	F
R634	△.1-247-719-11	(E).....CARBON	3.3K	5%	1/4W	F
R634	△.1-247-720-11	(AEP,UK,West Germany) ...CARBON	3.9K	5%	1/4W	F
R635	△.1-247-688-11	CARBON	10	5%	1/4W	F
R636	△.1-247-688-11	CARBON	10	5%	1/4W	F
R700	1-249-427-11	CARBON	6.8K	5%	1/4W	
R701	1-249-441-11	CARBON	100K	5%	1/4W	
R702	1-249-421-11	CARBON	2.2K	5%	1/4W	
R703	1-249-437-11	CARBON	47K	5%	1/4W	
R704	1-249-431-11	(AEP,UK,West Germany) ...CARBON	15K	5%	1/4W	
R704	1-249-433-11	(E).....CARBON	22K	5%	1/4W	
R705	△.1-215-917-11	(E).....METAL OXIDE	1K	5%	3W	F
R705	△.1-216-479-11	(AEP,UK,West Germany) ...METAL OXIDE	560	5%	3W	F
R800	△.1-215-914-11	(AEP,UK,West Germany) ...METAL OXIDE	330	5%	3W	F
R800	△.1-215-916-11	(E).....METAL OXIDE	680	5%	3W	F
R801	△.1-206-718-00	(AEP,UK,West Germany) ...METAL OXIDE	510	5%	3W	F
R801	△.1-215-917-11	(E).....METAL OXIDE	1K	5%	3W	F



Ref.No.	Part No.	Description				
R802	△.1-247-688-11	CARBON	10	5%	1/4W	F
R803	△.1-247-688-11	CARBON	10	5%	1/4W	F
R804	1-247-723-11	(AEP,UK,West Germany) ...CARBON	6.8K	5%	1/4W	
R804	1-247-725-11	(E).....CARBON	10K	5%	1/4W	
R805	1-249-417-11	CARBON	1K	5%	1/4W	
R900	1-247-804-11	CARBON	75	5%	1/4W	
R901	1-247-804-11	CARBON	75	5%	1/4W	
R902	1-247-806-11	CARBON	91	5%	1/4W	
R903	1-249-437-11	CARBON	47K	5%	1/4W	
R904	1-249-437-11	CARBON	47K	5%	1/4W	
R905	1-249-421-11	CARBON	2.2K	5%	1/4W	
R906	1-249-421-11	CARBON	2.2K	5%	1/4W	
R907	1-249-417-11	CARBON	1K	5%	1/4W	
R908	1-249-417-11	CARBON	1K	5%	1/4W	
R909	1-249-417-11	CARBON	1K	5%	1/4W	
R910	1-249-429-11	CARBON	10K	5%	1/4W	
R911	1-249-429-11	CARBON	10K	5%	1/4W	
R912	1-249-429-11	CARBON	10K	5%	1/4W	
R913	1-249-421-11	CARBON	2.2K	5%	1/4W	
R914	1-247-820-11	CARBON	360	5%	1/4W	
R920	1-249-405-11	CARBON	100	5%	1/4W	
R921	1-247-903-00	CARBON	1M	5%	1/4W	
R922	1-249-393-11	CARBON	10	5%	1/4W	
R923	1-249-441-11	CARBON	100K	5%	1/4W	
R924	1-249-417-11	CARBON	1K	5%	1/4W	
R925	1-249-417-11	CARBON	1K	5%	1/4W	
R926	1-249-405-11	CARBON	100	5%	1/4W	
R927	1-249-405-11	CARBON	100	5%	1/4W	
R928	1-249-405-11	CARBON	100	5%	1/4W	
R930	1-249-405-11	CARBON	100	5%	1/4W	
R931	1-249-405-11	CARBON	100	5%	1/4W	
R932	1-249-405-11	CARBON	100	5%	1/4W	
R933	1-249-413-11	CARBON	470	5%	1/4W	
R950	△.1-249-452-11	CARBON	2.7	5%	1/4W	F
R951	△.1-249-452-11	CARBON	2.7	5%	1/4W	F
R959	△.1-213-074-11	FUSIBLE	39	5%	1W	F
R960	1-249-437-11	CARBON	47K	5%	1/4W	
R961	1-249-421-11	CARBON	2.2K	5%	1/4W	
R962	1-249-441-11	CARBON	100K	5%	1/4W	
R963	1-249-441-11	CARBON	100K	5%	1/4W	
R980	1-249-421-11	CARBON	2.2K	5%	1/4W	
R981	1-249-429-11	CARBON	10K	5%	1/4W	
R982	1-249-425-11	CARBON	4.7K	5%	1/4W	

Note: The components identified by mark △ or dotted line with mark △ are critical for safety. Replace only with part number specified.

Ref.No.	Part No.	Description
R983	1-249-425-11	CARBON 4.7K 5% 1/4W
R984	1-249-429-11	CARBON 10K 5% 1/4W
R985	1-249-429-11	CARBON 10K 5% 1/4W
RV300	1-237-741-11	RES, VAR, CARBON 250K/250K (VOLUME)
RV301	1-237-739-11	RES, VAR, CARBON 100K/100K (BALANCE)
RV302	1-237-740-11	RES, VAR, CARBON 100K/100K (TREBLE)
RV303	1-237-740-11	RES, VAR, CARBON 100K/100K (BASS)
RX900	1-464-931-11	RECEIVE UNIT, RAY (OPTICAL)
RY700	1-515-356-00	RELAY
S1	△.1-554-880-11	SWITCH, PUSH (AC POWER)(1 KEY)(POWER)
S10	1-571-701-11	SWITCH, ROTARY (INPUT SELECTOR)
S100	1-571-111-11	SWITCH, PUSH (1 KEY)(CARTRIDGE)
S101	1-571-115-11	SWITCH, SLIDE (REC OUT SELECTOR)
S102	1-571-669-11	SWITCH, SLIDE (INPUT SELECTOR)
S301	1-571-702-11	SWITCH, PUSH (3 KEY) (SUBSONIC, LOUDNESS, ANALOG/DEGITAL)
S302	1-571-671-11	SWITCH, PUSH (1 KEY)(CD DIRECT)
S303	1-571-112-11	SWITCH, PUSH (1 KEY)(TONE)
S500	1-571-109-11	SWITCH, ROTARY SLIDE (SPEAKERS)
T1	△.1-449-432-11	(AEP, UK, West Germany) ...TRANSFORMER, POWER
T1	△.1-449-433-11	(E).....TRANSFORMER, POWER
TB1	*1-535-139-00	(AEP, West Germany)...BASE POST 22MM (10MM PITCH) 2P
TB1	*1-535-141-00	(E)...BASE POST 22MM (10MM PITCH) 4P
TB2	*1-535-139-00	(UK, E)...BASE POST 22MM (10MM PITCH) 2P
TB3	*1-535-140-00	(E)...BASE POST 22MM (10MM PITCH) 3P
TB4	*1-535-140-00	(E)...BASE POST 22MM (10MM PITCH) 3P
TB4	*1-535-142-00	(AEP, West Germany)...BASE POST 22MM (10MM PITCH) 5P
TB5	*1-535-116-00	TERMINAL 3P
TB7	*1-535-117-00	TERMINAL 4P
TB8	*1-535-115-00	TERMINAL 2P
TB9	*1-535-115-00	TERMINAL 2P
TB10	*1-535-117-00	TERMINAL 4P
TB11	*1-535-117-00	TERMINAL 4P
TM501	1-536-662-00	TERMINAL BOARD (SPEAKER)
VS1	△.1-570-307-11	(E)...SWITCH, VOLTAGE CHANGE
X900	1-577-259-11	VIBRATOR, CRYSTAL 17MHZ

ACCESSORY & PACKING MATERIAL

1-559-847-11	CORD, CONNECTION
*3-704-350-01	SHEET (STANDARD), PROTECTION
3-786-495-11	(AEP, UK, E).....MANUAL, INSTRUCTION
3-786-495-41	(AEP, West Germany)...MANUAL, INSTRUCTION
*4-923-820-01	CUSHION
*4-923-839-01	(AEP, E, West Germany)...INDIVIDUAL CARTON
*4-923-839-11	(UK).....INDIVIDUAL CARTON

Note: The components identified by mark  or dotted line with mark  are critical for safety. Replace only with part number specified.

PARTS LIST
 ORDER PARTS FROM THE LIST BY QUANTITY AND PART NUMBER.
 PARTS LIST FOR THE MODEL IN THE TOP RIGHT CORNER OF THIS PAGE.
 PARTS LIST FOR THE MODEL IN THE TOP RIGHT CORNER OF THIS PAGE.
 PARTS LIST FOR THE MODEL IN THE TOP RIGHT CORNER OF THIS PAGE.
 PARTS LIST FOR THE MODEL IN THE TOP RIGHT CORNER OF THIS PAGE.
 PARTS LIST FOR THE MODEL IN THE TOP RIGHT CORNER OF THIS PAGE.
 PARTS LIST FOR THE MODEL IN THE TOP RIGHT CORNER OF THIS PAGE.
 PARTS LIST FOR THE MODEL IN THE TOP RIGHT CORNER OF THIS PAGE.
 PARTS LIST FOR THE MODEL IN THE TOP RIGHT CORNER OF THIS PAGE.
 PARTS LIST FOR THE MODEL IN THE TOP RIGHT CORNER OF THIS PAGE.
 PARTS LIST FOR THE MODEL IN THE TOP RIGHT CORNER OF THIS PAGE.

Part No.	Description	QTY	Remarks
1-201-111-01	UNIT, FRONT PANEL (LEFT)	1	
1-201-111-02	UNIT, FRONT PANEL (RIGHT)	1	
1-201-111-03	UNIT, FRONT PANEL (CENTER)	1	
1-201-111-04	UNIT, FRONT PANEL (LOWER LEFT)	1	
1-201-111-05	UNIT, FRONT PANEL (LOWER RIGHT)	1	
1-201-111-06	UNIT, FRONT PANEL (LOWER CENTER)	1	
1-201-111-07	UNIT, FRONT PANEL (LOWER LEFT)	1	
1-201-111-08	UNIT, FRONT PANEL (LOWER RIGHT)	1	
1-201-111-09	UNIT, FRONT PANEL (LOWER CENTER)	1	
1-201-111-10	UNIT, FRONT PANEL (LOWER LEFT)	1	
1-201-111-11	UNIT, FRONT PANEL (LOWER RIGHT)	1	
1-201-111-12	UNIT, FRONT PANEL (LOWER CENTER)	1	
1-201-111-13	UNIT, FRONT PANEL (LOWER LEFT)	1	
1-201-111-14	UNIT, FRONT PANEL (LOWER RIGHT)	1	
1-201-111-15	UNIT, FRONT PANEL (LOWER CENTER)	1	

Please refer to the back cover of the manual for the location of the parts.
 The location of the parts is shown in the diagram on page 32.
 The location of the parts is shown in the diagram on page 32.
 The location of the parts is shown in the diagram on page 32.
 The location of the parts is shown in the diagram on page 32.
 The location of the parts is shown in the diagram on page 32.
 The location of the parts is shown in the diagram on page 32.
 The location of the parts is shown in the diagram on page 32.
 The location of the parts is shown in the diagram on page 32.
 The location of the parts is shown in the diagram on page 32.
 The location of the parts is shown in the diagram on page 32.