

TA-F670ES

SERVICE MANUAL

AEP Model
UK Model



SPECIFICATIONS

Amplifier Section

Items	Condition		Data
			TA-F670ES
Continuous RMS power output (both channels driven simultaneously)	4 ohm, 20 Hz - 20 kHz	Countries other than North European countries	130 W + 130 W (THD 0.01%) (DIN: 180 W + 180 W)
		North European countries	100 W + 100 W (THD 0.006%) (DIN: 120 W + 120 W)
	8 ohms, 20 Hz - 20 kHz	Countries other than North European countries	100 W + 100 W (THD 0.004%) (DIN: 120 W + 120 W)
		North European countries	85 W + 85 W (THD 0.004%) (DIN: 105 W + 105 W)
Power band width (IHF)	8 ohms, THD 0.02%		10 Hz - 100 kHz at 45 W
Dynamic headroom ('78 IHF)	4 ohms		2 dB
	8 ohms		1.2 dB
Total harmonic distortion	8 ohms, at 10 watt output		0.004%
Intermodulation (IM) distortion 60 Hz : 7 kHz = 4 : 1	4 ohms, at rated output		0.008%
	6 ohms, at rated output		0.006%
	8 ohms, at rated output		0.004%
Damping factor	8 ohms, at 1 kHz		100
Residual noise	network A, 8 ohms		less than 100 μ V
Frequency response	PHONO MM		RIAA equalization curve ± 0.2 dB
	TUNER, GD TAPE 1,2,3, DIRECT IN		2 Hz - 200 kHz ± 3 dB
Input sensitivity	PHONO	MC	0.17 mV 100 ohms
		MM	2.5 mV, 50 kohms
	TUNER, CD, DIRECT IN, TAPE 1,2,3, ADAPTOR, AUX		150 mV, 20 kohms

Items	Condition		Data
			TA-F670ES
S/N (network) ('78 IHF)	PHONO	MC	77 (0.5 mV)
		MM	95 (5.0 mV)
	TUNER, CD, DIRECT IN, TAPE 1,2,3, ADAPTOR, AUX		105 (150 mV)
Output voltage impedance	REC OUT 1,2,3 ADAPTOR		150 mV, 1 kohm
	HEADPHONES		25 miliwatts (at 8 ohms) Accepts low and high impedance headphones.
Tone controls	BASS, at 100 Hz		± 7 dB
	TREBLE, at 10 kHz		± 6 dB
Subsonic filter	-		6 dB/octave attenuation below 15 Hz
Muting	-		-20dB

General

System Preamplifier section: Low-noise high gain NFB
 byte equalizer amplifier, passive type direct
 tone control
 Power amplifier section: Pure-complementary
 SEPP power amplifier,

Power requirements

UK model: 240V AC, 50 Hz
 AEP. G model: 220-230V AC, 50/60 Hz

— continued on next page —

INTEGRATED STEREO AMPLIFIER
SONY®

Power consumption

	TA-F670ES
UK model	700W
North European model	200W
European model	310W

Dimensions Approx. 430×150×375mm (w/h/d)
(17×5⁷/₈×14³/₄ inches)

weight Approx. 12.5kg (27 lbs 9 oz) net

Design and specifications subject to change without notice.

Note

This appliance conforms with EEC directive 87/308/EEC regarding interference suppression.

MODEL IDENTIFICATION

—Model Number Label—

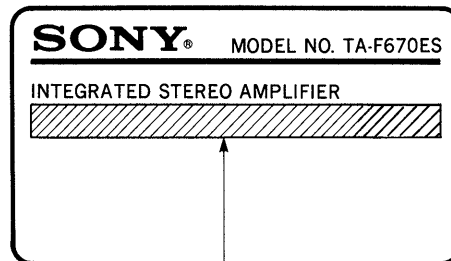



AEP model : AC 220V—230V~50/60Hz

Germany model: AC 230V~50/60Hz

UK model : AC 240V~50/60Hz

SAFETY-RELATED COMPONENT WARNING!!

COMPONENTS IDENTIFIED BY MARK  OR DOTTED LINE WITH MARK  ON THE SCHEMATIC DIAGRAMS AND IN THE PARTS LIST ARE CRITICAL TO SAFE OPERATION. REPLACE THESE COMPONENTS WITH SONY PARTS WHOSE PART NUMBERS APPEAR AS SHOWN IN THIS MANUAL OR IN SUPPLEMENTS PUBLISHED BY SONY.

Function of Controls

Front panel

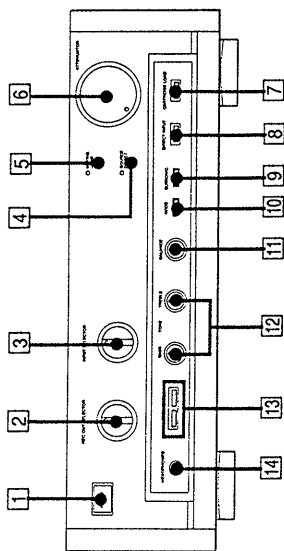

1 POWER switch and indicator

After the power is turned on, the standby indicator lights in red as the built-in muting circuit activates. When the amplifier stays in a stable operating condition, the indicator lights in green.

The indicator lights in red if the unit detects shorting of circuit of the speaker outputs or in case of short-circuit of the inputs of DC components. In such a case, disconnect the power source and check the connected components and speaker systems.

2 REC OUT SELECTOR

Selects the program source sent to the REC OUT jacks for recording.

3 INPUT SELECTOR

Selects the desired program source for listening.

4 SOURCE DIRECT button and indicator

Depress the button. The red indicator lights and the circuits of the TONE control, SUBSONIC filter button, BALANCE control and MODE selector are disengaged without regard to the setting of the switches.

5 MUTING button and indicator

Depress the button to reduce the sound level by 20 dB. (Output voltage becomes 1/10.) Generally, keep the button released (OFF).

6 ATTENUATOR

Adjusts the sound level. To increase the sound level, turn the control clockwise. To decrease the level, turn the control counterclockwise.

Note

Turn down the sound level before switching on the unit. This prevents damage to speakers.

7 CARTRIDGE LOAD selector

Set the selector according to your cartridge.

MM: For moving-magnet type cartridge

MC: For moving-coil type cartridge

8 DIRECT INPUT selector

Set to SOURCE to select program source with the INPUT SELECTOR.

To listen to a program source processed through the equipment, such as graphic equalizer, connected to the ADAPTOR jacks, set it to SOURCE.

To listen to a program source connected to DIRECT IN jacks, set it to DIRECT.

9 SUBSONIC filter button

Depress the button to reduce noise components of less than 15 Hz, which cause modulation noise.

10 MODE selector

STEREO: For listening to a stereo program.
MONO: For listening to a monaural program.

11 BALANCE control

Adjusts the sound level of left and right speakers.

12 BASS and TREBLE TONE controls

Adjust the tone quality.

To increase bass or treble sound, turn the control clockwise. To decrease them, turn the control counterclockwise.

13 SPEAKERS buttons

Select speaker system A or B, or both.

To drive speaker system A: Depress A button.

To drive speaker system B: Depress B button.

To drive speaker system A and B: Depress A and B.

To use power amplifier or active speaker system connected to the PRE OUT jacks, depress B/PRE OUT.

14 HEADPHONES jack

Accepts the stereo phone plug of headphones.

SECTION 1 GENERAL

This section is extracted from instruction manual.

SECTION 2 ELECTRICAL ADJUSTMENTS

Bias Adjustment

Note : Adjust the idling after tuning the unit on for about 10 minutes, giving it time to warm up.

Procedure :

1. Connect the digital voltmeter to VH5 on main board as follows.
2. Adjust RT301 (L-CL) and RT351 (R-CH) so that the digital voltmeter on signal reads 14mV at VH5.

Adjustment Location :

[MAIN BOARD]
(component side)

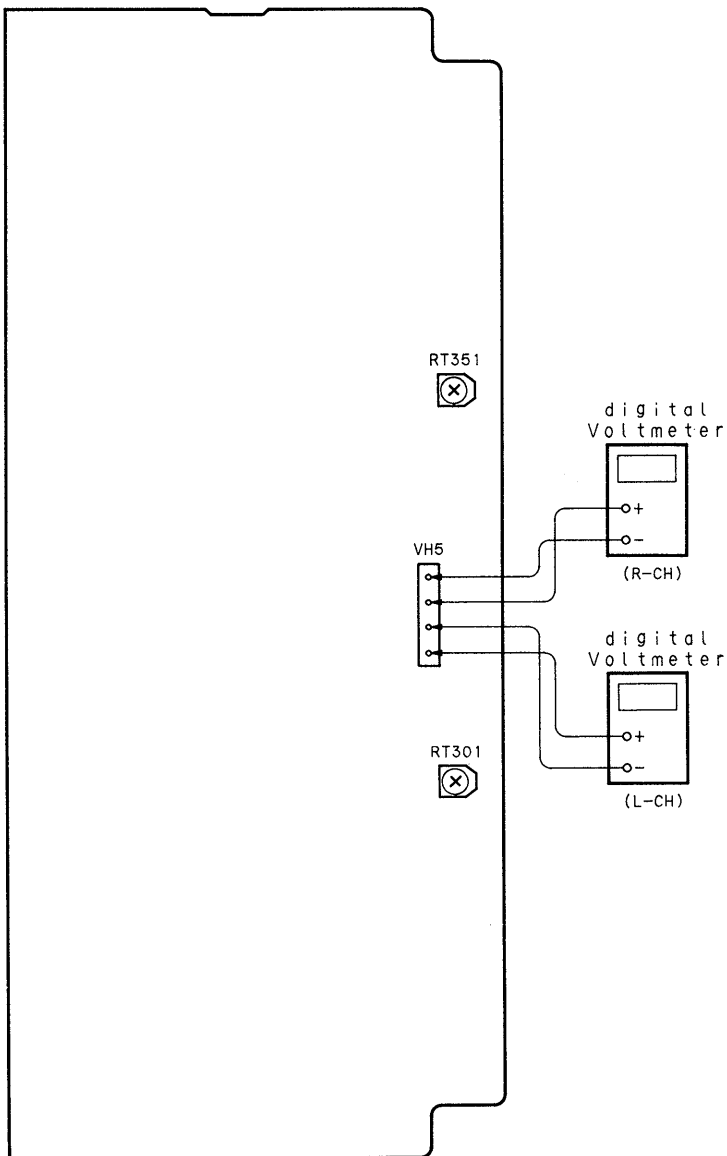

SECTION 3 DIAGRAMS

3-1. CIRCUIT BOARDS LOCATION

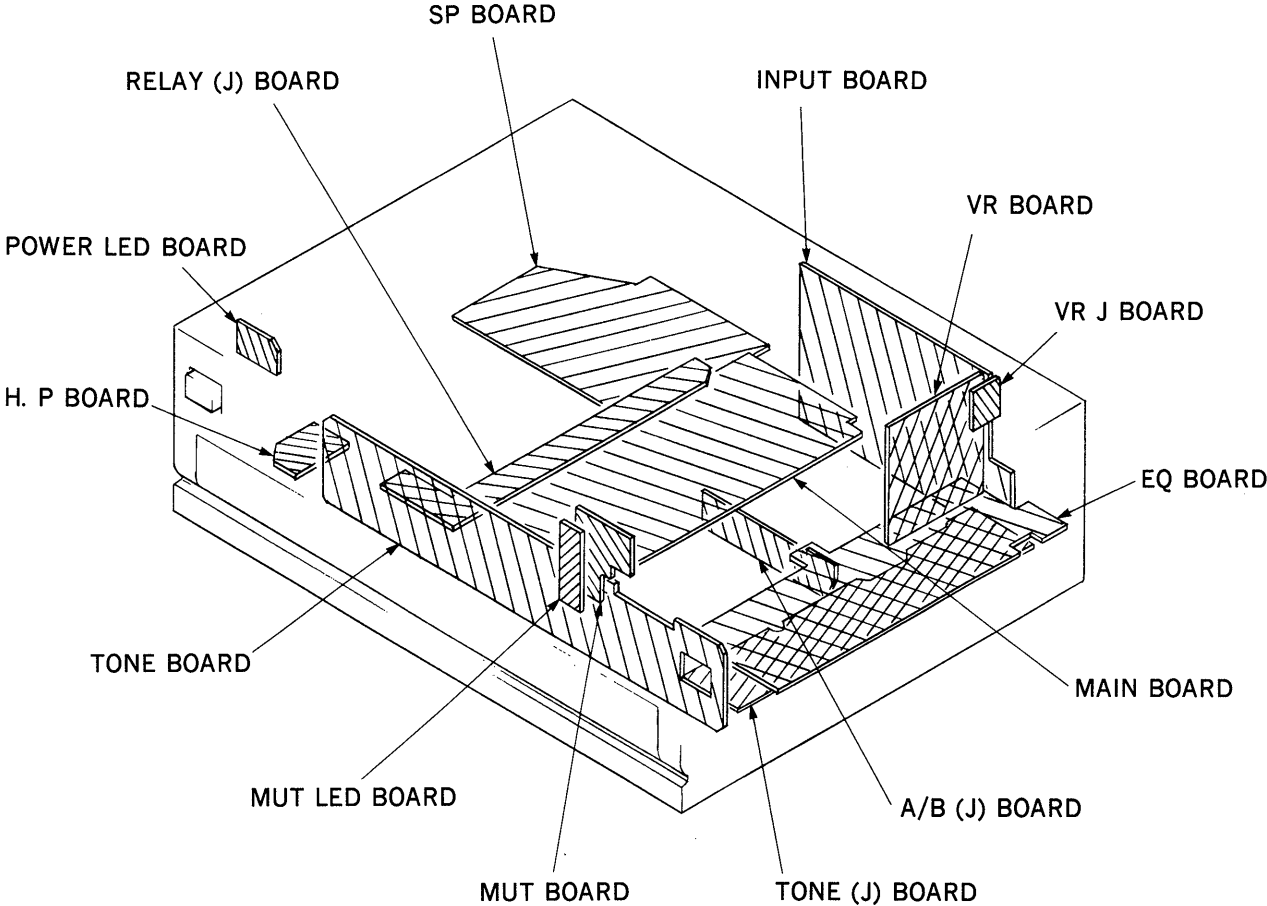

3-2. SEMICONDUCTOR LEAD LAYOUTS

RC4560DD

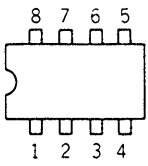

(Top view)

TA7815S

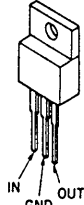

TA-7915S

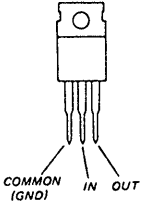

μPC1237HA

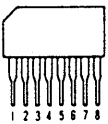

2SA733-QP
2SC945-P

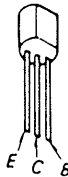

2SA985A-QP
2SC2275A-P

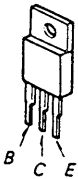

2SA988-PAFAEA
2SA1371-E
2SC2545-E

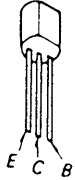

2SA1216M-OY
2SC2922M-OY



2SC1941-LK
2SD774-34

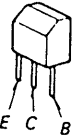

2SC2259-FG



2SC2603-EF

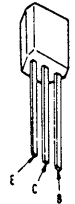

2SC3423-0

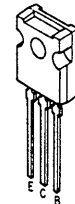

2SK246-GR2

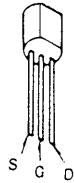

HZS6C3L
UZL-7M1
1SS120
11ES2

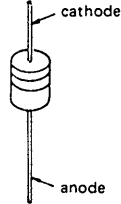

30DF2

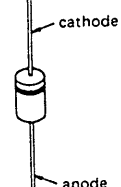

SEL1516W
SEL2810A

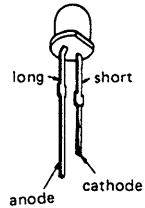

• Semiconductor Location

Location	Ref. No.	Location	Ref. No.
D301	H-19	Q302	G-19
D302	H-19	Q303	G-19
D303	H-19	Q304	H-18
D304	G-20	Q305	H-19
D305	G-20	Q306	H-19
D306	G-19	Q307	H-19
D307	I-22	Q308	H-20
D308	I-23	Q309	H-22
D309	J-23	Q310	H-23
D351	I-19	Q311	H-23
D352	I-19	Q312	I-22
D353	I-19	Q313	G-22
D354	J-20	Q314	J-23
D355	J-20	Q351	J-18
D356	J-19	Q352	J-19
D357	C-22	Q353	J-19
D358	C-23	Q354	I-18
D359	C-23	Q355	J-19
D401	F-19	Q356	J-19
D501	E-25	Q357	J-19
D502	E-25	Q358	I-20
D503	G-25	Q359	D-22
D504	G-25	Q360	D-23
D505	D-25	Q361	D-23
D506	E-25	Q362	C-22
D507	H-25	Q363	E-22
D508	H-26	Q364	B-23
D509	H-25	Q401	D-18
D510	H-25	Q402	D-18
D511	I-25	Q451	D-19
D512	F-3	Q452	D-19
D513	I-2	Q501	I-4
D514	I-2	Q502	I-3
D515	F-29	Q503	I-3
D516	F-30	Q504	I-2
D517	F-2	Q505	K-11
D518	H-5	Q506	K-12
D519	G-5		
D520	C-11		
D521	C-7		
IC401	E-19		
IC402	E-20		
IC403	F-20		
IC501	J-25		
Q301	G-18		

3-3. PRINTED WIRING BOARDS • Refer to page 6 for Semiconductor Lead Layouts and Semiconductor Location.

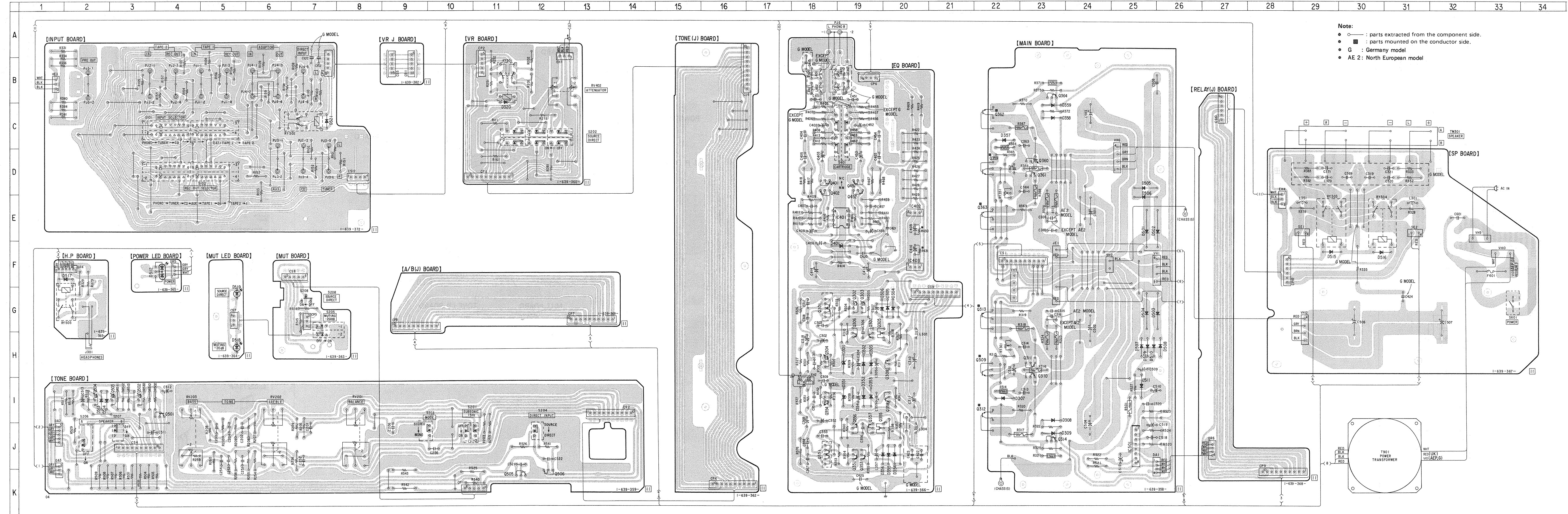

3-4. SCHEMATIC DIAGRAM

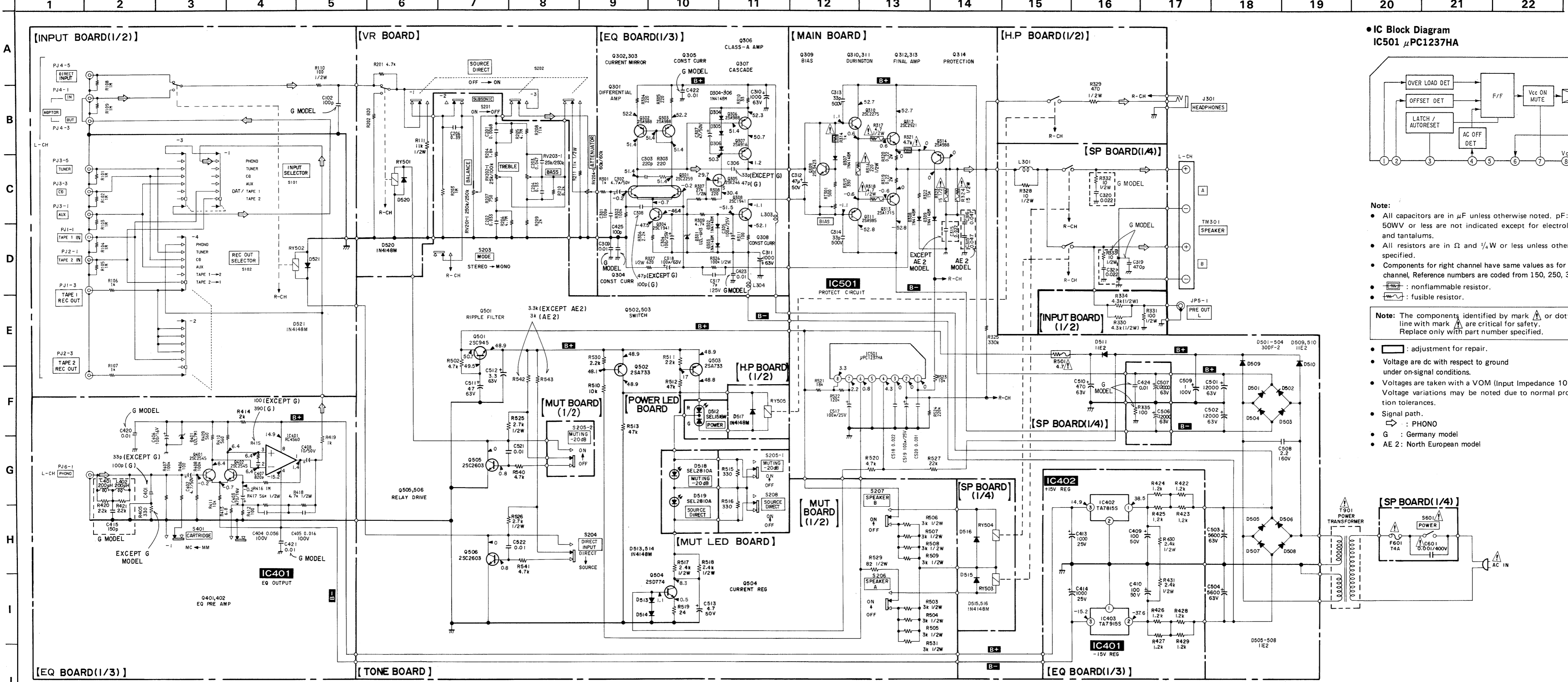

• IC Block Diagram
IC501 μ PC1237HA

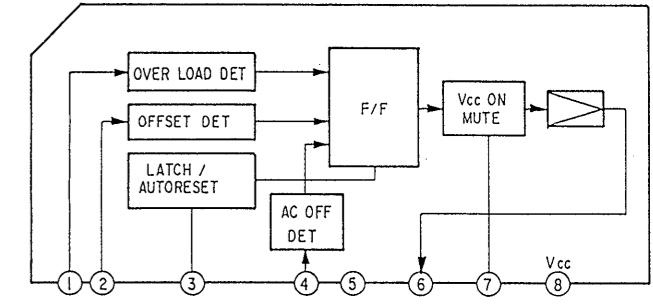

- Note:**
- All capacitors are in μ F unless otherwise noted. pF: μ F
 - 50WV or less are not indicated except for electrolytics and tantalums.
 - All resistors are in Ω and $1/8$ W or less unless otherwise specified.
 - Components for right channel have same values as for left channel. Reference numbers are coded from 150, 250, 350, 450.
 - : nonflammable resistor.
 - : fusible resistor.

Note: The components identified by mark or dotted line with mark are critical for safety. Replace only with part number specified.

- : adjustment for repair.
- Voltage are dc with respect to ground under on-signal conditions.
- Voltages are taken with a VOM (Input Impedance $10M\Omega$). Voltage variations may be noted due to normal production tolerances.
- Signal path.
- : PHONO
- G : Germany model
- AE 2 : North European model

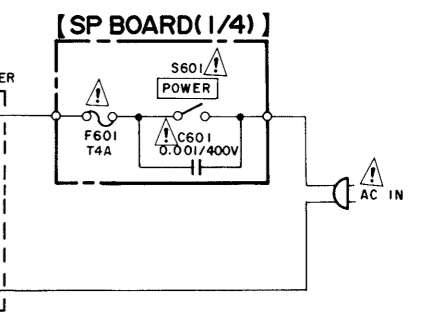

SECTION 4 EXPLODED VIEWS

NOTE:

- The mechanical parts with no reference number in the exploded views are not supplied.
- Items marked "*" are not stocked since they are seldom required for routine service. Some delay should be anticipated when ordering these items.

- -XX, -X mean standardized parts, so they may have some differences from the original one.

- Color Indication of Appearance Parts
Example:

KNOB, BALANCE (WHITE)...(RED)

↑

Parts Color

↑

Cabinet's Color

- Hardware(# mark) list is given in the last of this parts list.

The components identified by mark or dotted line with mark are critical for safety. Replace only with part number specified.

- G : Germany model
- AE 2: North European model

1. CABINET

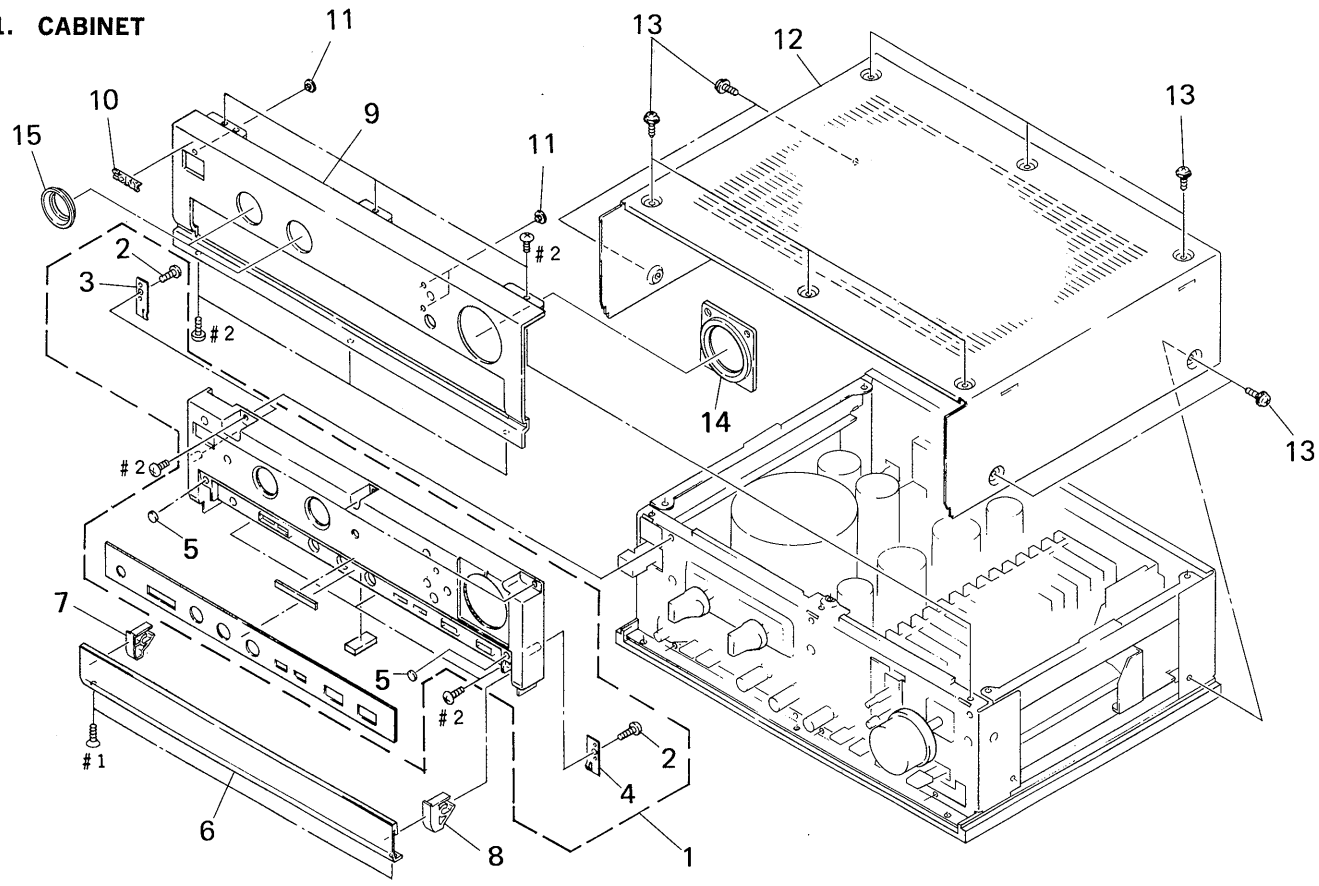

Ref. No.	Part No.	Description	Remark
1	X-4941-784-1	PANEL (BASE) ASSY	
2	4-928-635-01	SCREW, +BV (2. 6X8) TAPPING	
3	* 4-942-233-01	SPRING (L), PLATE	
4	* 4-942-234-01	SPRING (R), PLATE	
5	4-879-274-01	SPACER	
6	4-946-346-01	LID	
7	4-942-225-01	ARM (L)	
8	4-942-226-01	ARM (R)	
9	4-946-348-31	PANEL, FRONT (AEP, G)	
9	4-946-348-41	PANEL, FRONT (UK)	

Ref. No.	Part No.	Description	Remark
10	4-908-848-01	EMBLEM, SONY	
11	4-931-646-01	LENS, LED	
12	* 4-946-347-01	CASE (AE1, G, UK)	
12	* 4-946-347-11	CASE (AE2)	
13	3-704-366-01	SCREW (CASE) (M3X8)	
14	4-946-324-01	RING (LARGE), ORNAMENTAL	
15	4-946-325-01	RING (SMALL), ORNAMENTAL	

2. SUB CHASSIS

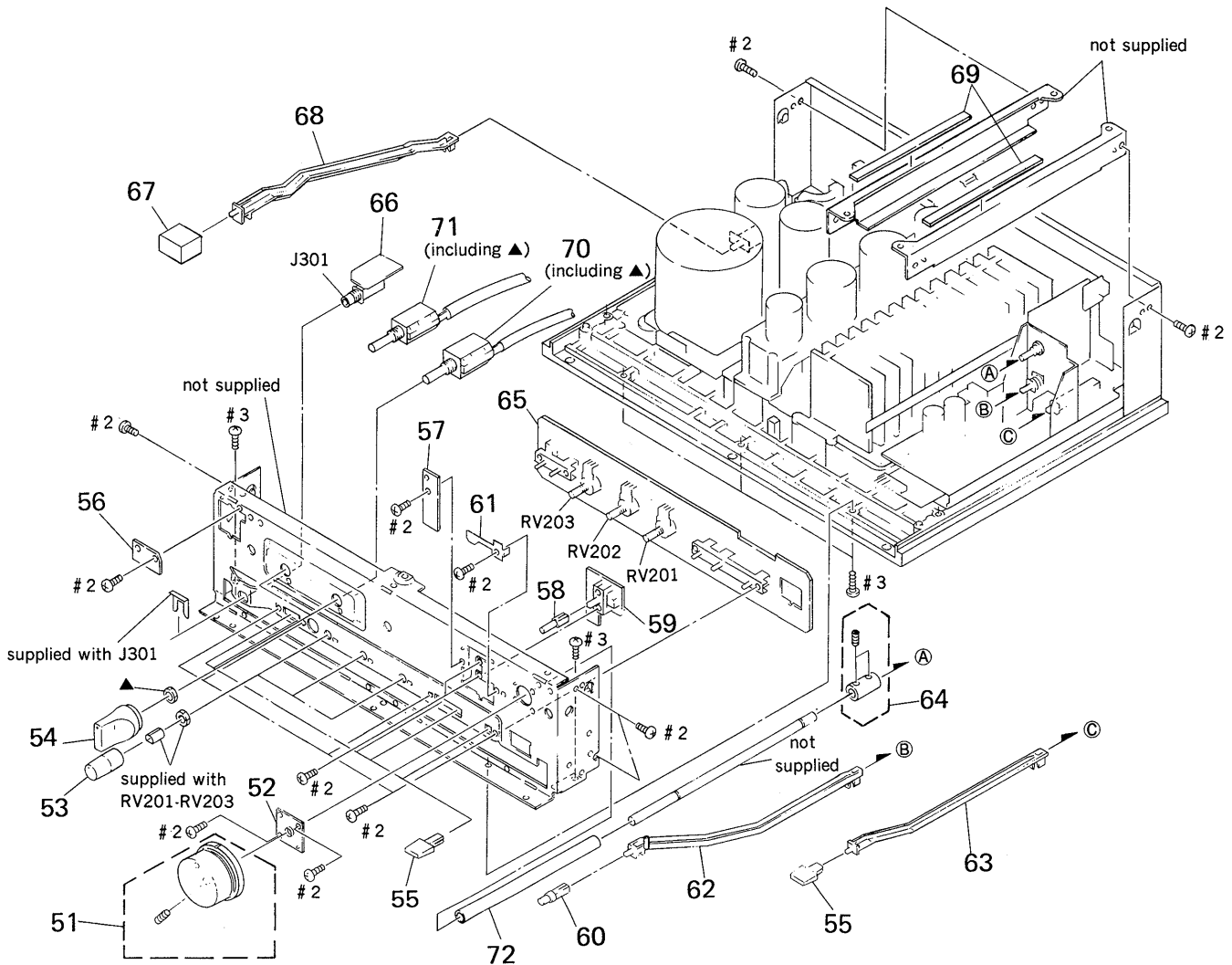

Ref. No.	Part No.	Description	Remark	Ref. No.	Part No.	Description	Remark
51	4-946-323-01	KNOB (VOL-L)		64	* 4-946-330-01	JOINT	
52	4-946-335-01	BRACKET (BEARING)		65	* 1-639-362-11	TONE (J) BOARD	
53	4-946-333-01	KNOB (TONE)		66	* 1-639-361-11	H. P BOARD	
54	4-945-601-01	KNOB (F25)		67	4-942-032-01	KNOB (POWER)	
55	4-942-228-01	KNOB (3X13)		68	4-946-340-01	ROD (P)	
56	* 1-639-365-11	POWER LED BOARD		69	* 4-916-782-21	DAMPER	
57	* 1-639-364-11	MUT LED BOARD		70	1-572-742-11	SWITCH, ROTARY	
58	4-931-641-01	BUTTON (DIA. 4)		71	1-572-743-11	SWITCH, ROTARY	
59	* 1-639-363-11	MUT BOARD		72	4-946-322-01	SLEEVE	
60	4-931-926-01	BUTTON (B)		J301	1-507-796-71	JACK (HEADPHONES)	
61	4-946-732-01	SPRING (S), LEAF		RV201	1-241-517-11	RES. VAR. CARBON 250K/250K (BALANCE)	
62	4-946-339-01	ROD (S)		RV202	1-241-518-11	RES. VAR. CARBON 25K/100K (TREBLE)	
63	4-946-338-01	ROD (C)		RV203	1-241-519-11	RES. VAR. CARBON 25K/250K (BASS)	

3. MAIN CHASSIS

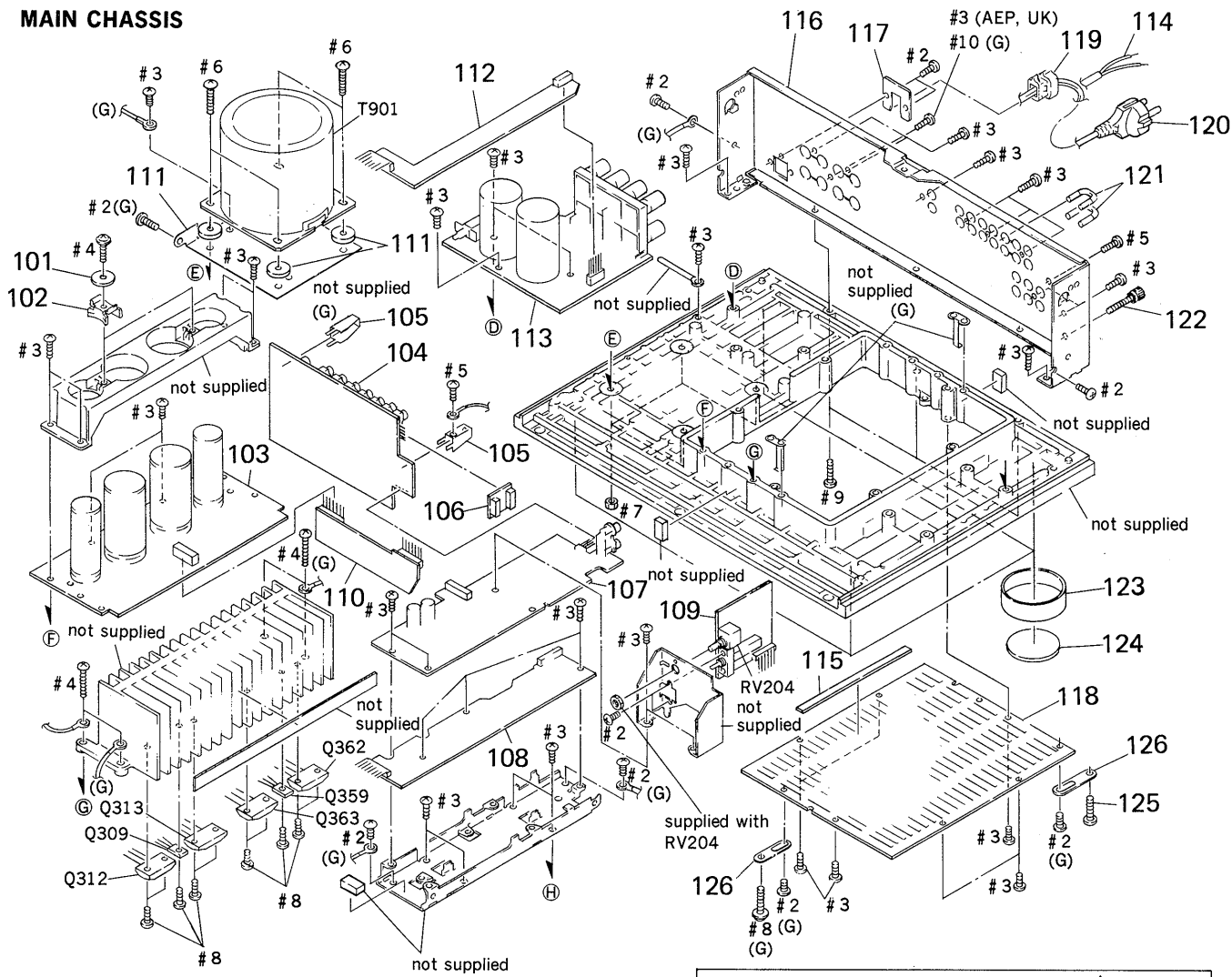

Note: The components identified by mark \triangle or dotted line with mark \triangle are critical for safety. Replace only with part number specified.

Ref. No.	Part No.	Description	Remark
101	4-945-833-11	WASHER (DIA. 14)	
102	4-946-329-01	RETAINER, ELECT CAP	
103	* A-4345-367-A	MAIN BOARD, COMPLETE (AE1, UK)	
103	* A-4345-368-A	MAIN BOARD, COMPLETE (AE2)	
103	* A-4345-666-A	MAIN BOARD, COMPLETE (G)	
104	* 1-639-372-11	INPUT BOARD	
105	* 4-946-336-01	BRACKET (GROUND)	
106	* 1-639-382-11	VR J BOARD	
107	* A-4345-370-A	EQ BOARD, COMPLETE (AEP, UK)	
107	* A-4345-371-A	EQ BOARD, COMPLETE (G)	
108	* A-4345-379-A	TONE BOARD, COMPLETE	
109	* 1-639-360-11	VR BOARD	
110	* 1-639-369-11	A/B (J) BOARD	
111	4-885-984-21	WASHER (AEP, UK)	
112	* 1-639-368-11	RELAY (J) BOARD	
113	* 1-639-367-11	SP BOARD	
114	\triangle . 1-559-272-21	CORD, POWER (UK)	
115	* 4-916-782-21	DAMPER	
116	* 4-944-612-51	PANEL, BACK (AE1, G, UK)	
116	* 4-944-612-61	PANEL, BACK (AE2)	

Ref. No.	Part No.	Description	Remark
117	* 4-923-873-01	BRACKET, CORD STOPPER	
118	* 4-916-732-01	BOARD, BOTTOM	
119	2-352-626-01	BUSHING, CORD	
120	\triangle . 1-575-953-11	CORD, POWER (AEP, G)	
121	1-535-706-11	PLUG, JUMPER	
122	* 4-941-033-01	SCREW, FIXED, FEEDER	
123	4-923-882-02	RING (LARGE-16), ORNAMENTAL, FOOT	
124	* 4-923-850-01	FOOT (DIA. 46)	
125	4-921-437-01	SCREW (M3X20), TAPPING (G)	
126	* 4-941-988-01	BRACKET (GROUND) (G)	
Q309	8-729-203-45	TRANSISTOR 2SC3423-0	
Q312	8-729-322-28	TRANSISTOR 2SC2922M-0Y	
Q313	8-729-322-29	TRANSISTOR 2SA1216M-0Y	
Q359	8-729-203-45	TRANSISTOR 2SC3423-0	
Q362	8-729-322-28	TRANSISTOR 2SC2922M-0Y	
Q363	8-729-322-29	TRANSISTOR 2SA1216M-0Y	
RV204	1-241-515-11	RES, VAR, CARBON 60K/60K (ATTENUATOR)	
T901	\triangle . 1-450-498-11	TRANSFORMER, POWER (AE1, G)	
T901	\triangle . 1-450-502-11	TRANSFORMER, POWER (AE2)	
T901	\triangle . 1-450-541-11	TRANSFORMER, POWER (UK)	

SECTION 5 ELECTRICAL PARTS LIST

EQ SP RELAY (J)

A/B (J) INPUT

NOTE:

- Due to standardization, replacements in the parts list may be different from the parts specified in the diagrams or the components used on the set.
- Items marked "*" are not stocked since they are seldom required for routine service. Some delay should be anticipated when ordering these items.
- -XX, -X mean standardized parts, so they may have some differences from the original one.
- CAPACITORS
uF: μ F

- RESISTORS
All resistors are in ohms
METAL: Metal-film resistor
METAL OXIDE: Metal Oxide-film resistor
F: nonflammable
- COILS
uH: μ H
- SEMICONDUCTORS
In each case, u: μ , for example:
uA...: μ A..., uPA...: μ PA...,
uPB...: μ PB..., uPC...: μ PC...,
uPD...: μ PD....

The components identified by mark Δ or dotted line with mark Δ are critical for safety. Replace only with part number specified.

When indicating parts by reference number, please include the board name.

- G : Germany model
- AE 2: North European model

Ref. No.	Part No.	Description	Remark	Ref. No.	Part No.	Description	Remark
	* A-4345-370-A	EQ BOARD, COMPLETE (EXCEPT G)		C319	1-130-467-00	MYLAR 470PF	5% 50V (G)
	* A-4345-371-A	EQ BOARD, COMPLETE (G)		C320	1-130-487-00	MYLAR 0.022uF	5% 50V (G)
		*****		C321	1-130-487-00	MYLAR 0.022uF	5% 50V (G)
	* 1-639-367-11	SP BOARD		C401	1-136-811-11	FILM 330PF	5% 100V
		*****				(AEP, UK)	
	* 1-639-368-11	RELAY (J) BOARD		C401	1-110-335-11	MYLAR 100PF	5% 50V (G)

	* 1-639-369-11	A/B (J) BOARD		C402	1-123-369-00	ELECT 4.7uF	20% 50V
		*****		C403	1-126-103-11	ELECT 470uF	20% 16V
	* 1-639-372-11	INPUT BOARD		C404	1-130-341-00	FILM 0.056uF	2% 100V
		*****		C405	1-130-971-00	FILM 0.016uF	2% 100V
				C406	1-124-122-11	ELECT 100uF	20% 50V
	* 1-533-213-31	HOLDER, FUSE		C407	1-130-470-00	MYLAR 820PF	5% 50V
	* 1-560-242-61	BUS BAR 2P		C408	1-126-059-11	ELECT 10uF	20% 50V
	* 4-946-336-01	BRACKET (GROUND)		C409	1-126-052-11	ELECT 100uF	20% 50V
		< CAPACITOR >		C410	1-126-052-11	ELECT 100uF	20% 50V
C102	1-162-282-31	CERAMIC 100PF	10% 50V (G)	C413	1-124-557-11	ELECT 1000uF	20% 25V
C301	1-104-278-11	POLYSTYRENE 100PF	5% 50V	C414	1-124-557-11	ELECT 1000uF	20% 25V
C302	1-123-369-00	ELECT 4.7uF	20% 50V	C415	1-162-284-31	CERAMIC 150PF	10% 50V (G)
C303	1-136-810-11	FILM 220PF	5% 100V	C420	1-161-379-00	CERAMIC 0.01uF	20% 25V (G)
C304	1-124-122-11	ELECT 100uF	20% 50V	C421	1-161-379-00	CERAMIC 0.01uF	20% 25V (G)
C305	1-124-122-11	ELECT 100uF	20% 50V	C422	1-106-367-00	MYLAR 0.01uF	5% 200V (G)
C306	1-104-272-11	POLYSTYRENE 33PF	10% 50V	C423	1-106-367-00	MYLAR 0.01uF	5% 200V (G)
		(AEP, UK)		C424	1-130-483-00	MYLAR 0.01uF	5% 50V (G)
C306	1-104-274-11	POLYSTYRENE 47PF	10% 50V (G)	C425	1-162-282-31	CERAMIC 100PF	10% 50V (G)
C307	1-124-910-11	ELECT 47uF	20% 50V	C506	1-125-695-11	ELECT 12000uF	20% 63V
C308	1-104-274-11	POLYSTYRENE 47PF	10% 50V	C507	1-125-695-11	ELECT 12000uF	20% 63V
		(AEP, UK)					
C308	1-104-278-11	POLYSTYRENE 100PF	5% 50V (G)	C601	Δ . 1-161-741-00	CERAMIC 0.001uF	10% 400V
C309	1-130-483-00	MYLAR 0.01uF	5% 50V (G)			< CONNECTOR >	
C310	1-124-922-11	ELECT 1000uF	20% 63V	CP3	1-506-906-11	PIN, CONNECTOR 5P	
C311	1-124-922-11	ELECT 1000uF	20% 63V	CP6	1-560-941-00	PIN, CONNECTOR 4P	
C317	1-104-326-11	POLYSTYRENE 7PF	1PF 125V	CP7	* 1-568-202-11	PIN, CONNECTOR (PC BOARD)	10P
C318	1-124-130-00	ELECT 100uF	20% 63V	CP8	* 1-568-202-11	PIN, CONNECTOR (PC BOARD)	10P

EQ **SP** **RELAY (J)** **A/B (J)** **INPUT**

Ref. No.	Part No.	Description	Remark
CP9	* 1-568-202-11	PIN, CONNECTOR (PC BOARD) 10P	
CP10	* 1-580-854-11	PIN, CONNECTOR (PC BOARD) 6P	
CS9	* 1-562-334-00	SOCKET, CONNECTOR 10P	
CS10	1-561-115-00	SOCKET, CONNECTOR 6P	
CS12	1-562-087-00	SOCKET, CONNECTOR 4P	
< DIODE >			
D301	8-719-933-41	DIODE HZS6C3L	
D302	8-719-912-20	DIODE 1SS120	
D303	8-719-912-20	DIODE 1SS120	
D304	8-719-912-20	DIODE 1SS120	
D305	8-719-912-20	DIODE 1SS120	
D306	8-719-912-20	DIODE 1SS120	
D351	8-719-933-41	DIODE HZS6C3L	
D352	8-719-912-20	DIODE 1SS120	
D353	8-719-912-20	DIODE 1SS120	
D354	8-719-912-20	DIODE 1SS120	
D355	8-719-912-20	DIODE 1SS120	
D356	8-719-912-20	DIODE 1SS120	
D401	8-719-000-84	DIODE UZL-7M1	
D515	8-719-912-20	DIODE 1SS120	
D516	8-719-912-20	DIODE 1SS120	
D521	8-719-912-20	DIODE 1SS120	
< CONNECTOR >			
DR6	* 1-564-338-00	PIN, CONNECTOR 4P	
EH4	* 1-564-506-11	PLUG, CONNECTOR 3P	
< IC >			
IC401	8-759-981-98	IC RC4560DD	
IC402	8-759-231-59	IC TA7815S	
IC403	8-759-245-87	IC TA7915S	
< COIL >			
L301	1-428-133-11	COIL, AIR-CORE	
L303	* 1-428-203-11	COIL, AIR-CORE	
L304	* 1-428-203-11	COIL, AIR-CORE	
L351	1-428-133-11	COIL, AIR-CORE	
L401	1-424-397-11	COIL, CHOKE 200uH (G)	
L402	1-424-397-11	COIL, CHOKE 200uH (G)	
L451	1-424-397-11	COIL, CHOKE 200uH (G)	
L452	1-424-397-11	COIL, CHOKE 200uH (G)	
< PIN JACK >			
PJ1	* 1-573-142-41	JACK, PIN 4P (TAPE1 IN/REC OUT)	
PJ2	* 1-573-142-41	JACK, PIN 4P (TAPE2 IN/REC OUT)	
PJ3	1-568-978-21	JACK 6P (TUNNER, CD, AUX)	
PJ4	1-568-978-21	JACK 6P (DIRECT INPUT, ADAPTOR IN/OUT)	
PJ5	1-573-141-11	JACK 2P (PRE OUT)	

Ref. No.	Part No.	Description	Remark
PJ6	1-580-054-11	JACK, PIN 2P (PHONO)	
< TRANSISTOR >			
Q301	8-729-620-17	TRANSISTOR 2SC2259-FG	
Q302	8-729-140-82	TRANSISTOR 2SA988-PAFAEA	
Q303	8-729-140-82	TRANSISTOR 2SA988-PAFAEA	
Q304	8-729-142-01	TRANSISTOR 2SC1941-LK	
Q305	8-729-201-56	TRANSISTOR 2SK246-GR2	
Q306	8-729-140-82	TRANSISTOR 2SA988-PAFAEA	
Q307	8-729-803-76	TRANSISTOR 2SA1371-E	
Q308	8-729-142-01	TRANSISTOR 2SC1941-LK	
Q351	8-729-620-17	TRANSISTOR 2SC2259-FG	
Q352	8-729-140-82	TRANSISTOR 2SA988-PAFAEA	
Q353	8-729-140-82	TRANSISTOR 2SA988-PAFAEA	
Q354	8-729-142-01	TRANSISTOR 2SC1941-LK	
Q355	8-729-201-56	TRANSISTOR 2SK246-GR2	
Q356	8-729-140-82	TRANSISTOR 2SA988-PAFAEA	
Q357	8-729-803-76	TRANSISTOR 2SA1371-E	
Q358	8-729-142-01	TRANSISTOR 2SC1941-LK	
Q401	8-729-354-52	TRANSISTOR 2SC2545-E	
Q402	8-729-354-52	TRANSISTOR 2SC2545-E	
Q451	8-729-354-52	TRANSISTOR 2SC2545-E	
Q452	8-729-354-52	TRANSISTOR 2SC2545-E	
< RESISTOR >			
R101	1-246-545-00	CARBON 1.0M 5% 1/4W	
R102	1-246-545-00	CARBON 1.0M 5% 1/4W	
R103	1-246-545-00	CARBON 1.0M 5% 1/4W	
R104	1-246-545-00	CARBON 1.0M 5% 1/4W	
R105	1-246-545-00	CARBON 1.0M 5% 1/4W	
R106	1-247-713-11	CARBON 1K 5% 1/4W	
R107	1-247-713-11	CARBON 1K 5% 1/4W	
R108	1-246-545-00	CARBON 1.0M 5% 1/4W	
R109	1-246-545-00	CARBON 1.0M 5% 1/4W	
R110	1-247-739-11	CARBON 100 5% 1/2W	
R301	1-247-713-11	CARBON 1K 5% 1/4W	
R302	1-249-469-11	CARBON 100K 5% 1/4W	
R303	1-247-704-11	CARBON 220 5% 1/4W	
R304	1-247-704-11	CARBON 220 5% 1/4W	
R305	1-247-704-11	CARBON 220 5% 1/4W	
R306	1-247-717-11	CARBON 2.2K 5% 1/4W	
R307	1-249-490-11	CARBON 27K 5% 1/2W	
R308	1-247-704-11	CARBON 220 5% 1/4W	
R309	1-247-721-11	CARBON 4.7K 5% 1/4W	
R310	1-249-516-11	CARBON 33 5% 1/4W	
R311	1-247-700-11	CARBON 100 5% 1/4W	
R326	1-249-721-11	CARBON 100K 5% 1/2W	
R327	1-249-668-11	CARBON 620 5% 1/2W	
R328	1-247-727-11	CARBON 10 5% 1/2W	

EQ **SP** **RELAY (J)** **A/B (J)** **INPUT**

MAIN **TR** **VR** **H. P** **TR** **MUT** **MUT LED** **POWER LED** **VR J**

Ref. No.	Part No.	Description	Remark
R330	1-247-255-00	CARBON	4.3K 5% 1/2W
R331	1-247-739-11	CARBON	100 5% 1/2W
R332	1-247-727-11	CARBON	10 5% 1/2W (G)
R333	1-247-727-11	CARBON	10 5% 1/2W (G)
R334	1-247-255-00	CARBON	4.3K 5% 1/2W
R335	1-247-700-11	CARBON	100 5% 1/4W
R405	1-247-706-11	CARBON	330 5% 1/4W (AEP, UK)
R406	1-247-700-11	CARBON	100 5% 1/4W
R407	1-249-469-11	CARBON	100K 5% 1/4W
R408	1-249-469-11	CARBON	100K 5% 1/4W
R409	1-247-710-11	CARBON	560 5% 1/4W
R410	1-247-710-11	CARBON	560 5% 1/4W
R411	1-247-725-11	CARBON	10K 5% 1/4W
R412	1-247-700-11	CARBON	100 5% 1/4W
R413	1-260-661-11	CARBON	6.8 5% 1/4W
R414	1-247-138-00	CARBON	2K 5% 1/4W
R415	1-247-700-11	CARBON	100 5% 1/4W (AEP, UK)
R415	1-249-542-11	CARBON	390 5% 1/4W (G)
R416	1-246-545-00	CARBON	1.0M 5% 1/4W
R417	1-249-844-11	CARBON	56K 1% 1/2W
R418	1-249-818-11	CARBON	4.7K 1% 1/2W
R419	1-247-713-11	CARBON	1K 5% 1/4W
R420	1-249-421-11	CARBON	2.2K 5% 1/4W (G)
R421	1-249-421-11	CARBON	2.2K 5% 1/4W (G)
R422	1-247-714-11	CARBON	1.2K 5% 1/4W
R423	1-247-714-11	CARBON	1.2K 5% 1/4W
R424	1-247-714-11	CARBON	1.2K 5% 1/4W
R425	1-247-714-11	CARBON	1.2K 5% 1/4W
R426	1-247-714-11	CARBON	1.2K 5% 1/4W
R427	1-247-714-11	CARBON	1.2K 5% 1/4W
R428	1-247-714-11	CARBON	1.2K 5% 1/4W
R429	1-247-714-11	CARBON	1.2K 5% 1/4W
R430	1-247-249-00	CARBON	2.4K 5% 1/2W
R431	1-247-249-00	CARBON	2.4K 5% 1/2W
< RELAY >			
RY502	1-515-727-11	RELAY	
RY503	1-515-501-00	RELAY	
RY504	1-515-501-00	RELAY	
< SWITCH >			
S101	1-571-115-11	SWITCH, SLIDE (INPUT SELECTOR)	
S102	1-571-115-11	SWITCH, SLIDE (REC OUT SELECTOR)	
S401	1-571-111-11	SWITCH, PUSH (1 KEY) (CARTRIDGE)	
S601	△. 1-554-920-11	SWITCH, PUSH (AC POWER) (1 KEY) (POWER)	
< CONNECTOR >			
SE1	1-564-320-00	PIN, CONNECTOR 2P	
SE2	1-564-320-00	PIN, CONNECTOR 2P	

Ref. No.	Part No.	Description	Remark
< TERMINAL >			
TM301	1-537-235-11	TERMINAL BOARD (SP) (SPEAKER) (AE1, UK)	
TM301	1-537-227-11	TERMINAL BOARD (SP) (SPEAKER) (AE2)	
TM301	1-537-228-11	TERMINAL BOARD (SP) (SPEAKER) (G)	
< CONNECTOR >			
VH9	* 1-564-321-00	PIN, CONNECTOR 2P	
VH10	* 1-564-321-21	PIN, CONNECTOR 2P	
VH12	* 1-564-241-00	PIN, CONNECTOR 4P	

* A-4345-367-A MAIN BOARD, COMPLETE (AE1, UK)			
* A-4345-368-A MAIN BOARD, COMPLETE (AE2)			
* A-4345-666-A MAIN BOARD, COMPLETE (G)			

* A-4345-379-A TONE BOARD, COMPLETE			

* 1-639-360-11 VR BOARD			

* 1-639-361-11 H. P BOARD			

* 1-639-362-11 TONE (J) BOARD			

* 1-639-363-11 MUT BOARD			

* 1-639-364-11 MUT LED BOARD			

* 1-639-365-11 POWER LED BOARD			

* 1-639-382-11 VR J BOARD			

* 4-942-408-01 SPACER (DIA. 30)			
< CAPACITOR >			
C201	1-106-363-00	MYLAR	6800PF 5% 200V
C202	1-130-489-00	MYLAR	0.033uF 5% 50V
C203	1-130-491-00	MYLAR	0.047uF 5% 50V
C204	1-136-171-00	FILM	0.33uF 5% 50V
C206	1-136-172-00	FILM	0.39uF 5% 50V
C312	1-126-051-11	ELECT	47uF 20% 50V
C313	1-107-159-00	MICA	33PF 5% 500V
C314	1-107-159-00	MICA	33PF 5% 500V
C315	1-130-487-00	MYLAR	0.022uF 5% 50V
(AE1, G, UK)			
C315	1-130-491-00	MYLAR	0.047uF 5% 50V
(AE2)			
C316	1-130-491-00	MYLAR	0.047uF 5% 50V
(AE2)			
C322	1-162-282-31	CERAMIC	100PF 10% 50V
(G)			

Note: The components identified by mark △ or dotted line with mark △ are critical for safety. Replace only with part number specified.

MAIN

tone

VR

H. P

tone (J)

MUT

MUT LED

POWER LED

VR J

Ref. No.	Part No.	Description	Remark
C501	1-125-695-11	ELECT	12000uF 20% 63V
C502	1-125-695-11	ELECT	12000uF 20% 63V
C503	1-125-694-11	ELECT	5600uF 20% 63V
C504	1-125-694-11	ELECT	5600uF 20% 63V
C508	1-136-880-11	FILM	2. 2uF 10% 160V
C509	1-126-069-11	ELECT	1uF 20% 100V
C510	1-126-066-11	ELECT	470uF 20% 63V
C511	1-126-062-11	ELECT	47uF 20% 63V
C512	1-126-219-11	ELECT	3. 3uF 20% 63V
C513	1-126-163-11	ELECT	4. 7uF 20% 50V
C517	1-126-023-11	ELECT	100uF 20% 25V
C518	1-130-487-00	MYLAR	0. 022uF 5% 50V
C519	1-126-023-11	ELECT	100uF 20% 25V
C520	1-130-471-00	MYLAR	0. 001uF 5% 50V
C521	1-130-483-00	MYLAR	0. 01uF 5% 50V
C522	1-130-483-00	MYLAR	0. 01uF 5% 50V
< CONNECTOR >			
CP1	* 1-568-202-11	PIN, CONNECTOR (PC BOARD)	10P
CP2	* 1-560-552-00	PIN, CONNECTOR	5P
CP4	* 1-568-202-11	PIN, CONNECTOR (PC BOARD)	10P
CP5	1-568-577-11	PIN, CONNECTOR (PC BOARD)	3P
CP11	* 1-560-531-00	PIN, CONNECTOR	5P
CS1	* 1-562-334-00	SOCKET, CONNECTOR	10P
CS2	* 1-562-334-00	SOCKET, CONNECTOR	10P
CS4	* 1-562-334-00	SOCKET, CONNECTOR	10P
CS6	* 1-563-106-11	CONNECTOR (SOCKET)	10P
CS7	* 1-565-835-11	SOCKET, CONNECTOR	3P
< DIODE >			
D307	8-719-912-20	DIODE	1SS120
D308	8-719-912-20	DIODE	1SS120
D309	8-719-912-20	DIODE	1SS120
D357	8-719-912-20	DIODE	1SS120
D358	8-719-912-20	DIODE	1SS120
D359	8-719-912-20	DIODE	1SS120
D501	8-719-230-02	DIODE	30DF2
D502	8-719-230-02	DIODE	30DF2
D503	8-719-230-02	DIODE	30DF2
D504	8-719-230-02	DIODE	30DF2
D505	8-719-200-82	DIODE	11ES2
D506	8-719-200-82	DIODE	11ES2
D507	8-719-200-82	DIODE	11ES2
D508	8-719-200-82	DIODE	11ES2
D509	8-719-200-82	DIODE	11ES2
D510	8-719-200-82	DIODE	11ES2
D511	8-719-200-82	DIODE	11ES2
D512	8-719-313-40	DIODE	SEL1516W
D513	8-719-912-20	DIODE	1SS120

Ref. No.	Part No.	Description	Remark
D514	8-719-912-20	DIODE	1SS120
D517	8-719-912-20	DIODE	1SS120
D518	8-719-301-49	DIODE	SEL2810A
D519	8-719-301-49	DIODE	SEL2810A
D520	8-719-912-20	DIODE	1SS120
< CONNECTOR >			
DR4	* 1-564-339-61	PIN, CONNECTOR	5P
DR5	* 1-564-337-00	PIN, CONNECTOR	3P
EH1	* 1-564-506-11	PLUG, CONNECTOR	3P
< IC >			
IC501	8-759-111-68	IC	uPC1237HA
< JACK >			
J301	1-507-796-71	JACK (HEADPHONES)	
< TRANSISTOR >			
Q309	8-729-203-45	TRANSISTOR	2SC3423-0
Q310	8-729-107-53	TRANSISTOR	2SC2275A-QP
Q311	8-729-141-10	TRANSISTOR	2SA985A-QP
Q312	8-729-322-28	TRANSISTOR	2SC2922M-0Y
Q313	8-729-322-29	TRANSISTOR	2SA1216M-0Y
Q314	8-729-140-82	TRANSISTOR	2SA988-PAFAEA
Q359	8-729-203-45	TRANSISTOR	2SC3423-0
Q360	8-729-107-53	TRANSISTOR	2SC2275A-QP
Q361	8-729-141-10	TRANSISTOR	2SA985A-QP
Q362	8-729-322-28	TRANSISTOR	2SC2922M-0Y
Q363	8-729-322-29	TRANSISTOR	2SA1216M-0Y
Q364	8-729-140-82	TRANSISTOR	2SA988-PAFAEA
Q501	8-729-194-57	TRANSISTOR	2SC945-P
Q502	8-729-141-03	TRANSISTOR	2SA733-QP
Q503	8-729-141-03	TRANSISTOR	2SA733-QP
Q504	8-729-140-96	TRANSISTOR	2SD774-34
Q505	8-729-620-05	TRANSISTOR	2SC2603-EF
Q506	8-729-620-05	TRANSISTOR	2SC2603-EF
< RESISTOR >			
R111	1-259-580-11	CARBON	11K 5% 1/2W
R201	1-247-721-11	CARBON	4. 7K 5% 1/4W
R202	1-247-712-11	CARBON	820 5% 1/4W
R203	1-246-545-00	CARBON	1. 0M 5% 1/4W
R204	1-247-716-11	CARBON	1. 8K 5% 1/4W
R205	1-259-502-11	CARBON	4. 7M 5% 1/4W
R206	1-259-502-11	CARBON	4. 7M 5% 1/4W
R207	1-247-128-00	CARBON	750 5% 1/4W
R208	1-249-577-11	CARBON	11K 5% 1/4W
R209	1-247-138-00	CARBON	2K 5% 1/4W

MAIN **TR** **VR** **H. P** **TONE (J)** **MUT** **MUT LED** **POWER LED** **VR J**

Ref. No.	Part No.	Description	Remark
R210	1-247-152-00	CARBON 8.2K 5%	1/4W
R211	1-259-580-11	CARBON 11K 5%	1/2W
R314	△. 1-247-713-11	CARBON 1K 5%	1/4W F
R315	1-247-707-11	CARBON 390 5%	1/4W
R316	△. 1-212-990-00	FUSIBLE 220 5%	1/2W F
R317	△. 1-212-950-00	FUSIBLE 4.7 5%	1/2W F
R318	△. 1-212-950-00	FUSIBLE 4.7 5%	1/2W F
R319	1-217-151-00	RES. METAL PLATE 0.22	
R320	1-217-151-00	RES. METAL PLATE 0.22	
R321	△. 1-247-721-11	CARBON 4.7K 5%	1/4W F
R322	1-249-460-11	CARBON 15K 5%	1/4W
R323	△. 1-212-962-00	FUSIBLE 15 5%	1/2W F
R324	△. 1-212-962-00	FUSIBLE 15 5%	1/2W F
R325	1-247-891-00	CARBON 330K 5%	1/4W
R329	1-247-747-11	CARBON 470 5%	1/2W
R501	△. 1-212-849-00	FUSIBLE 4.7 5%	1/4W F
R502	1-247-721-11	CARBON 4.7K 5%	1/4W
R503	1-247-251-00	CARBON 3K 5%	1/2W
R504	1-247-251-00	CARBON 3K 5%	1/2W
R505	1-247-251-00	CARBON 3K 5%	1/2W
R506	1-247-251-00	CARBON 3K 5%	1/2W
R507	1-247-251-00	CARBON 3K 5%	1/2W
R508	1-247-251-00	CARBON 3K 5%	1/2W
R509	1-247-251-00	CARBON 3K 5%	1/2W
R510	1-247-725-11	CARBON 10K 5%	1/4W
R511	1-249-462-11	CARBON 22K 5%	1/4W
R512	1-249-465-11	CARBON 47K 5%	1/4W
R513	1-249-465-11	CARBON 47K 5%	1/4W
R515	1-247-706-11	CARBON 330 5%	1/4W
R516	1-247-706-11	CARBON 330 5%	1/4W
R517	1-247-249-00	CARBON 2.4K 5%	1/2W
R518	1-247-249-00	CARBON 2.4K 5%	1/2W
R519	1-247-092-00	CARBON 24 5%	1/4W
R520	1-247-721-11	CARBON 4.7K 5%	1/4W
R521	1-249-461-11	CARBON 18K 5%	1/4W
R522	1-247-881-00	CARBON 120K 5%	1/4W
R523	1-247-725-11	CARBON 10K 5%	1/4W
R524	1-247-887-00	CARBON 220K 5%	1/4W
R525	1-247-757-11	CARBON 2.7K 5%	1/2W
R526	1-247-757-11	CARBON 2.7K 5%	1/2W
R527	1-249-462-11	CARBON 22K 5%	1/4W
R529	1-247-738-11	CARBON 82 5%	1/2W
R530	1-247-717-11	CARBON 2.2K 5%	1/4W
R531	1-247-251-00	CARBON 3K 5%	1/2W
R540	1-247-721-11	CARBON 4.7K 5%	1/4W
R541	1-247-721-11	CARBON 4.7K 5%	1/4W
R542	1-247-758-11	CARBON 3.3K 5%	1/2W (AE1, G, UK)
R542	1-247-251-00	CARBON 3K 5%	1/2W (AE2)
R543	1-247-758-11	CARBON 3.3K 5%	1/2W (AE1, G, UK)

Ref. No.	Part No.	Description	Remark
R543	1-247-251-00	CARBON 3K 5%	1/2W (AE2)
< VARIABLE RESISTOR >			
RT301	1-237-455-11	RES. ADJ. CARBON 500	
RT351	1-237-455-11	RES. ADJ. CARBON 500	
RV201	1-241-517-11	RES. VAR. CARBON 250K/250K (BALANCE)	
RV202	1-241-518-11	RES. VAR. CARBON 25K/100K (TREBLE)	
RV203	1-241-519-11	RES. VAR. CARBON 25K/250K (BASS)	
RV204	1-241-515-11	RES. VAR. CARBON 60K/60K (ATTENUATOR)	
< RELAY >			
RY501	1-515-727-11	RELAY	
RY505	1-515-787-11	RELAY	
< SWITCH >			
S201	1-572-738-11	SWITCH. PUSH (3 KEY) (SUBSONIC)	
S202	1-572-741-11	SWITCH. PUSH (1 KEY) (SOURCE DIRECT)	
S203	1-572-738-11	SWITCH. PUSH (3 KEY) (MODE)	
S204	1-572-738-11	SWITCH. PUSH (3 KEY) (DIRECT INPUT)	
S205	1-572-740-11	SWITCH. PUSH (1 KEY) (MUTING -20dB)	
S206	1-572-739-11	SWITCH. PUSH (2 KEY) (SPEAKER A)	
S207	1-572-739-11	SWITCH. PUSH (2 KEY) (SPEAKER B)	
S208	1-572-143-11	SWITCH. SLIDE (SOURCE DIRECT)	
< CONNECTOR >			
VH1	* 1-564-241-00	PIN, CONNECTOR 4P	
VH2	1-564-320-00	PIN, CONNECTOR 2P	
VH5	* 1-564-241-00	PIN, CONNECTOR 4P	
VH6	* 1-564-241-00	PIN, CONNECTOR 4P	

MISCELLANEOUS			

70	1-572-742-11	SWITCH, ROTARY	
71	1-572-743-11	SWITCH, ROTARY	
114	△. 1-559-272-21	CORD, POWER (UK)	
120	△. 1-575-953-11	CORD, POWER (AEP, G)	
121	1-535-706-11	PLUG, JUMPER	
T901	△. 1-450-498-11	TRANSFORMER, POWER (AE1, G)	
T901	△. 1-450-502-11	TRANSFORMER, POWER (AE2)	
T901	△. 1-450-541-11	TRANSFORMER, POWER (UK)	

Note: The components identified by mark △ or dotted line with mark △ are critical for safety. Replace only with part number specified.

Ref. No.	Part No.	Description	Remark
ACCESSORY & PACKING MATERIAL			

	3-753-600-11	MANUAL, INSTRUCTION (AE1, UK) (ENGLISH, FRENCH, SPANISH, PORTUGUESE)	
	3-753-600-41	MANUAL, INSTRUCTION (AEP, G) (GERMAN, DUTCH, SWEDISH, ITALIAN)	
*	4-929-219-01	CUSHION	
*	4-945-287-01	INDIVIDUAL CARTON	

HARDWARE LIST

#1	7-685-234-19	SCREW +KTP 2.6X8 TYPE2NON-SLIT	
#2	7-682-547-09	SCREW +BVTT 3X6 (S)	
#3	7-685-647-79	SCREW +BVTP 3X10 TYPE2 N-S	
#4	7-685-650-79	SCREW +BVTP 3X16 TYPE2 SLIT	
#5	7-682-548-09	SCREW (3X8)	
#6	7-682-565-09	SCREW +B 4X16 (G)	
#6	7-682-566-09	SCREW +B 4X20 (AEP, UK)	
#7	7-684-024-04	N 4, TYPE 2	
#8	7-685-648-79	SCREW +BVTP 3X12 TYPE2 IT-3	
#9	7-685-876-09	SCREW +BVTT 3X16 (S)	
#10	7-621-849-00	SCREW, TAPPING (G)	