

# TAN-8550

USA Model

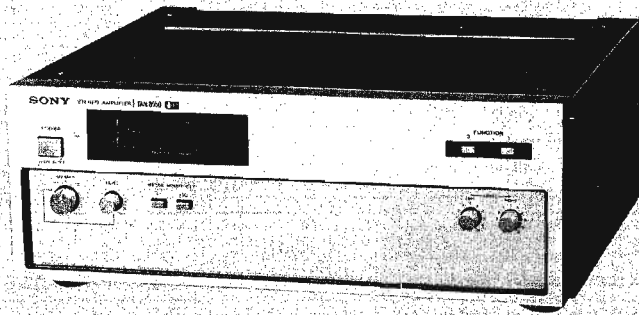

## STEREO POWER AMPLIFIER

### SPECIFICATIONS

#### GENERAL

System:	Phase-linear dc stereo amplifier in direct-coupling V-FET pure-complementary symmetry circuit
Power requirements:	120 V ac, 60 Hz
Power consumption:	260 W
AC outlet:	1 unswitched, 200 W
Dimensions:	440 (w) x 170 (h) x 410 (d) mm 17 <sup>3</sup> / <sub>8</sub> (w) x 6 <sup>3</sup> / <sub>4</sub> (h) x 16 <sup>1</sup> / <sub>8</sub> (d) inches
Weight:	19 kg (41 lb 14 oz), net 23 kg (50 lb 11 oz), in shipping carton

Power bandwidth: (IHF)	5 Hz ~ 50 kHz
Harmonic distortion:	0.1 % at rated output 0.05 % at 1 W output
IM distortion: (60 Hz : 7 kHz = 4 : 1)	0.1 % at rated output 0.05 % at 1 W output
Damping factor:	200 (8 $\Omega$ , at 1 kHz, at SPEAKER DIRECT terminal)
Residual noise:	0.01 $\mu$ W

Frequency response: 20 Hz ~ 100 kHz  $\pm$  0 dB (NORMAL)  
DC ~ 100 kHz  $\pm$  0 dB (TEST)

Inputs: Sensitivity 1.0 V RMS (for rated output)  
Impedance: 50 k $\Omega$

#### POWER AMPLIFIER SECTION

Continuous RMS power output: (rated output) (less than 0.1 % THD)	110 W + 110 W/8 $\Omega$ 110 W + 110 W/4 $\Omega$ at 1 kHz, both channels driven simultaneously
	100 W + 100 W/8 $\Omega$ at 20 Hz ~ 20 kHz, both channels driven simultaneously

#### OPTICAL PEAK PROGRAM METER

Frequency response: 30 Hz ~ 30 kHz  $\pm$  0/3 dB

Measuring range: 1 ~ 200 W  
(METER SENSITIVITY set to "1")  
0.1 ~ 20 W  
(METER SENSITIVITY set to "1/10")

**SONY**<sup>®</sup>  
**SERVICE MANUAL**

## SERVICING NOTES

1. Apply the rated ac line voltage to the set directly. Do not increase the voltage gradually by using a variable transformer or other such instrument: this will cause a V-FET failure.

### 2. V-FET Replacement

TAN-8550 uses six V-FETs (2SK60...3 pcs, 2SJ18...3 pcs) in each channel of its power amplifier. Both 2SK60 and 2SJ18 are divided into six ranks according to their  $V_{sg0}$  (gate-source voltage) and  $V_p$  (cut-off voltage). The bias resistors of the V-FET differ from a rank to a rank, and it is necessary to use the same rank of V-FETs in the same channel.

If you cannot obtain the same rank of V-FET as the one used in the repairing set, replace all six V-FETs. At the same time, replace the bias resistors according to the table given at right.

Rank of 2SK60 2SJ18	Bias Resistors	
	R725, R775	R731, R781 R732, R782
53	33 k $\Omega$	1.8 k $\Omega$
54	33 k $\Omega$	1.5 k $\Omega$
55	33 k $\Omega$	1.2 k $\Omega$
56	30 k $\Omega$	1.0 k $\Omega$
57	30 k $\Omega$	1.0 k $\Omega$
58	30 k $\Omega$	820 $\Omega$

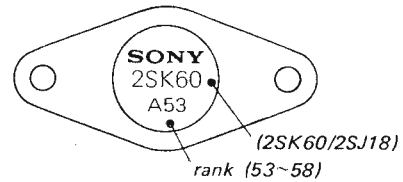

3. After the replacement of V-FET, carry out the following check to avoid further occurrence of V-FET failure.

- 1) Turn off the power of TAN-8550.
- 2) Remove the heat sink duct.
- 3) Disconnect the brown and the violet lead wires from the pins on the CLASS B POWER AMP BOARD. See the figure at bottom right.
- 4) Turn on the power and check the voltage across R737 (L-CH)/R787 (R-CH). If the reading does not agree with the value given in the table at right, try adjusting RT701 (L-CH)/RT751 (R-CH).
- 5) If adjusting RT701/RT751 still does not give correct reading, check Q713 ~ Q716 (L-CH)/Q763 ~ Q766 (R-CH). Failure of these transistors will cause V-FET failure.
- 6) After the check, turn off the power of the set and put back the two lead wires mentioned in step 3.

Rank of 2SK60 2SJ18 used in the set	Voltage drop across R737 (L-CH) R787 (R-CH)
53	18.8 ~ 23.8 V
54	23.8 ~ 28.8 V
55	28.8 ~ 33.8 V
56	33.8 ~ 38.8 V
57	38.8 ~ 43.8 V
58	43.8 ~ 48.8 V

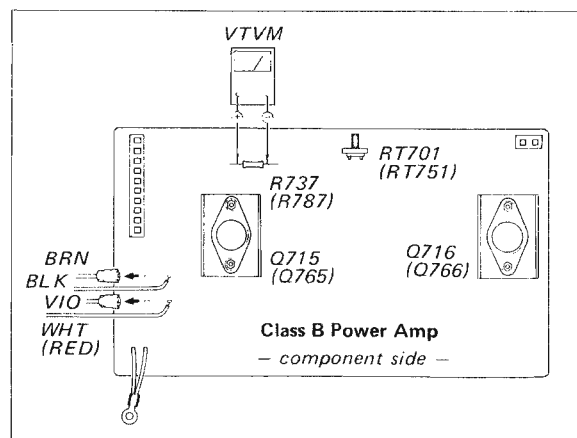
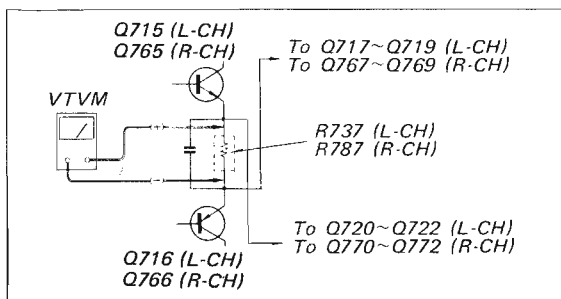

SECTION 1  
BLOCK DIAGRAM

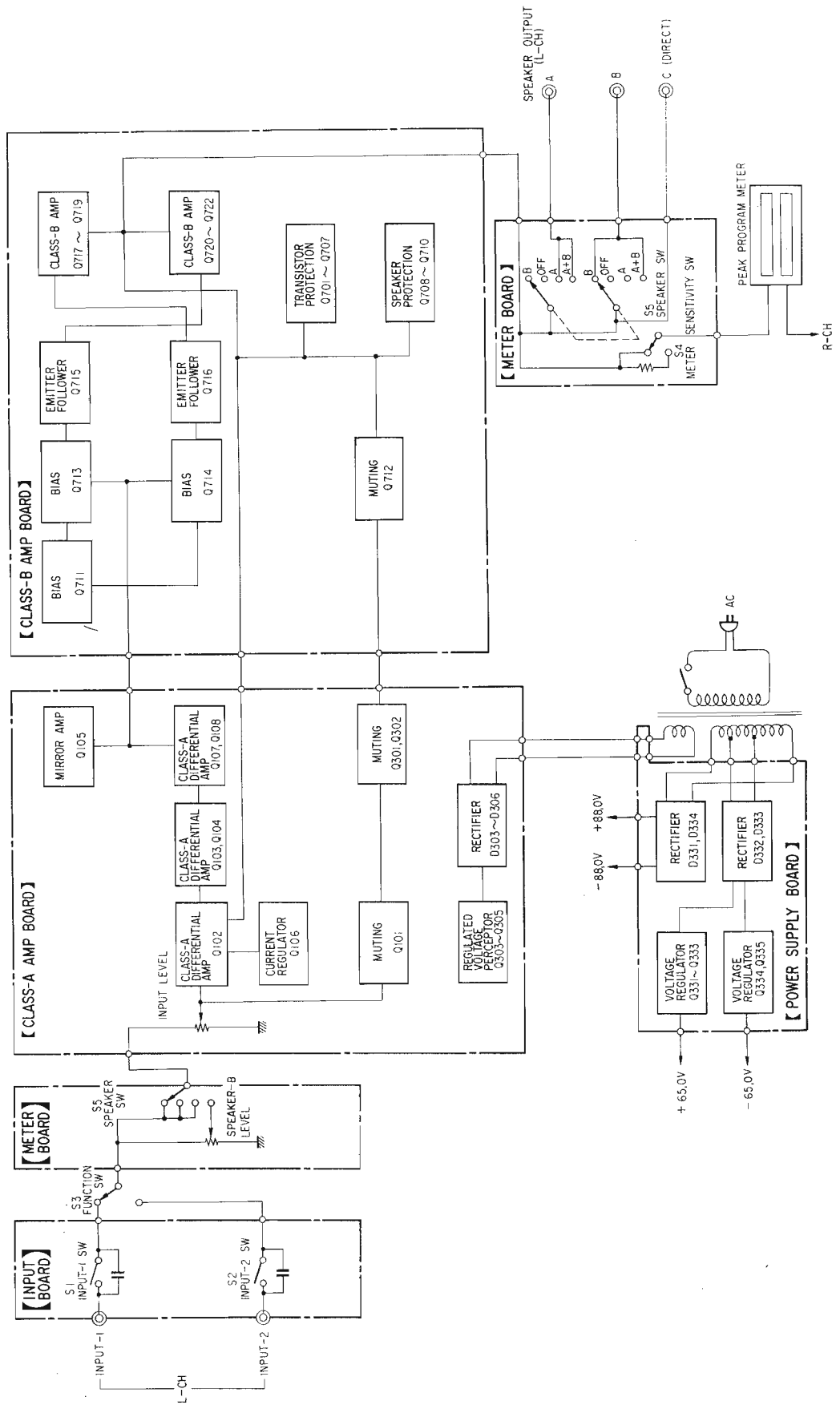

**SECTION 2  
DISASSEMBLY AND REPLACEMENT**

**2-1. PANELS REMOVAL**

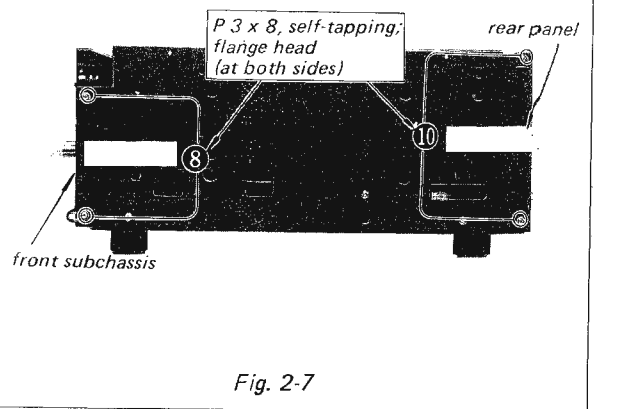
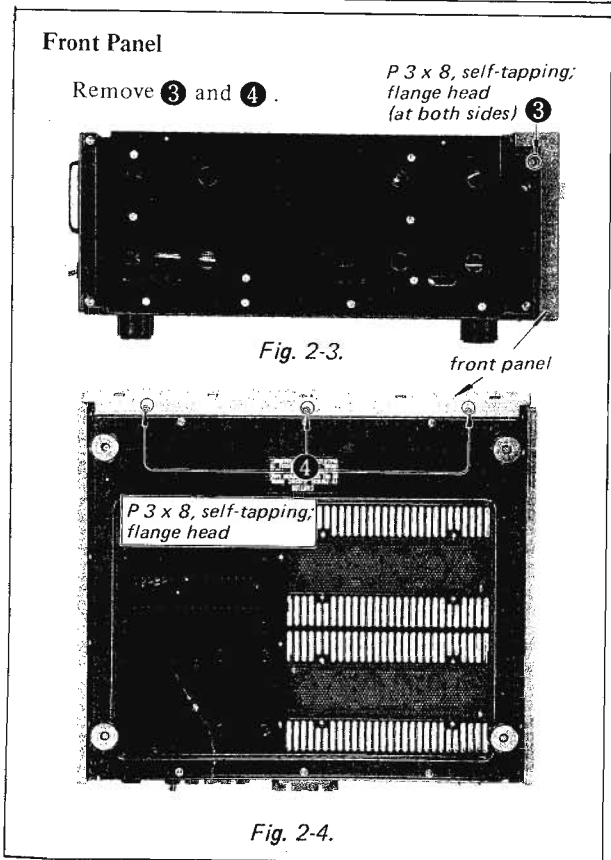
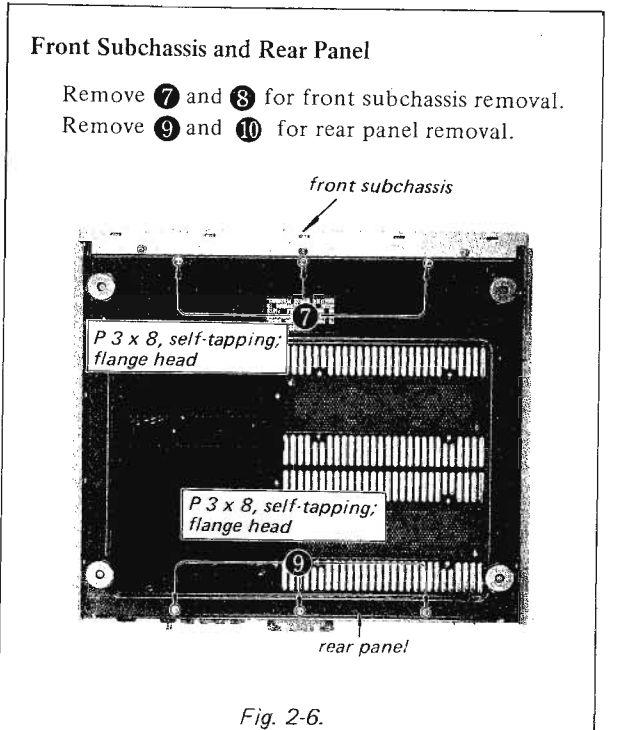
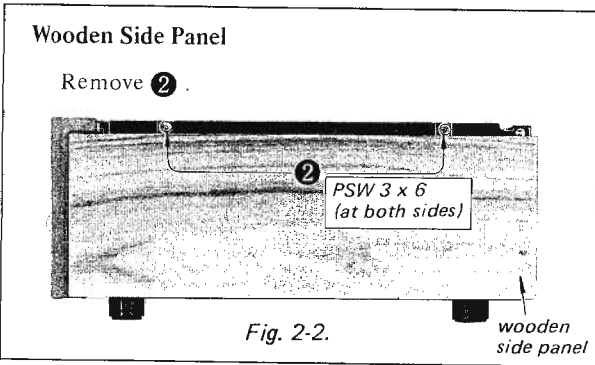
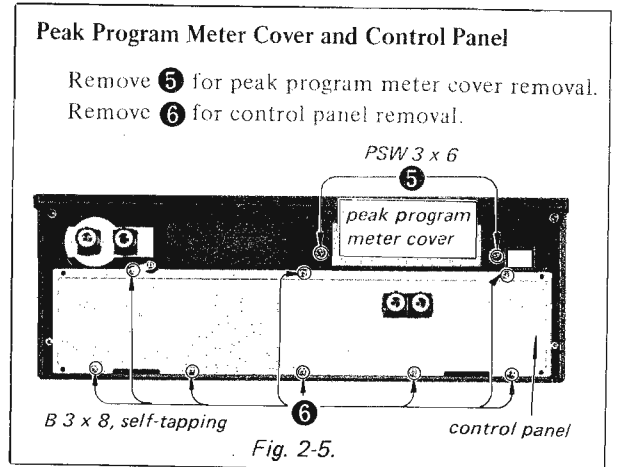
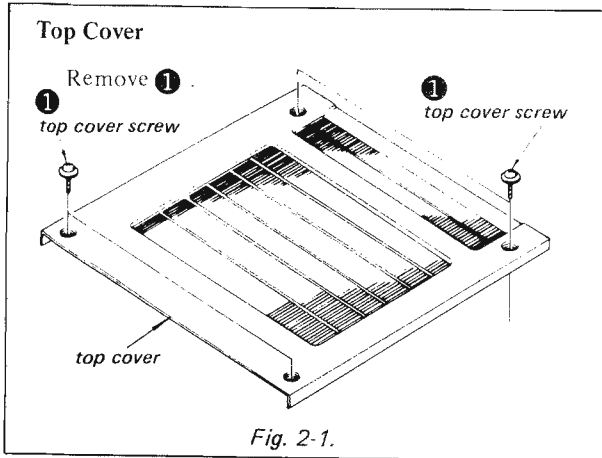

## 2-2. CIRCUIT BOARD REMOVAL AND V-FET REPLACEMENT

**Note:** Be careful with the position and the direction of the connectors when re-installing them to the circuit boards. See Fig. 2-8.

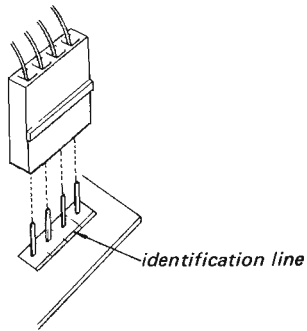

Fig. 2-8.

### Class-A Amp Board and Meter Board

Remove 11, 12 for meter board removal.  
Remove 13 for class-A amp board removal.

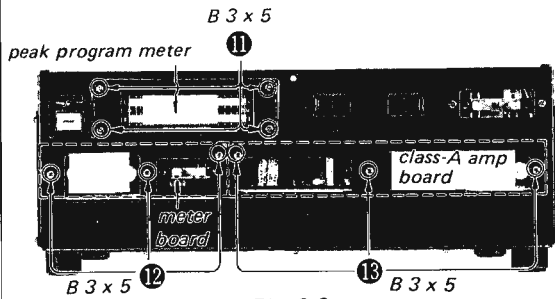

Fig. 2-9.

### Input Board

Remove 14 and 15

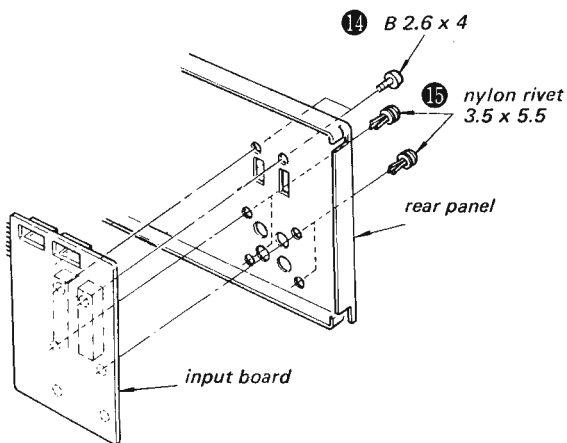

Fig. 2-10.

### Class-B Amp Board

Take out the heat sink duct by removing 16.

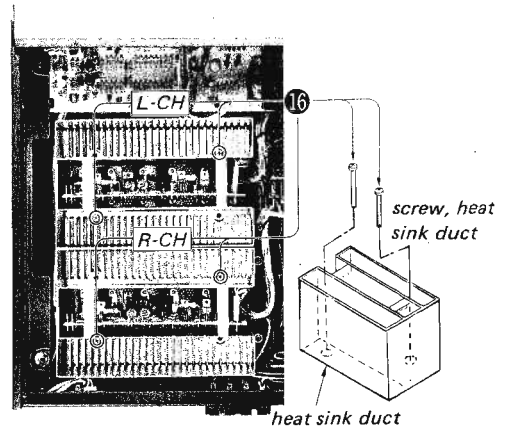

Fig. 2-11.

Remove 17 and take out the class-B amp board along with the heat sink.

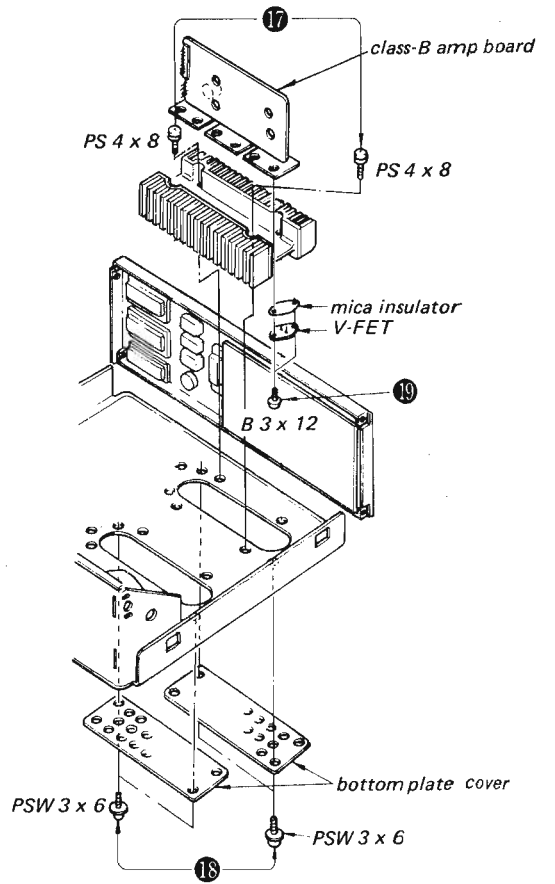

Fig. 2-12.

### V-FET Replacement

Remove 18 and 19.

**Note:** When replacing V-FET, refer to page 2.

**SECTION 3  
ADJUSTMENTS**

**Note:** Allow about five minutes for warm-up.

**3-1. LAMP VOLTAGE ADJUSTMENT**

Class-A Amp Board

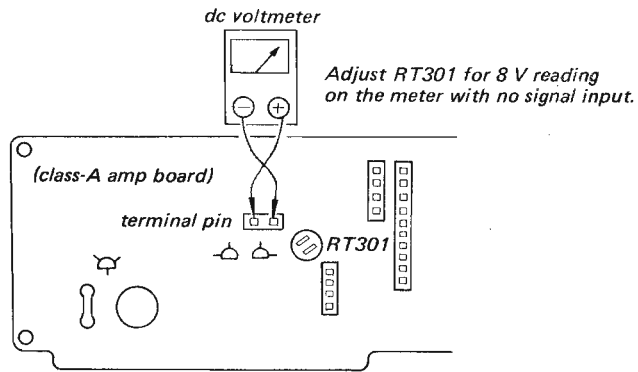

Fig. 3-1.

**3-2. DC BALANCE AND BIAS ADJUSTMENT**

**Note:** 1. Apply the rated ac line voltage to the set directly. Do not increase the voltage gradually by using a variable transformer or other such instruments: this will cause a V-FET failure.

2. Alternately repeat the two adjustments two or three times.

**DC Bias Adjustment**

Adjust RT701 (L-CH) and RT751 (R-CH) for 125 mV dc with no signal input.

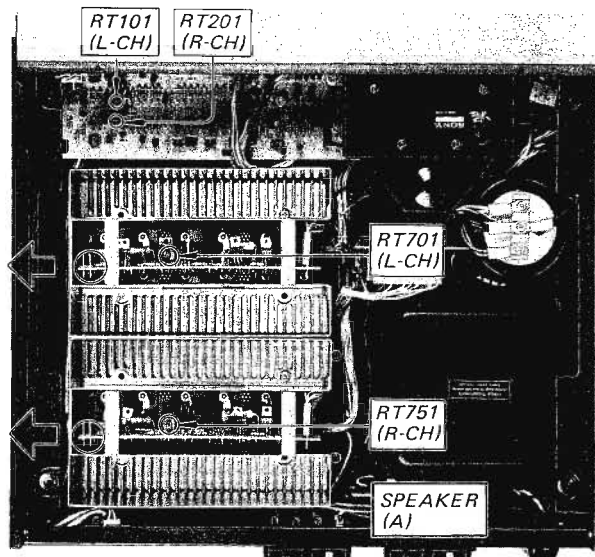
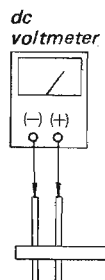

**DC Balance Adjustment**

Adjust RT101 (L-CH) and RT201 (R-CH) for 0 V dc with no signal input.

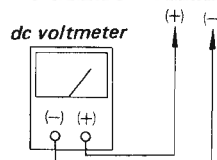

Fig. 3-2.

3-3. PEAK PROGRAM METER ADJUSTMENT AND CHECK

Test Setup:

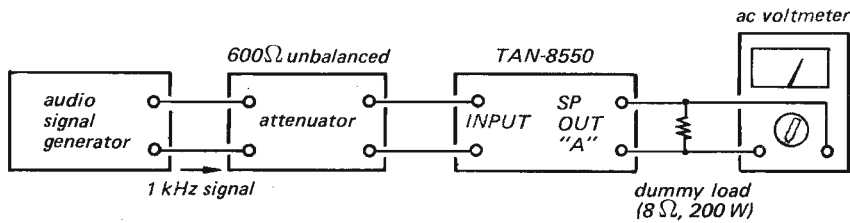

Fig. 3-3.

Procedure:

1. Adjust the attenuator for 28.3 V (100 W) reading on the ac voltmeter.
2. Set the METER SENSITIVITY switch to "x1", and adjust RT181 (L-CH) and RT281 (R-CH) (See Fig. 3-4) for 100 W reading on the peak program meter.
3. Check the following items:

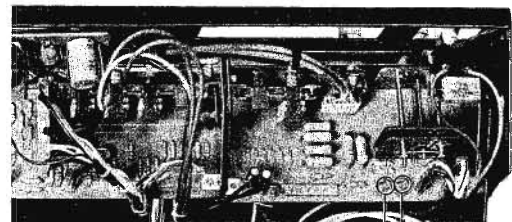
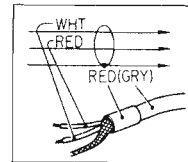
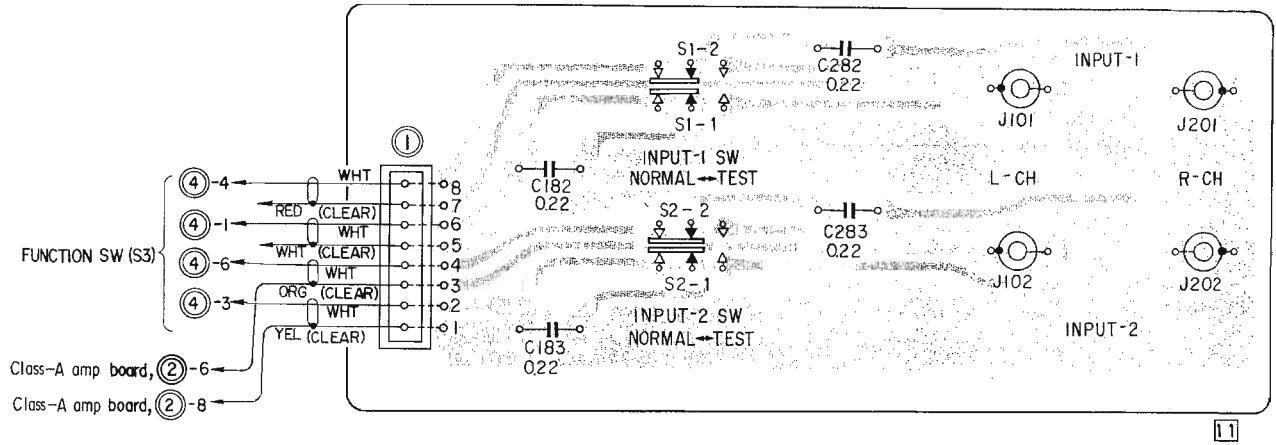

Fig. 3-4. RT181 (L-CH) RT281 (R-CH)

Step	Attenuator Setting	METER SENSITIVITY Switch Setting	PEAK PROGRAM METER Indication
3-1	Decrease 10 dB from step 2.	x1	10 W
3-2	Same as step 3-1	x1/10	100 W
3-3	Decrease 10 dB from step 3-2.	x1/10	10 W
3-4	Same as step 3-3	x1	1 W

**SECTION 4  
DIAGRAMS**

**4-1. MOUNTING DIAGRAM – Input Board –  
– Conductor Side –**





# TAN-8550 TAN-8550

## 4-2. MOUNTING DIAGRAM -- Power Supply Board -- -- Conductor Side --

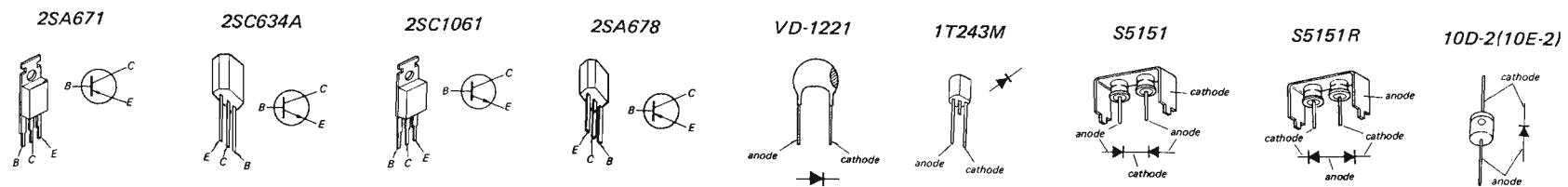
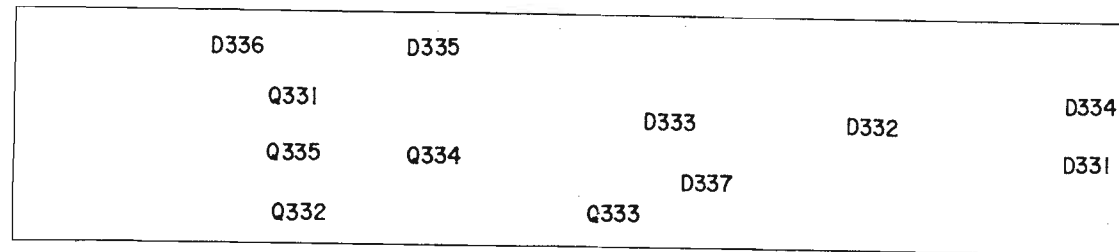
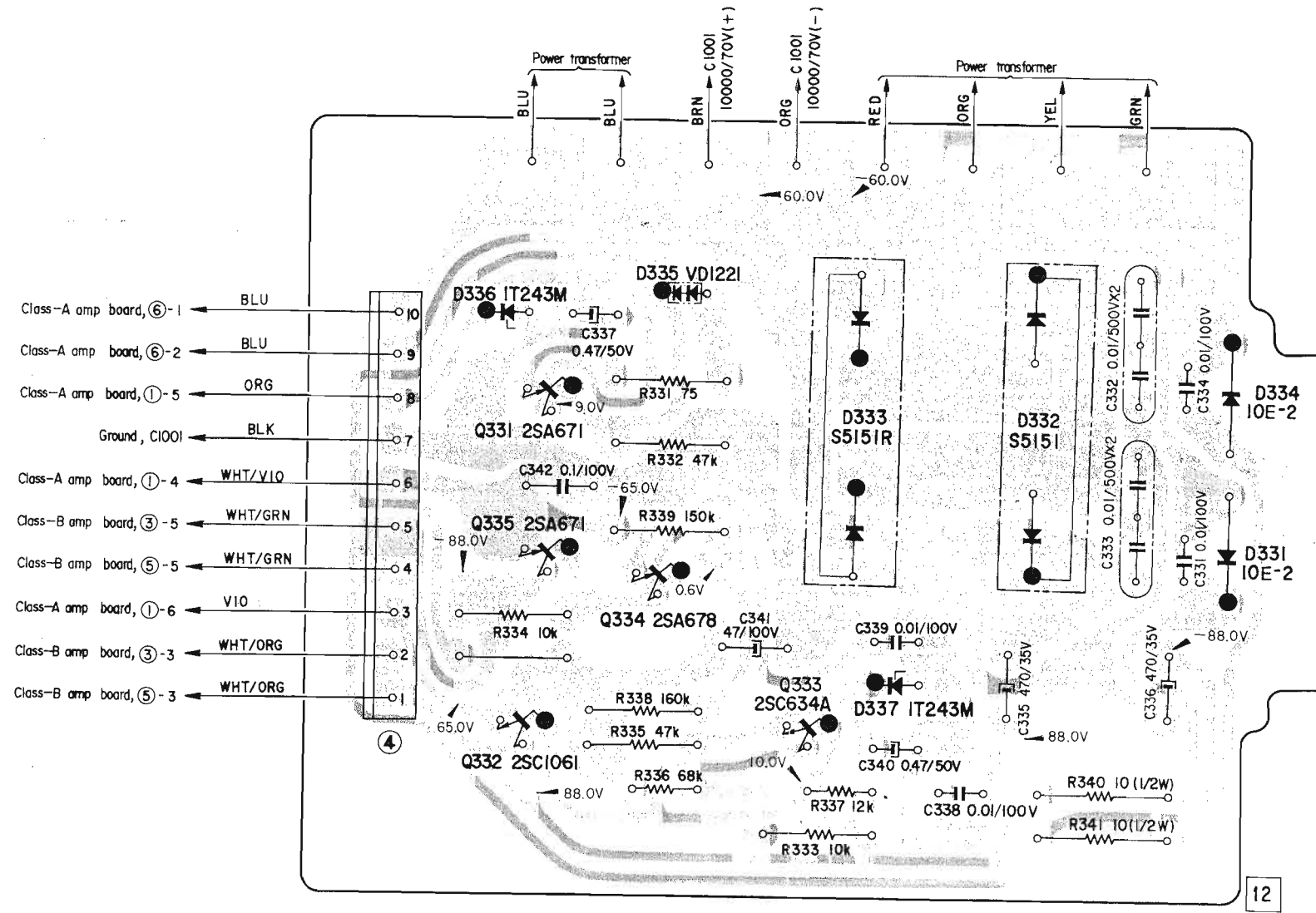

4-3. MOUNTING DIAGRAM – Meter Board –  
– Conductor Side –

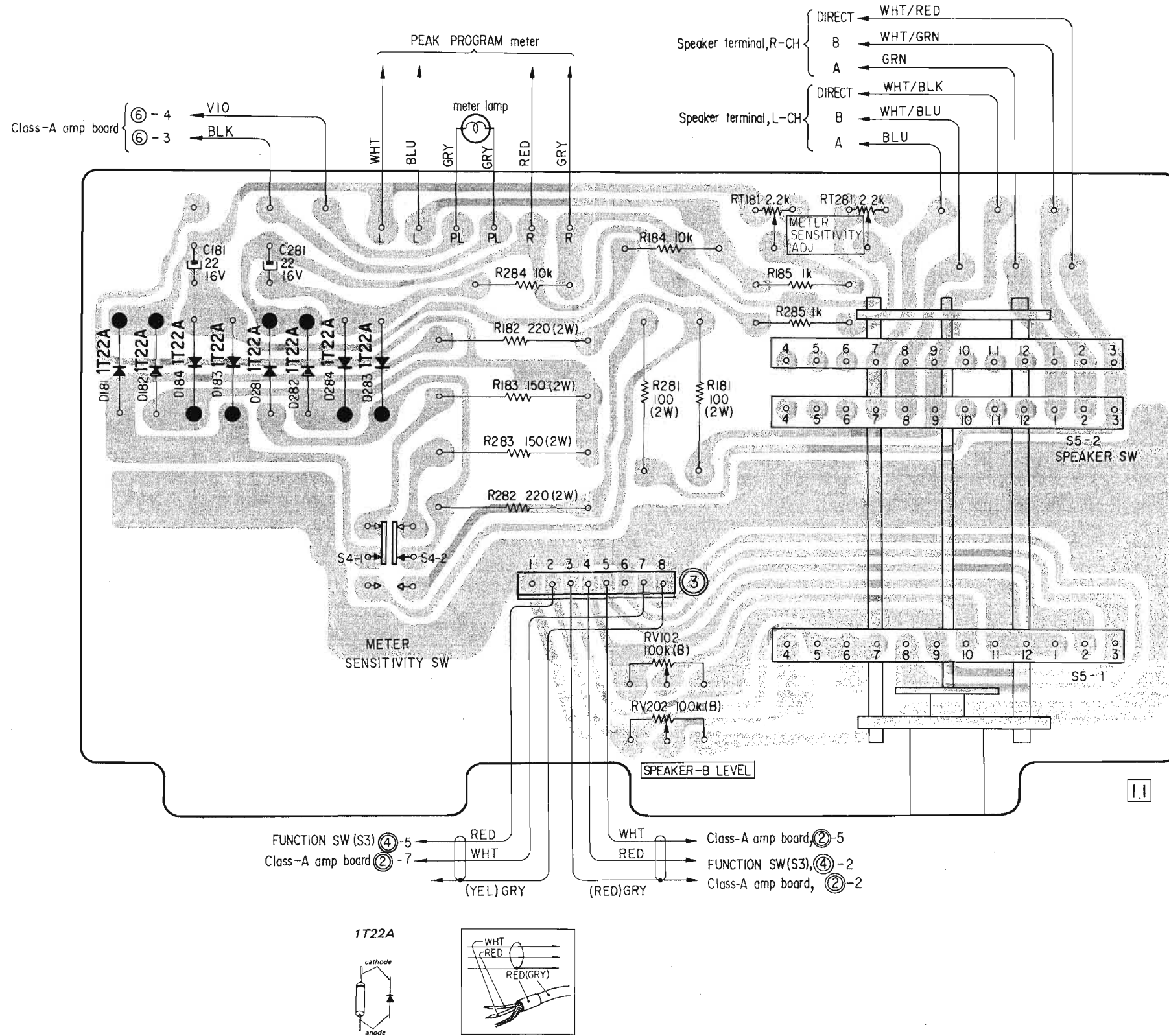

# TAN-8550 TAN-8550

## 4-4. MOUNTING DIAGRAM — Class-B Power Amplifier Board — — Conductor Side —

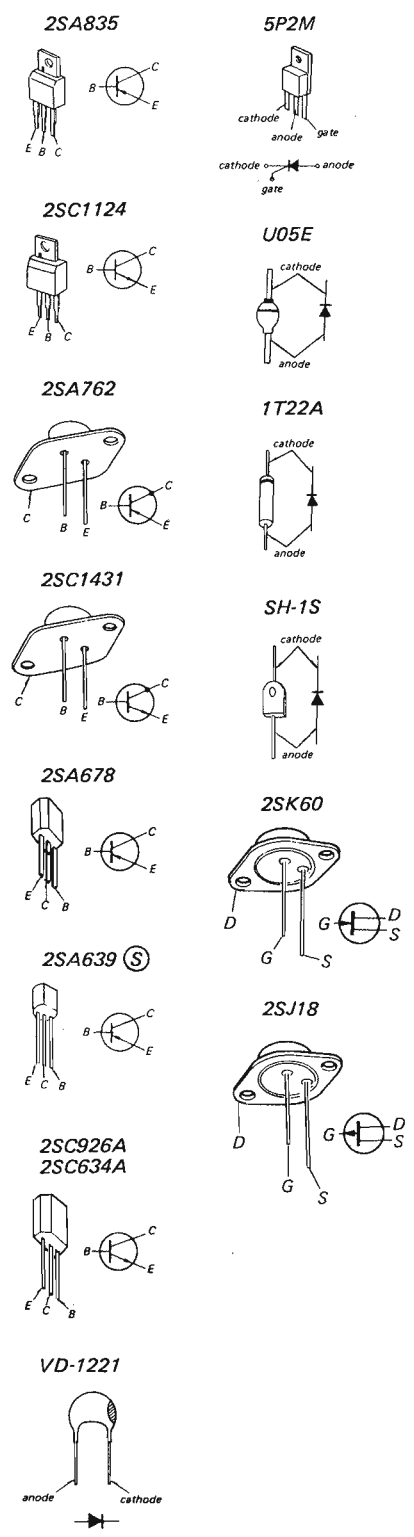

### L-CH

Note: R-CH is the same as L-CH.  
The reference numbers in R-channel start from 750's.

Q717~Q722	*R725, 775	*R 731, 732 781, 782	a	b
2SK60 } 2SJ18 }	-53	33k	1.8k	10.0V ~ 12.5V
"	-54	33k	1.5k	12.5V ~ 15.0V
"	-55	33k	1.2k	15.0V ~ 17.5V
"	-56	30k	1k	17.5V ~ 20.0V
"	-57	30k	1k	20.0V ~ 22.5V
"	-58	30k	820	22.5V ~ 25.0V
				9.4V ~ 11.9V
				11.9V ~ 14.4V
				14.4V ~ 16.9V
				16.9V ~ 19.4V
				19.4V ~ 21.9V
				21.9V ~ 24.4V

Note: ( ) mark shows the lead wire of R channel.

### L-CH 3

### R-CH 5

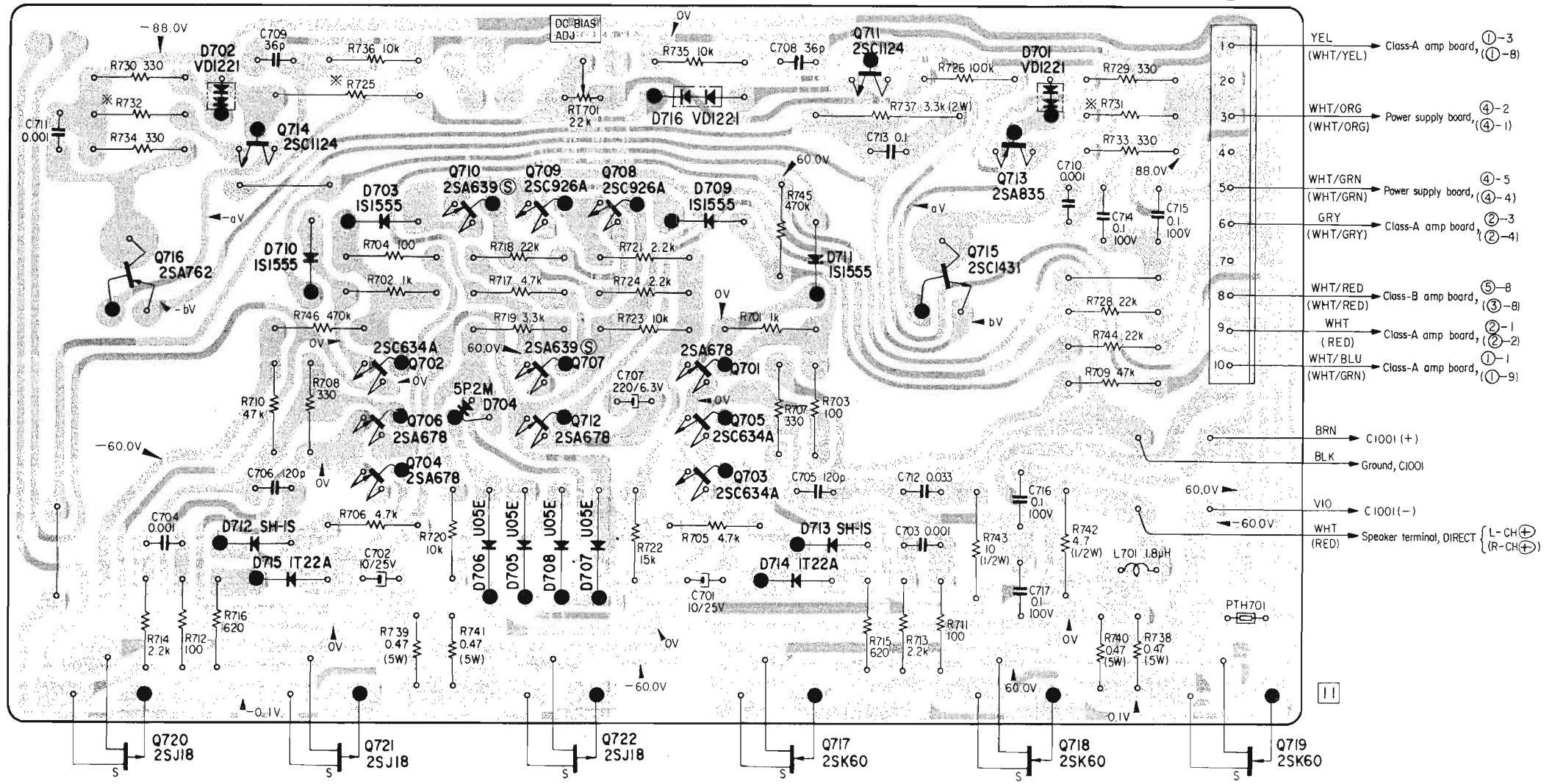

	Q714		Q710	Q709	Q708	Q711	Q713
Q	Q716	Q702	Q707	Q712	Q701	Q705	Q703
	Q720	Q721	Q722	Q717	Q715	Q718	Q719
D	D702	D710	D703	D704	D716	D709	D701
	D712	D715	D706	D705	D708	D707	D711
					D714	D713	

4-5. MOUNTING DIAGRAM – Class-A Power Amplifier Board –  
– Conductor Side –

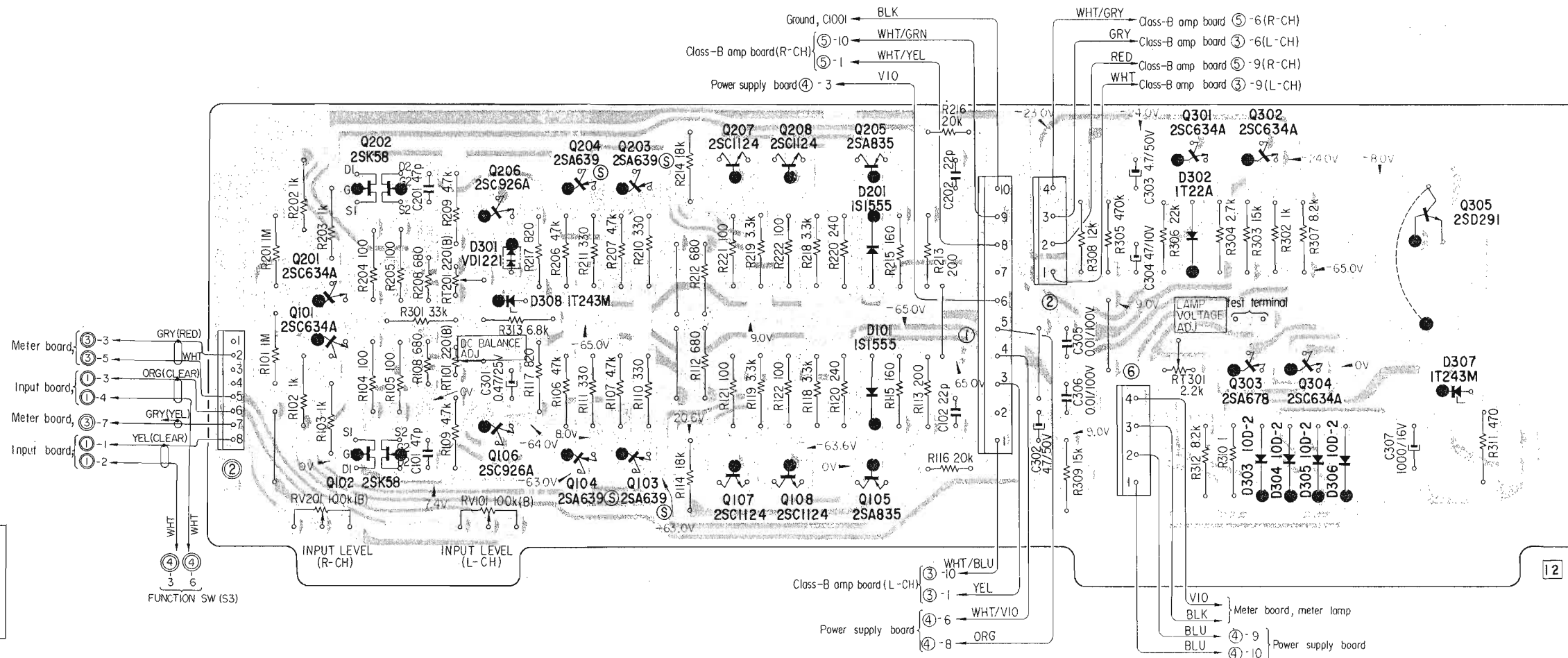
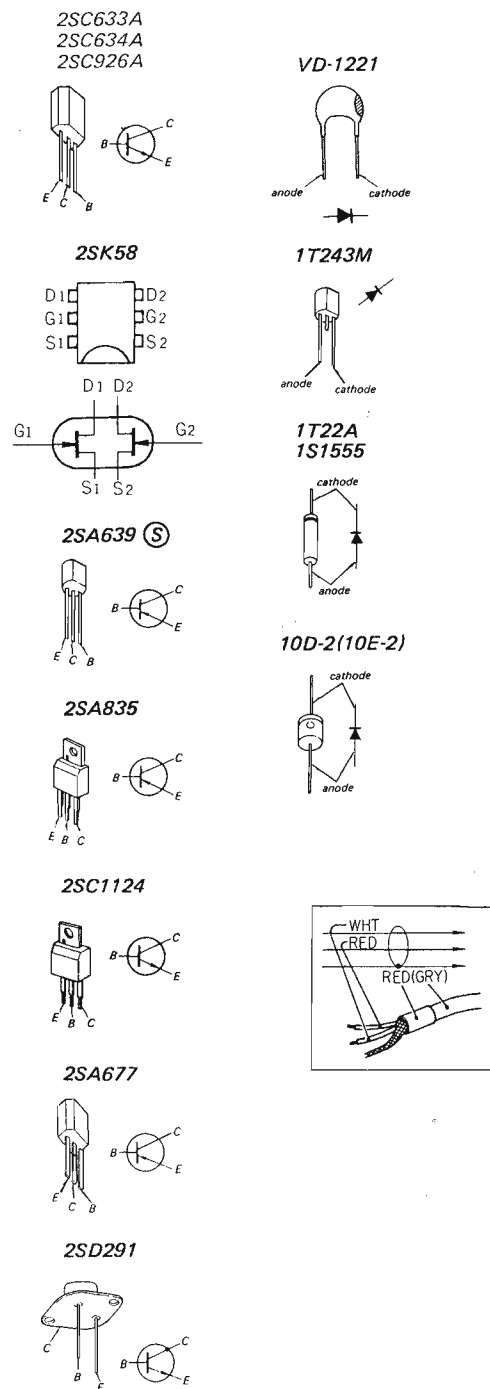

Transistor	
Q202	Q206
Q204	Q203
Q207	Q208
Q205	
Q301	Q302
Q303	Q304
Q305	Q305
Q101	
Q102	Q106
Q104	Q103
Q107	Q108
Q105	

Diode	
D301	D308
D201	D101
D302	
D303	D304
D305	D306
D307	

# TAN-8550 TAN-8550

## 4-6. SCHEMATIC DIAGRAM

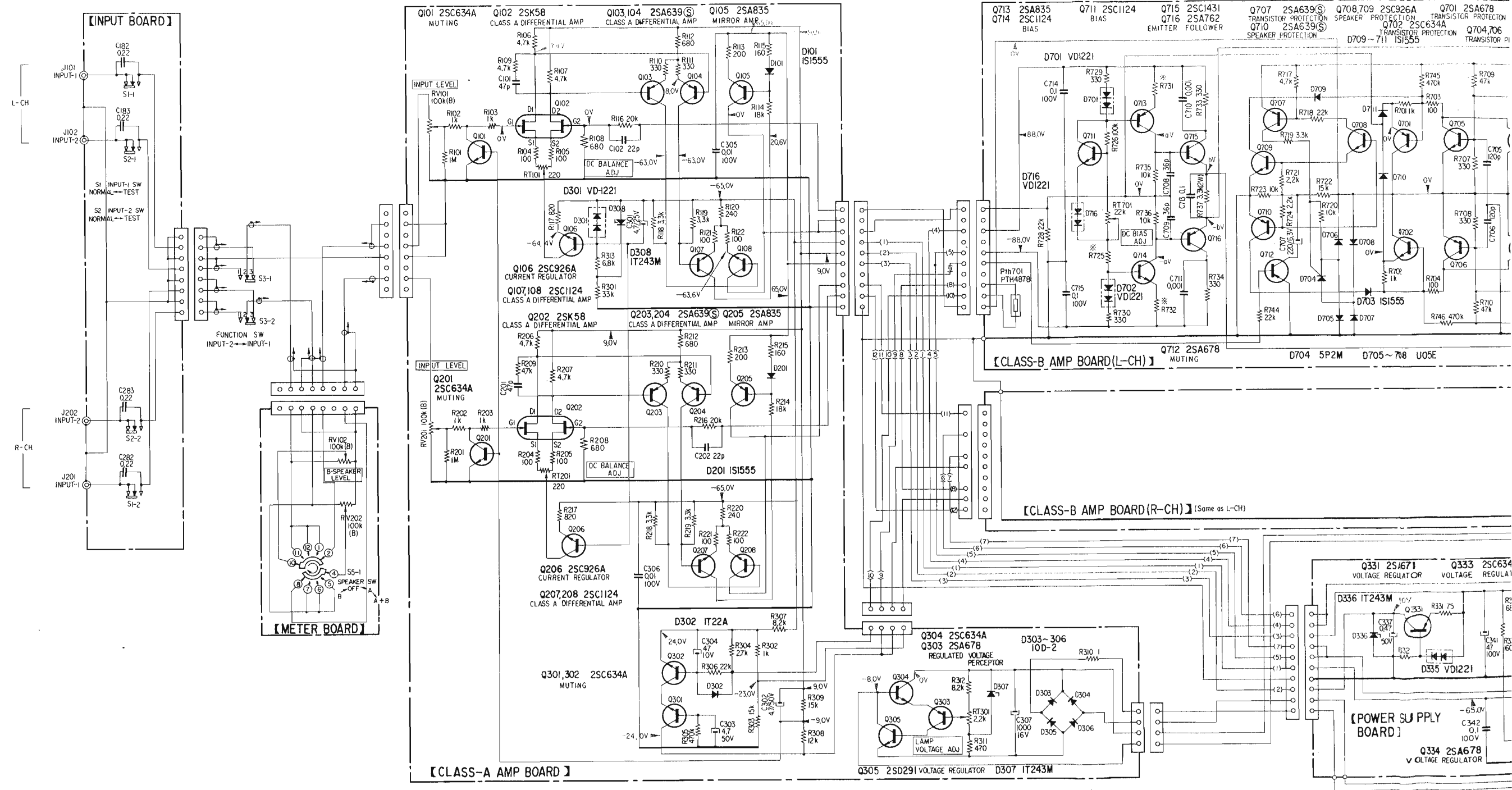

Ref. No.	Description	Position
S1	INPUT-1	NORMAL
S2	INPUT-2	NORMAL
S3	FUNCTION	INPUT-1
S4	METER SENSITIVITY	x1
S5	SPEAKER	B
S6	POWER	ON

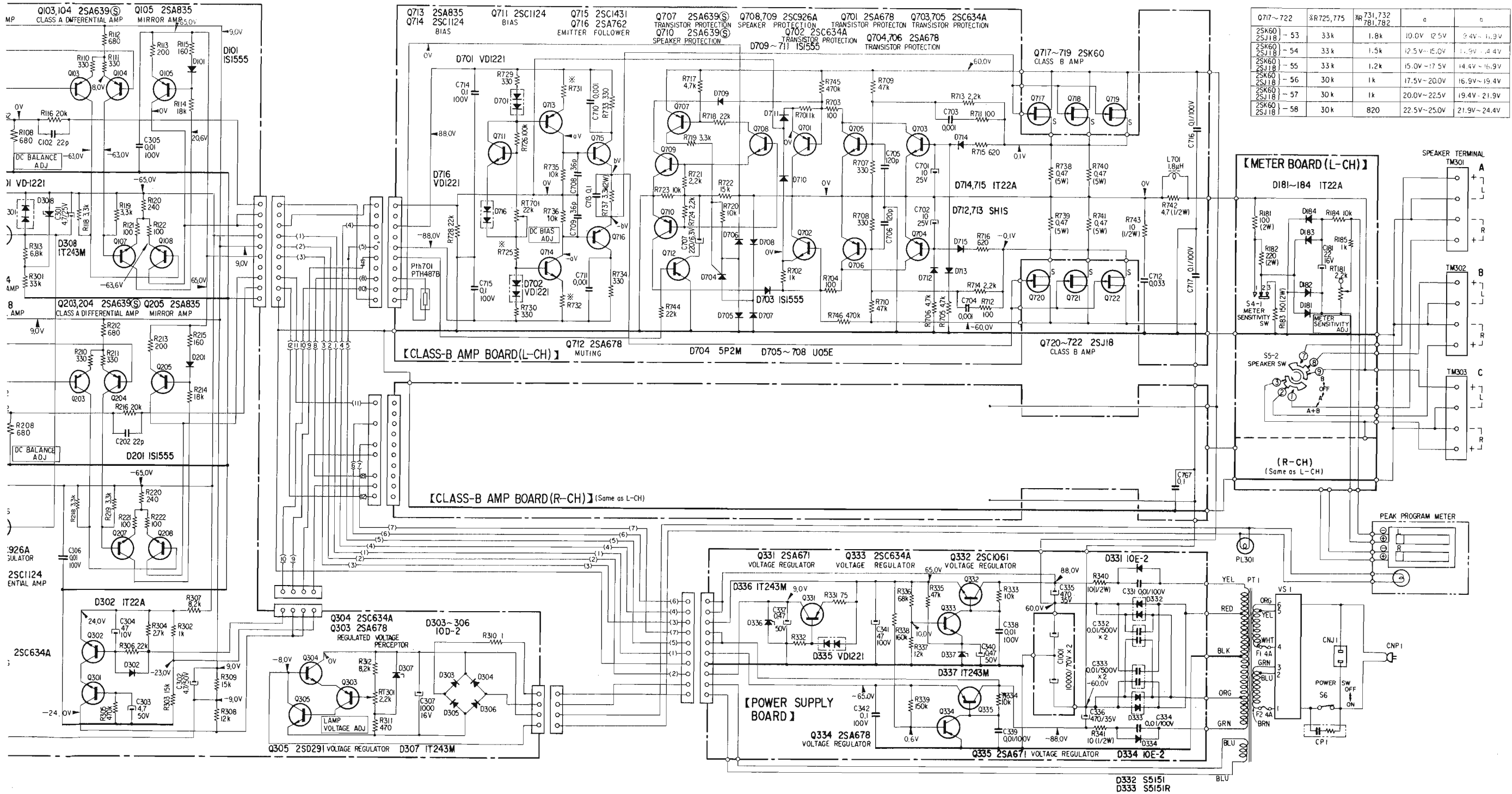

Q717~722	R725,775	R731,732 781,782	0	0
2SK60 2SJ18	-53	33k	1.8k	10.0V 12.5V 2.4V-1.9V
2SK60 2SJ18	-54	33k	1.5k	12.5V-15.0V 1.5V-1.4V
2SK60 2SJ18	-55	33k	1.2k	15.0V-17.5V 1.4V-1.6V
2SK60 2SJ18	-56	30k	1k	17.5V-20.0V 1.6V-1.4V
2SK60 2SJ18	-57	30k	1k	20.0V-22.5V 1.9V-2.1V
2SK60 2SJ18	-58	30k	820	22.5V-25.0V 2.1V-2.4V

**Note:**  
 All resistance values are in ohms. (k = 1,000, M = 1,000 k)  
 All capacitance values are in  $\mu$ F except as indicated with p, which means  $\mu$ F.  
 All voltages are dc measured with a VOM which has an input impedance of 20 k ohms/volt. No signal in.  
 Voltage variations may be noted due to normal production tolerances.

SECTION 5  
EXPLODED VIEWS

MEMO

(1)

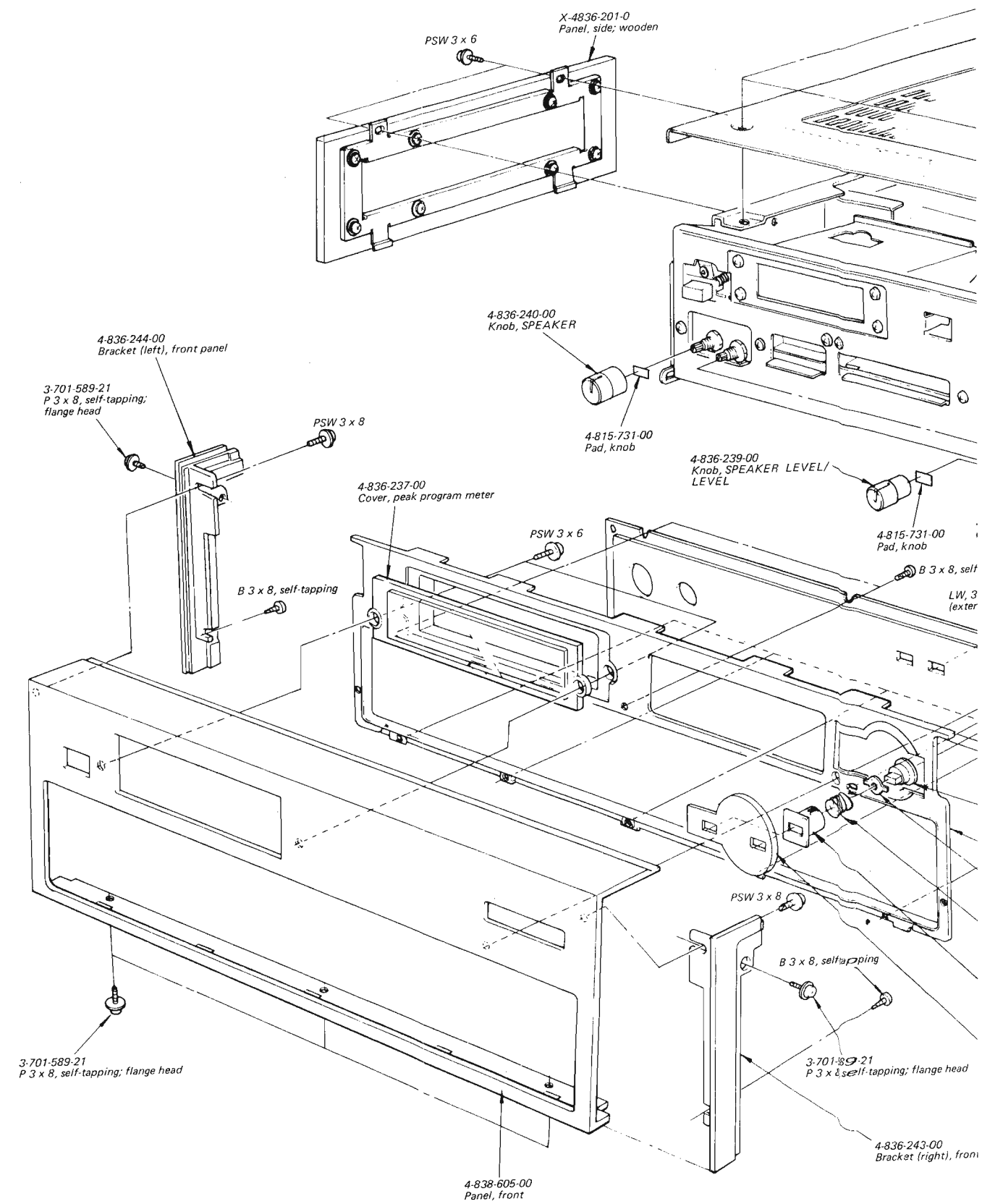







# TAN-8550 TAN-8550

(2)

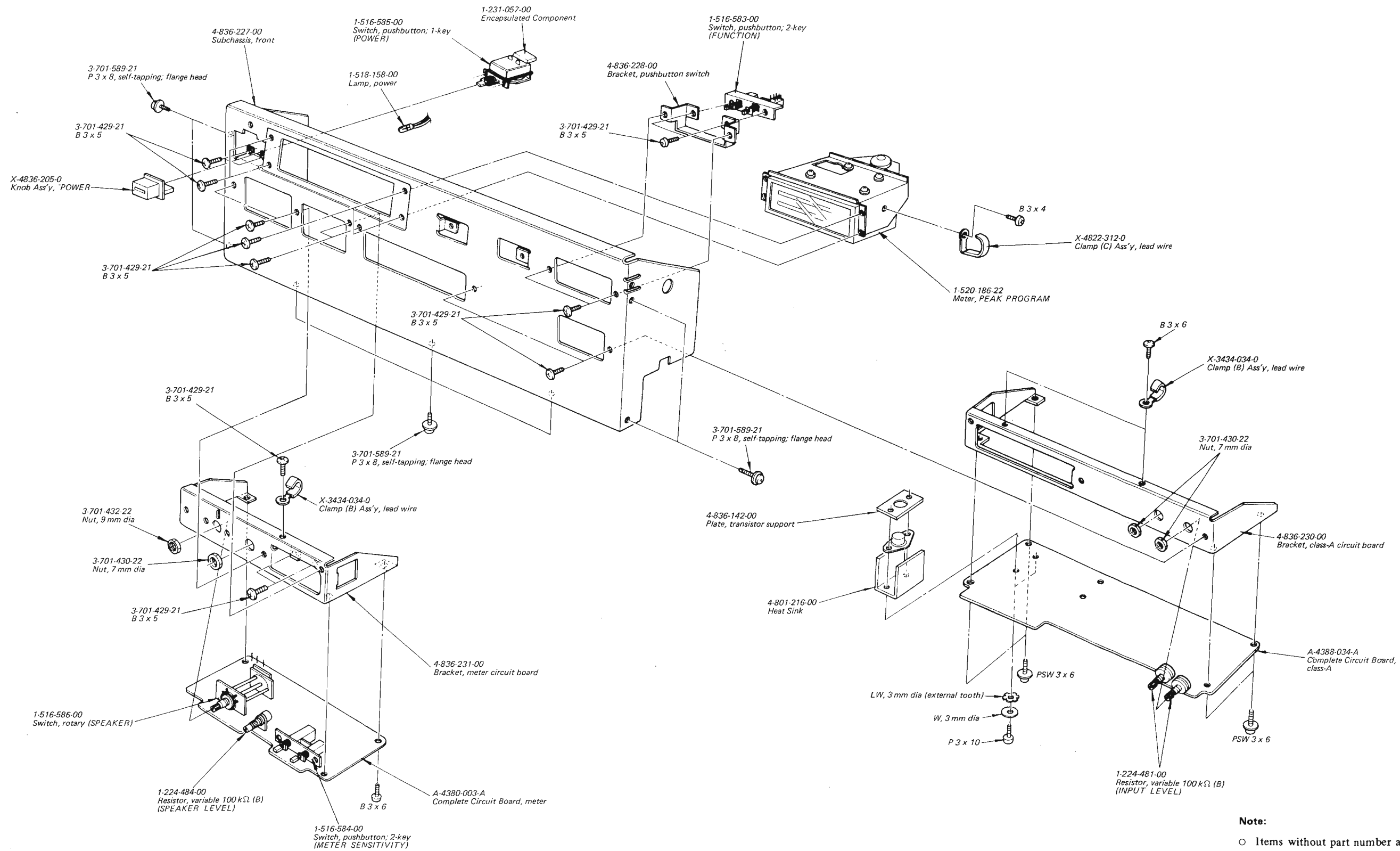

**Note:**

- Items without part number and description are not available.
- All screws are Phillips (cross recess) type unless otherwise noted.
- (-) = slotted head

# TAN-8550 TAN-8550

(3)

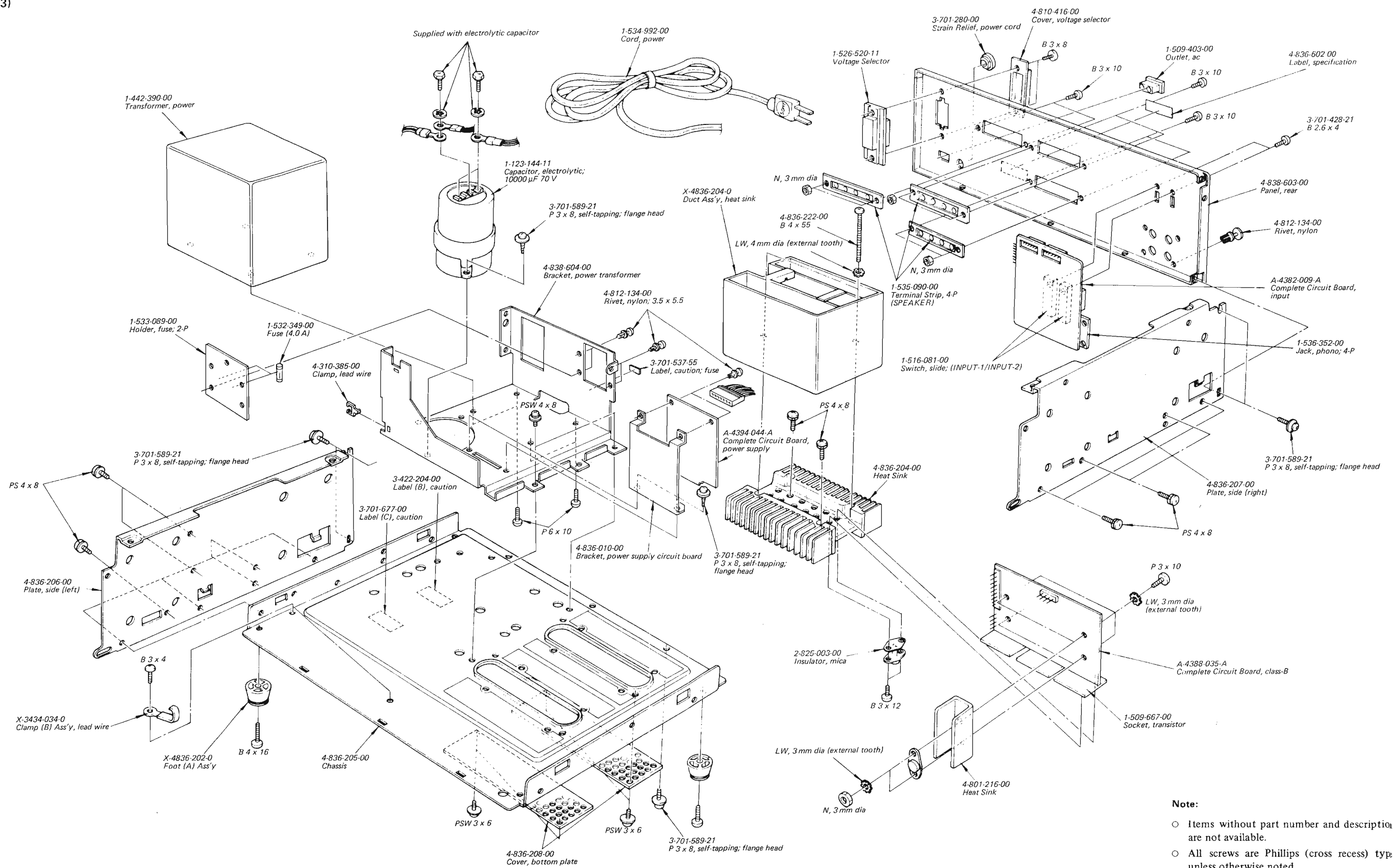

- Note:**
- Items without part number and description are not available.
  - All screws are Phillips (cross recess) type unless otherwise noted.
  - (-) = slotted head

**SECTION 6  
ELECTRICAL PARTS LIST**

<u>Ref. No.</u>	<u>Part No.</u>	<u>Description</u>	<u>Ref. No.</u>	<u>Part No.</u>	<u>Description</u>
<b>COMPLETE CIRCUIT BOARDS</b>			Q713(Q763)		2SA835
	A-4380-003-A	Meter	Q714(Q764)		2SC1124
	A-4382-009-A	Input	Q715(Q765)		2SC1431
	A-4388-034-A	Class A amp	Q716(Q766)		2SA762
	A-4388-035-A	Class B amp	Q717(Q767)		2SK60 (FET)
	A-4394-044-A	Power Supply	Q718(Q768)		2SK60 (FET)
			Q719(Q769)		2SK60 (FET)
			Q720(Q770)		2SJ18 (FET)
			Q721(Q771)		2SJ18 (FET)
			Q722(Q772)		2SJ18 (FET)
<b>SEMICONDUCTORS</b>					
<b>Transistors</b>					
Q101(Q201)		2SC634A			
Q102(Q202)		2SK58 (FET)			
Q103(Q203)		2SA639S			
Q104(Q204)		2SA639S			
Q105(Q205)		2SA835			
Q106(Q206)		2SC926A			
Q107(Q207)		2SC1124			
Q108(Q208)		2SC1124			
Q301, Q302		2SC634A			
Q303		2SA678			
Q304		2SC634A			
Q305		2SD291			
Q331		2SA671			
Q332		2SC1061			
Q333		2SC634A			
Q334		2SA678			
Q335		2SA671			
Q701(Q751)		2SA678			
Q702(Q752)		2SC634A			
Q703(Q753)		2SC634A			
Q704(Q754)		2SA678			
Q705(Q755)		2SC634A			
Q706(Q756)		2SA678			
Q707(Q757)		2SA639S			
Q708(Q758)		2SC926A			
Q709(Q759)		2SC926A			
Q710(Q760)		2SA639S			
Q711(Q761)		2SC1124			
Q712(Q762)		2SA678			
				<b>Diodes</b>	
			D101(D201)		1S1555
			D181~D184 (D281~D284)		1T22A
			D301		VD-1221
			D302		1T22A
			D303~D306		10D-2
			D307, D308		1T243M
			D331		10E-2
			D332		S5151
			D333		S5151R
			D334		10E-2
			D335		VD-1221
			D336, D337		1T243M
			D701(D751)		VD-1221
			D702(D752)		VD-1221
			D703(D753)		1S1555
			D704(D754)		5P2M
			D705 ~ D708 (D755 ~ D758)		U05E
			D709 ~ D711 (D759 ~ D761)		1S1555
			D712(D762)		SH-1S
			D713(D763)		SH-1S
			D714(D764)		1T22A
			D715(D765)		1T22A
			D716(D766)		VD-1221

<u>Ref. No.</u>	<u>Part No.</u>	<u>Description</u>
<b>TRANSFORMER AND INDUCTORS</b>		
L701(L751)	1-407-592-00	Microinductor, 1.8 $\mu$ H
PT1	1-442-390-00	Transformer, power

### CAPACITORS

Capacitors here are in  $\mu$ F, mylar type unless otherwise noted (p =  $\mu$  $\mu$ , elect = electrolytic). The working voltages of 50 volts or less are omitted except for electrolytic type.

C101(C201)	1-101-880-11	47p		ceramic
C102(C202)	1-102-959-11	22p		ceramic
C181(C281)	1-121-990-11	22	16V	elect
C182(C282)	1-105-689-12	0.22		
C183(C283)	1-105-689-12	0.22		
C301	1-121-395-11	4.7	25V	elect
C302, C303	1-121-396-11	4.7	50V	elect
C304	1-121-352-11	47	10V	elect
C305, C306	1-108-657-12	0.01	100V	
C307	1-121-245-11	1000	16V	elect
C331	1-105-713-12	0.01	100V	
C332, C333	1-102-355-11	0.01(2 pieces)	500V	ceramic
C334	1-105-713-12	0.01	100V	
C335, C336	1-121-941-11	470	35V	elect
C337	1-121-726-11	0.47	50V	elect
C338, C339	1-105-713-12	0.01	100V	
C340	1-121-726-11	0.47	50V	elect
C341	1-123-083-11	47	100V	elect
C342	1-105-725-12	0.1	100V	
C701(C751)	1-121-398-11	10	25V	elect
C702(C752)	1-121-398-11	10	25V	elect
C703(C753)	1-105-661-12	0.001		
C704(C754)	1-105-661-12	0.001		
C705(C755)	1-102-816-11	120p		ceramic
C706(C756)	1-102-816-11	120p		ceramic
C707(C757)	1-121-419-11	220	6.3V	elect
C708(C758)	1-102-964-11	36p		ceramic
C709(C759)	1-102-964-11	36p		ceramic
C710(C760)	1-105-661-12	0.001		

<u>Ref. No.</u>	<u>Part No.</u>	<u>Description</u>	
C711(C761)	1-105-661-12	0.001	
C712(C762)	1-105-679-12	0.033	
C713(C763)	1-105-685-12	0.1	
C714(C764)	1-105-725-12	0.1	100V
C715(C765)	1-105-725-12	0.1	100V
C716(C766)	1-105-725-12	0.1	100V
C717(C767)	1-105-725-12	0.1	100V
C1001	1-123-144-11	10000	70V elect

### RESISTORS

All resistors are in  $\Omega$ .  $\pm 5\%$ ,  $\frac{1}{4}$  W, carbon resistors (except special type) are omitted. Check schematic diagram for the resistance values.  
(k = 1000, M = 1000 k)

R108(R208)	1-212-529-11	680	$\pm 1\%$	metal-oxide
R116(R216)	1-212-685-11	20 k	$\pm 1\%$	metal-oxide
R181(R281)	1-206-640-11	100		2 W metal-oxide
R182(R282)	1-206-648-11	220		2 W metal-oxide
R183(R283)	1-206-644-11	150		2 W metal-oxide
R336	1-212-698-11	68 k	$\pm 1\%$	metal-oxide
R337	1-212-680-11	12 k	$\pm 1\%$	
R340, R341	1-202-525-11	10		$\frac{1}{2}$ W composition
R725(R775)	1-206-699-11	30 k		2 W metal-oxide
R725(R775)	1-206-700-11	33 k		2 W metal-oxide
R737(R787)	1-206-676-11	3.3 k		2 W
R738(R788)	1-217-158-11	0.47		5 W wirewound
R739(R789)	1-217-158-11	0.47		5 W wirewound
R740(R790)	1-217-158-11	0.47		5 W wirewound
R741(R791)	1-217-158-11	0.47		5 W wirewound
R742(R792)	1-202-517-11	4.7		$\frac{1}{2}$ W composition
R743(R793)	1-202-525-11	10		$\frac{1}{2}$ W composition
RT101 (RT201)	1-224-550-00	220		adjustable (dc balance adj.)
RT181 (RT281)	1-224-250-00	2.2 k		adjustable (meter sens. adj.)
RT301	1-224-250-00	2.2 k		adjustable (lamp voltage adj.)

<u>Ref. No.</u>	<u>Part No.</u>	<u>Description</u>
RT701 (RT751)	1-224-491-00	22 k, adjustable (dc bias adj.)
RV101 (RV201)	1-224-481-00	100 k (B), variable (INPUT LEVEL)
RV102 (RV202)	1-224-484-00	100 k (B), variable (SPEAKER LEVEL)
<b>SWITCHES</b>		
S1, S2	1-516-081-00	Slide (INPUT)
S3	1-516-583-00	Pushbutton, 2-key (FUNCTION)
S4	1-516-584-00	Pushbutton, 2-key (METER SENS.)
S5	1-516-586-00	Rotary (SPEAKER SELECTOR)
S6	1-516-585-00	Pushbutton (POWER)
<b>MISCELLANEOUS</b>		
CNJ1	1-509-403-00	Outlet, ac

<u>Ref. No.</u>	<u>Part No.</u>	<u>Description</u>
CNP1	1-534-992-00	Cord, power
CP1	1-231-057-00	Encapsulated Component
F1, F2	1-532-349-00	Fuse, 4 A
J101(J201)	1-536-352-00	Jack, phono; 4-p
J102(J202)		
PL301	1-518-158-00	Lamp, power
TM301~ TM303	1-535-090-00	Terminal Strip (SPEAKER)
VS1	1-526-520-11	Selector, voltage
	1-509-667-00	Socket, transistor
	1-520-186-22	Meter, peak program
	1-533-089-00	Holder, fuse; 2-p
	1-536-354-00	Pin, terminal
Pth701 Pth751	1-800-340-00	Thermistor (Positive)

**ACCESSORIES AND PACKING MATERIALS**

<u>Part No.</u>	<u>Description</u>
X-3701-029-0	Card Ass'y, warranty
3-701-020-00	Bag, polyethylene; instruction manual
3-701-300-00	Bag, polyethylene; unit
3-701-730-00	Bag, polyethylene; IBM card
3-701-742-00	Card, IBM
3-780-480-21	Manual, instruction
4-836-257-00	Cushion, side
4-836-258-00	Cushion, lower
4-836-259-00	Cushion
4-838-607-00	Carton