

TA-V3

*AEP Model
UK Model
E Model*



INTEGRATED STEREO AMPLIFIER

SPECIFICATIONS

Amplifier section

Continuous RMS power output

At 1 kHz

38 + 38 watts (5% THD, 6 ohms)

33 + 33 watts (0.09% THD, 6 ohms)

At 20 Hz - 20 kHz, 0.09% THD

25 + 25 watts (6 ohms)

According to DIN 45500

25 + 25 watts (6 ohms)

Power bandwidth (IHF)

10 Hz - 30 kHz

Dynamic headroom 1.8 dB ('78 IHF)

Harmonic distortion Less than 0.09% at rated output

Intermodulation (IM) distortion

(60 Hz : 7 kHz = 4 : 1) Less than 0.09% at rated output

Frequency response PHONO : RIAA equalization curve ± 0.5 dB

TUNER

CD/AUX } 15 Hz - 50 kHz ± 0.3 dB

TAPE }

Residual noise Less than 100 μ V (6 ohms, network A)

Damping factor 30 (6 ohms, 1 kHz)

Inputs

	Sensitivity	Impedance	Maximum input capability (1 kHz)	S/N (weighting network, input level)
PHONO	2.5 mV	50 k Ω	120 mV	73 dB 75 dB* (A, 2.5 mV)
TUNER CD/AUX TAPE	150 mV	50 k Ω	—	98 dB 80 dB* (A, 150 mV)

* '78 IHF

Outputs

REC OUT

Voltage 150 mV

Impedance 4.7 kilohms

SPEAKER

Accepts speakers of 6 - 16 ohms.

HEADPHONES

Accepts low and high impedance headphones.

Tone controls

BASS

± 8 dB at 100 Hz

TREBLE

± 8 dB at 10 kHz

Loudness (att. 30 dB) +8 dB at 100 Hz

— Continued on page 2 —

SAFETY-RELATED COMPONENT WARNING!!

COMPONENTS IDENTIFIED BY SHADING AND MARK  ON THE SCHEMATIC DIAGRAMS AND IN THE PARTS LIST ARE CRITICAL TO SAFE OPERATION. REPLACE THESE COMPONENTS WITH SONY PARTS WHOSE PART NUMBERS APPEAR AS SHOWN IN THIS MANUAL OR IN SUPPLEMENTS PUBLISHED BY SONY.



SONY[®]
SERVICE MANUAL

FEATURES

General

System	Preamplifier section : low-noise NF type equalizer amp.; NF type tone control Power amplifier section : quasi-complementary SEPP OTL OCL amplifier with all stages direct coupled
Power requirements	AEP model: 220 V ac (240 V ac adjustable by authorized Sony personnel), 50/60 Hz UK model: 240 V ac (220 V ac adjustable by authorized Sony personnel), 50/60 Hz E model: 120, 220 or 240 V ac adjustable, 50/60 Hz
Power consumption	70 watts
AC outlets	AEP, UK model: 1 switched, 100 watts max. E model: 2 switched, total 100 watts max. 1 unswitched, 100 watts max.
Dimensions	Approx. 355 × 80 × 255 mm (w/h/d) (14 × 3 ¹ / ₄ × 10 inches) including projecting parts and controls
Weight	Approx. 4.5 kg (9 lbs 15 oz) net Approx. 5.0 kg (11 lbs 1 oz) in shipping carton

The Sony TA-V3 integrated stereo amplifier provides dynamic high-fidelity sound despite a remarkably compact cabinet.

- Slim, smart case.
- Spot-character function display to show quite clearly which function is in use.
- Loudness switch to compensate for human ear's reduced response at low volume.
- CD/AUX inputs for connecting a CD (compact disc) player.
- Soft-touch function switches.
- Cord clamp for ensuring tidy arrangement of the cords on the rear panel.

0 dB = 0.775 V

MODEL IDENTIFICATION

— Specification Label —

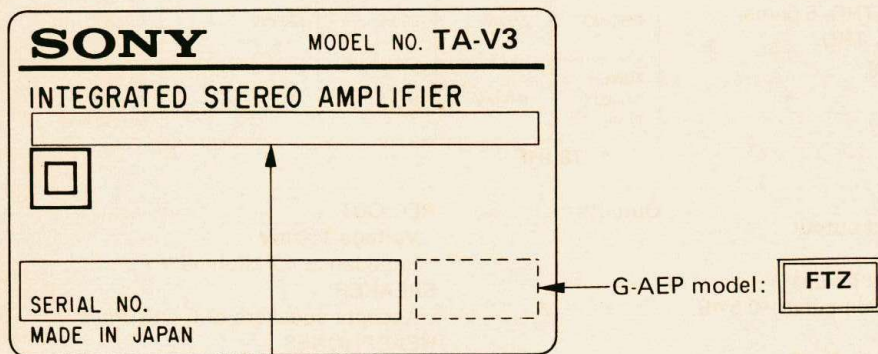

- AEP model: AC: 220V ~ 50/60Hz 70W
- UK model: AC: 240V ~ 50/60Hz 70W
- E model: AC: 120/220/240V ~ 50/60Hz 70W

LOCATION AND FUNCTION OF CONTROLS

Each number in the photo is keyed to the descriptive text.

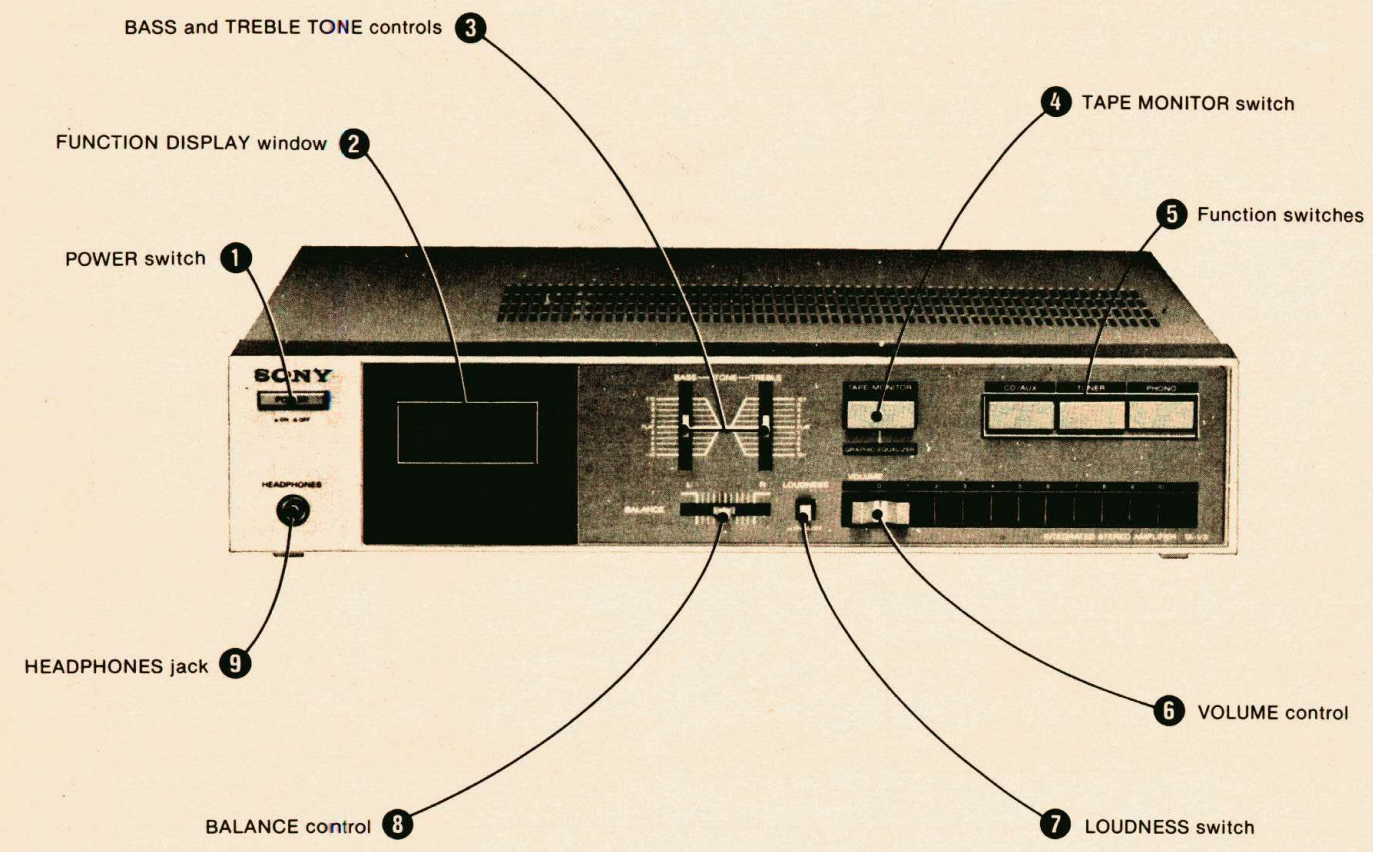

- 1 POWER switch**
Turns the operating power on or off.
- 2 FUNCTION DISPLAY window**
The program in use is displayed here.
- 3 BASS and TREBLE TONE controls**
These levers control the bass and treble response. Sliding the levers towards +10 increases the response and sliding them towards -10 decreases it. The center FLAT position provides a flat response.
- 4 TAPE MONITOR switch**
To listen to a taped program, depress this switch. "TAPE" is displayed in the FUNCTION DISPLAY window, and a playback output from the tape recorder connected to the TAPE RECORDER TAPE jacks can be heard. When the graphic equalizer is connected, depress this switch after selecting the input source with the amplifier function switches. The input selector of the graphic equalizer must be set as required.
- 5 Function switches**
Depress one of these switches to select a desired program source other than a taped program. The program in use is displayed in the FUNCTION DISPLAY window.
PHONO: For record programs (connected to PHONO inputs)
TUNER: For off-the-air programs (connected to TUNER inputs)
CD/AUX: For CD or other auxiliary programs (connected to CD/AUX inputs)

- 6 VOLUME control**
Regulates the overall sound level. Sliding the lever towards 10 increases the volume and sliding it towards 0 decreases the volume. Be sure to lower the volume whenever you turn the amplifier on or off or make system connections.
- 7 LOUDNESS switch**
Normally keep the switch released (\square OFF). When listening to program sources at a low VOLUME control setting, depress the switch (\triangle ON). This loudness control compensates for the human ear's decreased response to very low frequency sound at low volume levels, and provides an apparently uniform response.
- 8 BALANCE control**
Governs the amount of sound coming from each paired speaker to get optimum stereo effect.
- 9 HEADPHONES jack**
Accepts any low or high impedance stereo headphones.

**SECTION 1
OUTLINE**

1-1. BLOCK DIAGRAM

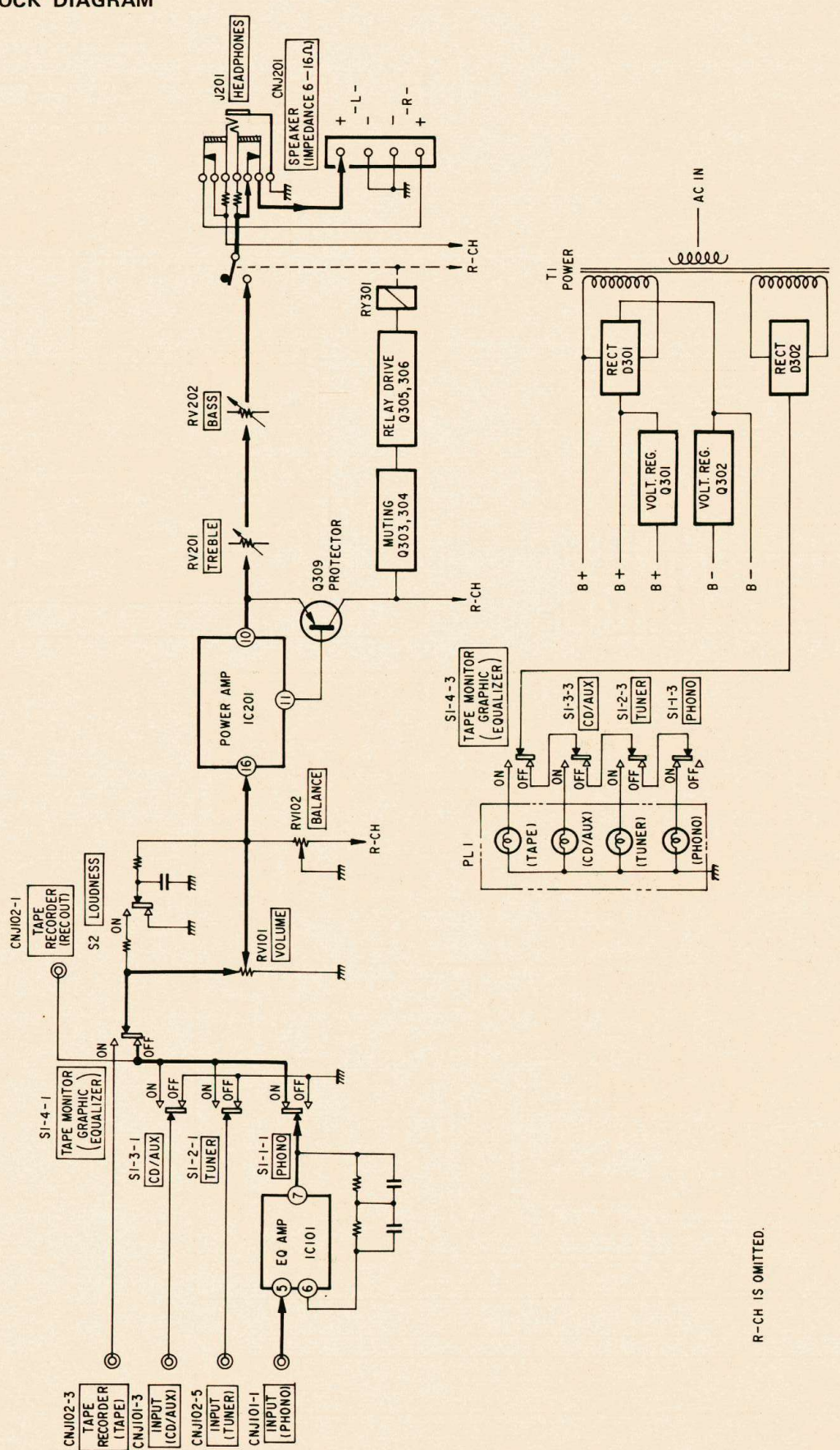

**SECTION 2
DISASSEMBLY**

2-1. REMOVAL

Note: Follow the disassembly procedure in the numerical order given.

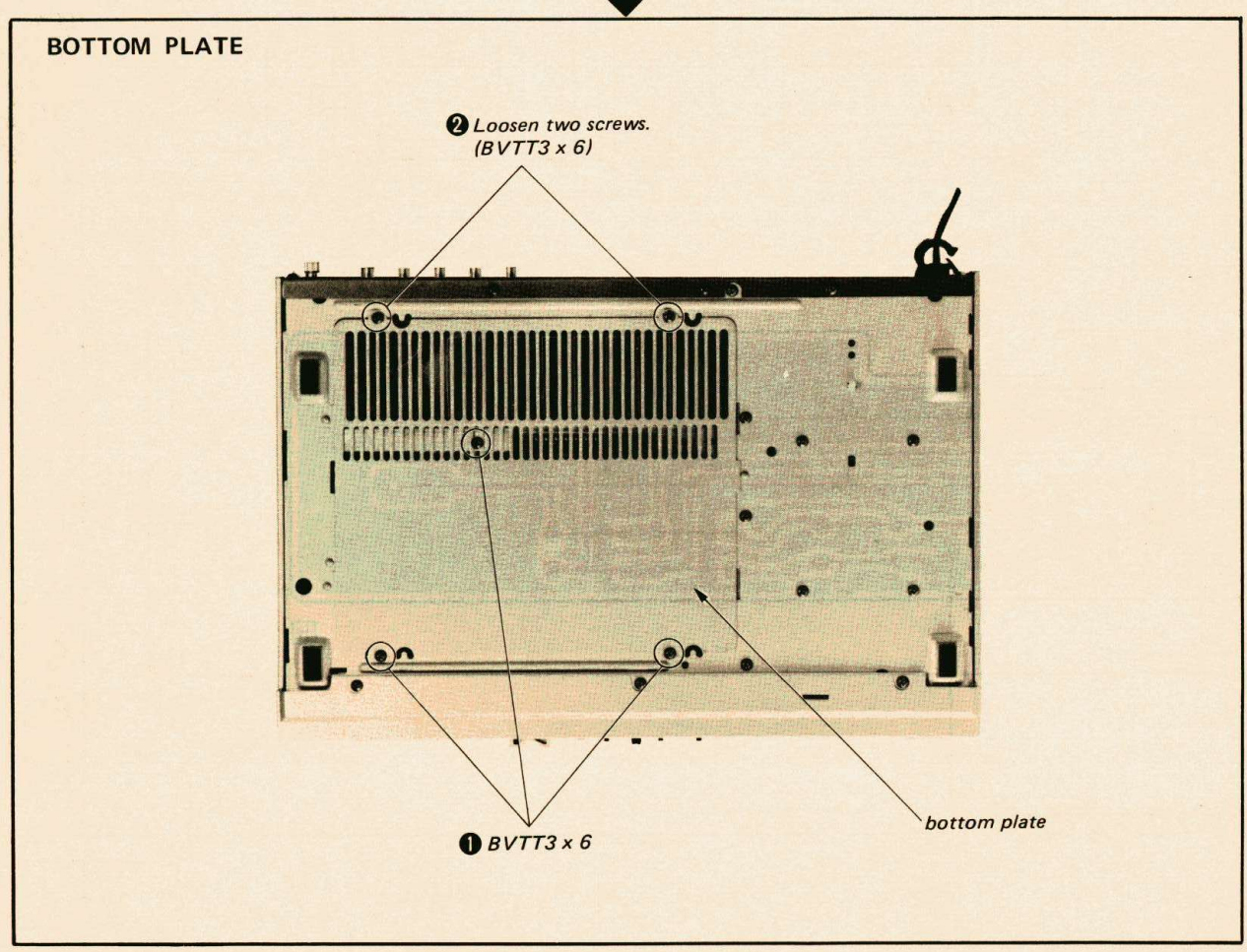
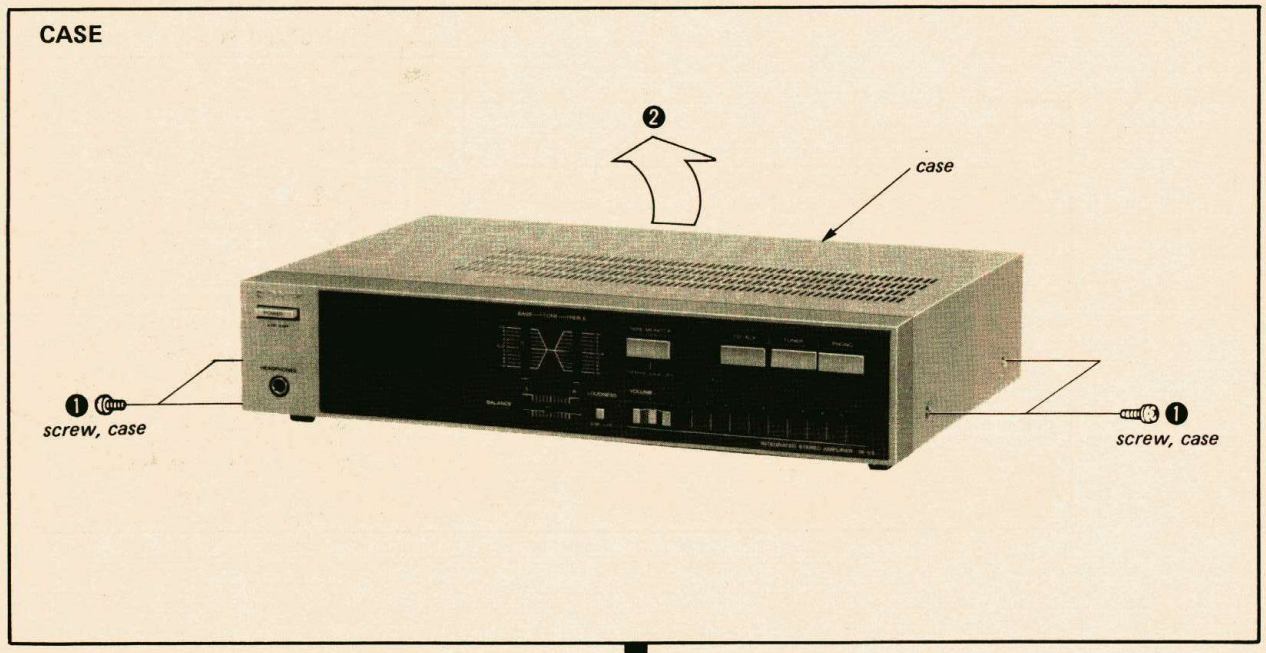

SECTION 3
 DIAGRAMS
 TA-V3 TA-V3

TA-V3 TA-V3

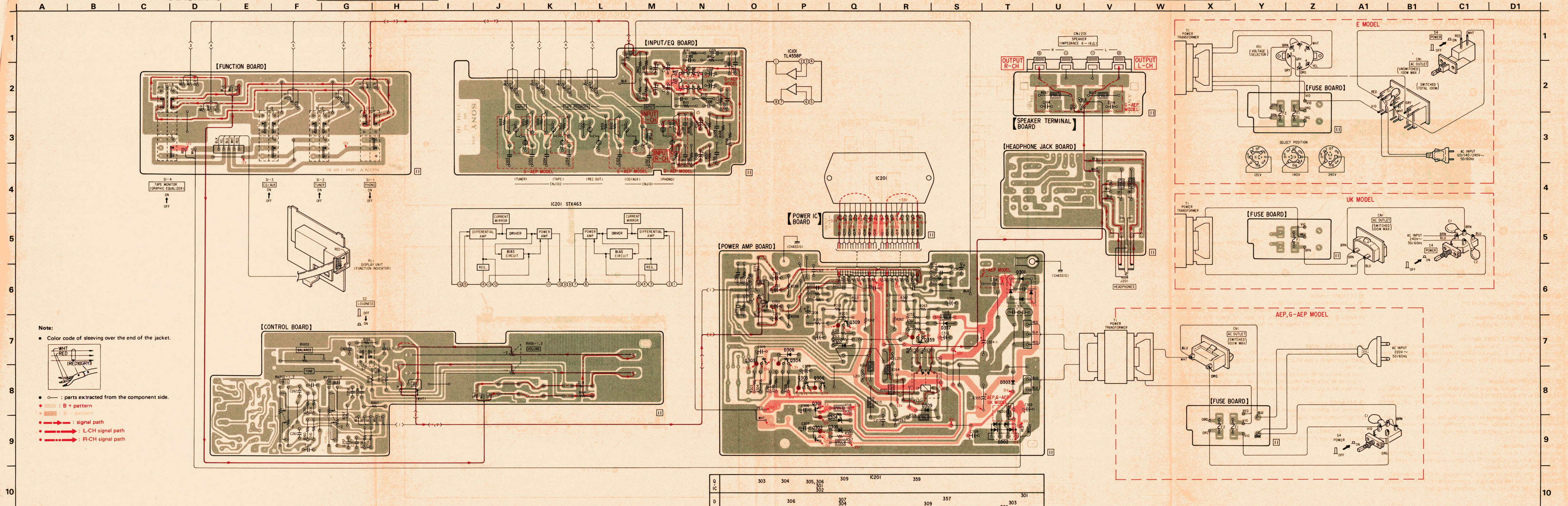

- Note:**
- Color code of sleeving over the end of the jacket.
 - WHT (RED) (GRY)
 - parts extracted from the component side.
 - B + pattern
 - B - pattern
 - signal path
 - L-CH signal path
 - R-CH signal path

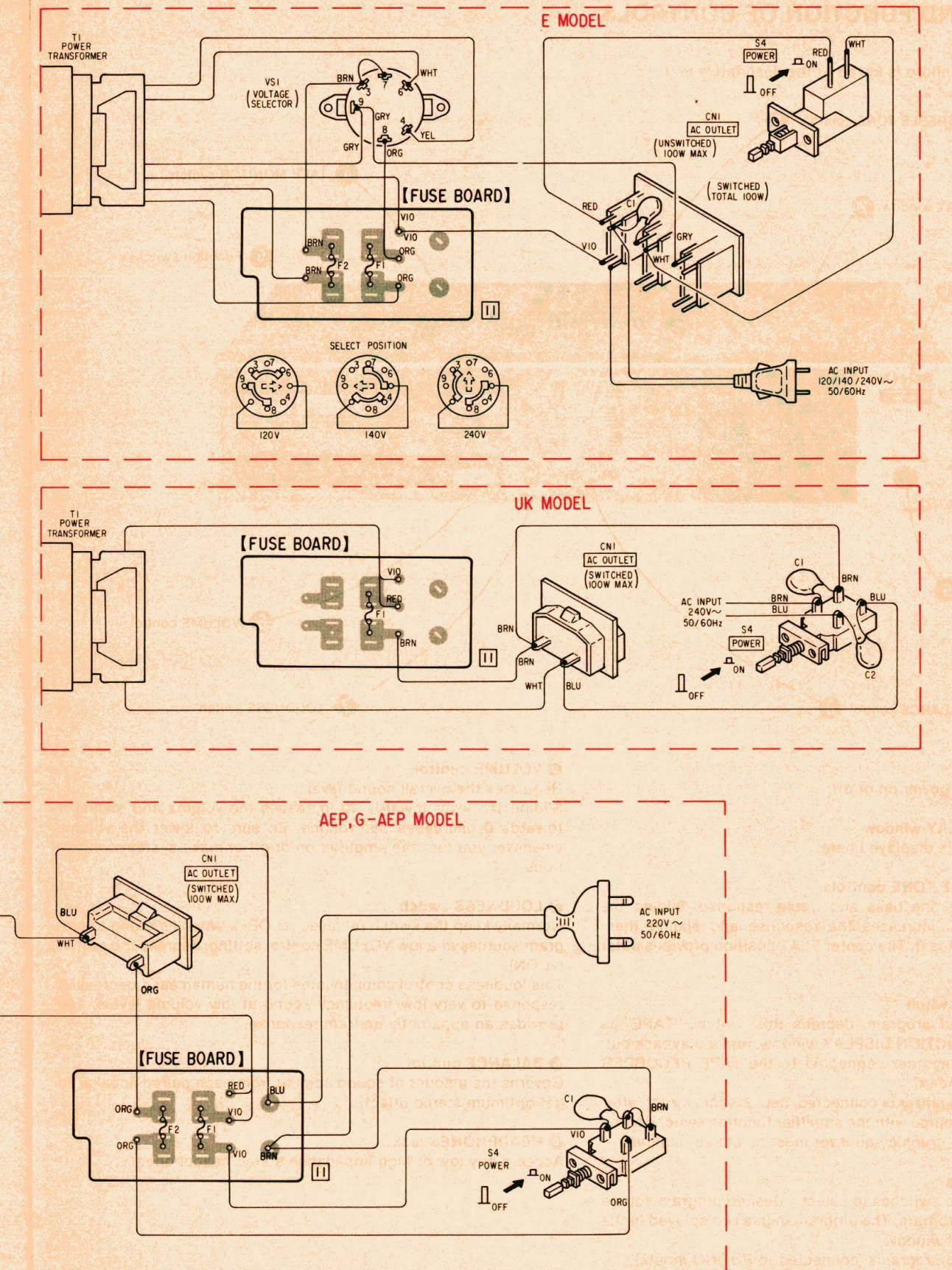

Q	303	304	305, 306	309	IC201	359
IC			302			301
D		306		307, 305		309, 357, 303

3-2. SCHEMATIC DIAGRAM

TA-V3 TA-V3

TA-V3 TA-V3

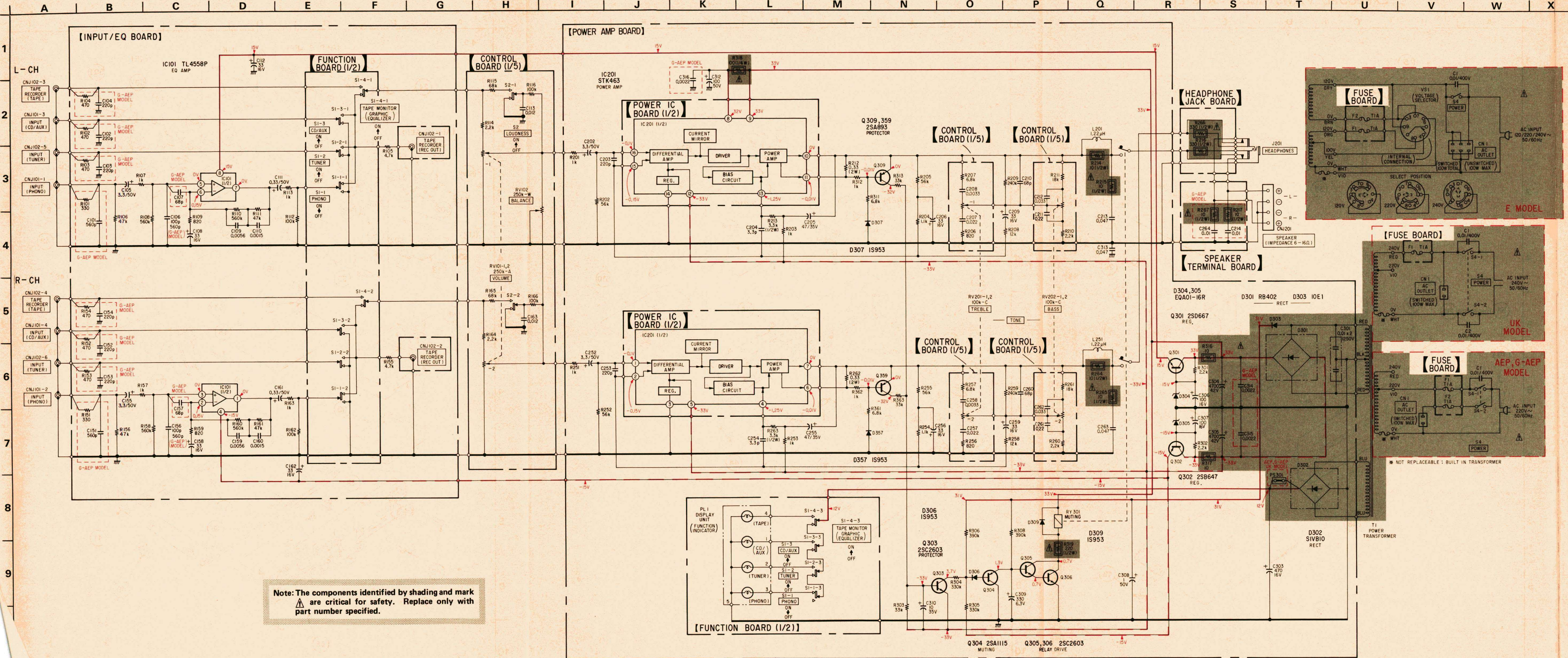

Note: The components identified by shading and mark are critical for safety. Replace only with part number specified.

SEMICONDUCTOR LEAD LAYOUTS

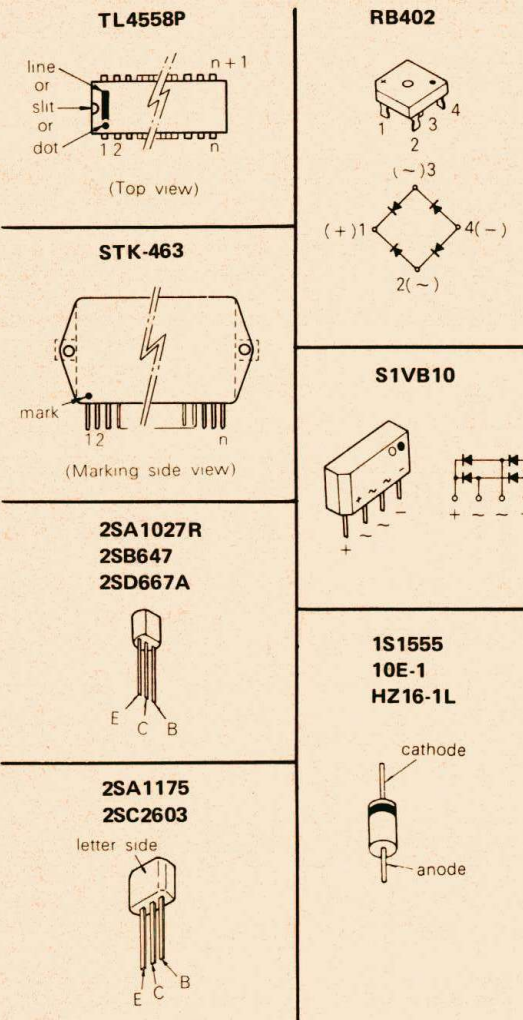

- Note:
- All capacitors are in μF unless otherwise noted. $\text{pF} = \mu\text{F} / 100$.
 - All resistors are in ohms, $\frac{1}{4}\text{W}$ unless otherwise noted. $\text{k}\Omega = 1000\ \Omega$, $\text{M}\Omega = 1000\ \text{k}\Omega$.
 - : nonflammable resistor.
 - : panel designation.
 - : B+ bus.
 - : B- bus.
 - Voltages are dc with respect to ground unless otherwise noted.
 - Readings are taken under no-signal conditions.
 - Voltage variations may be noted due to normal production tolerances.

Ref. No.	Switch	Position
S1	function	PHONO
S2	LOUDNESS	OFF
S4	POWER	OFF

Note: Voltages are measured with a VOM (50k Ω/V).

**SECTION 4
 EXPLODED VIEWS AND PARTS LIST**

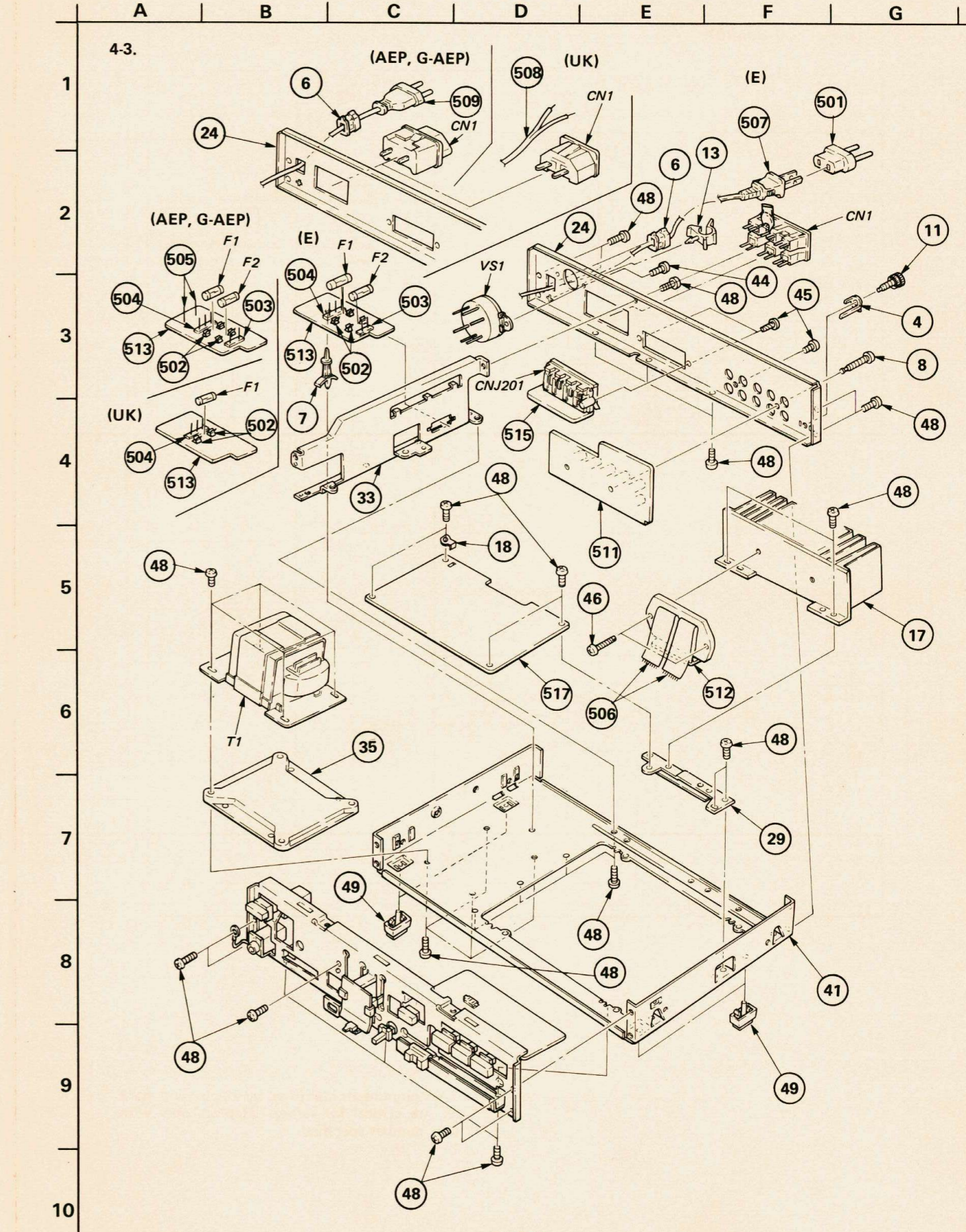
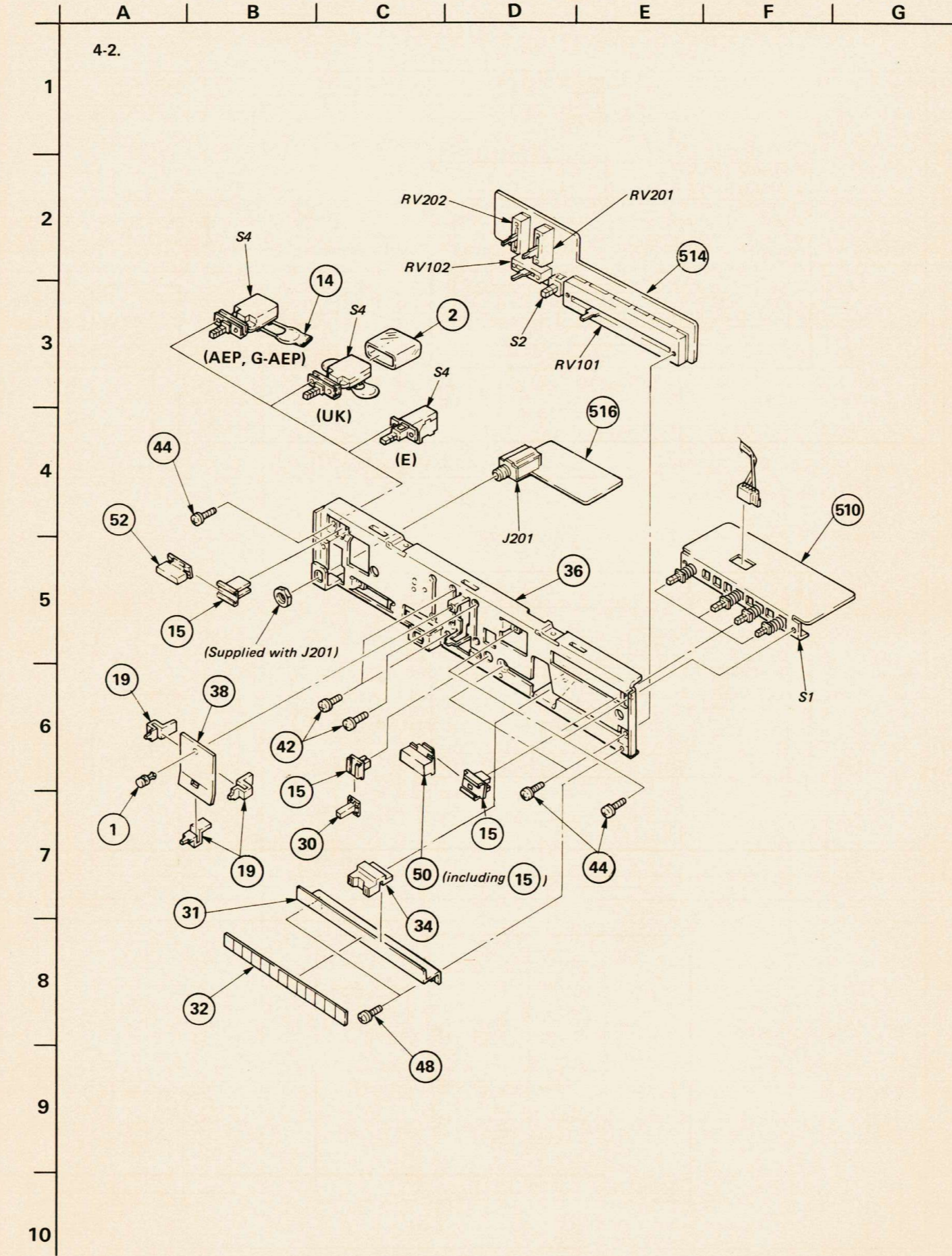
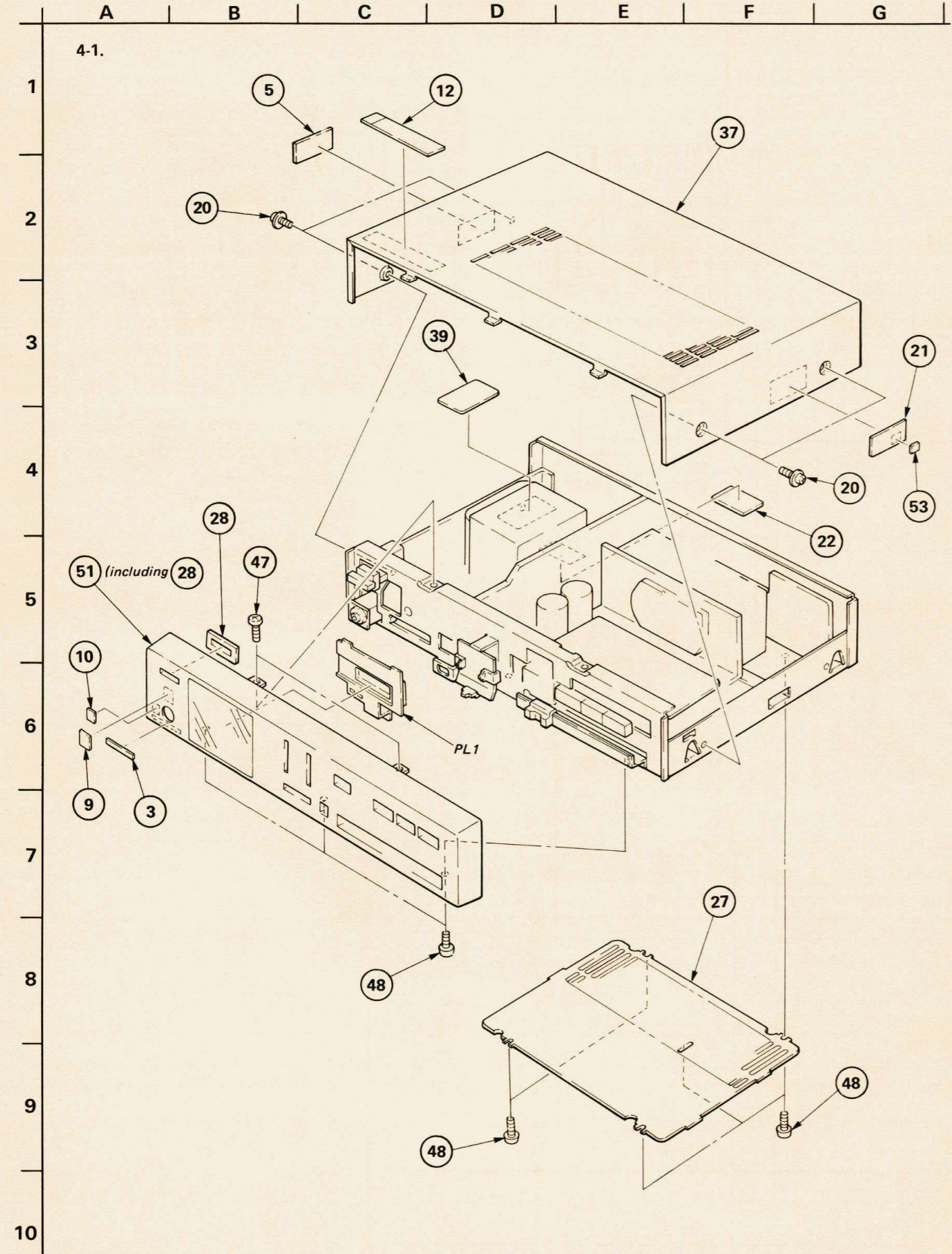

GENERAL SECTION

No.	Part No.	Description
1	3-531-576-01	RIVET
2	3-559-001-00	(UK)...COVER, POWER SWITCH
3	♣;3-701-690-00	(UK).....LABEL (MADE IN JAPAN)
4	3-701-993-00	SPACER, TERMINAL
5	3-703-043-00	(UK).....LABEL, CAUTION, MAIN
6	3-703-244-00	BUSHING, CORD
7	♣;3-703-353-05	SUPPORT, PC BOARD
8	3-703-473-00	SCREW, TERMINAL
9	3-703-710-01	(UK,AEP,G-AEP)...STICKER, SONY SYMBOL (12)
10	3-703-713-01	STICKER, SONY SYMBOL (10)
11	♣;3-706-165-00	SCREW
12	4-861-045-00	LABEL, CAUTION
13	4-869-217-00	CLIP, CORD
14	4-875-455-01	(AEP,G-AEP)...COVER (DIA. 20), CAPACITOR
15	4-875-466-00	JOINT (F2), KNOB
16	
17	♣;4-881-415-00	HEAT SINK (A)
18	♣;4-881-629-00	PLATE (A), GROUND
19	4-886-818-01	KNOB, SLIDE CONTROL
20	4-886-821-11	SCREW, M3 CASE
21	4-886-857-00	(AEP,G-AEP)...LABEL, MODEL NUMBER
22	4-886-858-00	(UK).....LABEL, MODEL NUMBER
22	4-886-859-00	(E).....LABEL, MODEL NUMBER
23	
24	♣;4-886-861-21	(AEP,G-AEP)...PANEL, REAR
24	♣;4-886-861-31	(UK).....PANEL, REAR
24	♣;4-886-861-41	(E).....PANEL, REAR
25	
26	
27	♣;4-886-894-11	PLATE, BOTTOM
28	4-886-976-00	ESCUTCHEON, POWER KNOB
29	♣;4-888-022-00	HOLDER, HEAT SINK
30	4-888-025-00	KNOB (D), PUSH
31	♣;4-888-027-00	GUIDE, CONTROL
32	4-888-029-00	ORNAMENT, CONTROL
33	♣;4-888-030-00	REINFORCEMENT
34	4-888-031-00	KNOB, CONTROL, SLIDE
35	♣;4-888-032-00	BASE, TRANSFORMER
36	♣;4-888-034-00	PANEL, SUB
37	4-888-035-00	CASE
38	♣;4-888-040-00	PLATE (A), BACK, CONTROL
39	4-888-041-00	CUSHION, TRANSFORMER
40	
41	♣;4-888-214-11	CHASSIS
42	7-621-255-35	SCREW +P 2X5
43	7-623-508-01	LUG, 3

NOTE:

- Items with no part number and no description are not stocked because they are seldom required for routine service.
- Items marked "♣" are not stocked since they are seldom required for routine service. Some delay should be anticipated when ordering these items.
- Due to standardization, parts with part numbers (Δ-ΔΔΔ-ΔΔΔ-XX or Δ-ΔΔΔΔ-ΔΔΔ-X) may be different from those used in the set.

CAPACITORS:

- All capacitors are in μF . Common capacitors are omitted. Refer to the following lists for their part numbers.
MF: μF , PF: $\mu\mu\text{F}$.

RESISTORS

- All resistors are in ohms. Common 1/4W, 1/8W and 1/16W carbon resistors are omitted. Refer to the following lists for their part numbers.

- F : nonflammable

COILS

- MMH : mH, UH : μH

GENERAL SECTION

No.	Part No.	Description
44	7-682-647-01	SCREW +PS 3X6
45	7-685-646-71	SCREW +BVTP 3X8 TYPE2 IT-3
46	7-685-650-71	SCREW +BVTP 3X16 TYPE2 IT-3
47	7-685-751-09	SCREW +PTT 3X6 (S)
48	7-685-871-01	SCREW +BVTT 3X6 (S)
49	X-4886-405-1	FOOT ASSY
50	X-4886-809-0	KNOB ASSY, PUSH
51	X-4886-810-1	FRONT PANEL ASSY
52	X-4886-903-0	KNOB (L.S) ASSY, POWER
53	3-703-591-02	(G-AEP)....LABEL (235855)(SMALL), FTZ

ACCESSORY & PACKING MATERIAL

No.	Part No.	Description
101	3-701-630-00	BAG, POLYETHYLENE
102	3-773-297-11	(AEP,UK,E)....MANUAL, INSTRUCTION
103	3-773-297-41	(AEP,G-AEP)....MANUAL, INSTRUCTION
104	4-855-809-00	SHEET, PROTECTION
105	4-888-012-00	CUSHION (RIGHT-E), UPPER
106	4-888-013-00	CUSHION (LEFT-E), UPPER
107	4-888-014-00	CUSHION (RIGHT-E), LOWER
108	4-888-015-00	CUSHION (LEFT-E), LOWER
109	4-888-021-00	INDIVIDUAL CARTON

The components identified by shading and mark Δ are critical for safety. Replace only with part number specified.

SEMICONDUCTORS

In each case, U : μ , for example:
UA...: μA ..., UPA...: μPA ..., UPC...: μPC ,
UPD...: μPD ...

ELECTRICAL PARTS

Ref.No.	Part No.	Description			
501	▲1-526-565-00	(E)...AC PLUG ADAPTOR			
502	▲1-533-131-00	HOLDER, FUSE			
▲503	▲1-535-139-00	BASE POST 19MM (10MM PITCH)			
▲504	▲1-535-140-00	BASE POST 19MM (10MM PITCH)			
▲505	▲1-535-416-00	(AEP,G-AEP)...TERMINAL			
506	1-535-466-00	PLATE, JUMPER			
507	▲1-551-472-00	(E).....CORD, POWER			
508	▲1-551-884-00	(UK).....CORD, POWER			
509	▲1-551-908-00	(AEP,G-AEP)...CORD, POWER, EULO PLUG			
510	1-609-805-00	PC BOARD, FUNCTION SW			
511	▲1-609-806-00	PC BOARD, INPUT & EQ			
512	▲1-609-808-00	PC BOARD, POWER IC			
▲513	▲1-609-809-00	PC BOARD, FUSE			
514	▲1-609-810-00	PC BOARD, CONTROL			
515	▲1-609-811-00	PC BOARD, SPEAKER TERMINAL			
516	▲1-609-829-00	PC BOARD, H.P JACK			
517	A-4388-337-A	(E).....MOUNTED PCB, POWER			
517	A-4388-338-A	(G-AEP).....MOUNTED PCB, POWER			
517	A-4388-344-A	(AEP,UK)....MOUNTED PCB, POWER			
C1	▲1-161-744-00	CAP, CERAMIC 10000PF	400V		
C2	▲1-161-744-00	(UK)...CAP, CERAMIC 10000PF	400V		
C101	1-161-320-00	CERAMIC 560PF	10%	50V	
C102	1-161-315-00	CERAMIC 220PF	10%	50V	
C103	1-161-315-00	CERAMIC 220PF	10%	50V	
C104	1-161-315-00	CERAMIC 220PF	10%	50V	
C105	1-123-354-00	ELECT 3.3MF	20%	50V	
C106	1-161-271-00	(AEP,UK,E)...CERAMIC 100PF	5%	50V	
C106	1-161-320-00	(G-AEP).....CERAMIC 560PF	5%	50V	
C107	1-161-269-00	CERAMIC 68PF	5%	50V	
C108	1-123-318-00	ELECT 33MF	20%	16V	
C109	1-108-573-00	MYLAR 0.0056MF	5%	50V	
C110	1-108-559-00	MYLAR 0.0015MF	5%	50V	
C111	1-123-609-00	ELECT 0.33MF	20%	50V	
C112	1-123-318-00	ELECT 33MF	20%	16V	
C113	1-130-621-00	FILM 0.012MF	5%	50V	
C151	1-161-320-00	CERAMIC 560PF	10%	50V	
C152	1-161-315-00	CERAMIC 220PF	10%	50V	
C153	1-161-315-00	CERAMIC 220PF	10%	50V	
C154	1-161-315-00	CERAMIC 220PF	10%	50V	
C155	1-123-354-00	ELECT 3.3MF	20%	50V	
C156	1-161-271-00	(AEP,UK,E)...CERAMIC 100PF	5%	50V	
C156	1-161-320-00	(G-AEP).....CERAMIC 560PF	5%	50V	
C157	1-161-269-00	CERAMIC 68PF	5%	50V	
C158	1-123-318-00	ELECT 33MF	20%	16V	
C159	1-108-573-00	MYLAR 0.0056MF	5%	50V	

ELECTRICAL PARTS

Ref.No.	Part No.	Description			
C160	1-108-559-00	MYLAR 0.0015MF	5%	50V	
C161	1-123-609-00	ELECT 0.33MF	20%	50V	
C162	1-123-318-00	ELECT 33MF	20%	16V	
C163	1-130-621-00	FILM 0.012MF	5%	50V	
C202	1-123-354-00	ELECT 3.3MF	20%	50V	
C203	1-161-315-00	CERAMIC 220PF	10%	50V	
C204	1-161-253-00	CERAMIC 3.3PF	10%	50V	
C205	1-123-359-00	ELECT 47MF	20%	35V	
C206	1-123-318-00	ELECT 33MF	20%	16V	
C207	1-130-624-00	FILM 0.022MF	5%	50V	
C208	1-108-567-00	MYLAR 0.0033MF	5%	50V	
C209	1-123-318-00	ELECT 33MF	20%	16V	
C210	1-161-269-00	CERAMIC 68PF	5%	50V	
C211	1-130-636-00	FILM 0.22MF	5%	50V	
C212	1-130-626-00	FILM 0.033MF	5%	50V	
C213	1-108-595-00	MYLAR 0.047MF	5%	50V	
C214	1-108-579-00	MYLAR 0.01MF	5%	50V	
C252	1-123-354-00	ELECT 3.3MF	20%	50V	
C253	1-161-315-00	CERAMIC 220PF	10%	50V	
C254	1-161-253-00	CERAMIC 3.3PF	10%	50V	
C255	1-123-359-00	ELECT 47MF	20%	35V	
C256	1-123-318-00	ELECT 33MF	20%	16V	
C257	1-130-624-00	FILM 0.022MF	5%	50V	
C258	1-108-567-00	MYLAR 0.0033MF	5%	50V	
C259	1-123-318-00	ELECT 33MF	20%	16V	
C260	1-161-269-00	CERAMIC 68PF	5%	50V	
C261	1-130-636-00	FILM 0.22MF	5%	50V	
C262	1-130-626-00	FILM 0.033MF	5%	50V	
C263	1-108-595-00	MYLAR 0.047MF	5%	50V	
C264	1-108-579-00	MYLAR 0.01MF	5%	50V	
C301	▲1-102-394-00	CERAMIC 0.01MFX2		250V	
C303	1-123-487-00	ELECT 470MF	20%	16V	
C304	▲1-124-362-00	ELECT 4700MF	20%	42V	
C305	▲1-124-362-00	ELECT 4700MF	20%	42V	
C306	1-123-484-00	ELECT 100MF	20%	16V	
C307	1-123-484-00	ELECT 100MF	20%	16V	
C308	1-123-380-00	ELECT 1MF	20%	50V	
C309	1-123-476-00	ELECT 330MF	20%	6.3V	
C310	1-123-341-00	ELECT 10MF	20%	35V	
C312	1-123-513-00	ELECT 100MF	20%	50V	
C313	1-108-595-00	MYLAR 0.047MF	5%	50V	
C314	▲1-161-326-00	CERAMIC 0.0022MF	30%	50V	
C315	▲1-161-326-00	CERAMIC 0.0022MF	30%	50V	
C316	▲1-101-002-21	CERAMIC 0.0022MF		50V	

NOTE:

- Items with no part number and no description are not stocked because they are seldom required for routine service.
- Items marked "▲" are not stocked since they are seldom required for routine service. Some delay should be anticipated when ordering these items.
- Due to standardization, parts with part numbers (Δ-ΔΔΔ-ΔΔΔ-XX or Δ-ΔΔΔ-ΔΔΔ-X) may be different from those used in the set.

CAPACITORS:

All capacitors are in μF. Common capacitors are omitted. Refer to the following lists for their part numbers. MF:μF, PF:μF.

RESISTORS

All resistors are in ohms. Common 1/4W, 1/8W and 1/16W carbon resistors are omitted. Refer to the following lists for their part numbers.

F : nonflammable

COILS

MMH : mH, UH : μH

The components identified by shading and mark ▲ are critical for safety. Replace only with part number specified.

SEMICONDUCTORS

In each case, U : μ, for example: UA...: μA..., UPA...: μPA..., UPC...: μPC, UPD...: μPD...

ELECTRICAL PARTS

Ref.No.	Part No.	Description
CN1	△.1-526-574-00	(E).....OUTLET, AC
CN1	△.1-526-694-00	(AEP,G-AEP)...OUTLET, AC
CN1	△.1-526-751-00	(UK).....OUTLET, AC
CNJ101	1-507-741-21	JACK, PIN 6P
CNJ102	1-507-740-00	JACK, PIN 4P
CNJ201	1-536-705-00	TERMINAL BOARD (SP)
D301	△.8-719-300-57	DIODE RB402
D302	△.8-719-521-10	DIODE S1VB10
D303	△.8-719-200-01	DIODE 10E-1
D304	8-719-901-61	DIODE HZ16-1L
D305	8-719-901-61	DIODE HZ16-1L
D306	8-719-815-55	DIODE 1S1555
D307	8-719-815-55	DIODE 1S1555
D309	8-719-815-55	DIODE 1S1555
D357	8-719-815-55	DIODE 1S1555
F1	△.1-532-078-00	FUSE, TIME LAG
F2	△.1-532-078-00	FUSE, TIME LAG
PL1	♣;1-518-530-00	INDICATOR, LAMP
IC101	8-759-935-58	IC TL4558P
IC201	8-749-946-30	IC STK-463
J201	1-507-689-00	JACK, LARGE TYPE
L201	♣;1-420-872-00	COIL, AIR CORE
L251	♣;1-420-872-00	COIL, AIR CORE
PS301	△.1-532-675-00	PROTECTOR, CIRCUIT
Q301	8-729-306-72	TRANSISTOR 2SD667A
Q302	8-729-364-72	TRANSISTOR 2SB647
Q303	8-729-606-32	TRANSISTOR 2SC2603
Q304	8-729-117-54	TRANSISTOR 2SA1175
Q305	8-729-606-32	TRANSISTOR 2SC2603
Q306	8-729-606-32	TRANSISTOR 2SC2603
Q309	8-729-612-77	TRANSISTOR 2SA1027R
Q359	8-729-612-77	TRANSISTOR 2SA1027R
R101	1-246-461-15	CARBON 330 5% 1/4W
R102	1-246-465-15	CARBON 470 5% 1/4W
R103	1-246-465-15	CARBON 470 5% 1/4W
R104	1-246-465-15	CARBON 470 5% 1/4W
R105	1-246-489-00	CARBON 4.7K 5% 1/4W
R106	1-246-513-00	CARBON 47K 5% 1/4W
R107	1-246-473-00	CARBON 1K 5% 1/4W
R108	1-246-539-00	CARBON 560K 5% 1/4W
R109	1-246-471-00	CARBON 820 5% 1/4W
R110	1-246-539-00	CARBON 560K 5% 1/4W
R111	1-246-513-00	CARBON 47K 5% 1/4W
R112	1-246-521-00	CARBON 100K 5% 1/4W

ELECTRICAL PARTS

Ref.No.	Part No.	Description
R113	1-246-473-00	CARBON 1K 5% 1/4W
R114	1-246-481-00	CARBON 2.2K 5% 1/4W
R115	1-246-517-00	CARBON 68K 5% 1/4W
R116	1-246-521-00	CARBON 100K 5% 1/4W
R151	1-246-461-15	CARBON 330 5% 1/4W
R152	1-246-465-15	CARBON 470 5% 1/4W
R153	1-246-465-15	CARBON 470 5% 1/4W
R154	1-246-465-15	CARBON 470 5% 1/4W
R155	1-246-489-00	CARBON 4.7K 5% 1/4W
R156	1-246-513-00	CARBON 47K 5% 1/4W
R157	1-246-473-00	CARBON 1K 5% 1/4W
R158	1-246-539-00	CARBON 560K 5% 1/4W
R159	1-246-471-00	CARBON 820 5% 1/4W
R160	1-246-539-00	CARBON 560K 5% 1/4W
R161	1-246-513-00	CARBON 47K 5% 1/4W
R162	1-246-521-00	CARBON 100K 5% 1/4W
R163	1-246-473-00	CARBON 1K 5% 1/4W
R164	1-246-481-00	CARBON 2.2K 5% 1/4W
R165	1-246-517-00	CARBON 68K 5% 1/4W
R166	1-246-521-00	CARBON 100K 5% 1/4W
R201	1-246-473-00	CARBON 1K 5% 1/4W
R202	1-246-515-00	CARBON 56K 5% 1/4W
R203	1-246-473-00	CARBON 1K 5% 1/4W
R204	1-246-474-00	CARBON 1.1K 5% 1/4W
R205	1-246-515-00	CARBON 56K 5% 1/4W
R206	1-246-471-00	CARBON 820 5% 1/4W
R207	1-246-493-00	CARBON 6.8K 5% 1/4W
R208	1-246-499-00	CARBON 12K 5% 1/4W
R209	1-246-530-00	CARBON 240K 5% 1/4W
R210	1-246-481-00	CARBON 2.2K 5% 1/4W
R211	1-246-503-00	CARBON 18K 5% 1/4W
R212	1-207-615-00	RES, METAL PLATE 0.33 2W
R213	1-244-885-00	CARBON 3.3K 5% 1/2W
R214	△.1-247-192-00	CARBON 10 5% 1/2W F
R215	△.1-247-192-00	CARBON 10 5% 1/2W F
R216	△.1-247-228-00	CARBON 330 5% 1/2W F
R251	1-246-473-00	CARBON 1K 5% 1/4W
R252	1-246-515-00	CARBON 56K 5% 1/4W
R253	1-246-473-00	CARBON 1K 5% 1/4W
R254	1-246-474-00	CARBON 1.1K 5% 1/4W
R255	1-246-515-00	CARBON 56K 5% 1/4W
R256	1-246-471-00	CARBON 820 5% 1/4W
R257	1-246-493-00	CARBON 6.8K 5% 1/4W
R258	1-246-499-00	CARBON 12K 5% 1/4W
R259	1-246-530-00	CARBON 240K 5% 1/4W

NOTE:

Items with no part number and no description are not stocked because they are seldom required for routine service.

Items marked "♣" are not stocked since they are seldom required for routine service. Some delay should be anticipated when ordering these items.

Due to standardization, parts with part numbers (△-△△△-△△△-XX or △-△△△-△△△-X) may be different from those used in the set.

CAPACITORS:

All capacitors are in μ F. Common capacitors are omitted. Refer to the following lists for their part numbers.
MF: μ F, PF: μ F.

RESISTORS

All resistors are in ohms. Common 1/4W, 1/8W and 1/16W carbon resistors are omitted. Refer to the following lists for their part numbers.

F: nonflammable

COILS

MMH: mH, UH: μ H

The components identified by shading and mark △ are critical for safety. Replace only with part number specified.

SEMICONDUCTORS

In each case, U: μ , for example:

UA...: μ A...; UPA...: μ PA...; UPC...: μ PC, UPD...: μ PD...

ELECTRICAL PARTS

Ref.No.	Part No.	Description
R260	1-246-481-00	CARBON 2.2K 5% 1/4W
R261	1-246-503-00	CARBON 18K 5% 1/4W
R262	1-207-615-00	RES, METAL PLATE 0.33 2W
R263	1-244-885-00	CARBON 3.3K 5% 1/2W
R264 Δ	1-247-192-00	CARBON 10 5% 1/2W F
R265 Δ	1-247-192-00	CARBON 10 5% 1/2W F
R266 Δ	1-247-228-00	CARBON 330 5% 1/2W F
R301	1-246-481-00	CARBON 2.2K 5% 1/4W
R302	1-246-481-00	CARBON 2.2K 5% 1/4W
R303	1-246-509-00	CARBON 33K 5% 1/4W
R304	1-246-533-00	CARBON 330K 5% 1/4W
R305	1-246-533-00	CARBON 330K 5% 1/4W
R306	1-246-535-00	CARBON 390K 5% 1/4W
R308	1-246-535-00	CARBON 390K 5% 1/4W
R311	1-246-493-00	CARBON 6.8K 5% 1/4W
R312	1-246-473-00	CARBON 1K 5% 1/4W
R313	1-246-509-00	CARBON 33K 5% 1/4W
R316 Δ	1-247-083-00	CARBON 10 5% 1/4W F
R317 Δ	1-247-083-00	CARBON 10 5% 1/4W F
R318 Δ	1-247-107-00	CARBON 100 5% 1/4W F
R319 Δ	1-247-224-00	CARBON 220 5% 1/2W F
R361	1-246-493-00	CARBON 6.8K 5% 1/4W
R362	1-246-473-00	CARBON 1K 5% 1/4W
R363	1-246-509-00	CARBON 33K 5% 1/4W
RV101	1-228-381-00	RES, VAR, SLIDE 250K
RV102	1-228-379-00	RES, VAR, SLIDE 250K
RV201	1-228-380-00	RES, VAR, SLIDE 100K
RV202	1-228-380-00	RES, VAR, SLIDE 100K
RY301	1-515-503-00	RELAY
S1	1-554-443-00	SWITCH, PUSH (4 KEY)
S2	1-554-444-00	SWITCH, PUSH (1 KEY)
S4 Δ	1-553-447-00	(AEP,G-AEP,UK)....SWITCH, POWER
S4 Δ	1-553-318-00	(E).....SWITCH, POWER
T1 Δ	1-447-553-00	(E).....TRANSFORMER, POWER
T1 Δ	1-447-554-00	(AEP,G-AEP,UK)....TRANSFORMER, POWER
VS1 Δ	1-526-576-31	(E).....SELECTOR, POWER VOLTAGE

NOTE:

- Items with no part number and no description are not stocked because they are seldom required for routine service.
- Items marked " Δ " are not stocked since they are seldom required for routine service. Some delay should be anticipated when ordering these items.
- Due to standardization, parts with part numbers (Δ - $\Delta\Delta\Delta$ - $\Delta\Delta\Delta$ -XX or Δ - $\Delta\Delta\Delta\Delta$ - $\Delta\Delta\Delta$ -X) may be different from those used in the set.

CAPACITORS:

- All capacitors are in μ F. Common capacitors are omitted. Refer to the following lists for their part numbers.
 MF: μ F, PF: μ F.

RESISTORS

- All resistors are in ohms. Common 1/4W, 1/8W and 1/16W carbon resistors are omitted. Refer to the following lists for their part numbers.

- F : nonflammable

COILS

- MMH : mH, UH : μ H

The components identified by shading and mark Δ are critical for safety. Replace only with part number specified.

SEMICONDUCTORS

- In each case, U : μ , for example:
 UA....: μ A...., UPA....: μ PA...., UPC....: μ PC, UPD....: μ PD....

Sony Corporation
 Consumer Products Group
 Technical Support Dept.