

Except for
USA and Canada

TC-252

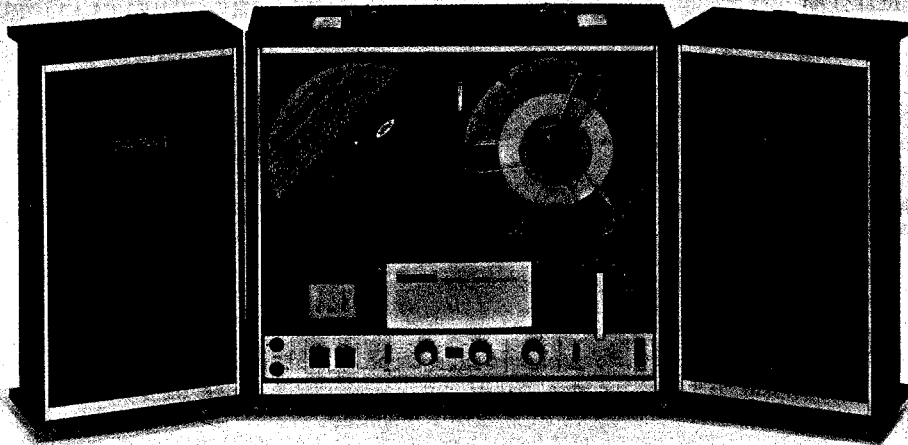

SPECIFICATIONS

Power Requirements: AC 50/60 Hz 100V, 110V, 117V,
125V, 220V & 240V 45W

Track System: Four-track stereo and mono

Reel Size: 7" (18 cm) maximum

Tape Speed: 7 $\frac{1}{2}$ ips, 3 $\frac{3}{4}$ ips and 1 $\frac{7}{8}$ ips
(19 cm/s, 9.5 cm/s and 4.8 cm/s)

Recording Time: (with 1,800 ft tape)	Tape speed	4-track stereo	4-track mono
	7 $\frac{1}{2}$ ips (19 cm/s)	1.5 hrs	3 hrs
	3 $\frac{3}{4}$ ips (9.5 cm/s)	3 hrs	6 hrs
	1 $\frac{7}{8}$ ips (4.8 cm/s)	6 hrs	12 hrs

Frequency Response: 30~18,000 Hz at 7 $\frac{1}{2}$ ips (19 cm/s)
30~13,000 Hz at 3 $\frac{3}{4}$ ips (9.5 cm/s)
30~ 7,000 Hz at 1 $\frac{7}{8}$ ips (4.8 cm/s)

Signal-to-Noise Ratio: 50 dB or more

Flutter and Wow: Less than 0.12% at 7 $\frac{1}{2}$ ips (19 cm/s)

Power Output: 4W maximum per channel

Recording Bias

Frequency: Approx. 85 kHz

Inputs: Two MIC inputs

Impedance : 600 Ω

Maximum sensitivity: 0.19 mV
(-72dB)

Two AUX Inputs

Impedance : 100k Ω

Maximum sensitivity: 60mV
(-72 dB)

REC/PB connector

Impedance : 10k Ω

Maximum sensitivity: 4.8mV
(-44 dB)

Outputs: Two LINE OUTPUTs

Impedance : 100 k Ω

Output level : 0.39V (-6 dB)

REC/PB connector

Impedance : 1 k Ω

Output level : 0.775V (0 dB)

Two SPEAKER outputs

Impedance : 8 Ω load

Output level : 2.7V (+11 dB)

PHONE output

Impedance : 8 Ω load

Output level : 30 mV (-28dB)

Speaker: Two 5" (130 mm) dynamic speakers

Voice coil impedance : 8 Ω

Semiconductors: 20 transistors and 3 diodes

Dimensions: 16 $\frac{1}{16}$ (W) x 10 $\frac{1}{8}$ (H) x 15" (D)

(408 x 256 x 380 mm)

Weight: 29lb 11oz (13.5kg)

SONY[®]
SERVICE MANUAL

TABLE OF CONTENTS

	Page		Page
SPECIFICATIONS	1	Component side	12
1. GENERAL DESCRIPTION	2	Preamp., power amp., bias osc. & power supply boards	
2. BLOCK DIAGRAM	2	Conductor side	13 ~ 14
3. CABINET TOP VIEW	3	Component side	15 ~ 16
4. CABINET BACK VIEW	3	11. SCHEMATIC DIAGRAM	17 ~ 18
5. DISASSEMBLY	4	12. WIRING DIAGRAM	19 ~ 20
6. CHASSIS TOP VIEW	5	HARDWARE NOMENCLATURE	21
7. CHASSIS BOTTOM VIEW	5	13. EXPLODED VIEW	
8. MECHANICAL ADJUSTMENT	6 ~ 8	Packing	21
9. ELECTRICAL ADJUSTMENT	9 ~ 10	Cabinet-Top view-	22
10. MOUNTING DIAGRAM		Head deck-Top view-	23
SOS switch board		Control chassis-Top view-	24
Conductor side	12	Chassis-Top view-	25
Component side	12	Chassis-Bottom view-	26
Speaker switch board			
Conductor side	12		

1. GENERAL DESCRIPTION

The SONY Model TC-252 is a four-track stereophonic tape recorder which may be operated in either vertical or horizontal position. The all silicon transistor amplifier circuit is specially designed for low noise and low distortion performance and represents the latest techniques from SONY engineers.

Outstanding features:

Sound-on-sound recording - Material recorded on one channel may be re-recorded on the other channel while simultaneously adding new material from an outside source. The mixed product appears in composite recording on the second channel. A SOS switch is provided on the panel for this special technique, which may be performed from left to right channels or vice-versa.

Scrape Flutter Filter - - This is a roller which is located between the erase head and the record/playback head. It prevents the tape from developing longitudinal vibrations which can result in tape squeal or frequency modulated distortion of the tape movement across the heads.

Retractable Pinch Roller - - The pinch roller is automatically retracted when the recorder is placed in the stop mode. This simplifies tape threading greatly by opening the tape path.

2. BLOCK DIAGRAM

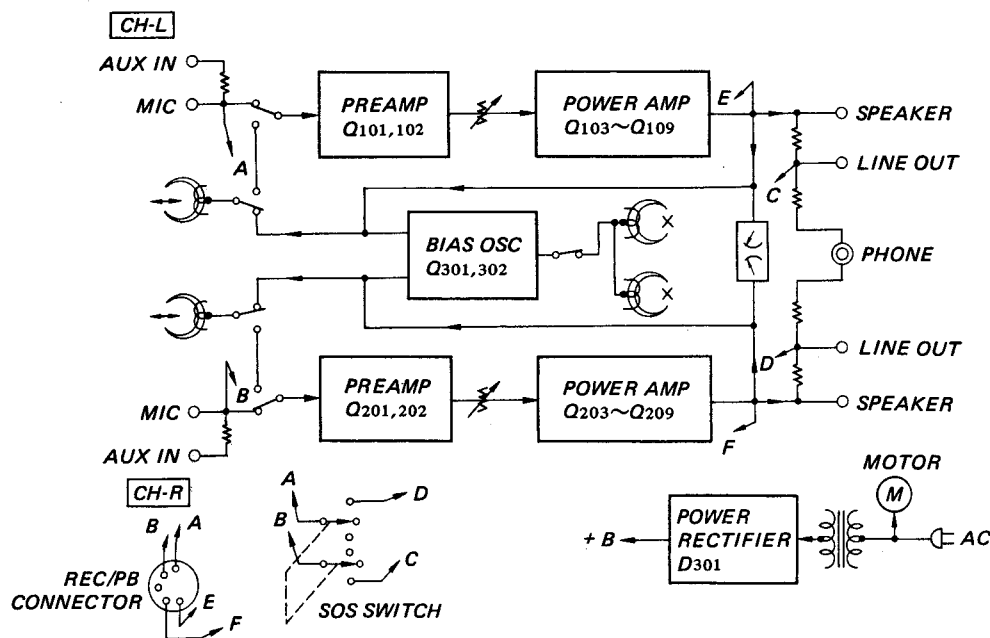

3. CABINET TOP VIEW

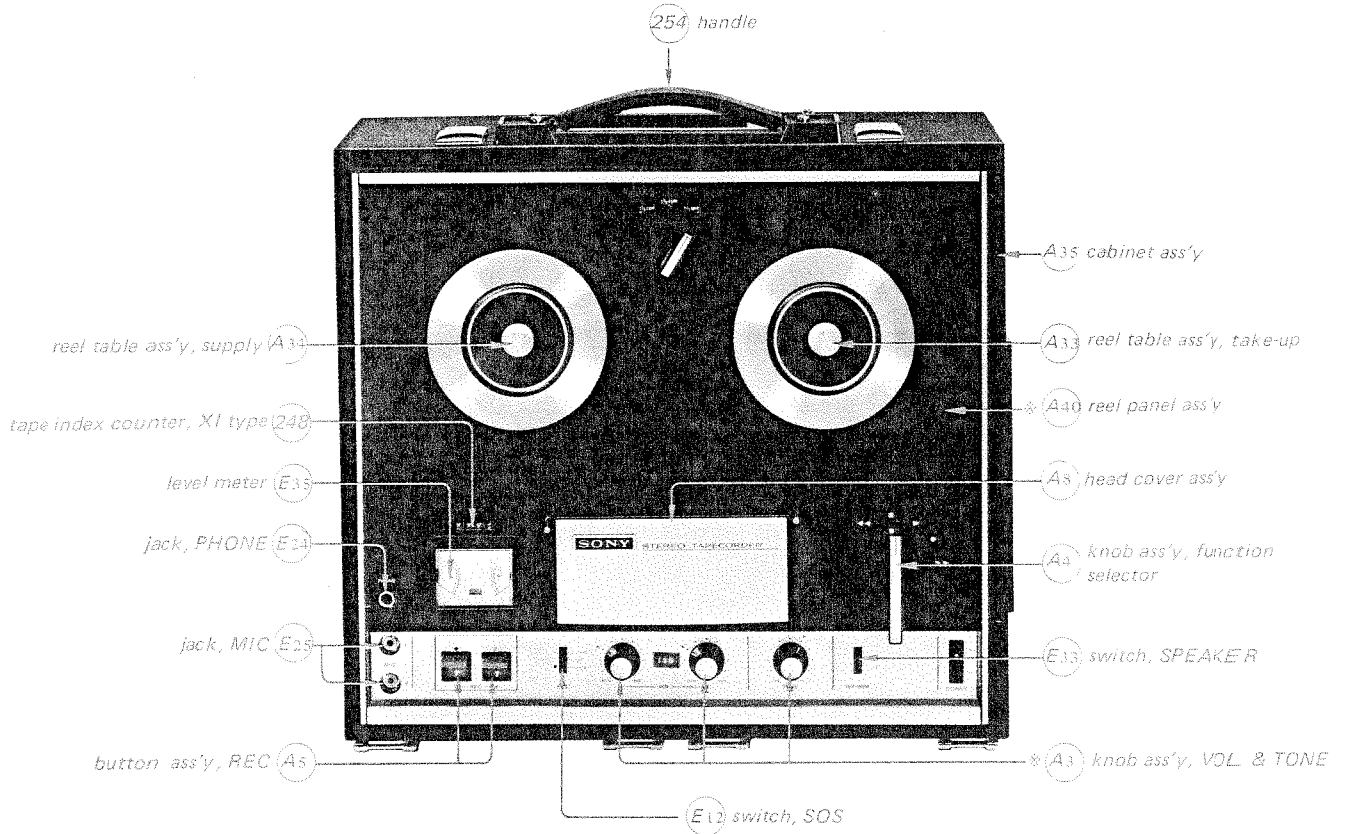

Ref. No.	Description	Serial No. up to 23,000		Serial No. 23,001 and later	
		Part No.	Color	Part No.	Color
* A3	Knob Ass'y	X-34600-03-1	black	X-34600-03-5	silver
* A40	Reel Panel Ass'y	X-34630-06-1	black	X-34630-06-2	white

4. CABINET BACK VIEW

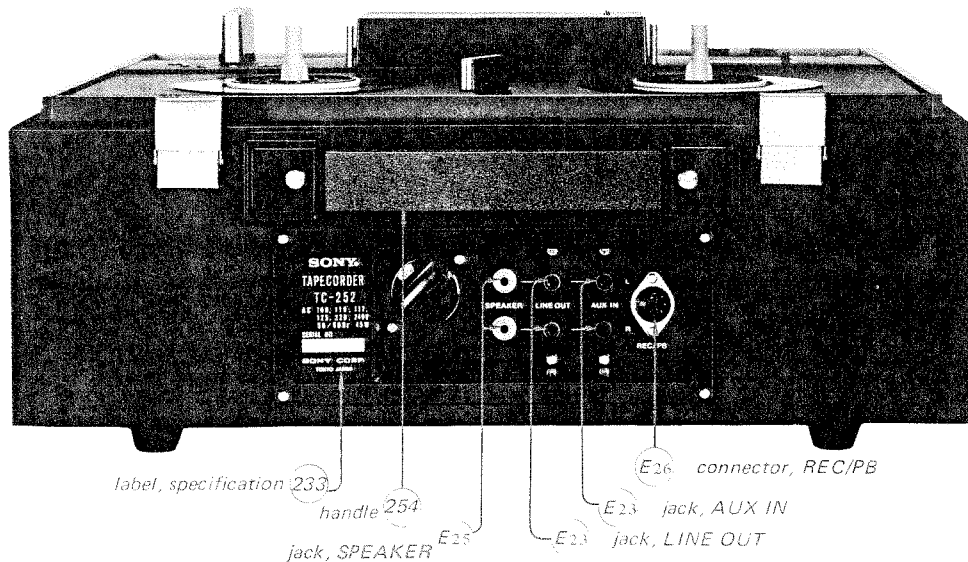

Reel panel removal

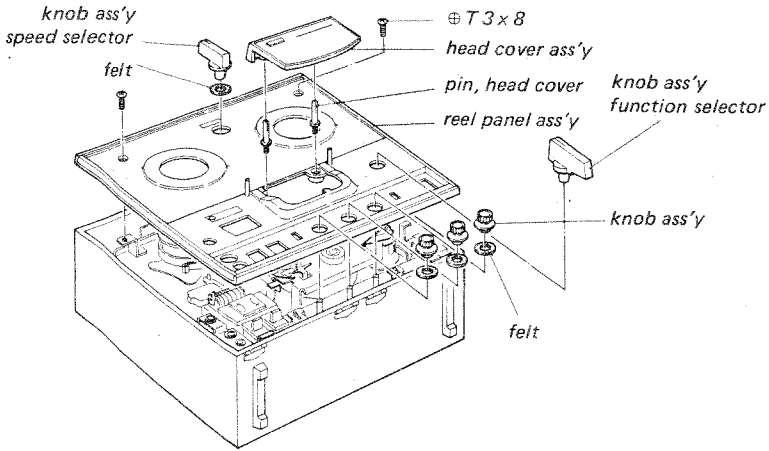

Chassis removal

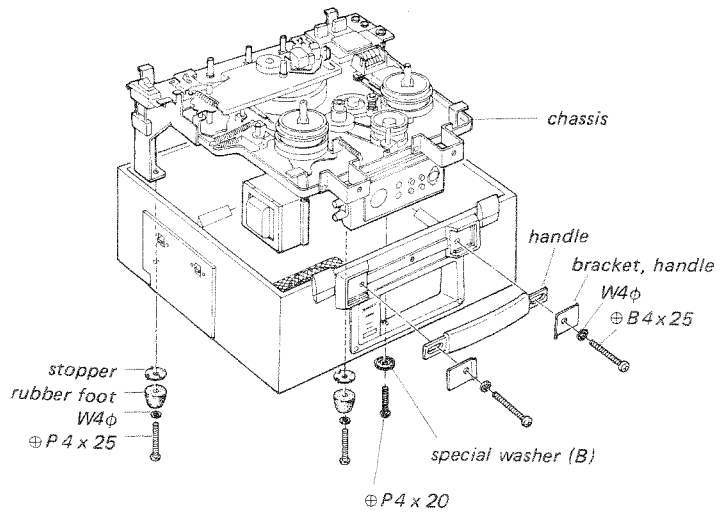

Circuit boards removal

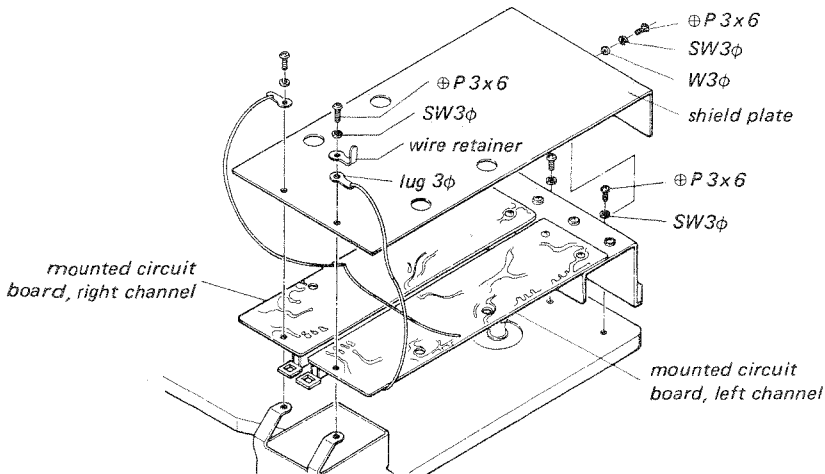

6. CHASSIS TOP VIEW

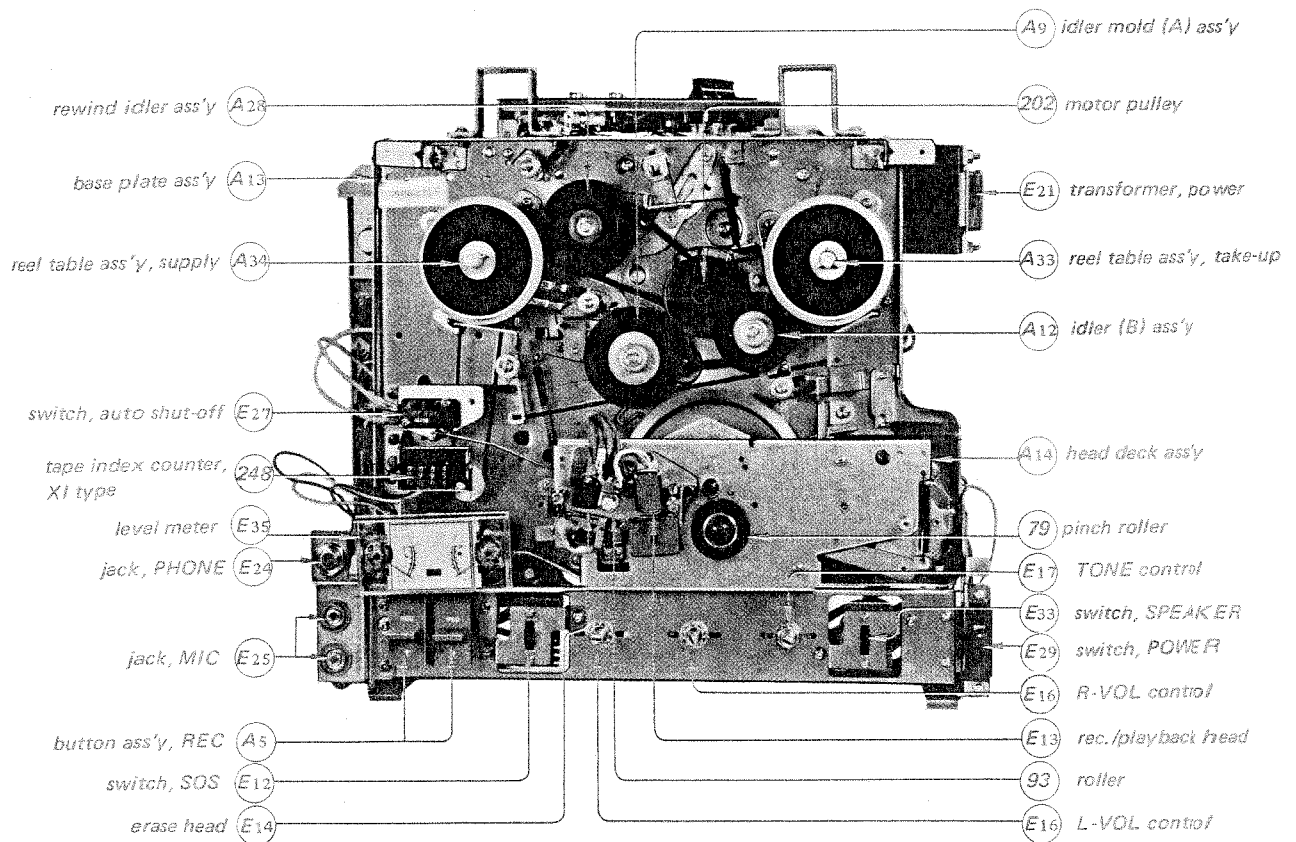

7. CHASSIS BOTTOM VIEW

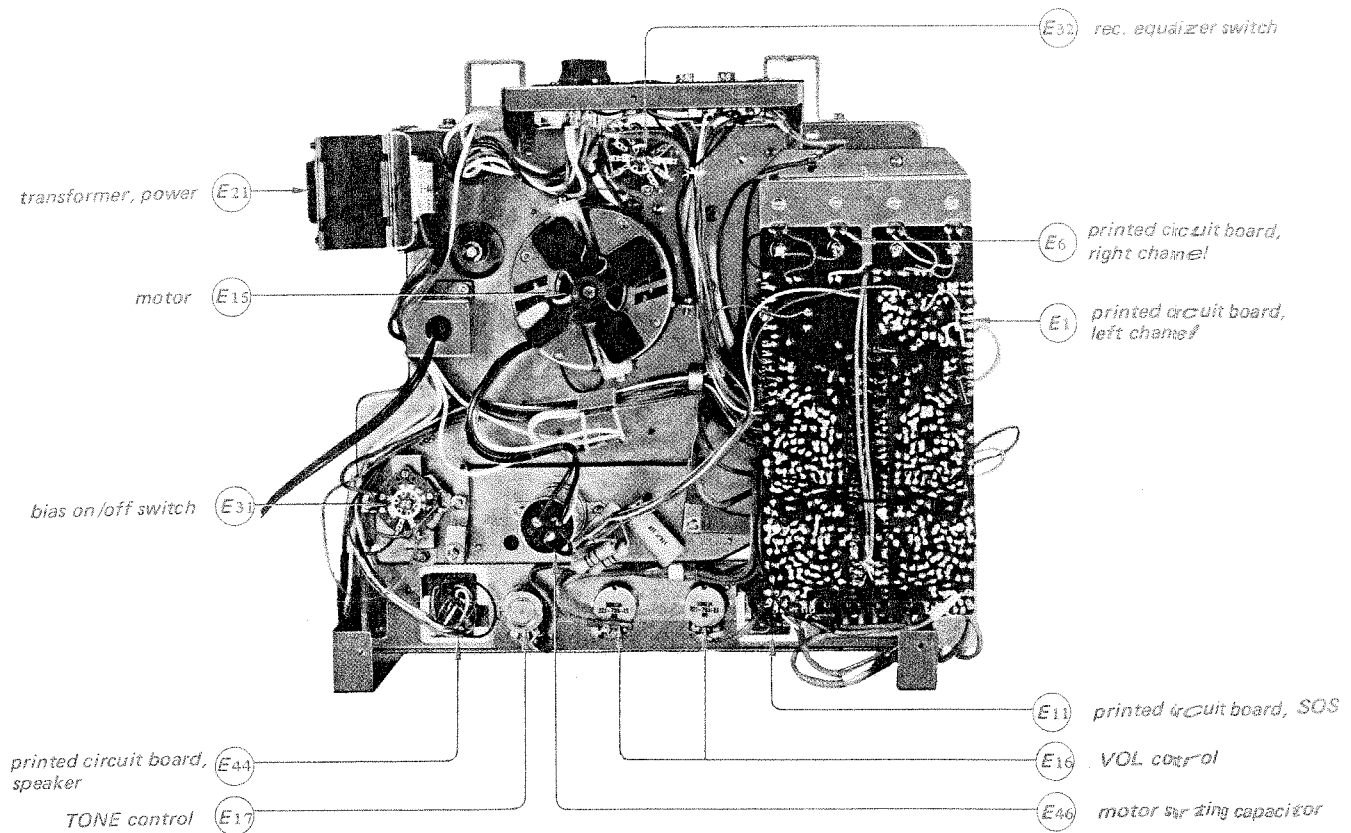

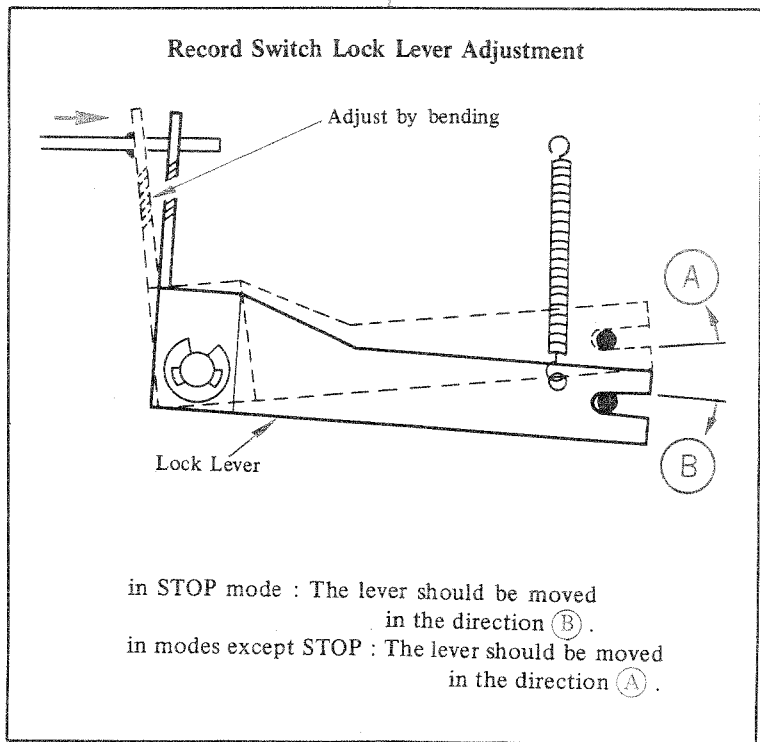
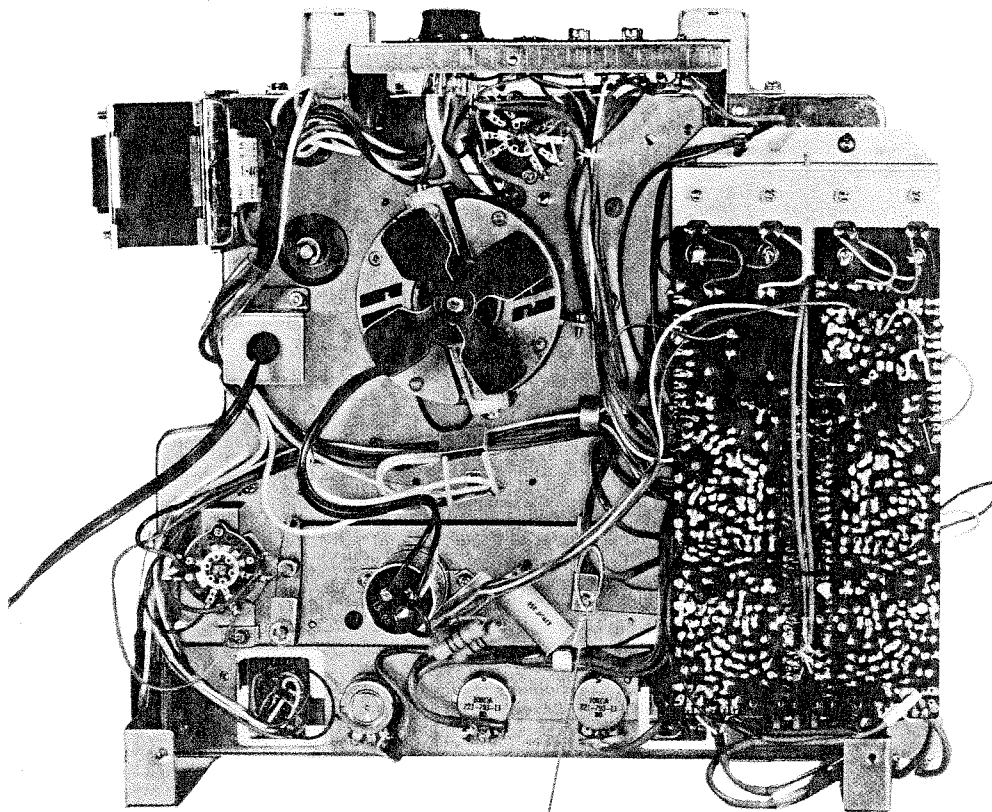

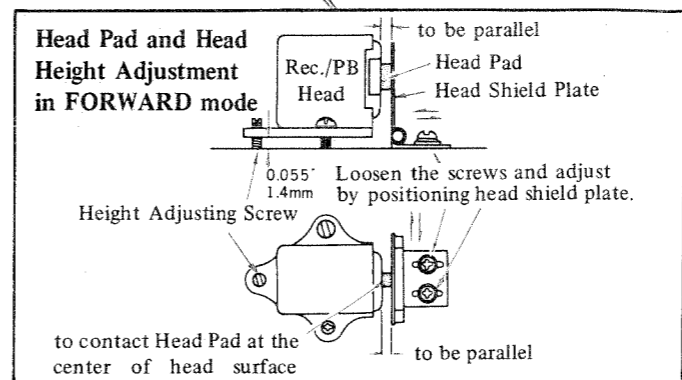
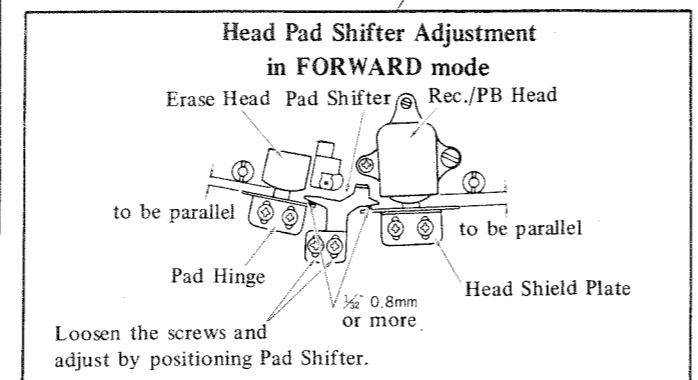
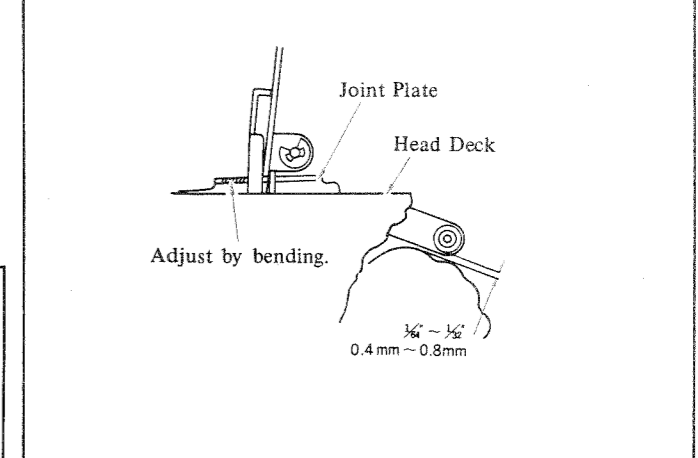
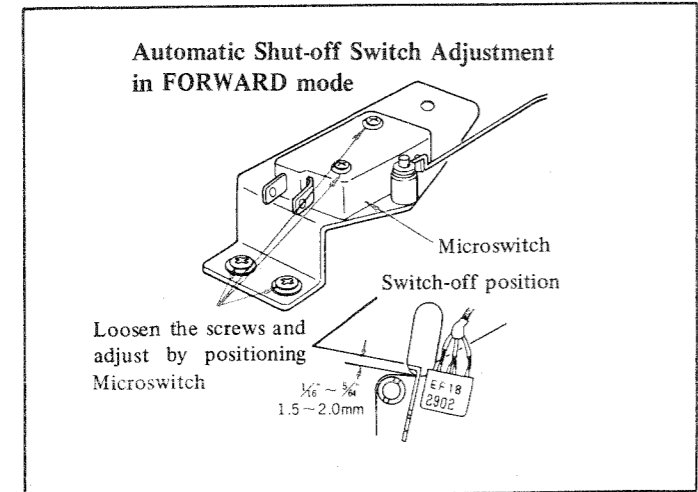
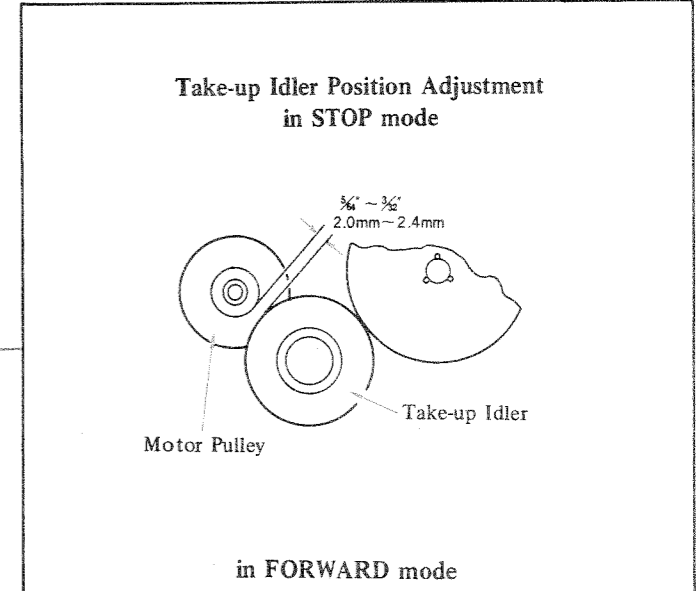
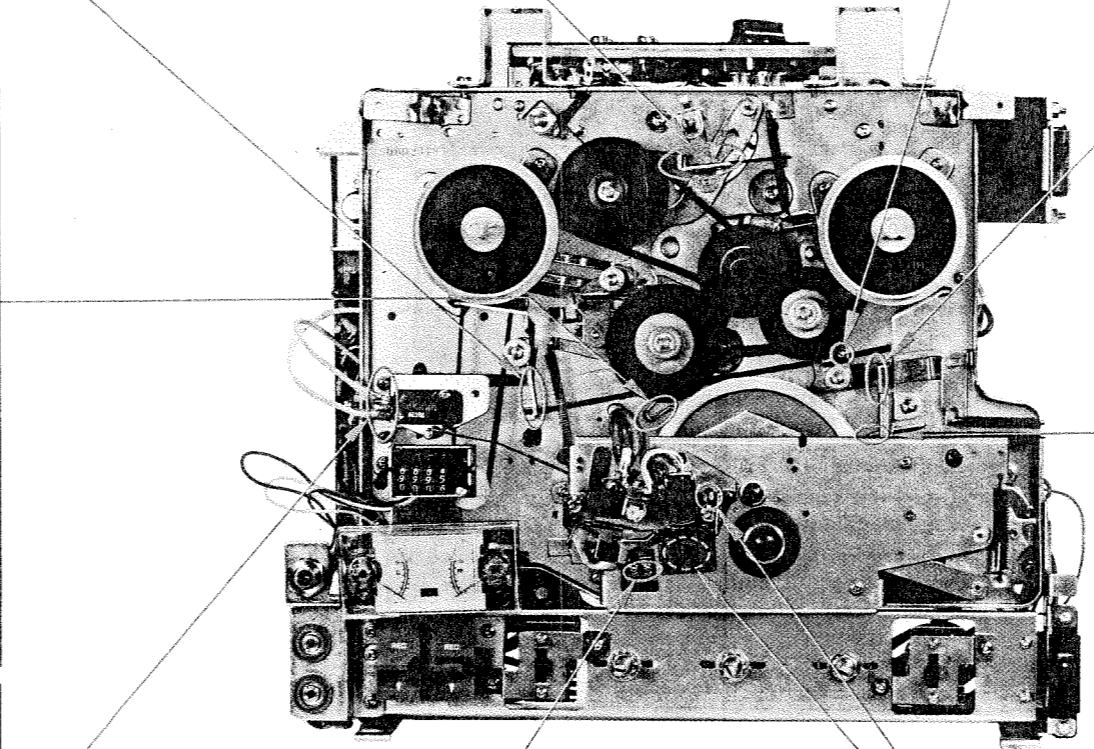
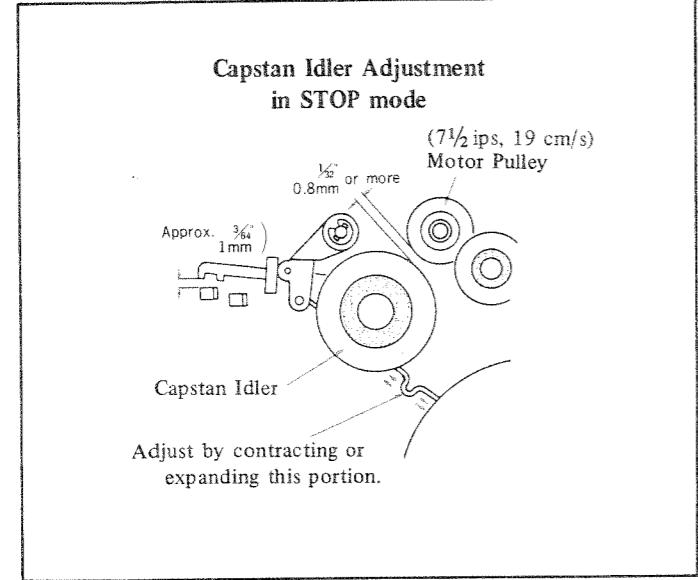
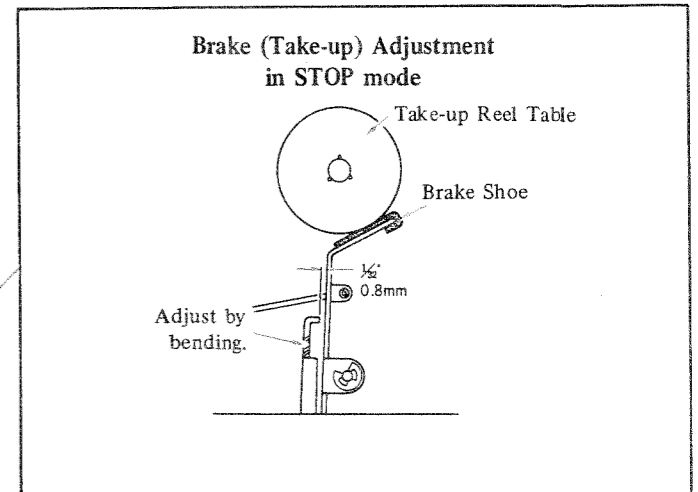
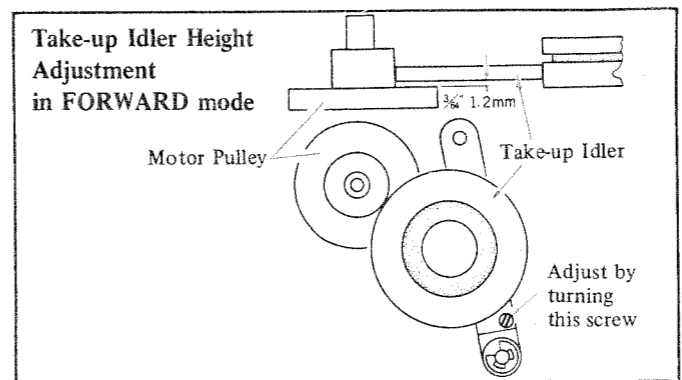
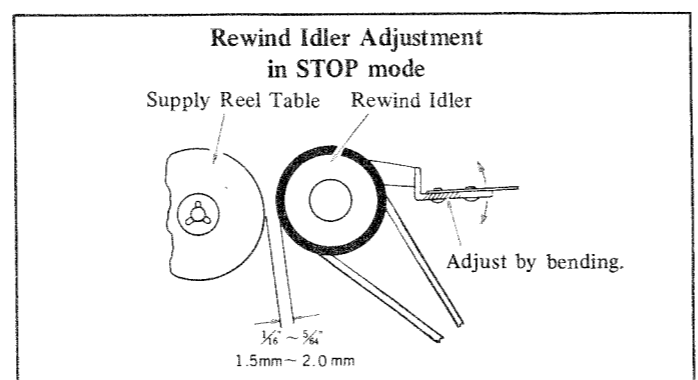
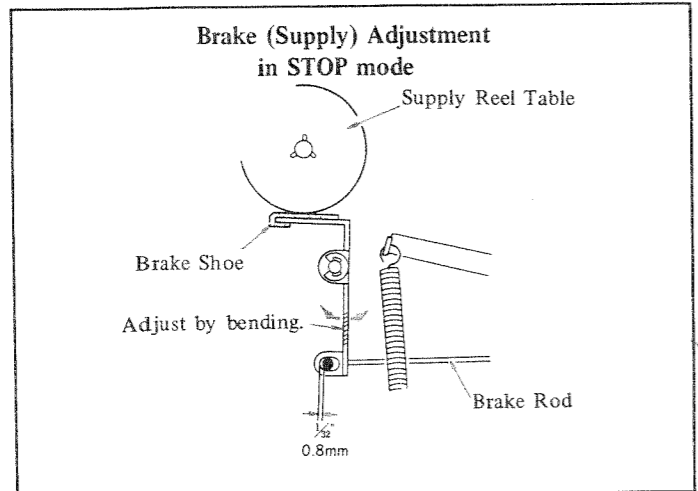

9 ELECTRICAL ADJUSTMENT

Item	Signal Source	Output Connection	Mode	Adjust	Remarks
1. Record/playback Head Azimuth Alignment	SONY Alignment Tape J-19-F 1, 1st tone, 10kHz (AMPEX Alignment Tape 01-31321-04, 2nd tone, 15 kHz) or equivalent	VTVM and 8Ω resistor in parallel with SPEAKER jack	playback	azimuth alignment screw See Fig. 1.	Adjust for maximum VTVM reading.
2. Bias Trap Adjustment	no signal	same as Item 1	playback and record	L101 (for CH-L) L201 (for CH-R) See Fig. 2.	1. Set CH-L (CH-R) VOL control to MAX and CH-R (CH-L) to MIN. 2. Place CH-L (CH-R) in playback mode and CH-R (CH-L) in record mode. 3. Adjust L101 (L201) for minimum VTVM reading on CH-L (CH-R).
3. Level Meter Calibration	1 kHz, -60 dB (78 μV) to MIC jack	same as Item 1	record	R145 (for CH-L) R245 (for CH-R) See Fig. 2.	1. Adjust CH-L (CH-R) VOL control to obtain 0 dB (0.775 V) on VTVM. 2. Adjust R145 (R245) so that the level meter indicates 100 on the scale.
4. Recording Bias Adjustment	no signal	VTVM across record/playback head	record	tap of bias osc. transformer T302 See Fig. 3.	Make sure that bias voltage across record/playback head is 20 V or more. See note 7 below. If not, change taps of osc. transformer T302.

- Note:
- Before making adjustments, be sure to clean heads with cloth or swab dampened with denatured alcohol and to demagnetize record/playback head with a head demagnetizer (SONY HE-2).
 - The adjustments should be made in numerical order.
 - The switches or controls should be set in the following positions:
SOS switch: OFF SPEAKER switch: 2 TONE control: HIGH
 - The adjustments should be made at 7½ ips (19 cm/s) tape speed.
 - After adjustment, apply lock paint to the parts adjusted.

- The following test equipment is to be used for the adjustments:
 - * Audio signal generator
 - * Resistor 8Ω 10W
 - * Attenuator 600Ω
 - * SONY Alignment Tape J-19-F1 (AMPEX Alignment Tape 01-31321-04) or equivalent.
 - * VTVM
- Bias voltage across heads should be read on VTVM as follows:
 - record/playback head: approx. 21 V
 - erase head: approx. 45 V

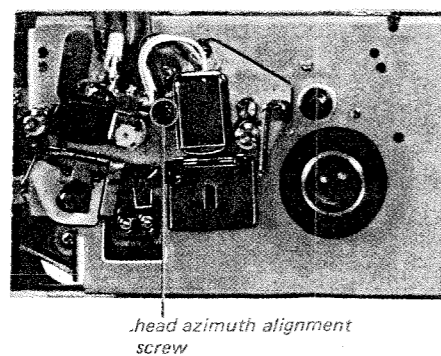

Fig. 1 Adjusting parts location for item 1

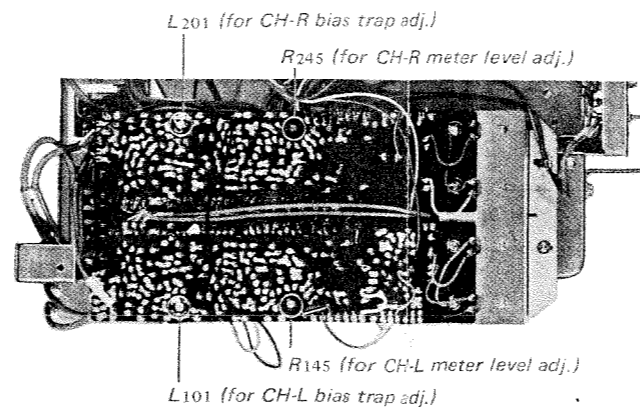
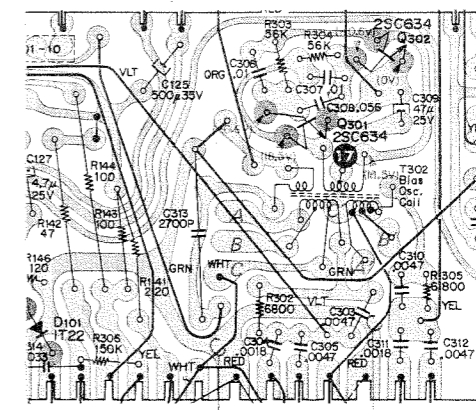

Fig. 2 Adjusting parts location for items 2 and 3



Change the lead connections to point A(A'), B(B') or C(C').

Fig. 3 Mounting diagram of bias osc. section

MEMO

SOS switch board P3

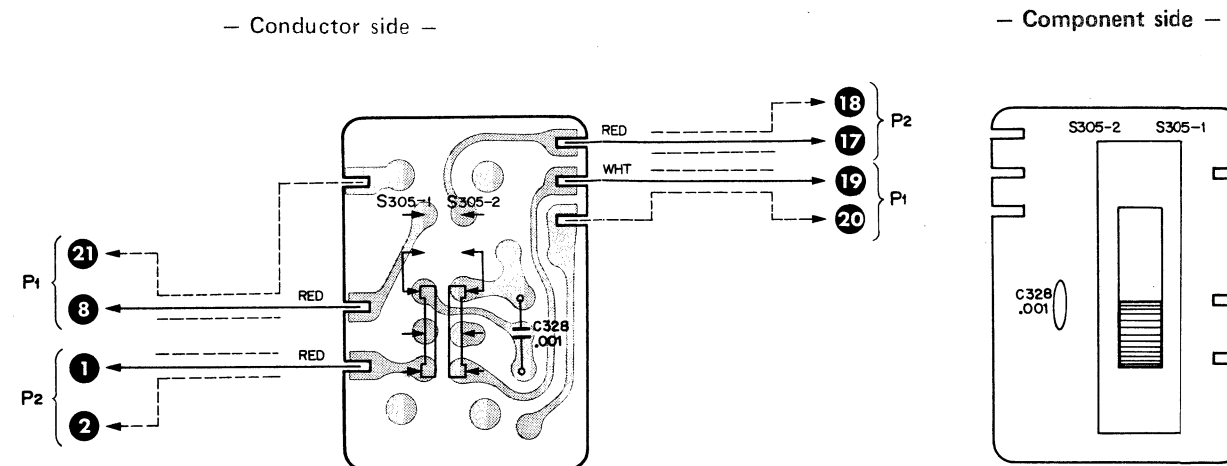

Speaker switch board P4

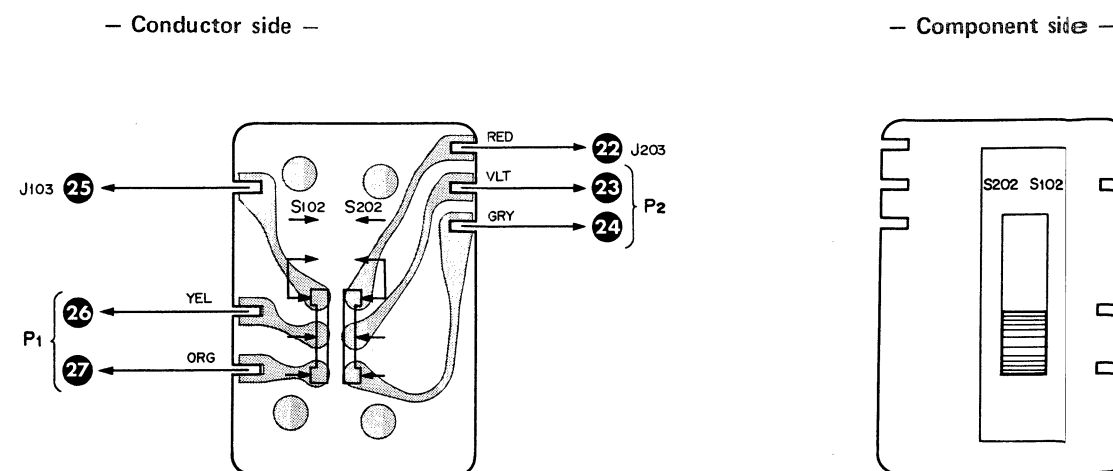

TC-252 TC-252

CH-L Preamp., Power Amp. & Bias Osc. board P1
 CH-R Preamp., Power Amp. & Power Supply board P2
 - Conductor side -

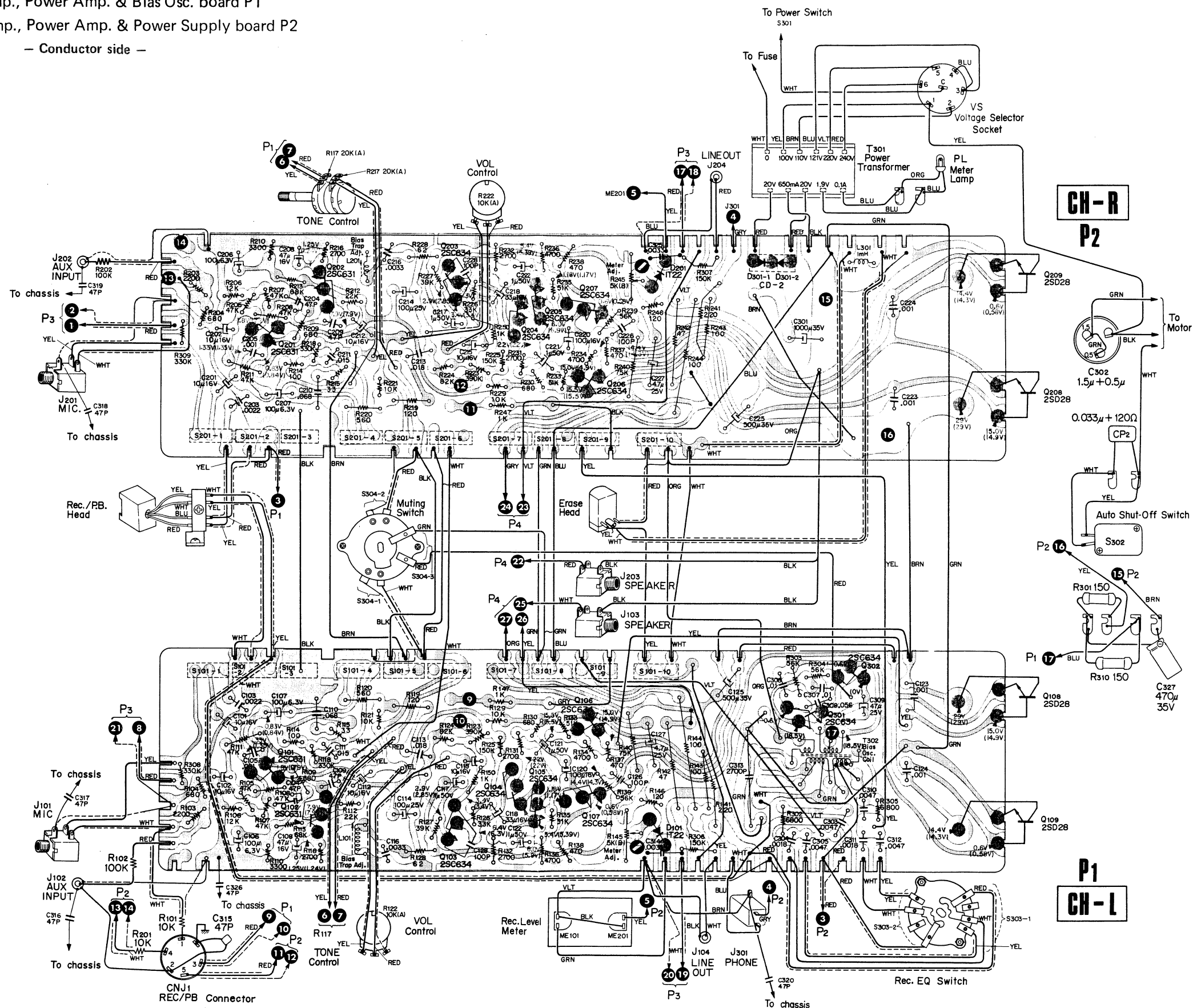

TC-252 TC-252

— Component side —

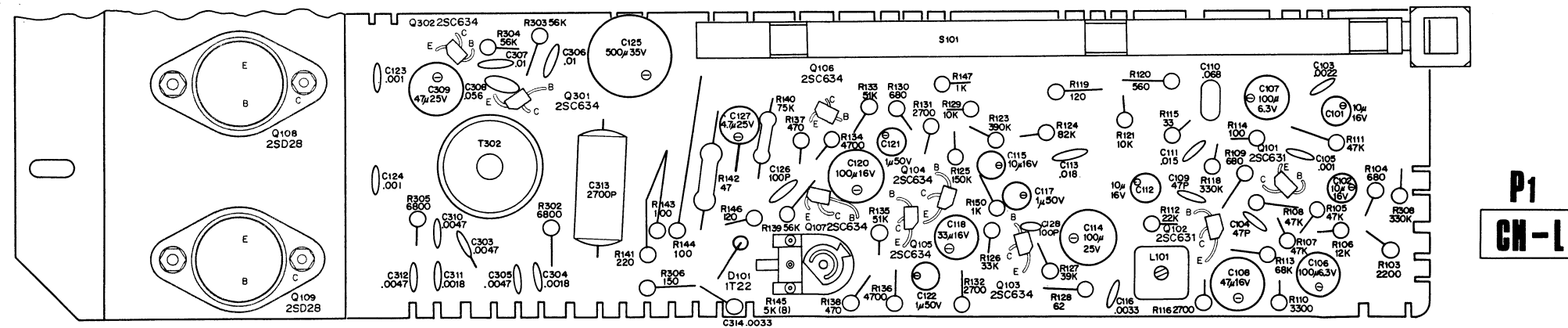
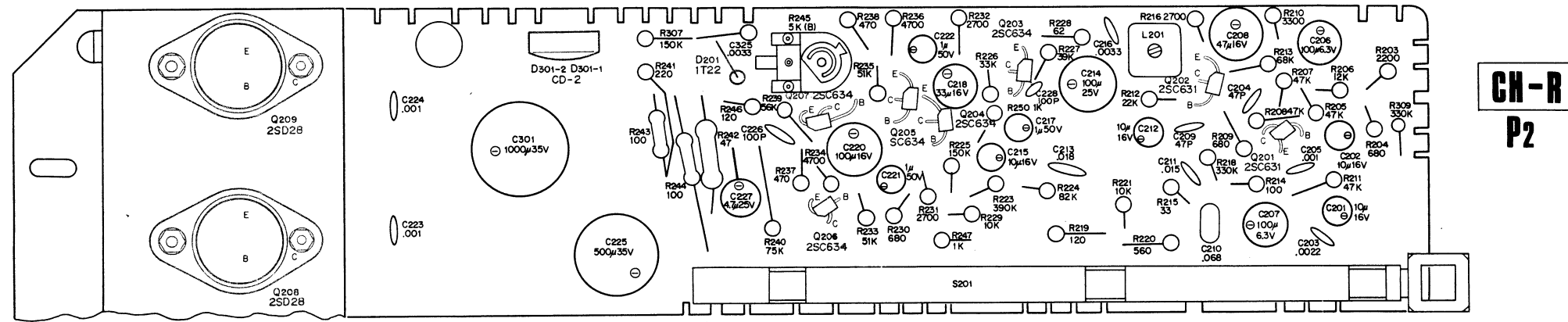

TC-252 TC-252

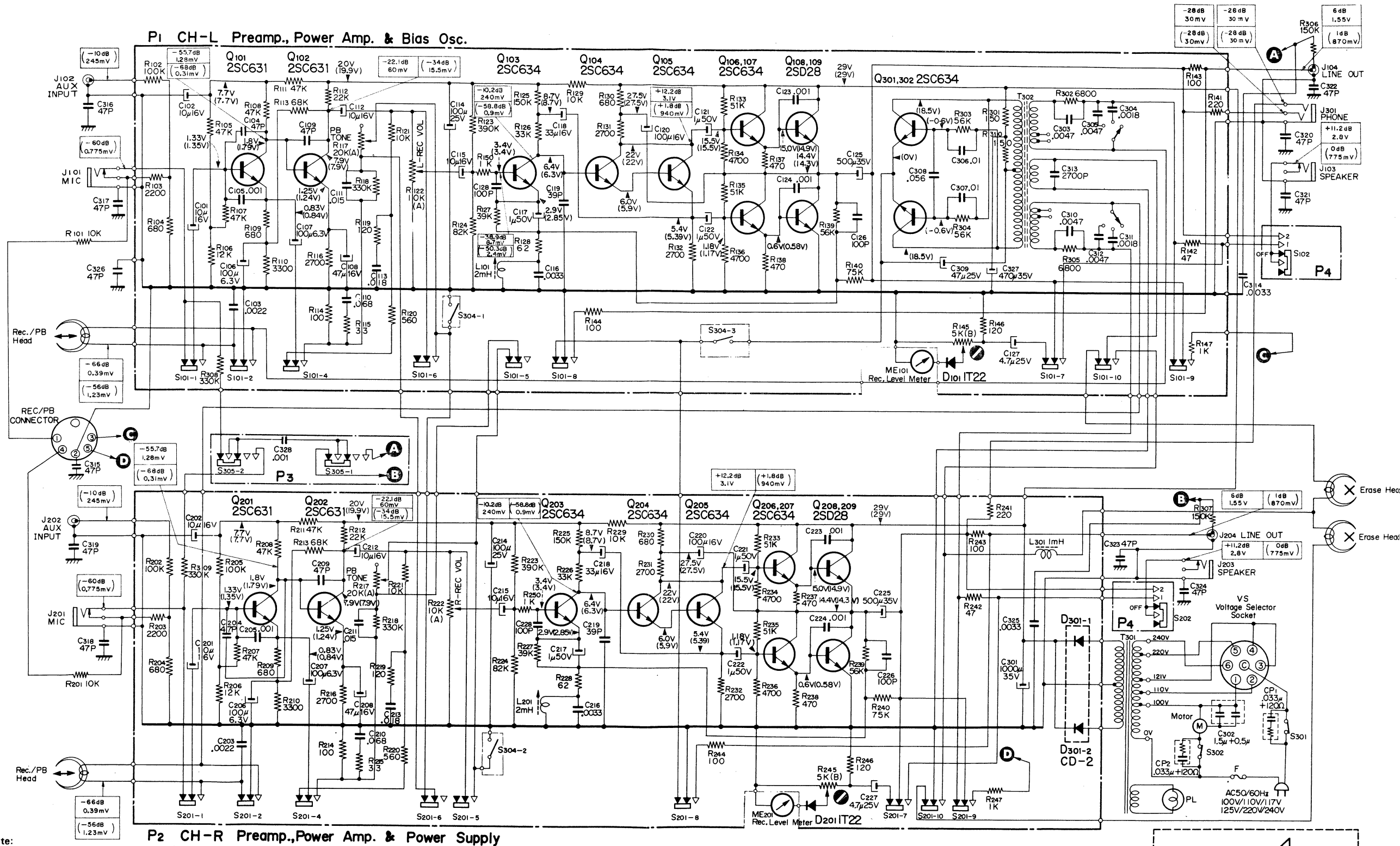

Note:

1. All resistors and capacitors are rated in Ω and μF unless otherwise specified.
2. \odot : adjustable
3. \perp : grounded to chassis
4. The letter (A) or (B) suffixed to rating value of potentiometer indicates its characteristics.
5. DC voltages shown in ORANGE color are measured to ground circuit with a VTVM. Values in () are taken in record mode. Variations may be noted due to normal production tolerances.
6. Signal levels shown in BLUE color are measured with a VTVM delivering 1 kHz input signal. Values in () are taken in record mode stopping bias oscillation. 0 dB=0.775V

Input and output connections when measuring levels are as follows:

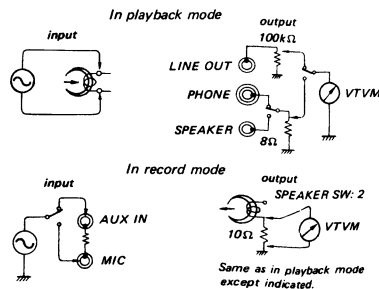

7. Switch positions are shown in the following table.

Symbol	Description	Position
S101, 201	Record/playback switch	record
S102, 202	SPEAKER switch	OFF
S301	POWER switch	ON
S302	Auto shut off switch	ON
S303	Record equalizer switch	7 1/2" 19 cm
S304-3	Bias osc. on/off switch	OFF
S304-1-2	Muting switch	OFF
S305	SOS switch	L → R

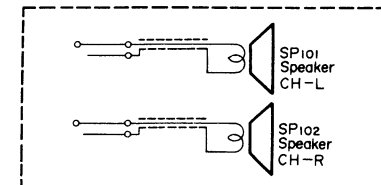

12. WIRING DIAGRAM

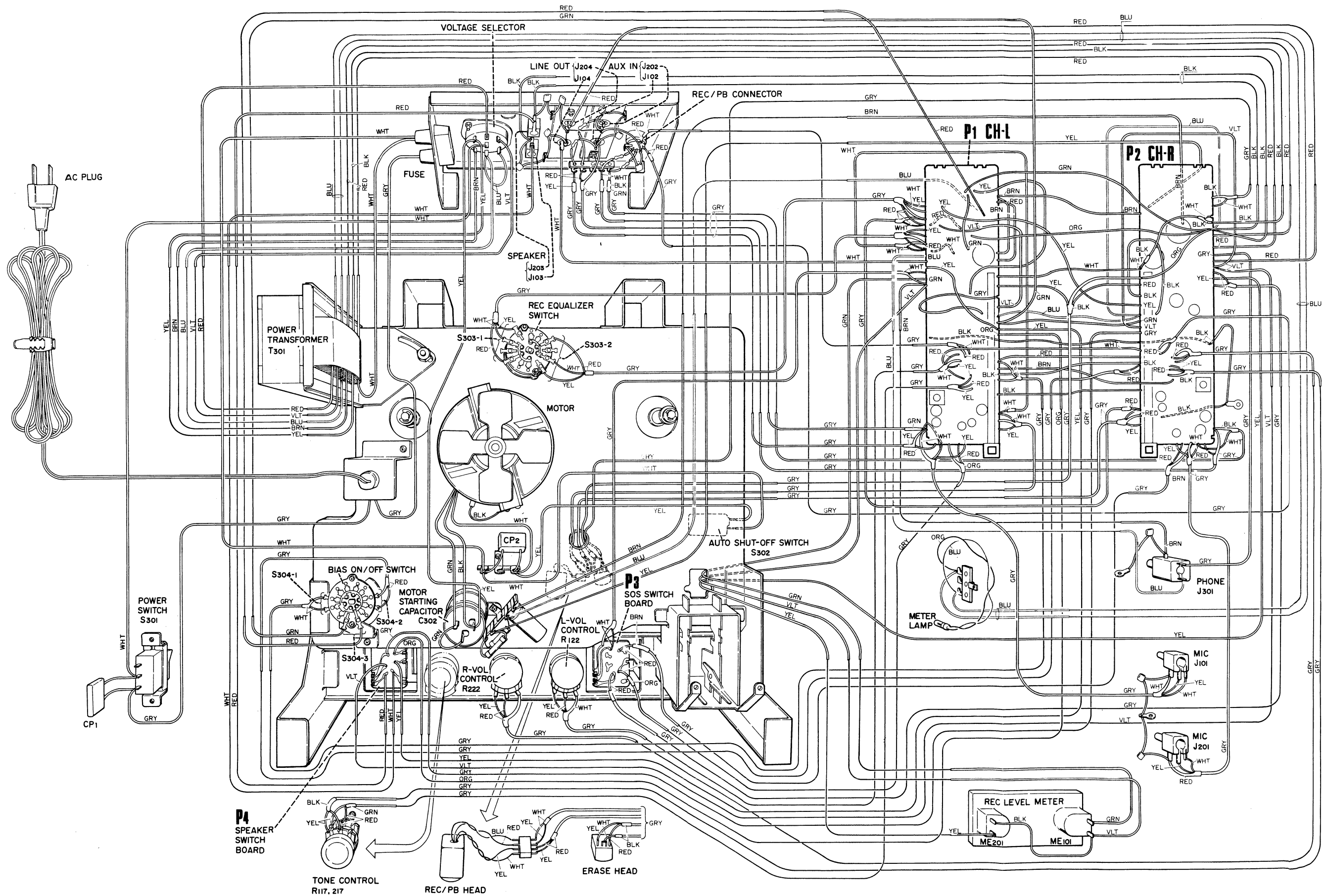

TC-252 TC-252

13. EXPLODED VIEW

Packing

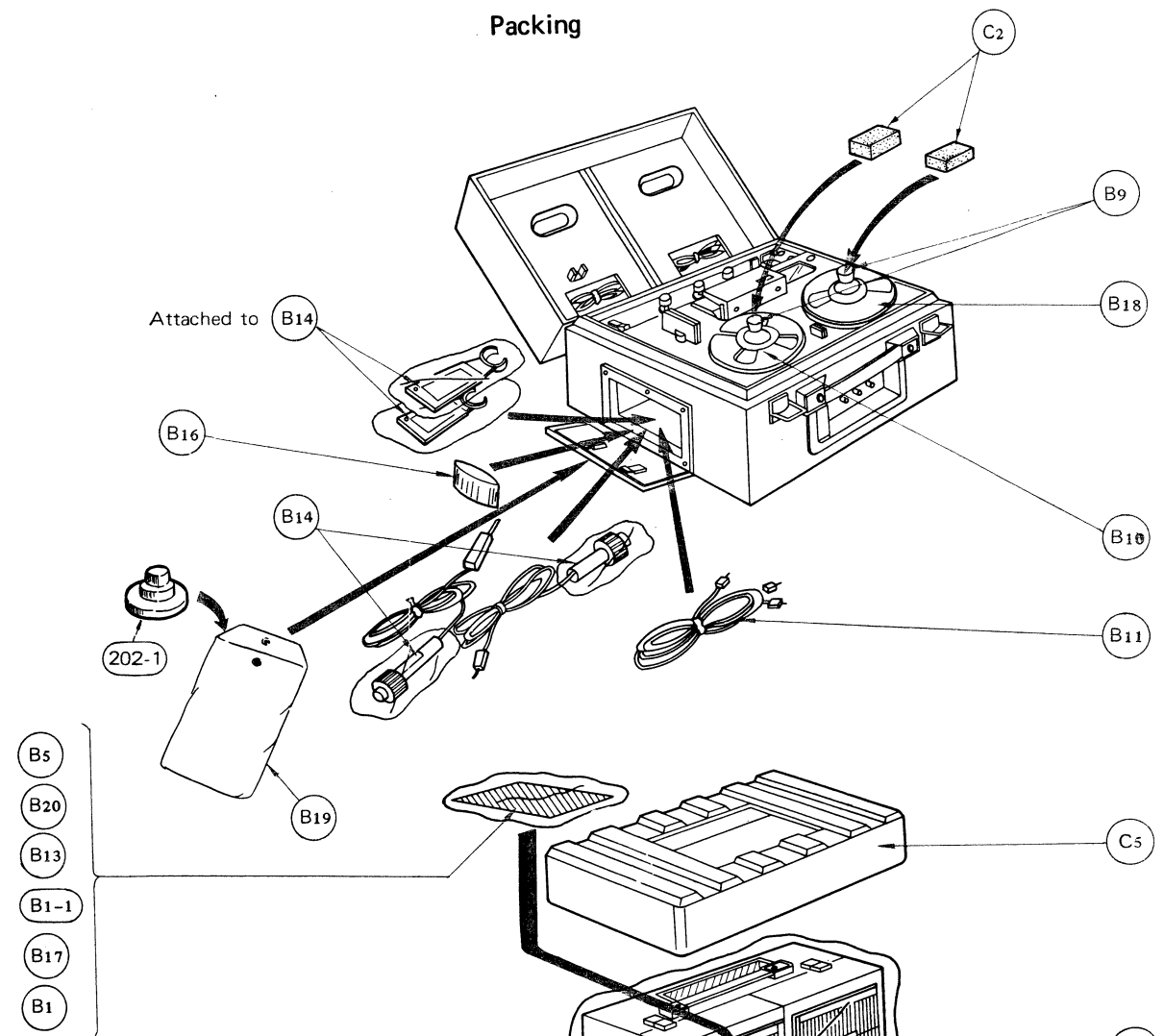

Hardware Nomenclature

P - Pan Head Screw	
K - Flat Countersunk Head Screw	
B - Binding Head Screw	
RK - Oval Countersunk Head Screw	
T - Truss Head Screw	
R - Round Head Screw	
F - Flat Fillister Head Screw	
SC - Set Screw	
E - Retaining Ring (E Washer)	
W - Washer SW - Spring Washer LW - Lock Washer N - Nut	

Example

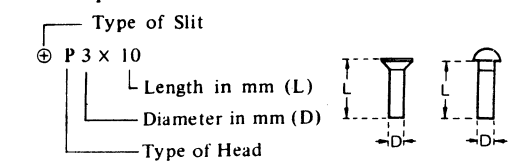

Cabinet - Top view -

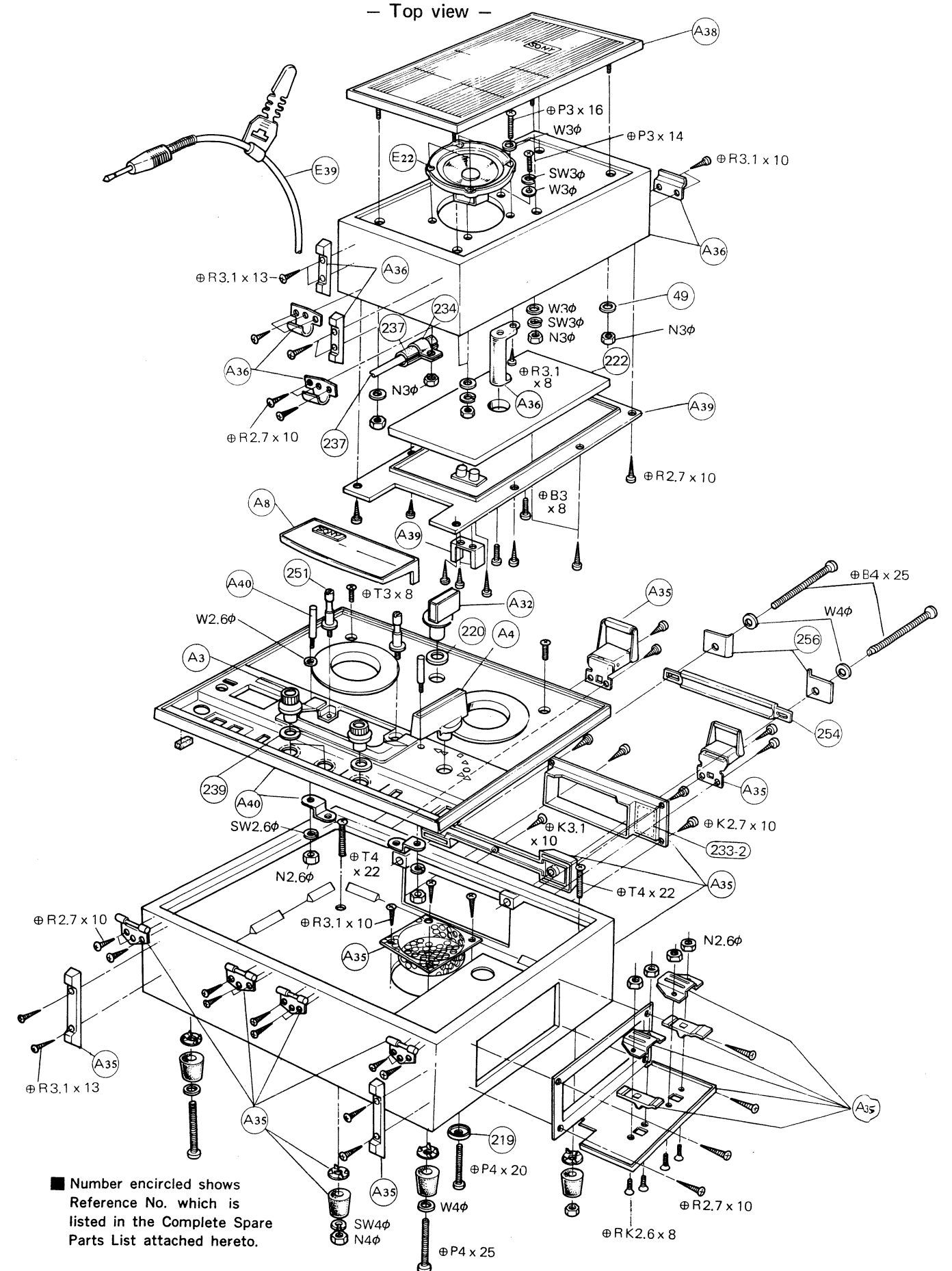

■ Number encircled shows Reference No. which is listed in the Complete Spare Parts List attached hereto.

Head deck
 — Top view —

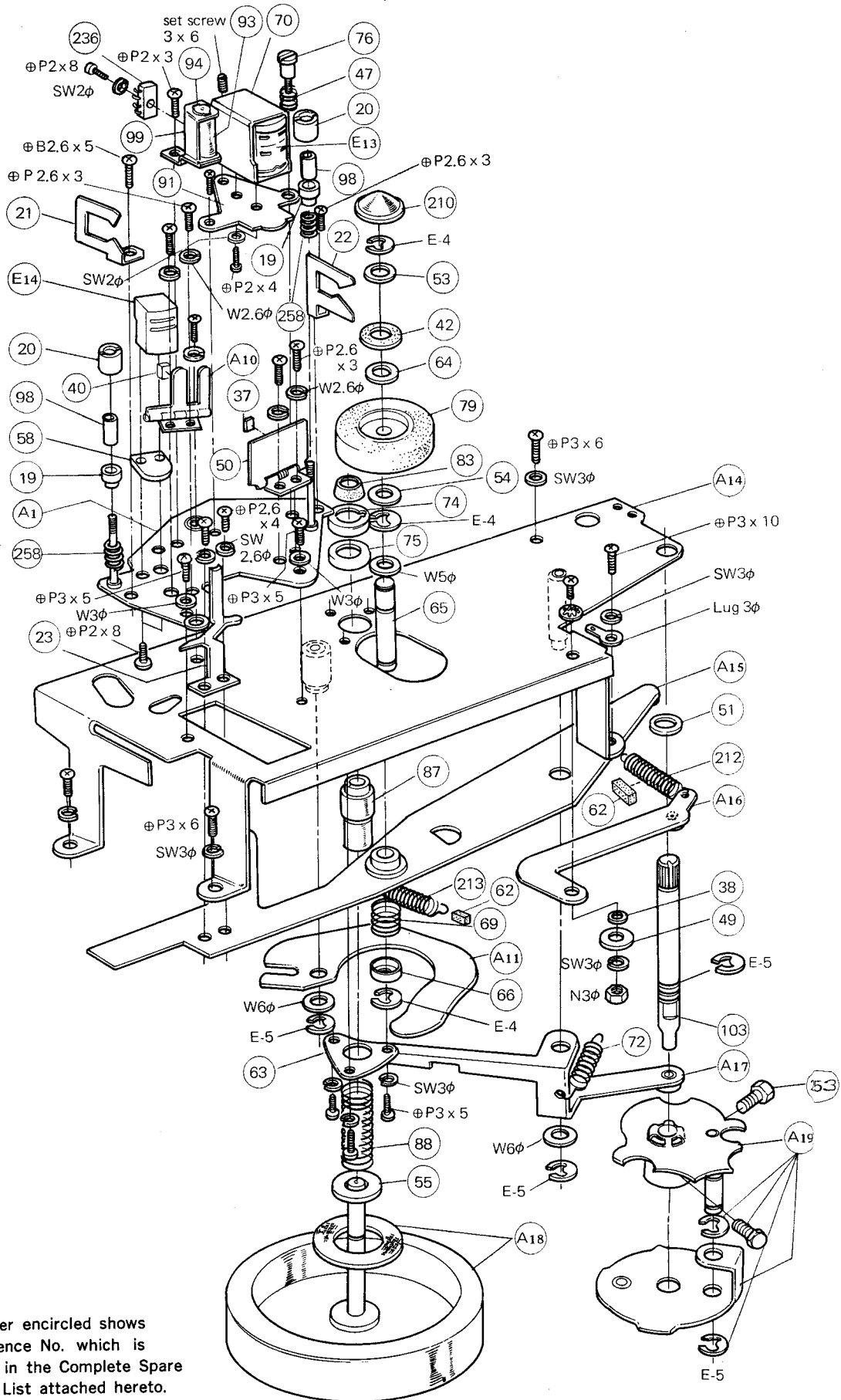

■ Number encircled shows Reference No. which is listed in the Complete Spare Parts List attached hereto.

Control chassis
 — Top view —

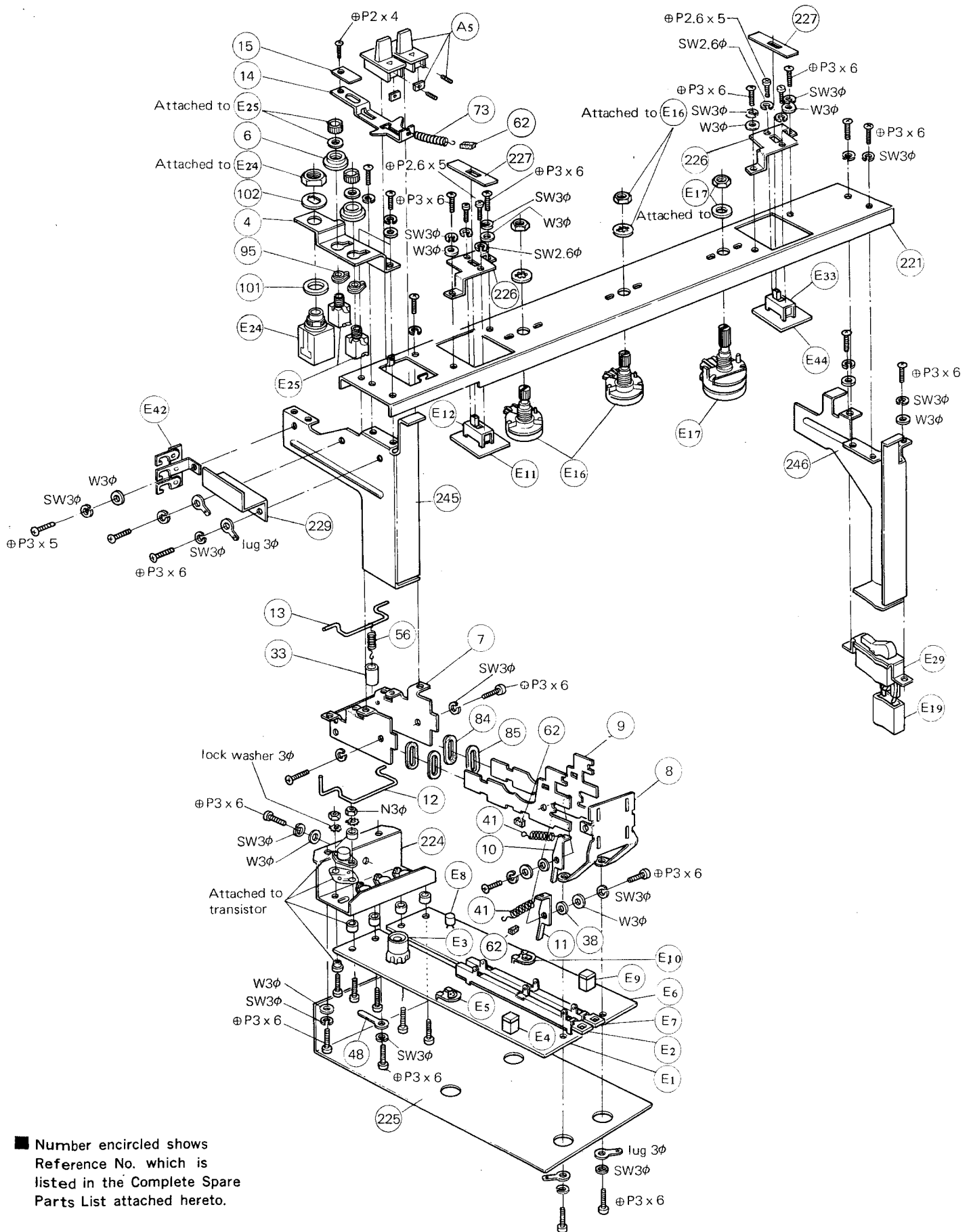

■ Number encircled shows Reference No. which is listed in the Complete Spare Parts List attached hereto.

**Chassis
- Top view -**

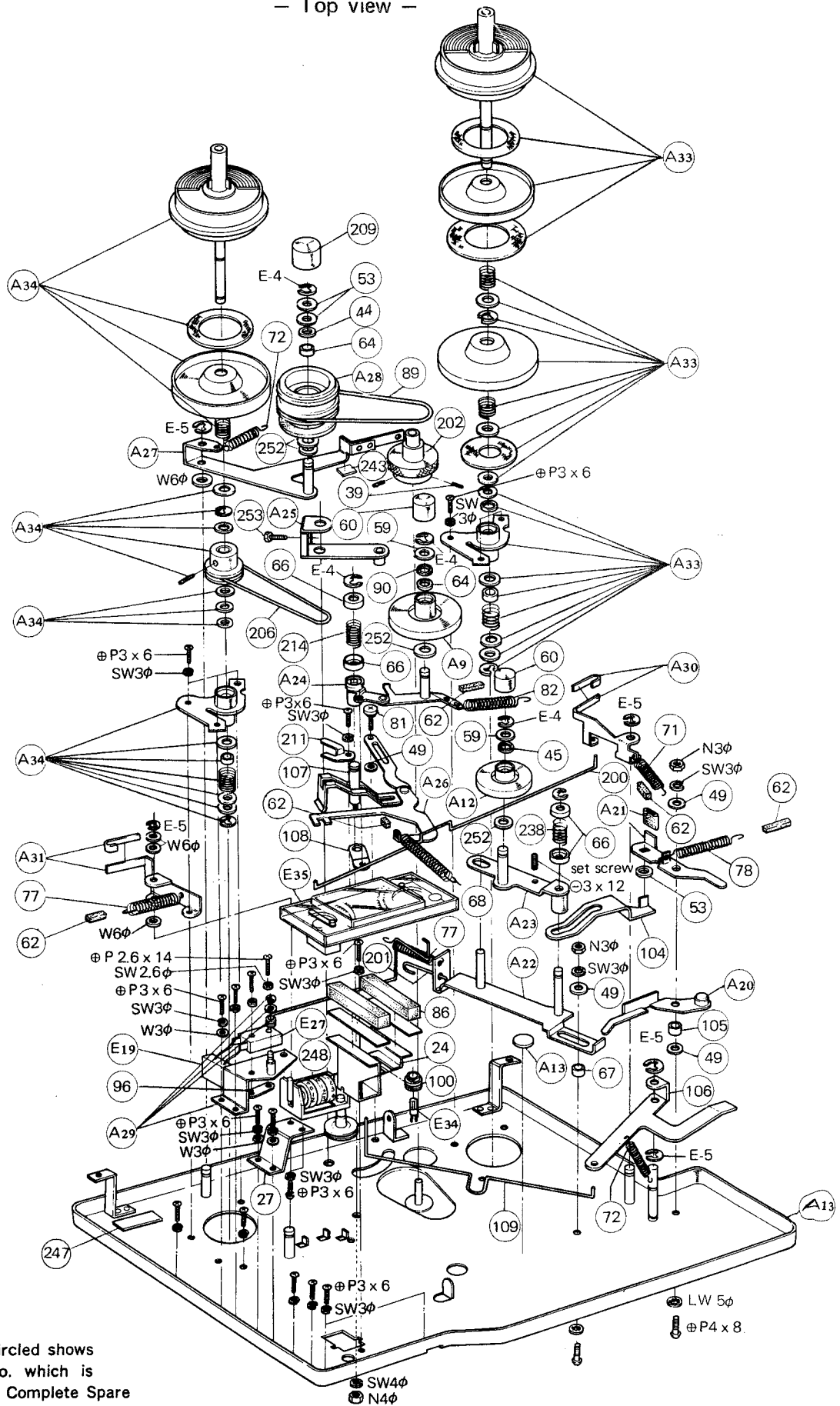

■ Number encircled shows Reference No. which is listed in the Complete Spare Parts List attached hereto.

Chassis — Bottom view —

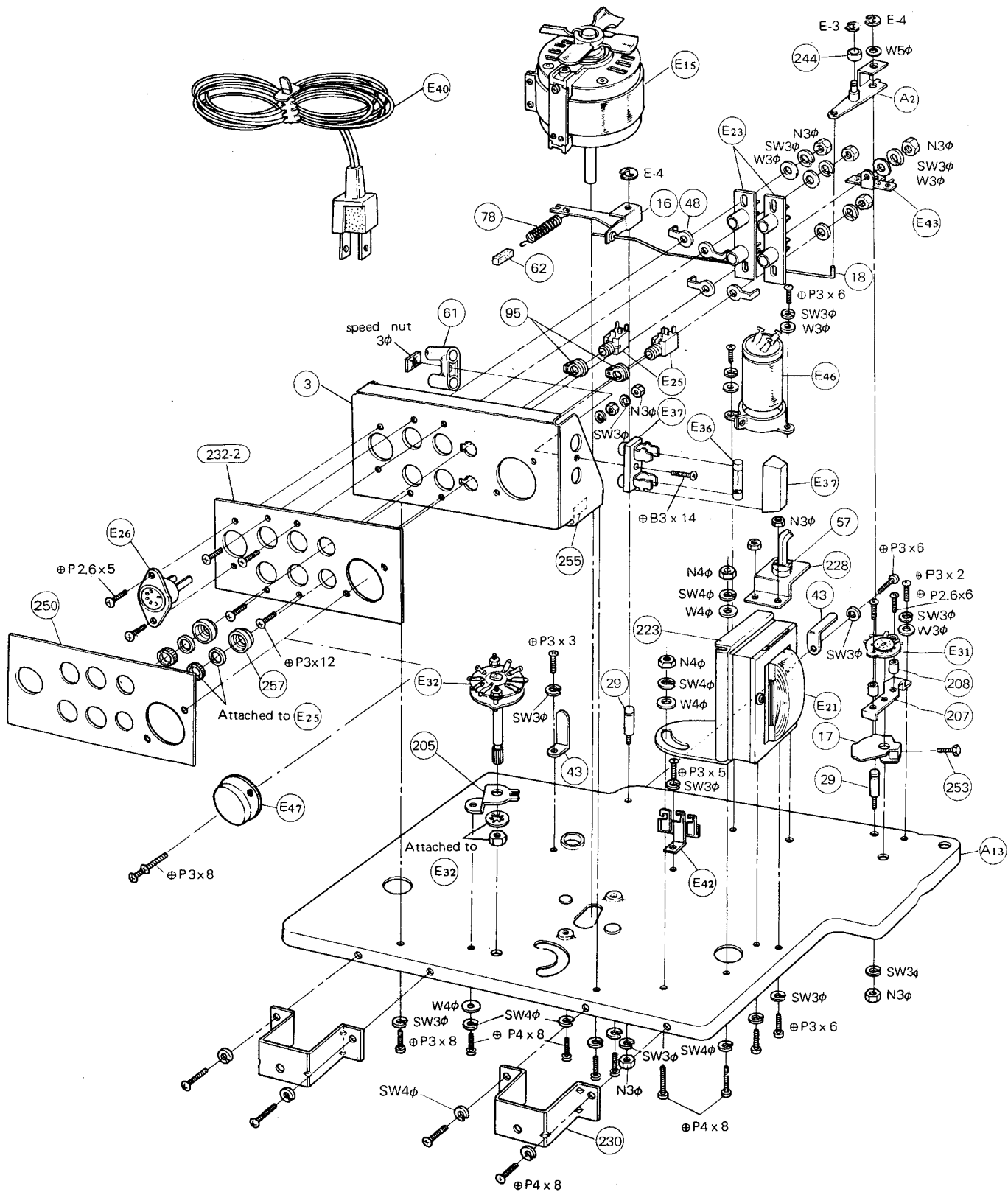

When ordering replacement parts you should use PART NUMBER listed on the Complete Spare Parts List attached hereto.
The reference number or symbol number should not be used for ordering purposes.

Number encircled shows Reference No. which is listed in the Complete Spare Parts List attached hereto.