

TC-350



Specifications

Power requirements :	50W, AC100V, 110V, 117V, 125V, 220V or 240V, 50/60 c/s (Only AC 117V 60 c/s for U. S. A.)
Reel :	7" or less
Tape speed :	7-1/2 and 3-3/4 ips. (19 and 9.5 cm/s)
Recording system :	4-track stereophonic or monophonic
Frequency response :	30~20,000 c/s at 7-1/2 ips. ± 3 db 50~15,000 c/s at 7-1/2 ips. 30~14,000 c/s at 3-3/4 ips.
Signal-to-noise ratio :	Better than 50 db
Flutter and wow :	Less than 0.17% RMS at 7-1/2 ips. Less than 0.25% RMS at 3-3/4 ips.
Harmonic distortion :	Less than 3% at 0 db (0.775V) line output
Level indication :	Two VU meters
	record : NAB standard
	playback : calibrated to 0 db (0.775V) line output
Fast forward and rewind time :	Within 4 min. (1,200' tape)
Input :	Microphone
	Sensitivity : -72 db (0.19 mV)
	Impedance : low (will accommodate any microphone with 250~1K Ω impedance)
	Auxiliary
	Sensitivity : -22 db (0.06 V)
	Impedance : approx. 100K Ω
	Integrated record/playback connector
	Sensitivity : -42 db (6.15 mV)
	Impedance : approx. 100 K Ω
Output :	Line
	Output level : 0 db (0.775 V)
	Impedance : optimum load impedance 100 K Ω
	Binaural monitor
	Output level : -1 db (0.692 V)
	Impedance : accommodates 10 K Ω headset
	Integrated record/playback connector
	Output level : 0 db (0.775 V)
	Impedance : optimum load impedance 500 K Ω
Transistor :	2SC402 \times 18, 2SB381 \times 2, 2SC291 \times 1
Diode :	1T22A \times 2, 5G-D \times 2
Dimensions :	15-3/4(W) \times 6-5/16(H) \times 13"(D) (400 \times 160 \times 320 mm)
Weight :	Approx. 17 lbs. 3 ozs. (7.8 kgs.)

SONY[®]
SERVICING GUIDE

Block Diagram

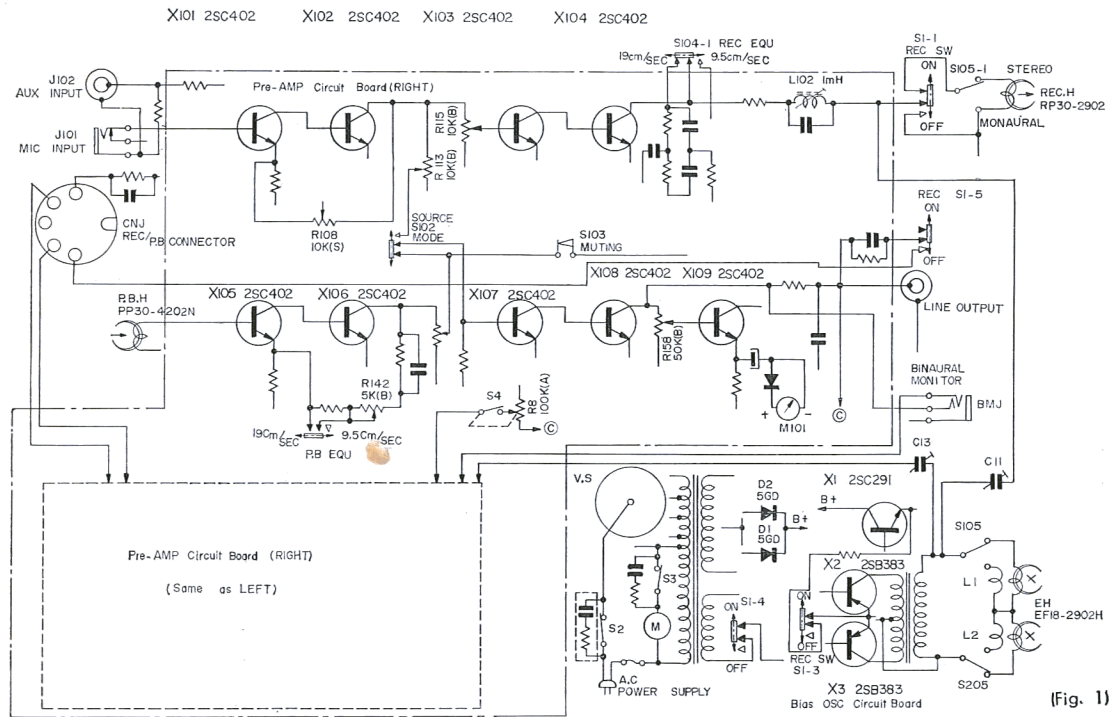

[Fig. 1]

Cabinet Top View

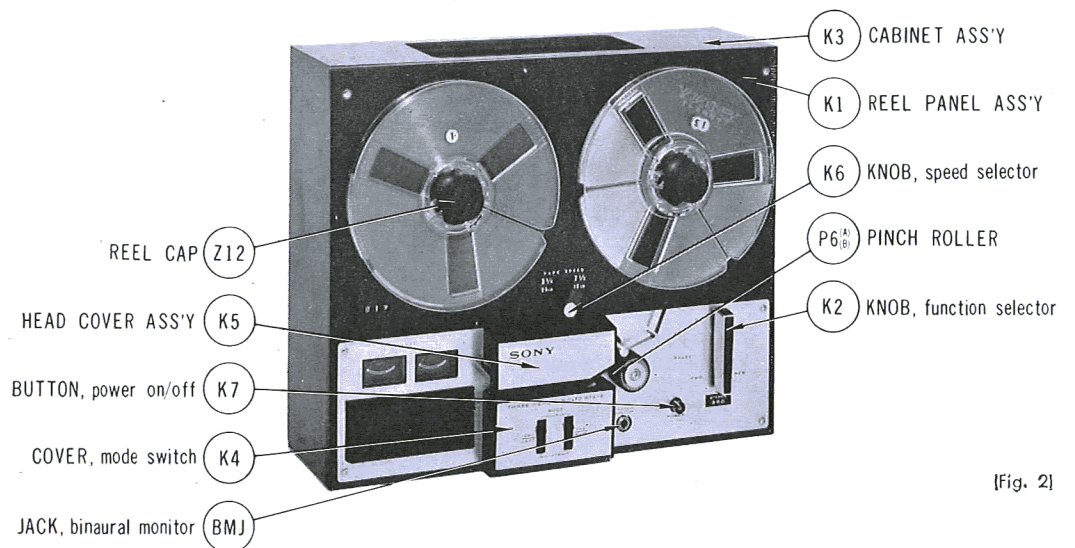

[Fig. 2]

Chassis Top View

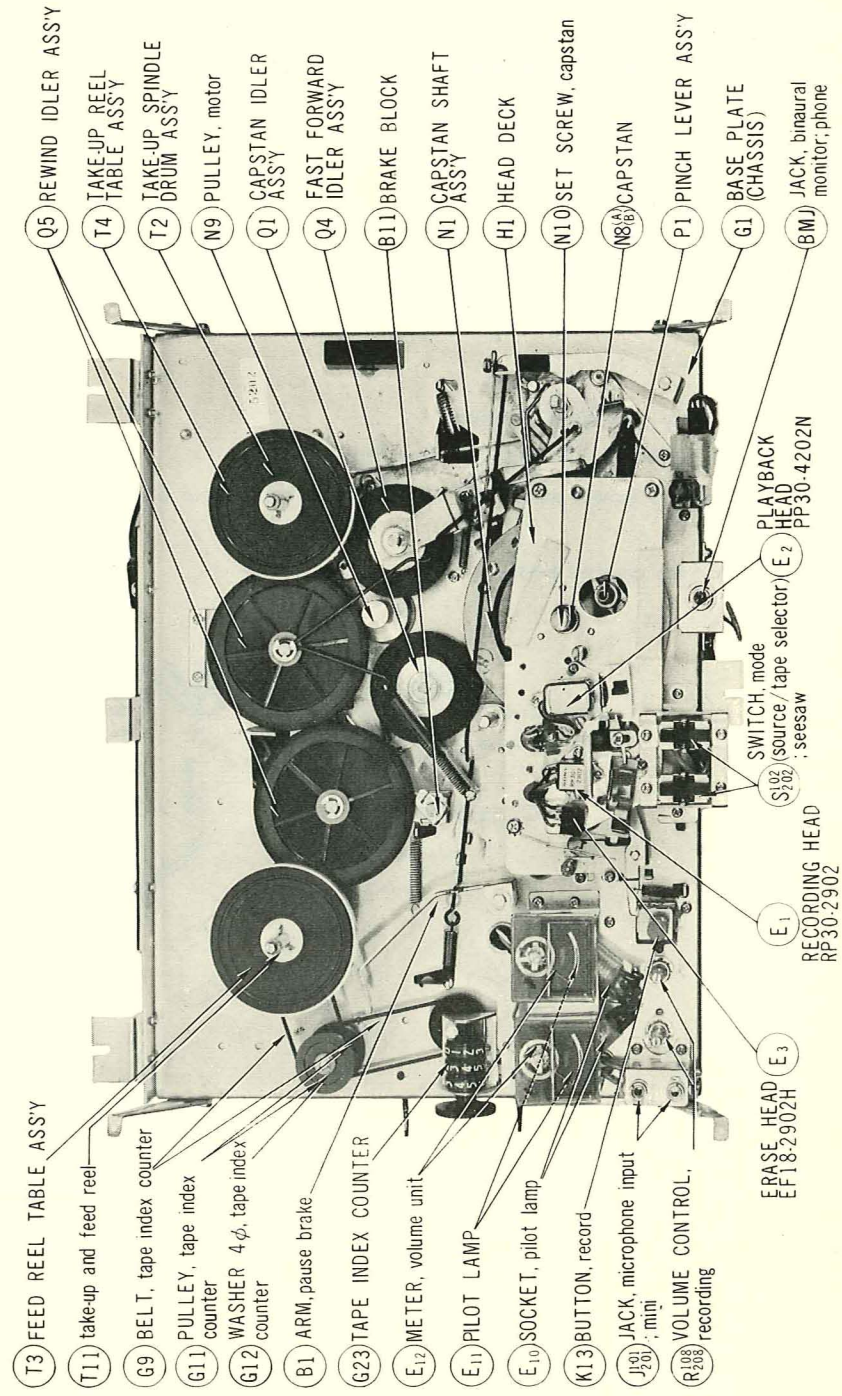

(Fig. 3)

Chassis Bottom View

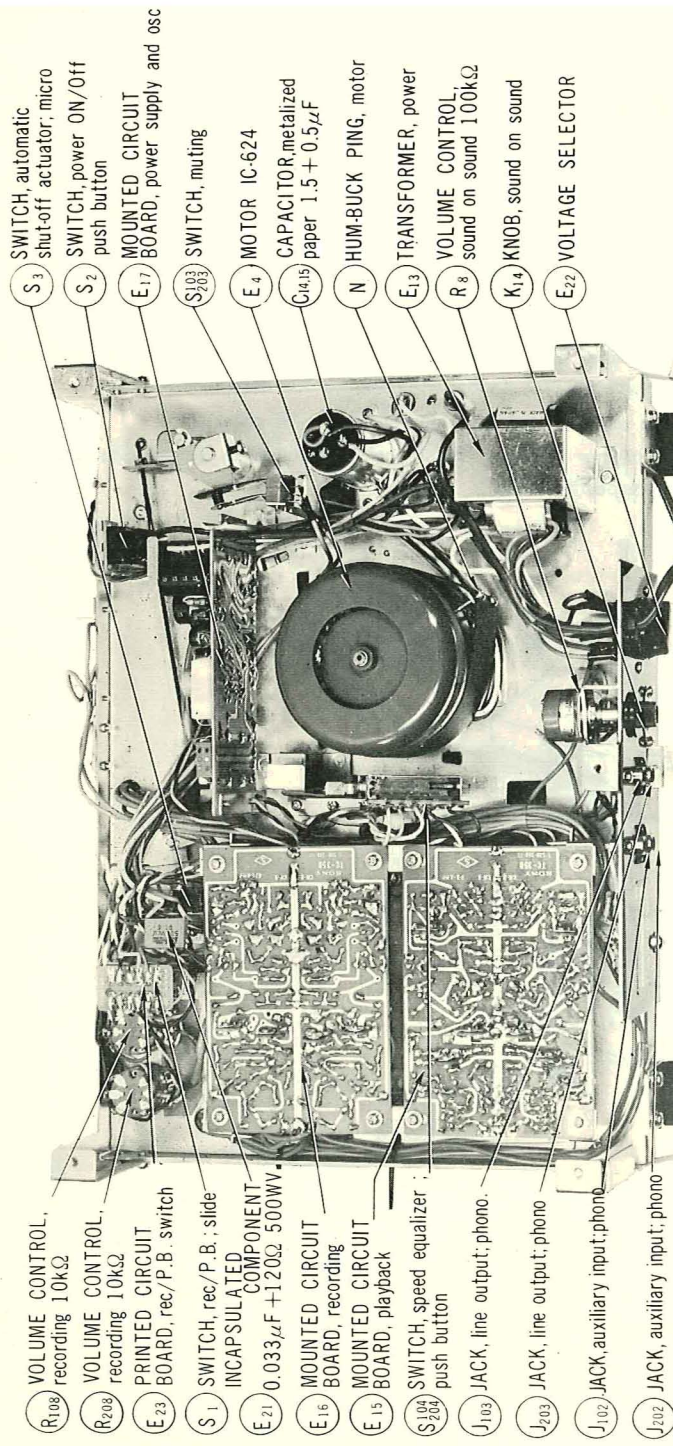

(Fig. 4)

Removal of Cabinet

1. Turn up-side down the recorder on a soft pad.
2. Remove four Screws (\oplus RF 4×20 marked with ▲ in Fig. 5), four Rubber Feet, one Screw (\oplus RF 4×10 marked with △ in Fig. 5), one Cabinet Spacer and Tone sound on Sound Control Knob as shown in Fig. 5.
3. Lift up the Cabinet gently.

Removal of Reel Panel

1. Remove Mode Switch Cover and Head Cover. (Fig. 1)
2. Remove Function Selector Knob, Speed Selector Knob and Pinch Roller by loosening the respective Set Screws. (Fig. 2)
3. Remove four Screws (\oplus B 3×6 marked with ▽ in Fig. 6.), four 3φ Washers, one Screw (\oplus RF 3×5 marked with ▼ in Fig. 6.) and one 3φ Washer as shown in Fig. 6.
4. Open the Cover for Recording Box and pull out two Record Volume Control Knobs.

Note: If the Record Volume Control Knobs are too tight to remove, try to lift Reel Panel up slightly and the Record Volume Control Knobs will come up for easy removal.

5. Now Reel Panel can be removed and main mechanism can be checked.

Note: When re-assembling the Reel Panel, the Record Volume Control Shafts must be located just at the center of the respective holes.

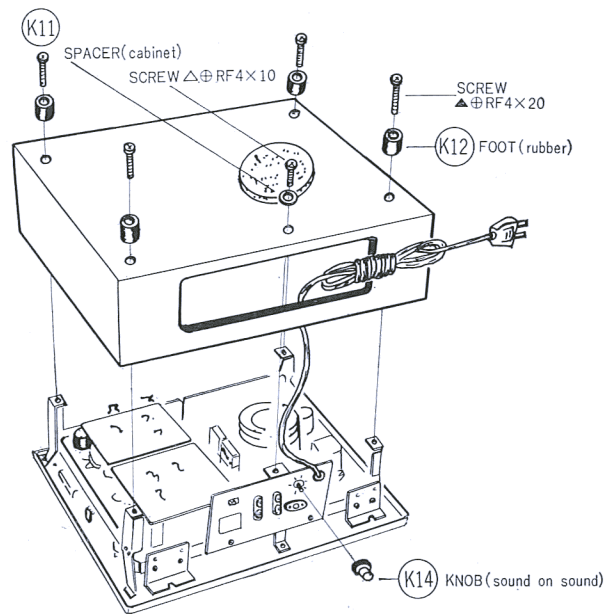

(Fig. 5)

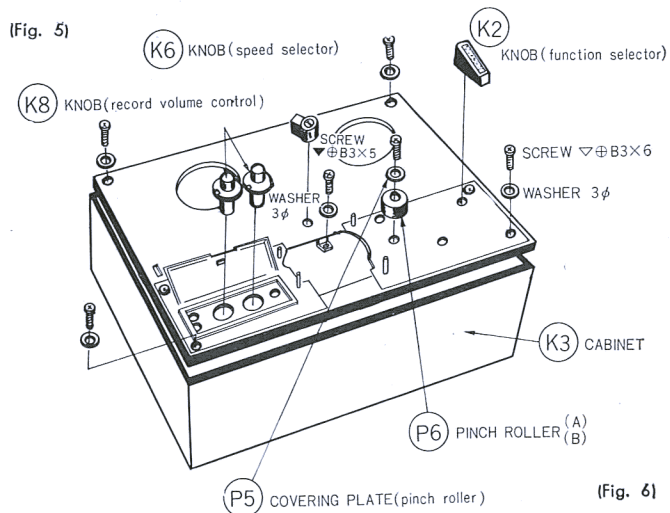

Removal of Printed Circuit Boards

Printed Circuit Boards can be checked without disassembled. When it is necessary to remove the Circuit Boards, proceed as follows :

Circuit Board for Playback Amplifier

1. Take out two Holding Screws (\oplus RF 3×6 marked with ○ in Fig. 7), two 3φ SPRING WASHERS and two 3φ WASHERS as shown in Fig. 7.
2. Slide the PRINTED CIRCUIT BOARD (playback amplifier) rightwards and remove it from the left Bracket as shown in Fig. 7.

Circuit Board for Recording Amplifier

1. Take out two Holding Screws (\oplus RF 3×6 marked with ◎ in Fig. 7), two 3φ SPRING WASHERS and two 3φ WASHERS as shown in Fig. 7.
2. Slide the PRINTED CIRCUIT BOARD (recording amplifier) leftwards and remove it from the left Bracket as shown in Fig. 7.

Circuit Board for Power Supply and OSC Section

1. Take out two Holding Screws (\oplus RF 3×6) marked with ☆ in Fig. 8.
2. Slide the PRINTED CIRCUIT BOARD (power supply and osc.) rightwards and remove it from the left Bracket as shown in Fig. 8.

Note: Take care not to cut the attached leads.

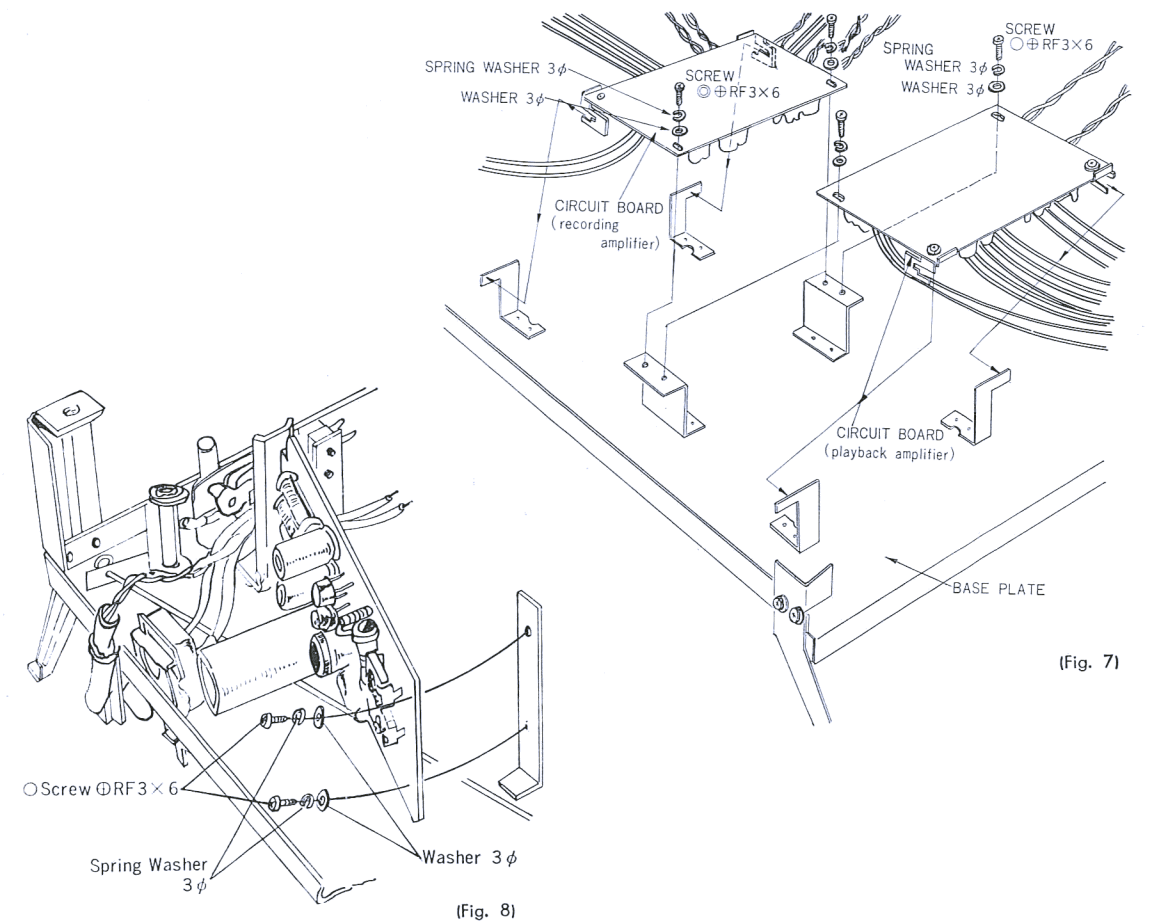

(Fig. 7)

(Fig. 8)

Lead Indication and Color Code of Silicon Transistor 2SC40 (A)-(B)

- The leads of the Transistor 2SC40(A)-(B) are attached in the order of Emitter, Collector and Base from the left with the marked side of the transistor faced up as shown in Fig. 9.
- Color Code 2SC40(A)-(B)
Color means the specified digit to be put in (A) and (B) as follows.

digit	1	2	3	4	5	6
Position of color mark						
A (left or upper side)	red	yellow	white			
B (right or lower side)	brown	red	orange	yellow	green	blue

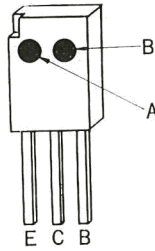

(A)

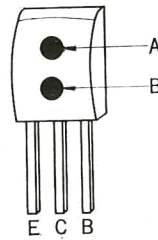

(B)

E...Emitter
C...Collector
B...Base

(Fig. 9)

To Install the Unit to other Equipment

When it is desired to install the Unit to other equipment, proceed as follows :

1. Remove the REEL PANEL referring to Fig. 6.
2. Remove the CABINET referring to Fig. 5.
3. Install the unit in opening ($15\text{-}1\frac{1}{8}'' \times 11\text{-}19\frac{3}{32}''$, $384 \times 294.4\text{ mm}$) on the Board with three WOOD SCREWS ($\oplus B 3 \times 6$) and Rack Mounting Bracket as shown in Fig. 10.

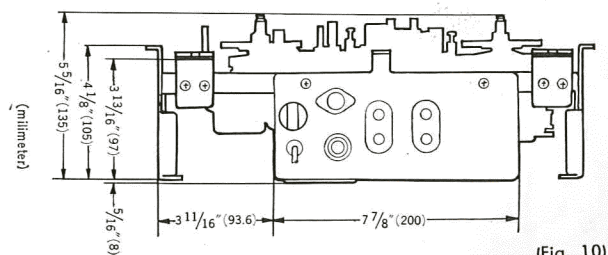
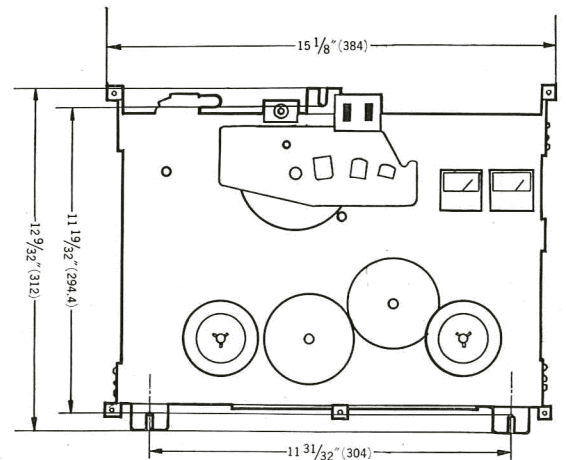
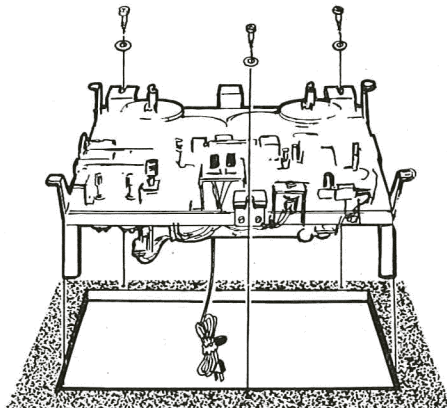

(Fig. 10)

Lead Connection for Voltage Selector Socket

When Voltage Selector Socket is replaced, wire the lead as shown Fig. 11.

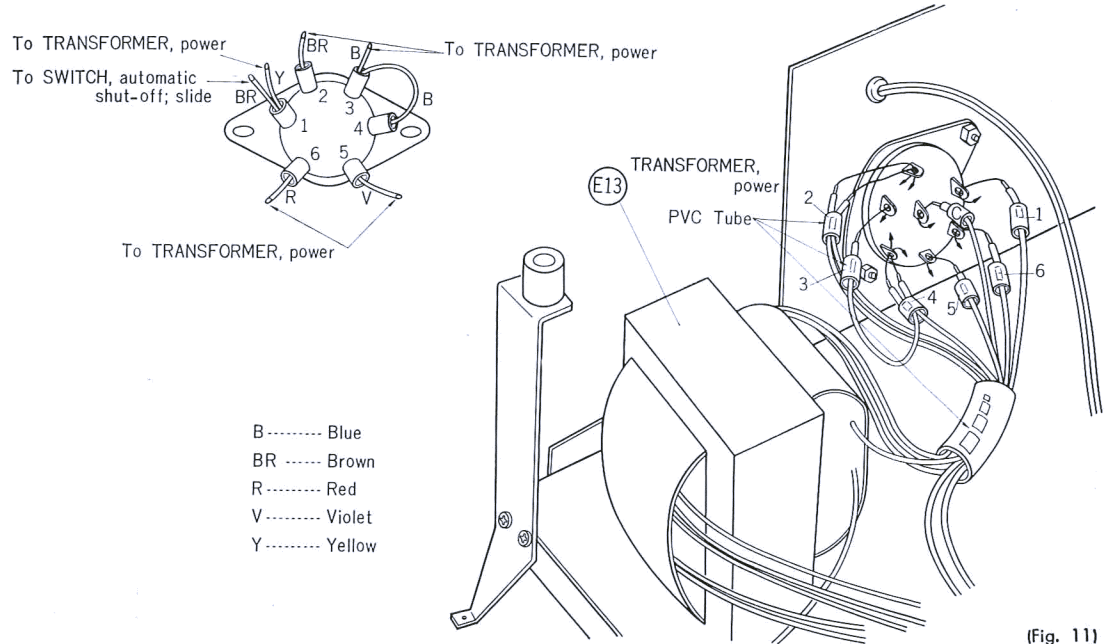

(Fig. 11)

Lead Connection for Volume Control (record) and Switch (rec/P.B.)

When Record Volume Control and Rec/P.B Switch is replaced, wire the lead as shown in Fig. 12.

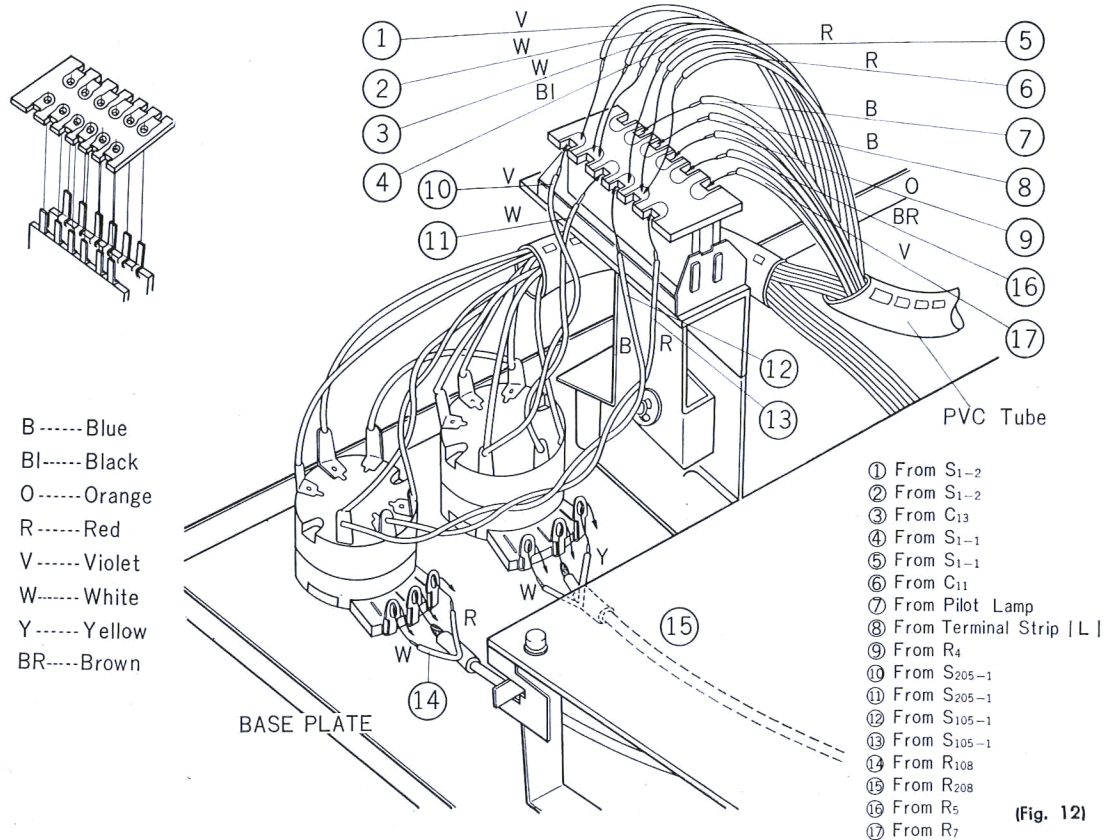

(Fig. 12)

Alignment Procedure

The alignment is to be performed at a tape speed of 7-1/2 ips unless otherwise specified.

Use the SONY Alignment Tape "N-19-F₂"

Connect two VTVMs to the Line Out Jacks (J₁₀₃ & J₂₀₃).

Playback Azimuth Alignment

1. Thread an alignment tape (N-19-F₂).
2. During playback of the 10 Kc/s of -22 dBs (59mV) tone recorded on the first section of the tape, adjust the azimuth alignment screw for maximum indication on the VTVM.

Note: 1. The azimuth alignment screw is located on the right side of the playback head.

Note: 2. The Playback Head Mounting Plate must always be kept 1.6 mm high from the HEAD DECK as shown in Fig. 14 which is set in the factory. As the correct positioning is very difficult without jig take care not to turn the adjustment screws, marked with ▲ shown in Fig. 14 even in replacing the Playback Head.

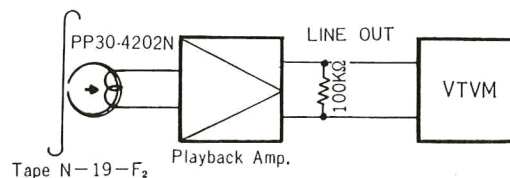

(Fig. 13)

Elevation Alignment

The exact vertical positionings of Head are adjusted at the factory and should never need readjustment.

However, when replacing Head or Tape Guide, height of the replaced part in relation to the tape should be checked as follows ;

1. Thread a tape.
2. Align the upper edges of the Head Cores and upper edge of the tape by turning the Tape Guide located on the left side of the Erase Head.
3. Turn the Tape Guide clockwise by approximately 20° from the position obtained in the preceding process, so that the upper edge of the tape is approximately 0.025 mm lower than that of the Erase Head Core.

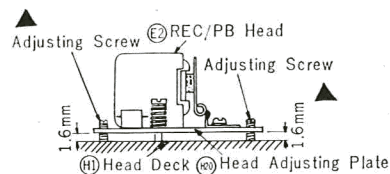

(Fig. 14)

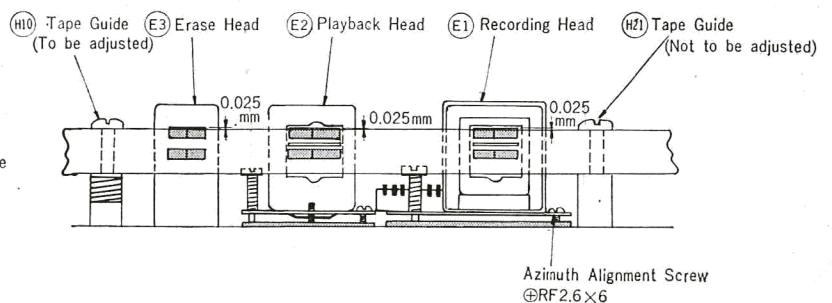

(Fig. 15)

Record Azimuth Alignment

1. Switch the monitor to the tape position.
2. Feed a 10 Kc signal of -80 dBs ($77.5 \mu V$) on both channels through the Mic. Jacks (J_{101} & J_{201}).
3. Adjust the azimuth alignment screw of the Record Head for maximum output reading on the VTVM.

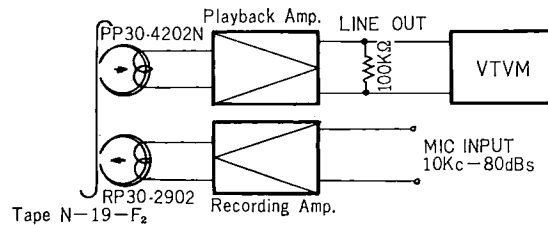

Recording Bias Alignment

1. Set the machine in record mode.
2. Thread a blank tape on the machine.
3. Set the Monitor Switches, S_{102} and S_{202} to the tape position.
4. Feed a 1 Kc signal of -60 dBs ($0.775 mV$) into the Mic Jack.
5. Turn the Trimmer Capacitor clockwise slowly. The VTVM reading will go up, reaching a maximum and then falling again. Continue to turn the Trimmer Capacitor until the VTVM reads 0.5 dB below the maximum value.

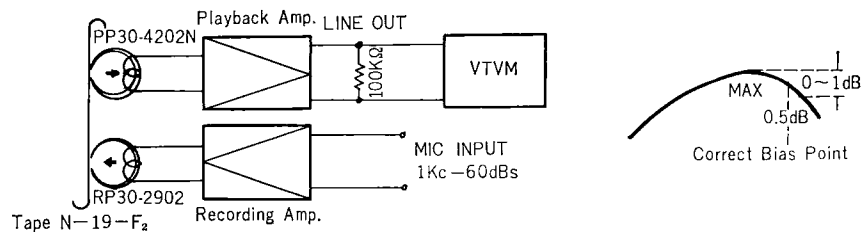

Source Monitor Level Alignment

1. Feed a 1 Kc signal of -75 dBs ($0.135 mV$) to the Mic. Input Jack (J_{101} & J_{201}).
2. Turn the Volume Controls, R_{108} and R_{208} , counter-clockwise to the full.
3. Set the Monitor Switch (S_{102} and S_{202}) to the source position.
4. Set the Adjustable Resistors, R_{113} and R_{213} , to get line output of 0 dBs. ($0.775 V$)

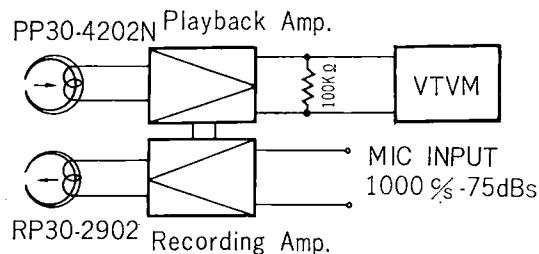

Recording Level Alignment

1. Set the Monitor Switch (S_{102} and S_{202}) to the source position.
2. Feed a 1Kc signal of -60 dBs (0.775 mV) into the Mic Input Jack. (J_{101} and J_{201})
3. Turn the Volume Controls R_{108} and R_{208} clockwise to the full so that line output level is 0 dBs. (0.775 V)
4. Set the Monitor Switch (S_{102} and S_{202}) to the tape position.
5. Record a 1Kc signal of -60 dBs. (0.775 mV)
6. Playback a signal recorded in the step 5 and set the Adjustable Resistors, R_{115} and R_{215} , so that line output level is 0 dBs. (0.775 V)

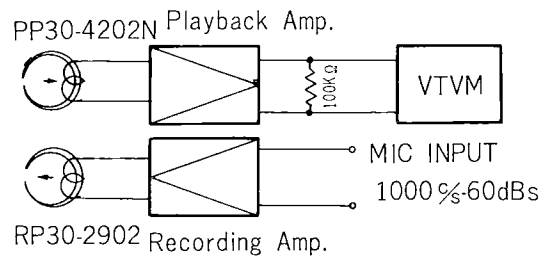

Playback Output Level Adjustment

1. Playback the 700 c/s of -12 dBs (190 mV) tone recorded on the second section of the alignment tape (N-19-F₂).
2. Adjust R_{147} and R_{247} so that line output level is 0 dBs (0.775 V). Standard: 0 dBs ± 1.0 dB.

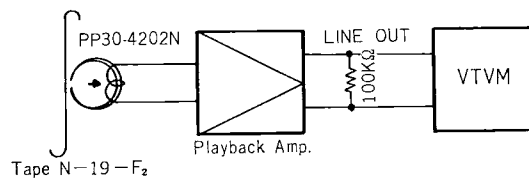

Bias Trap Adjustment

1. Set the machine in record mode without threading a tape.
2. Connect a VTVM to Line Output Jack (J_{103} & J_{203}) and place Trimmer Capacitors (C_{11} & C_{13} in Fig. 16) to maximum.
3. Adjust the Trap Coil (L_{102} & L_{202}) for minimum indication on the VTVM.

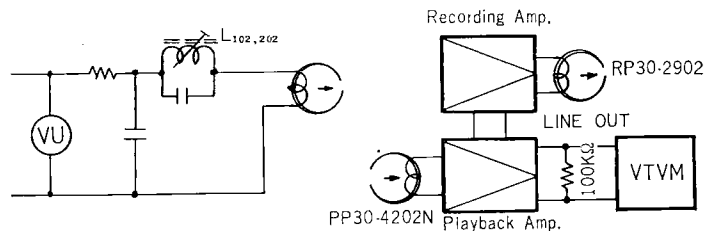

Playback Level Adjustment

1. Playback the 700 c/s of -12 dbS tone recorded on the second section of the alignment tape (N-19-F₂)
2. Adjust the Potentiometers, R₁₅₈ and R₂₅₈, so that the pointer of the Level Meter is just at the boundary between the Red portion and the White portion while keeping line output at 0 dbS (0.775V).

Note: Tolerance should be ± 3 mm from the center of the boundary.

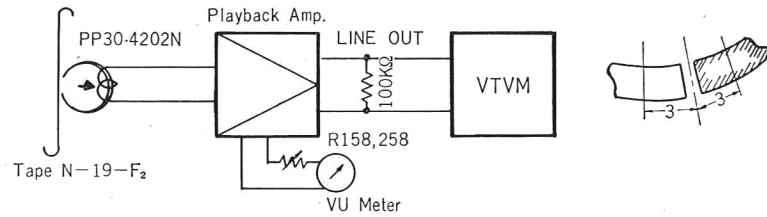

Modification to different power line frequency

	For 50 c/s	For 60 c/s
1. Connection between terminals of the Metalized Paper Capacitor (MP.)	Connected (2 μ F)	Disconnected (1.5 μ F)
2. Pinch Roller	0-027-476-01 (Red)	0-027-477-01 (White)
3. Capstan	0-027-483-05 (Red)	0-027-483-06 (White)

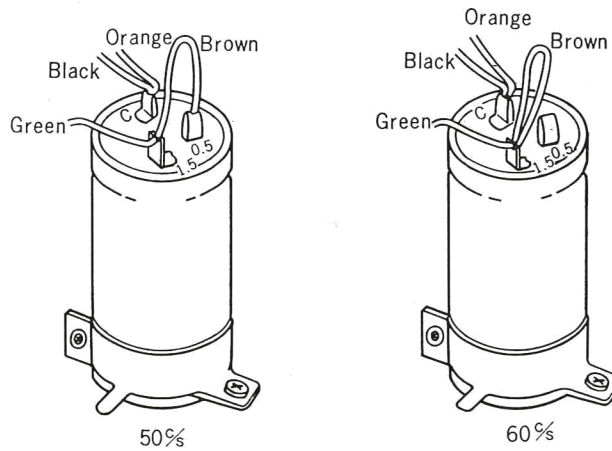

Mounting Diagram
Playback Amplifier Section

— Printed Side —

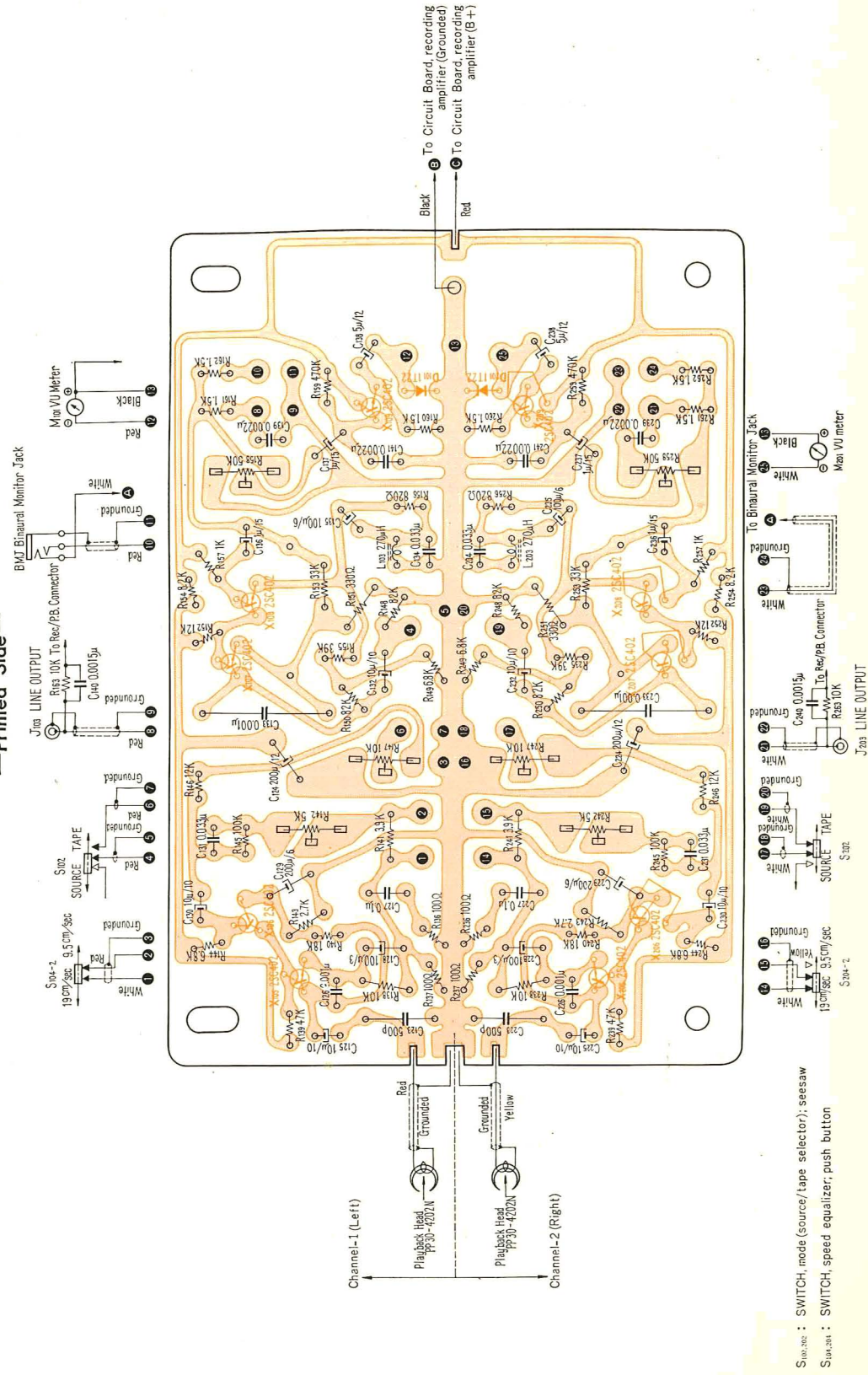

Mounting Diagram
Playback Amplifier Section

— Parts Side —

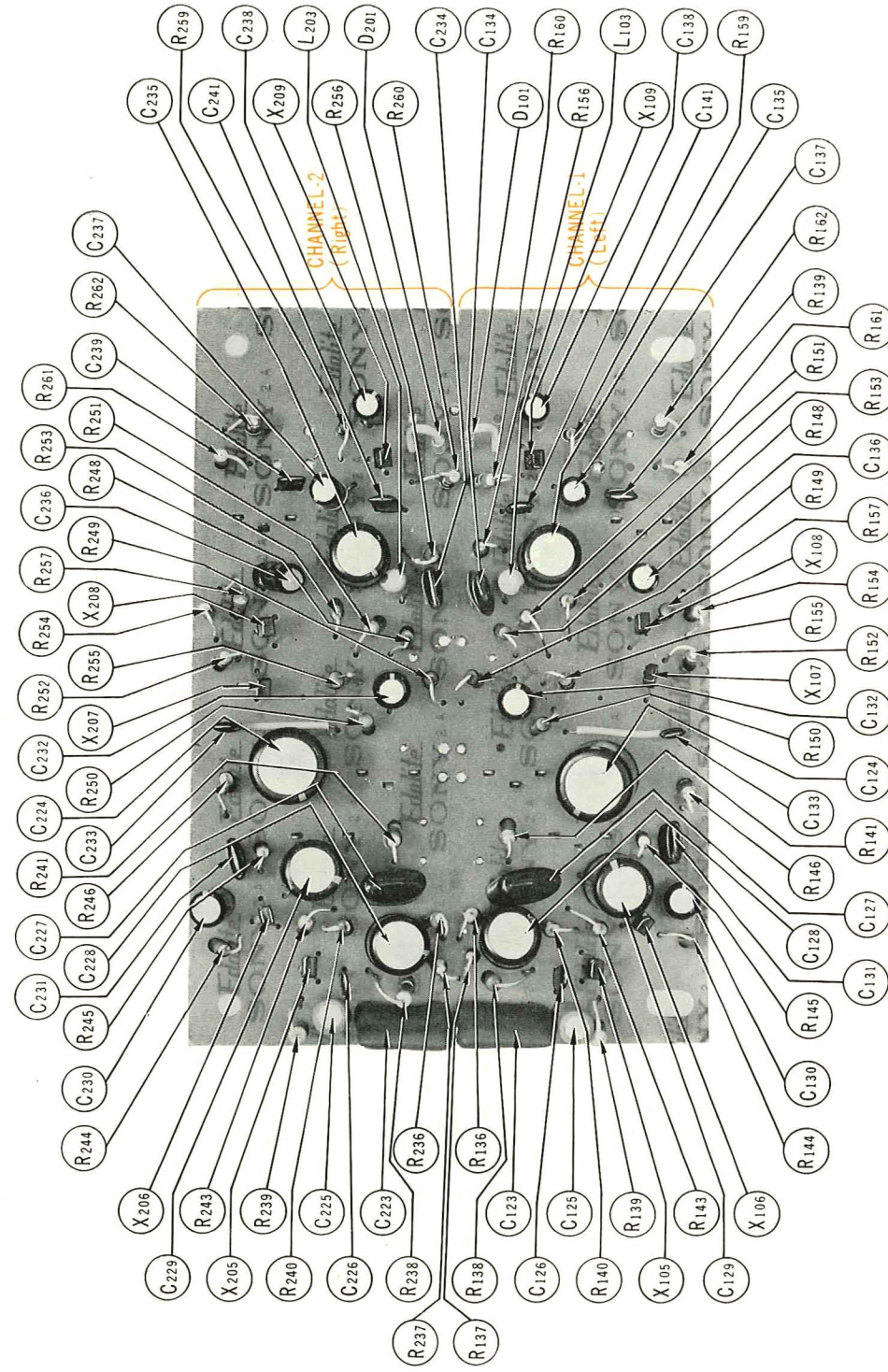

Mounting Diagram
Recording Amplifier Section

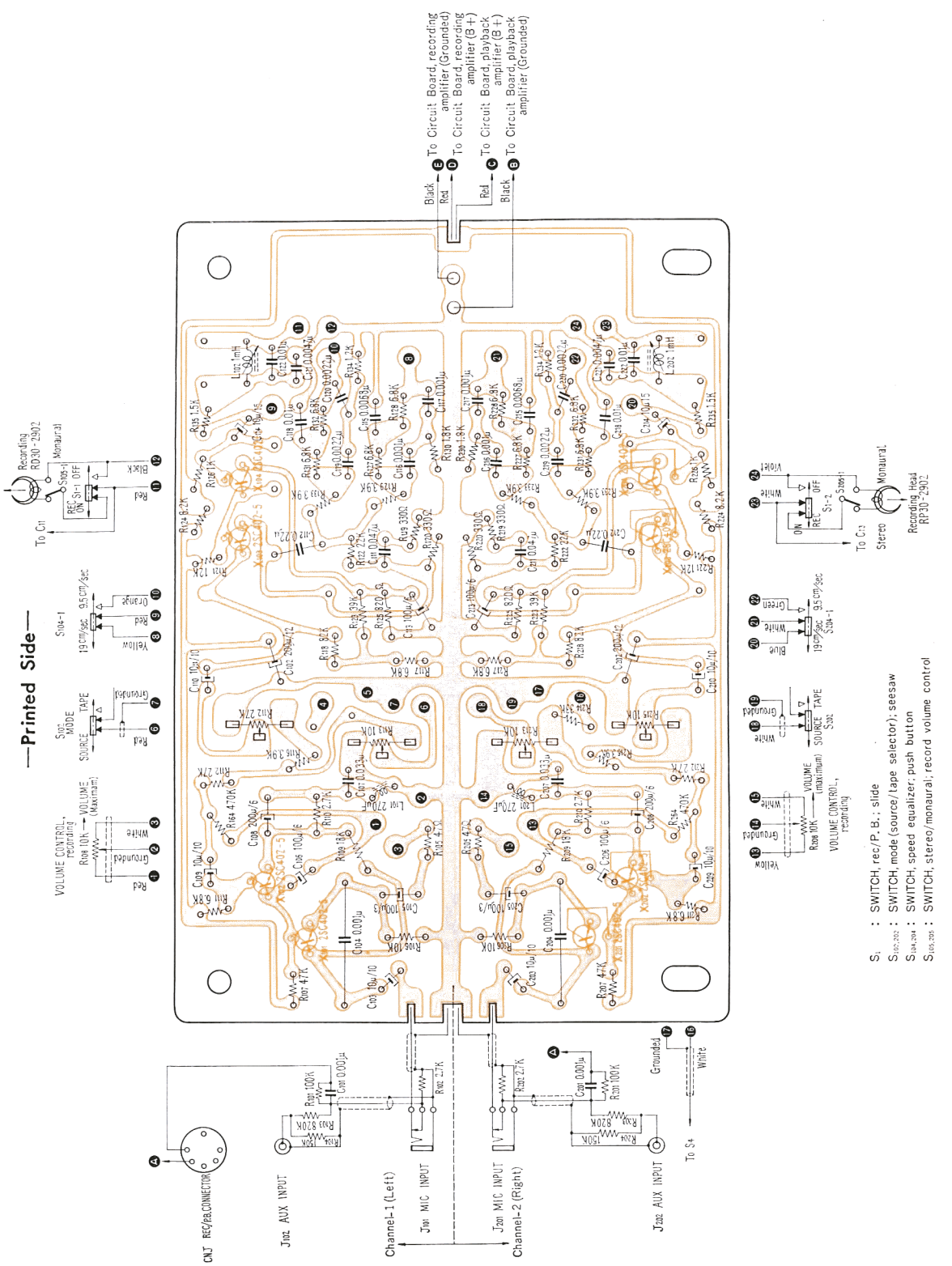

Mounting Diagram
Recording Amplifier Section

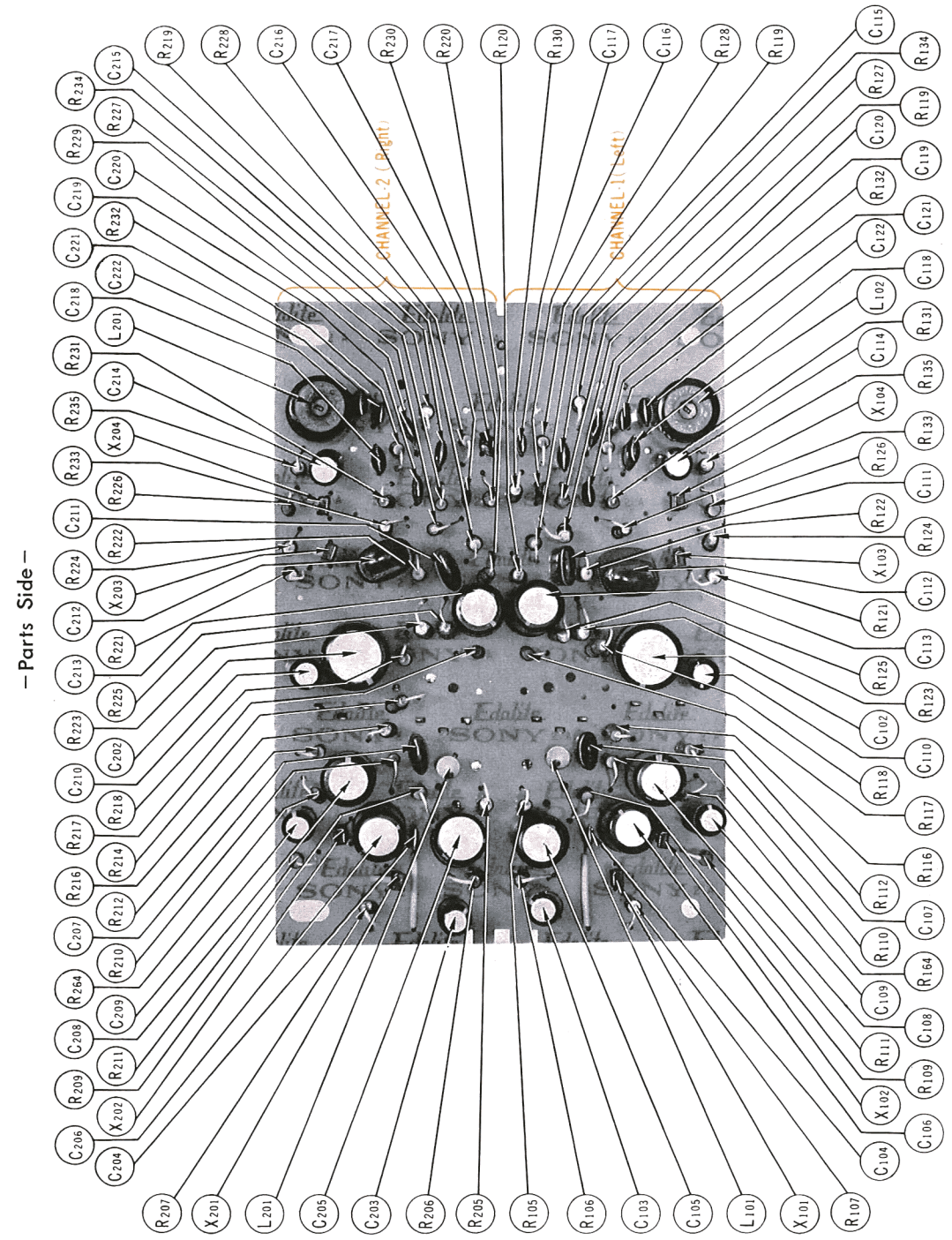

Mounting Diagram
Power Supply and OSC Section

-- Printed Side --

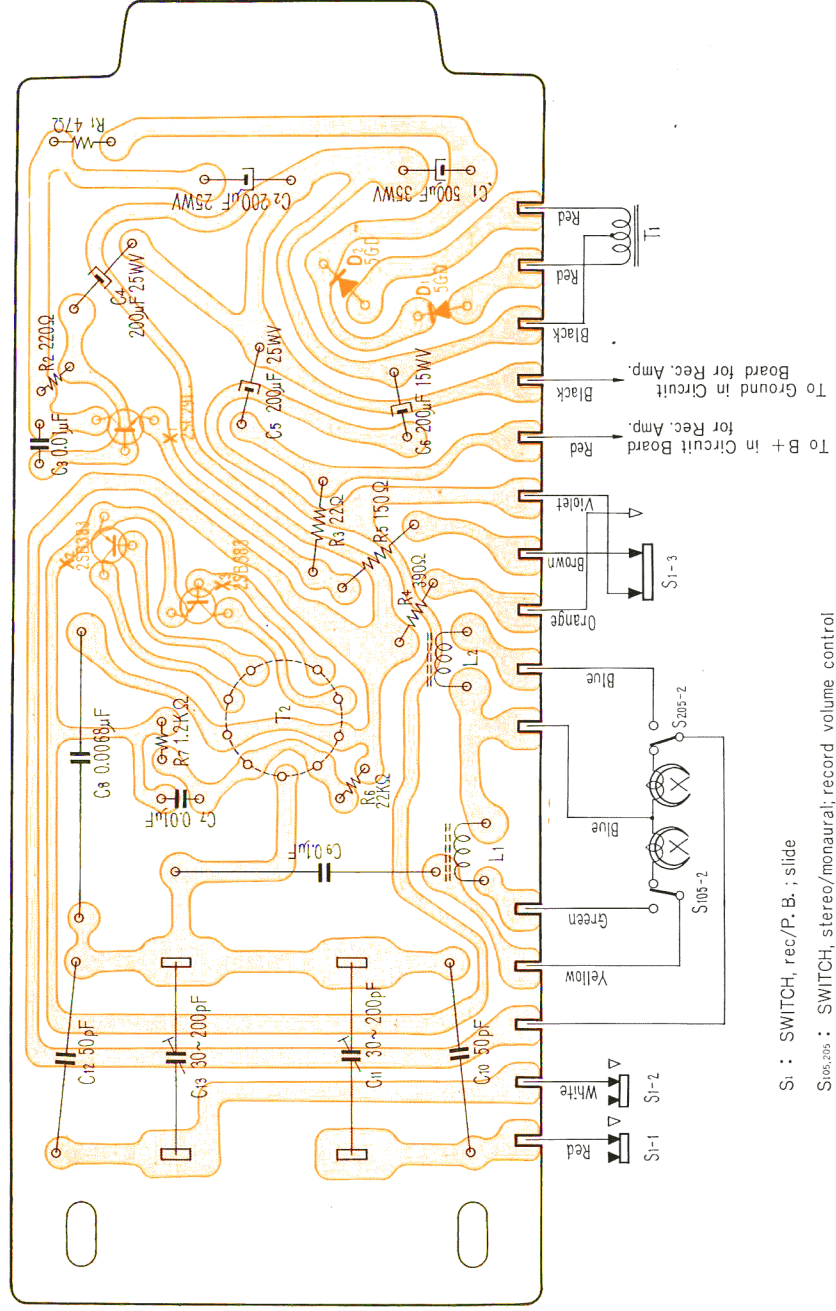

S₁ : SWITCH, rec/P. B. ; slide

S_{205.205} : SWITCH, stereo/monaural, record volume control

Mounting Diagram
Power Supply and OSC Section

-- Parts Side --

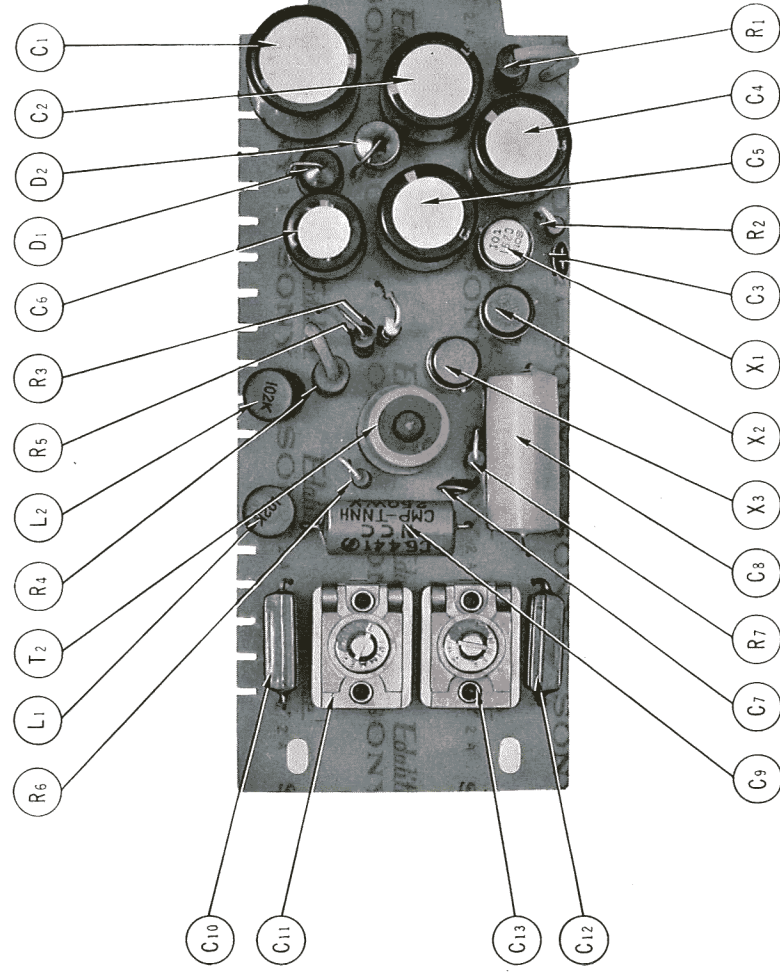

Circuit Schematic

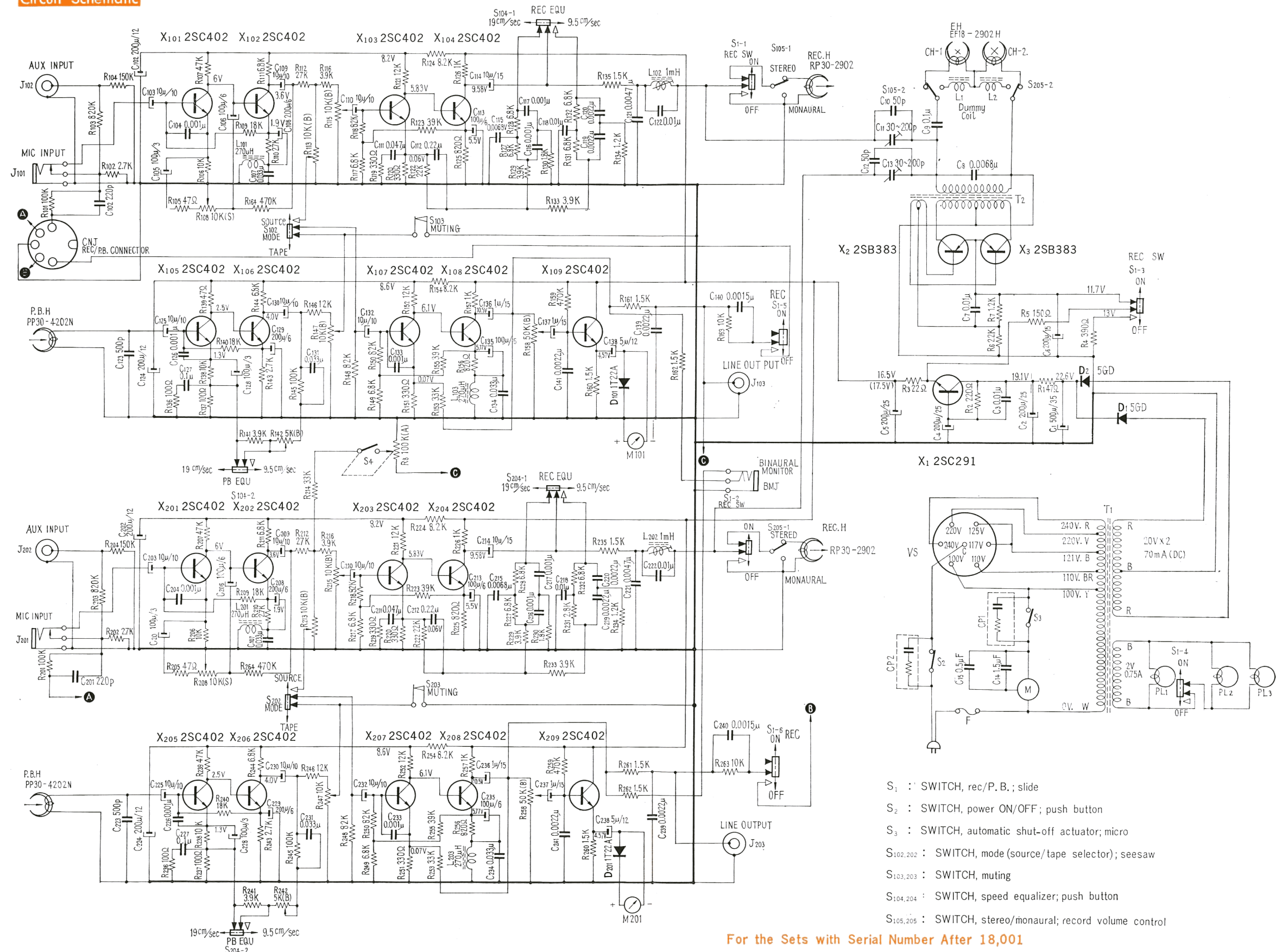

- S₁ : SWITCH, rec/P. B.; slide
- S₂ : SWITCH, power ON/OFF; push button
- S₃ : SWITCH, automatic shut-off actuator; micro
- S_{102,202} : SWITCH, mode (source/tape selector); seesaw
- S_{103,203} : SWITCH, muting
- S_{104,204} : SWITCH, speed equalizer; push button
- S_{105,205} : SWITCH, stereo/monaural; record volume control

For the Sets with Serial Number After 18,001

Recording Level Diagram

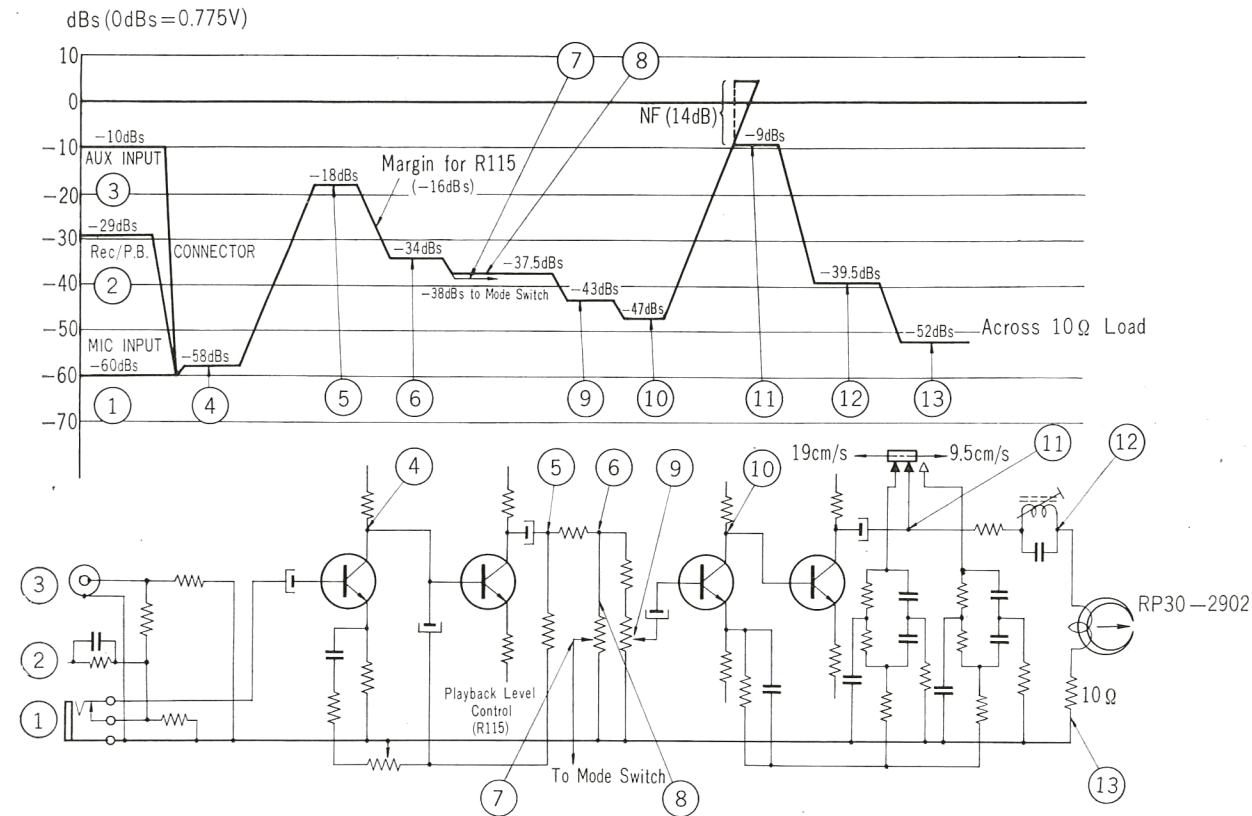

Playback Level Diagram

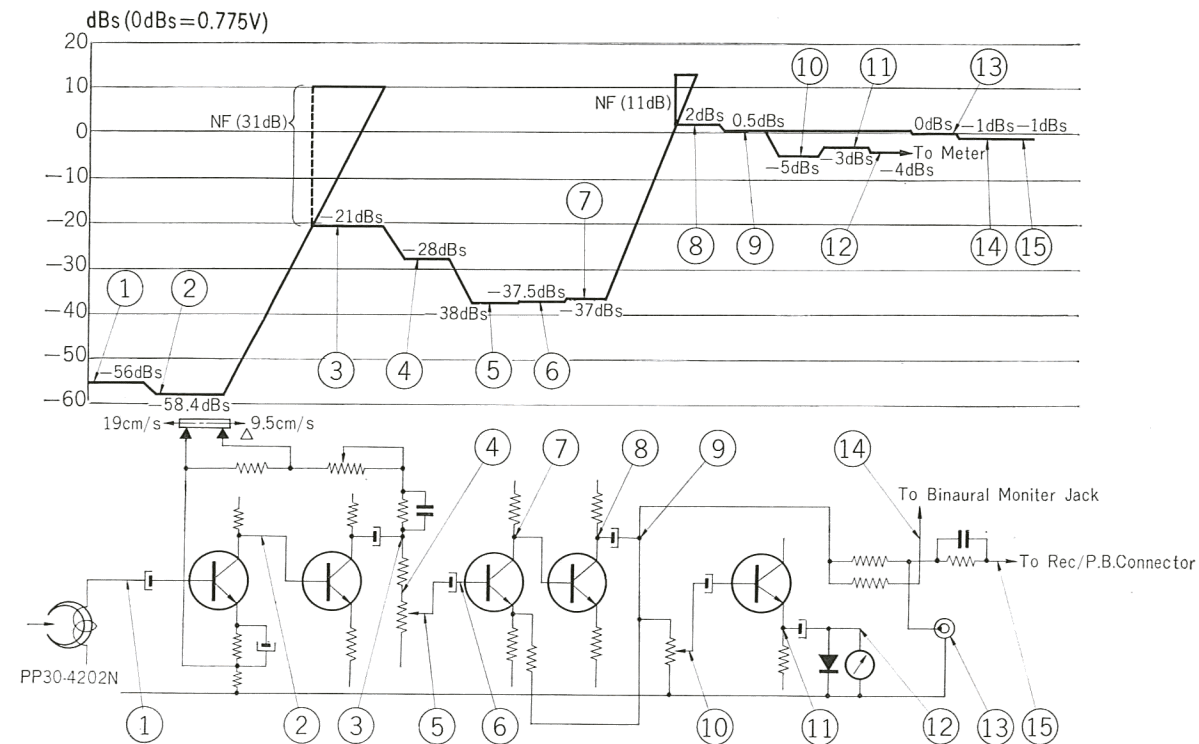

Parts List

Part No.	Symbol No.	Description	Part No.	Symbol No.	Description
		K. CABINET & APPEARANCE ITEMS	7-623-207-22	K1-14	WASHER, spring 2.6φ
			-208-22	K1-15	WASHER, spring 3φ
X-34280-06-3	K1	REEL PANEL ASS'Y	X-34280-08-	K2	KNOB, function selector
3-428-011-	K1-1	REEL PANEL	3-409-106-	K2-1	SET SCREW, function selector
-012-02	K1-2	DECORATION WASHER	X-34280-09-	K3	CABINET ASS'Y
0-027-179-	K1-3	STUD, head cover holding	3-402-777-	K3-1	VENTILATOR
3-409-108-	K1-4	NYLON WASHER, reel panel	X-34280-10-1	K4	COVER, mode switch
3-418-012-01	K1-5	TAPE GUIDE	3-428-023-01	K4-1	DECORATION PLATE, gold
3-419-091-	K1-6	FELT WASHER, black	X-34280-11-1	K5	HEAD COVER ASS'Y
-204-	K1-7	RECORDING BOX	3-428-025-02	K5-1	DECORATION PLATE, gold
-217-	K1-8	SPECIAL NUT (A)	X-34090-12-8	K6	KNOB, speed selector
-222-	K1-9	SPECIAL NUT (B)	3-403-454-	K6-1	SET SCREW, speed selector knob
7-621-255-56	K1-10	SCREW, MACHINE; pan head phill. 2x6	X-34190-06-	K7	BUTTON, power on/off
-770-52	K1-11	SCREW, MACHINE; binding head phill.	3-428-134-01	K8	KNOB, record volume control
7-622-207-02	K1-12	NUT, lock 2.6φ	0-051-221-	K9	SPACER, power on/off button
-208-02	K1-13	NUT, lock 3φ	3-409-108-	K10	WASHER, reel panel
			-191-	K11	SPACER, cabinet
			3-424-049-	K12	FOOT, rubber
			3-419-053-	K13	BUTTON, record
			-062-1 1/2	K14	KNOB, sound on sound

Part No.	Symbol No.	Description	Part No.	Symbol No.	Description
		A. AMPLIFIER BLOCK	3-428-101-	G4	BRACKET, mode selector switch
0-051-235-	A1	BRACKET, wire retainer	-102-	G5	BRACKET, binaural monitor jack
-428-	A2	WASHER, terminal strip insulating	-105-	G6	PLATE, pilot lamp holding
3-401-156-	A3	SPACER, mini jack	-113-	G7	BRACKET (B), printed circuit board
-179-	A4	WIRE RETAINER	-114-	G8	BRACKET (C), printed circuit board
		B. BRAKE BLOCK	0-037-205-	G9	BELT, tape index counter
3-428-103-	B1	ARM, pause brake	3-103-527-	G10	RUBBER STAPLE
-117-	B2	ARM, brake (take-up reel)	3-407-040-	G11	PULLEY, tape index counter
-124-	B3	ROD, pause brake control	-071-	G12	WASHER 4φ, tape index counter pulley
-133-	B4	SPRING, pause brake control rod	3-410-032-	G13	VINYL STAPLE, AC power cord
-135-	B5	BRAKE SHOE, pause brake arm	3-413-090-	G14	SHAFT, tape index counter pulley shaft
0-027-200-	B6	SPRING, brake block	3-419-003-	G15	METAL LEG (A), base plate
-249-	B7	BRAKE FELT, brake arm	-004-	G16	METAL LEG (B), base plate
0-037-240-	B8	SPRING, brake arm (take-up reel)	-010-	G17	BRACKET, volume unit meter
0-051-076-	B9	LEVER, pause brake selection control	-028-	G18	BRACKET, muting switch
3-402-706-	B10	SPRING, brake arm (feed reel)	-029-	G19	PLATE, pilot lamp
3-419-093-	B11	BRAKE BLOCK	-043-	G20	SPACER, tape index counter pulley
		F. FUNCTION SELECTOR MECHANISM	-057-	G21	CUSHION, volume unit meter
			-059-01	G22	BRACKET, microphone jack
			Y-20071-01-1	G23	TAPE INDEX COUNTER
		G. DECK BLOCK			H. HEAD DECK BLOCK
X-34280-03-	F1	CAM, function selector	X-34280-02-	H1	HEAD DECK
X-00270-12-	F2	ARM, stepper	X-34120-04-	H2	HEAD HINGE ASS'Y
0-027-134-	F3	SPACER, stepper arm	X-34120-15-	H3	PLATE, head shield
0-037-018-	F4	SPRING, stepper arm	3-428-106-	H4	SPACER, playback head
3-419-025-	F5	CAM, muting switch	-125-	H5	SPACER, head hinge
-040-	F6	SHAFT, function selector cam	-132-	H6	SPRING, playback head adjusting
-080-	F7	SET SCREW, function selector cam	0-027-473-	H7	TAPE PAD, playback & erase head
			0-051-363-	H8	TAPE PAD (LARGE), head shield plate
X-34280-01-	G1	BASE PLATE (CHASSIS)	0-056-312-	H9	TAPE PAD (SMALL), head shield plate
0-027-040-	G1-1	THRUST DISC. vulcanized fiber	3-103-201-	H10	TAPE GUIDE (LEFT)
X-34280-07-	G2	BRACKET, jack mounting	-203-	H11	SPRING, tape guide adjusting
X-34190-08-	G3	BRACKET, rack mounting			

Parts List

Part No.	Symbol No.	Description	Part No.	Symbol No.	Description
3-401-068-	H12	SPRING, rec. & playback head adjusting	0-027-220-	Q19	PAPER WASHER 5φ, capstan & fast forward idler
3-402-788-	H13	TAPE GUARD	-221-	Q20	FIBER WASHER 6φ, rewind idler
3-409-109-	H14	SHAFT, tape guide	0-041-206-01	Q21	CUSHION, fast forward idler retainer plate
3-410-042-	H15	TAPE PAD SHIFTER	3-401-122-	Q22	SPRING, fast forward idler
3-412-078-	H16	TERMINAL STRIP, playback head; black	3-402-838-	Q23	PLATE, fast forward idler arm
-080-	H17	SPACER, erase head mounting; black	3-409-097-	Q24	PLATE, fast forward idler retainer
-121-	H18	SHIELD CASE, playback head	-102-	Q25	NYLON WASHER, fast forward idler
-137-	H19	SPRING, recording head	-210-	Q26	CUSHION, fast forward idler arm
3-413-008-	H20	PLATE, playback head height adjusting	3-412-145-	Q27	SPRING, capstan & rewind idler
-075-	H21	TAPE GUIDE (RIGHT)	3-419-045-	Q28	PUSH ROD, capstan idler controlling
		N. CAPSTAN & FLYWHEEL MECHANISM	-211-	Q29	NYLON CAP, capstan idler
			-221-	Q30	FELT WASHER, oil retainer
X-37010-11-1	N1	CAPSTAN SHAFT ASS'Y			S. SPEED SELECTOR MECHANISM
0-027-036-	N2	SUPPORT, capstan shaft holder	0-027-131-	S1	SHAFT, speed selector
-038-	N3	RING CAP, capstan shaft holder	-198-	S2	SPRING, speed selector shaft
-155-	N4	HOLDER, capstan shaft	0-037-247-	S3	PIN, speed selector shaft
-170-	N5	SET SCREW, motor pulley	-248-	S4	WASHER, speed selector shaft
-230-	N6	METAL RING, oil retainer	3-428-109-	S5	LEVER, speed equalizer switch controlling
-250-	N7	OIL RING, capstan shaft holder		S6	BRACKET, speed equalizer switch holding
-483-05	N8 (A)	CAPSTAN 50 c/s	-110-	S7	SPACER, speed equalizer switch control lever
-483-06	N8 (B)	CAPSTAN 60 c/s			T. REEL TABLE BLOCK
0-037-029-20	N9	PULLEY, motor	3-401-088-		
-220-02	N10	SET SCREW, capstan			
3-103-139-	N11	HUM-BUCK RING, motor	X-00270-39-2	T1	FRICITION DISC, feed reel
-140-	N12	SUPPORT, hum-buck ring	3-409-246-	T1-1	FELT, friction disc
3-409-101-	N13	NYLON WASHER, capstan shaft	X-34090-37-	T2	TAKE-UP SPINDLE DRUM ASS'Y
-162-	N14	OIL ABSORBER, capstan shaft	3-409-218-	T2-1	FELT, friction
		P. PINCH ROLLER MECHANISM	0-027-245-	T2-2	FELT, rewind tension
			-247-	T2-3	FELT, oil absorber
X-34190-11-	P1	PINCH LEVER ASS'Y	X-34090-48-1	T3	FEED REEL TABLE ASS'Y
0-027-181-	P2	METAL RING, pinch roller	X-34090-29-8	T3-1	FEED REEL TABLE, top part
-193-	P3	SPRING, pinch lever	3-402-808-	T3-2	FEED REEL TABLE, middle part
-479-	P4	OIL RING, pinch roller	-812-	T3-3	FEED REEL TABLE, lower part
3-403-425-	P5	COVERING PLATE, pinch roller	-837-	T3-4	THRUST WASHER
0-027-476-	P6 (A)	PINCH ROLLER 50 c/s	3-403-467-	T3-5	FELT, friction
-477-	P6 (B)	PINCH ROLLER 60 c/s	0-027-208-	T3-6	SPRING, friction
		Q. IDLER MECHANISM	7-624-112-01	T3-7	RETAINING RING E-8
X-00270-03-	Q1	CAPSTAN IDLER ASS'Y	X-34090-49-1	T4	TAKE-UP REEL TABLE ASS'Y
X-00270-09-	Q2	ARM, rewind idler; left	X-34090-29-8	T4-1	TAKE-UP REEL TABLE, top part
X-00270-10-	Q3	SHAFT, rewind idler; right	3-402-808-	T4-2	TAKE-UP REEL TABLE, middle part
X-00270-19-0	Q4	FAST FORWARD IDLER ASS'Y	-812-	T4-3	TAKE-UP REEL TABLE, lower part
X-00270-25-	Q5	REWIND IDLER ASS'Y	-837-	T4-4	THRUST WASHER
0-027-472-01	Q5-1	TIRE, black	3-403-467-	T4-5	FELT, friction
X-00370-05-5	Q6	ARM, capstan idler	0-027-301-	T4-6	SPRING, friction
X-34090-21-	Q7	ARM, fast forward idler	7-624-112-01	T4-7	RETAINING RING E-8
3-428-121-	Q8	ROD, fast forward idler controlling	0-027-022-	T5	FRICITION DISC, take-up reel
-126-	Q9	PUSH ROD, rewind idler controlling	-119-	T6	SHAFT, take-up reel table
-127-	Q10	PULL ROD, fast forward idler controlling	-120-	T7	SHAFT, feed reel table
			-121-	T8	SPACER, feed reel table
-128-	Q11	SPRING, fast forward idler arm (horizontal use)	-180-03	T9	SPACER, take-up reel table
0-027-019-	Q12	BRACKET, rewind idler guide	3-408-069-	T10	FELT WASHER, take-up spindle drum
-020-	Q13	BRACKET, fast forward idler guide	3-409-201-	T11	NYLON SPACER, take-up & feed reel
-035-	Q14	WASHER 5φ, fast forward idler	-202-	T12	METAL SPACER, take-up & feed reel
-194-	Q15	SPRING, rewind idler arm; left	3-419-096-	T13	WASHER, take-up & feed reel
-197-	Q16	SPRING, capstan idler arm			
-215-	Q17	FELT, fast forward idler			
-216-	Q18	OIL RING 5φ, capstan & fast forward idler			

Parts List

Part No.	Symbol	Description	Part No.	Symbol	Description
		U. RECORDING MECHANISM			SCREW, MACHINE ; pan head phill. 4 × 8
X-34280-04-	U1	LEVER, rec/playback selector switch controlling	7-628-268-55		4 × 8
-05-	U2	BRACKET, rec/playback selector switch holding	-268-53		4 × 10
X-34190-07-	U3	MUTING SWITCH	-268-65		4 × 12
-13-	U4	BRACKET, recording shaft stopper	-268-75		4 × 20
7-621-259-	U5	SET SCREW, recording shaft stopper bracket	-269-25		SCREW, MACHINE ; truss head phill. 3 × 8
3-428-107-	U6	LEVER, record setting	7-621-461-57		SCREW, MACHINE ; binding head phill. 3 × 6
-108-	U7	BRACKET, rec/playback selector switch holding	-770-25		3 × 8
-122-	U8	SHAFT, recording	-770-71		SCREW, MACHINE ; flat head phill. 2 × 6
-130-	U9	SPRING, rec/playback selector switch control lever			2 × 16
-131-	U10	SPRING, record setting lever	-555-42		SCREW, MACHINE ; set 2.6 × 6 " " 3 × 5
-136-	U11	WASHER, recording shaft stopper bracket retainer	-556-02		WASHER, spring 2φ
0-041-013-	U12	SPRING, record lever	-712-57		" " 2.6φ
7-623-108-12	U13	WASHER 3φ, recording button	-713-38		" " 3φ
		W. AUTOMATIC SHUT-OFF ACTUATOR	7-623-205-22		" " 4φ
X-34120-17-	W1	AUTOMATIC SHUT-OFF ACTUATOR ASS'Y	-207-22		WASHER, plain 2φ
3-428-104-	W2	LEVER, automatic shut-off actuator cam	-208-22		" " (large) 2φ
-123-	W3	PULL ROD, automatic shut-off actuator lever	-210-22		" " 3φ
-129-	W4	PULL LEVER, automatic shut-off actuator control	-105-12		" " (large) 3φ
0-037-249-	W5	SPLIT NUT 2φ, pull rod	-105-22		" " 4φ
0-041-040-	W6	SPACER, automatic shut-off actuator control pull lever	-107-12		" " (large) 5φ
3-401-122-	W7	SPRING, automatic shut-off actuator cam lever	-108-12		" " 6φ
3-419-026-	W8	PULL LEVER, automatic shut-off actuator control	-108-22		WASHER, ext. tooth 3φ
3-419-078-	W9	CAM, automatic shut-off actuator	-110-12		RETAINING RING, E type 3φ
		Y. SCREWS, WASHERS & MISCELLANEOUS	-112-22		" " 5φ
7-621-255-15		SCREW, MACHINE ; pan head phill. 2 × 3	-113-12		NUT 3φ
-256-85		2 × 7	-408-05		" 4φ
-255-53		2 × 8	7-624-106-01		NUT, lock 3φ
-255-65		2 × 10	-109-01		SOLDER LUG 3φ
-255-75		2 × 12	7-622-108-02		
-259-15		2.6 × 3	-110-02		
-259-25		2.6 × 4	-208-02		
-259-45		2.6 × 6	7-623-508-01		
-261-15		3 × 3			
-261-25		3 × 4			
-261-35		3 × 5			
-261-43		3 × 6			
-261-45		3 × 6			
-261-55		3 × 8			
-261-56		3 × 8			
-261-65		3 × 10			
-261-75		3 × 12			
-261-85		3 × 14			
-268-45		4 × 6			
					Z. ACCESSORIES & PACKING MATERIALS
			3-790-225-11	Z1	INSTRUCTION MANUAL
			3-793-009-11	Z2	INSPECTION TAG
			8-860-007-00	Z3	REEL R-7A
			1-534-049-01	Z4	CONNECTION CORD RK-56
			3-103-191-00	Z5	POLYETHYLENE BAG
			3-401-193-02	Z6	HEAD CLEANING RIBBON
			3-793-010-20	Z7	TAPE TALK
			0-027-483-05	Z8 (A)	CAPSTAN 50 c/s
			-483-06	Z8 (B)	" 60 c/s
			0-041-127-01	Z9	ACCESSORY BAG
			0-027-476-01	Z10 (A)	PINCH ROLLER 50 c/s
			-477-01	Z10 (B)	" 60 c/s
			3-701-020-00	Z11	CHECK SHEET BAG
			X-34090-35-1	Z12	REEL CAP
			3-428-137-01	Z13	VINYL COVER, dust-proof
			X-34280-12-2	Z14	CARTON
			3-428-702-01	Z15	LABEL, specifications
			-703-01	Z16	LABEL, back cover
			3-701-028-01	Z17 (A)	TACK LABEL 50 c/s
			-029-01	Z17 (B)	TACK LABEL 60 c/s

Parts List

Part No.	Symbol No.	Description	Part No.	Symbol No.	Description
		III. ELECTRICAL PARTS	X-34280-55-	E ₁₅	MOUNTED CIRCUIT BOARD, playback
		E. ELECTRICAL PARTS (GENERAL BLOCK)	-56-	E ₁₆	MOUNTED CIRCUIT BOARD, recording
	X ₁	TRANSISTOR 2SC292-1	-57-	E ₁₇	MOUNTED CIRCUIT BOARD, osc & power supply
	X ₂	// 2SB383-1	1-538-390-	E ₁₈	PRINTED CIRCUIT BOARD, osc & power supply
	X ₃	// 2SB383-1	-389-	E ₁₉	PRINTED CIRCUIT BOARD, recording
	X ₁₀₁	// 2SC402-5 (Low Noise)	-388-	E ₂₀	PRINTED CIRCUIT BOARD, playback
	X ₁₀₂	// 2SC402-5 (Low Noise)	1-431-038-	L ₁	DUMMY COIL 1mH
	X ₁₀₃	// 2SC402-5	-038-	L ₂	DUMMY COIL 1mH
	X ₁₀₄	// 2SC402-5 (Low Noise)	1-407-049-	L ₁₀₁	MICRO INDUCTOR 270μH
	X ₁₀₅	// 2SC402-5 (Low Noise)	1-409-038-	L ₁₀₂	TRAP COIL 1mH
	X ₁₀₆	// 2SC402-5 (Low Noise)	-049-	L ₁₀₃	MICRO INDUCTOR 270μH
	X ₁₀₇	// 2SC402-5	-049-	L ₂₀₁	MICRO INDUCTOR 270μH
	X ₁₀₈	// 2SC402-5	-038-	L ₂₀₂	TRAP COIL 1mH
	X ₁₀₉	// 2SC402-4	-049-	L ₂₀₃	MICRO INDUCTOR 270μH
	X ₂₀₁	// 2SC402-5 (Low Noise)	1-231-057-	E ₂₁	ENCAPSULATED COMPONENT 0.033μF + 120Ω 500WV
	X ₂₀₂	// 2SC402-5 (Low Noise)	1-509-064-	E ₂₂	VOLTAGE ADAPTOR
	X ₂₀₃	// 2SC402-5			C. CAPACITORS
	X ₂₀₄	// 2SC402-5			CAPACITOR,
	X ₂₀₅	// 2SC402-5 (Low Noise)	1-121-361-	C ₁	electrolytic 500μF 35WV
	X ₂₀₆	// 2SC402-5 (Low Noise)	-156-	C ₂	// 200μF 25WV
	X ₂₀₇	// 2SC402-5	1-105-673-	C ₃	mylar 0.01μF 50WV
	X ₂₀₈	// 2SC402-5	1-121-156-	C ₄	electrolytic 200μF 25WV
	X ₂₀₉	// 2SC402-4	-156-	C ₅	// 200μF 25WV
	D ₁	DIODE 5GD	-173-	C ₆	// 200μF 15WV
	D ₂	// 5GD	1-105-673-	C ₇	mylar 0.01μF 50WV
	D ₁₀₁	// 1T22A	1-129-382-	C ₈	polyethylene 0.0068μF 600WV
	D ₂₀₁	// 1T22A	1-117-005-	C ₉	metalized paper 0.1μF 250WV
82-4129-00	E ₁	RECORDING HEAD RP30-2902	1-109-082-	C ₁₀	mica 50pF 500WV
82-1242-23	E ₂	PLAYBACK HEAD PP30-4202N	1-141-010-	C ₁₁	trimmer 30~200pF
82-6629-21	E ₃	ERASE HEAD EF18-2902H	1-109-082-	C ₁₂	mica 50pF 500WV
83-2624-00	E ₄	MOTOR IC-624	1-141-010-	C ₁₃	trimmer 30~200pF
1-509-029-	CNJ	CONNECTOR, rec/P.B.	1-117-036-	C _{14, 15}	metalized 1.5+0.5μF
1-507-106-	BMJ	JACK, binaural monitor; phone	1-107-005-	C _{101, 201}	silvered mica 220pF 500WV
-053-	J _{101, 201}	JACK, microphone input; mini	1-121-121-	C _{102, 202}	electrolytic 200μF 12WV
-142-	J _{102, 202}	JACK, auxiliary input; phono	-105-	C _{103, 203}	// 10μF 10WV
-142-	J _{103, 203}	JACK, line output; phono	1-105-661-	C _{104, 204}	mylar 0.001μF 50WV
1-533-006-	E ₅	FUSE HOLDER	1-121-111-	C _{105, 205}	electrolytic 100μF 3WV
1-532-014-	E ₆	FUSE 0.8A	-051-	C _{106, 206}	// 100μF 6WV
1-534-241-	E ₇	AC POWER CORD	1-105-679-	C _{107, 207}	mylar 0.033μF 50WV
1-536-030-	E ₈	TERMINAL STRIP 2L2	1-121-061-	C _{108, 208}	electrolytic 200μF 6WV
-028-	E ₉	// 1L1	-105-	C _{109, 209}	// 10μF 10WV
1-514-219-	S ₁	SWITCH, rec/P.B.; slide	-105-	C _{110, 210}	// 10μF 10WV
-140-	S ₂	SWITCH, power on/off; push button	1-105-681-	C _{111, 211}	mylar 0.047μF 50WV
-039-	S ₃	SWITCH, automatic shut-off actuator; micro	-849-	C _{112, 212}	// 0.22μF 50WV
1-514-091-	S _{102, 202}	SWITCH, mode (source/tape selector); seesaw	1-121-051-	C _{113, 213}	electrolytic 100μF 6WV
-133-	S _{103, 203}	SWITCH, muting	-192-	C _{114, 214}	// 10μF 15WV
1-513-081-	S _{104, 204}	SWITCH, equalizer; push button	1-105-671-	C _{115, 215}	mylar 0.0068μF 50W
1-517-003-	E ₁₀	SOCKET, pilot lamp	-661-	C _{116, 216}	// 0.001μF 50WV
1-518-052-	E ₁₁	PILOT LAMP	-661-	C _{117, 217}	// 0.001μF 50WV
1-524-036-	E ₁₂	METER, volume unit	-673-	C _{118, 218}	// 0.01μF 50WV
1-441-254-	E ₁₃	TRANSFORMER, power	-665-	C _{119, 219}	// 0.0022μF 50WV
1-433-081-	E ₁₄	TRANSFORMER, bias oscillation	-665-	C _{120, 220}	// 0.0022μF 50WV
			-669-	C _{121, 221}	// 0.0047μF 50WV
			-673-	C _{122, 222}	// 0.01μF 50WV
			1-107-007-	C _{123, 223}	silvered mica 500pF 500WV
			1-121-121-	C _{124, 224}	electrolytic 200μF 12WV

Parts List

Part No.	Symbol No.	Description	Part No.	Symbol No.	Description
1-121-105-	C _{125, 225}	electrolytic 10 μ F 10WV	1-240-493-	R _{117, 217}	carbon 6.8K Ω RD $\frac{3}{8}$ US
1-105-661-	C _{126, 226}	mylar 0.001 μ F 50WV	-519-	R _{118, 218}	// 82K Ω //
-845-	C _{127, 227}	// 0.1 μ F 50WV	-461-	R _{119, 219}	// 330 Ω //
1-121-111-	C _{128, 228}	electrolytic 100 μ F 3WV	-461-	R _{120, 220}	// 330 Ω //
-061-	C _{129, 229}	// 200 μ F 6WV	-499-	R _{121, 221}	// 12K Ω //
-105-	C _{130, 230}	// 10 μ F 10WV	-505-	R _{122, 222}	// 22K Ω //
1-105-679-	C _{131, 231}	mylar 0.033 μ F 50WV	-511-	R _{123, 223}	// 39K Ω //
1-121-105-	C _{132, 232}	electrolytic 10 μ F 10WV	-495-	R _{124, 224}	// 8.2K Ω //
1-105-661-	C _{133, 233}	mylar 0.001 μ F 50WV	-471-	R _{125, 225}	// 820 Ω //
-679-	C _{134, 234}	// 0.033 μ F 50WV	-473-	R _{126, 226}	// 1K Ω //
1-121-051-	C _{135, 235}	electrolytic 100 μ F 6WV	-493-	R _{127, 227}	// 6.8K Ω //
-174-	C _{136, 236}	// 1 μ F 15WV	-493-	R _{128, 228}	// 6.8K Ω //
-174-	C _{137, 237}	// 1 μ F 15WV	-487-	R _{129, 229}	// 3.9K Ω //
-117-	C _{138, 238}	// 5 μ F 12WV	-493-	R _{130, 230}	// 6.8K Ω //
1-105-823-	C _{140, 240}	mylar 0.0015 μ F 50WV	-493-	R _{131, 231}	// 6.8K Ω //
-665-	C _{141, 241}	// 0.0022 μ F 50WV	-493-	R _{132, 232}	// 6.8K Ω //
R. RESISTORS					
RESISTOR,					
1-201-816-	R ₁	composition 47 Ω RC1	1-209-909-	R _{138, 238}	// 10K Ω RD $\frac{3}{4}$ UR
1-242-657-	R ₂	carbon 220 Ω RD $\frac{3}{4}$ UR	-908-	R _{139, 239}	// 47K Ω //
-633-	R ₃	// 22 Ω //	1-240-503-	R _{140, 240}	// 18K Ω RD $\frac{3}{8}$ US
1-201-815-	R ₄	composition 390 Ω RC1	-487-	R _{141, 241}	// 3.9K Ω //
-470-	R ₅	// 470 Ω RC $\frac{1}{2}$	1-221-311-	R _{142, 242}	adjustable 5K Ω (B)
1-242-705-	R ₆	carbon 22K Ω RD $\frac{3}{4}$ UR	1-240-483-	R _{143, 243}	carbon 2.7K Ω RD $\frac{3}{8}$ US
-675-	R ₇	// 1.2K Ω //	-493-	R _{144, 244}	// 6.8K Ω //
1-221-640-	R ₈	VOLUME CONTROL, sound on sound 100K Ω	-521-	R _{145, 245}	// 100K Ω //
RESISTOR,					
1-244-721-	R _{101, 201}	carbon 100K Ω RD $\frac{3}{4}$ SR	-499-	R _{146, 246}	// 12K Ω //
1-201-237-	R _{102, 202}	composition 2.7K Ω RC $\frac{1}{4}$	1-221-383-	R _{147, 247}	adjustable 10K Ω (B)
1-244-743-	R _{103, 203}	carbon 820K Ω RD $\frac{3}{4}$ SR	1-240-519-	R _{148, 248}	carbon 82K Ω RD $\frac{3}{8}$ US
-725-	R _{104, 204}	// 150K Ω //	-493-	R _{149, 249}	// 6.8K Ω //
1-240-441-	R _{105, 205}	// 47 Ω RD $\frac{3}{8}$ US	-519-	R _{150, 250}	// 82K Ω //
1-209-909-	R _{106, 206}	// 10K Ω RD $\frac{3}{4}$ UR	-461-	R _{151, 251}	// 330 Ω //
-908-	R _{107, 207}	// 47K Ω //	-499-	R _{152, 252}	// 12K Ω //
1-221-641-	R _{108, 208}	VOLUME CONTROL, recording 10K Ω	-509-	R _{153, 253}	// 33K Ω //
RESISTOR,					
1-240-503-	R _{109, 209}	carbon 18K Ω RD $\frac{3}{8}$ US	-495-	R _{154, 254}	// 8.2K Ω //
-483-	R _{110, 210}	// 2.7K Ω //	-511-	R _{155, 255}	// 39K Ω //
-493-	R _{111, 211}	// 6.8K Ω //	-471-	R _{156, 256}	// 820 Ω //
-507-	R _{112, 212}	// 27K Ω //	-473-	R _{157, 257}	// 1K Ω //
1-221-383-	R _{113, 213}	adjustable 10K Ω (B)	1-221-629-	R _{158, 258}	adjustable 50K Ω (B)
1-240-509-	R ₁₁₄	carbon 33K Ω RD $\frac{3}{8}$ US	1-240-537-	R _{159, 259}	carbon 470K Ω RD $\frac{3}{8}$ US
1-221-383-	R _{115, 215}	adjustable 10K Ω (B)	-477-	R _{160, 260}	// 1.5K Ω //
1-240-487-	R _{116, 216}	carbon 3.9K Ω RD $\frac{3}{8}$ US	-477-	R _{161, 261}	// 1.5K Ω //
RESISTOR,					
1-244-697-	R _{163, 263}	// 10K Ω RD $\frac{3}{4}$ SR	1-244-697-	R _{163, 263}	// 10K Ω RD $\frac{3}{4}$ SR
1-240-537-	R _{164, 264}	// 470K Ω RD $\frac{3}{8}$ US	1-240-537-	R _{164, 264}	// 470K Ω RD $\frac{3}{8}$ US

Exploded Diagram

(1)

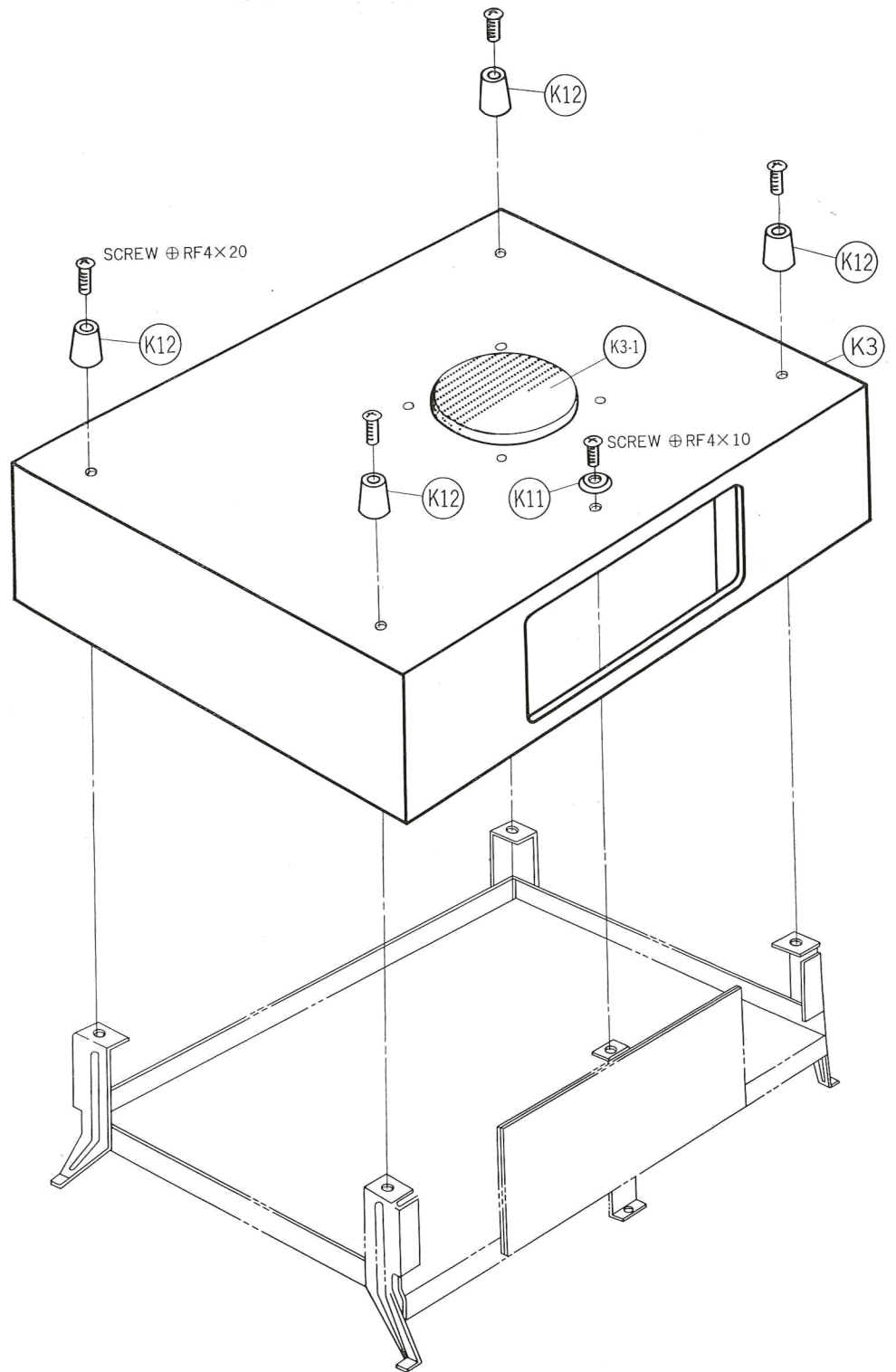

Exploded Diagram

(3)

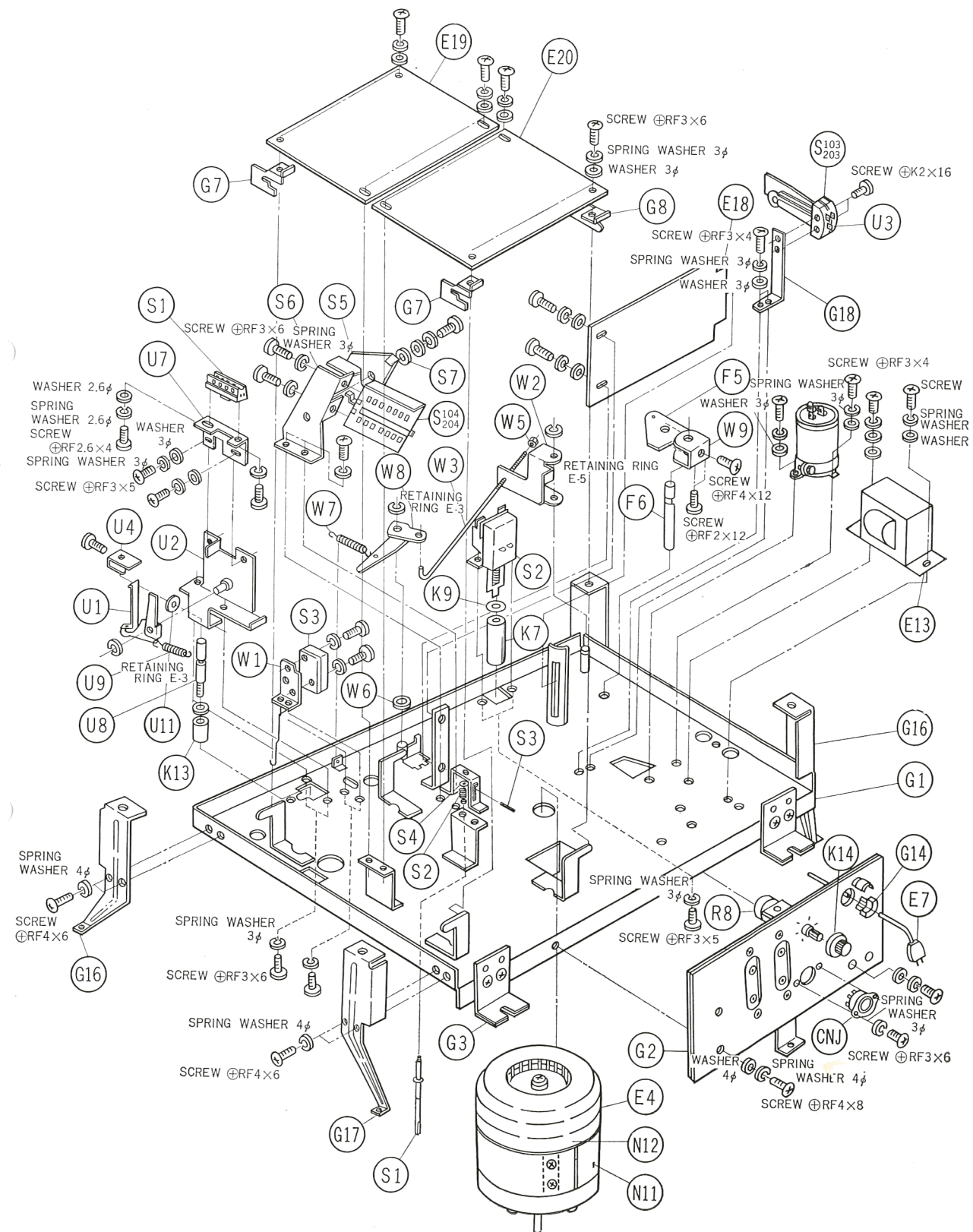

Exploded Diagram

(4)

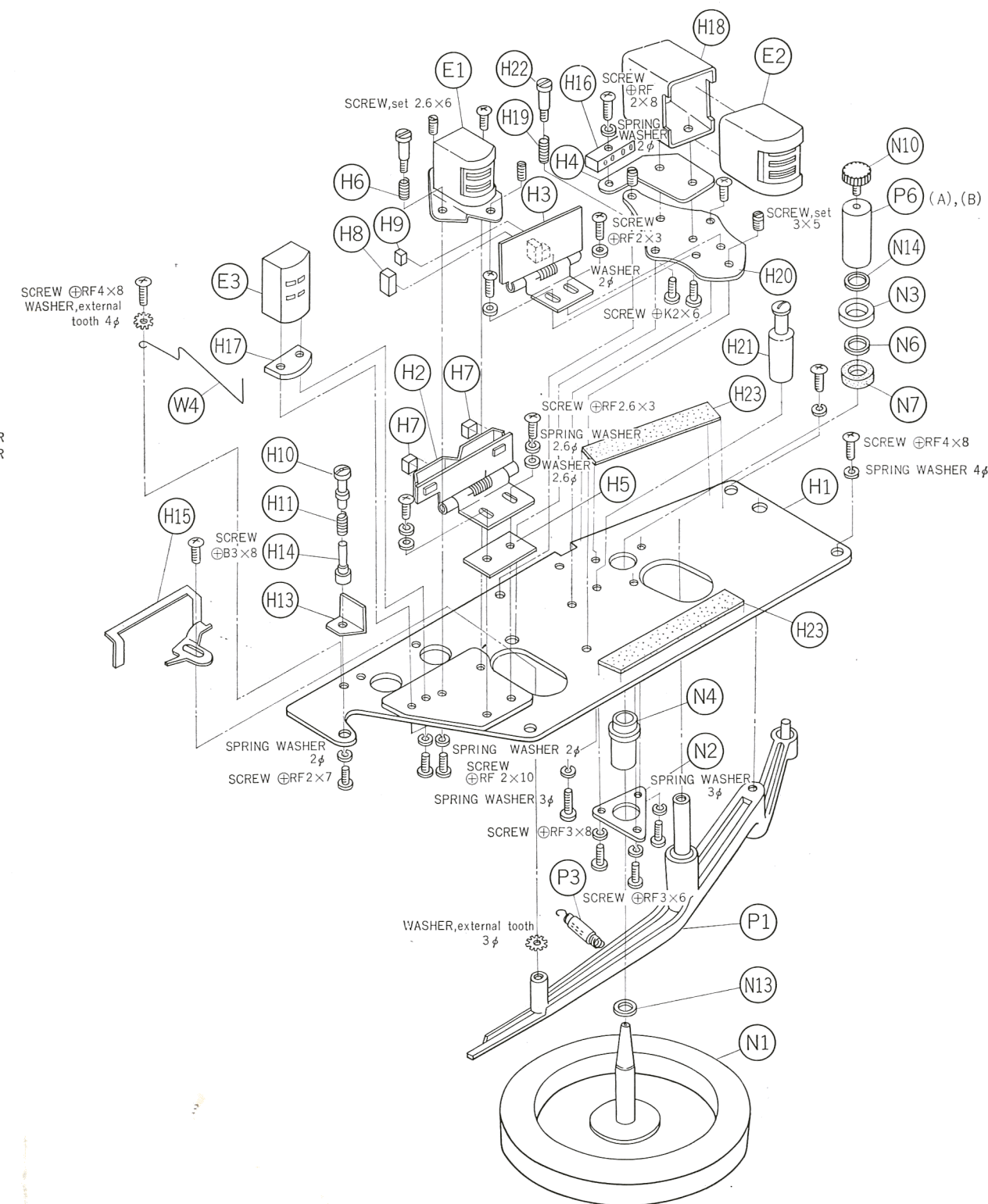

Exploded Diagram
(5)

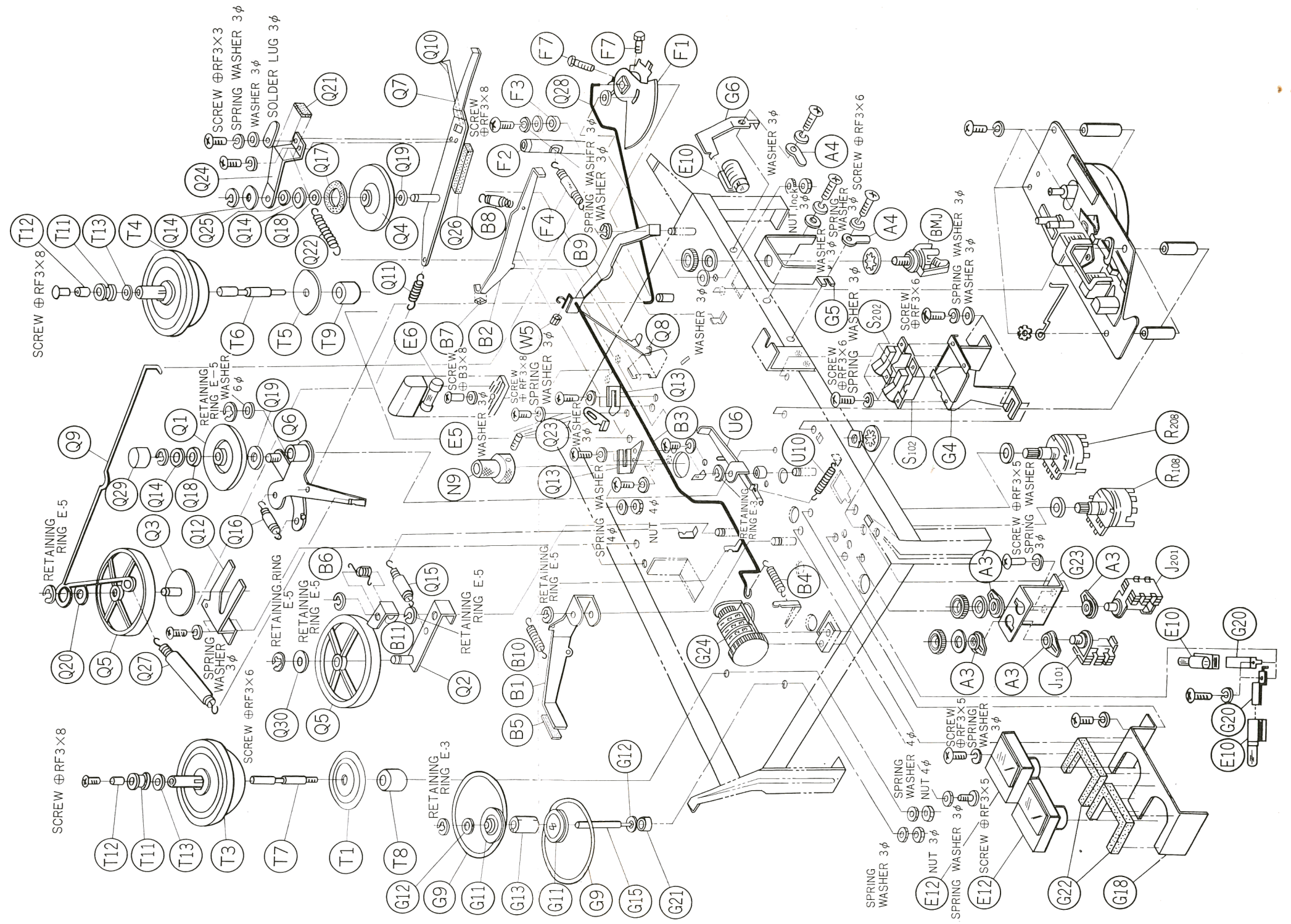

SONY CORPORATION

Circuit Schematic

—Power Supply Section for U. S. A.—

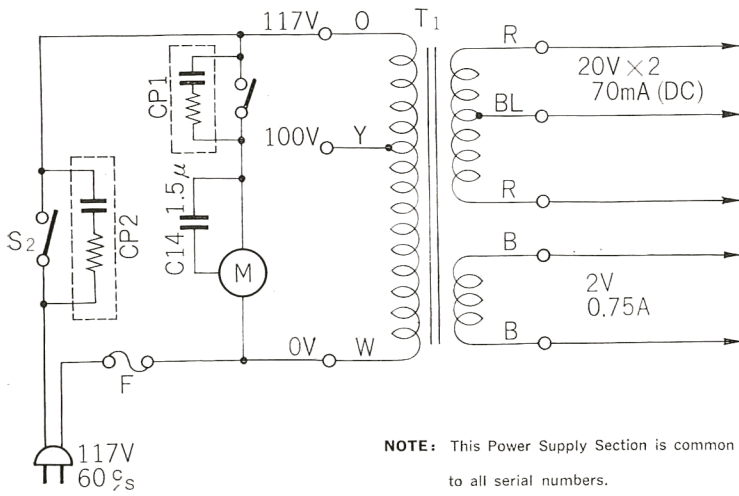

NOTE: This Power Supply Section is common to all serial numbers.

Parts List for U. S. A. (additional)

Ref. No.	Part No.	Description	Q'ty
	X-34038-05-	PINCH ROLLER ASS'Y, strobo disk	1
	3-422-204-03	CAUTION LABEL	1
	3-793-011-	CHECK SHEET	1
	-016-	INSTRUCTION MANUAL, strobo disk	1
	-030-	BOOKLET, SONY tape	1
	3-716-111-11	INSPECTION CARD	1
	X-37010-08-1	HEAD CLEANING RIBBON ASS'Y	1
	3-154-330-11	CORD w/plug, UL	1
	1-441-236-12	TRANSFORMER, power T ₁	1
	1-117-035-22	CAPACITOR, metalized C ₁₄	1

