

TC-366-4

E Model



SPECIFICATIONS

Power Requirements:	AC 100, 110, 117, 125, 220, 240V, 40W, 50/60 Hz	Inputs:	Four MIC inputs Impedance: 600 Ω Maximum sensitivity: 0.19 mV (-72 dB)									
Track System:	Four-track, four-channel stereo		Four AUX INputs Impedance: 100 k Ω Maximum sensitivity: 0.06V (-22 dB)									
Reel Size:	7" maximum	Outputs:	Four LINE OUTputs Impedance: 100 k Ω Output level: 0.775V (0 dB)									
Tape Speed:	7 $\frac{1}{2}$ ips and 3 $\frac{3}{4}$ ips (19 cm/s and 9.5 cm/s)		Two HEADPHONE outputs Impedance: 8 Ω Output level: 30 mV (-28 dB)									
Recording Time: (with 1,800 ft tape)	<table><thead><tr><th>Tape speed</th><th>4-channel stereo</th><th>2-channel stereo</th></tr></thead><tbody><tr><td>7$\frac{1}{2}$ ips (19 cm/s)</td><td>45 min.</td><td>1.5 hrs</td></tr><tr><td>3$\frac{3}{4}$ ips (9.5 cm/s)</td><td>1.5 hrs</td><td>3 hrs</td></tr></tbody></table>	Tape speed	4-channel stereo	2-channel stereo	7 $\frac{1}{2}$ ips (19 cm/s)	45 min.	1.5 hrs	3 $\frac{3}{4}$ ips (9.5 cm/s)	1.5 hrs	3 hrs	Semiconductors:	49 transistors and 6 diodes
Tape speed	4-channel stereo	2-channel stereo										
7 $\frac{1}{2}$ ips (19 cm/s)	45 min.	1.5 hrs										
3 $\frac{3}{4}$ ips (9.5 cm/s)	1.5 hrs	3 hrs										
Frequency Response:	20~25,000 Hz at 7 $\frac{1}{2}$ ips (19 cm/s) 30~17,000 Hz at 3 $\frac{3}{4}$ ips (9.5 cm/s)	Dimensions:	16 $\frac{31}{32}$ " (W) x 18 $\frac{25}{32}$ " (H) x 9 $\frac{39}{64}$ " (D) (431 x 477 x 244 mm)									
Signal-to-Noise Ratio:	Normal 52 dB, Special 55 dB	Weight:	28 lb 3 oz (12.8 kg)									
Flutter and Wow:	0.09% at 7 $\frac{1}{2}$ ips (19 cm/s) 0.12% at 3 $\frac{3}{4}$ ips (9.5 cm/s)											
Recording Bias Frequency:	Approx. 125 kHz											

SONY[®]
SERVICE MANUAL

TABLE OF CONTENTS

<u>Title</u>	<u>Page</u>	<u>Title</u>	<u>Page</u>
SPECIFICATIONS	1	11-2. REC & P.B. Amp. Section	31 ~ 32
1. GENERAL DESCRIPTION	2	12. LEVEL DIAGRAM	41
2. BLOCK DIAGRAM	3	13. ELECTRICAL PARTS LIST	42 ~ 45
3. CABINET - TOP VIEW -	4	14. EXPLODED VIEW	
4. CABINET - SIDE VIEW -	4	14-1. Packing	46
5. CHASSIS - TOP VIEW -	5	14-2. Cabinet - top view -	47 ~ 48
6. CHASSIS - BOTTOM VIEW -	5	14-3. Amplifier Chassis	
7. DISASSEMBLY	6	- FRONT - (1)	49 ~ 50
8. MECHANICAL ADJUSTMENT	7 ~ 15	14-4. Amplifier Chassis	
9. ELECTRICAL ADJUSTMENT	17 ~ 25	- FRONT - (2)	51 ~ 52
10. MOUNTING DIAGRAM		14-5. Amplifier Chassis	
10-1. Bias OSC Circuit Board	26 ~ 27	- REAR - (1)	53
10-2. Power Supply Circuit Board	28 ~ 29	14-6. Amplifier Chassis	
10-3. REC Amp. Circuit Board	33 ~ 36	- REAR - (2)	54
10-4. P.B. Amp. Circuit Board	37 ~ 40	14-7. Head Deck - top view -	55 ~ 56
11. SCHEMATIC DIAGRAM		14-8. Reel Table - top view -	57 ~ 58
11-1. Bias OSC & Power Supply		14-9. Mechanical Chassis View	59 ~ 60
Section	30	15. HARDWARES	61
		Hardware Nomenclature	61
		16. CONVERSION TO DIFFERENT	
		POWER LINE FREQUENCY	62

1. GENERAL DESCRIPTION

The SONY Model TC-366-4 which is the one-motor, three-head four-channel stereo deck type tape recorder, equips with the following features;

Tape Tension Regulator

The machine can operate always under the stable tape running by the tape tension regulator which quickly responds to the subtle change of tape tension, so that the tape tension regulator can reduce the wow and flutter extremely.

Automatic Shut-off Mechanism

When threading the tape, the shut-off lever is held by the threaded tape in operating position. If tape runs out or breaks, the shut-off lever swings outward and activates the automatic shut-off mechanism. As a result, the function selector knob can return to the STOP position without setting it manually.

Note: When threading the tape, make certain that there is no slack in the threaded tape, otherwise the function selector knob will not be set at the desired position.

2. BLOCK DIAGRAM

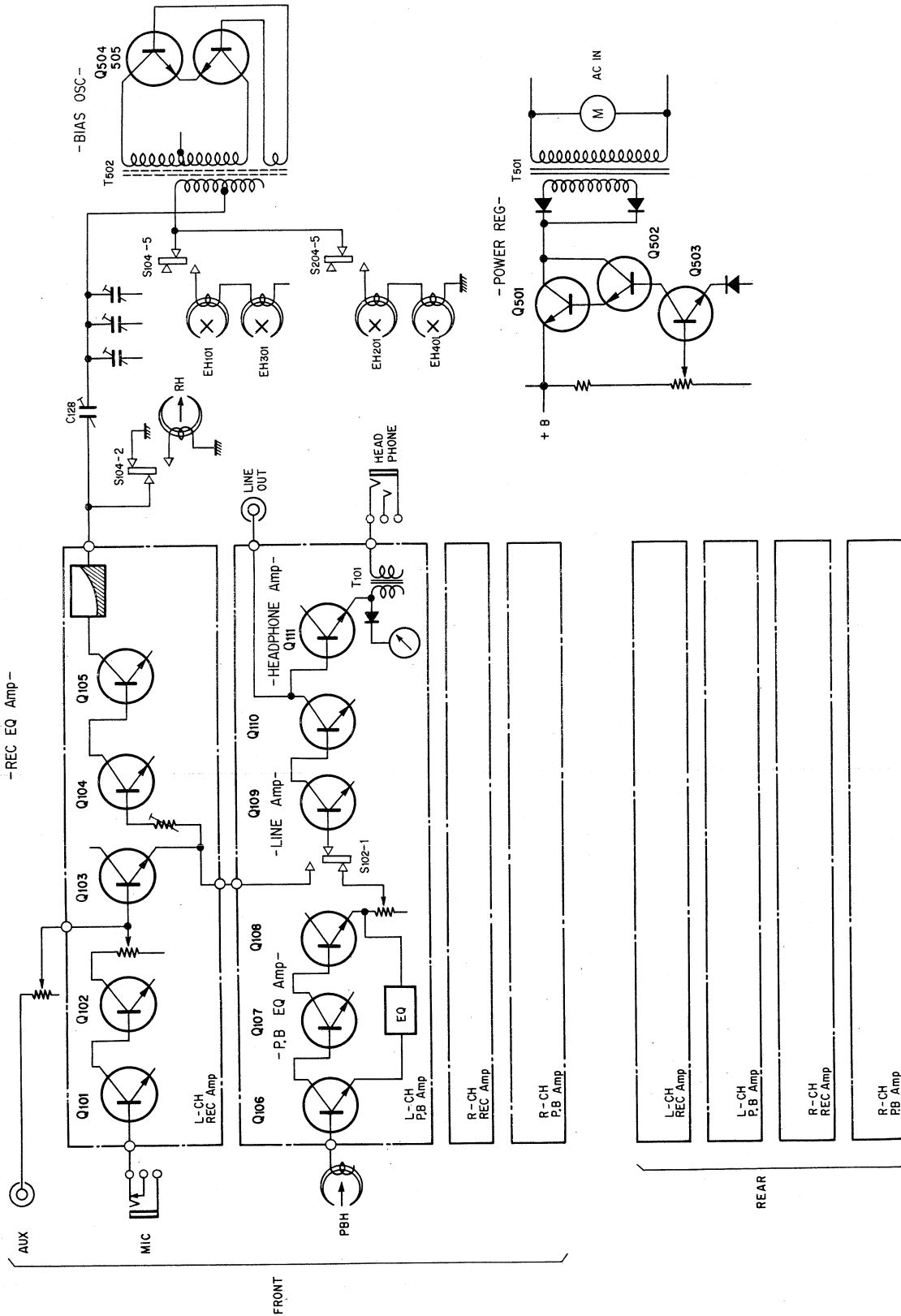

REAR channel is same as FRONT channel.

3. CABINET – TOP VIEW –

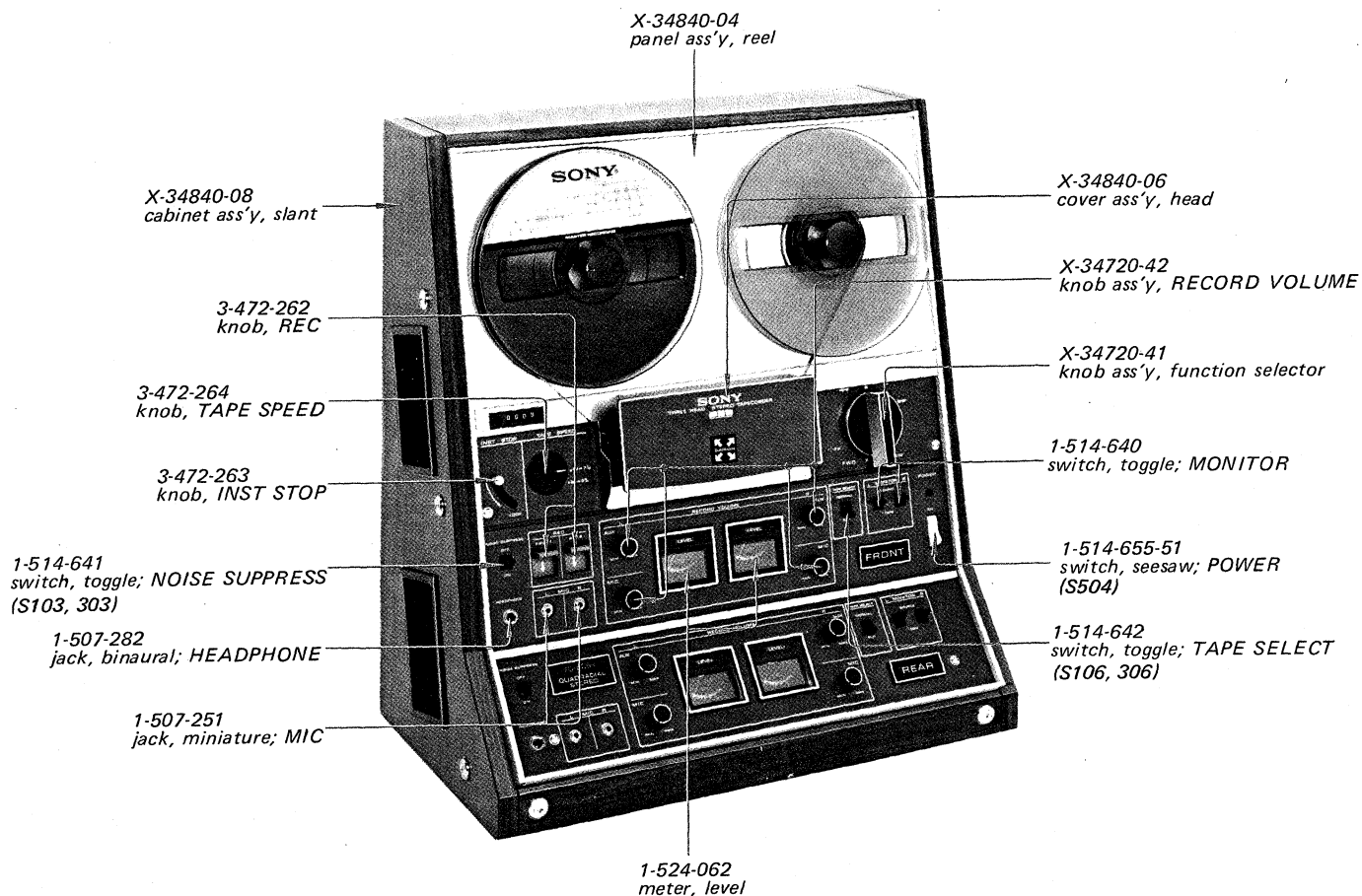

4. CABINET – SIDE VIEW –

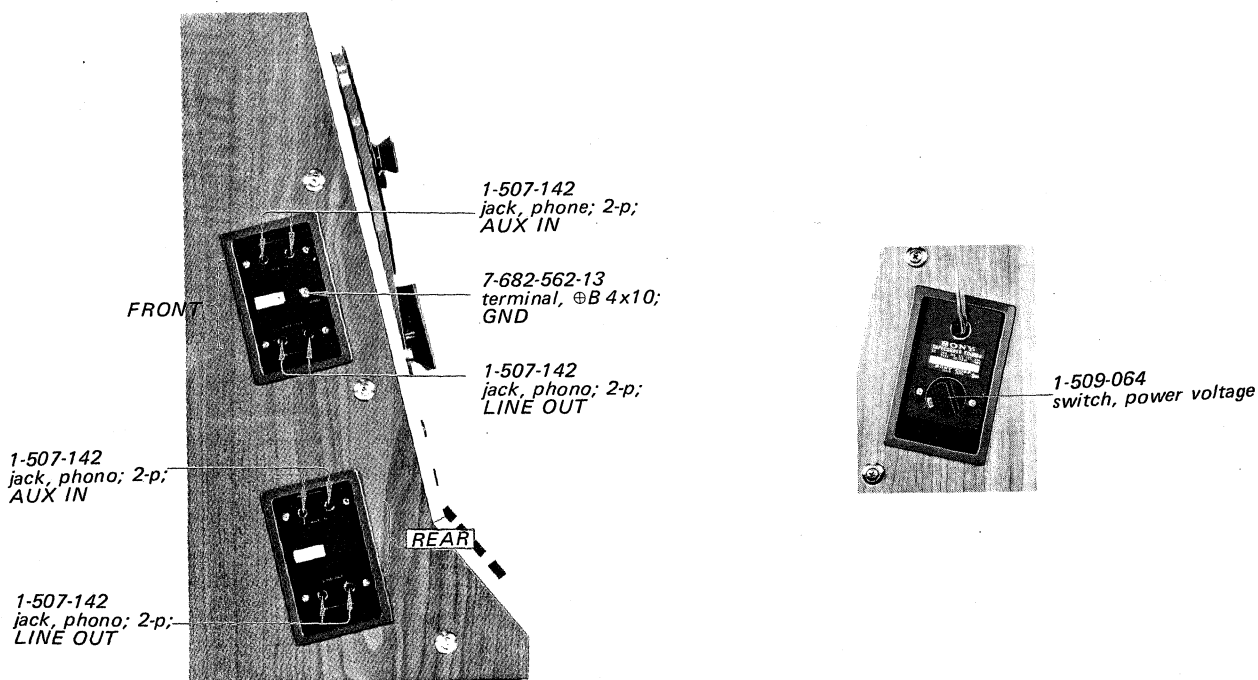

7. DISASSEMBLY

5. CHASSIS — TOP VIEW —

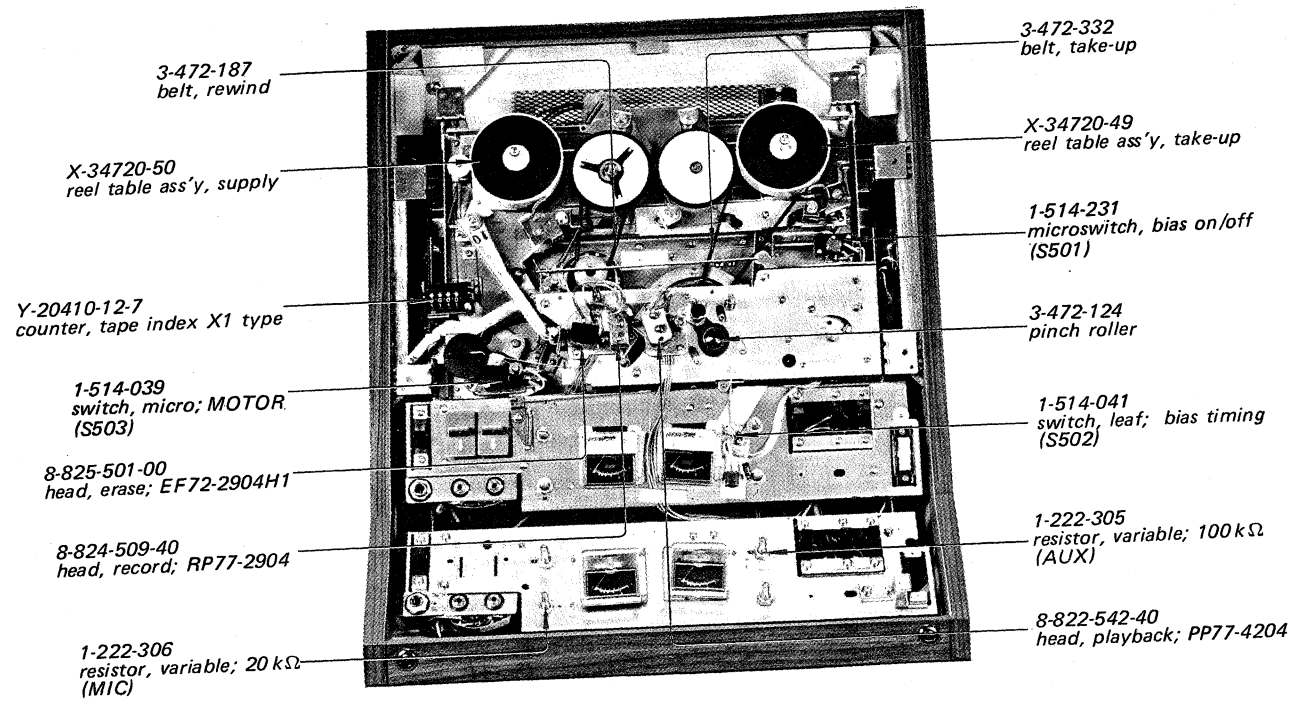

6. CHASSIS — BOTTOM VIEW —

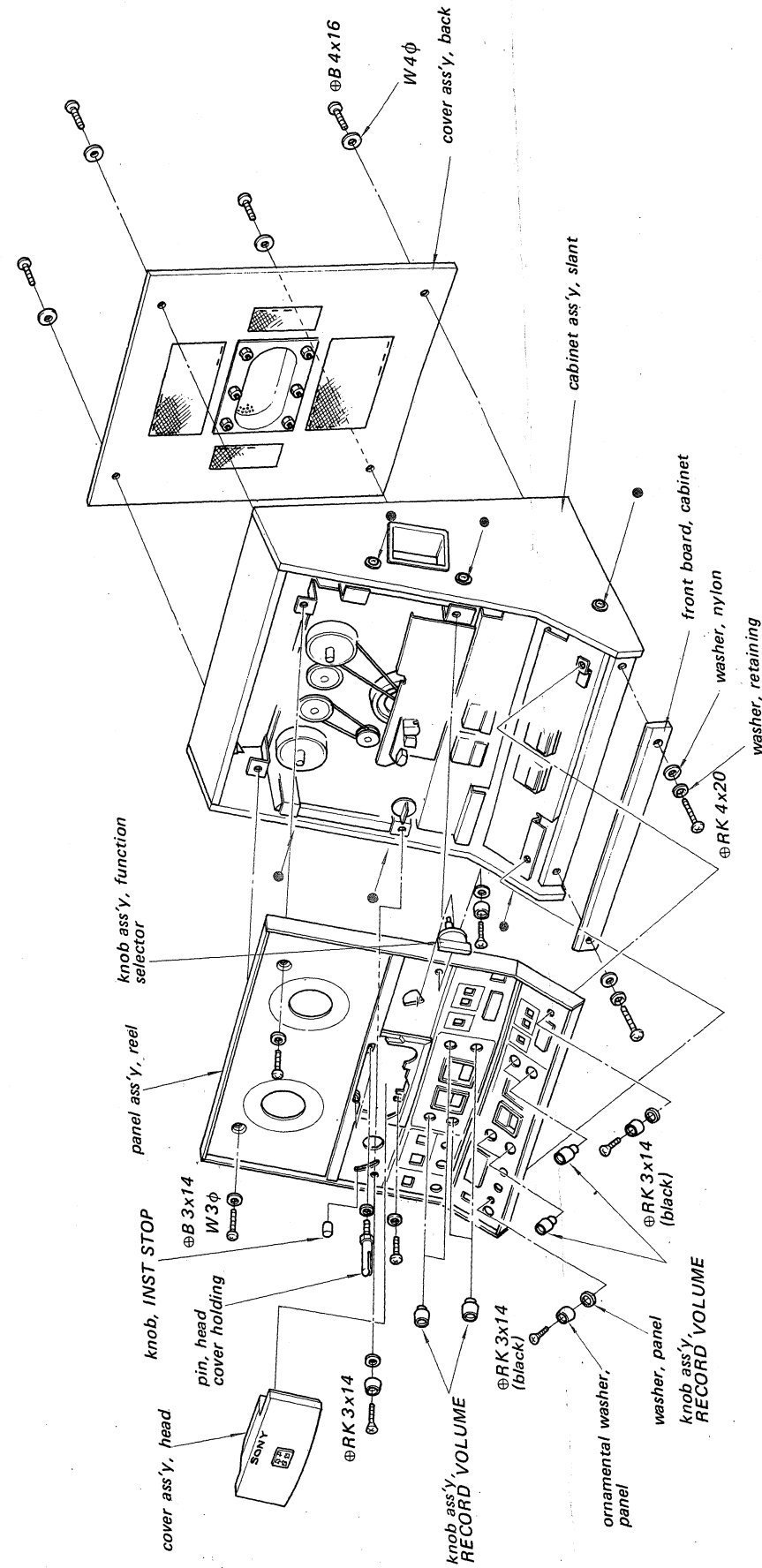
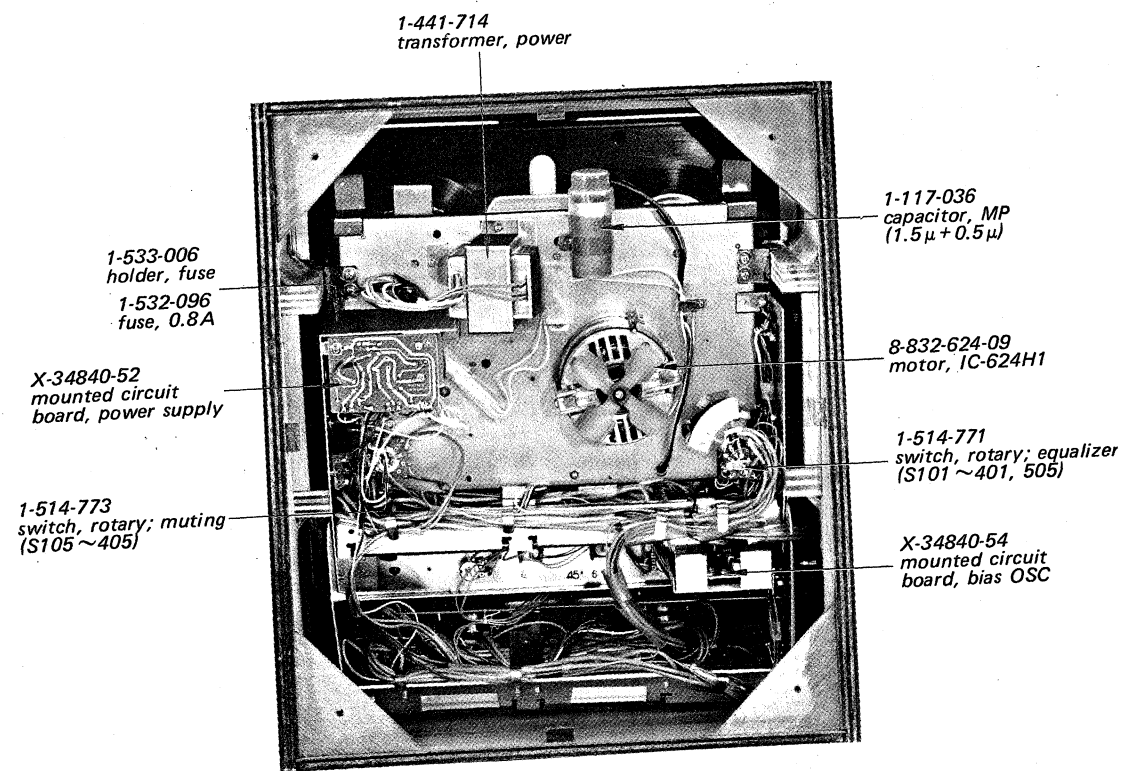

Notes:
 (1) When removing the instant stop knob, turn it clockwise.
 (2) When removing the chassis, remove the six screws (@B 4x45) marked with ●.

8. MECHANICAL ADJUSTMENT

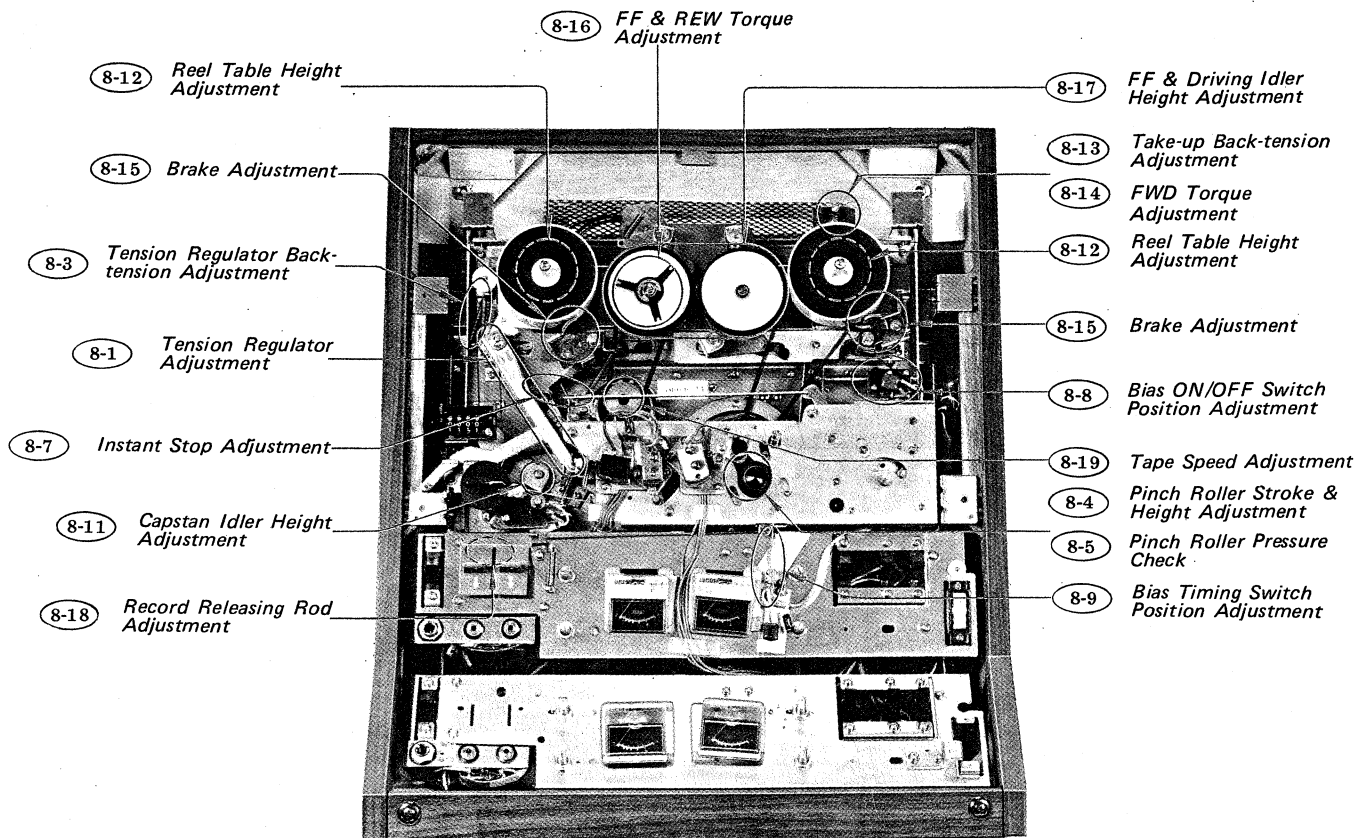

Fig. 8-1 Adjusting parts location (1)

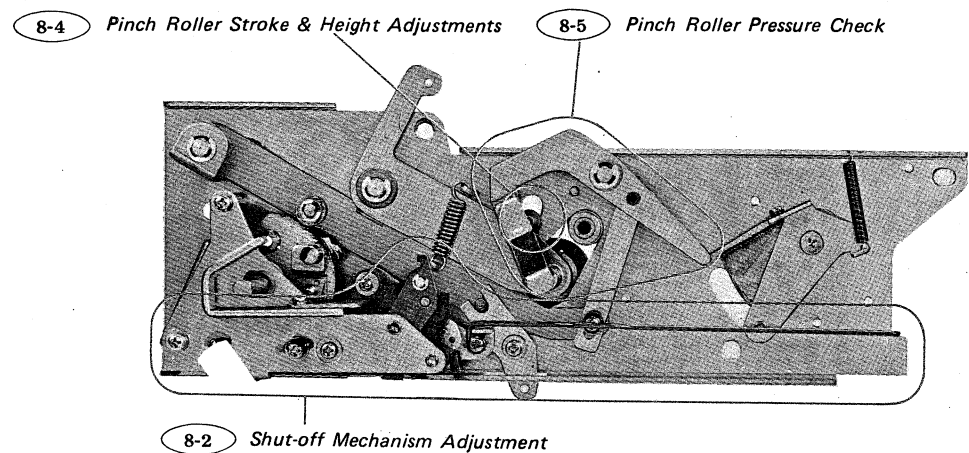

Fig. 8-2 Adjusting parts location (2)

Note: The numbers in the ellipse indicate the adjustment's title number as described in the procedure 8.

In case the parts described in the table below are reassembled or replaced, the following adjustments and checks are necessary.

Parts	Adjusting or Checking Item
Head Deck	8-7. Instant Stop Adjustment (See page 11) 8-9. Bias Timing Switch Position Adjustment (See page 11) 8-18. Record Releasing Rod Adjustment (See page 14)
Motor	8-11. Capstan Idler Height Adjustment (See page 12) 8-19. Tape Speed Adjustment (See page 15)
Reel Table	8-12. Reel Table Height Adjustment (See page 12) 8-13. Take-up Back-tension Adjustment (See page 12) 8-14. FWD Torque Adjustment (See page 12)
Driving Idler	8-16. FF & REW Torque Adjustments (See page 14) 8-17. FF & Driving Idler Height Adjustments (See page 14)
Tension Regulator Arm	8-1. Tension Regulator Adjustment (See page 8)
Tension Regulator Arm Felt	8-3. Tension Regulator Back-tension Adjustment (See page 9)

8-1. Tension Regulator Adjustment

— in STOP mode —

- (1) With the tension regulator stopper pushed in the direction shown by arrow in Fig. 8-3, adjust the adjusting screw so that the clearance shown is 7.5 ~ 8 mm ($19/64 \sim 5/16$ ") after having been turned the reel table counterclockwise by hand.
- (2) After the adjustment, apply lock paint to the screw.

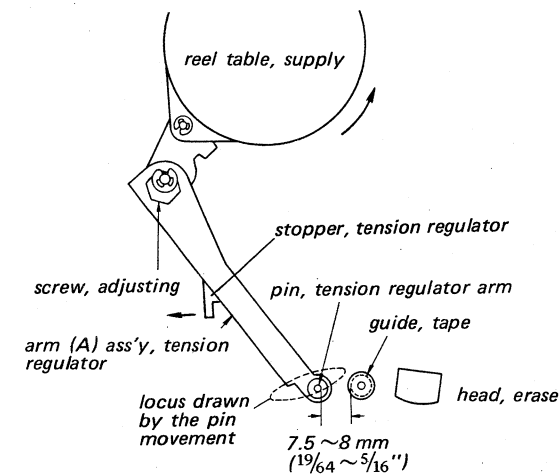
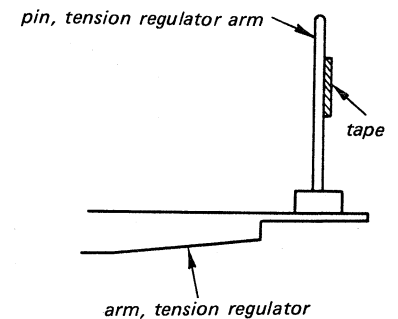

Fig. 8-3 Tension regulator adjustment



Be sure that the tape comes in contact with the tension regulator arm pin uniformly at the beginning and the end of the tape as shown. If not, adjust by bending the tension regulator arm pin.

Fig. 8-4 Tension regulator adjustment

8-2. Shut-off Mechanism Adjustment

— in STOP mode —

- (1) Loosen the two screws (A) and adjust by positioning the shut-off lever holding plate ass'y so that the shut-off mechanism is locked when the clearance between the shut-off arm and the head deck is 7 mm ($\frac{9}{32}$ "'), and the shut-off mechanism is released completely when it is 1 mm ($\frac{3}{64}$ "').
- (2) Adjust by changing the hooking position of the spring to obtain the specified values on the spring scale at the beginning and the end of the tape as shown in Fig. 8-6. If it is not obtained the specified values, adjust by bending the stud or perform the tension regulator adjustment.

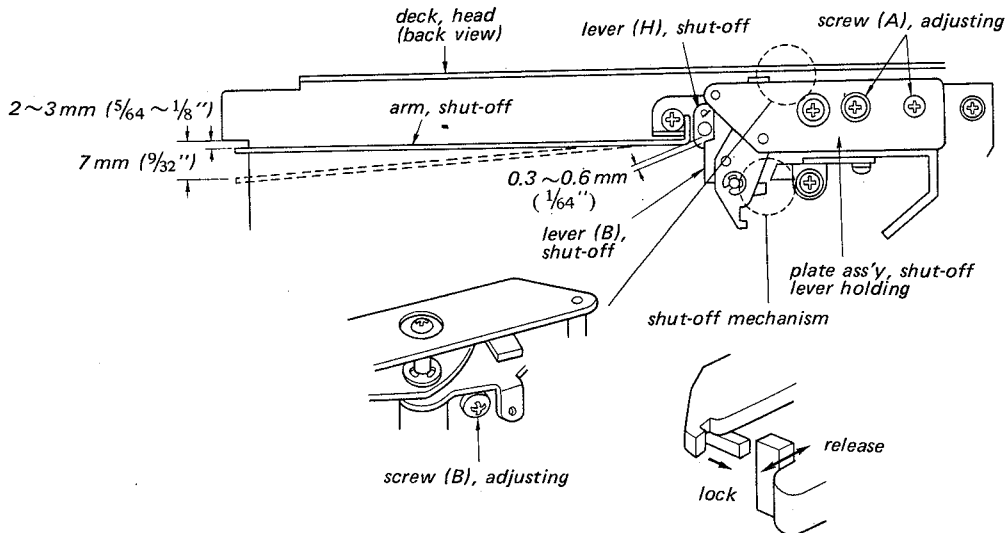

Fig. 8-5 Shut-off mechanism adjustment

- (2) Adjust the screw (B) so that the clearance between the shut-off levers (B) and (H) is 0.3~0.6 mm ($\frac{1}{64}$ "') in STOP mode.
- (3) After the adjustment, apply lock paint to the screws.

8-3. Tension Regulator Back-tension Adjustment

In FWD & FF modes

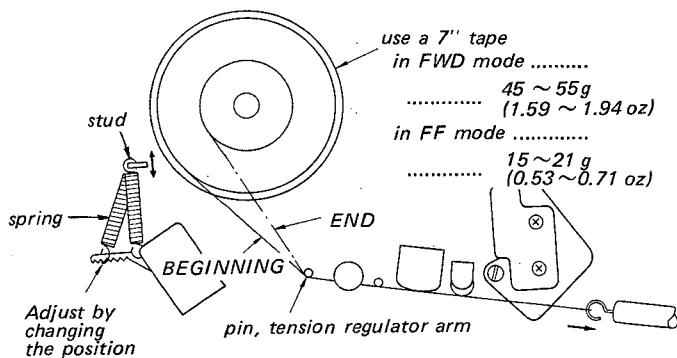

Fig. 8-6 Tension regulator back-tension adjustment

- (1) Make the tension regulator adjustment.

8-4. Pinch Roller Stroke & Height Adjustment

- (1) Remove the head deck by removing the four screws marked with \blacktriangle on page 55.
- (2) Adjust the screw ① so that the pinch roller shaft comes in contact with the retractive lever at the position (A) shown in Fig. 8-8, in STOP mode.
- (3) Fix the screw ① while pushing the lever joint in the direction shown by arrow in Fig. 8-7.

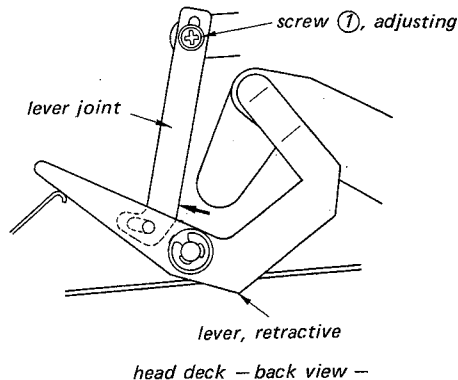

Fig. 8-7 Pinch roller stroke adjustment

- (4) Put the dummy capstan * into the capstan bearing and be sure that the pinch roller shaft moves by approx. 3 ~ 4 mm ($\frac{1}{8}$ ~ $\frac{5}{32}$ ") on the surface of the retractive lever when the function selector knob is changed from STOP to FWD.
- (5) Be sure that the washer for the pinch roller shaft does not come in contact with the part indicated with ▲ on the retractive lever shown in Fig. 8-8 when the function selector knob is changed slowly from FWD to FF.
- (6) After the adjustment, apply lock paint to the screw.

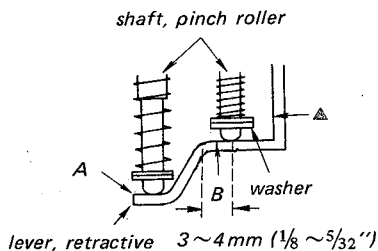

Fig. 8-8 Pinch roller stroke adjustment

- (7) Confirm that the pinch roller is as shown in Fig. 8-9.

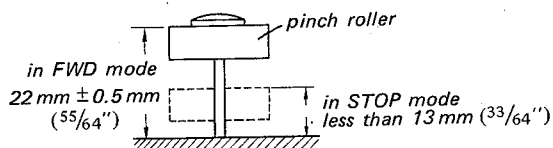

Fig. 8-9 Pinch roller height adjustment

*** Dummy Capstan**

As the pinch roller stroke adjustment and the pinch roller pressure check require the dummy capstan, make it as follows.

Prepare a flywheel ass'y (for TC-366) and remove the capstan shaft (dummy capstan) from the flywheel ass'y by patting the head of the capstan shaft with the hammer, taking care not to bend the shaft. Flywheel Ass'y

Part No.: X-34720-03

8-5. Pinch Roller Pressure Check

— in STOP mode —

- (1) Put the dummy capstan * into the capstan bearing and be sure that the clearance between the pinch levers (A) and (B) is approx. 0.5mm ($\frac{1}{64}$ ").

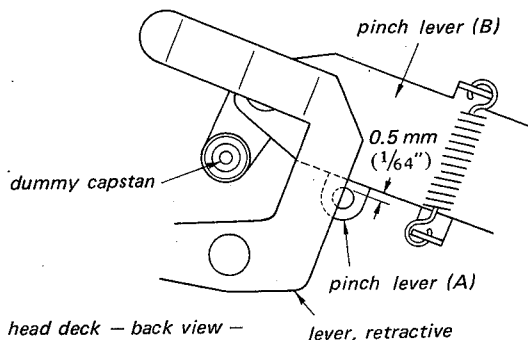

Fig. 8-10 Pinch roller pressure check

Be sure that the spring scale indicates 800 ~ 1,000 g (1 lb 12 oz ~ 2 lb 3 oz) when the pinch roller is detached from the capstan in FWD mode.

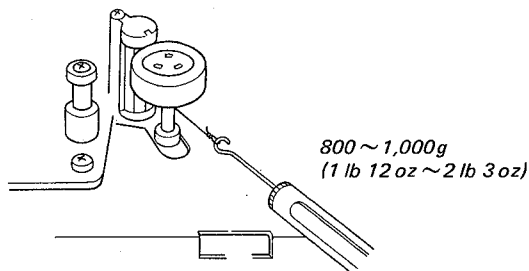

Fig. 8-11 Pinch roller pressure check

8-6. Speed Selector Cam Position Adjustment

— in FWD mode —

Adjust the screw to locate the idler arm (c) pin at the center position between the two stopper slots shown, at 19 cm/s tape speed.

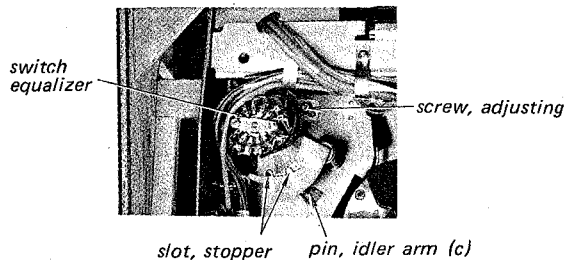

Fig. 8-12 Speed selector cam position adjustment

8-7. Instant Stop Adjustment

— in STOP mode —

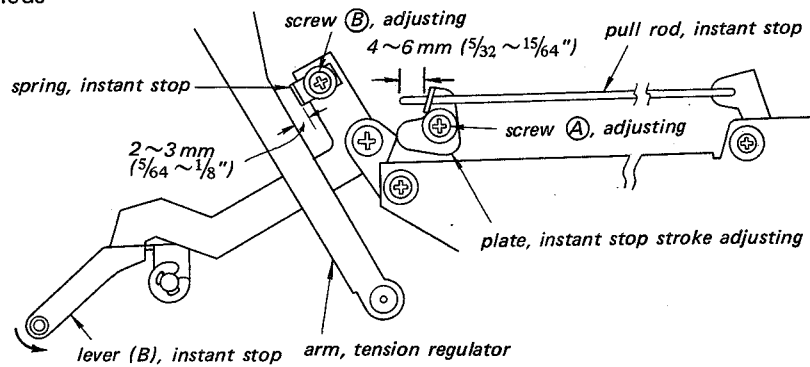

Fig. 8-13 Instant stop adjustment

- (1) Be sure that the tension regulator adjustment has been made.
- (2) Adjust the screw (A) so that the distance between the end of the instant stop pull rod and the instant stop stroke adjusting plate is 4~6 mm ($\frac{5}{32} \sim \frac{15}{64}$ ") in STOP mode.
- (3) Be sure that the clearance between the pinch roller and the capstan is more than 1 mm ($\frac{3}{64}$ ") when pulling the instant stop lever (B) in FWD mode, and the instant stop knob is not locked when pulling it in STOP mode.
- (4) Adjust the screw (B) so that the clearance between the tension regulator arm and the instant stop spring is 2~3 mm ($\frac{5}{64} \sim \frac{1}{8}$ ") in STOP mode.
- (5) After the adjustment, apply lock paint to the screws.

8-8. Bias ON/OFF Switch Position Adjustment

- (1) Loosen the two screws and adjust by positioning the switch.
- (2) Be sure that the switch is in ON position in FWD mode, and when the function selector knob is changed slowly from FWD to STOP the record knob is released after the switch is in OFF.

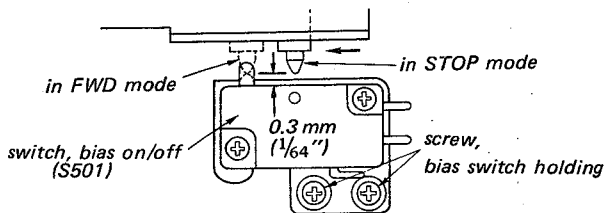

Fig. 8-14 Bias on/off switch position adjustment

8-9. Bias Timing Switch Position Adjustment

— in FWD mode —

Loosen the two screws and adjust by positioning the switch.

in modes except FWD mode: 0.5~0.7 mm ($\frac{1}{64}$ ")
in FWD mode: To contact sufficiently

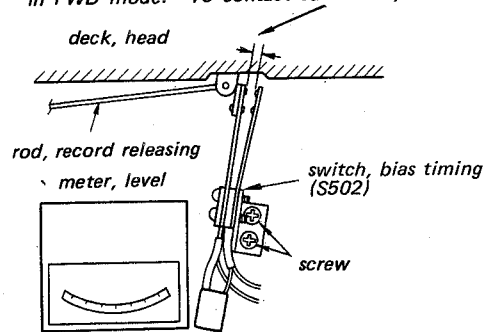

Fig. 8-15 Bias timing switch position adjustment

8-10. Idler Arm (C) Stroke Check

— in FWD mode at 9.5 cm/s ($3\frac{3}{4}$ ips) tape speed —

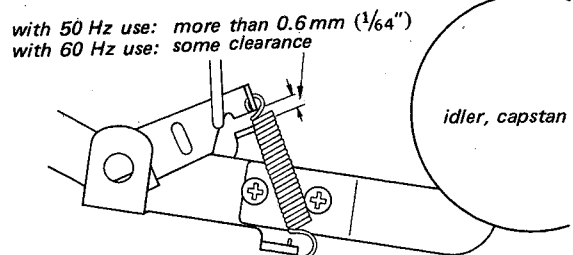

Fig. 8-16 Idler arm (C) stroke check

8-11. Capstan Idler Height Adjustment

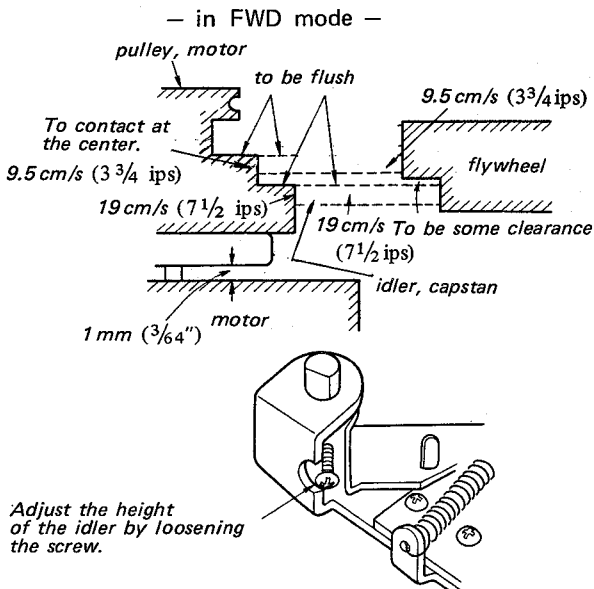

Fig. 8-17 Capstan idler height adjustment

After the adjustment, be sure that the capstan idler does not come in contact with the flywheel and the motor pulley in STOP mode with 60 Hz use and the clearance between the capstan idler and the motor pulley is more than 3 mm (1/8") in STOP mode with 50 Hz use.

8-12. Reel Table Height Adjustment

— in FWD, REW & FF modes —

- (1) Adjust the height of the reel table by loosening the screw so that the tape does not come in contact with the flange of the reel in FWD, REW & FF modes.
- (2) Perform the back-tension and FWD torque adjustments.
- (3) After the adjustment, apply lock paint to the screw.

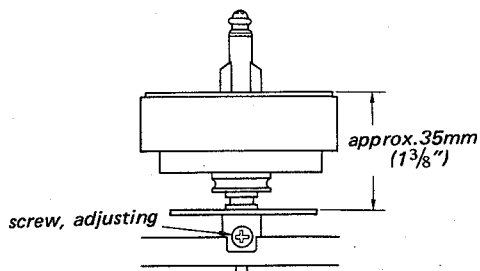

Fig. 8-18 Reel table height adjustment

8-13. Take-up Back-tension Adjustment

— in REW mode —

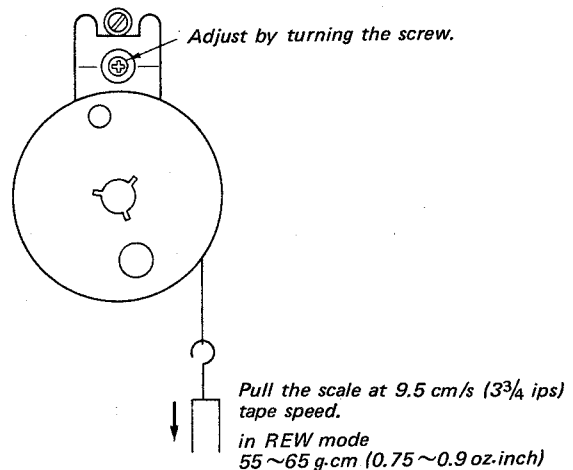

Fig. 8-19 Take-up back-tension adjustment

After the adjustment, perform the FWD torque adjustment and apply lock paint to the screw.

8-14. FWD Torque Adjustment

— in FWD mode —

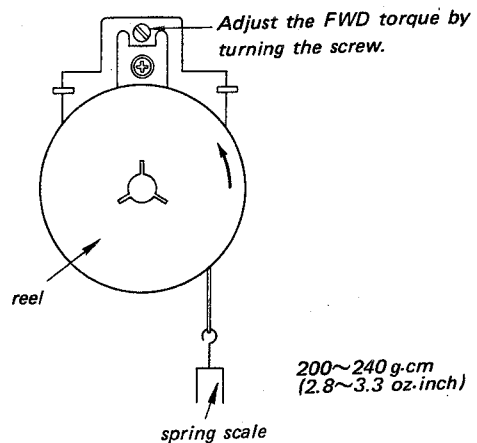

Fig. 8-20 FWD torque adjustment

After the adjustment, perform the take-up back-tension torque and apply lock paint to the screw.

8-15. Brake Adjustment

— in STOP mode —

supply reel table braking torque	direction A	150 ~ 250 g·cm (2.1 ~ 3.5 oz·inch)
	direction B	1,300 ~ 1,700 g·cm (18 ~ 24 oz·inch)

take-up reel table braking torque	direction C	350 ~ 450 g·cm (4.9 ~ 6.2 oz·inch)
	direction D	1,300 ~ 1,700 g·cm (18 ~ 24 oz·inch)

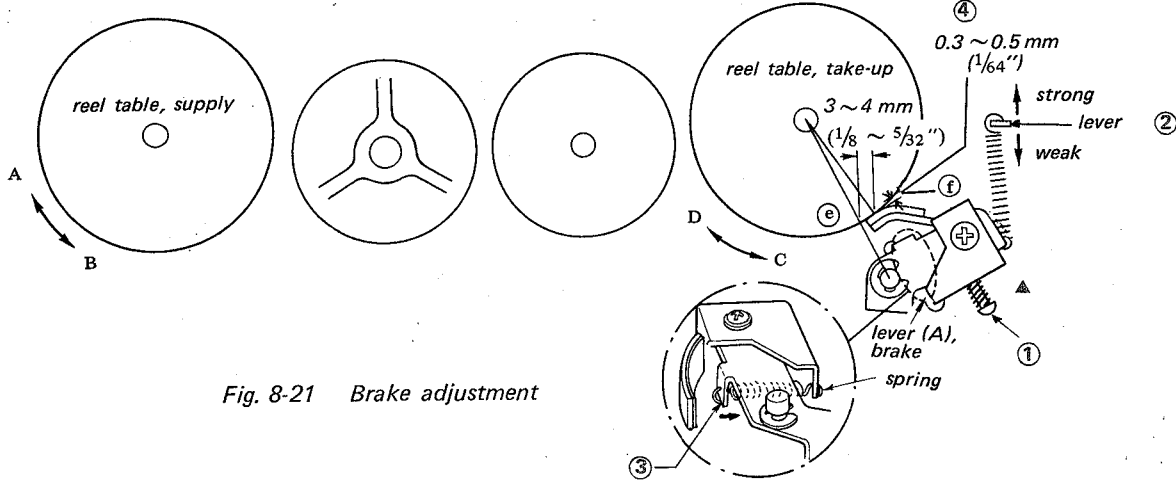

Fig. 8-21 Brake adjustment

8-15-1. Supply Brake Adjustment

Note: Make the supply brake torque adjustment, after having performed the tension regulator adjustment.

When the reading on the spring scale is greater than the values indicated, adjust by changing the position of the spring.

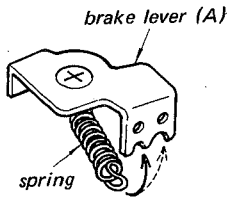

Fig. 8-22 Supply brake adjustment (1)

When the reading on the spring scale is less than the values indicated, adjust by bending the tab of the brake lever (B).

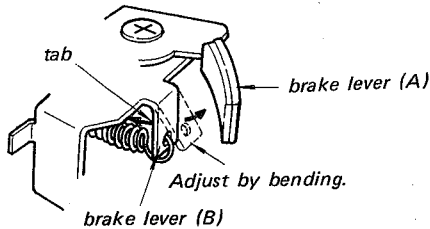

Fig. 8-23 Supply brake adjustment (2)

8-15-2. Take-up Brake Adjustment (Fig. 8-21)

① Brake Pressure Angle Adjustment

Adjust by turning the screw marked \blacktriangle so that the distance shown with \textcircled{e} is 3 ~ 4 mm ($1/8 \sim 5/32$ ”).

After the adjustment, apply lock paint to the screw.

② Take-up Brake Adjustment in the direction shown with C.

Adjust by bending the lever.

③ Take-up Brake Adjustment in the direction shown with D.

- When the reading on the spring scale is greater than the values indicated, bend the lever in the direction shown with the arrow.
- When the reading on the spring scale is less than the values indicated, cut off one turn of the spring end and hook the spring.

④ Make sure that the clearance between the take-up reel table and the brake is 0.3 ~ 0.5 mm ($1/64$ ”) in rewind mode.

8-15-3. Tape Slack Check

After the adjustments, thread the tape on the machine as shown in Fig. 8-24 and make sure not to slack the tape when changing to STOP mode from FF mode and slowly to REC mode from STOP mode.

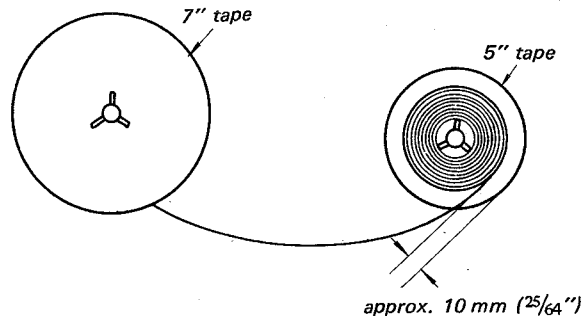

Fig. 8-24 Tape slack check

8-16. FF & REW Torque Adjustments

— in FF & REW modes —

Adjust the position of the leaf spring to obtain the specified values on the spring scale.
(Read the values when the driving idler is forced to stop the motion.)

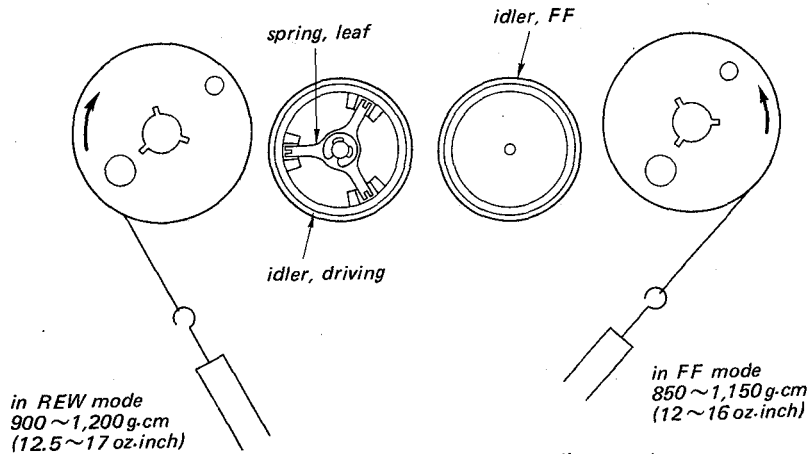
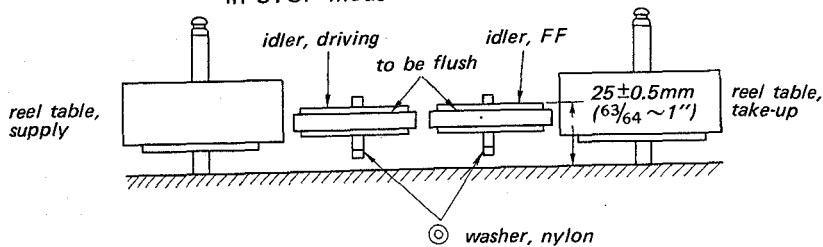

Fig. 8-25 FF & REW torque adjustments

8-17. FF & Driving Idler Height Adjustments

— in STOP mode —



nylon washer

Part No.	Thickness
3-425-197-01	0.13 mm
3-425-197-11	0.25 mm
3-425-197-21	0.50 mm

Adjust the height of the idler by adding or removing the nylon washer.

Fig. 8-26 FF & Driving idler height adjustments

8-18. Record Releasing Rod Adjustment

— in STOP mode —

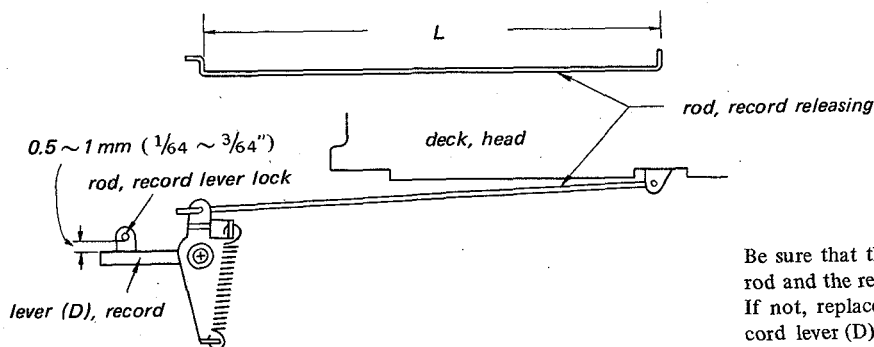

rod, record releasing

Part No.	L (length)
3-472-240-02	150mm
3-472-240-11	150.5mm
3-472-240-21	151mm

Be sure that the clearance between the record lever lock rod and the record lever (D) is 0.5 ~ 1 mm (1/64 ~ 3/64"). If not, replace the record releasing rod or bend the record lever (D).

Fig. 8-27 Record releasing rod adjustment

8-19. Tape Speed Adjustment

— in FWD mode —

(1) Play back the SONY speed check tape (SPC-47) at 19 cm/s (7 1/2 ips) tape speed in horizontal position.

(2) If the counter reading is out of 3,980 ~ 4,060 Hz replace with the motor pulley with identification mark shown below.
(As for Part No. of the motor pulley, refer to page 62.)

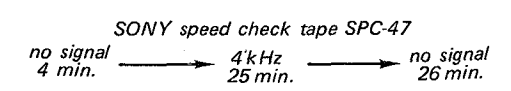
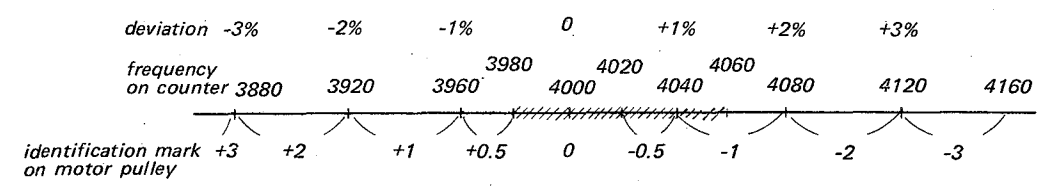

Specification:

	19cm/s (7 1/2 ips)	9.5cm/s (3 3/4 ips)
Deviation (%)	±1.5	±1.5
Variation Limit (%)	1	1

Fig. 8-28 Tape speed adjustment

MEMO

Series of horizontal dotted lines for taking notes.

9. ELECTRICAL ADJUSTMENT

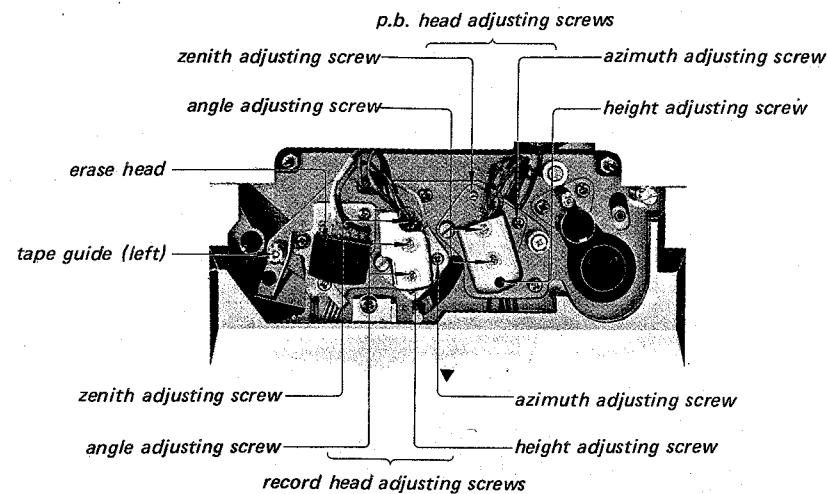

Fig. 9-1 Adjusting parts location (1)

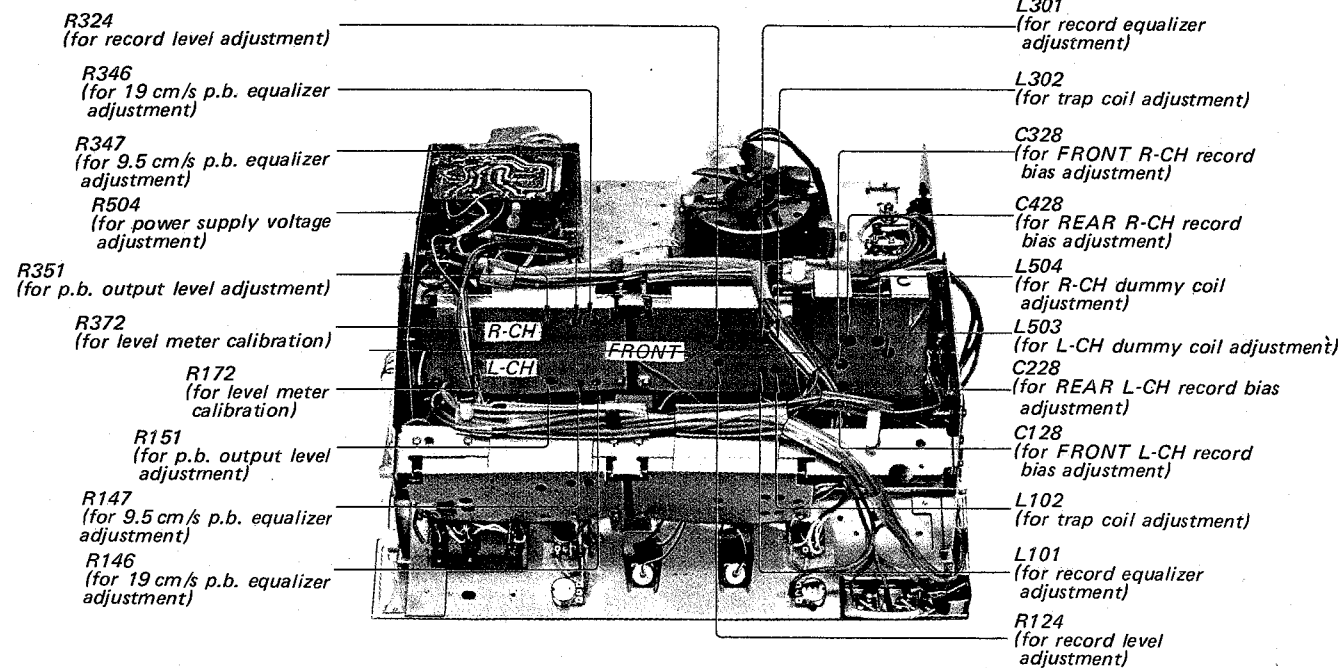

Fig. 9-2-1 Adjusting parts location (2)

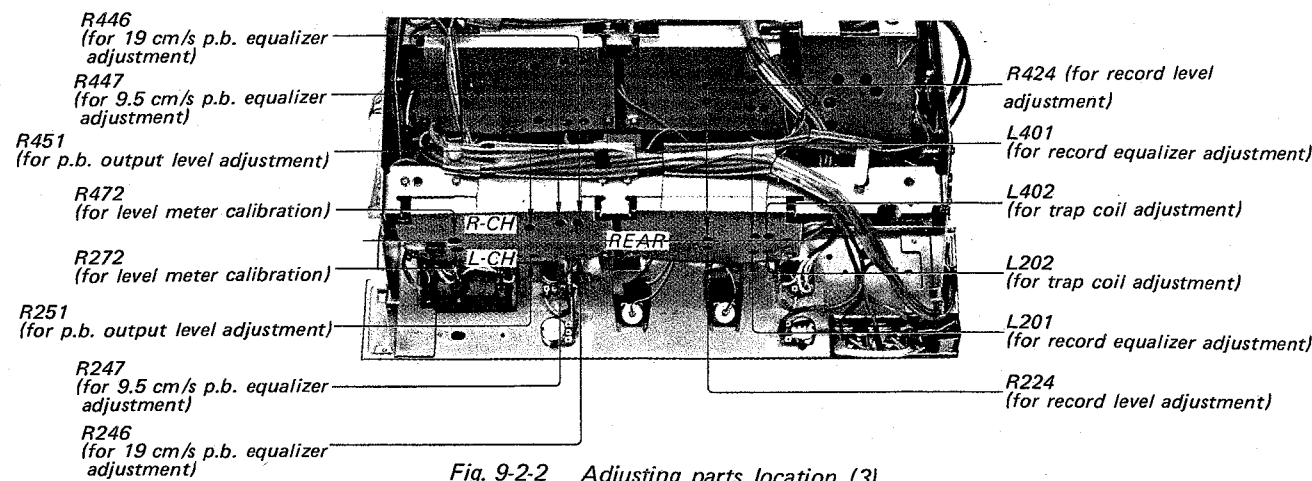

Fig. 9-2-2 Adjusting parts location (3)

Preparations:

- Before connecting the measuring equipments to the input or the output jack of the machine, take the impedance-matching correctly as shown below.

Input	Rated Input Level (Input Impedance)	Output	Rated Output Level (Load Impedance)
MIC	-60 dB (600Ω)	LINE OUT	0 dB (100 kΩ)
AUX	-10 dB (10 kΩ)	HEADPHONE	-28 dB (8 Ω)

Input Equipment Connection

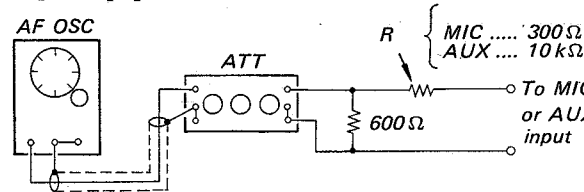

Output Equipment Connection

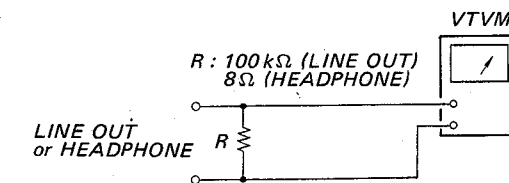

- During the adjustment, the RECORD VOLUME controls and the switches should be set in the following positions, unless otherwise specified.

MIC RECORD VOLUME: Set them to the position where the LINE OUT level is 0 dB (0.775 V) when delivering a 1 kHz signal of -60 dB (0.775 mV) into the MIC jack with the AUX RECORD VOLUME set to the minimum position and the MONITOR switch set to the SOURCE position.

AUX RECORD VOLUME: Set them to the position where the LINE OUT level is 0 dB (0.775 V) when delivering a 1 kHz signal of -10 dB (0.24 V) into the AUX IN jack with the MIC RECORD VOLUME set to the minimum position and the MONITOR switch set to the SOURCE position.

- TAPE SELECT switch: NORMAL.
- TAPE SPEED switch: 19 cm/s (7 1/2 ips)
- NOISE SUP-PRESS switch: OFF
- MONITOR switch: TAPE

- Before making the head adjustment, demagnetize and clean the record head and the p.b. head with swab or soft cloth dampened with denatured alcohol.
- A sufficiently-demagnetized tape should be used as a blank tape.
- Alignment tapes contain the following information:

Position	1st tone	2nd tone	3rd tone	4th tone	5th tone	6th tone	7th tone
J-19-K1	10kHz -10dB	400Hz 0dB	-	-	-	-	-
J-19-F1	10kHz -10dB	400Hz 0dB	400Hz -10dB	10kHz -10dB	7kHz -10dB	80Hz -10dB	40Hz -10dB

- The adjustment should be made in numerical order.
 1. Power Supply Voltage Adjustment
 2. Tape Path Adjustment
 3. Tape Curl Adjustment
 4. P.B. Head Azimuth & Phase Adjustment
 5. P.B. Output Level Adjustment
 6. P.B. Equalizer Adjustment
 7. Level Meter Calibration
 8. Trap Coil Adjustment
 9. Record Head Track Position Adjustment
 10. Record Head Azimuth Adjustment
 11. Record Bias Adjustment
 12. Record Level Adjustment
 13. Record Equalizer Adjustment
 14. Overall Frequency Response, S/N Ratio and Distortion Measurements
 15. Dummy Coil Adjustment
 16. Erase Ratio Measurement

9-1. Power Supply Voltage Adjustment

Adjustment Procedure:

- (1) Place the machine in STOP mode.
- (2) Be sure that the correct ac power supply voltage is supplied.
- (3) Connect a VTVM to the emitter of Q501.
- (4) Adjust R504 with an insulated screwdriver to obtain 25~26 V on the VTVM.

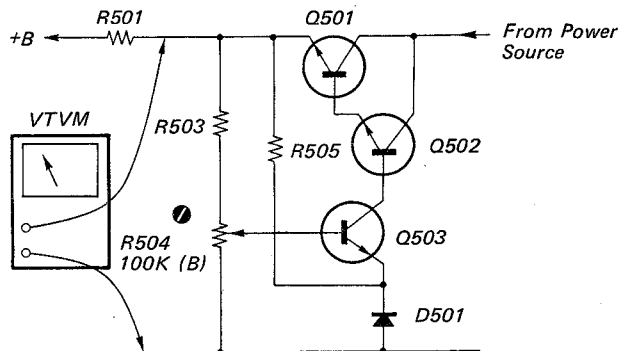

Fig. 9-3 Power supply voltage adjustment

9-2. Tape Path Adjustment

(A) Tape Guide (left) Adjustment

Adjusting Parts:

tape guide (left)..... See Fig. 9-1.

- (1) Thread a tape.
- (2) Align the upper edge of the tape just on the upper edge of the erase head core by turning the tape guide located on the left side of the erase head.
- (3) Turn the tape guide located on the left side of the erase head clockwise by approximately 35° from the position obtained in

the preceding procedures, so that the upper edge of the tape is approximately 0.05 mm lower than that of the erase head core.

(B) Tentative Record and P.B. Heads Adjustments

Adjusting Parts: (See Fig. 9-1)

- P.B. Head
 - ① azimuth adjusting screw
 - ② height adjusting screw
 - ③ zenith adjusting screw
- Record Head
 - ① azimuth adjusting screw
 - ② height adjusting screw
 - ③ zenith adjusting screw

Adjustment Procedures:

- (1) Thread a blank tape.
- (2) Set the machine in FWD mode at the 19 cm/s (7½ ips) tape speed.
- (3) Make the tape loose a little by pushing the tension regulator arm pin in the direction shown with the arrow in Fig. 9-5 and then adjust the p.b. head zenith and azimuth adjusting screws and the record head zenith and azimuth adjusting screws to obtain the reflection of light as shown in Fig. 9-5.
- (4) Set the machine in STOP mode.
- (5) Turn the p.b. head azimuth adjusting screw so that the upper edge of the p.b. head core is parallel with that of the tape.
- (6) Turn the p.b. head height adjusting screw to align the upper edge of the p.b. head core and that of the tape and memorize the number of turns of the screw.
- (7) Turn the p.b. head zenith adjusting screw by the same number of turns in the same direction of the p.b. head height adjusting screw.

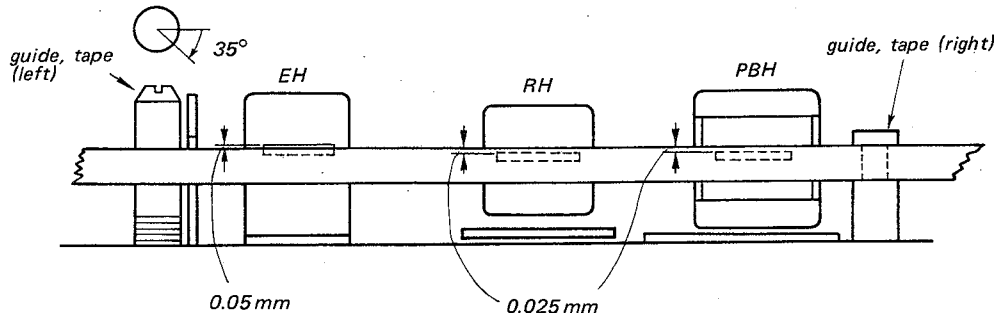

Fig. 9-4 Tape guide (left) adjustment

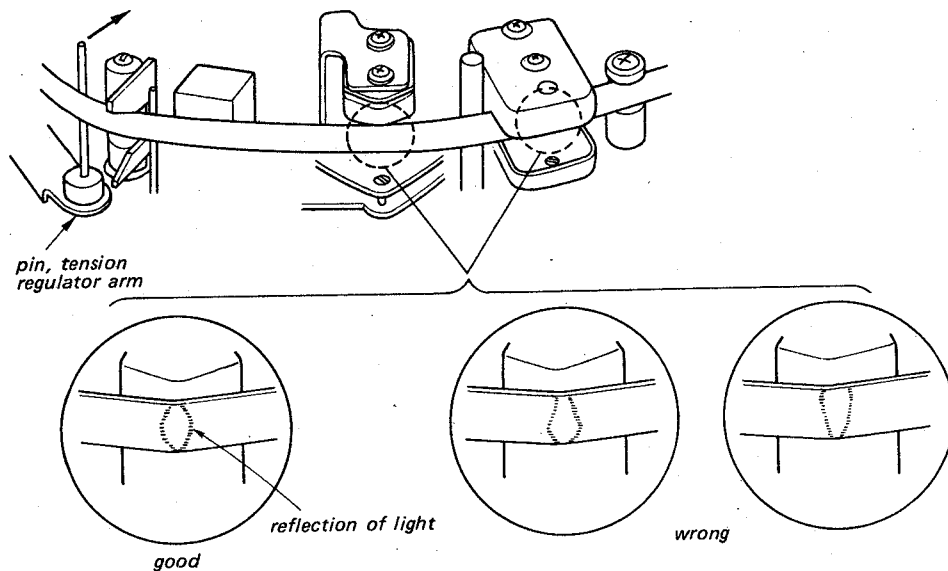

Fig. 9-5 Tentative record and p.b. heads adjustment

- (8) Repeat the above procedures (6) and (7) to align the upper edge of the p.b. head core and that of the tape.
- (9) Turn the p.b. head zenith and height adjusting screws counterclockwise by approximately 20° from the position obtained in the preceding procedure (8) so that the upper edge of the p.b. head core is 0.025mm lower than that of the tape.
- (10) Turn the record head azimuth adjusting screw so that the upper edge of the record head core is parallel with that of the tape.
- (11) Turn the record head height adjusting screw to align the upper edge of the record head core and that of the tape and memorize the number of turns of the screw.
- (12) Turn the record head zenith adjusting screw by the same number of turns in the same direction of the record head height adjusting screw.
- (13) Repeat the above procedures (11) and (12) to align the upper edge of the record head core and that of the tape.
- (14) Turn the record head zenith and height adjusting screws counterclockwise by approximately 20° from the position obtained in the preceding procedure (13) so that the upper edge of the record head core is 0.025 mm lower than that of the tape.
- (15) Set the machine in FWD mode at the 19 cm/s (7½ ips) tape speed.
- (16) Be sure to obtain the reflection of light as shown in Fig. 9-5 on the tape at the p.b. and record heads by pushing the tension regulator arm pin in the direction shown by the arrow in Fig. 9-5. If not, repeat the above procedures (3)~(14).

9-3. Tape Curl Adjustment

Adjustment Procedures:

- (1) Set the machine at 9.5 cm/s (3¾ ips) tape speed.
- (2) Be sure that the tape comes in contact with the two tape guides exactly as shown in Fig. 9-6.
 - If the tape is curled at the left tape guide, adjust by bending the tension regulator arm pin with fingers.
 - If the tape is curled at the right tape guide, loosen the two capstan bearing holding screws and adjust by adding or removing the mylar spacer.

Note: After adding or removing the mylar spacer, perform the p.b. head zenith adjustment.

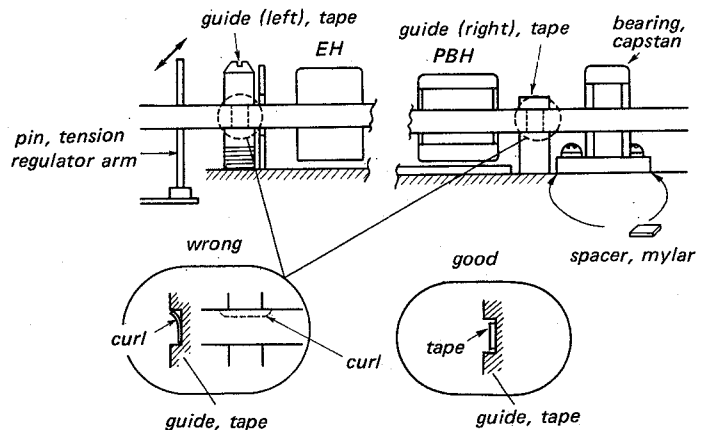

Fig. 9-6 Tape curl adjustment

9-4. P.B. Head Azimuth & Phase Adjustment

Adjustment Procedure:

- (1) Be sure that the tape path adjustment has been made.
- (2) Connect a VTVM to the LINE OUT jack.
- (3) Play back the 1st tone (10 kHz) of SONY alignment tape, J-19-F1 or J-19-K1.
- (4) Adjust the p.b. head azimuth adjusting screw with a non-magnetic screwdriver to obtain the maximum reading on the VTVM at four channels.
- (5) Memorize the angle of azimuth adjusting screw obtained the maximum VTVM reading at every channel.
- (6) If the maximum value of every channel can not be obtained at the same angle of the screw, take the mid position between the farthest two angles among four channels.
- (7) Recheck the value on the VTVM at every channel. At that time, if the difference between the maximum and the minimum readings is more than 1 dB on the VTVM, replace the p.b. head, and repeat the procedures from 9-2 to 9-4.
- (8) If the azimuth adjusting screw is turned more than 180 degrees, readjust the tape path.
- (9) Apply the lock paint to the azimuth adjusting screw.

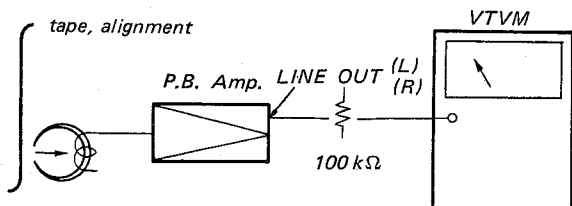

Fig. 9-7 P.B. head azimuth and phase adjustment setup

- (10) Disconnect the VTVM.
- (11) Connect an oscilloscope to the LINE OUT or the HEADPHONE jack.
- (12) Play back the 2nd tone (400 Hz) of SONY alignment tape, J-19-F1 or J-19-K1.
- (13) Make sure that the Lissajous figures on the oscilloscope between left and right channels and also front and rear channels indicate the same phase.
- (14) If the phase is not the same, readjust the steps from 2 to 9.

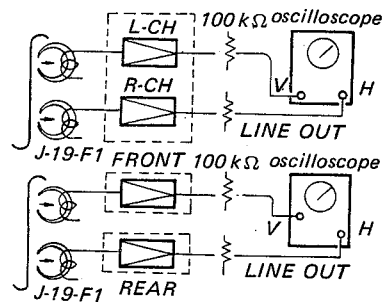

Fig. 9-8 P.B. head phase check

9-5. P.B. Output Level Adjustment

Adjustment Procedure:

- (1) Connect a VTVM to the LINE OUT jack.
- (2) Play back the 2nd tone (400 Hz) of SONY alignment tape, J-19-F1 or J-19-K1.
- (3) Set the MONITOR switch to the TAPE position.
- (4) Adjust R151, R251, R351 and R451 to obtain 0 dB (0.775V) on the VTVM.
- (5) Apply the lock paint to the semi-fixed resistors.

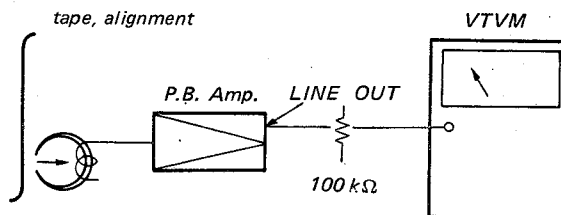

Fig. 9-9 P.B. output level adjustment

9-6. P.B. Equalizer Adjustment

Adjustment Procedure:

- (1) Connect a VTVM to the LINE OUT jack.
- (2) Set the MONITOR switch to the TAPE position.
- (3) Set the TAPE SPEED switch to the 19 cm/s (7½ ips) position.
- (4) Play back the 3rd tone (400 Hz) of SONY alignment tape J-19-F1.
- (5) Memorize the reading on the VTVM at four channels.
- (6) Play back the 4th tone (10 kHz) of SONY alignment tape J-19-F1.

- (7) Adjust R146, R246, R346 and R446 so that the VTVM indicates 0.5 dB lower than the value obtained in the preceding step 5 at every channel.
- (8) Play back the 5th, 6th and 7th tones of SONY alignment tape J-19-F1.
- (9) Check that the reading on the VTVM at every tone indicates the specified value as described below.
- (10) Change the TAPE SPEED switch to the 9.5 cm/s (3³/₄ ips) position.
- (11) Play back the 3rd tone of SONY alignment tape J-19-F1.
- (12) Memorize the reading on the VTVM at four channels.
- (13) Play back the 4th tone of SONY alignment tape J-19-F1.
- (14) Adjust R147, R247, R347 and R447 so that the VTVM reading is the same as the reading obtained in the preceding step 12 at every channel.
- (15) Play back the 5th tone of SONY alignment tape J-19-F1.
- (16) Check that the reading on the VTVM indicates the specified value as described below.

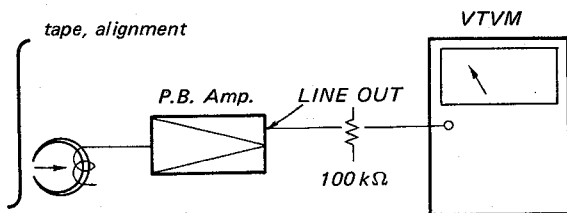

Fig. 9-10 P.B. equalizer adjustment setup

Deviation against 400Hz at 19 cm/s tape speed

tone tape	4th (10 kHz)	5th (7 kHz)	6th (80 Hz)	7th (40 Hz)
J-19-F1	-0.5 dB	-0.5±2 dB	+1.5±2 dB	+2.5±2 dB

Deviation against 200Hz at 9.5 cm/s tape speed

tone tape	4th (5 kHz)	5th (3.5 kHz)
J-19-F1	±1 dB	±2 dB

9-7. Level Meter Calibration

Adjustment Procedure:

- (1) Connect a VTVM to the LINE OUT jack.
- (2) Connect an AF Oscillator to the MIC jack.
- (3) Set the MONITOR switch to the SOURCE position.
- (4) Deliver a 1 kHz signal of -60 dB (0.77 mV) into the MIC jack from the AF Oscillator.
- (5) Adjust the MIC VOLUME control so that the output level of LINE OUT becomes 0 dB (0.775 V).
- (6) Adjust R172, R272, R372 and R472 to indicate the position illustrated below on the level meter.
- (7) Check the output level of LINE OUT when the TAPE SELECT switch is in the NORMAL position.
- (8) Set the TAPE SELECT switch to the SPECIAL position.
- (9) Make sure that the VTVM indicates 2~3 dB lower than the value obtained in the preceding step 7 at every channel.

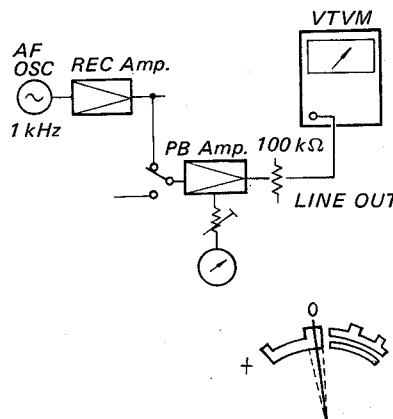

Fig. 9-11 Level meter calibration setup

9-8. Trap Coil Adjustment

Adjustment Procedure:

- (1) Connect a VTVM to the check point shown in Fig. 9-12.
- (2) Place the machine in 4-channel stereo record mode.
- (3) Set the MIC and AUX VOLUME control counterclockwise to the full.
- (4) Adjust L102, L202, L302 and L402 to obtain the minimum reading on the VTVM.

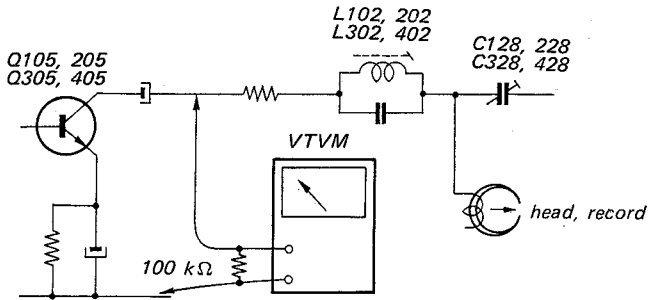

Fig. 9-12 Trap coil adjustment setup

9-9. Record Head Track Position Adjustment

Adjustment Procedure:

- (1) Make sure that the tape path adjustment has been made.
- (2) Set the MONITOR switch to TAPE position.
- (3) Connect an AF Oscillator to the MIC jack of FRONT R-channel.
- (4) Connect a VTVM to the LINE OUT jack.
- (5) Set the MIC VOLUME control of FRONT R-channel to the specified position in the preparation.
- (6) Deliver a 1 kHz signal of -60 dB (0.775 mV) into the MIC jack.
- (7) Thread a blank tape and place the machine in the record mode.
- (8) Adjust the azimuth, height and zenith adjusting screws of record head for the maximum reading on the VTVM.
- (9) After the adjustment, check the tape path again.

- (7) Adjust the record head azimuth adjusting screw for the maximum reading on the VTVM at every channel.
- (8) Memorize the angle of azimuth adjusting screw where the maximum VTVM reading at every channel is obtained.
- (9) If the maximum value of every channel can not be obtained at the same angle of the screw, take the mid between the farthest two angles among four channels.
- (10) Recheck the value on the VTVM at every channel. At that time, if the difference between the maximum and the minimum readings is more than 1 dB on the VTVM, replace the record head, and repeat the procedures 9-2, 9-9 and 9-10.
- (11) If the azimuth adjusting screw is turned more than 180 degrees, readjust record head track position adjustment.
- (12) Apply the lock paint to the azimuth adjusting screw.

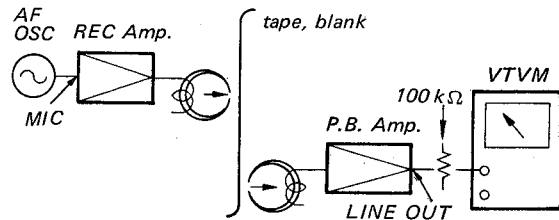

Fig. 9-14 Record head azimuth adjustment setup

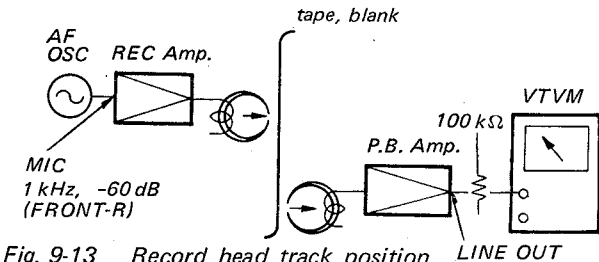

Fig. 9-13 Record head track position adjustment setup

9-10. Record Head Azimuth Adjustment

Adjustment Procedure:

- (1) Set the MONITOR switch to TAPE position.
- (2) Connect an AF Oscillator to the MIC jack.
- (3) Connect a VTVM to the LINE OUT jack.
- (4) Set the MIC VOLUME control to the specified position in the preparation (2).
- (5) Deliver a 1 kHz signal of -90 dB (24.5 μV) into the MIC jack from the AF Oscillator.
- (6) Thread a blank tape and place the machine in the record mode.

9-11. Record Bias Adjustment

Adjustment Procedure:

- (1) Set the MONITOR switch to the TAPE position.
- (2) Connect an AF Oscillator to the MIC jack.
- (3) Connect a VTVM to the LINE OUT jack.
- (4) Set the MIC VOLUME control to the specified position in the preparation (2).
- (5) Deliver a 1 kHz signal of -60 dB (0.775 mV) into the MIC jack from the AF Oscillator.
- (6) Thread a blank tape and place the machine in the record mode.
- (7) Turn the trimmer capacitors C128, C228, C328 and C428 fully clockwise and turn it several turns counterclockwise.
- (8) Turn the trimmer capacitors clockwise slowly until the VTVM reads the maximum value.
- (9) Change the 1 kHz signal level from -60 dB (0.775 mV) to -90 dB (24.5 μV).
- (10) Turn the trimmer capacitors finely to obtain the maximum value on the VTVM.
- (11) Change the signal from 1 kHz to 10 kHz.

- (12) Finely turn the trimmer capacitors clockwise so that the line output level at 10 kHz is 0 ± 5 dB against the output at 1 kHz.

Note: The output level at 1 kHz should not drop more than 1 dB below the peak level.

- (13) Apply the lock paint to the trimmer capacitors.

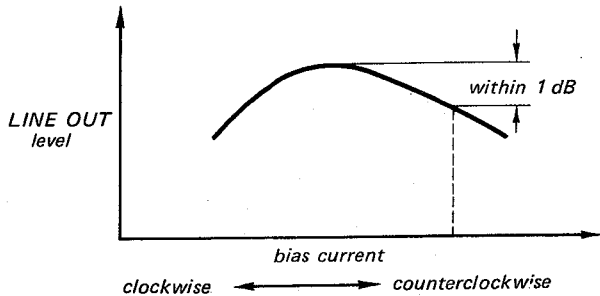

Fig. 9-15 Record bias characteristics

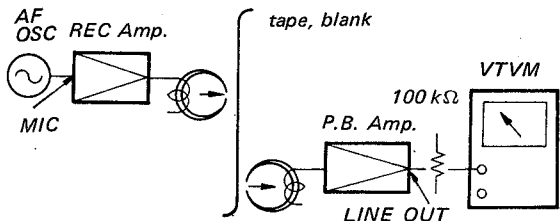

Fig. 9-16 Record bias adjustment setup

9-12. Record Level Adjustment

Adjustment Procedure:

- (1) Set the MONITOR switch to the TAPE position.
- (2) Connect the AF Oscillator to the MIC jack.
- (3) Connect a VTVM to the LINE OUT jack.
- (4) Set the MIC VOLUME control to the specified position in the preparation (2).
- (5) Deliver a 1 kHz signal of -60 dB (0.775 mV) into the MIC jack from the AF Oscillator.
- (6) Thread a blank tape and place the machine in the 4-channel stereo record mode.
- (7) Adjust R124, R224, R324 and R424 to obtain 0 dB (0.775 V) on the VTVM.
- (8) Make sure that the difference between the level in the 4-channel record mode and the level in the 2-channel record mode is within 1 dB.
- (9) Change the TAPE SPEED switch to the 9.5 cm/s position.
- (10) Place the machine in the 4-channel stereo record mode.
- (11) Make sure that the difference of level between channels is within 2 dB.

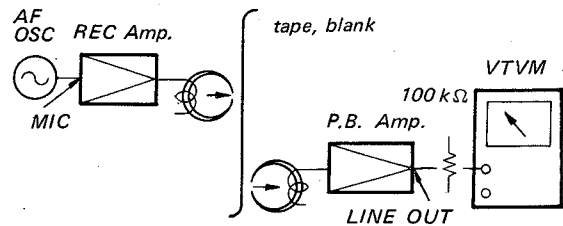

Fig. 9-17 Record level adjustment setup

9-13. Record Equalizer Adjustment

Adjustment Procedure:

- (1) Connect an AF Oscillator to the MIC jack and a VTVM to the LINE OUT jack.
- (2) Set the MONITOR switch to the TAPE position and the MIC VOLUME control to the specified position in the preparation (2).
- (3) Deliver a 1 kHz signal of -90 dB (24.5μ V) into the MIC jack from the AF Oscillator.
- (4) Record the signal on the blank tape.
- (5) Change the signal from 1 kHz to 18 kHz.
- (6) Adjust the equalizer coils L101, L201, L301 and L401 so that the VTVM indicates the same output level between the two signals.

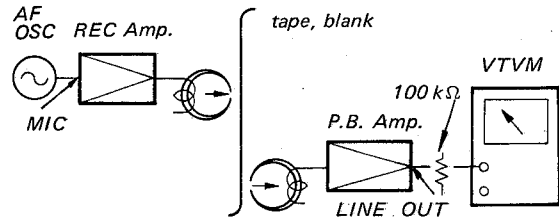

Fig. 9-18 Record equalizer adjustment setup

9-14. Overall Frequency Response, S/N Ratio and Distortion Measurements

Adjustment Procedure:

- (1) Connect an AF Oscillator to the MIC jack and a VTVM to the LINE OUT jack.
- (2) Set the MONITOR switch to the TAPE position and the MIC VOLUME control to the specified position in the preparation (2).
- (3) Deliver a 1 kHz signal of -90 dB (24.5μ V) into the MIC jack from the AF Oscillator.
- (4) Record the signal on a blank tape and memorize the VTVM reading.
- (5) Deliver 50 Hz, 100 Hz, 5 kHz, 7 kHz, 12.5 kHz and 18 kHz signals in turn and record them on the blank tape and memorize the VTVM readings respectively.
- (6) Be sure that each deviation in level against 1 kHz signal is within the values shown in the following table at the tape speeds of 19 cm/s and 9.5 cm/s. If not, perform the record equalizer and the record bias adjustments.

Deviation against the 1 kHz signal

frequency	50 Hz	100 Hz	5 kHz	7 kHz	12.5 kHz	18 kHz
tape speed						
19 cm/s (7 1/2 ips)	+2 -4 dB	± 3 dB	± 3 dB	± 3 dB	± 3 dB	+3 -6 dB
9.5 cm/s (3 3/4 ips)	+3 -8 dB	± 3 dB	± 3 dB	± 3 dB	+ 3 -12 dB	-

- (7) Deliver a 1 kHz signal of -60 dB (0.775 mV) into the MIC jack from the AF Oscillator.
- (8) Record the signal on a blank tape.
- (9) Rewind the recorded tape, terminate the four MIC jack with a 600Ω resistor and erase a part of the recorded tape (record mode with no signal input).
- (10) Be sure that the output level difference between the two parts is more than 46 dB on the VTVM.
- (11) Disconnect the VTVM.
- (12) Connect a distortion meter to the LINE OUT jack.
- (13) Record the 1 kHz signal of -60 dB (0.775 mV) and play back the signal.
- (14) Be sure that the reading on the distortion meter is less than 1.5%.

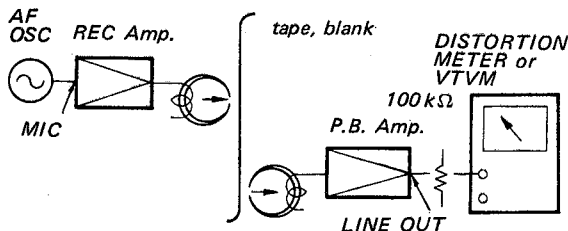

Fig. 9-19 Overall frequency response, S/N ratio and distortion measurements setup

9-15. Dummy Coil Adjustment

Adjustment Procedure:

- (1) Connect an AF Oscillator to the MIC jack and a VTVM to the LINE OUT jack.
- (2) Set the MONITOR switch to the TAPE position and the MIC VOLUME control to the specified position in the preparation (2).
- (3) Deliver a 18 kHz signal of -80 dB (77.5 μV) into the MIC jack from the AF Oscillator.
- (4) Thread a blank tape and place the machine in 4-channel stereo record mode.
- (5) Memorize the VTVM reading.
- (6) Set the FRONT channel only in the record mode.
- (7) Adjust L504 with a non-magnetic screwdriver so that the VTVM reading is the same as the reading memorized in preceding step 5.

- (8) Reset the REAR channel only in the record mode.
- (9) Adjust L503 with a non-magnetic screwdriver so that the VTVM reading is the same as the reading memorized in preceding step 5.

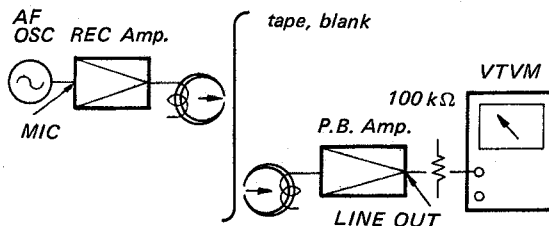

Fig. 9-20 Dummy coil adjustment setup

9-16. Erase Ratio Measurement

Adjustment Procedure:

- (1) Connect an AF Oscillator to the MIC jack.
 - (2) Connect a VTVM to the LINE OUT jack through a band pass filter (BPF).
 - (3) Set the MONITOR switch to the TAPE position and the MIC VOLUME control to the specified position in the preparation (2).
 - (4) Deliver a 333 Hz signal of -50 dB (2.45 mV) into the MIC jack.
 - (5) Thread a blank tape and place the machine in the 2-channel stereo record mode (FRONT).
 - (6) Rewind the half parts of tape, terminate the four MIC jack with a 600Ω resistor and continue the recording (record mode with no signal input).
 - (7) Play back the recorded part and the erased part of the tape.
 - (8) Memorize the VTVM reading on the recorded part and the erased part of the tape.
 - (9) Be sure that the output level difference between the two parts is more than 65 dB on the VTVM.
- Note:** In this measurement, the level variation should be within 5 dB. If not, perform the tape path adjustment.
- (10) Perform the above steps for other 2-channels (REAR).

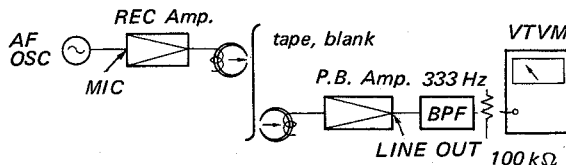
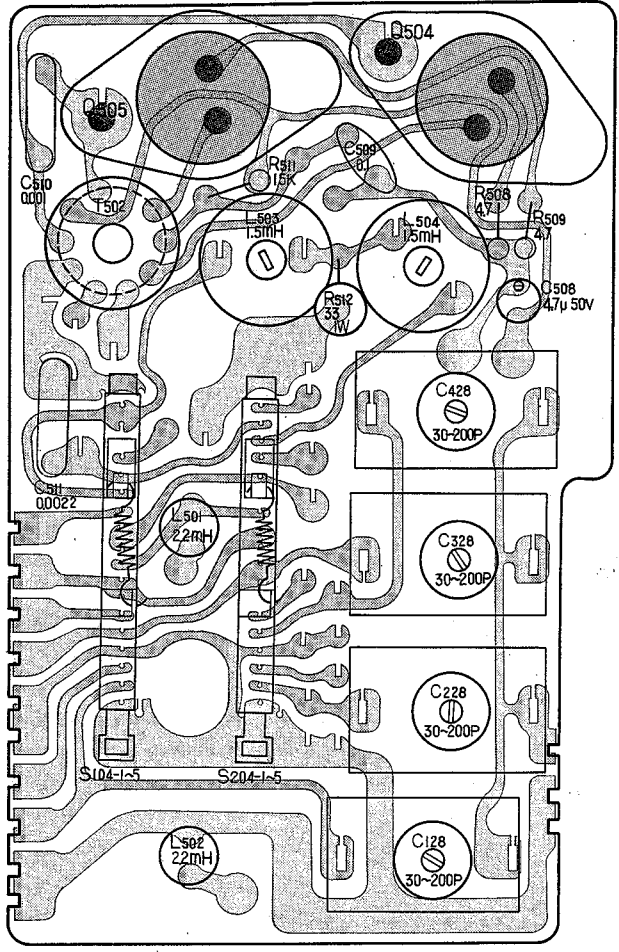

Fig. 9-21 Erase ratio measurement setup

10. MOUNTING DIAGRAM

10-1. Bias OSC Circuit Board

— Component Side —



10-1. Bias OSC Circuit Board

— Conductor Side —

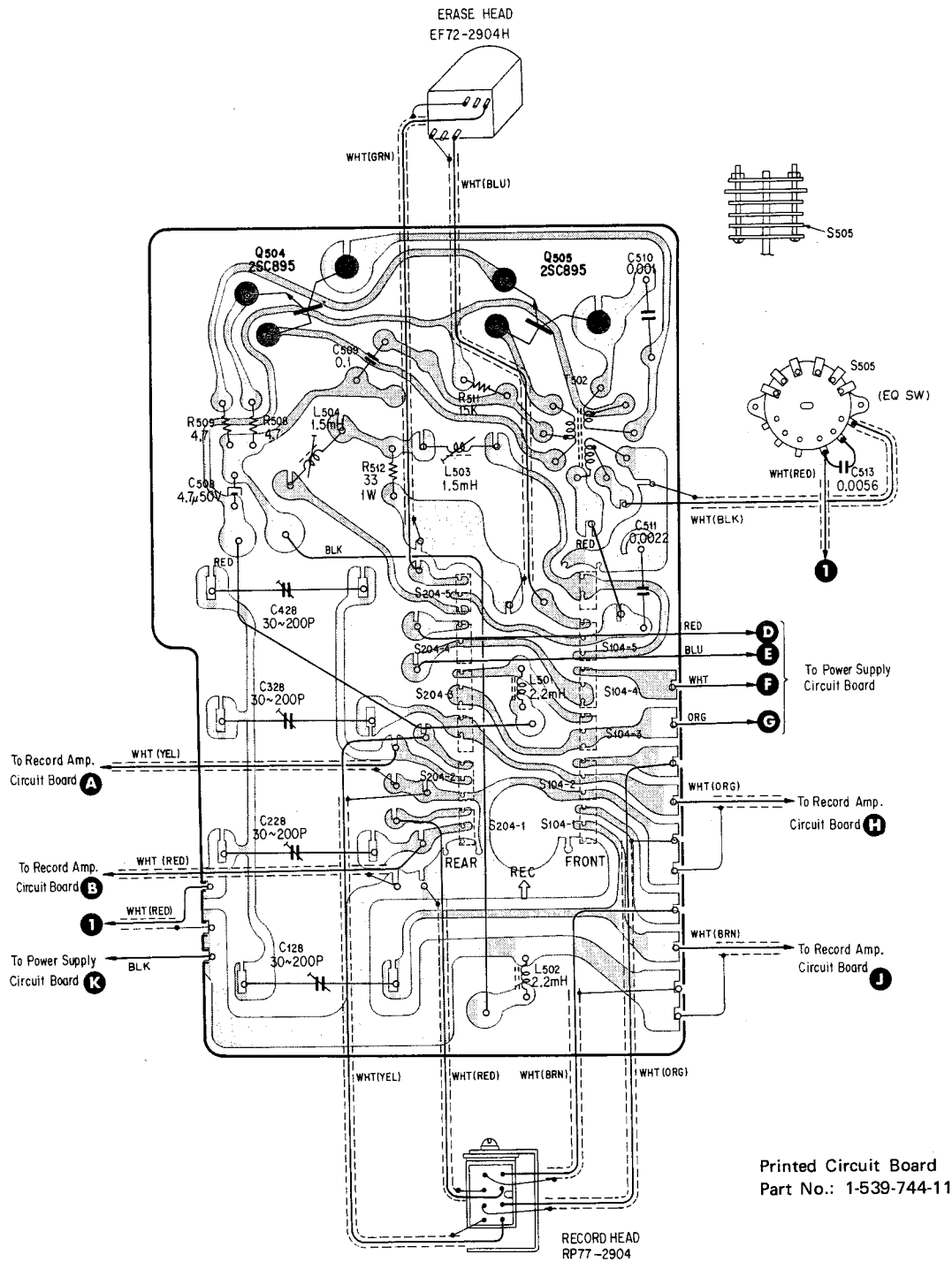

Printed Circuit Board
Part No.: 1-539-744-11

2SC895

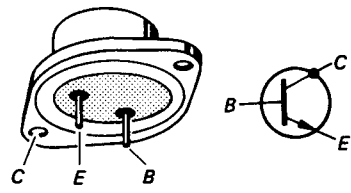

Adjusting Parts:

- C128, 228, 328, 428
(for Record Bias Adjustment)
- L503, 504
(for Dummy Coil Adjustment)

10-2. Power Supply Circuit Board
 — Component Side —

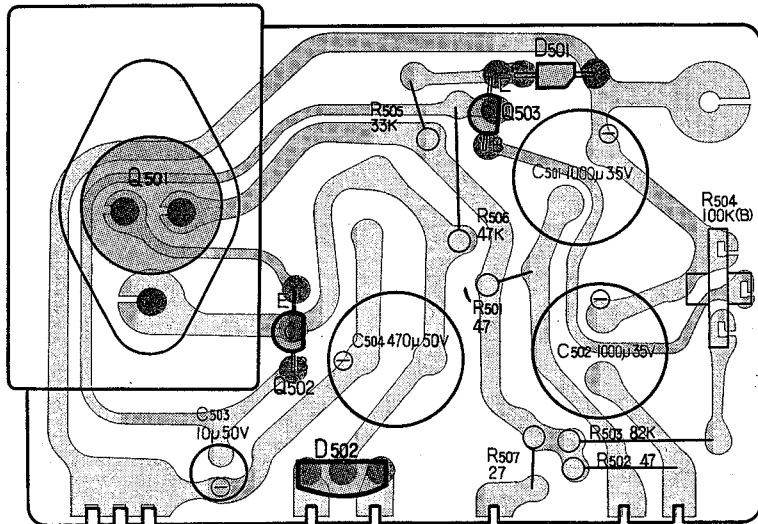

2SD28

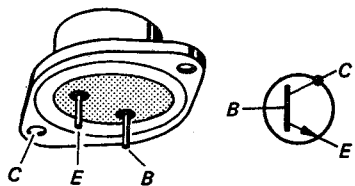

2SC870

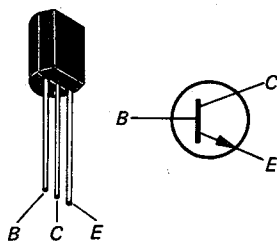

1T243M

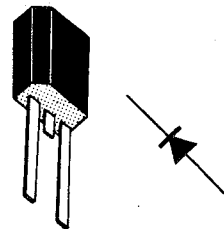

10-2. Power Supply Circuit Board
 - Conductor Side -

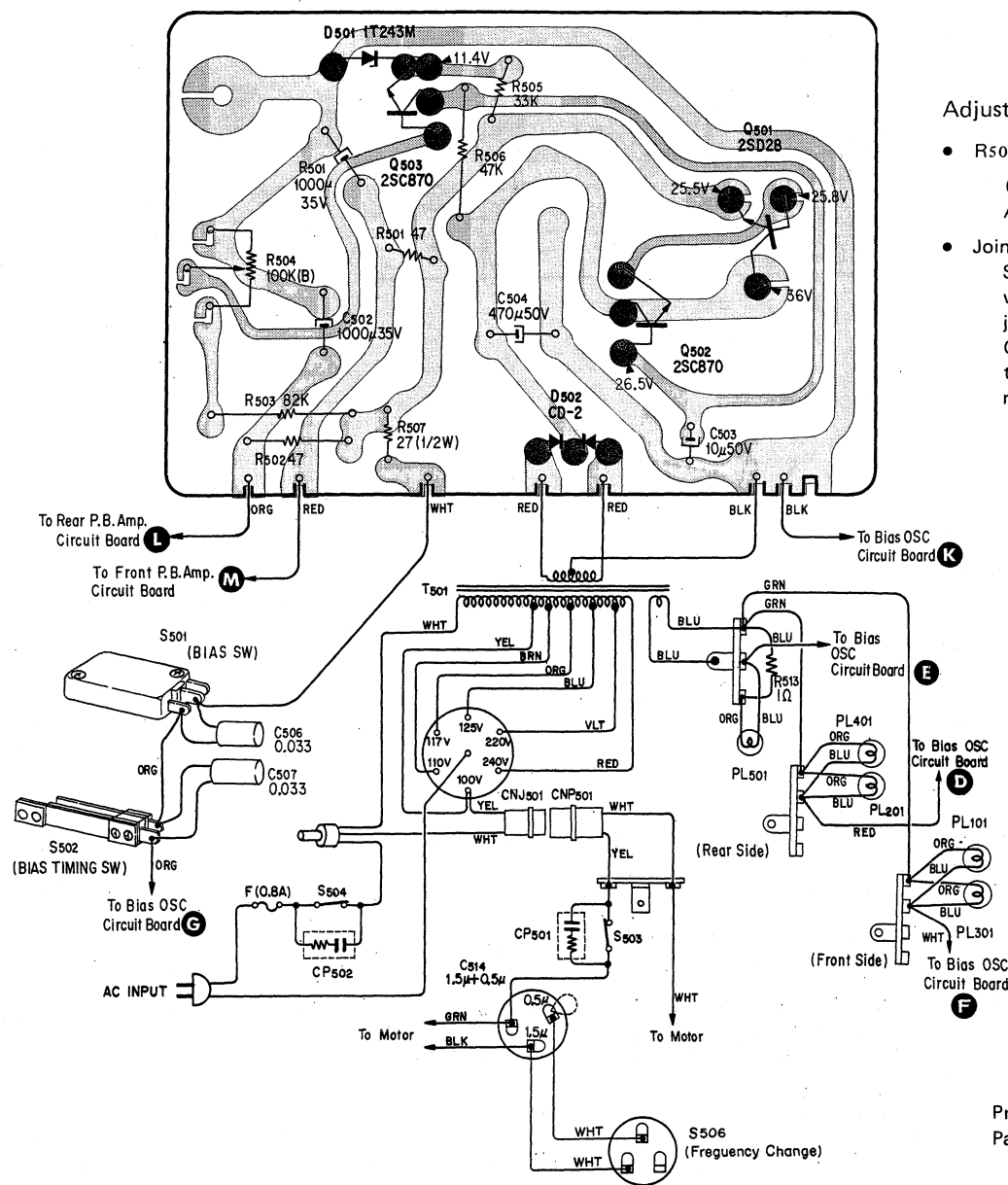

Adjusting Parts:

- R504
 (for Power Supply Voltage Adjustment)
- Joint Terminal
 S/N ratio will change by reversing the connection of the joint terminal CNP501 for CNJ501. Therefore connect them to obtain better S/N ratio.

Printed Circuit Board
 Part No.: 1-539-745-11

11. SCHEMATIC DIAGRAM
 11-1. Bias OSC & Power Supply Section

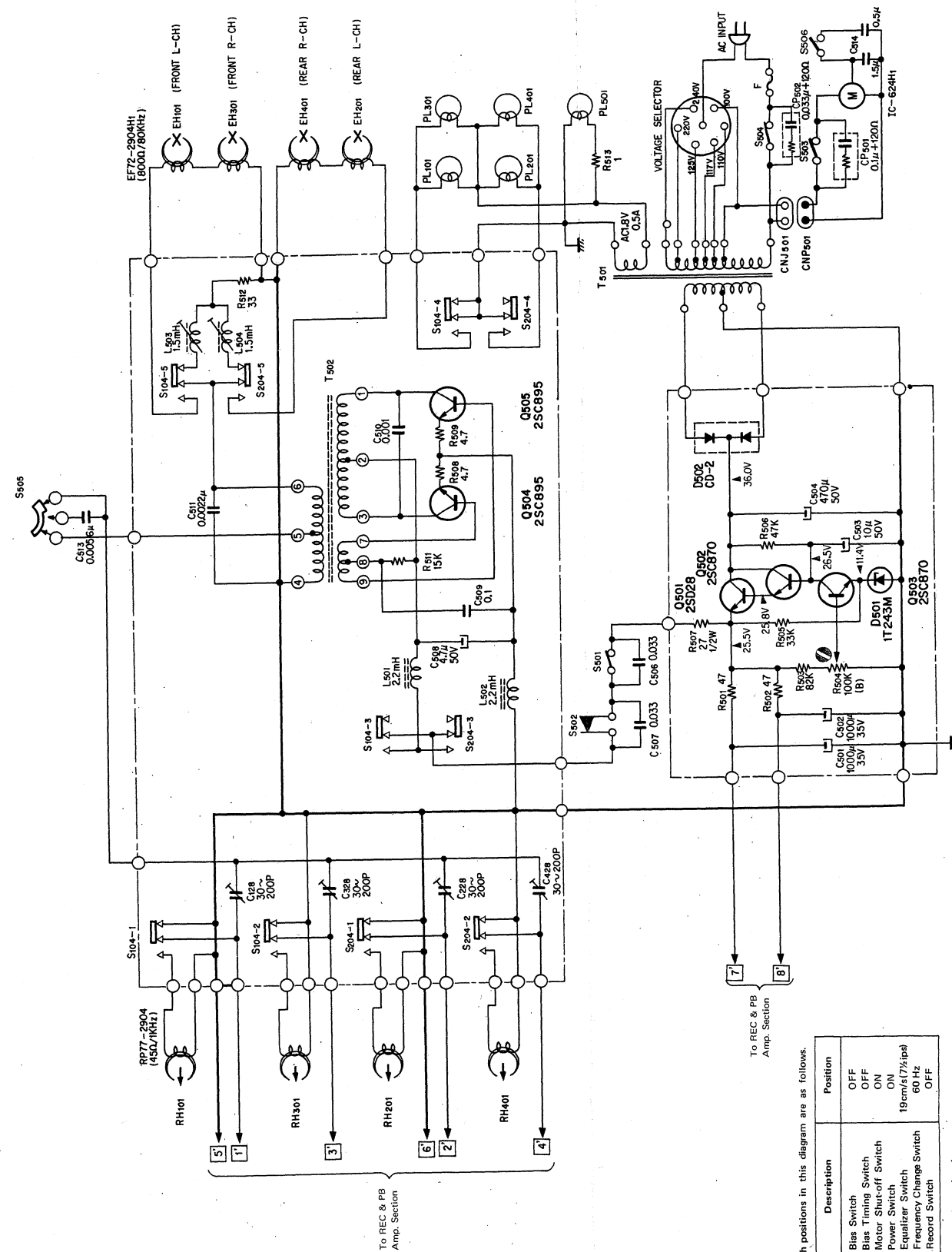

Notes:
 (1) The switch positions in this diagram are as follows.

Switch No.	Description	Position
S501	Bias Switch	OFF
S502	Bias Timing Switch	OFF
S503	Motor Shut-off Switch	ON
S504	Power Switch	ON
S505	Equalizer Switch	19cm (17 1/2 ips)
S506	Frequency Change Switch	OFF
S507, 508	Record Switch	OFF

(2) --- : grounded to chassis.
 (3) --- : indicates the semi-fixed resistor.
 (4) The letter (B) which is suffixed to the rating value of the resistor indicates its characteristic.
 (5) Voltage values are measured by using a voltmeter (20kΩ/V) in playback mode with no signal input.

11-2. REC & P.B. Amp. Section

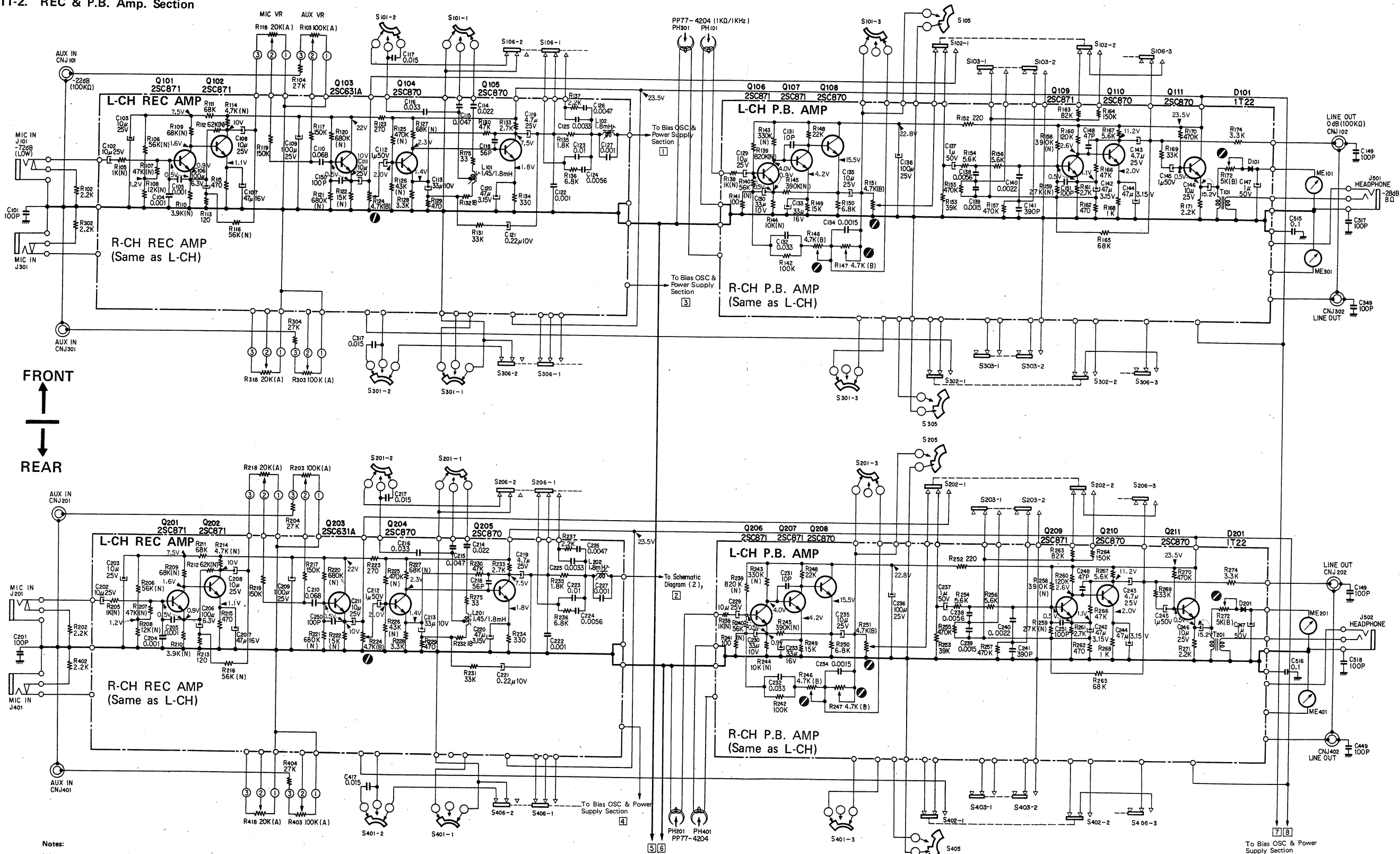

Notes:

(1) The switch positions in this diagram are as follows.

Switch No.	Description	Position
S101, 201, 301, 401	Equalizer Switch	19cm/s(7 1/2 ips)
S102, 202, 302, 402	Monitor Switch	TAPE
S103, 203, 303, 403	Noise Suppress Switch	OFF
S105, 205, 305, 405	Muting Switch	OFF
S106, 206, 306, 406	Tape Selector Switch	NORMAL

- (2) : grounded to chassis.
- (3) : indicates the semi-fixed resistor.
- (4) The letters (A) and (B) which are affixed to the rating value of the resistor indicate its characteristic.
- (5) The resistor whose rating value is suffixed with the letter (N) is a low-noise resistor.
- (6) Voltage values are measured by using a voltmeter (20 kΩ/V) in playback mode with no signal input.

10. MOUNTING DIAGRAM

10-3. REC Amp. Circuit Board – FRONT –

– Conductor Side –

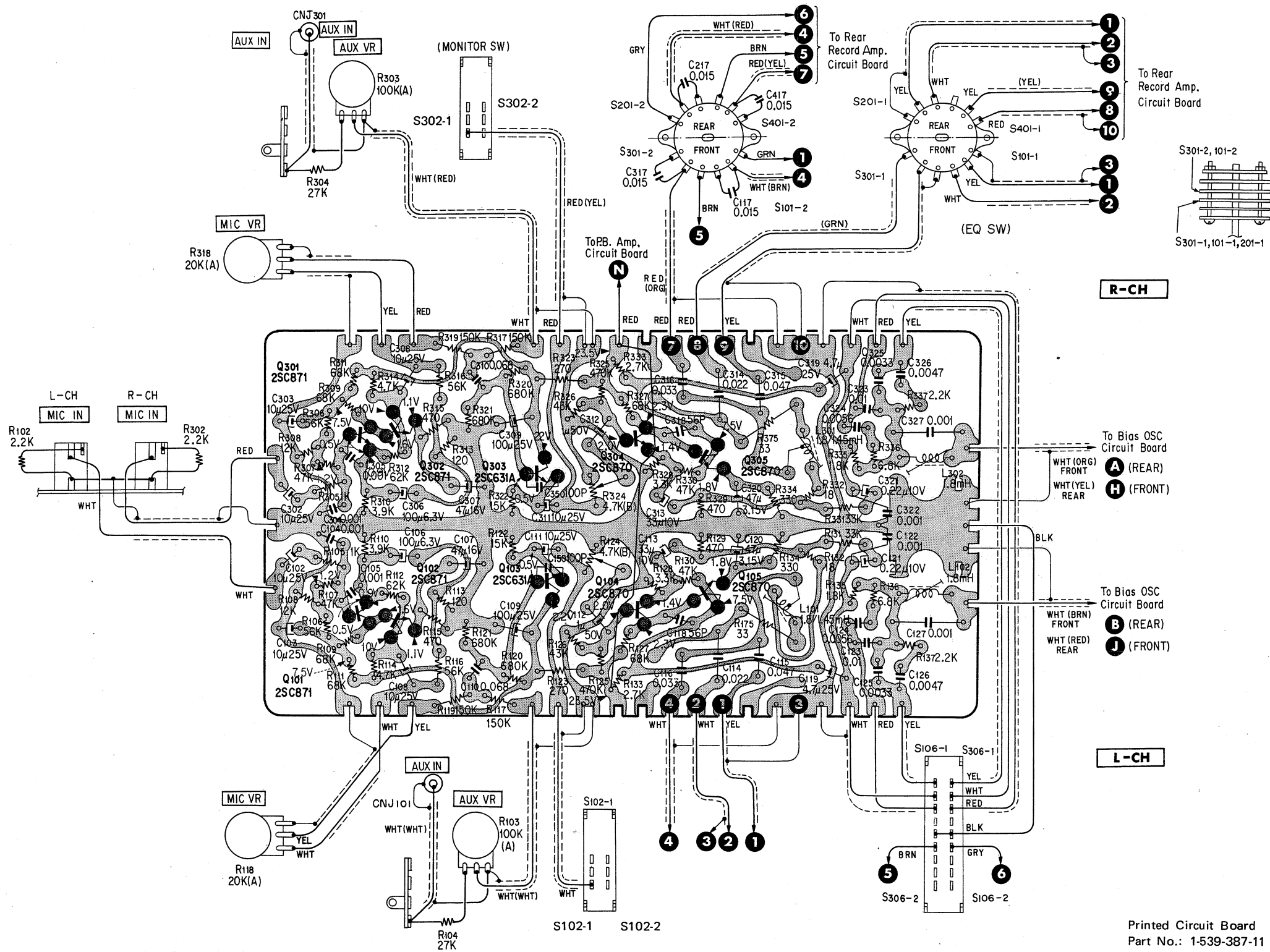

Adjusting Parts:

- R124, 224, 324, 424
(for Record Level Adjustment)
- L101, 201, 301, 401
(for Record Equalizer Adjustment)
- L102, 202, 302, 402
(for Trap Coil Adjustment)

Note: REAR Amp. Circuit Board is the same as FRONT one.

Printed Circuit Board
Part No.: 1-539-387-11

10-3. REC Amp. Circuit Board

- Component Side -

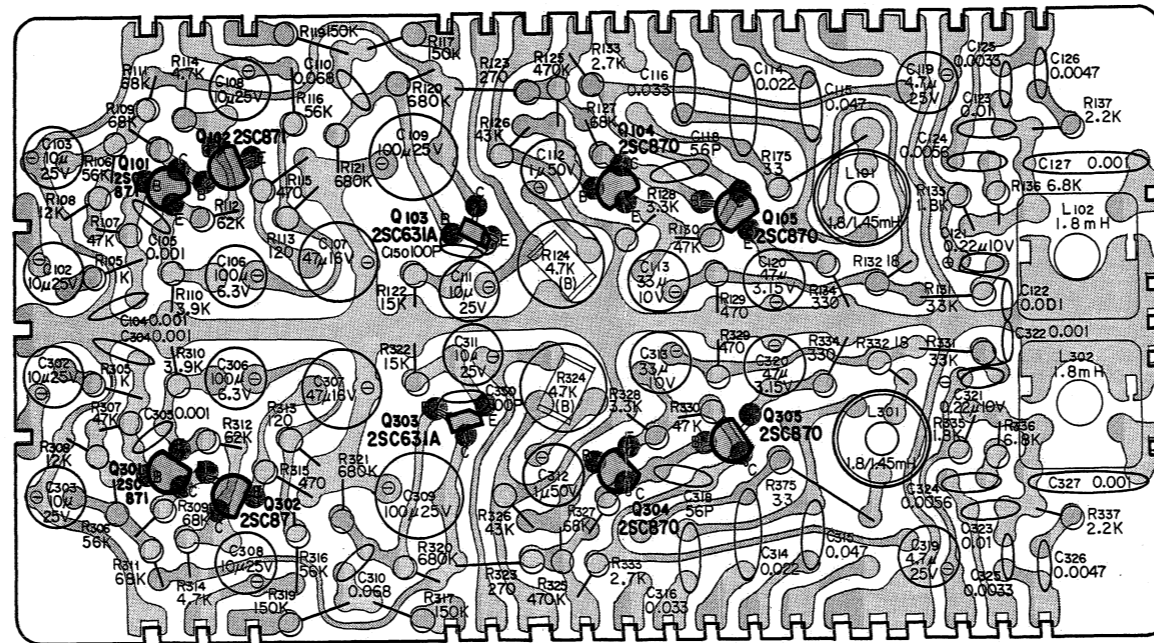

2SC870, 2SC871

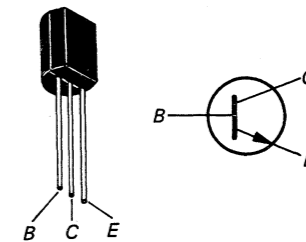

2SC631A

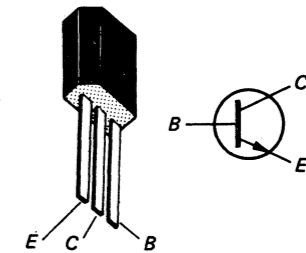

Note: REAR Amp. Circuit Board is the same as FRONT one.

10-4. P.B. Amp. Circuit Board - FRONT -
- Conductor Side -

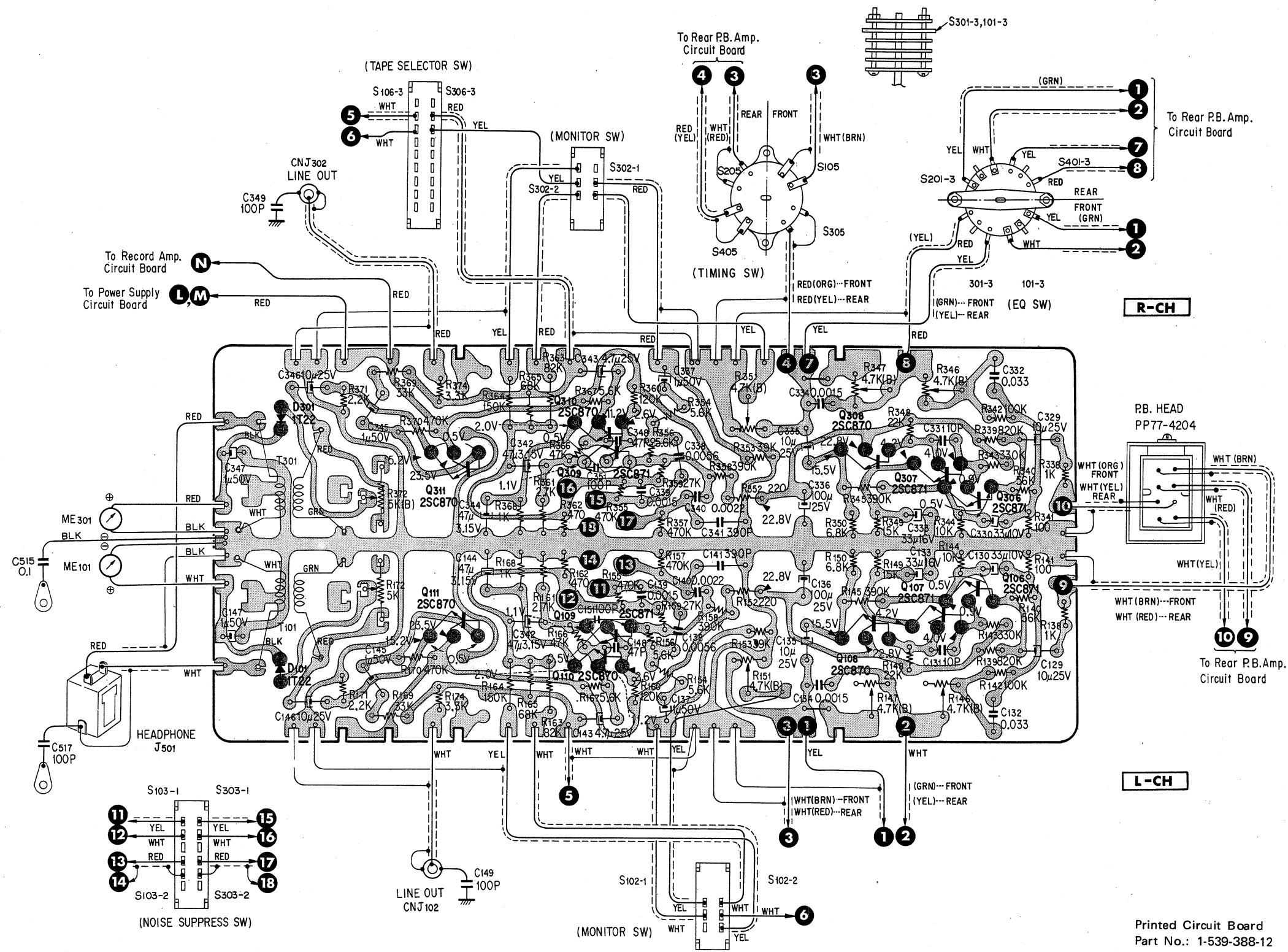

- Adjusting Parts:
- R146, 246, 346, 446
(for 19 cm/s P.B. Equalizer Adjustment)
 - R147, 247, 347, 447
(for 9.5 cm/s P.B. Equalizer Adjustment)
 - R151, 251, 351, 451
(for P.B. Output Level Adjustment)
 - R172, 272, 372, 472
(for Level Meter Calibration)
- Note: REAR Amp. Circuit Board is the same as FRONT one.

Printed Circuit Board
Part No.: 1-539-388-12

10-4. P.B. Amp. Circuit Board
 - Component Side -

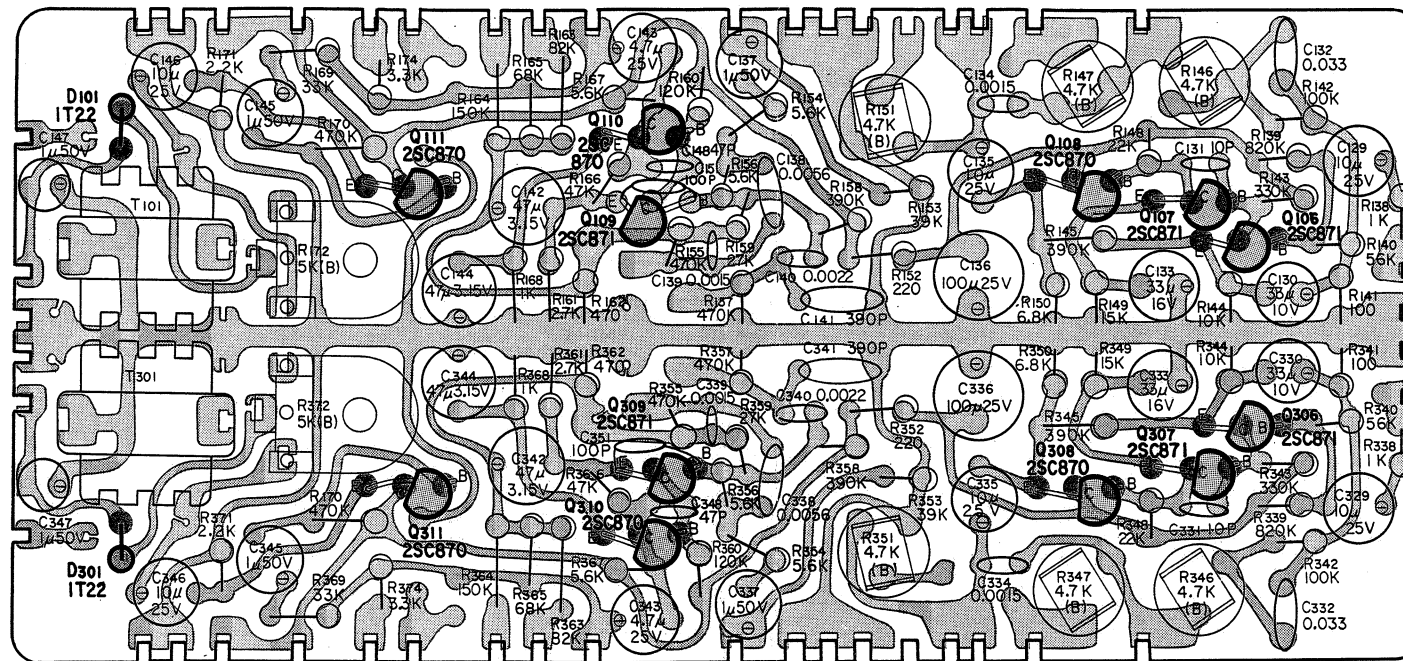

Note: REAR Amp. Circuit Board is the same as FRONT one.

2SC870, 2SC871

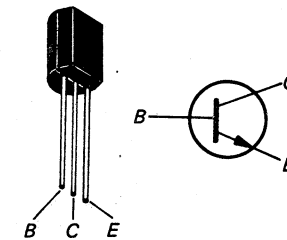

1T22

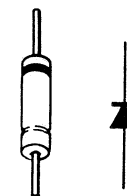

12. LEVEL DIAGRAM

12-1. Record

0dB = 0.775V, f = 1kHz

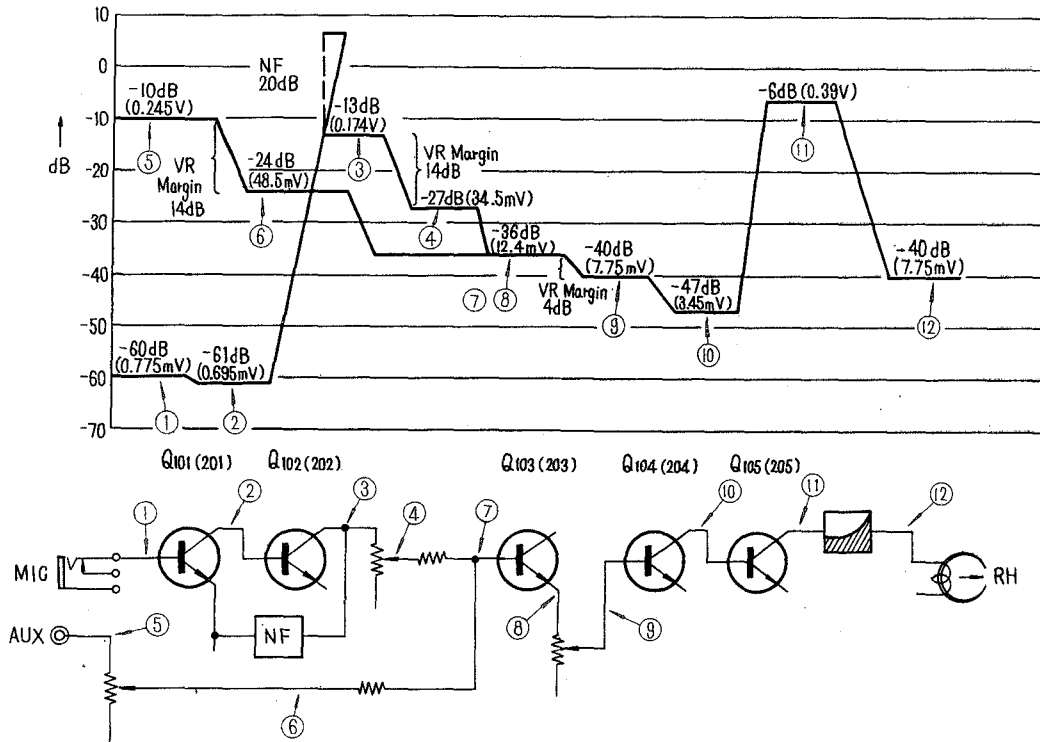

12-2. Playback

0dB = 0.775V, f = 1kHz

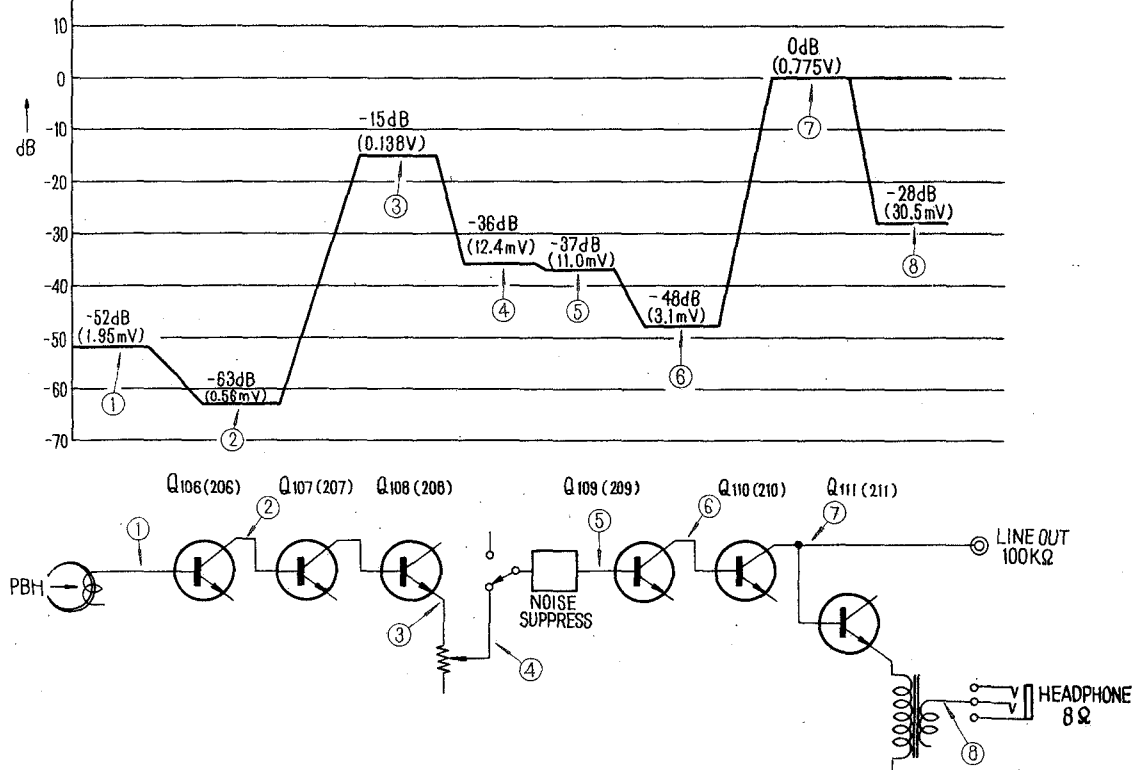

13. ELECTRICAL PARTS LIST

Ref. No. Part No. Description

MOUNTED CIRCUIT BOARDS

X-34840-51-1 record amp.
 X-34840-52-1 power supply
 X-34840-53-1 playback amp.
 X-34840-54-1 bias osc.

PRINTED CIRCUIT BOARDS

1-539-387-11 record amp.
 1-539-388-12 playback amp.
 1-539-744-11 bias osc.
 1-539-745-11 power supply

SEMICONDUCTORS

Q101, 201)	transistor	2SC871
Q301, 401			
Q102, 202)	transistor	2SC871
Q302, 402			
Q103, 203)	transistor	2SC631A
Q303, 403			
Q104, 204)	transistor	2SC870
Q304, 404			
Q105, 205)	transistor	2SC870
Q305, 405			
Q106, 206)	transistor	2SC871
Q306, 406			
Q107, 207)	transistor	2SC871
Q307, 407			
Q108, 208)	transistor	2SC870
Q308, 408			
Q109, 209)	transistor	2SC871
Q309, 409			
Q110, 210)	transistor	2SC870
Q310, 410			
Q111, 211)	transistor	2SC870
Q311, 411			
Q501	transistor	2SD28	
Q502	transistor	2SC870	
Q503	transistor	2SC870	
Q504	transistor	2SC895	
Q505	transistor	2SC895	

D101, 201)	diode,	1T22
D301, 401			
D501	diode,	1T243M	
D502	diode,	CD-2	

COILS

L101, 201)	equalizer, 1.8/1.45 mH
L301, 401		
L102, 202)	trap, 1.8 mH
L302, 402		
L501	1-407-198-21	micro inductor
L502	1-407-198-21	micro inductor
L503	1-407-285	dummy
L504	1-407-285	dummy

Ref. No. Part No. Description

TRANSFORMERS

T101, 201
 T301, 401) 1-427-217 output.
 T501 1-441-714 power
 T502 1-433-149 bias osc.

CAPACITORS

C101, 201)	1-107-131	100pF	50V	silvered mica
C301, 401					
C102, 202)	1-121-748	10μF	25V	electrolytic
C302, 402					
C103, 203)	1-121-398	10μF	25V	electrolytic
C303, 403					
C104, 204)	1-105-821-12	0.001μF	50V	mylar
C304, 404					
C105, 205)	1-105-821-12	0.001μF	50V	mylar
C305, 405					
C106, 206)	1-121-413	100μF	6.3V	electrolytic
C306, 406					
C107, 207)	1-121-409	47μF	16V	electrolytic
C307, 407					
C108, 208)	1-121-398	10μF	25V	electrolytic
C308, 408					
C109, 209)	1-121-416	100μF	25V	electrolytic
C309, 409					
C110, 210)	1-105-843-12	0.068μF	50V	mylar
C310, 410					
C111, 211)	1-121-398	10μF	25V	electrolytic
C311, 411					
C112, 212)	1-121-391	1μF	50V	electrolytic
C312, 412					
C113, 213)	1-121-402	33μF	10V	electrolytic
C313, 413					
C114, 214)	1-105-677-12	0.022μF	50V	mylar
C314, 414					
C115, 215)	1-105-681-12	0.047μF	50V	mylar
C315, 415					
C116, 216)	1-105-679-12	0.033μF	50V	mylar
C316, 416					
C117, 217)	1-105-675-12	0.015μF	50V	mylar
C317, 417					
C118, 218)	1-107-125	56pF	50V	silvered mica
C318, 418					
C119, 219)	1-121-395	4.7μF	25V	electrolytic
C319, 419					
C120, 220)	1-121-406	47μF	3.15V	electrolytic
C320, 420					
C121, 221)	1-127-020	0.22μF	10V	electrolytic
C321, 421					
C122, 222)	1-105-821-12	0.001μF	50V	mylar
C322, 422					
C123, 223)	1-105-673-12	0.01μF	50V	mylar
C323, 423					
C124, 224)	1-105-670-12	0.0056μF	50V	mylar
C324, 424					
C125, 225)	1-105-667-12	0.0033μF	50V	mylar
C325, 425					

<u>Ref. No.</u>	<u>Part No.</u>	<u>Description</u>	
C126, 226 C326, 426)	1-105-669-12	0.0047 μ F	50V mylar
C127, 227 C327, 427)	1-129-702	0.001 μ F	630V polyethylene
C128, 228 C328, 428)	1-141-010	30 ~ 200 pF	trimmer
C129, 229 C329, 429)	1-121-748	10 μ F	25V electrolytic
C130, 230 C330, 430)	1-121-402	33 μ F	10V electrolytic
C131, 231 C331, 431)	1-107-107	10 pF	50V silvered mica
C132, 232 C332, 432)	1-105-679-12	0.033 μ F	50V mylar
C133, 233 C333, 433)	1-121-403	33 μ F	16V electrolytic
C134, 234 C334, 434)	1-105-663-12	0.0015 μ F	50V mylar
C135, 235 C335, 435)	1-121-398	10 μ F	25V electrolytic
C136, 236 C336, 436)	1-121-416	100 μ F	25V electrolytic
C137, 237 C337, 437)	1-121-391	1 μ F	50V electrolytic
C138, 238 C338, 438)	1-105-670-12	0.0056 μ F	50V mylar
C139, 239 C339, 439)	1-105-663-12	0.0015 μ F	50V mylar
C140, 240 C340, 440)	1-105-665-12	0.0022 μ F	50V mylar
C141, 241 C341, 441)	1-107-242	390 pF	50V silvered mica
C142, 242 C342, 442)	1-121-406	47 μ F	3.15V electrolytic
C143, 243 C343, 443)	1-121-395	4.7 μ F	25V electrolytic
C144, 244 C344, 444)	1-121-406	47 μ F	3.15V electrolytic
C145, 245 C345, 445)	1-121-391	1 μ F	50V electrolytic
C146, 246 C346, 446)	1-121-398	10 μ F	25V electrolytic
C147, 247 C347, 447)	1-121-391	1 μ F	50V electrolytic
C148, 248 C348, 448)	1-107-123	47 pF	50V silvered mica
C149, 249 C349, 449)	1-107-131	100 pF	50V silvered mica
C150, 250 C350, 450)	1-102-106	100 pF	50V ceramic
C151, 251 C351, 451)	1-102-106	100 pF	50V ceramic
C501	1-121-388	1,000 μ F	35V electrolytic
C502	1-121-388	1,000 μ F	35V electrolytic
C503	1-121-738	10 μ F	50V electrolytic
C504	1-121-810	470 μ F	50V electrolytic
C505		- discarded -	

<u>Ref. No.</u>	<u>Part No.</u>	<u>Description</u>	
C506	1-105-759-12	0.033 μ F	200V mylar
C507	1-105-759-12	0.033 μ F	200V mylar
C508	1-121-396	4.7 μ F	50V electrolytic
C509	1-105-845-12	0.1 μ F	50V mylar
C510	1-129-702	0.001 μ F	630V polyethylene
C511	1-129-706	0.0022 μ F	630V polyethylene
C512		- discarded -	
C513	1-129-711	0.0056 μ F	630V polyethylene
C514	1-117-036	1.5+0.5 μ F	250V MP
C515	1-105-845-12	0.1 μ F	50V mylar
C516	1-105-845-12	0.1 μ F	50V mylar
C517	1-107-131	100 pF	50V silvered mica
C518	1-107-131	100 pF	50V silvered mica

RESISTORS

R101, 201 R301, 401)		- discarded -	
R102, 202 R302, 402)	1-244-681	2.2 k Ω	1/4W carbon
R103, 203 R303, 403)	1-222-305	100 k Ω (A)	variable; AUX
R104, 204 R304, 404)	1-244-707	27 k Ω	1/4W carbon
R105, 205 R305, 405)	1-242-673	1 k Ω	1/4W carbon (low-noise)
R106, 206 R306, 406)	1-242-715	56 k Ω	1/4W carbon (low-noise)
R107, 207 R307, 407)	1-242-713	47 k Ω	1/4W carbon (low-noise)
R108, 208 R308, 408)	1-242-699	12 k Ω	1/4W carbon (low-noise)
R109, 209 R309, 409)	1-242-717	68 k Ω	1/4W carbon (low-noise)
R110, 210 R310, 410)	1-242-687	3.9 k Ω	1/4W carbon (low-noise)
R111, 211 R311, 411)	1-242-717	68 k Ω	1/4W carbon (low-noise)
R112, 212 R312, 412)	1-242-716	62 k Ω	1/4W carbon (low-noise)
R113, 213 R313, 413)	1-242-651	120 Ω	1/4W carbon
R114, 214 R314, 414)	1-242-689	4.7 k Ω	1/4W carbon (low-noise)
R115, 215 R315, 415)	1-242-665	470 Ω	1/4W carbon
R116, 216 R316, 416)	1-242-715	56 k Ω	1/4W carbon (low-noise)
R117, 217 R317, 417)	1-242-725	150 k Ω	1/4W carbon
R118, 218 R318, 418)	1-222-306	20 k Ω (A)	variable; MIC
R119, 219 R319, 419)	1-242-725	150 k Ω	1/4W carbon
R120, 220 R320, 420)	1-242-741	680 k Ω	1/4W carbon (low-noise)
R121, 221 R321, 421)	1-242-741	680 k Ω	1/4W carbon (low-noise)

<u>Ref. No.</u>	<u>Part No.</u>	<u>Description</u>		<u>Ref. No.</u>	<u>Part No.</u>	<u>Description</u>	
R122, 222 R322, 422)	1-242-701	15 kΩ	¼W carbon (low-noise)	R151, 251 R351, 451)	1-221-978	4.7 kΩ (B)	semi-fixed
R123, 223 R323, 423)	1-242-659	270 Ω	¼W carbon	R152, 252 R352, 452)	1-242-657	220 Ω	¼W carbon
R124, 224 R324, 424)	1-221-978	4.7 kΩ (B)	semi-fixed	R153, 253 R353, 453)	1-242-711	39 kΩ	¼W carbon
R125, 225 R325, 425)	1-242-737	470 kΩ	¼W carbon (low-noise)	R154, 254 R354, 454)	1-242-691	5.6 kΩ	¼W carbon
R126, 226 R326, 426)	1-242-712	43 kΩ	¼W carbon (low-noise)	R155, 255 R355, 455)	1-242-737	470 kΩ	¼W carbon
R127, 227 R327, 427)	1-242-717	68 kΩ	¼W carbon (low-noise)	R156, 256 R356, 456)	1-242-691	5.6 kΩ	¼W carbon
R128, 228 R328, 428)	1-242-685	4.7 kΩ	¼W carbon	R157, 257 R357, 457)	1-242-737	470 kΩ	¼W carbon
R129, 229 R329, 429)	1-242-665	470 Ω	¼W carbon	R158, 258 R358, 458)	1-242-735	390 kΩ	¼W carbon (low-noise)
R130, 230 R330, 430)	1-242-713	47 kΩ	¼W carbon	R159, 259 R359, 459)	1-242-707	27 kΩ	¼W carbon (low-noise)
R131, 231 R331, 431)	1-242-709	33 kΩ	¼W carbon	R160, 260 R360, 460)	1-242-723	120 kΩ	¼W carbon
R132, 232 R332, 432)	1-242-631	18 Ω	¼W carbon	R161, 261 R361, 461)	1-242-683	2.7 kΩ	¼W carbon
R133, 233 R333, 433)	1-242-683	2.7 kΩ	¼W carbon	R162, 262 R362, 462)	1-242-665	470 Ω	¼W carbon
R134, 234 R334, 434)	1-242-661	330 Ω	¼W carbon	R163, 263 R363, 463)	1-242-719	82 kΩ	¼W carbon
R135, 235 R335, 435)	1-242-679	1.8 kΩ	¼W carbon	R164, 264 R364, 464)	1-242-725	150 kΩ	¼W carbon
R136, 236 R336, 436)	1-242-693	6.8 kΩ	¼W carbon	R165, 265 R365, 465)	1-242-717	68 kΩ	¼W carbon
R137, 237 R337, 437)	1-242-681	2.2 kΩ	¼W carbon	R166, 266 R366, 466)	1-242-713	47 kΩ	¼W carbon
R138, 238 R338, 438)	1-242-673	1 kΩ	¼W carbon (low-noise)	R167, 267 R367, 467)	1-242-691	5.6 kΩ	¼W carbon
R139, 239 R339, 439)	1-242-743	820 kΩ	¼W carbon (low-noise)	R168, 268 R368, 468)	1-242-673	1 kΩ	¼W carbon
R140, 240 R340, 440)	1-242-715	56 kΩ	¼W carbon (low-noise)	R169, 269 R369, 469)	1-242-709	33 kΩ	¼W carbon
R141, 241 R341, 441)	1-242-649	100 Ω	¼W carbon	R170, 270 R370, 470)	1-242-737	470 kΩ	¼W carbon
R142, 242 R342, 442)	1-242-721	100 kΩ	¼W carbon	R171, 271 R371, 471)	1-242-681	2.2 kΩ	¼W carbon
R143, 243 R343, 443)	1-242-733	330 kΩ	¼W carbon (low-noise)	R172, 272 R372, 472)	1-221-748	5 kΩ (B)	semi-fixed
R144, 244 R344, 444)	1-242-697	10 kΩ	¼W carbon (low-noise)	R173, 273 R373, 473)		– discarded –	
R145, 245 R345, 445)	1-242-735	390 kΩ	¼W carbon (low-noise)	R174, 274 R374, 474)	1-242-685	3.3 kΩ	¼W carbon
R146, 246 R346, 446)	1-221-978	4.7 kΩ (B)	semi-fixed	R175, 275 R375, 475)	1-242-637	33 Ω	¼W carbon
R147, 247 R347, 447)	1-221-978	4.7 kΩ (B)	semi-fixed				
R148, 248 R348, 448)	1-242-705	22 kΩ	¼W carbon	R501	1-242-641	47 Ω	¼W carbon
R149, 249 R349, 449)	1-242-701	15 kΩ	¼W carbon	R502	1-242-641	47 Ω	¼W carbon
R150, 250 R350, 450)	1-242-693	6.8 kΩ	¼W carbon	R503	1-242-719	82 kΩ	¼W carbon
				R504	1-221-664	100 kΩ (B)	semi-fixed
				R505	1-242-709	33 kΩ	¼W carbon
				R506	1-242-713	47 kΩ	¼W carbon
				R507	1-244-835	27 Ω	¼W carbon

<u>Ref. No.</u>	<u>Part No.</u>	<u>Description</u>
R508	1-242-617	4.7 Ω $\frac{1}{4}$ W carbon
R509	1-242-617	4.7 Ω $\frac{1}{4}$ W carbon
R510		— discarded —
R511	1-202-411	15 k Ω $\frac{1}{4}$ W composition
R512	1-202-258	33 Ω 1W composition
R513	1-244-601	1 Ω $\frac{1}{4}$ W carbon

JACKS

J101, 201 J301, 401	1-507-251	miniature; MIC
J501	1-507-282	binaural; HEADPHONE
J502	1-507-282	binaural; HEADPHONE
CNJ101 CNJ201 CNJ301 CNJ401 CNJ102 CNJ202 CNJ302 CNJ402	1-507-142	phono, 2-p; AUX IN
CNJ501 CNP501	1-507-323 1-506-312	connector (JACK) connector (PLUG)

SWITCHES

S101, 201 S301, 401	1-514-771	rotary; EQUALIZER
D102, 202 D302, 402	1-514-640	toggle; MONITOR
S103, 203 S303, 403	1-514-641	toggle; NOISE SUPPRESS
S104, 204	1-514-453-21	slide; RECORD
S105, 205 S305, 405	1-514-773	rotary; wafer; MUTING
S106, 206 S306, 406	1-514-642	toggle; TAPE SELECTOR
S501	1-514-231	micro; BIAS ON/OFF
S502	1-514-041	leaf; BIAS timing

<u>Ref. No.</u>	<u>Part No.</u>	<u>Description</u>
S503	1-514-039	micro; MOTOR
S504	1-514-655-11	seesaw; POWER ON/OFF
S505	1-514-771	rotary; EQUALIZER
S506	1-514-512	rotary; frequency change

HEADS

RH101, 201 RH301, 401	8-824-509-40	record (RP77-2904)
PH101, 201 PH301, 401	8-822-542-40	playback (PP77-4204)
EH101, 201 EH301, 401	8-825-501-00	erase (EF72-2904H1)

LAMPS

PL101, 201 PL301, 401	1-518-093-21	record, 100 mA
PL501	1-518-093-21	power, 100 mA

ENCAPSULATED COMPONENTS C-R

CP501	1-101-534	0.1 μ F + 120 Ω
CP502	1-231-057	0.033 μ F + 120 Ω

MISCELLANEOUS

ME101, 201 ME301, 401	1-524-062	meter, level
M	8-832-624-09	motor (IC-624H1)
	1-534-487-22	cord, power
	1-535-506	terminal; joint
	1-536-146	terminal strip; 1-L-1
	1-536-179	terminal strip; 1-L-1
	1-536-180	terminal strip; 1-L-2
	1-536-181	terminal strip; 2-L-1
F	1-532-096	fuse, 0.8A
	1-533-006	holder, fuse
	1-509-064	switch, voltage selector

14. EXPLODED VIEW

14-1. Packing

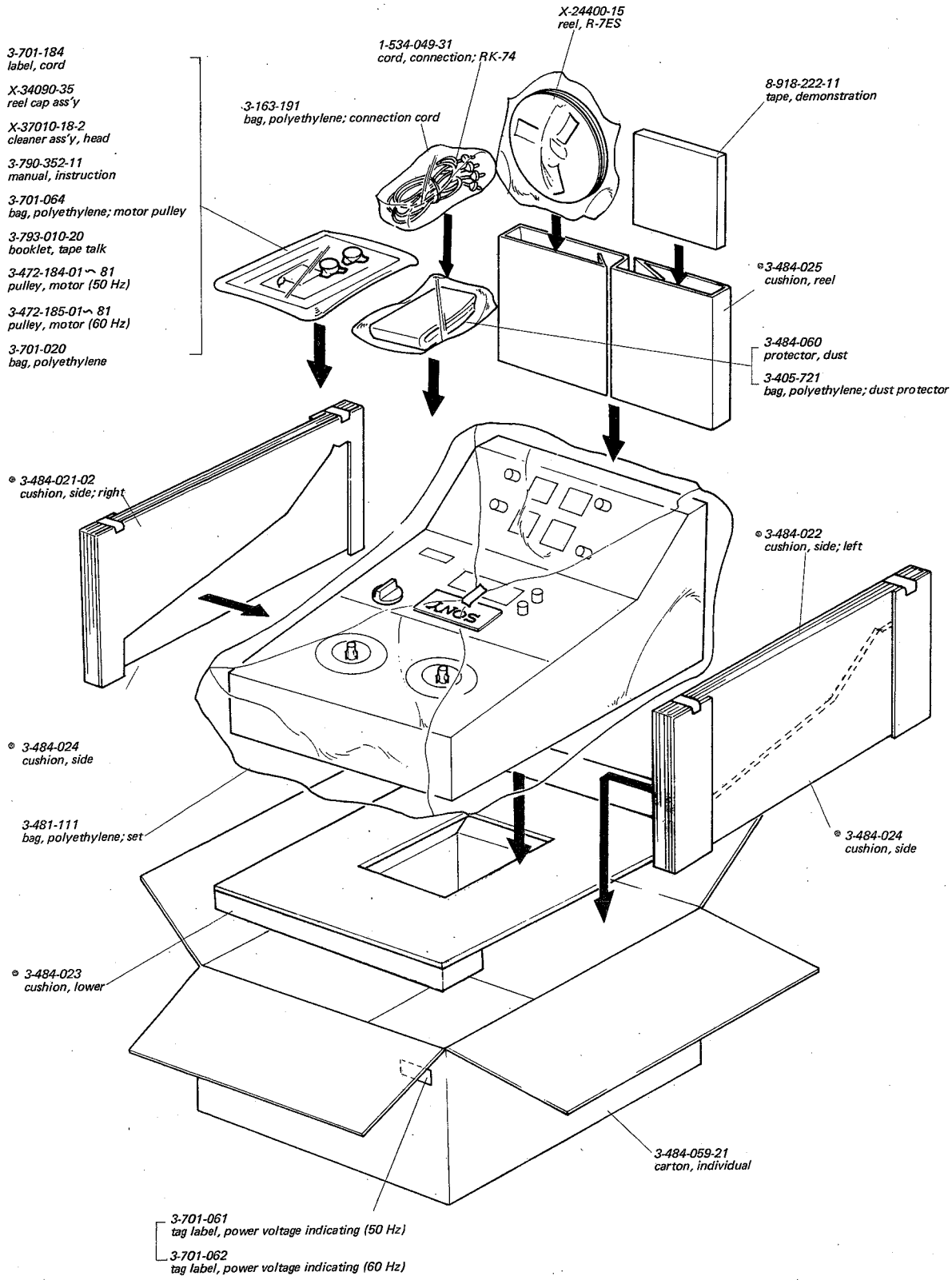

Parts marked © are included in cushion ass'y (X-34840-10).

14-2. Cabinet — top view —

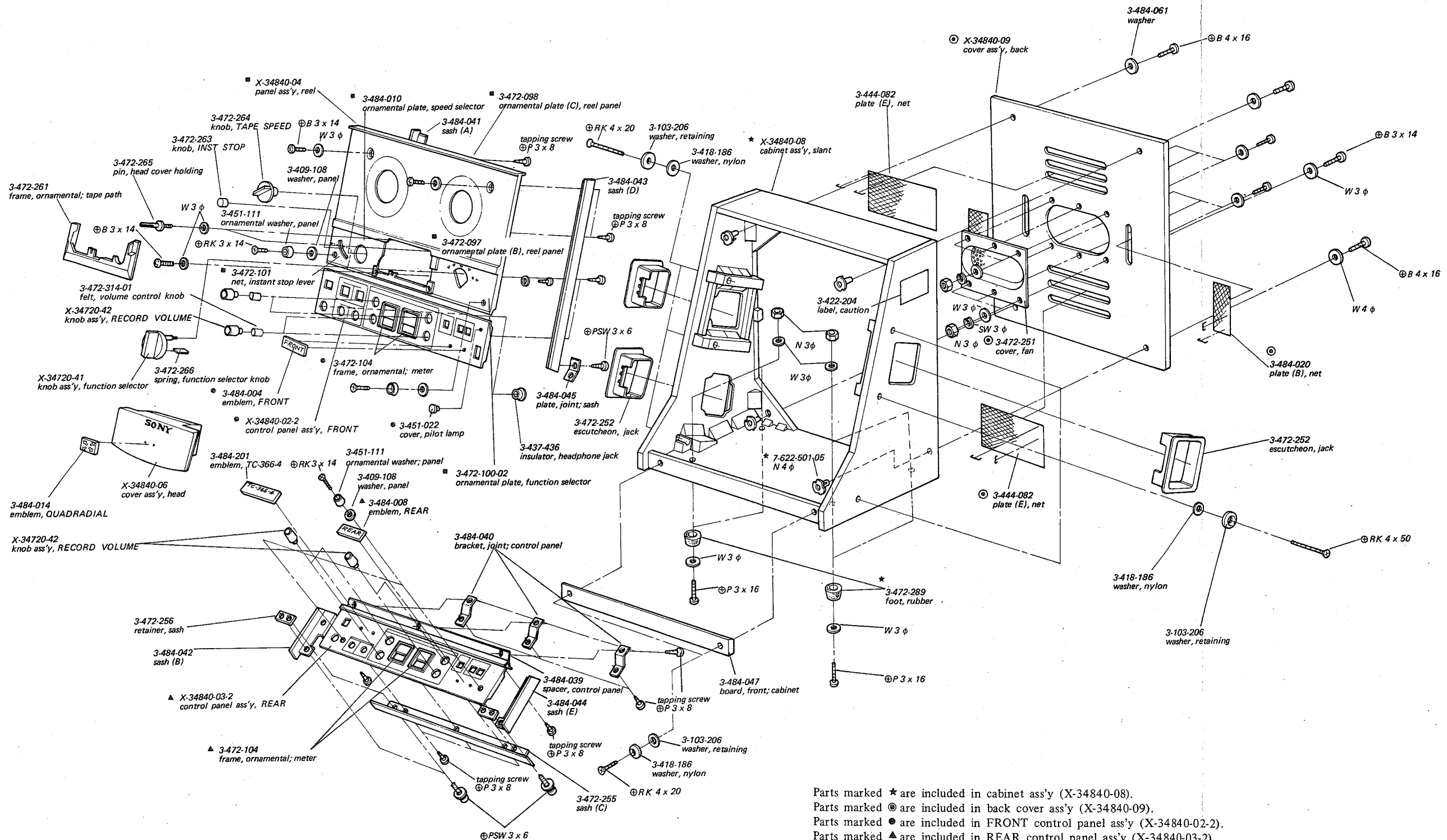

Parts marked * are included in cabinet ass'y (X-34840-08).
 Parts marked ⊙ are included in back cover ass'y (X-34840-09).
 Parts marked ⊚ are included in FRONT control panel ass'y (X-34840-02-2).
 Parts marked ▲ are included in REAR control panel ass'y (X-34840-03-2).
 Parts marked ■ are included in reel panel ass'y (X-34840-04).

14-5. Amplifier Chassis – REAR –

(1)

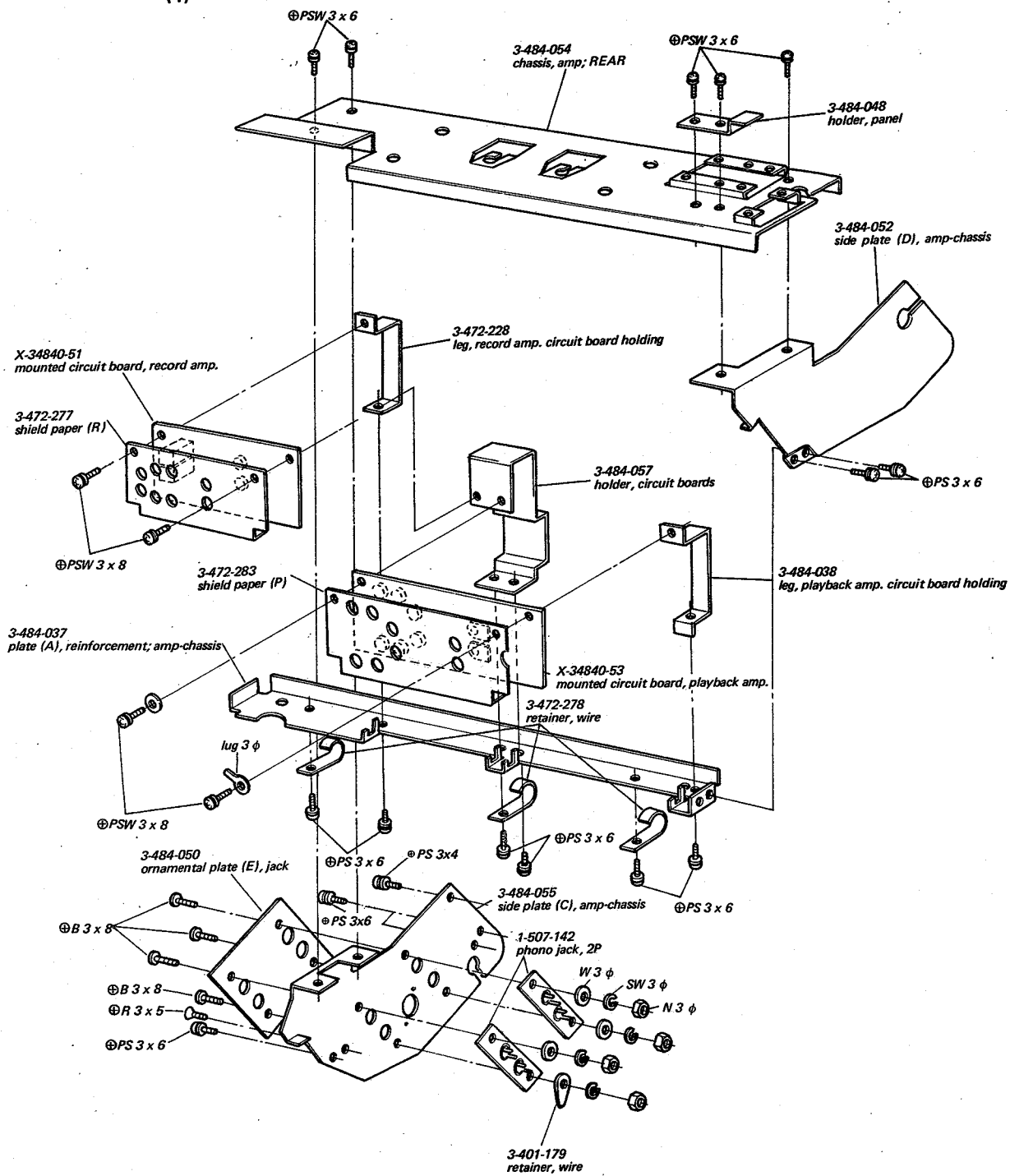

14-6. Amplifier Chassis – REAR –

(2)

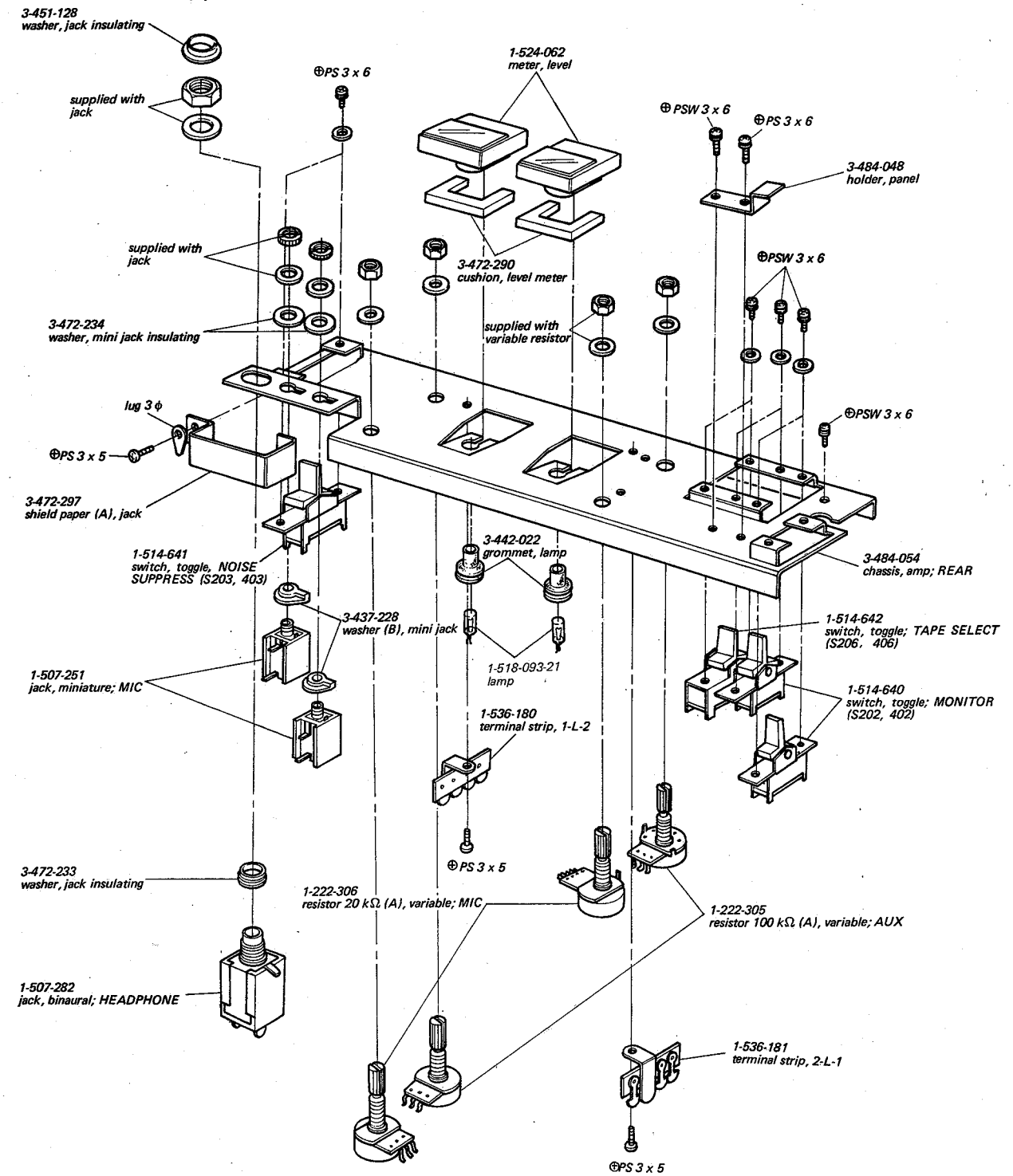

14-7. Head Deck — top view —

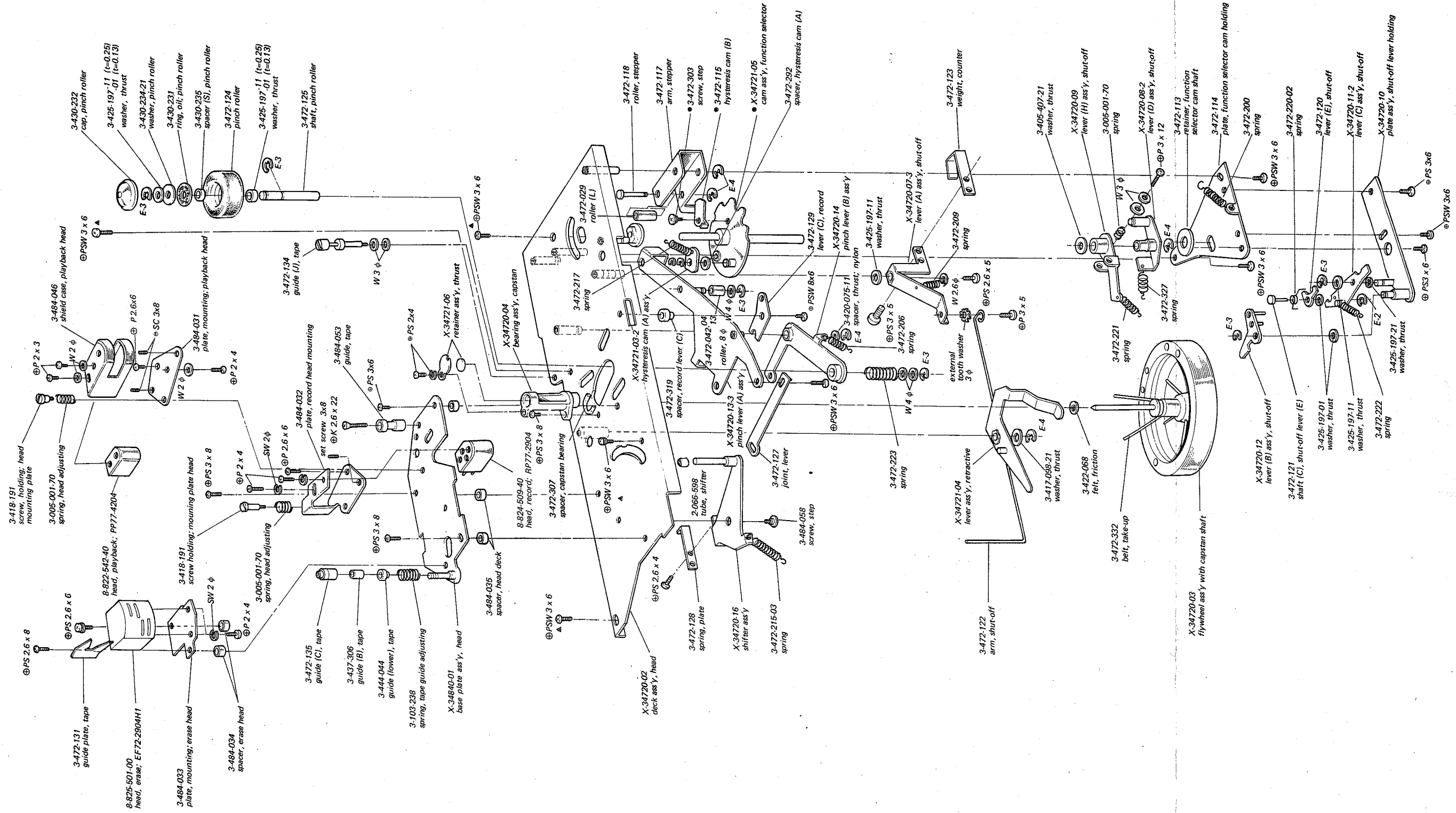

Parts marked ● are included in function selector cam ass'y (X-34721-05).

15. HARDWARES

Part No.	Description	Part No.	Description
SCREWS			
7-621-259-25	⊕ P 2.6 x 4	7-683-141-21	⊖ SC 3 x 8
7-621-259-42	⊕ P 2.6 x 6	7-683-242-31	3 x 10, lock w/hexagonal
7-621-259-52	⊕ P 2.6 x 8	7-683-247-31	4 x 6, lock w/hexagonal
7-621-259-62	⊕ P 2.6 x 10	7-685-133-01	⊕ P 2.6 x 6, self tapping
7-621-259-72	⊕ P 2.6 x 12	7-685-145-31	⊕ P 3 x 6, self tapping
7-621-560-32	⊕ K 2.6 x 22	7-685-146-31	⊕ P 3 x 8, self tapping
7-621-771-38	⊕ B 2.6 x 8	7-685-146-01	⊕ P 3 x 8, self tapping
7-628-253-22	⊕ PS 2.6 x 10, w/spring washer	NUTS	
7-628-253-32	⊕ PS 2.6 x 10, w/spring washer	7-622-108-02	N 3φ
7-628-254-12	⊕ PS 2.6 x 6, w/spring washer	7-622-501-06	N 4φ, with claw
7-628-254-22	⊕ PS 2.6 x 8, w/spring washer	WASHERS	
7-681-124-13	⊕ P 2 x 4	7-623-104-11	W 1.7φ (middle)
7-682-145-01	⊕ P 3 x 4	7-623-105-22	W 2φ (large)
7-682-148-01	⊕ P 3 x 8	7-623-107-02	W 2.6φ (small)
7-682-149-01	⊕ P 3 x 10	7-623-107-22	W 2.6φ (large)
7-682-160-01	⊕ P 4 x 6	7-623-108-02	W 3φ (small)
7-682-246-01	⊕ K 3 x 5	7-623-108-12	W 3φ (middle)
7-682-348-14	⊕ RK 3 x 8	7-623-108-18	W 3φ (middle)
7-682-351-14	⊕ RK 3 x 14	7-623-110-02	W 4φ (small)
7-682-352-14	⊕ RK 3 x 16	7-623-110-12	W 4φ (middle)
7-682-366-05	⊕ RK 4 x 20	7-623-113-12	W 6φ
7-682-372-05	⊕ RK 4 x 50	7-623-205-26	SW 2φ
7-682-548-13	⊕ B 3 x 8	7-623-207-22	SW 2.6φ
7-682-550-13	⊕ B 3 x 12	7-623-208-22	SW 3φ
7-682-551-14	⊕ B 3 x 14		8φ, wave
7-682-562-13	⊕ B 4 x 10	7-623-408-05	LW 3φ (external)
7-682-565-03	⊕ B 4 x 16	7-623-508-21	LW 3φ
7-682-624-00	⊕ PS 2 x 4, w/spring washer	RETAINING RINGS	
7-682-627-00	⊕ PS 2 x 8, w/spring washer	7-624-104-01	E-2
7-682-646-00	⊕ PS 3 x 5, w/spring washer	7-624-106-01	E-3
7-682-647-00	⊕ PS 3 x 6, w/spring washer	7-624-108-01	E-4
7-682-648-00	⊕ PS 3 x 8, w/spring washer	7-624-109-01	E-5
7-682-652-00	⊕ PS 3 x 16, w/spring washer	7-624-111-01	E-7
7-682-660-00	⊕ PS 4 x 6, w/spring washer	7-624-112-01	E-8
7-682-661-00	⊕ PS 4 x 8, w/spring washer		
7-682-947-01	⊕ PSW 3 x 6		
7-682-948-01	⊕ PSW 3 x 8		

Hardware Nomenclature

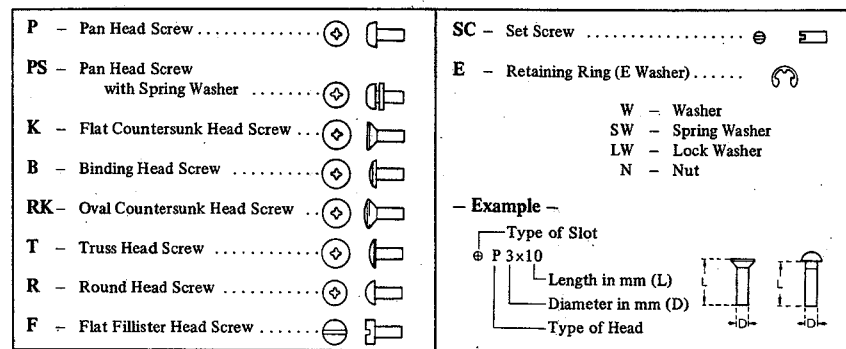

16. CONVERSION TO DIFFERENT POWER LINE FREQUENCY

If the deck is to be operated on a line frequency different from the frequency for which the deck is adjusted, it may be easily converted. (Remove the reel panel for access.)

FIRST: Using a screw-driver, turn the line frequency switch (S506) to the correct position for the power to be used (50 or 60 Hz). See Fig. 16-1.

SECOND: Replace the motor pulley as follows:

1. Remove the Instant Stop adjusting plate and withdraw the Instant Stop pull rod.
2. Remove the two screws which hold the motor pulley and take off the pulley of its shaft.

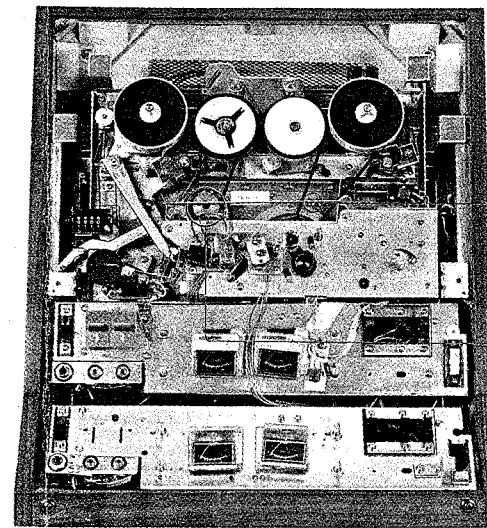

Fig. 16-1

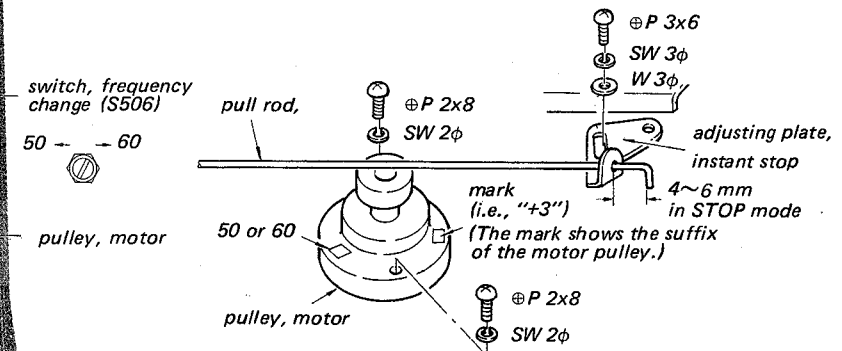

Fig. 16-2

Motor Pulley Part No.			
for 50 Hz		for 60 Hz	
Identification Mark on Motor Pulley	Part No.	Identification Mark on Motor Pulley	Part No.
+3	3-472-184-61	+3	3-472-185-61
+2	3-472-184-51	+2	3-472-185-51
+1	3-472-184-41	+1	3-472-185-41
+0.5	3-472-184-71	+0.5	3-472-185-71
0	3-472-184-01	0	3-472-185-01
-0.5	3-472-184-81	-0.5	3-472-185-81
-1	3-472-184-11	-1	3-472-185-11
-2	3-472-184-21	-2	3-472-185-21
-3	3-472-184-31	-3	3-472-185-31

Sony Corporation

© 1970

- 62 -