

61186
Original

TC-558



R0833 USA Model
Canada Model
PX Model

STEREO TAPECORDER

SPECIFICATIONS

Power Requirements: 120 V ac, 50/60 Hz (USA, Canada Model)
120 V ac, (100, 110, 127, 220, 240 V ac adjustable by authorized Sony personnel), 50/60 Hz (PX Model)

Power Consumption: 70 W (MITI standards)
100 W (CSA, UL and IEC standards)

Track System: 4 tracks, 2 channel stereo or monaural

Reels: 178 mm (7 inches) or smaller

Tape Speeds: 19 cm/s (7½ ips), 9.5 cm/s (3¾ ips)

Frequency Response: NAB: (USA, Canada, PX Model)

tape speed	with normal tape	with SONY SLH tape
19 cm/s (7½ ips)	20~25,000 Hz 30~20,000 Hz (±3 dB)	20~30,000 Hz 30~25,000 Hz (±3 dB)
9.5 cm/s (3¾ ips)	20~17,000 Hz	20~20,000 Hz

DIN: (PX Model)

tape speed	with normal tape	with SONY SLH tape
19 cm/s (7½ ips)	30~20,000 Hz	30~25,000 Hz
9.5 cm/s (3¾ ips)	30~13,000 Hz	30~15,000 Hz

S/N Ratio: 56 dB (with SONY SLH tape)
53 dB (with normal tape)

Wow and Flutter: NAB: (USA, Canada, PX Model)
0.05 % at 19 cm/s (7½ ips)
0.09 % at 9.5 cm/s (3¾ ips)
WRMS
DIN: (PX Model)
±0.09 % at 19 cm/s (7½ ips)
±0.12 % at 9.5 cm/s (3¾ ips)

Harmonic Distortion: 1.2 %

Inputs: MICROPHONE (phone jack) . . . 2
Sensitivity 0.2 mV (-72 dB)
Accept low impedance microphones.

LINE IN (phono jack) 2
Sensitivity 0.06 V (-22 dB)
Impedance 100 kΩ

REC/PB (DIN jack) . . (PX Model only)
Impedance lower than 10 kΩ

Outputs: LINE OUT (phono-jack) 2
Output level 0.43 V (-5 dB) at load impedance of 100 kΩ, with PB LEVEL controls set to the center detent position (0.775 V = 0 dB . . . with PB LEVEL controls set to MAX.)
Suitable load impedance higher than 10 kΩ

REC/PB (DIN jack) . . (PX Model only)
Output level 0.775 V (0 dB) with PB LEVEL controls set to the center detent position
Impedance lower than 10 kΩ

HEADPHONE (stereo binaural jack) 1
accepts 8 Ω stereo headphones.

Dimensions: 458 (w) x 425 (h) x 213 (d) mm
18 1/8 (w) x 16 3/4 (h) x 8 1/2 (d) inches including projecting parts and controls

Weight: 20.8 kg (45 lb 14 oz)

SONY®

SERVICE MANUAL

Original

SECTION 1

OUTLINE

1-1. BLOCK DIAGRAM

- Amp Section -

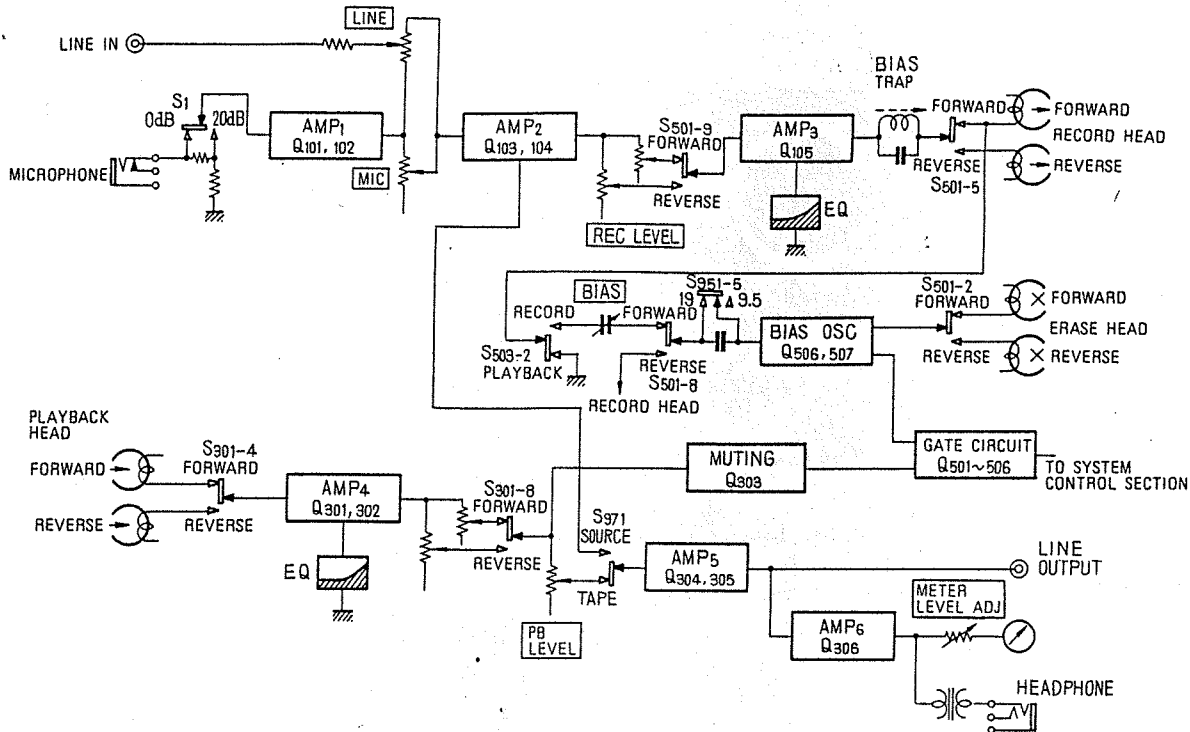

- System Control Section -

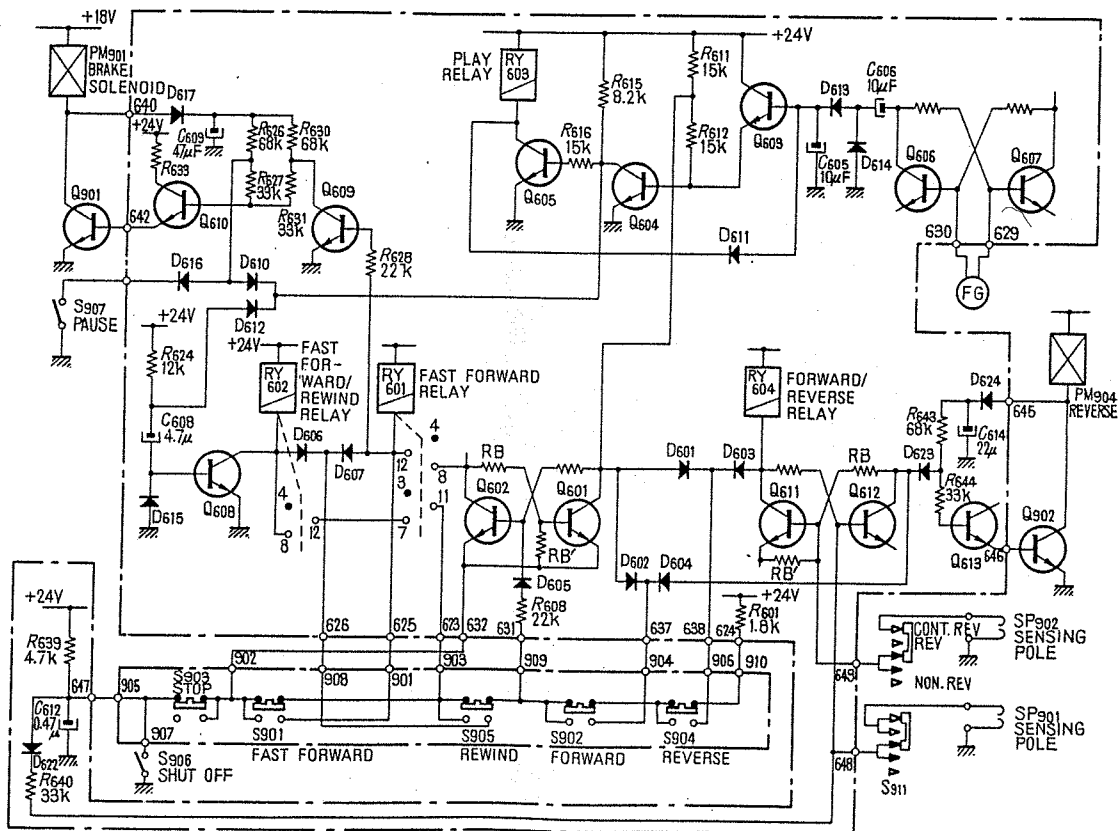

SECTION 2 DISASSEMBLY

CABINET REMOVAL: (1) ~ (10)
 AMP PANEL AND REEL
 PANEL REMOVAL: (11) ~ (24)

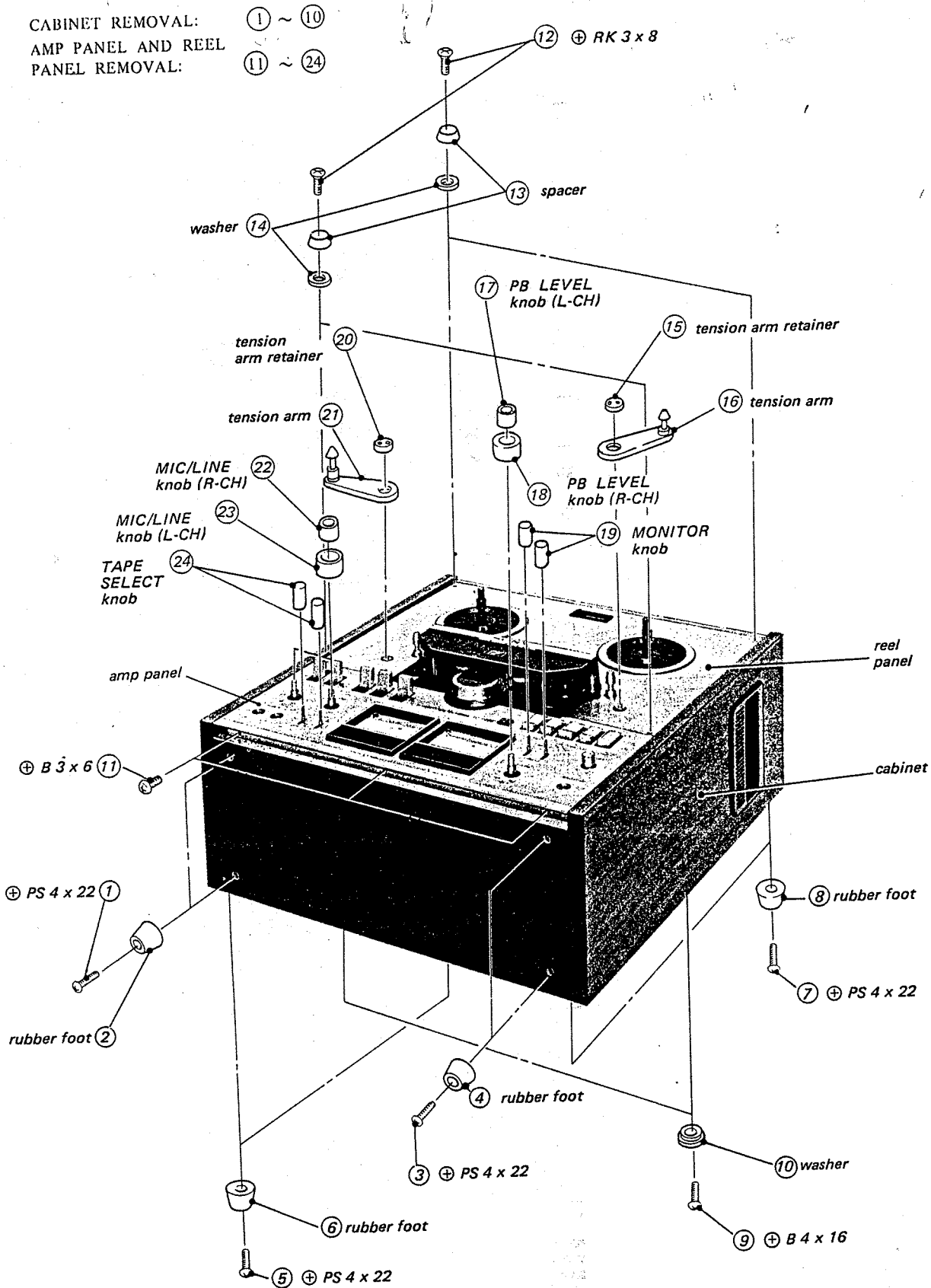

SECTION 3
ADJUSTMENTS

3-1. MECHANICAL ADJUSTMENTS

Brake Torque Adjustment
— stop mode —

Set the brake lever by moving the brake arm as shown.

Change the hooking position of the spring for the specified brake torque.

Specification:

Take-up Reel	Supply Reel	Brake Torque
clockwise	counter-clockwise	1000 ~ 1400 g.cm (13.9 ~ 19.5 oz.-inch)
counter-clockwise	clockwise	300 ~ 400 g.cm (4.17 ~ 5.55 oz.-inch)

Reel Table Height Adjustment

1. Thread a 7-inch tape.
2. Make sure that the tape does not touch the reel flanges in forward playback, reverse playback, fast forward and rewind modes.
3. If the tape touches the reel flanges, adjust the reel table height by loosening the two adjustment screws.

Pinch Roller Pressure Adjustment
— playback mode —

1. Hook the spring scale to the base of the pinch roller shaft.
2. Pull the spring scale in the counter direction of the capstan.
3. Allow the pinch roller to return slowly and measure the pressure (spring scale tension) at the point where the pinch roller just contacts the capstan.

Specification: 1,200 to 1,400 g.cm
(16.7 to 19.4 oz.-inch)

4. If necessary, adjust by turning the adjustment nut (A).
5. Make sure of the clearance indicated by *.
6. After completing the adjustment, apply locking compound to the nuts.

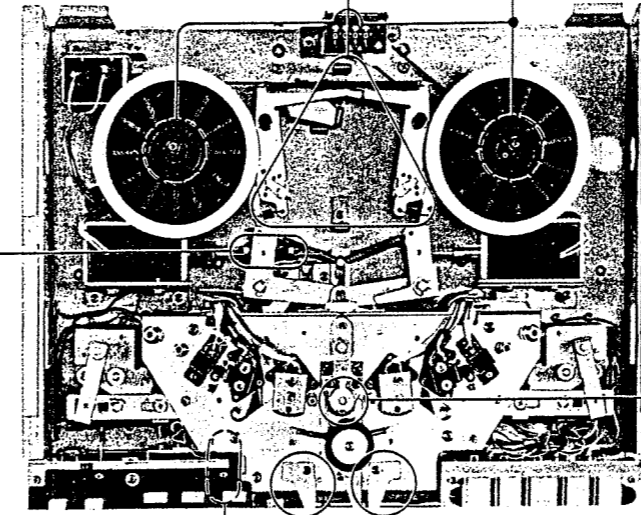

Capstan Shaft Position Adjustment
Test Setup: — forward or reverse playback mode —

Procedures:

1. Loosen the two adjustment screws, and move the pinch roller bracket to left and right, front and back for maximum meter reading.
2. Tighten the adjustment screws.
3. After completing the adjustment, apply locking compound to the adjustment screws.

Pause Lever Adjustment
— forward or reverse playback mode —

1. With PAUSE button pulled, adjust pause lever position by loosening the two adjustment screws so that clearance between pinch roller and capstan is 1 mm ($\frac{1}{32}$ ”).

Note: When the mode is changed from forward playback to reverse playback in PAUSE mode or vice versa, PAUSE button should not be released.

Direction Change Stopper Position Adjustment
— forward and reverse playback modes —

1. Loosen the screws and adjust the direction change stopper position for the clearance shown. Tighten the screws.
2. Make sure of each function in the following order:
forward playback → rewind → stop → reverse playback → stop → forward playback
3. If each function does not smoothly change, readjust by moving the direction change stopper.
4. Apply locking compound to the screws.

Tape Pass Adjustment

a). Tape Guide Adjustment

1. Thread the tape, and set the TAPE SPEED switch to "19 cm".
2. Make sure that the tape is correctly running in forward and reverse playback mode.
3. Make sure that the tape does not curl at the portions indicated by *.

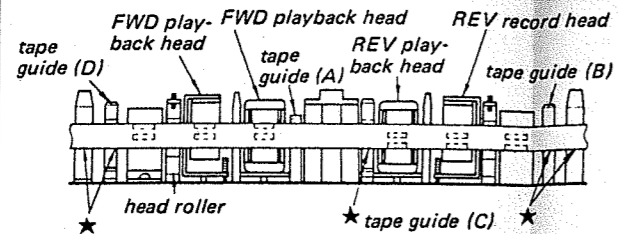

4. If necessary, adjust the tape guides (B), (C) and (D) relative to the tape guide (A).
5. Adjust the both tension arm heights by turning the adjustment screws.

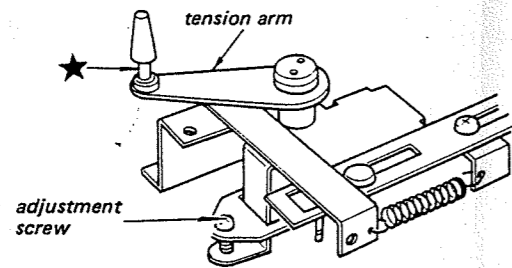

b). Pinch Roller Check

1. Thread a 7-inch tape, and set the TAPE SPEED switch to "19 cm".
2. Make sure that the beginning portion of tape is correctly running, and does not move up and down on the both tape guides near the pinch roller.

c). Head Roller Adjustment

1. Thread a 7-inch tape, and run the tape in forward and reverse playback mode.
2. Make sure that the head roller is rotating, and hold the head roller by fingers.
3. Make sure that the head roller starts rotating again, when taking off fingers from the head roller.
4. Make sure that the tape is not wavy at the head roller.
5. If necessary, adjust the angle of head roller by using the spacer as shown.

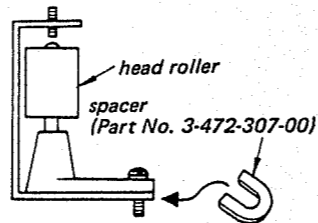

d). Adjustments after Playback and Record Head Replacement

Note: When replacement of both playback and record heads is required, leave one of them unremoved for the reference of adjustments. After one head has been replaced and adjusted, replace the other head. Do not remove all the heads at the same time.

Settings:

- TAPE SELECT switch: BIAS → LOW
EQ → NORMAL
- MONITOR switch: TAPE
- TAPE SPEED switch: 19 cm or 9.5 cm (7 1/2 or 3 3/4)
- PB LEVEL control: mechanical mid normal position (See page 10.)
- LINE control:

2. Mode: record
MONITOR switch: TAPE

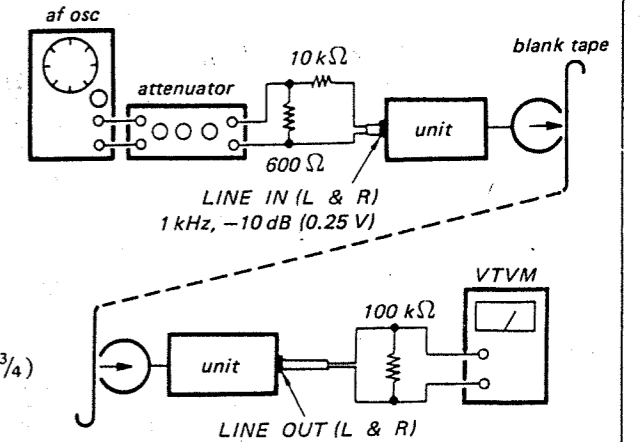

Procedure:

1. Thread a tape, and by turning head zenith and head height adjustment screws, adjust the head height as shown.

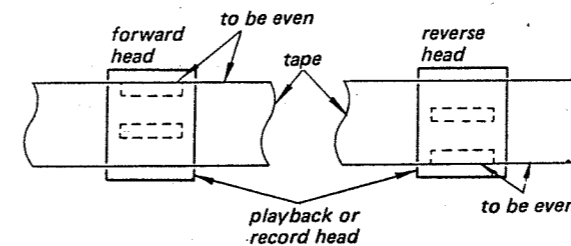

Adjust the head zenith and head height adjustment screws for maximum reading on the VTVM.

3. Perform the playback head azimuth and phase adjustments on Page 13 or the record head azimuth adjustment on Page 15.
4. After completing the adjustment, apply locking compound to the adjustment screws.

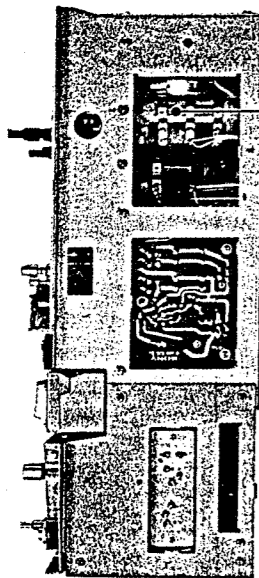

Back Tension Torque Adjustment

1. Measurement

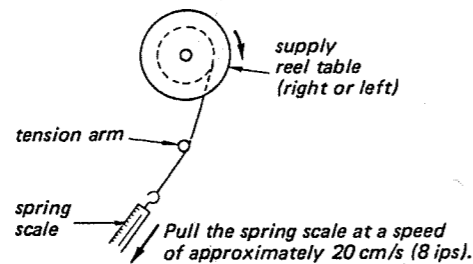

Specifications:

Mode	Back Tension Torque
fast forward, rewind	40 ~ 50 g·cm (0.55 ~ 0.7 oz·inch)
forward, reverse playback	200 ~ 240 g·cm (2.78 ~ 3.34 oz·inch)

2. If necessary, adjust the torque by moving the slider of R901 and R902.

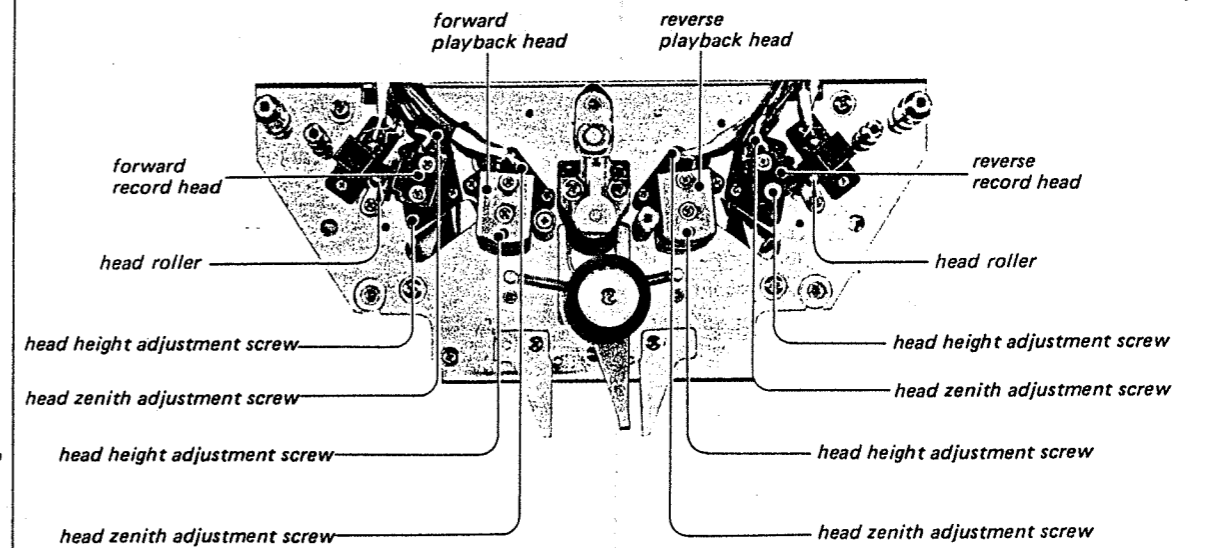
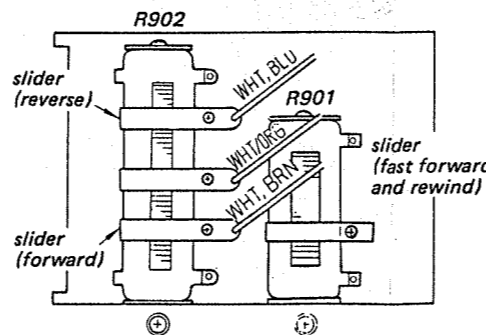

3-2. ELECTRICAL ADJUSTMENTS

Precaution:

- Clean the following parts with a swab moistened with alcohol:

record heads	pinch roller
playback heads	rubber belts
erase heads	idlers
capstan	tape guides
- Demagnetize record, playback and erase heads with a head demagnetizer.
- Do not use magnetized screwdriver for adjustments.
- After adjustments, apply locking compound to the adjusted parts.
- Adjustments should be performed in the order listed in this service manual.
- Adjustments and measurements should be performed for each L and R channel with the rated power supply voltage unless otherwise specified.
- Unless otherwise noted, set controls and switches as follows:

- TAPE SELECT switch ... EQ → NORMAL
 BIAS → LOW
- MONITOR switch ... TAPE
- TAPE SPEED switch ... 19 cm (7½)
- MIC ATT switch ... OFF
- AUTO REV switch ... NON REV

Test Equipment/Tools Required:

- audio oscillator (af osc)
 VTVM
 VOM
 attenuator (600 Ω)
 digital frequency counter
 or speed checker (SONY LFM-30)
 resistors:
 600 Ω, 10 kΩ, 100 kΩ
 SONY test tapes:
 1). J-19-F2

Tone:	1	2	3	4	5	6	7
Frequency (Hz):	400	400	10 k	12.5 k	7 k	80	40
Level (dB):	0	-10	-10	-10	-10	-10	-10

- SPC-47 (4 kHz, 0 dB)
 blank tape (completely erased):
 SLH-S1

Normal Input Level

	Impedance	Level
LINE IN	10 kΩ	-10 dB (0.25 V)

Normal Output Level

	Load Impedance	Level
LINE OUT	100 kΩ	-5 dB (0.44 V)

Normal LINE control setting:

- MIC control: MIN
 PB LEVEL control: mechanical mid
 TAPE SELECT switch: EQ → SLH
 BIAS → LOW
- MONITOR switch: TAPE
- Mode: record

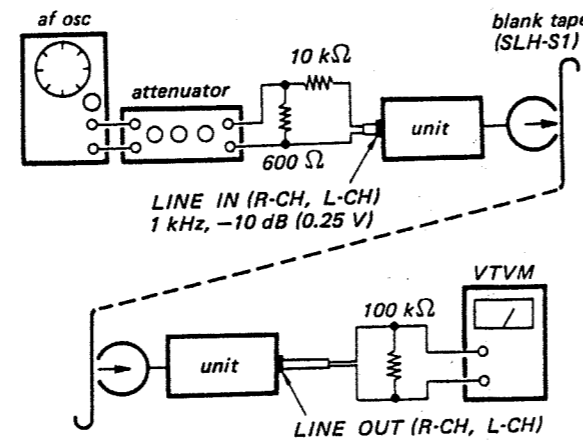

Adjust LINE control for -5 dB (0.44 V) reading on the VTVM.

1. 24 V B⊕ Adjustment

Procedure:

Mode: stop

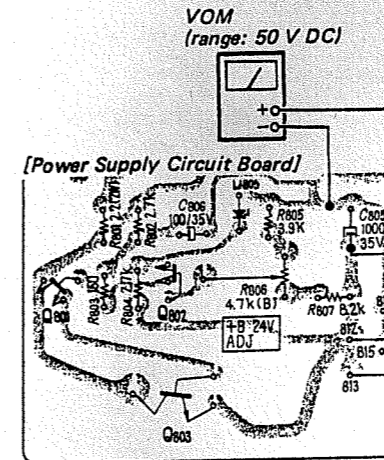

Adjust R806 for 24 V reading on the VOM.

2. Tape Speed Adjustment

Settings:

TAPE SPEED switch: 19 cm and 9.5 cm (7½ and 3¾)

Procedure:

- Mode: playback

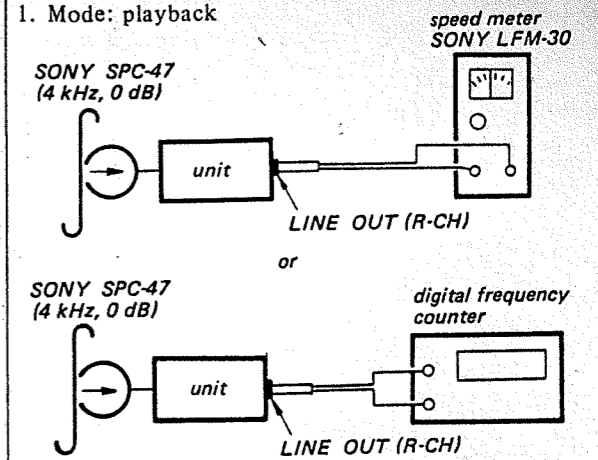

TAPE SPEED	Adjust	Specification	
		speed checker	digital frequency counter
19 cm, 7½	R718	-1 ~ +1 %	3,960 ~ 4,040 Hz
9.5 cm, 3¾	R719	-1 ~ +1 %	1,980 ~ 2,020 Hz

Adjustment Location:

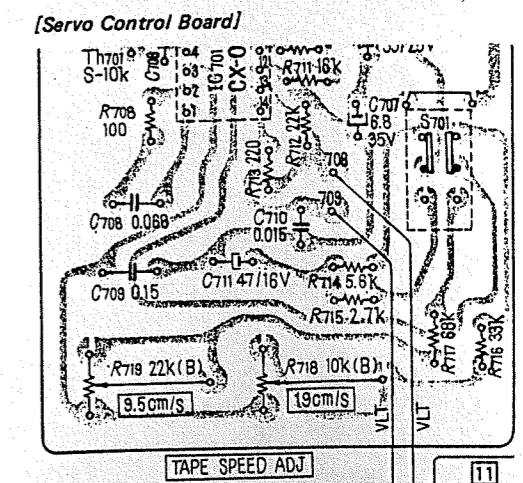

3. Playback Head Azimuth and Phase Adjustments

Settings:

TAPE SPEED switch: 19 cm (7 1/2)

Procedure:

1. Mode: playback

SONY J-19-F2 (3rd tone)
(10 kHz, -10 dB)

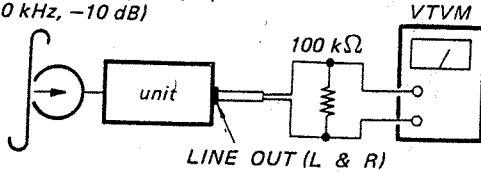

Turn the adjustment screw for the highest reading on the VTVM.

Note: If the highest peak readings at L-CH and R-CH cannot be obtained at the same screw position, take the midway between the both positions of the screw.

2. Mode: playback

SONY J-19-F2 (2nd tone)
(400 Hz, -10 dB)

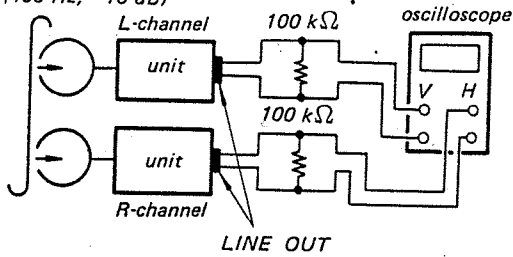

Adjust	On the oscilloscope			
azimuth adjustment screw				
	in-phase	30°	90°	more than 90°
	good		wrong	

Adjustment Location:

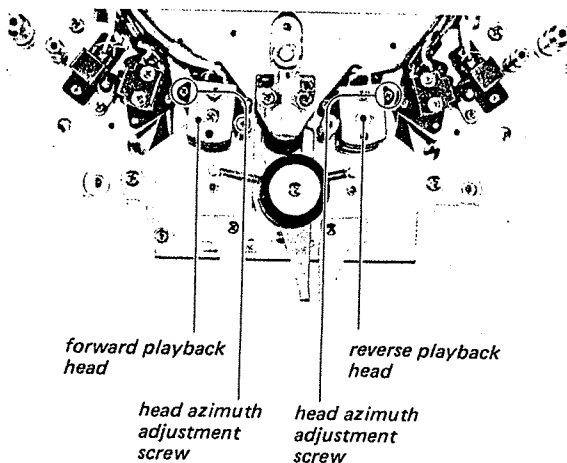

4. Playback Level Adjustment

Procedure:

1. Mode: playback

SONY J-19-F2
(1st tone, 400 Hz 0 dB)

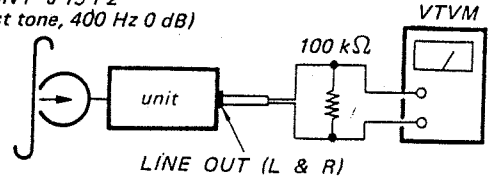

TAPE SELECT (EQ) switch: NORMAL

Mode	Adjust	VTVM reading
forward playback	R316 (L-CH) R416 (R-CH)	-5.5 dB ~ -4.5 dB (0.41 V ~ 0.45 V)
reverse playback	R315 (L-CH) R415 (R-CH)	

TAPE SELECT (EQ) switch: SPECIAL

Mode	Adjust	VTVM reading
forward playback	R316 (L-CH) R416 (R-CH)	-8 dB ~ -7 dB (0.31 V ~ 0.35 V)
reverse playback	R315 (L-CH) R415 (R-CH)	

Adjustment Location:

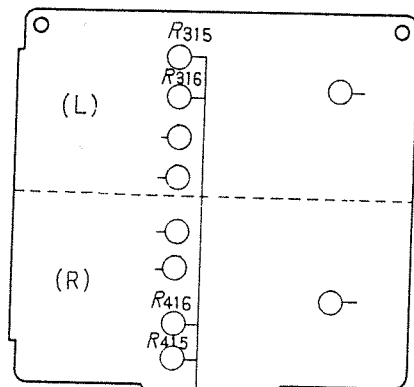

playback level adj.
forward: R316, 416
reverse: R315, 415

playback circuit board
(conductor side)

5. Playback Equalizer Adjustment

Settings:
TAPE SELECT (EQ) switch: SPECIAL

Procedure:

Mode: playback
SONY J-19-F2
(2nd tone, 400 Hz, -10 dB)
(3rd tone, 10 kHz, -10 dB)

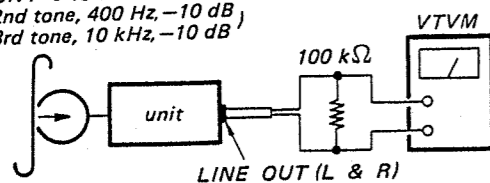

Mode	Adjust	Remarks
forward playback	R314 (L-CH) R414 (R-CH)	Adjust so that 10 kHz level is the same as 400 Hz.
reverse playback	R313 (L-CH) R413 (R-CH)	

Specification:

J-19-F2		Level Difference from 2nd tone (400 Hz)
Tone	Frequency	
2nd	400 Hz	0 dB (reference)
3rd	10 kHz	0 ± 2 dB
4th	12.5 kHz	0 ± 2 dB
5th	7 kHz	0 ± 2 dB
6th	80 Hz	+1 ± 2.5 dB
7th	40 Hz	+3 ± 2.5 dB

Adjustment Location:

playback equalizer adj.
forward: R314, 414
reverse: R313, 413

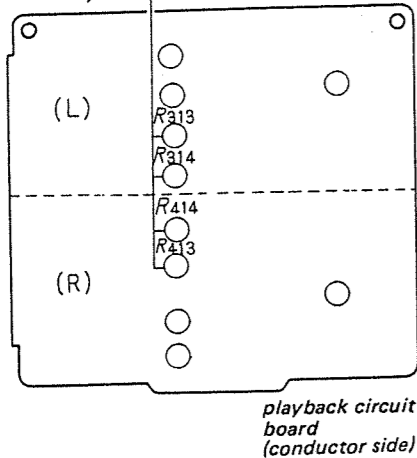

6. Level Meter Calibration

Settings:
MONITOR switch: SOURCE
PB LEVEL control: mechanical mid

Procedure:

1. Mode: record

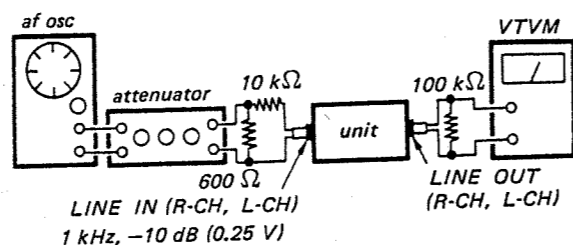

LINE IN (R-CH, L-CH)
1 kHz, -10 dB (0.25 V)

2. Adjust LINE IN control for -5 dB (0.44 V) reading on the VTVM.
3. Calibrate the level meters for "0" indication.

Adjust	Level Meter Reading
R333 (L-CH)	"0" VU
R433 (R-CH)	

Adjustment Location:

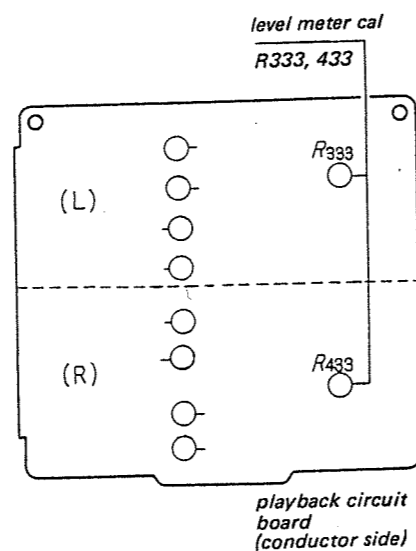

7. Record Head Azimuth Adjustment

Settings:
TAPE SELECT (EQ) switch: SPECIAL
TAPE SELECT (BIAS) switch: LOW
LINE control: normal setting on page 11

Procedure:

1. Mode: record

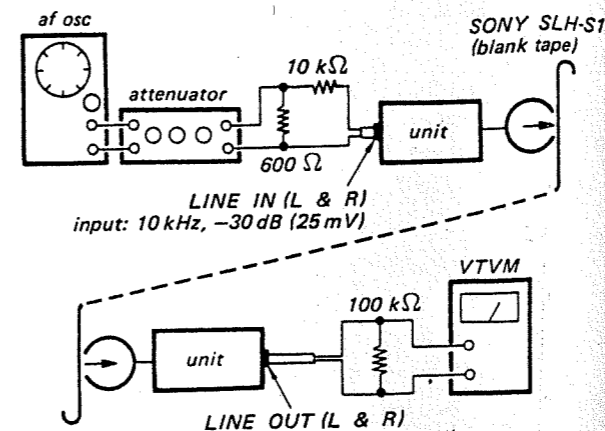

Turn the adjustment screw for the highest reading on the VTVM.

Note: If the highest peak readings at L-CH and R-CH cannot be obtained at the same screw position, take the midway between the both positions of the screw.

Adjustment Location:

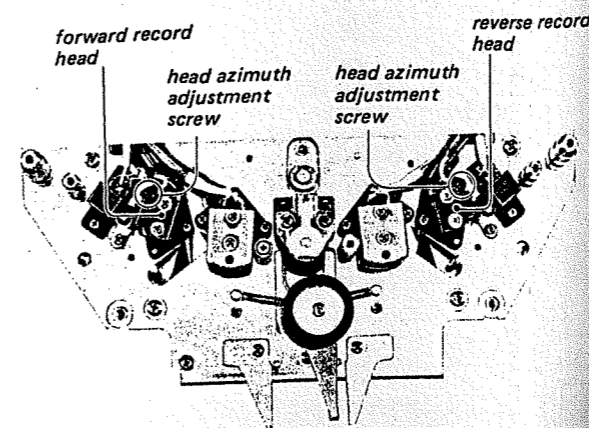

8. Record Bias and Bias Frequency Adjustment

Settings:
TAPE SELECT (EQ) switch: SPECIAL
TAPE SELECT (BIAS) switch: LOW
LINE control: normal setting on page 11

Procedure:

1. Mode: record

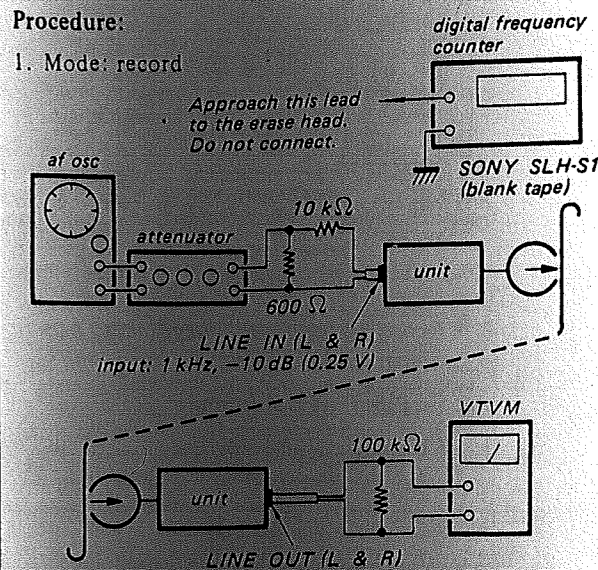

Mode	Adjust	Remarks
forward record	trimmer capacitor C512 (L-CH) C513 (R-CH)	Slowly turn the trimmer capacitor clockwise until VTVM reads 0.5 dB below and beyond the maximum reading as shown.
reverse record	trimmer capacitor C514 (L-CH) C515 (R-CH)	

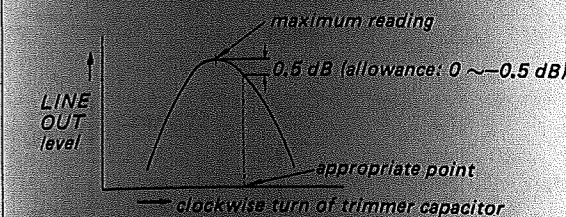

2. In forward record mode, be sure that the frequency counter reading is as specified. Specification: 160 ± 3 kHz
3. In reverse record mode, adjust the trimmer capacitor C508 until VTVM reads the same frequency as step 2.

Adjustment Location: See Fig. A. on next page.

Adjustment Location:

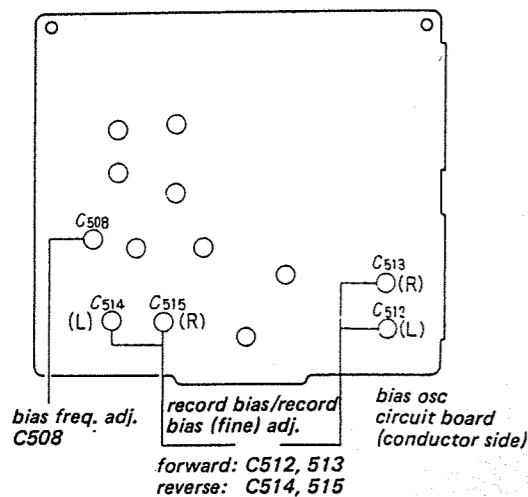

Fig. A. Record bias and frequency, record bias fine adjustment location

9. Record Bias Fine Adjustment

Note: Perform this adjustment after the record bias and bias frequency adjustment.

Settings:

TAPE SELECT (EQ) switch: SPECIAL
 LINE control: normal setting on page 11

Procedure:

1. Mode: record

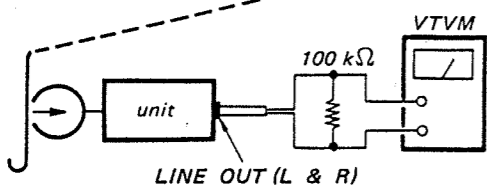
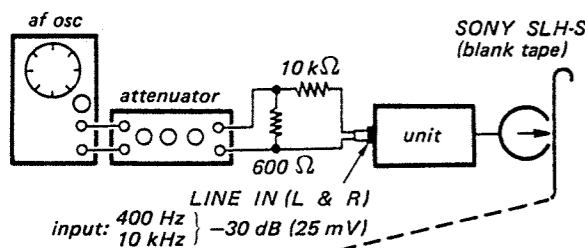

Mode	Frequency	Adjust	Remarks
forward record	400 Hz	trimmer capacitor C512 (L-CH) C513 (R-CH)	Adjust so that 10 kHz level is the same as 400 Hz.
	10 kHz		
reverse record	400 Hz	trimmer capacitor C514 (L-CH) C515 (R-CH)	
	10 kHz		

Adjustment Location: See Fig. A above.

10. Record Level Adjustment

Settings:

SPEED SELECT switch: 19 cm and 9.5 cm (7 1/2 and 3 3/4)
 TAPE SELECT (EQ) switch: SPECIAL
 LINE control: normal setting on page 11

Procedure:

1. Mode: record

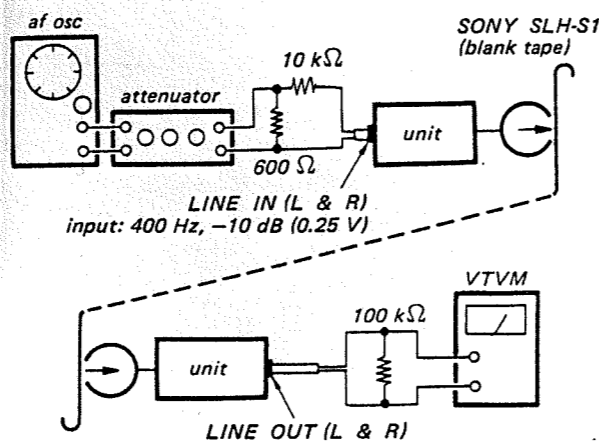

Mode	Tape Speed	Adjust	VTVM Reading
forward record	19 cm/s (7 1/2)	R125 (L-CH) R225 (R-CH)	-5 dB ± 0.5 dB (0.41 ~ 0.45 V)
	9.5 cm/s (3 3/4)		-5 dB ± 2 dB (0.35 ~ 0.55 V)
reverse record	19 cm/s (7 1/2)	R126 (L-CH) R226 (R-CH)	-5 dB ± 0.5 dB (0.41 ~ 0.45 V)
	9.5 cm/s (3 3/4)		-5 dB ± 2 dB (0.35 ~ 0.55 V)

Adjustment Location:

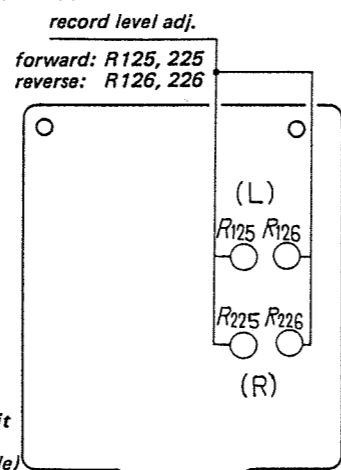

record circuit board (conductor side)

11. Dummy Coil Adjustment

Settings:

TAPE SELECT (EQ) switch: SPECIAL
 LINE control: normal setting on page 11

Procedure:

1. Mode: record

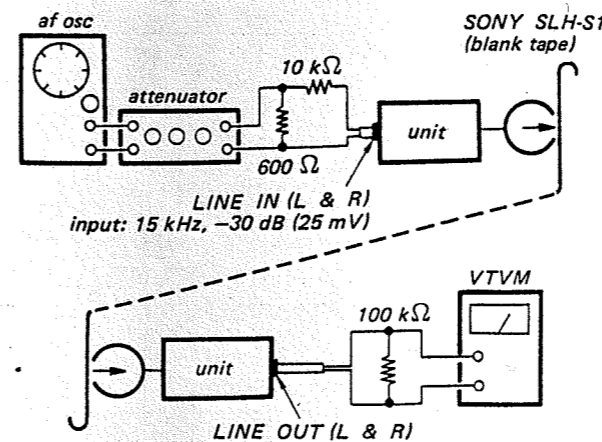

Step	Mode	Adjust	VTVM Reading
1	stereo record	—	Memorize
2	R channel record forward:	L506	R-ch: same as in stereo record mode
	reverse:	L508	
3	L channel record forward:	L505	L-ch: same as in stereo record mode
	reverse:	L507	

Adjustment Location:

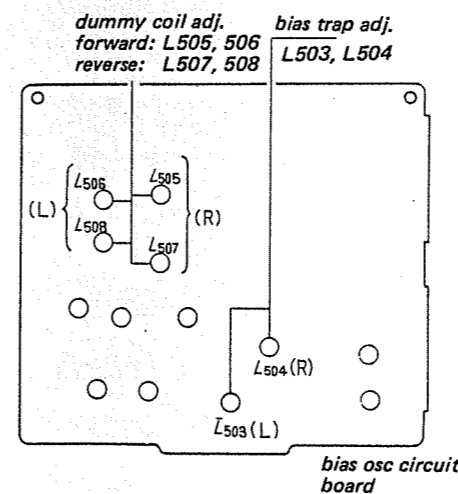

Fig. B. Dummy coil and bias trap adjustment location

12. Bias Trap Adjustment

Settings:

MONITOR switch: SOURCE

Procedure:

1. Mode: forward stereo record

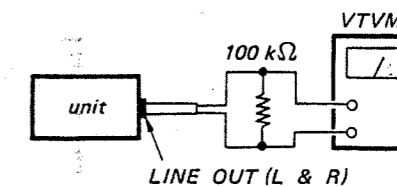

Be sure that the VTVM reading is less than -40 dB (7.7 mV).

2. Test Setup (forward stereo record mode).

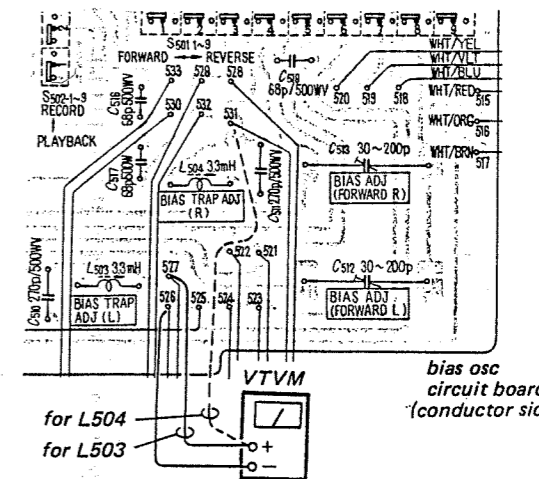

Adjust	VTVM reading
L503	minimum
L504	minimum

Adjustment Location: See Fig. B on the left.

SECTION 5
EXPLODED VIEWS

5-1. EXPLODED VIEW (1)

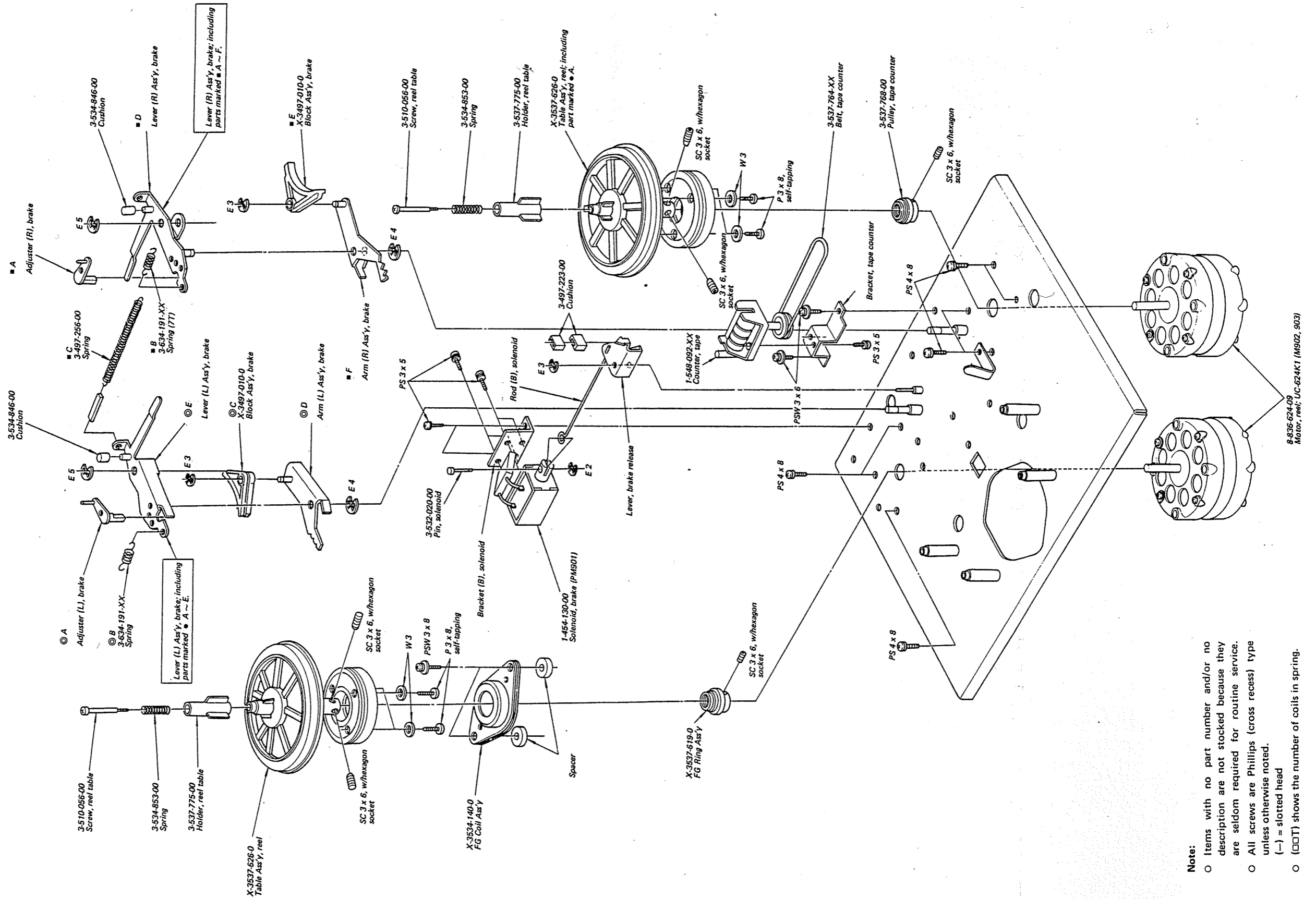

- Note:
- Items with no part number and/or no description are not stocked because they are seldom required for routine service.
 - All screws are Phillips (cross recess) type unless otherwise noted.
 - (—) = slotted head
 - (□□□) shows the number of coils in spring.

5-4. EXPLODED VIEW (4)

Button Ass'y, record; including parts marked A ~ Z.

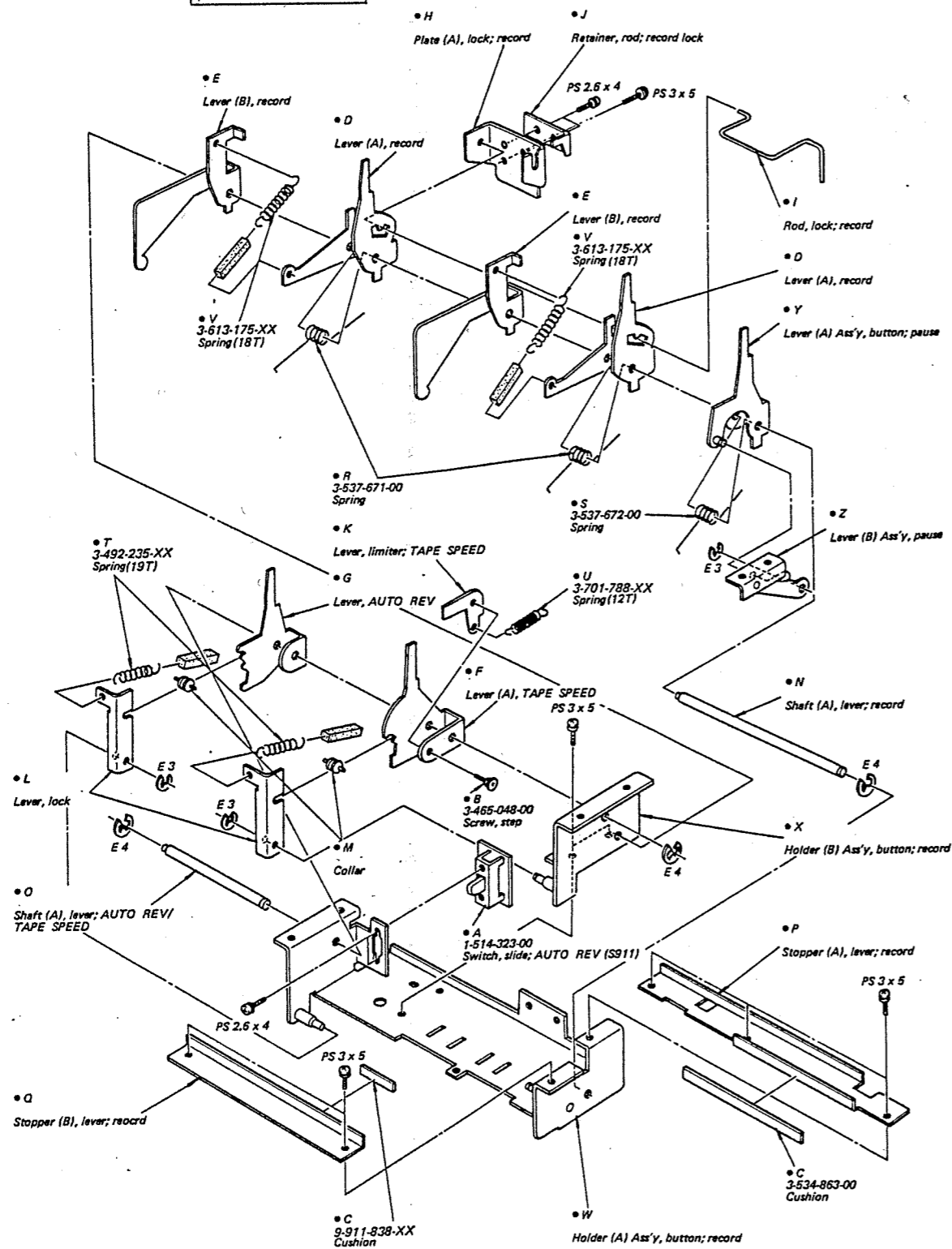

- Note:
- Items with no part number and/or no description are not stocked because they are seldom required for routine service.
 - All screws are Phillips (cross recess) type unless otherwise noted.
 - (-) = slotted head
 - shows the number of coils in spring.

5-3. EXPLODED VIEW (3)

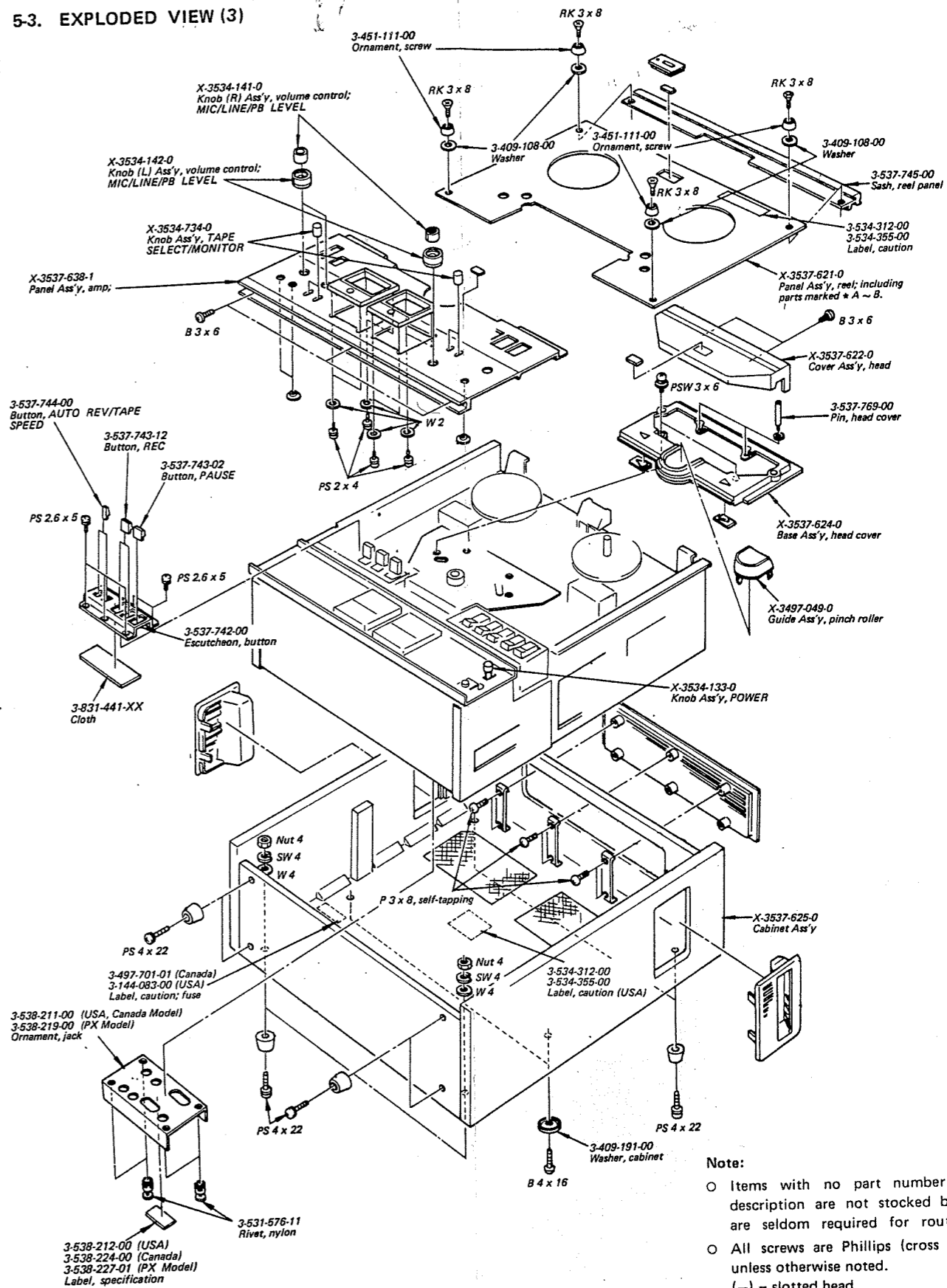

- Note:
- Items with no part number and/or description are not stocked because they are seldom required for routine service.
 - All screws are Phillips (cross recess) type unless otherwise noted.
 - (-) = slotted head

5-5. EXPLODED VIEW (5)

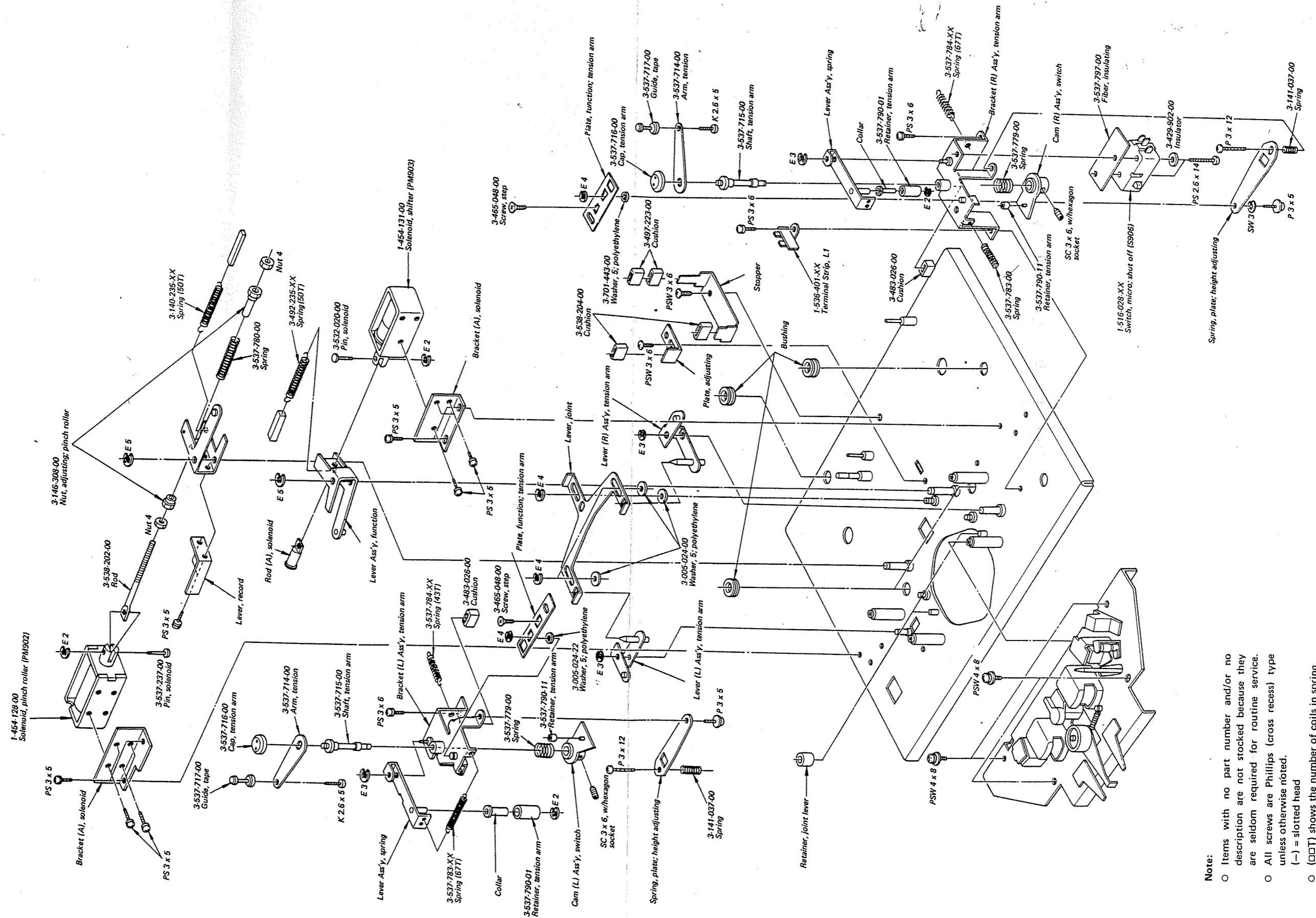

Note:

- Items with no part number and/or no description are not stocked because they are seldom required for routine service.
- All screws are Phillips (cross recess) type unless otherwise noted.
- (-) = slotted head
- (□□□) shows the number of coils in spring.

5.6. EXPLODED VIEW (6)

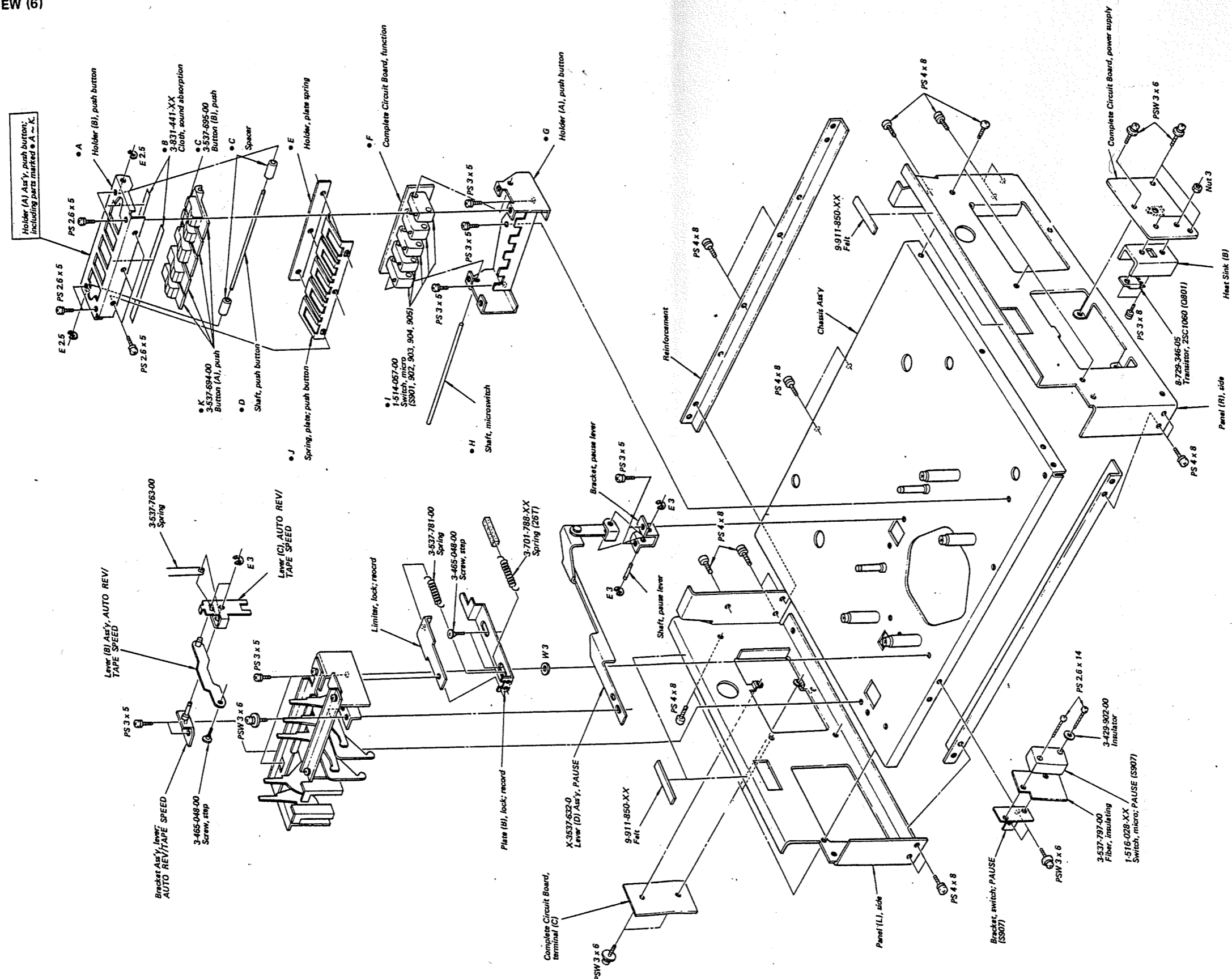

Note:

- Items with no part number and/or no description are not stocked because they are seldom required for routine service.
- All screws are Phillips (cross recess) type unless otherwise noted.
- (□□□) shows the number of coils in spring.

TC-558 TC-558

EXPLODED VIEW (8)

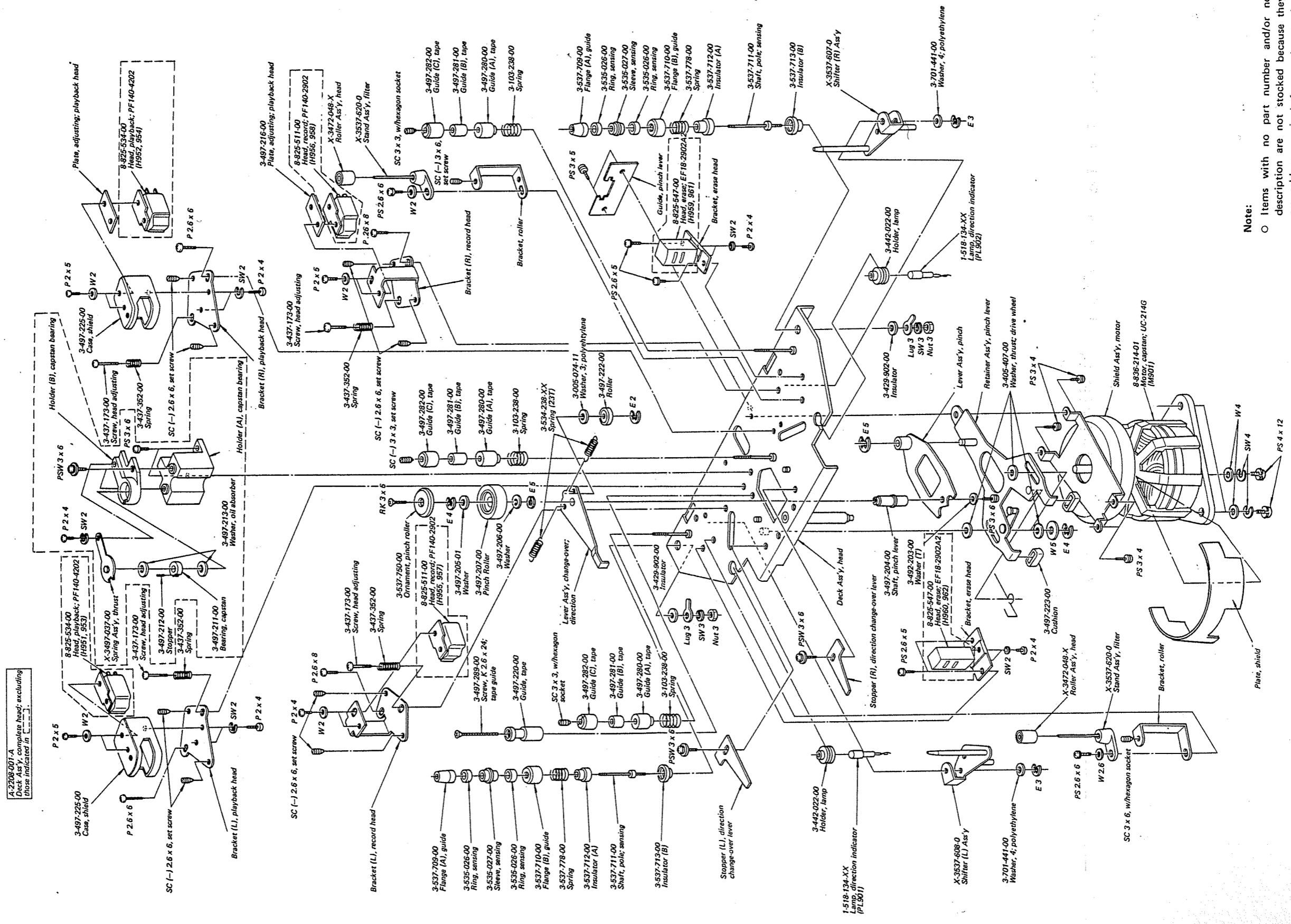

A-2208-001-A
Deck Assy, complete head, excluding those indicated in []

- Note:
- Items with no part number and/or no description are not stocked because they are seldom required for routine service.
 - All screws are Phillips (cross recess) type unless otherwise noted.
 - (—) = slotted head
 - (□□□) shows the number of coils in spring.