

TC-640

2369
General Export and USA Model



Set using ISO screws

SPECIFICATIONS

Power Requirements:	AC 100 V, 110 V, 117 V, 120 V, 125 V, 220 V, 240 V 50/60 Hz, 80 W (for General Export) AC 117 V, 60 Hz, 80 W (for USA)	Flutter and Wow:	0.07 % (WRMS) at 7 1/2 ips (19 cm/s) 0.11 % (WRMS) at 3 3/4 ips (9.5 cm/s)									
Track System:	Four-track stereo and mono	Recording Bias Frequency:	120 kHz									
Reel Size:	7" (18 cm) maximum	Inputs:	Two MICROPHONE inputs Impedance; 600 Ω Maximum sensitivity: 0.19 mV (-72 dB) Two LINE INPUTs Impedance; 100 k Ω Maximum sensitivity; 60 mV (-22 dB)									
Tape Speed:	7 1/2 ips and 3 3/4 ips (19 cm/s and 9.5 cm/s)	Outputs:	Two LINE OUTPUTs Impedance; 100 k Ω Output level; 0.775 V (0 dB) HEADPHONE output Impedance; 8 Ω Output level; 38 mV (-26 dB) with 8 Ω load									
Recording Time:	<table><thead><tr><th>Tape speed</th><th>4-track stereo</th><th>4-track mono</th></tr></thead><tbody><tr><td>7 1/2 ips (19 cm/s)</td><td>1.5 hrs</td><td>3 hrs</td></tr><tr><td>3 3/4 ips (9.5 cm/s)</td><td>3 hrs</td><td>6 hrs</td></tr></tbody></table> (with 1,800 ft. tape)	Tape speed	4-track stereo	4-track mono	7 1/2 ips (19 cm/s)	1.5 hrs	3 hrs	3 3/4 ips (9.5 cm/s)	3 hrs	6 hrs	Semiconductors:	22-transistors and 8-diodes
Tape speed	4-track stereo	4-track mono										
7 1/2 ips (19 cm/s)	1.5 hrs	3 hrs										
3 3/4 ips (9.5 cm/s)	3 hrs	6 hrs										
Frequency Response:	30 ~ 20,000 Hz at 7 1/2 ips (19 cm/s) 30 ~ 15,000 Hz at 3 3/4 ips (9.5 cm/s) (with standard tape) 20 ~ 25,000 Hz at 7 1/2 ips (19 cm/s) 30 ~ 18,000 Hz at 3 3/4 ips (9.5 cm/s) (with SONY SLH tape)	Dimensions:	14 ^{17/32} (W) x 15 ^{9/16} (H) x 9 ^{19/32} (D) (369 x 395 x 243.5 mm)									
Signal-to-Noise Ratio:	52 dB (with standard tape) 55 dB (with SONY SLH tape)	Weight:	33 lb 2 oz (15 kg)									

SONY®

SERVICE MANUAL

2369

TABLE OF CONTENTS

<u>Section</u>	<u>Title</u>	<u>Page</u>	<u>Section</u>	<u>Title</u>	<u>Page</u>
	Specifications	1			
1.	GENERAL DESCRIPTION		6-2-4.	REC MODE Circuit Board	39
1-1.	Block Diagram	3	6-2-5.	SOS & ECHO Circuit Board	39
1-2.	Major Parts Locations	4~5	6-2-6.	Resistor Terminal	40
2.	DISASSEMBLY	6	6-3.	Level Diagram	41
3.	FREQUENCY ADAPTATION	6	7.	SEMICONDUCTOR ELECTRODES	42
4.	MAINTENANCE		8.	ELECTRICAL PARTS LIST	43~46
4-1.	Lubrication	7	9.	EXPLODED VIEWS	
4-2.	Cleaning	7	9-1.	Cabinet – top view –	47~48
4-3.	Demagnetizing	7	9-2.	Amp Chassis – top view (1) –	49~50
5.	ADJUSTMENT PROCEDURES		9-3.	Head Deck –top view (1)	51~52
5-1.	Mechanical Adjustments	8~11	9-4.	Head Deck –top view (2)	53
5-2.	Electrical Adjustments	12~24	9-5.	Printed Circuit Board – top view –	54
6.	DIAGRAMS		9-6.	Chassis –top view –	55~56
6-1.	Schematic Diagram	25~28	9-7.	Chassis –bottom view –	57~58
6-2.	Mounting Diagram		9-8.	Jack Panel	59
6-2-1.	REC BIAS Circuit Board	29~32	9-9.	Packing	60~61
6-2-2.	PB AMP Circuit Board	33~36	10.	HARDWARES	62
6-2-3.	System Control Circuit Board	37~38		Hardware Nomenclature	62

SECTION 1 GENERAL DESCRIPTION

1-1. BLOCK DIAGRAM

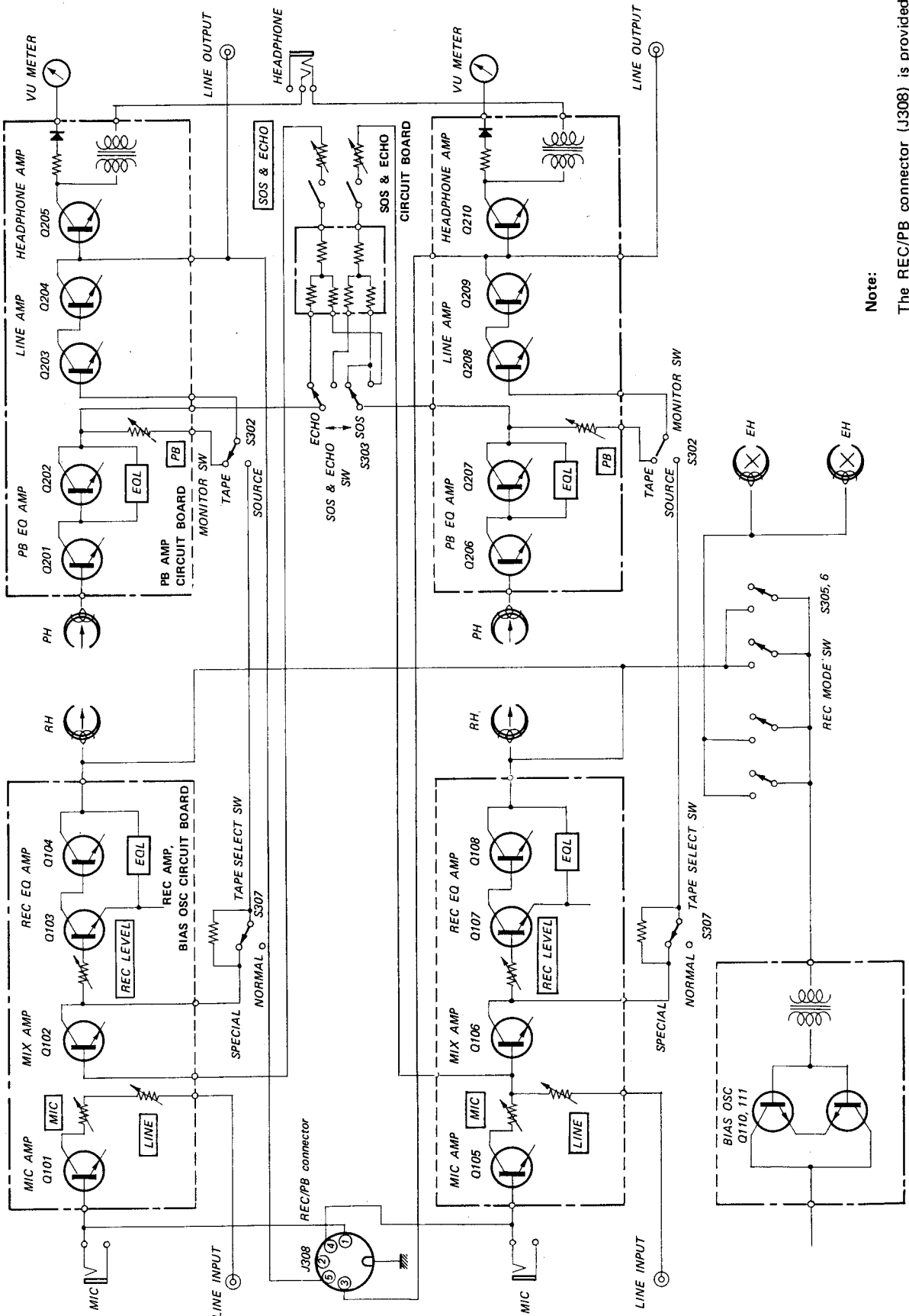

Note:
The REC/PB connector (J308) is provided for General Export Model only.

1-2. MAJOR PARTS LOCATIONS

Cabinet — Front View —

Y-20410-12-6S
counter, tape index

3-144-042-10
panel, reel

3-140-864-01
reel table

3-144-058
cover, head

X-31408-07
roller ass'y, guide

3-144-128
pushbutton

1-514-769 (S305, S306)
switch, lever; REC MODE

1-507-281 (J301, J302)
jack, MICROPHONE

1-507-282 (J303)
jack, binaural: HEADPHONE

X-31440-11
knob C ass'y, VOL (ECHO/SOS)

1-514-324 (S303)
switch, slide; SOS & ECHO

X-31440-09
knob B ass'y, MIC VOL

X-31440-08
cabinet ass'y, wood

3-140-864-01
reel table

1-514-692
switch, lever; MONITOR (S302)

3-144-050-20
knob, lever switch; REC

X-31408-04
pinch roller ass'y

3-144-050-30
knob, lever switch; rewind

3-144-050-40
knob, lever switch; stop

3-144-050-10
knob, lever switch; forward

3-144-050-30
knob, lever switch; fast forward

3-144-079
cover, pushbutton B

1-514-789
switch, slide; TAPE SPEED (S301)

X-31440-09
knob B ass'y, PB VOL

X-31440-09
knob B ass'y, LINE VOL

1-513-347
switch, slide; TAPE SELECT (S307)

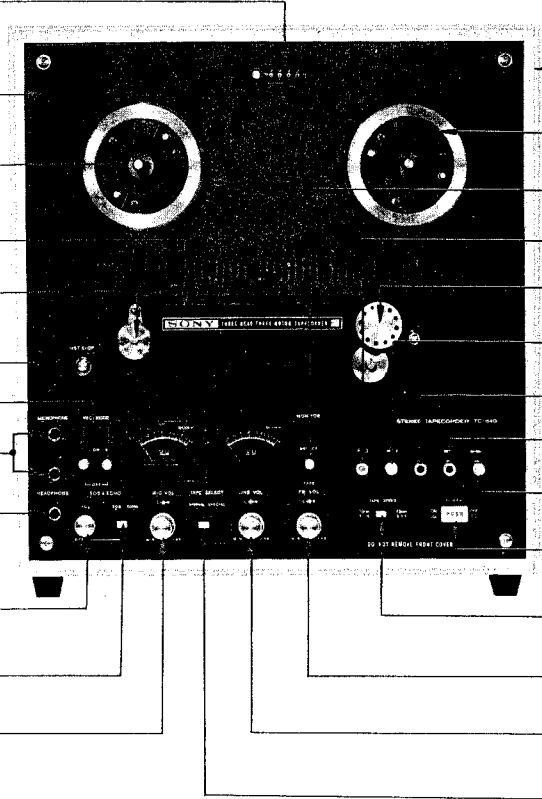

Cabinet — Back View —

3-456-002
grille, ventilation

1-509-341 (CNJ402)
socket, AC OUTLET

1-507-142 (J304, 305)
jack, phono: LINE INPUT

1-509-029 (J308)
connector, REC/PB
(for General Export)

1-507-142 (J306, 307)
jack, phono; LINE OUTPUT

1-532-100
fuse, 2A

1-509-064
socket, voltage
selector (J403)
(for General Export)

1-509-062 (CNJ401)
socket, POWER SUPPLY

X-38012-04
terminal ass'y, GROUND

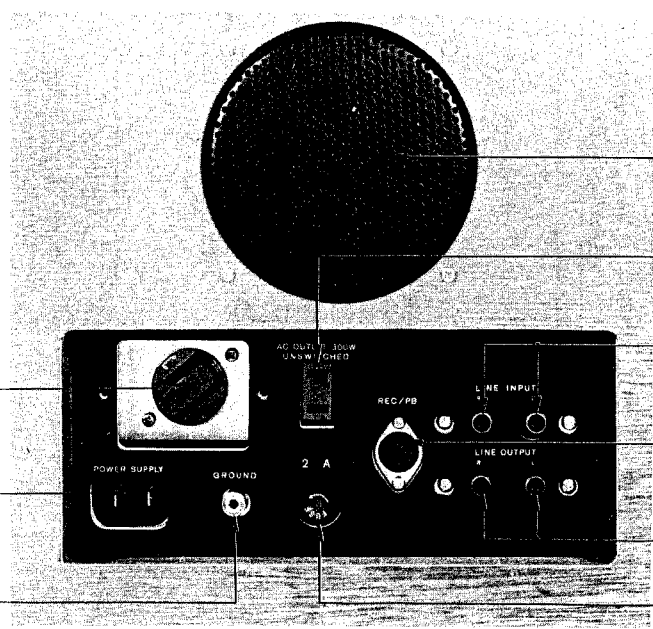

Chassis – Front View –

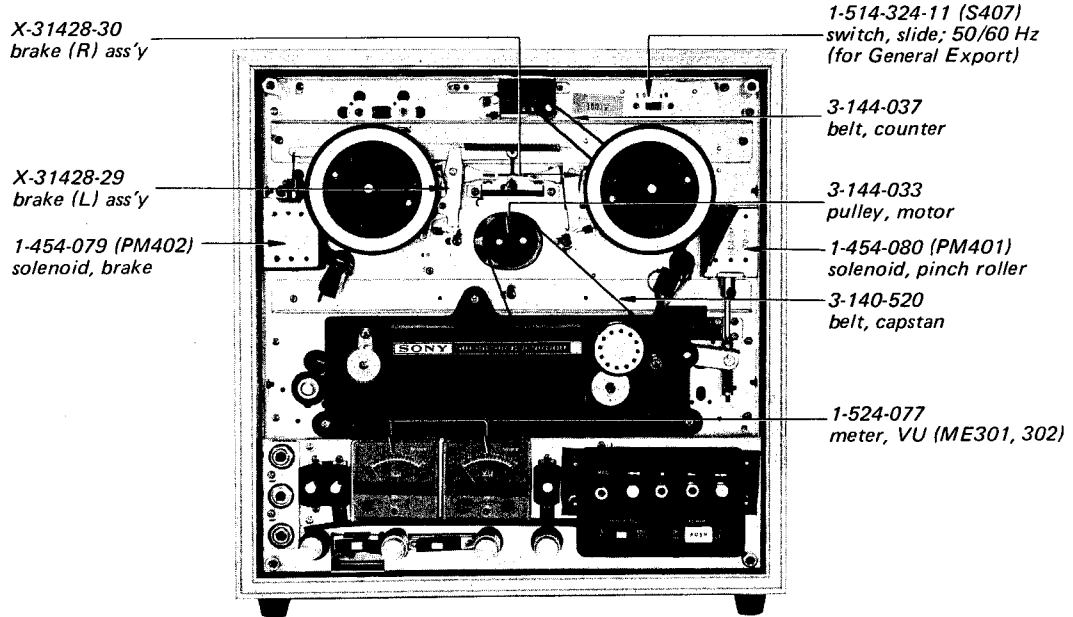

Chassis – Back View –

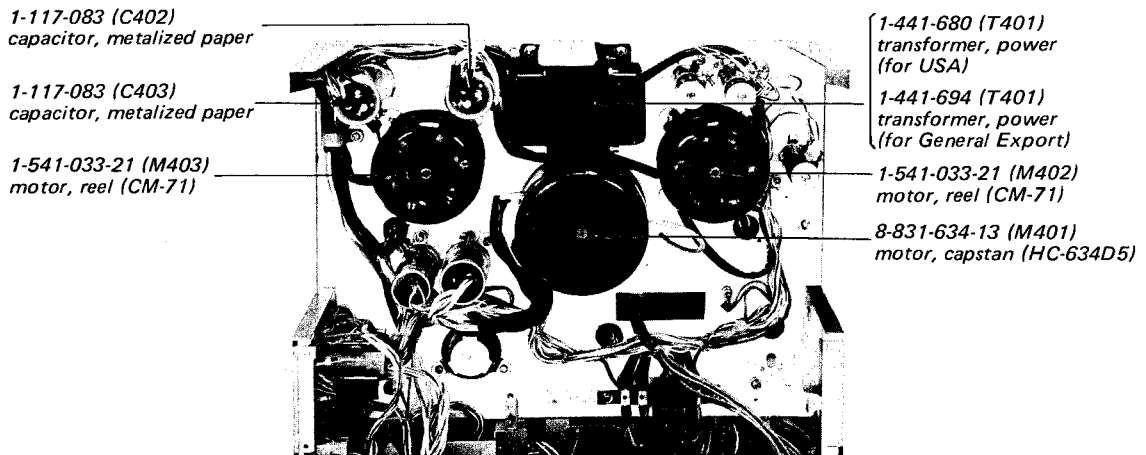

SECTION 2 DISASSEMBLY

Cabinet Removal

Remove the cabinet by removing the seven screws marked with Δ in Fig. 2-1.

Panel Removal

Remove the panel by removing the four screws (\oplus RK 4 x 15) marked with \circ in Fig. 2-1.

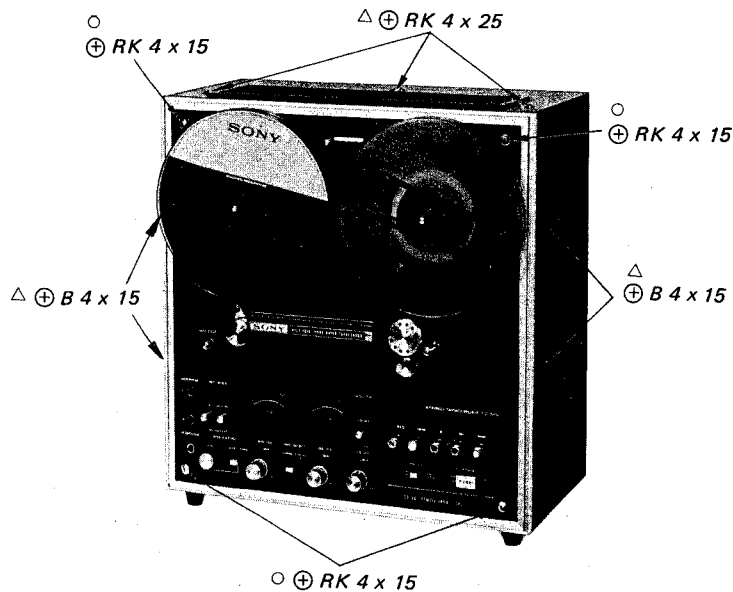

Fig. 2-1.

SECTION 3 FREQUENCY ADAPTATION

1. Remove the front panel by loosening the four screws.
2. Set the frequency selector for the line frequency of your local area.
3. Remove the motor pulley by the two set screws and reinsert the motor pulley upside down, then tighten the screws again.
4. Slightly loosen the four screws which tighten the capstan motor to the chassis. Then, slide the motor as illustrated and tighten the screws again.
5. Replace the rubber belt on the motor pulley so that the belt is threaded horizontally. Try to turn the motor pulley several times to see whether the belt is threaded securely.
6. Replace the front panel.

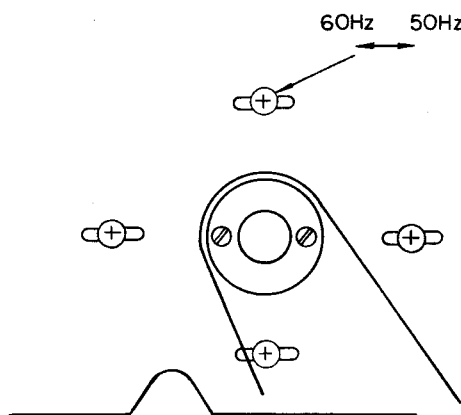

Fig. 3-1. Frequency adaptation

SECTION 4 MAINTENANCE

4-1. LUBRICATION

Use light machine oil and lubricate the pinch roller shaft and capstan drive motor lubricating hole. Avoid excessive lubrication. It will cause slippage of the mechanism. If the oil spills on the pinch roller or the rubber belt, wipe it off immediately with denatured alcohol. To lubricate them, proceed as follows:

- (1) Remove the head cover and the screw securing pinch roller and then lubricate the pinch roller shaft with one drop of light machine oil.
- (2) Remove the reel panel and lubricate the motor lubricating hole with several drops of light machine oil.

Note: Use the oil which is comparatively viscous at the pinch roller shaft.

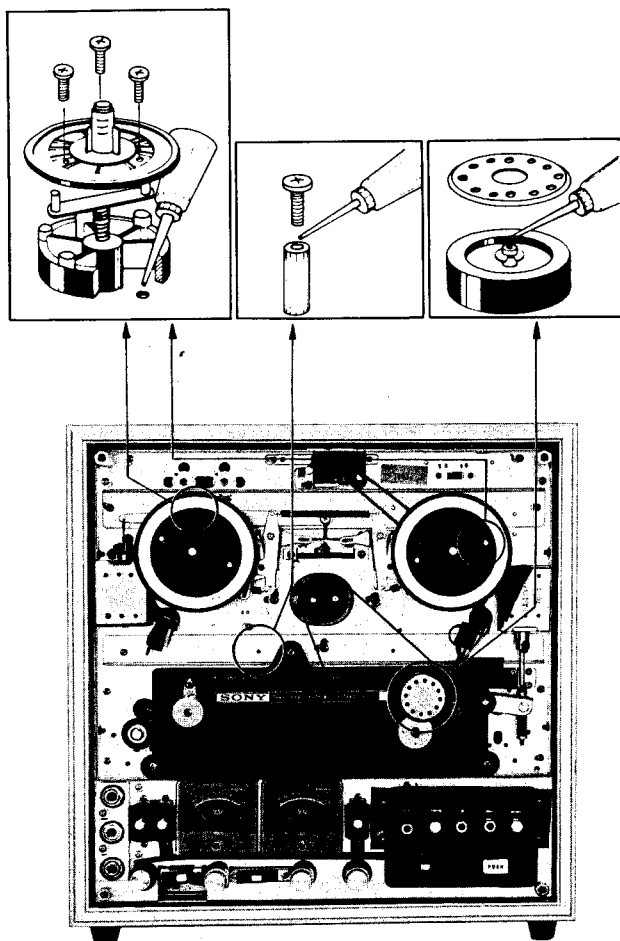

4-2. CLEANING

Dusts and dirt which were brought by tape may stick to the core of the record, playback or erase head, and they may deteriorate the performance of the record and the playback heads. So wipe off the surface of the heads, with a clean and soft cloth dampened with denatured alcohol. To ensure proper operation, the heads should be cleaned at least once during each ten hours of actual operation.

CAUTION

Do not use any other solvent on the head as some will damage the material which binds the head laminations together. Also do not use any metallic device which will scratch the head.

At the same time, clean capstan, rubber belt, pinch roller, tape guide, flutter filter roller and tension arm.

4-3. DEMAGNETIZING

The record and playback heads may occasionally acquire a degree of permanent magnetization, which will result in an increase of noise level, distortion of any recorded signal, and a gradual erasure of high frequency on any recorded tape which passed over them. These heads may be easily demagnetized with a SONY head demagnetizer HE-2 (optional accessory) or equivalent.

To demagnetize the heads, proceed as follows:

Steps:

- (1) Remove the head cover.
- (2) Make sure that power switch on the TC-640 is in the OFF position.
- (3) Connect the demagnetizer to ac power source.
- (4) Bring the tips of the demagnetizer in close proximity to, but not in contact with, the heads so that the tips straddle the gap in the center of the head, run the tips up and down the heads several times, and then slowly withdraw the demagnetizer.

CAUTION

Do not bring magnet close to heads.

SECTION 5 ADJUSTMENT PROCEDURES

5-1. MECHANICAL ADJUSTMENTS

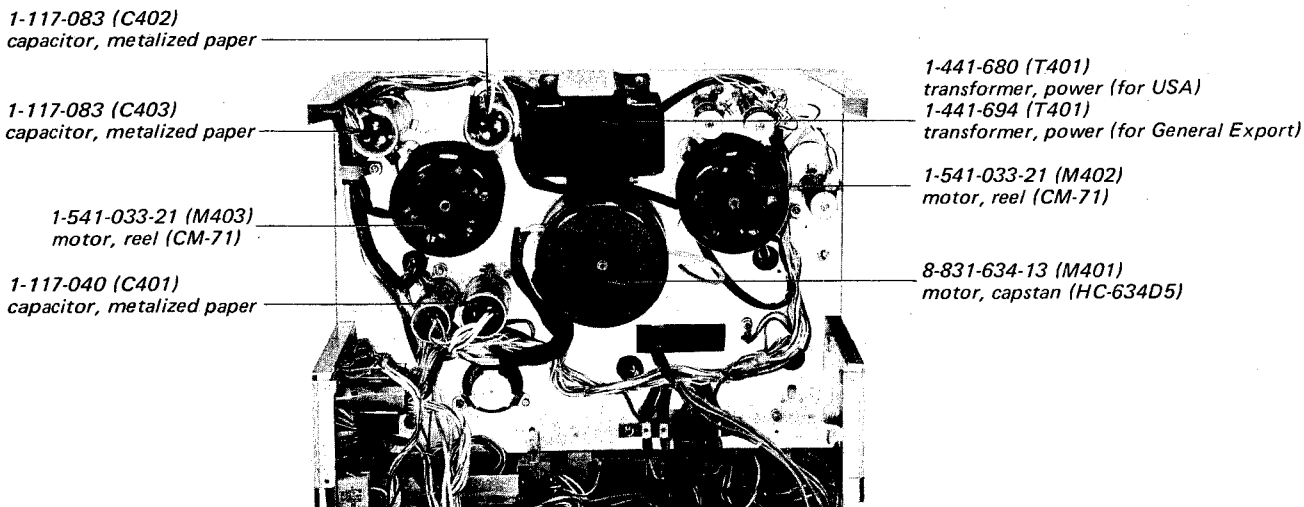

Adjusting parts locations

5-1-1. Automatic Shut-off Switch Adjustment

1. Remove the head deck by taking off the two screws, and put it upside down on a soft cloth.
2. Make sure that the shut-off lever does not touch the head deck when pushing it by the hand. See Fig. 5-1-1.
3. If necessary, adjust the position of the actuator bracket by loosening the screws A.
4. Place the head deck in a normal position. See Fig. 5-1-1.
5. Push the shut-off lever slowly by the hand, and check to see that the microswitch turns on when the lever comes the one-third position of the slot as shown in Fig. 5-1-2.
6. If necessary, adjust the position of the microswitch by loosening the screws (B) and (C).
7. Release the shut-off lever, and make sure that the microswitch turns off when the actuator comes at one-fourth position of the slot (See Fig. 5-1-2).
8. Make sure that the shut-off lever reaches the top of the slot when pushing the lever by the hand.
9. If it is not, readjust the position of the actuator bracket.

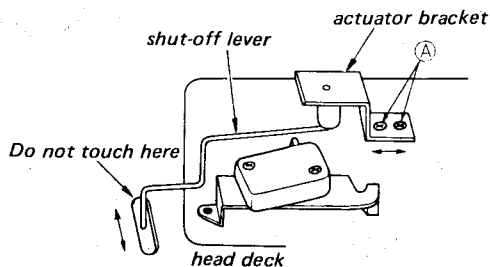

Fig. 5-1-1. Automatic shut-off switch adjustment (1)

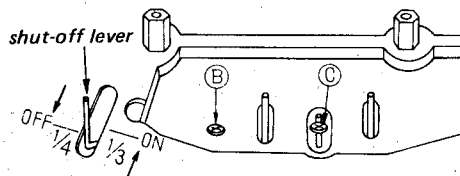

Fig. 5-1-2. Automatic shut-off switch adjustment (2)

5-1-2. Pinch Roller Pressure Adjustment

1. Place the unit in the play mode to energize the pinch roller solenoid, and turn on the automatic shut-off switch.

Note: Hold the shut-off lever so that the shut-off switch is activated (a rubber band or a piece of masking tape will hold the shut-off lever as though tape were threaded on the unit.)

2. Adjust the adjusting nut (A) for 1 mm (3/64") clearance between the link shaft and the adjusting nut (A). See Fig. 5-1-3.
3. Attach the spring scale (5 kg) to the pinch roller shaft with a piece of string. See Fig. 5-1-4. Pull the scale horizontally in the direction shown by the arrow. The capstan shaft, pinch roller and the spring scale should be in a line. Check the reading just when the pinch roller separates from the capstan.
4. Adjust the adjusting nut (B) for 2.2 ± 0.2 kg. (4.4 to 5.3 lb)
5. Repeat steps 2 to 4 several times.
6. After adjustment, lock the adjusting nut (B) by the lock nut (B).
7. Adjust the adjusting nut (A) for the clearance of 0.1 to 0.2 mm between the lock nut (A) and the link shaft.
8. Lock the adjusting nut (A) by the lock nut (A).
9. Check for the correct value again.

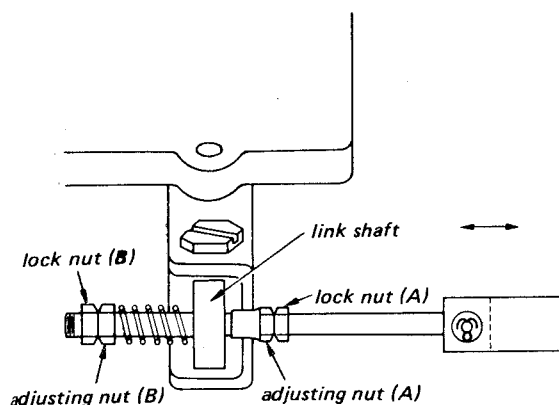

Fig. 5-1-3. Pinch roller pressure adjustment (1)

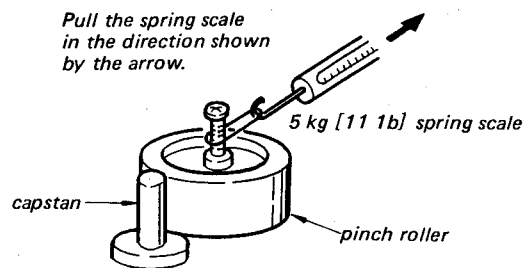

Fig. 5-1-4. Pinch roller pressure adjustment (2)

5-1-3. Microswitch Position Adjustment

1. Check to see that the microswitch (for pinch roller solenoid) is turned on when the pinch roller touches the capstan. See Fig. 5-1-5.
2. If it is not, adjust the position of the microswitch by loosening the screws A.

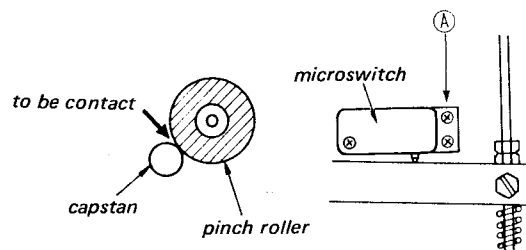

Fig. 5-1-5. Microswitch position adjustment

5-1-4. Reel Motor Torque Adjustment

Take-up Motor Torque Adjustment

1. Place the reel with string wound several turns clockwise on the hub (44 mm dia) onto the take-up reel table. Tie the string to the spring scale.
2. Hold the shut-off lever so that the shut-off switch is activated (a rubber band or a piece of masking tape will hold the shut-off lever as though tape were threaded on the unit).
3. Place the unit in the play mode. Pull the spring scale and then allow to take up the string on the reel while approaching the scale to the reel at the same speed of tape running. Adjust RV401 for 330 to 350 g-cm (4.58 to 4.86 oz. inch) on the spring scale. See Fig. 5-1-6.

Note: Read the scale while moving it.

Back Tension Torque Adjustment

1. Place the empty hub with string wound several turns counterclockwise on the hub (44 mm dia) onto the supply reel table. Tie the string to the spring scale.
2. Hold the shut-off lever so that the shut-off switch is activated (a rubber band or a piece of masking tape will hold the shut-off lever as though tape were threaded on the unit.)
3. Place the unit in the play mode. Pull the spring scale at the same speed of tape running. Adjust RV402 for 240 to 260 g-cm (3.32 to 3.60 oz. inch) on the spring scale. See Fig. 5-1-6.

Note: Read the scale while pulling it.

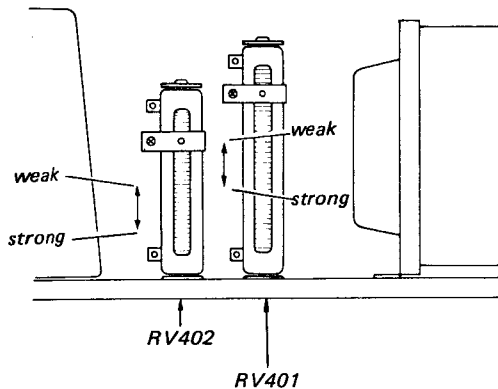

Fig. 5-1-6. Reel motor torque adjustment

5-1-5. Brake Torque Adjustment

This adjustment should be performed for both supply and take-up sides.

Note: The instructions in [] are applied to the supply brake torque adjustment.

1. Place the unit in the STOP mode.
2. Bend the portion Δ of the brake lever with a pair of pliers so that the clearance between the brake lever and the limiter is approx. 2 mm (5/64").
3. Place an empty reel with string wound several turns counterclockwise [clockwise] on the hub onto the reel table.
Tie the spring to a spring scale.

4. Pull the spring scale horizontally at a constant speed, making sure that the string does not touch either flange of the reel. The reel table will rotate counterclockwise [clockwise]. Take a reading only when the reel table is in steady motion.
5. Make sure that the brake torque is 350 to 450 g.cm (4.86 to 6.25 oz. inch).
6. Place an empty reel with string wound several turns clockwise [counterclockwise] on the hub onto the reel table.
Tie the spring to a spring scale.
7. Pull the scale horizontally at constant speed, making sure that the string does not touch either flange of the reel. The reel table will rotate clockwise [counterclockwise]. Take a reading only when the reel table is in steady motion.
8. Make sure that the brake torque is 1,000 to 1,300 g-cm (13.9 to 18.1 oz. inch).
9. If it is not, change the hooking position of the spring for the specified brake torque.
10. Check to see that the center pole of the solenoid should be pulled out from the solenoid by approx. 3 mm (1/8") in STOP mode as shown in Fig. 5-1-9.
If it is not, adjust the position of the brake arm bracket A marked with \star .
11. Make sure that the capstan belt does not rub against the portion marked with \blacktriangle of the brake lever in the play mode.

Specification:

Brake Torque of Supply Reel
 in clockwise turning . . 350 - 450 g-cm
 (4.86 - 6.25 oz. inch)
 in counterclockwise turning
 . . 1,000 - 1,300 g-cm
 (13.9 - 18.1 oz. inch)

Brake Torque of Take-up Reel
 in clockwise turning . . 1,000 - 1,300 g-cm
 (13.9 - 18.1 oz. inch)
 in counterclockwise turning
 . . 350 - 450 g-cm
 (4.86 - 6.25 oz. inch)

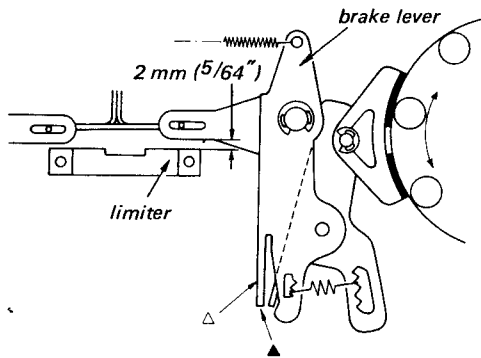

Fig. 5-1-7. Brake torque adjustment (1)

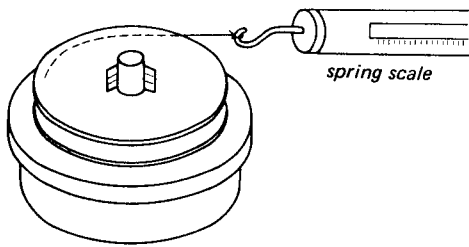

Fig. 5-1-8. Brake torque adjustment (2)

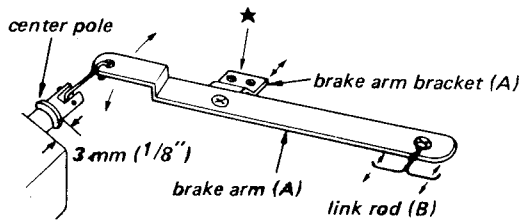

Fig. 5-1-9. Brake torque adjustment (3)

5-1-6. Reel Table Height Adjustment

1. Place the unit in the play mode.
2. See Fig. 5-1-11. Adjust the height of the take-up reel table by loosening the set screws with an allen wrench so that the tape is on the middle portion between the upper and lower flanges of the reel.
3. Check for the supply reel table height in the rewind mode.

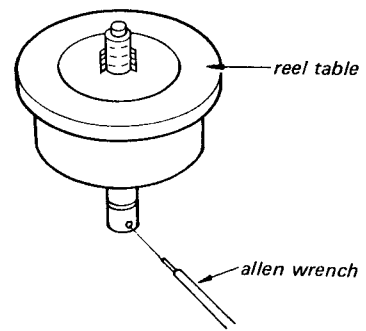

Fig. 5-1-10. Reel table height adjustment (1)

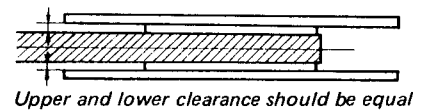

Fig. 5-1-11. Reel table height adjustment (2)

5-2. ELECTRICAL ADJUSTMENTS

Before making adjustments, carefully read the followings.

1. Clean the record, playback and erase heads with a soft cloth dampened with denatured alcohol.
2. Demagnetize the record and playback heads with a head demagnetizer (SONY HE-2 or equivalent).
3. Set the switches to the following positions, unless otherwise indicated.

MONITOR switch TAPE
 TAPE SELECT switch NORMAL
 ECHO & SOS VOL switch OFF
 REC MODE switch OFF
 TAPE SPEED switch 19 cm/s

4. Input Connection

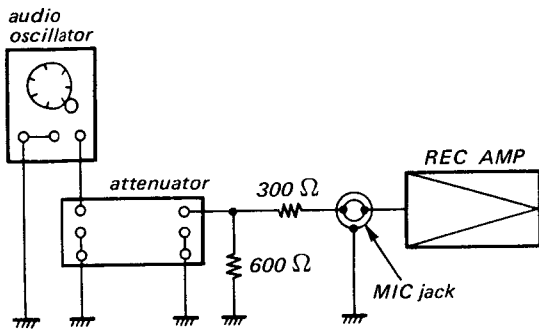

Fig. 5-2-1.

5. Output Connection

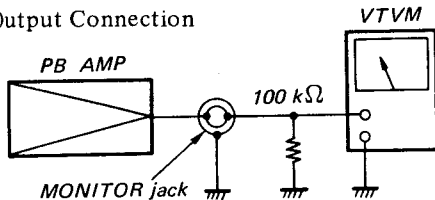

Fig. 5-2-2.

6. Input and output levels are specified as follows, unless otherwise indicated.

Normal input level

	MICROPHONE	LINE INPUT
Input signal level	-60 dB (0.775 mV)	-10 dB (0.245 V)
Signal source impedance	600 Ω	100 kΩ

Normal output level

	LINE OUT	HEADPHONE
Output level	0 dB (0.775 V)	-28 dB (31 mV)
Load resistor	100 kΩ	8 Ω

7. Set the VOL controls to the following position, unless otherwise indicated.

(1) MIC VOL (In using the MIC jack)

Set the LINE VOL controls extremely counterclockwise and the MONITOR switch to SOURCE. Deliver a 1 kHz signal (-60 dB) to the MIC jack and adjust the MIC VOL controls so that the LINE OUT level is 0 dB (0.775 V).

(2) LINE VOL (In using the LINE INPUT jack)

Set the MIC VOL controls extremely counterclockwise and the MONITOR switch to SOURCE. Deliver a 1 kHz signal (-10 dB) to the LINE INPUT jack and adjust the LINE VOL controls so that the LINE OUT level is 0 dB (0.775 V).

(3) PB VOL

Set the MONITOR switch to TAPE. Play the 1st tone (400 Hz, 0 dB) of SONY alignment tape and adjust the PB VOL controls so that the LINE OUT level is 0 dB (0.775 V).

8. The adjustment should be performed for both L-CH and R-CH.

9. The test equipments required for the adjustment are as follows:

- Audio oscillator
- Attenuator
- Fixed resistors 100 kΩ, 2.2 kΩ and 2.2 kΩ
- oscilloscope
- VTVM
- Standard tape (blank)
- SONY SLH tape (blank)
- Non-metallic screwdriver
- SONY alignment tapes J-19-F2, J-9-F1, J-19-A2
- distortion meter
- 1 kHz bandpass filter

10. A blank test tape should be a new tape or a well-demagnetized tape.

11. The following SONY alignment tapes are required for the adjustments. They contain the following information in the sequence indicated.

tone tape	1st	2nd	3rd	4th	5th	6th	7th
J-19-F1	5 kHz -10 dB	400 Hz 0 dB	400 Hz -10 dB	5 kHz -10 dB	3 kHz -10 dB	160 Hz -10 dB	80 Hz -10 dB
J-19-F2	400 Hz 0 dB	400 Hz -10 dB	10 kHz -10 dB	12.5 kHz -10 dB	7 kHz -10 dB	80 Hz -10 dB	40 Hz -10 dB
J-19-A2	12.5 kHz (-10 dB)						

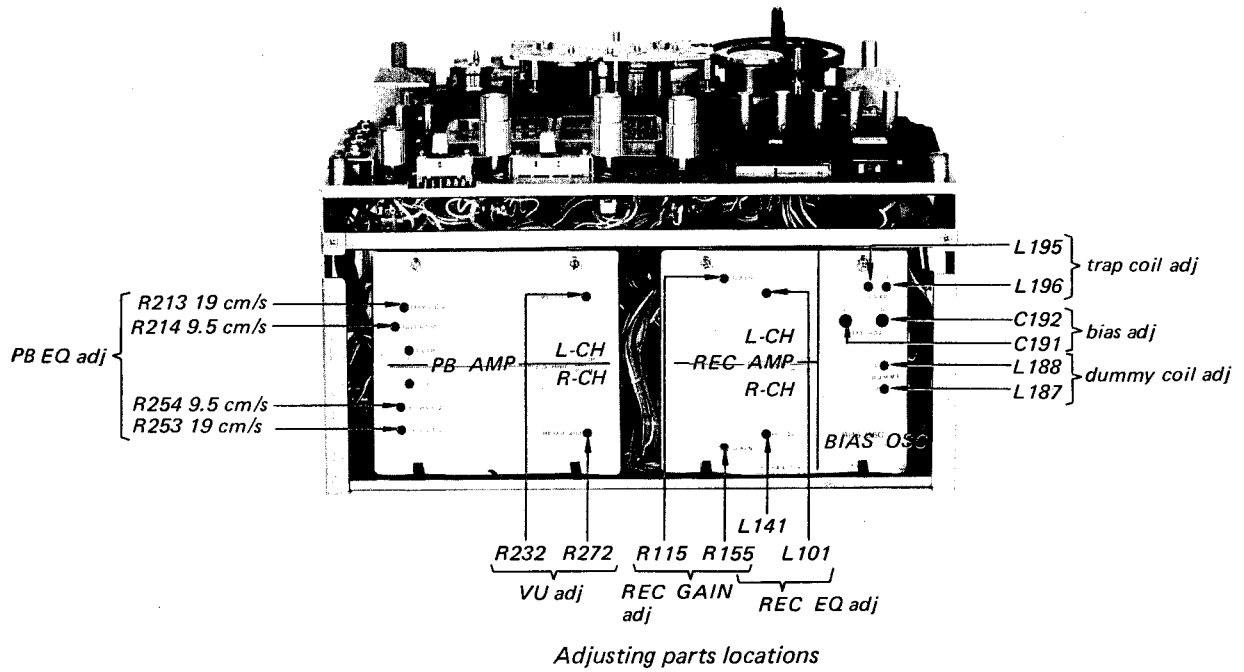

Items	Remarks	Procedure
<p>1. DC Power Voltage Check</p>	<p>Test Setup;</p> <p>Specification: 21.5 ± 1 V dc DC 50 V range</p>	<ol style="list-style-type: none"> 1. Turn on the power switch. 2. Check for the reading on the dc voltmeter connected between the terminals 12 (+) and 7 (-) on the system control circuit board.
<p>2. Automatic Shut-off Switch Operation Check</p>		<ol style="list-style-type: none"> 1. Turn on the power switch. 2. Depress the play lever with the shut-off lever pushed by the hand. 3. Make sure that the unit is set in the play mode. 4. Release the shut-off lever. The play lever should be released and the set should be changed to the stop mode.
<p>3. Function Lever Check</p>		<ol style="list-style-type: none"> 1. Turn off the power switch. 2. Thread the tape along the tape path. 3. Push the play lever (or both play and record levers) 4. Turn on the power switch with ac 90 V power source. 5. Make sure that the tape starts to run in the play (or record) mode.

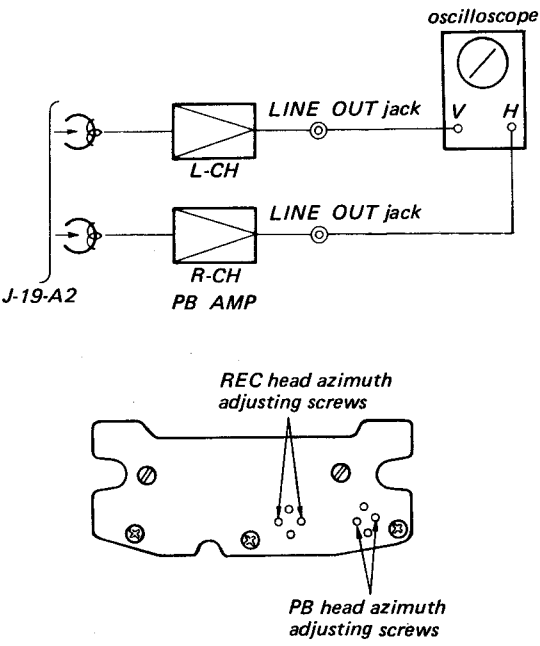
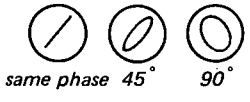
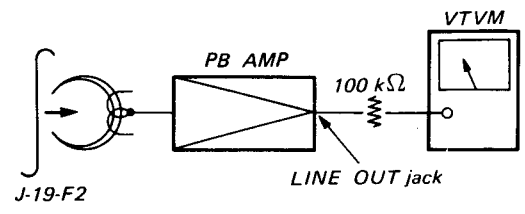
Items	Remarks	Procedure
<p>4. PB Head Azimuth Adjustment</p>	<p>Test Setup:</p>  <p>* Screw position: Angle where the maximum output level is obtained</p> <p>* Phase difference between channels: Same phase at 400 Hz within 90° at 10 kHz</p>	<ol style="list-style-type: none"> 1. Play back the SONY alignment tape (J-19-A2). 2. Adjust the adjusting screws for maximum playback output at both channels. 3. Make sure that the same phase is obtained at 2nd tone (400 Hz) of the alignment tape (J-19-F2). 4. When touching the tape near the playback head with a finger or a nonmetallic equipment, make sure it does not cause a higher output level.  <p><i>Lissajous figure on the oscilloscope</i></p>
<p>5. VU Meter Calibration</p>	<p>Test Setup:</p> 	<ol style="list-style-type: none"> 1. Place the unit in the vertical position. 2. Make sure that the pointer of the VU meter indicates -20 on the scale with no input signal in the play mode. 3. Play back the first tone (400 Hz) of the SONY alignment tape (J-19-F2). 4. Adjust the PB VOL control to obtain 0 dB (0.775 V) on the VTVM. 5. Adjust R232 (R272) to obtain 0 VU on the level meter. <p>Notes:</p> <ol style="list-style-type: none"> 1. Gain margin of PB VOL control should be 6 to 8 dB. 2. Do not turn the PB VOL control after the above step 4.

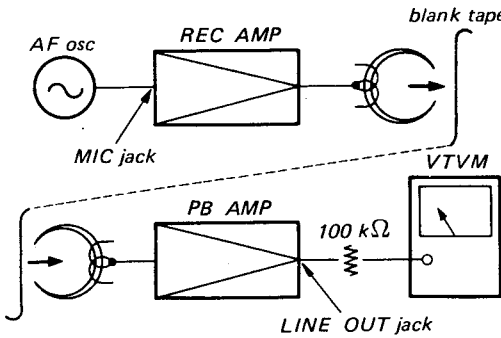
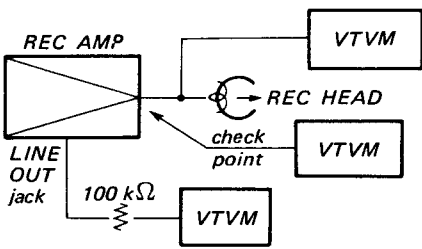
Items	Remarks	Procedure
<p>6. Azimuth Adjustments (Record Head)</p>	<p>Test Setup:</p> 	<ol style="list-style-type: none"> 1. Thread a blank tape along the tape path. 2. Deliver a 10 kHz signal of -80 dB ($77.5 \mu\text{V}$) to the MICROPHONE jack. 3. Set the MONITOR switch to SOURCE. 4. Record the signal on the blank tape. 5. Adjust the azimuth adjusting screw for maximum reading on the VTVM. 6. Make sure that the playback output is not increased when touching the tape near the record head with a finger or a nonmetallic rod.
<p>7. Trap Coil Adjustment & Bias Current Leakage Measurement</p>	<p>Test Setup:</p>  <p>Specification:</p> <p>* Bias current leakage: Less than -40 dB</p>	<ol style="list-style-type: none"> 1. Place the unit in the record mode. 2. Adjust C191 (C192) so that the VTVM connected across the record head reads approximately 10 V. 3. Set the MIC VOL and LINE VOL controls extremely counterclockwise. 4. Adjust L195 and L196 for the minimum reading on the VTVM connected to the check points. 5. Measure the bias current leakage in the playback output without the tape threaded. <p>Notes:</p> <ol style="list-style-type: none"> 1. A shielded wire should not be used for the lead of VTVM. 2. Use a nonmetallic screwdriver. 3. The bias current leakage measurement is required for both stereo and monaural record modes. 4. Check points: <ul style="list-style-type: none"> L-Ch : terminal (2) R-Ch : terminal (42) on the rec bias circuit board

Items	Remarks	Procedure
<p>8. Record Bias Adjustment</p>	<p>Test Setup:</p>	<ol style="list-style-type: none"> 1. Thread a blank tape along the tape path. 2. Set the MIC VOL and LINE VOL controls to the specified position on page 12. 3. Turn the trimmer capacitors C91 and C92 clockwise to the full and turn them counterclockwise by three or four turns. 4. Deliver a 1 kHz signal of -60 dB (0.775 mV) to the MICROPHONE jack. 5. Record the signal on the blank tape. 6. Turn C91 (C92) clockwise slowly until the VTVM reads a maximum. 7. Turn C91 (C92) moreover until the VTVM reads 0.5 dB below the maximum reading. 8. After adjustment, apply lock paint to the capacitors.
<p>9. Record Level Adjustment</p>	<p>Test Setup:</p>	<ol style="list-style-type: none"> 1. Thread a blank tape along the tape path. 2. Set the MONITOR switch to SOURCE. 3. Deliver a 1 kHz signal of -60 dB (0.775 mV) to the MICROPHONE jack. 4. Adjust the MIC VOL control to obtain 0 dB (0.775 V) on the VTVM. <p>Note:</p> <p>When changing the TAPE SELECT switch to SPECIAL, make sure that the output decreases approximately 1 to 1.5 dB.</p> <ol style="list-style-type: none"> 5. Change the MONITOR switch to TAPE. 6. Record the signal on the blank tape. 7. Adjust R115 (R155) to obtain 0 dB (0.775 V) on the VTVM.

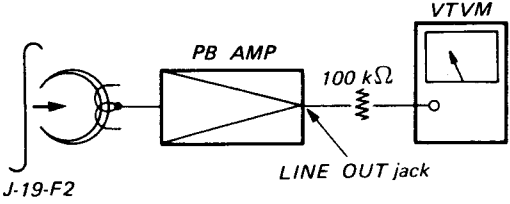
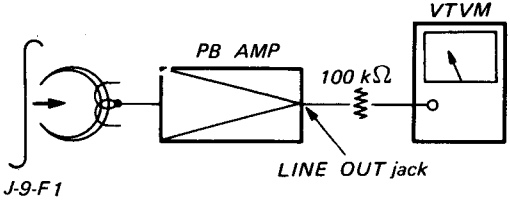
Items	Remarks	Procedure												
<p>10. Playback Frequency Response Measurement 19 cm/s (7-1/2 ips)</p>	<p>Test Setup:</p>  <p>Specification:</p> <table border="1" data-bbox="422 719 767 1122"> <thead> <tr> <th>tape tone</th> <th>level deviation against 2nd tone</th> </tr> </thead> <tbody> <tr> <td>3 rd (10 kHz)</td> <td>0 ± 1.5 dB</td> </tr> <tr> <td>4 th (12.5 kHz)</td> <td>0. ± 1.5 dB</td> </tr> <tr> <td>5th (7 kHz)</td> <td>0 ± 1.5 dB</td> </tr> <tr> <td>6th (80 Hz)</td> <td>+ 1.0 ± 2.0 dB</td> </tr> <tr> <td>7th (40 Hz)</td> <td>+ 1.0 ± 3.0 dB</td> </tr> </tbody> </table>	tape tone	level deviation against 2nd tone	3 rd (10 kHz)	0 ± 1.5 dB	4 th (12.5 kHz)	0. ± 1.5 dB	5th (7 kHz)	0 ± 1.5 dB	6th (80 Hz)	+ 1.0 ± 2.0 dB	7th (40 Hz)	+ 1.0 ± 3.0 dB	<ol style="list-style-type: none"> Adjust R213 (R253) to obtain the same output between the 2nd (400 Hz) and 3rd (10 kHz) tones of the alignment tape (J-19-F2). Play the alignment tape (J-19-F2) from the 2nd tone to the 7th tone. Measure the deviation of each frequency against the 2nd tone. Make sure that the satisfied result is obtained.
tape tone	level deviation against 2nd tone													
3 rd (10 kHz)	0 ± 1.5 dB													
4 th (12.5 kHz)	0. ± 1.5 dB													
5th (7 kHz)	0 ± 1.5 dB													
6th (80 Hz)	+ 1.0 ± 2.0 dB													
7th (40 Hz)	+ 1.0 ± 3.0 dB													
<p>11. Playback Frequency Response Measurement 9.5 cm/s (3-3/4 ips)</p>	<p>Test Setup:</p>  <p>Specification:</p> <table border="1" data-bbox="427 1563 735 1966"> <thead> <tr> <th>tape tone</th> <th>level deviation against 3rd tone</th> </tr> </thead> <tbody> <tr> <td>4th (5 kHz)</td> <td>0 ± 1.5 dB</td> </tr> <tr> <td>5th (3 kHz)</td> <td>0 ± 1.5 dB</td> </tr> <tr> <td>6th (160 Hz)</td> <td>0 ± 2 dB</td> </tr> <tr> <td>7th (80 Hz)</td> <td>0 ± 3 dB</td> </tr> </tbody> </table>	tape tone	level deviation against 3rd tone	4th (5 kHz)	0 ± 1.5 dB	5th (3 kHz)	0 ± 1.5 dB	6th (160 Hz)	0 ± 2 dB	7th (80 Hz)	0 ± 3 dB	<ol style="list-style-type: none"> Adjust R214 (R254) to obtain the same output between the 3rd (400 Hz) and 4th (5 kHz) tones of the alignment tape (J-9-F1). Play the alignment tape (J-9-F1) from the 3rd tone to the 7th tone. Measure the deviation of each frequency against the 3rd tone. Make sure that the satisfied result is obtained. 		
tape tone	level deviation against 3rd tone													
4th (5 kHz)	0 ± 1.5 dB													
5th (3 kHz)	0 ± 1.5 dB													
6th (160 Hz)	0 ± 2 dB													
7th (80 Hz)	0 ± 3 dB													

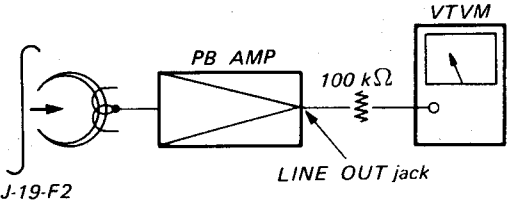
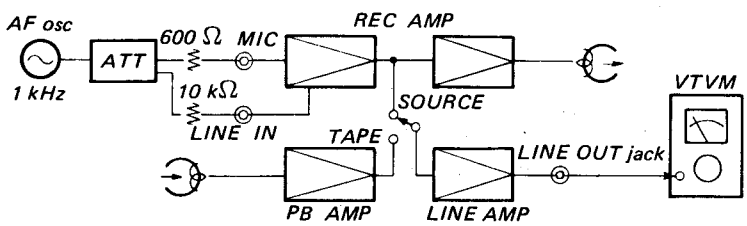
Items	Remarks	Procedure
<p>12. Playback Signal-to-Noise Ratio</p>	<p>Test Setup:</p>  <p>Specification:</p> <p>7-1/2 ips more than 50 dB (19 cm/s)</p> <p>3-3/4 ips more than 48 dB (9.5 cm/s)</p>	<ol style="list-style-type: none"> 1. Set the TAPE SPEED switch to 19 cm/s (7-1/2 ips). 2. Play the 1st tone (400 Hz) of the SONY alignment tape (J-19-F2). 3. Adjust the PB VOL control so that the VTVM will indicate 0 dB (0.775 V). 4. Place the unit in the play mode without any tape. <p>Note:</p> <p>Hold the shut-off lever so that the shut-off switch is activated (a rubber band or a piece of masking tape will hold the shut-off lever as though tape were threaded on the unit).</p> <ol style="list-style-type: none"> 5. Note the VTVM reading. 6. Make sure that the difference between the above steps 2 and 4 is more than 50 dB. 7. Set the TAPE SPEED switch to 9.5 cm/s (3-3/4 ips). 8. Note the VTVM reading. 9. Make sure that the difference between the above steps 2 and 8 is more than 50 dB.
<p>13. Input Level Variation Check</p>	<p>Test Setup:</p>  <p>Specification:</p> <p>* MIC VOL Less than 0.5 dB</p> <p>* LINE VOL Less than 0.5 dB</p>	<p><i>Level variation by MIC VOL Control</i></p> <ol style="list-style-type: none"> 1. Set the LINE VOL control to the normal position. 2. Deliver a 1 kHz signal of -10 dB (0.245 V) the LINE INPUT jack. 3. Check for the level variation on the VTVM by turning the MIC VOL control from MIN to MAX. <p><i>Level variation by LINE VOL Control</i></p> <ol style="list-style-type: none"> 1. Set the MIC VOL control to the normal position. 2. Deliver a 1 kHz signal of -60 dB (0.775 mV) to the MIC jack. 3. Check for the level variation on the VTVM by turning the LINE VOL control from MIN to MAX.

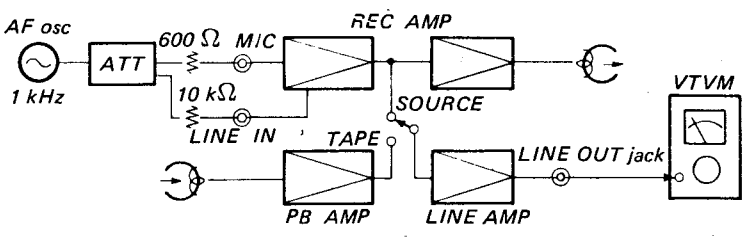
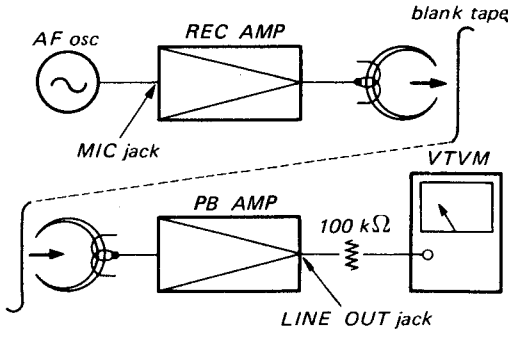
Items	Remarks	Procedure
<p>14. Minimum Input Level Check</p>	<p>Test Setup:</p>  <p>Specification:</p> <ul style="list-style-type: none"> * MIC jack Less than -72 dB (0.2 mV) * LINE INPUT jack Less than -22 dB (61 mV) 	<ol style="list-style-type: none"> 1. Set the MONITOR switch to SOURCE. 2. Deliver a 1 kHz signal of -72 dB (0.2 mV) to the MICROPHONE jack. 3. Set the LINE VOL control fully counterclockwise. 4. Make sure that the line output is more than 0 dB on the VTVM when turning the MIC VOL control fully clockwise. 5. Deliver a 1 kHz signal of -22 dB (61 mV) to the LINE INPUT jack. 6. Set the MIC VOL control fully counterclockwise. 7. Make sure that the line output is more than 0 dB on the VTVM when turning the LINE VOL control fully clockwise.
<p>15. Input and Output Check of REC/PB Connector (This check is applied for General Export model only)</p>	<p>Test Setup:</p>  <p>Specification:</p> <p>0 ± 2 dB (0.62 - 0.97 V)</p>	<ol style="list-style-type: none"> 1. Set the MIC VOL and LINE VOL controls to the normal position. 2. Connect the audio oscillator to pin 1 (4) and 2 of the REC/PB connector. 3. Deliver a 1 kHz signal of -34 dB (15.5 mV) from the audio oscillator. 4. Place the unit in the record mode. 5. Make sure that the VTVM reads 0 dB (0.775 V). 6. Disconnect the VTVM from the LINE OUT jack and connect it to pin 3 (5) and 2 of the REC/PB connector. 7. Play back the recorded tape. 8. Make sure that the VTVM reads 0 ± 2 dB (0.62 - 0.97 V).

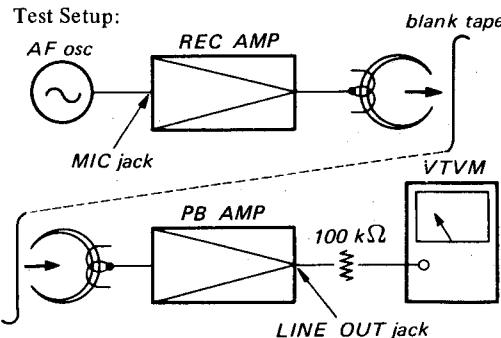
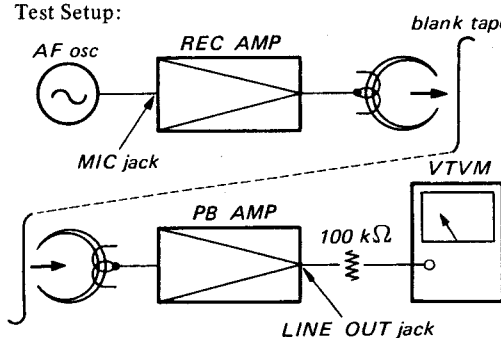
Items	Remarks	Procedure																								
<p>16. Overall Frequency Response Adjustment (NORMAL)</p>	<p>Test Setup:</p>  <p>Specification:</p> <table border="1" data-bbox="343 728 750 1153"> <thead> <tr> <th>speed tone \</th> <th>7-1/2 ips (19 cm/s)</th> <th>3-3/4 ips (9.5 cm/s)</th> </tr> </thead> <tbody> <tr> <td>50 Hz</td> <td>± 3 dB</td> <td>± 3 dB</td> </tr> <tr> <td>100 Hz</td> <td>± 3 dB</td> <td>± 3 dB</td> </tr> <tr> <td>1 kHz</td> <td></td> <td></td> </tr> <tr> <td>5 kHz</td> <td>± 3 dB</td> <td>± 3 dB</td> </tr> <tr> <td>10 kHz</td> <td>± 3 dB</td> <td>± 3 dB</td> </tr> <tr> <td>15 kHz</td> <td>± 3 dB</td> <td>-</td> </tr> <tr> <td>18 kHz</td> <td>+ 3 dB -15dB</td> <td>-</td> </tr> </tbody> </table>	speed tone \	7-1/2 ips (19 cm/s)	3-3/4 ips (9.5 cm/s)	50 Hz	± 3 dB	± 3 dB	100 Hz	± 3 dB	± 3 dB	1 kHz			5 kHz	± 3 dB	± 3 dB	10 kHz	± 3 dB	± 3 dB	15 kHz	± 3 dB	-	18 kHz	+ 3 dB -15dB	-	<ol style="list-style-type: none"> 1. Thread a blank tape along the tape path. 2. Set the TAPE SELECT switch to NORMAL. 3. Set the MIC VOL and LINE VOL controls to the specified position on page 12. 4. Record the following frequency signals of -80 dB (77.5 μV): 50 Hz, 100 Hz, 1 kHz, 5 kHz, 10 kHz, 15 kHz and 18 kHz through the MICROPHONE jack. 5. Make sure that each deviation in the level for a 1 kHz signal is within the specification. 6. If it is not, perform the record bias adjustment.
speed tone \	7-1/2 ips (19 cm/s)	3-3/4 ips (9.5 cm/s)																								
50 Hz	± 3 dB	± 3 dB																								
100 Hz	± 3 dB	± 3 dB																								
1 kHz																										
5 kHz	± 3 dB	± 3 dB																								
10 kHz	± 3 dB	± 3 dB																								
15 kHz	± 3 dB	-																								
18 kHz	+ 3 dB -15dB	-																								
<p>17. Overall Frequency Response Adjustment (SPECIAL)</p>	<p>Test Setup:</p>  <p>Specification:</p> <table border="1" data-bbox="343 1590 750 1993"> <thead> <tr> <th>speed tone \</th> <th>7-1/2 ips (19 cm/s)</th> <th>3-3/4 ips (9.5 cm/s)</th> </tr> </thead> <tbody> <tr> <td>50 Hz</td> <td>± 3 dB</td> <td>± 3 dB</td> </tr> <tr> <td>100 Hz</td> <td>± 3 dB</td> <td>± 3 dB</td> </tr> <tr> <td>1 kHz</td> <td></td> <td></td> </tr> <tr> <td>5 kHz</td> <td>± 3 dB</td> <td>± 3 dB</td> </tr> <tr> <td>10 kHz</td> <td>± 3 dB</td> <td>± 3 dB</td> </tr> <tr> <td>15 kHz</td> <td>± 3 dB</td> <td>± 3 dB</td> </tr> <tr> <td>18 kHz</td> <td>± 3 dB</td> <td>-</td> </tr> </tbody> </table>	speed tone \	7-1/2 ips (19 cm/s)	3-3/4 ips (9.5 cm/s)	50 Hz	± 3 dB	± 3 dB	100 Hz	± 3 dB	± 3 dB	1 kHz			5 kHz	± 3 dB	± 3 dB	10 kHz	± 3 dB	± 3 dB	15 kHz	± 3 dB	± 3 dB	18 kHz	± 3 dB	-	<ol style="list-style-type: none"> 1. Thread a blank tape (SONY SLH tape) along the tape path. 2. Set the TAPE SELECT switch to SPECIAL. 3. Set the MIC VOL and LINE VOL controls to the specified position on page 12. 4. Record the following frequency signals of -80 dB (77.5 μV): 50 Hz, 100 Hz, 1 kHz, 5 kHz, 10 kHz, 15 kHz and 18 kHz through the MICROPHONE jack. 5. Make sure that each deviation in the level for a 1 kHz signal is within the specification. 6. If it is not, perform the record bias adjustment.
speed tone \	7-1/2 ips (19 cm/s)	3-3/4 ips (9.5 cm/s)																								
50 Hz	± 3 dB	± 3 dB																								
100 Hz	± 3 dB	± 3 dB																								
1 kHz																										
5 kHz	± 3 dB	± 3 dB																								
10 kHz	± 3 dB	± 3 dB																								
15 kHz	± 3 dB	± 3 dB																								
18 kHz	± 3 dB	-																								

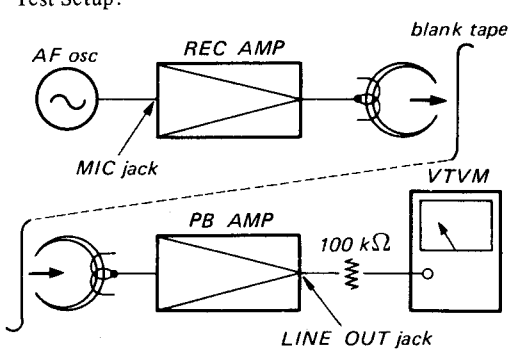
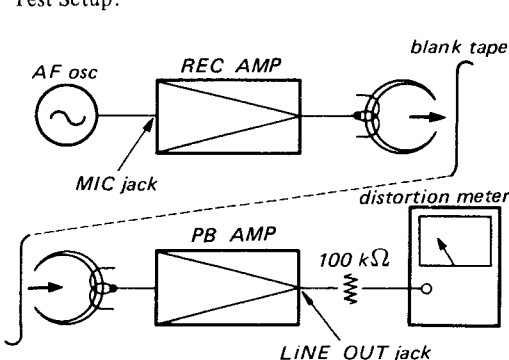
Items	Remarks	Procedure								
<p>18. Overall Signal-to-Noise Ratio Measurement</p>	<p>Test Setup:</p>  <p>The diagram shows a signal path starting from an AF oscillator connected to a MIC jack, which feeds into the REC AMP. The output of the REC AMP is connected to a blank tape. The tape is then connected to the PB AMP, which is also connected to a 100 kΩ resistor and a VTVM. The output of the PB AMP is connected to a LINE OUT jack.</p> <p>NORMAL (standard tape):</p> <table border="0"> <tr> <td>7-1/2 ips (19 cm/s)</td> <td>3-3/4 ips (9.5 cm/s)</td> </tr> <tr> <td>46 dB</td> <td>44 dB</td> </tr> </table> <p>SPECIAL (SONY SLH tape):</p> <table border="0"> <tr> <td>7-1/2 ips (19 cm/s)</td> <td>3-3/4 ips (9.5 cm/s)</td> </tr> <tr> <td>48 dB</td> <td>46 dB</td> </tr> </table>	7-1/2 ips (19 cm/s)	3-3/4 ips (9.5 cm/s)	46 dB	44 dB	7-1/2 ips (19 cm/s)	3-3/4 ips (9.5 cm/s)	48 dB	46 dB	<ol style="list-style-type: none"> 1. Thread a blank tape along the tape path. 2. Deliver a 1 kHz signal of -60 dB (0.775 mV) to the MIC jack. 3. Place the unit in the record mode. 4. Record the signal for a minute. 5. Disconnect the audio oscillator, and terminate the MIC jack with a dummy resistor of 600 Ω. 6. Keep the unit in the record mode with no input signal. 7. Playback the signal recorded portion and no signal recorded portion. 8. Make sure that the difference between the two recorded portions of the tape is more than the specification. <p>Note: When using an SLH tape, set the TAPE SELECT SWITCH to SPECIAL.</p>
7-1/2 ips (19 cm/s)	3-3/4 ips (9.5 cm/s)									
46 dB	44 dB									
7-1/2 ips (19 cm/s)	3-3/4 ips (9.5 cm/s)									
48 dB	46 dB									
<p>19. Overall Distortion Check</p>	<p>Test Setup:</p>  <p>The diagram shows a signal path starting from an AF oscillator connected to a MIC jack, which feeds into the REC AMP. The output of the REC AMP is connected to a blank tape. The tape is then connected to the PB AMP, which is also connected to a 100 kΩ resistor and a distortion meter. The output of the PB AMP is connected to a LINE OUT jack.</p> <p>Specification:</p> <table border="0"> <tr> <td>7-1/2 ips:</td> <td>Less than 1.5 %</td> </tr> <tr> <td>3-3/4 ips:</td> <td>Less than 2 %</td> </tr> </table>	7-1/2 ips:	Less than 1.5 %	3-3/4 ips:	Less than 2 %	<ol style="list-style-type: none"> 1. Thread a blank tape along the tape path. 2. Deliver a 1 kHz signal of -60 dB (0.775 mV) to the MIC jack. 3. Place the unit in the normal record mode. 4. Check the reading on the distortion meter. 				
7-1/2 ips:	Less than 1.5 %									
3-3/4 ips:	Less than 2 %									

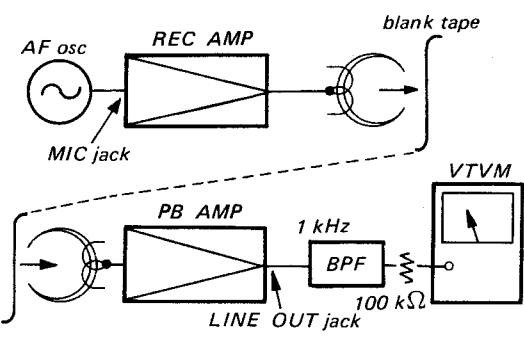
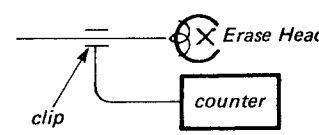
Items	Remarks	Procedure
<p>20. Erase Ratio Measurement</p>	<p>Test Setup:</p>  <p>Specification: more than 65 dB (with SONY SLH tape)</p>	<ol style="list-style-type: none"> 1. Thread a blank tape (SONY SLH tape) along the tape path. 2. Set the TAPE SELECT switch to SPECIAL. 3. Set the MIC VOL and LINE VOL controls to the specified position on page 12. 4. Deliver a 1 kHz signal of -50 dB (2.45 mV) to the MIC jack. 5. Place the unit in the stereo-record mode. 6. Rewind a half of recorded tape. 7. Disconnect the audio oscillator. 8. Terminate the MIC jack with a 600 Ω resistor. 9. Erase the tape in the record mode with no input signal. 10. Rewind again to the beginning of the recorded portion. 11. Play back the tape. 12. Make sure that the difference between the two portions is more than 65 dB on the VTVM.
<p>21. Erase Head Dummy Coil Adjustment</p>	<p>Test Setup:</p> 	<ol style="list-style-type: none"> 1. Unsolder the erase head lead wires. 2. Connect the frequency counter across the lead wires. 3. Place the unit in the stereo-record mode. 4. Make sure that the counter indicates 120 kHz ± 10%. 5. Place the L-CH (R-CH) only in the record mode. 6. Adjust L187 (L188) to obtain the same reading as obtained in the step 4.

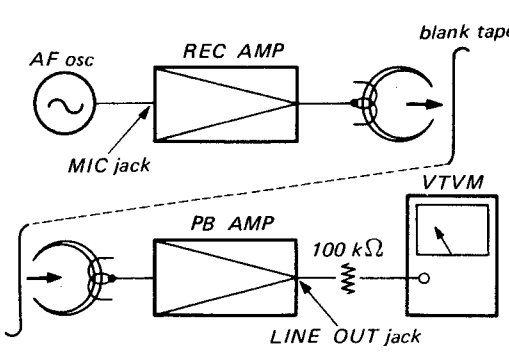
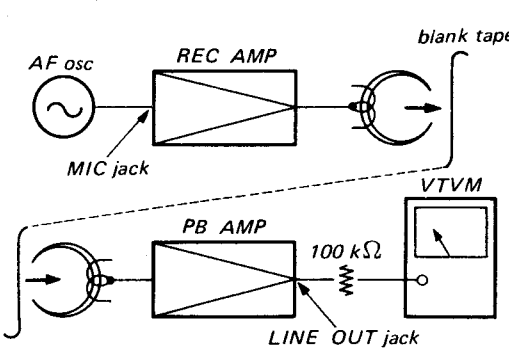
	Remarks	Procedure
<p>22. Crosstalk Measurement (between channels)</p>	<p>Test Setup:</p>  <p>Specification:</p> <p>More than 55 dB (with SONY SLH tape)</p>	<ol style="list-style-type: none"> 1. Thread a blank tape (SONY SLH tape) along the tape path. 2. Set the MIC VOL and LINE VOL controls to the specified position on page 12. 3. Deliver a 1 kHz signal of -50 dB (2.45 mV) to the L-CH (R-CH) MIC jack only. 4. Make sure that the level difference between both channels is more than 55 dB. <p>Note:</p> <p>Use the tape completely erased.</p>
<p>23. Crosstalk Measurement (between tracks)</p>	<p>Test Setup:</p>  <p>Specification:</p> <p>More than 55 dB (with SONY SLH tape)</p>	<ol style="list-style-type: none"> 1. Thread a blank tape (SONY SLH tape) along the tape path. 2. Set the TAPE SELECT switch to SPECIAL. 3. Set the MIC VOL and LINE VOL controls to the specified position on page 12. 4. Deliver a 1 kHz signal of -50 dB (2.45 mV) to the MIC jack. 5. Place the unit in the stereo-record mode. 6. Note the VTVM reading. 7. Reverse the tape reels. 8. Play back the opposite tracks of the recorded tape. 9. Note the VTVM reading. 10. Make sure that the level difference between step 6 and 9 is more than 55 dB.

Items	Remarks	Procedure
24. SOS Check		<ol style="list-style-type: none"> 1. Thread a blank tape along the tape path. 2. Set the MONITOR switch to TAPE. 3. Set the PB VOL controls to the specified position on page 12. 4. Deliver a 1 kHz signal of -60 dB (0.775 mV) to the L-CH (R-CH) MIC jack only. 5. Rewind the tape to the beginning. 6. Set the SOS & ECHO switch to SOS. 7. Place the R-CH (L-CH) only in the record mode. 8. Check to see that R-CH (L-CH) output level becomes the same as L-CH (R-CH) output level by adjusting the SOS & ECHO VOL control.
25. ECHO Check		<ol style="list-style-type: none"> 1. Thread a blank tape along the tape path. 2. Set the SOS & ECHO switch to ECHO. 3. Deliver a 1 kHz signal of -60 dB (0.775 mV) to the MIC jack. 4. Place the unit in the record mode. 5. Check to see that echo level increases as the SOS & ECHO VOL control is turned clockwise. 6. Check to see that oscillation does not occur when turning the PB VOL control fully clockwise. <p>Note:</p> <p>The adjustment is required for both channels.</p>

SECTION 6
DIAGRAMS

6-1. SCHEMATIC DIAGRAM
(for General Export)

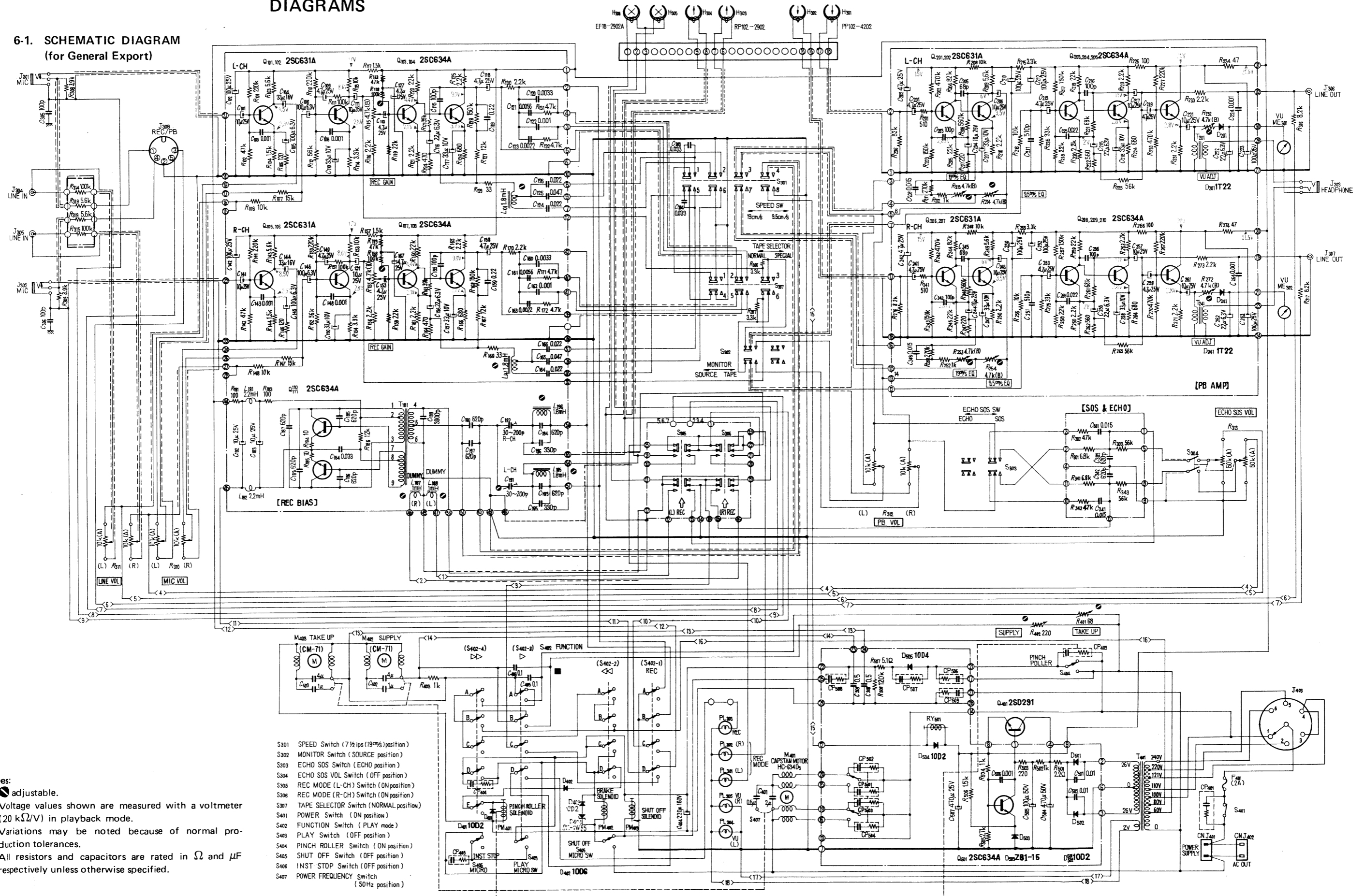

- Notes:
1. adjustable.
 2. Voltage values shown are measured with a voltmeter (20 kΩ/V) in playback mode. Variations may be noted because of normal production tolerances.
 3. All resistors and capacitors are rated in Ω and μF respectively unless otherwise specified.

- S301 SPEED Switch (7 1/2 ips (19796) position)
 S302 MONITOR Switch (SOURCE position)
 S303 ECHO SOS Switch (ECHO position)
 S304 ECHO SOS VOL Switch (OFF position)
 S305 REC MODE (L-CH) Switch (ON position)
 S306 REC MODE (R-CH) Switch (ON position)
 S307 TAPE SELECTOR Switch (NORMAL position)
 S401 POWER Switch (ON position)
 S402 FUNCTION Switch (PLAY mode)
 S403 PLAY Switch (OFF position)
 S404 PINCH ROLLER Switch (ON position)
 S405 SHUT OFF Switch (OFF position)
 S406 INST. STOP Switch (OFF position)
 S407 POWER FREQUENCY Switch (50Hz position)

TC-640 TC-640

SCHEMATIC DIAGRAM (for USA)

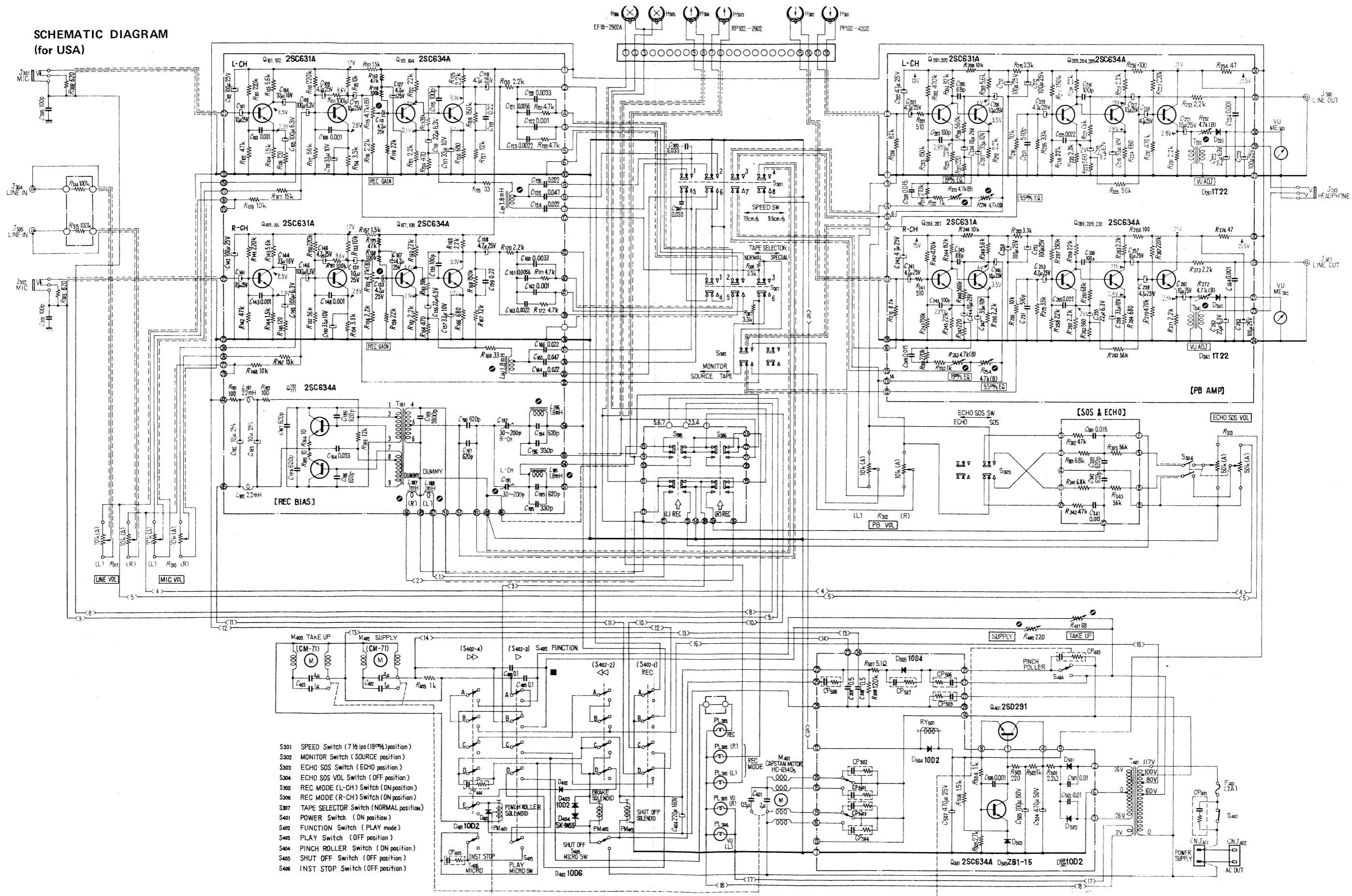

- S301 SPEED Switch (7 1/2 ips (19%) position)
- S302 MONITOR Switch (SOURCE position)
- S303 ECHO SOS Switch (ECHO position)
- S304 ECHO SOS VOL Switch (OFF position)
- S305 REC MODE (L-CH) Switch (ON position)
- S306 REC MODE (R-CH) Switch (ON position)
- S307 TAPE SELECTOR Switch (NORMAL position)
- S401 POWER Switch (ON position)
- S402 FUNCTION Switch (PLAY mode)
- S403 PLAY Switch (OFF position)
- S404 PINCH ROLLER Switch (ON position)
- S405 SHUT OFF Switch (OFF position)
- S406 INST STOP Switch (OFF position)

TC-640 TC-640

6-2. MOUNTING DIAGRAM

6-2-1. REC BIAS Circuit Board

— Conductor Side —

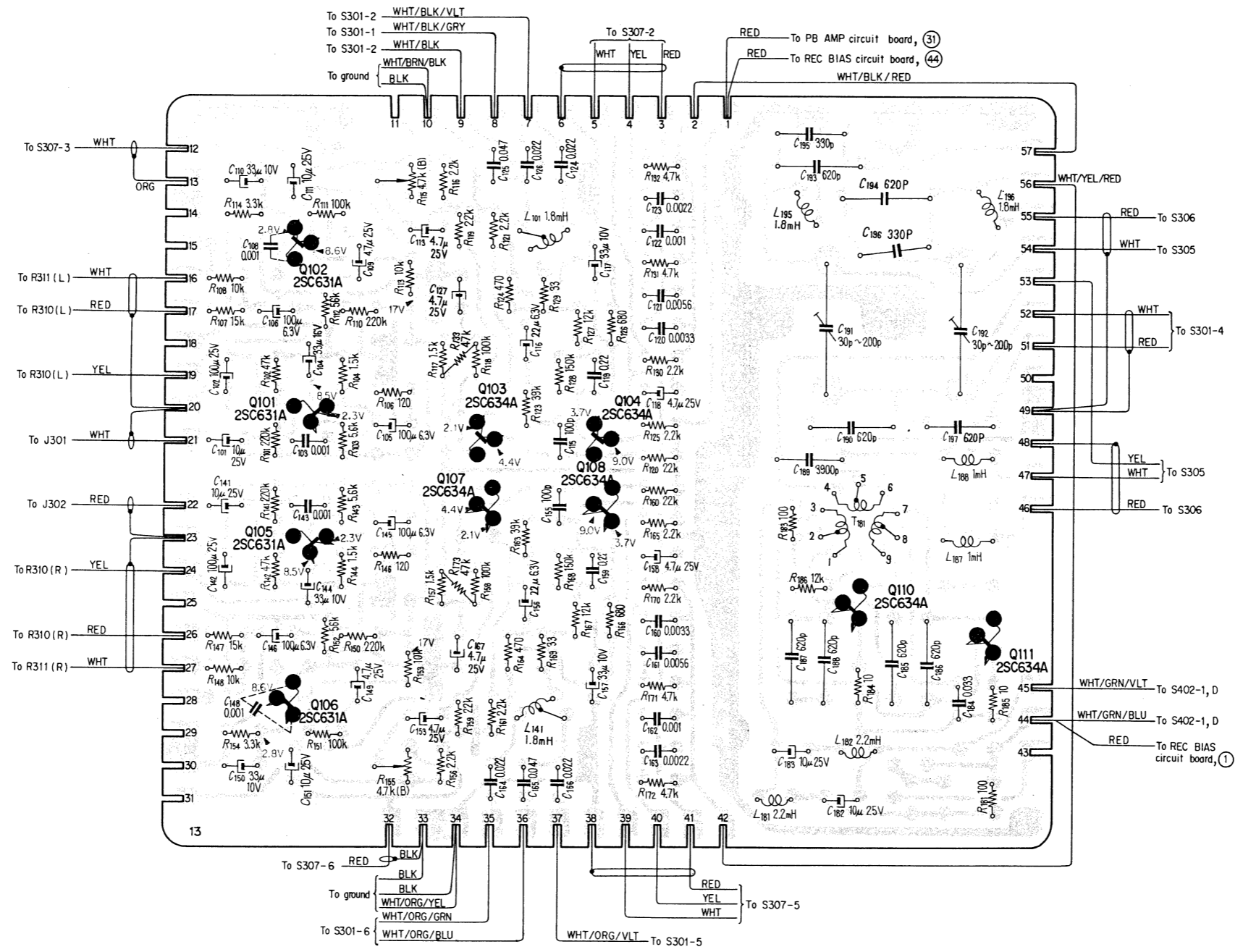

REC BIAS Circuit Board
- Component Side -

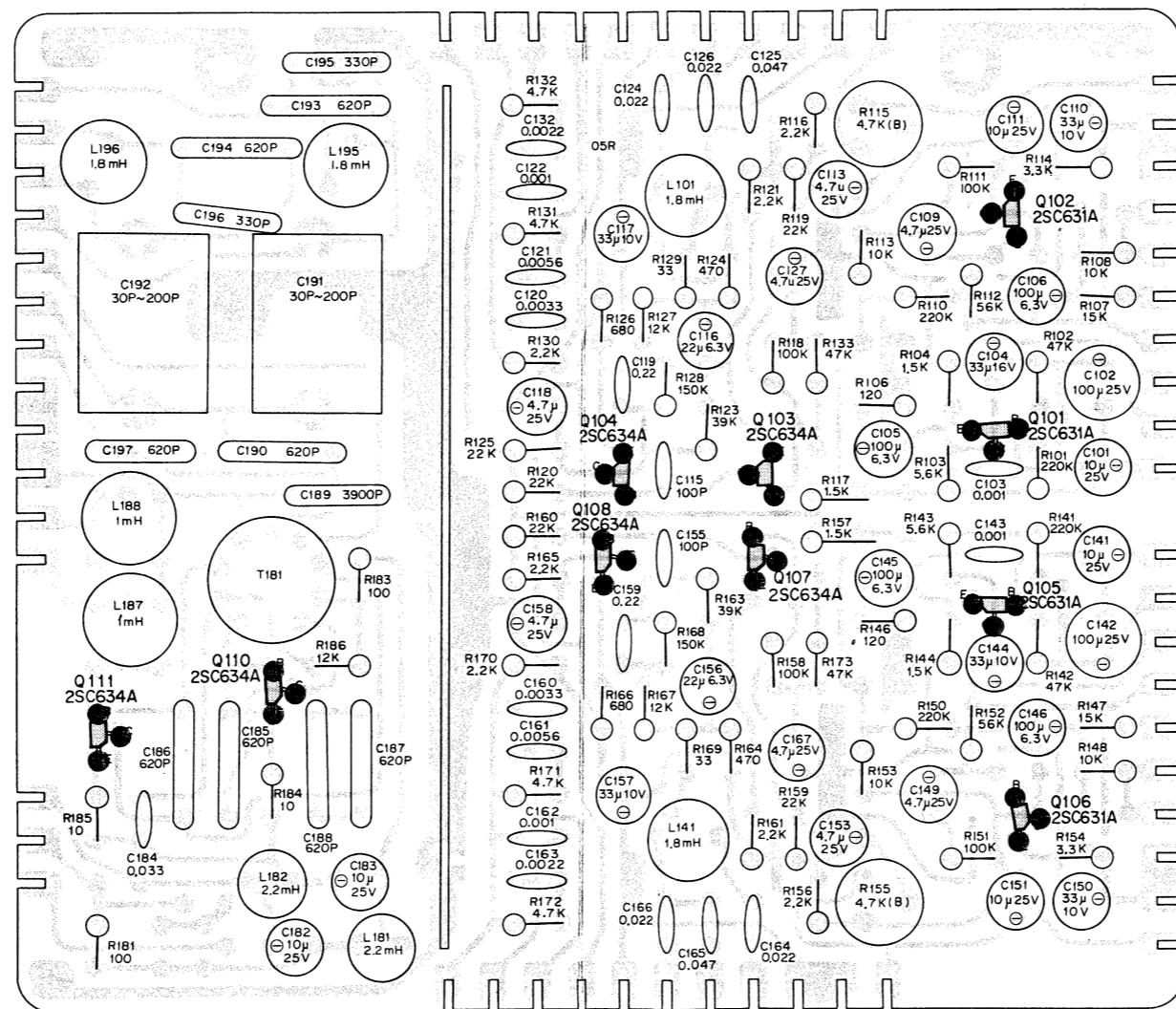

6-2-2. PB AMP Circuit Board
 - Conductor Side -

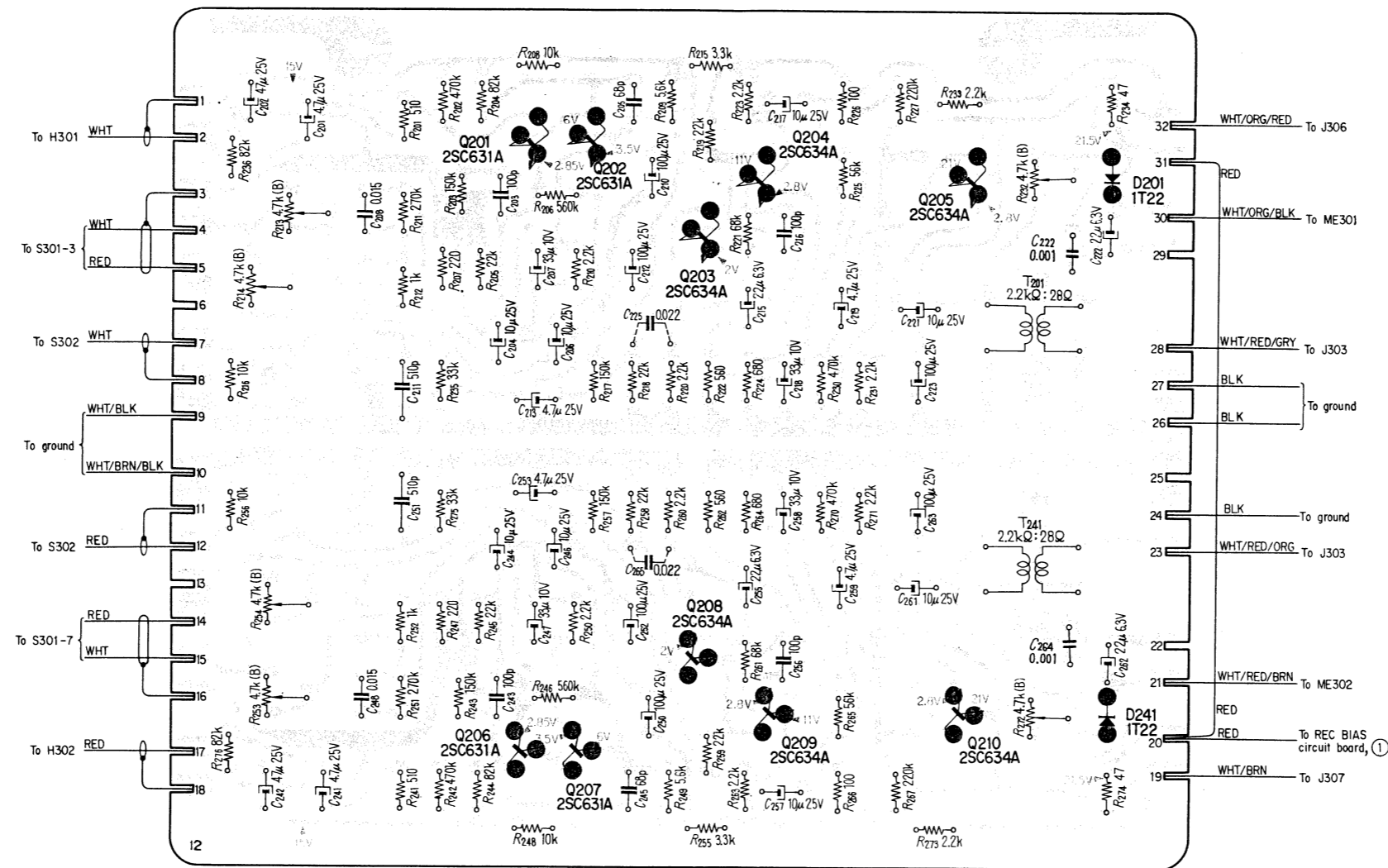

TC-640 TC-640

PB AMP Circuit Board
— Component Side —

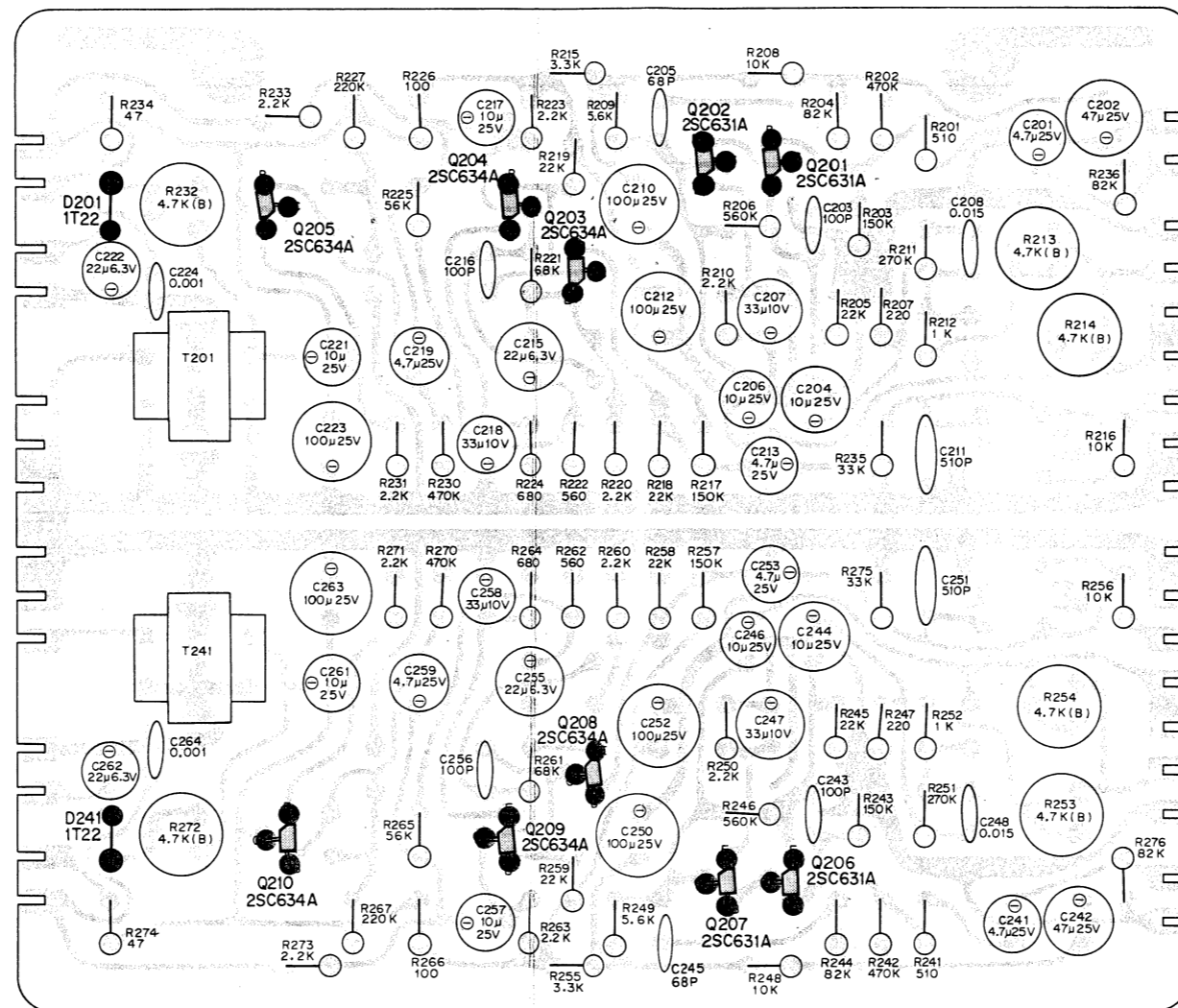

6-2-3. System Control Circuit Board
 - Conductor Side -

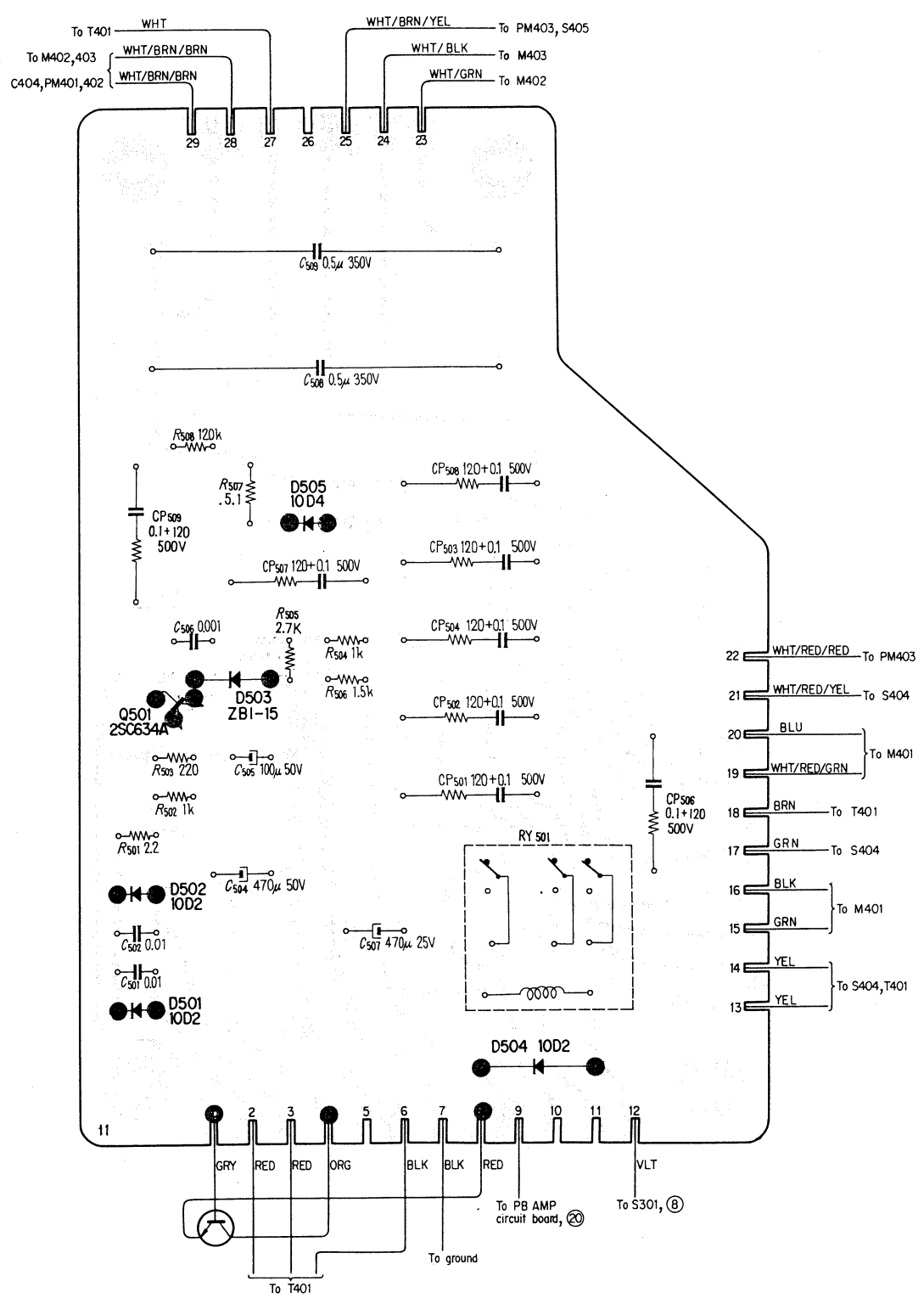

System Control Circuit Board
- Component Side -

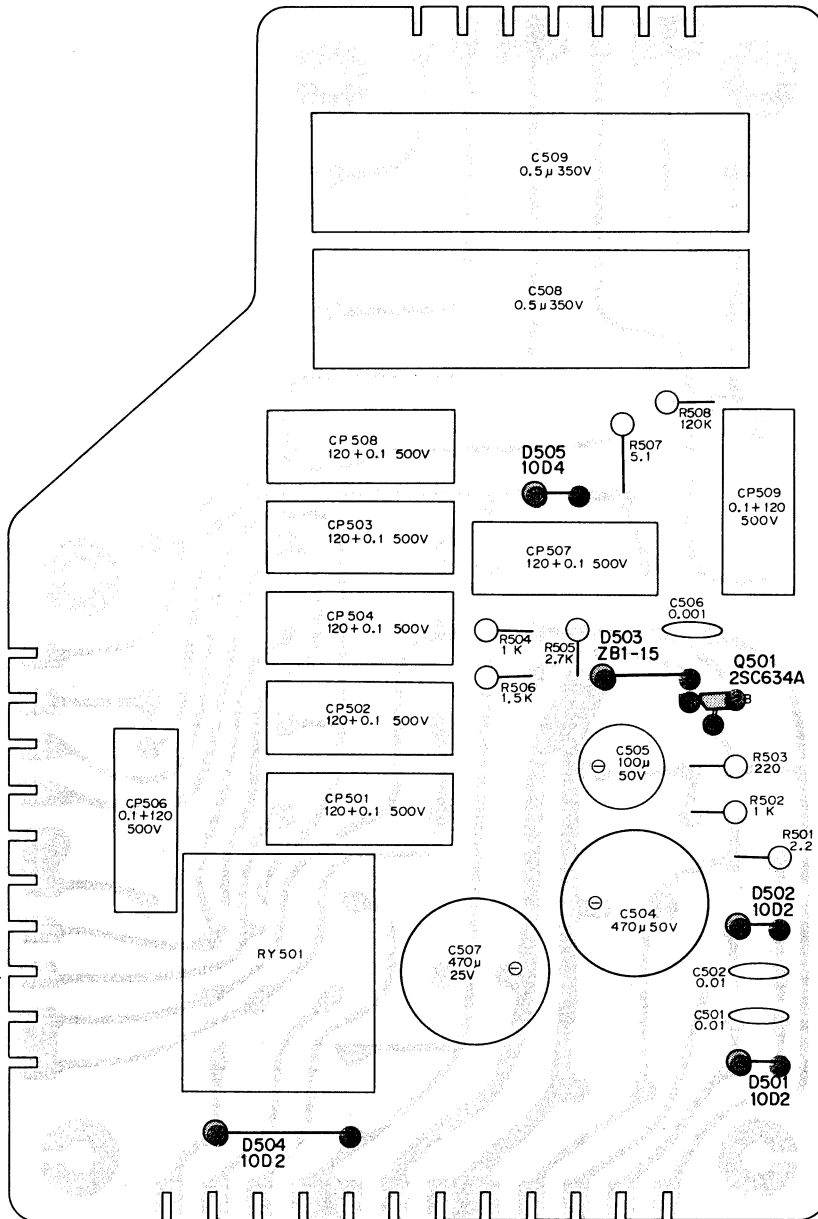

6-2-4. REC MODE Circuit Board

— Conductor Side —

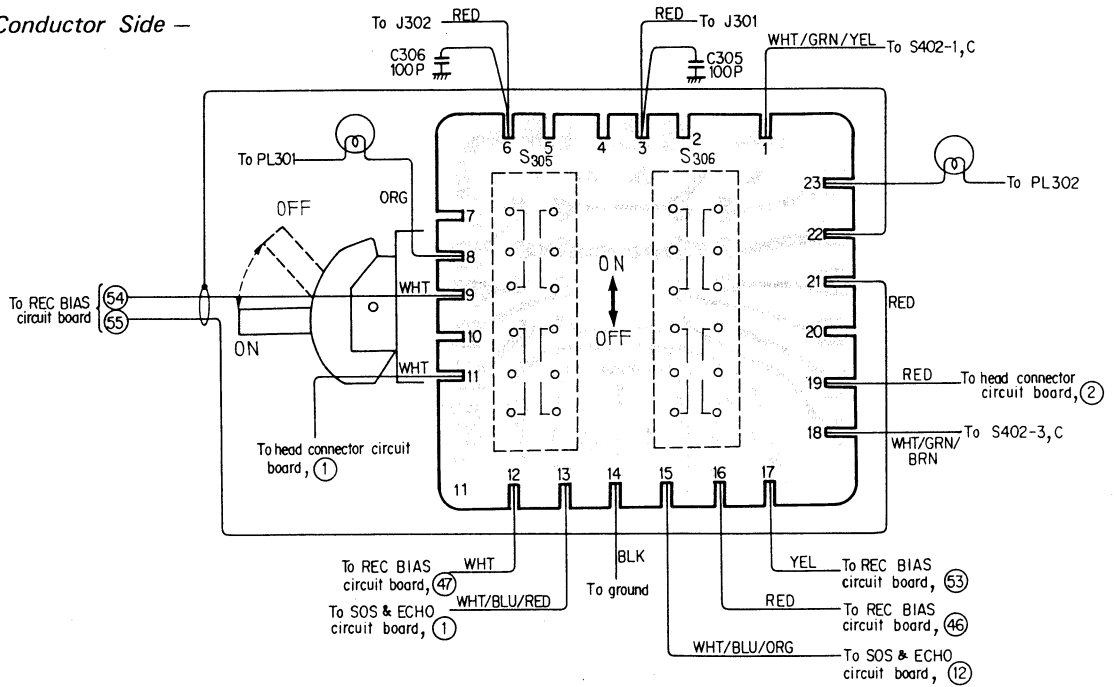

6-2-5. SOS & ECHO Circuit Board

— Conductor Side —

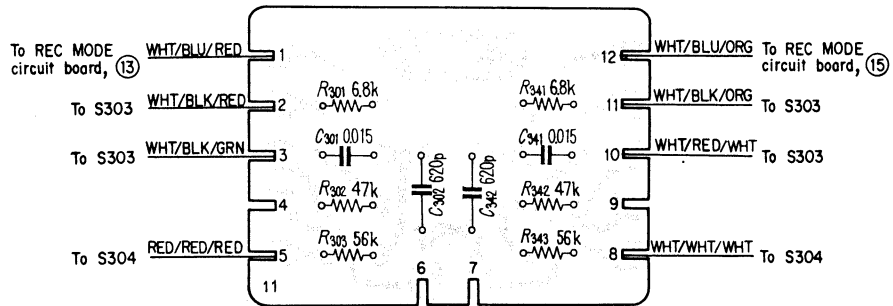

— Component Side —

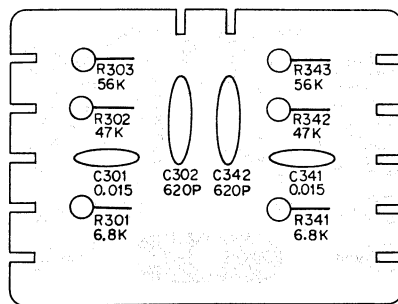

6-2-6. Resistor Terminal Circuit Board (for General Export)

— Conductor Side —

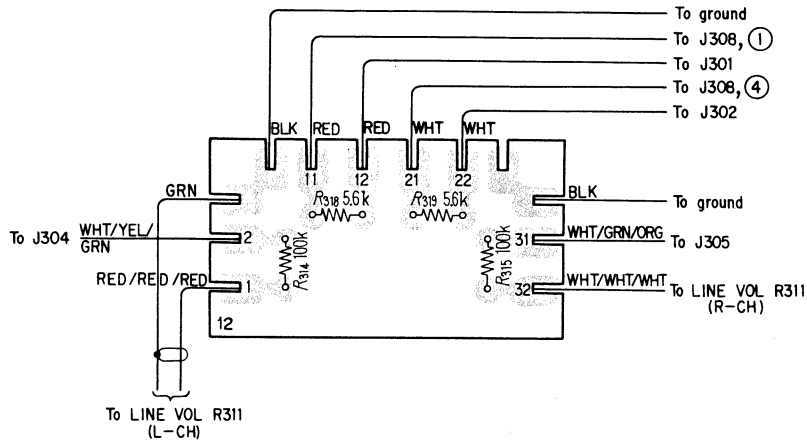

— Component Side —

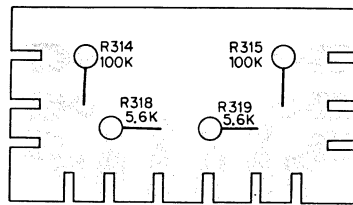

Resistor Terminal Circuit Board (for USA)

— Conductor Side —

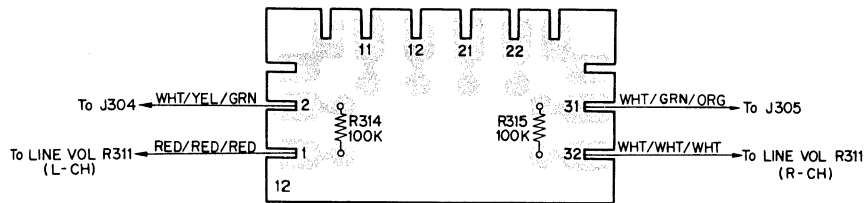

— Component Side —

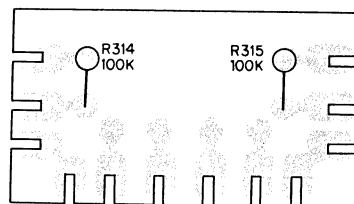

6-3. LEVEL DIAGRAM

Playback

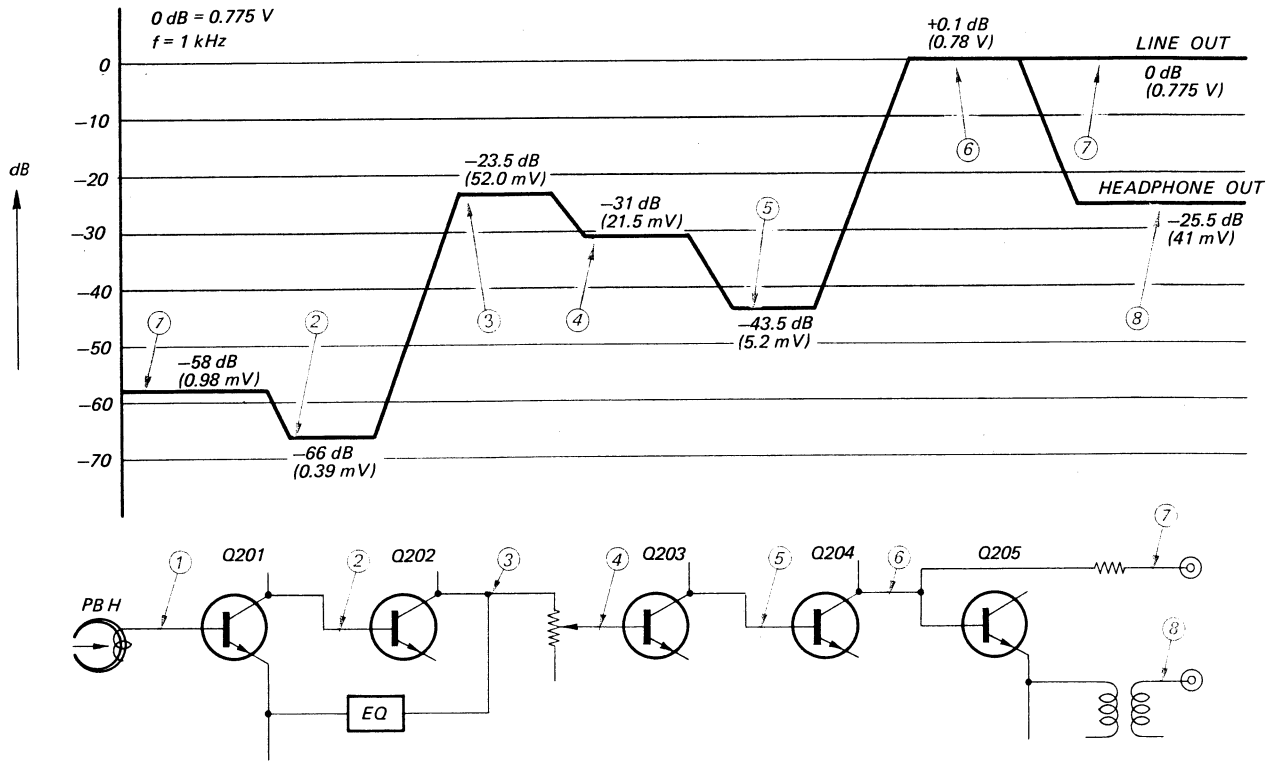

Record

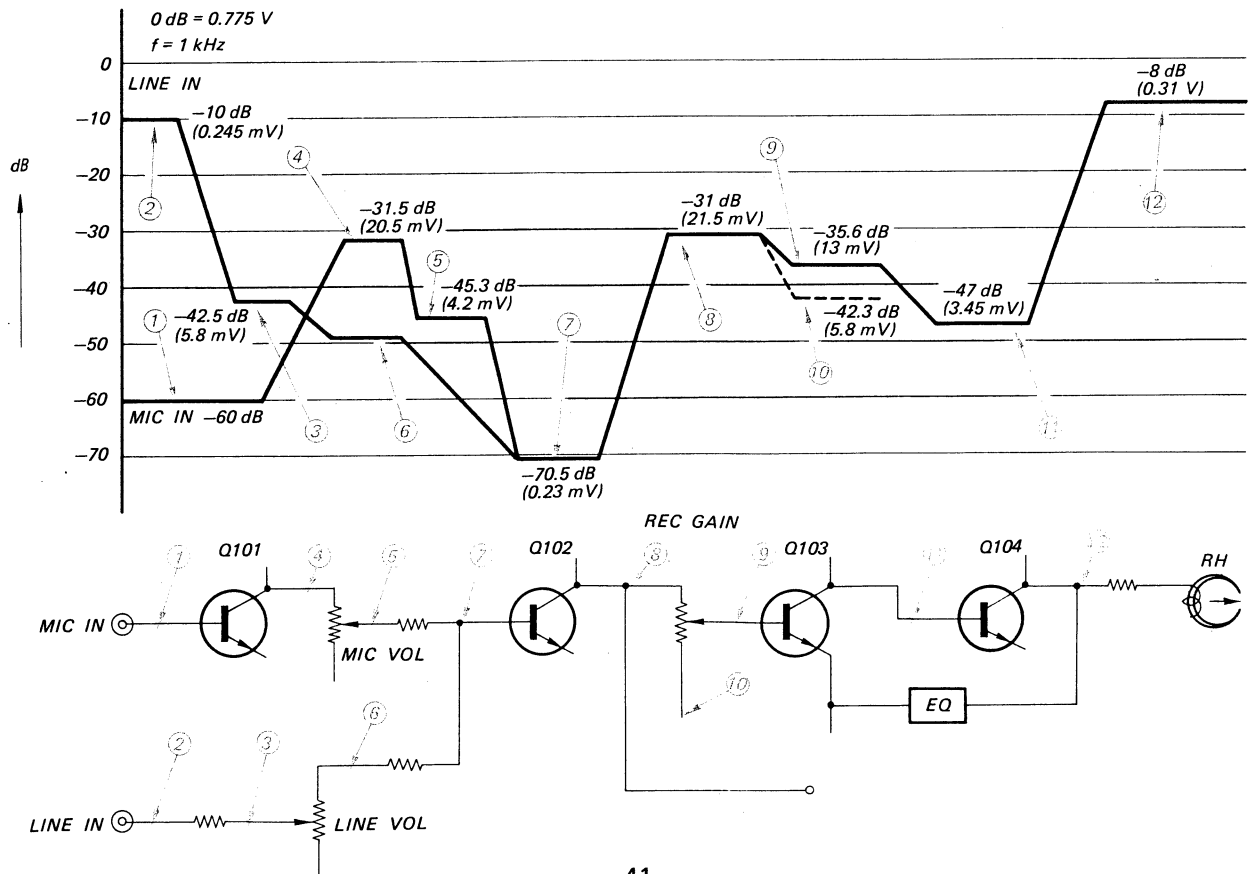

SECTION 7
SEMICONDUCTOR ELECTRODES

2SC631A, 2SC634A

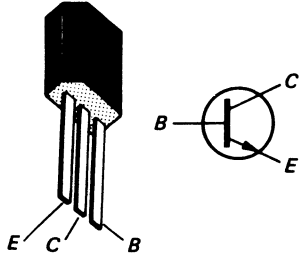

2SD291

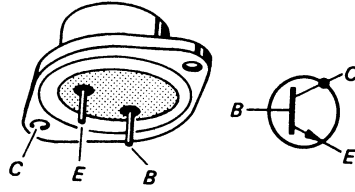

1T22

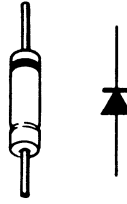

10D2, 10D4, 10D6

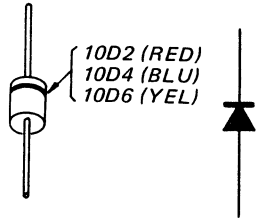

ZB1-15

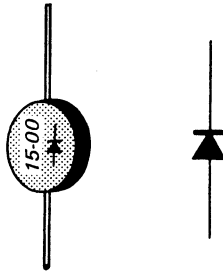

SK-1W55

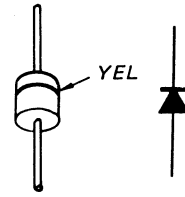

**SECTION 8
ELECTRICAL PARTS LIST**

<u>Ref. No.</u>	<u>Part No.</u>	<u>Description</u>
MOUNTED CIRCUIT BOARD		
	X-31440-51	REC BIAS
	X-31440-52	PB AMP
	X-31440-53	system control
	X-31440-54	SOS & ECHO
	X-31440-55	REC MODE
	X-31440-56	resistor terminal
PRINTED CIRCUIT BOARD		
	1-539-435	resistor terminal
	1-539-787	SOS & ECHO
	1-539-815	PB AMP
	1-539-816	REC BIAS
	1-539-817	system control
	1-539-867	REC MODE
	1-581-020	head connector
REC BIAS CIRCUIT		
SEMICONDUCTORS		
Q101, 105	transistor	2SC631A
Q102, 106	transistor	2SC631A
Q103, 107	transistor	2SC634A
Q104, 108	transistor	2SC634A
Q110	transistor	2SC634A
Q111	transistor	2SC634A
COILS AND TRANSFORMERS		
L101	1-231-069	coil, 1.8 mH
L141	1-231-069	coil, 1.8 mH
L181	1-407-198	coil, micro inductor ; 2.2 mH
L182	1-407-198	coil, micro inductor ; 2.2 mH
L187	1-409-038	coil, dummy ; 1 mH
L188	1-409-038	coil, dummy ; 1 mH
L195	1-231-069	coil, 1.8 mH
L196	1-231-069	coil, 1.8 mH
T181	1-433-148	transformer, bias osc
CAPACITORS		
All capacitors in microfarads, unless otherwise indicated. (p = μ F, elect = electrolytic)		
C101, 141	1-121-398	10 25 V elect
C102, 142	1-121-416	100 25 V elect
C103, 143	1-105-661-12	0.001 50 V mylar
C104, 144	1-121-403	33 16 V elect
C105, 145	1-121-413	100 6.3 V elect
C106, 146	1-121-413	100 6.3 V elect

<u>Ref. No.</u>	<u>Part No.</u>	<u>Description</u>
C107, 147		- discarded -
C108, 148	1-105-661-12	0.001 50 V mylar
C109, 149	1-121-395	4.7 25 V elect
C110, 150	1-121-402	33 10 V elect
C111, 151,	1-121-398	10 25 V elect
C112, 152		- discarded -
C113, 153	1-121-395	4.7 25 V elect
C114, 154		- discarded -
C115, 155	1-107-131	100 p 50 V silvered mica
C116, 156	1-121-476	22 6.3 V elect
C117, 157	1-121-402	33 10 V elect
C118, 158	1-121-395	4.7 25 V elect
C119, 159	1-105-689-12	0.22 50 V mylar
C120, 160	1-105-667-12	0.0033 50 V mylar
C121, 161	1-105-670-12	0.0056 50 V mylar
C122, 162	1-105-661-12	0.001 50 V mylar
C123, 163	1-105-665-12	0.0022 50 V mylar
C124, 164	1-105-677-12	0.022 50 V mylar
C125, 165	1-105-681-12	0.047 50 V mylar
C126, 166	1-105-677-12	0.022 50 V mylar
C127, 167	1-121-395	4.7 25 V elect
C182	1-121-398	10 25 V elect
C183	1-121-398	10 25 V elect
C184	1-105-679-12	0.033 50 V mylar
C185	1-107-028	620 p 500 V silvered mica
C186	1-107-028	620 p 500 V silvered mica
C187	1-107-028	620 p 500 V silvered mica
C188	1-107-028	620 p 500 V silvered mica
C189	1-109-508	3900 p 500 V dipped mica
C190	1-107-028	620 p 500 V silvered mica
C191	1-141-034	30~200 p1000 V trimmer
C192	1-141-034	30~200 p1000 V trimmer
C193	1-107-028	620 p 500 V silvered mica
C194	1-107-028	620 p 500 V silvered mica
C195	1-107-181	330 p 500 V silvered mica
C196	1-107-181	330 p 500 V silvered mica
C197	1-107-028	620 p 500 V silvered mica
RESISTORS		
All resistors are 1/4W and carbon type, unless otherwise indicated.		
R101, 141	1-242-729	220 k Ω
R102, 142	1-242-713	47 k Ω
R103, 143	1-242-691	5.6 k Ω
R104, 144	1-242-677	1.5 k Ω
R105, 145		- discarded -
R106, 146	1-242-651	120 Ω
R107, 147	1-242-701	15 k Ω
R108, 148	1-242-697	10 k Ω
R109, 149		- discarded -
R110, 150	1-242-729	220 k Ω
R111, 151	1-242-721	100 k Ω

<u>Ref. No.</u>	<u>Part No.</u>	<u>Description</u>
R112, 152	1-242-715	56 k Ω
R113, 153	1-242-697	10 k Ω
R114, 154	1-242-685	3.3 k Ω
R115, 155	1-221-978	4.7 k Ω (B) semi-fixed REC GAIN
R116, 156	1-242-681	2.2 k Ω
R117, 157	1-242-677	1.5 k Ω
R118, 158	1-242-721	100 k Ω
R119, 159	1-242-705	22 k Ω
R120, 160	1-242-705	22 k Ω
R121, 161	1-242-681	2.2 k Ω
R122, 162		- discarded -
R123, 163	1-242-711	39 k Ω
R124, 164	1-242-665	470 Ω
R125, 165	1-242-681	2.2 k Ω
R126, 166	1-242-669	680 Ω
R127, 167	1-242-699	12 k Ω
R128, 168	1-242-725	150 k Ω
R129, 169	1-242-637	33 Ω
R130, 170	1-242-681	2.2 k Ω
R131, 171	1-242-689	4.7 k Ω
R132, 172	1-242-689	4.7 k Ω
R133, 173	1-242-713	47 k Ω
R181	1-242-649	100 Ω
R182		- discarded -
R183	1-242-649	100 Ω
R184	1-242-625	10 Ω
R185	1-242-625	10 Ω
R186	1-242-699	12 k Ω
PB AMP CIRCUIT		
SEMICONDUCTORS		
Q201, 206	transistor	2SC631A
Q202, 207	transistor	2SC631A
Q203, 208	transistor	2SC634A
Q204, 209	transistor	2SC634A
Q205, 210	transistor	2SC634A
D201, 241	diode	1T22
TRANSFORMERS		
T201, 241	1-427-284	headphone
CAPACITORS		
All capacitors in microfarads, unless otherwise indicated. (p = μ F, elect = electrolytic)		
C201, 241	1-121-395	4.7 25 V elect
C202, 242	1-121-410	47 25 V elect
C203, 243	1-105-661-12	0.001 50 V mylar

<u>Ref. No.</u>	<u>Part No.</u>	<u>Description</u>
C204, 244	1-121-398	10 25 V elect
C205, 245	1-107-127	68 p 50 V silvered mica
C206, 246	1-121-398	10 25 V elect
C207, 247	1-121-402	33 10 V elect
C208, 248	1-105-675-12	0.015 50 V mylar
C209, 249		- discarded -
C210, 250	1-121-416	100 25 V elect
C211, 251	1-107-245	510 p 50 V silvered mica
C212, 252	1-121-416	100 25 V elect
C213, 253	1-121-395	4.7 25 V elect
C214, 254		- discarded -
C215, 255	1-121-476	22 6.3 V elect
C216, 256	1-107-131	100 p 50 V silvered mica
C217, 257	1-121-398	10 25 V elect
C218, 258	1-121-402	33 10 V elect
C219, 259	1-121-395	4.7 25 V elect
C220, 260		- discarded -
C221, 261	1-121-398	10 25 V elect
C222, 262	1-121-476	22 6.3 V elect
C223, 263	1-121-416	100 25 V elect
C224, 264	1-105-661-12	0.001 50 V mylar
C225, 265	1-105-677-12	0.022 50 V mylar
RESISTORS		
All resistors are 1/4W and carbon type, unless otherwise indicated.		
R201, 241	1-242-666	510 Ω
R202, 242	1-242-737	470 k Ω
R203, 243	1-242-725	150 k Ω
R204, 244	1-242-719	82 k Ω
R205, 245	1-242-705	22 k Ω
R206, 246	1-242-739	560 k Ω
R207, 247	1-242-657	220 Ω
R208, 248	1-242-697	10 k Ω
R209, 249	1-242-691	5.6 k Ω
R210, 250	1-242-681	2.2 k Ω
R211, 251	1-242-731	270 k Ω
R212, 252	1-242-673	1 k Ω
R213, 253	1-221-978	4.7 k Ω (B) semi-fixed PB 19 cm/s EQ
R214, 254	1-221-978	4.7 k Ω (B) semi-fixed PB 9.5 cm/s EQ
R215, 255	1-242-685	3.3 k Ω
R216, 256	1-242-697	10 k Ω
R217, 257	1-242-725	150 k Ω
R218, 258	1-242-705	22 k Ω
R219, 259	1-242-705	22 k Ω
R220, 260	1-242-681	2.2 k Ω
R221, 261	1-242-717	68 k Ω
R222, 262	1-242-667	560 Ω
R223, 263	1-242-681	2.2 k Ω
R224, 264	1-242-669	680 Ω

Ref. No.	Part No.	Description
R225, 265	1-242-715	56 kΩ
R226, 266	1-242-649	100 Ω
R227, 267	1-242-729	220 kΩ
R228, 268		— discarded —
R229, 269		— discarded —
R230, 270	1-242-737	470 kΩ
R231, 271	1-242-681	2.2 kΩ
R232, 272	1-221-978	4.7 kΩ (B) semi-fixed VU Meter ADJ.
R233, 273	1-242-681	2.2 kΩ
R234, 274	1-242-641	47 Ω
R235, 275	1-242-709	33 kΩ
R236, 276	1-242-719	82 kΩ

AMP CHASSIS CIRCUIT

CAPACITORS

C301, 341	1-105-675-12	0.015 μF 50 V	mylar
C302, 342	1-107-247	620 pF 50 V	silvered mica
C303	1-105-679-12	0.033 μF 50 V	mylar
C304	1-105-679-12	0.033 μF 50 V	mylar
C305	1-107-131	100 pF 50 V	silvered mica
C306	1-107-131	100 pF 50 V	silvered mica
	1-106-066-12	0.0022 μF 50 V	mylar (for General Export)

RESISTORS

All resistors are 1/4W and carbon type unless otherwise indicated.

R301, 341	1-242-693	6.8 kΩ
R302, 342	1-242-713	47 kΩ
R303, 343	1-242-715	56 kΩ
R304		— discarded —
R305		— discarded —
R306	1-242-685	3.3 kΩ
R307	1-242-685	3.3 kΩ
R308	1-242-668	620 Ω (for USA)
	1-242-687	3.9 kΩ (for General Export)
R309	1-242-668	620 Ω (for USA)
	1-242-687	3.9 kΩ (for General Export)
R310	1-222-438	10 kΩ (A) variable MIC VOL
R311	1-222-438	10 kΩ (A) variable LINE VOL
R312	1-222-438	10 kΩ (A) variable PB VOL
R313	1-222-436	50 kΩ (A) variable SOS & ECHO VOL w/switch
R314	1-242-721	100 kΩ
R315	1-242-721	100 kΩ
R316	1-242-695	8.2 kΩ
R317	1-242-695	8.2 kΩ
R318	1-242-691	5.6 kΩ (for General Export)
R319	1-242-691	5.6 kΩ (for General Export)
	1-242-701	15 kΩ (for General Export)

Ref. No.	Part No.	Description
JACKS		
J301	1-507-281	microphone (L-CH)
J302	1-507-281	microphone (R-CH)
J303	1-507-282	binaural, headphone
J304	1-507-142	phono, line input (L-CH)
J305	1-507-142	phono, line input (R-CH)
J306	1-507-142	phono, line output (L-CH)
J307	1-507-142	phono, line output (R-CH)
J308	1-509-029	connector, REC/PB (for General Export)

SWITCHES

S301	1-514-789	slide, tape speed
S302	1-514-692	lever, monitor
S303	1-514-324	slide, SOS & ECHO
S304		built in R313
S305	1-514-769	lever, REC MODE (L-CH)
S306	1-514-769	lever, REC MODE (R-CH)
S307	1-513-347	slide, tape select

MISCELLANEOUS

PL301	1-518-093-11	lamp, REC MODE (L-CH)
PL302	1-518-093-11	lamp, REC MODE (R-CH)
PL303	1-518-093-11	lamp, REC
PL304		lamp (built in ME301)
PL305		lamp (built in ME302)
ME301	1-524-077	meter, VU (w/lamp PL304)
ME302	1-524-077	meter, VU (w/lamp PL305)

HEAD CHASSIS CIRCUIT

H301, 302	8-829-142-20	head, playback (PP102-4202)
H303, 304	8-824-629-20	head, record (RP102-2902)
H305, 306	8-826-629-25	head, erase (EF18-2902A)

MECHANICAL CHASSIS CIRCUIT

SEMICONDUCTORS

Q401		transistor	2SD291
D401		diode	10D2
D402		diode	10D6
D403		diode	10D2
D404		diode,	zener SK-1W55

CAPACITORS

C401	1-117-040	2 + 0.5 μF 300 V	metalized paper
C402	1-117-083	4 + 1 μF 250 V	metalized paper
C403	1-117-083	4 + 1 μF 250 V	metalized paper
C404	1-121-004	220 μF 160 V	electrolytic

Ref. No.	Part No.	Description
C405	1-115-079	0.1 μF 400 V paper
C406	1-115-079	0.1 μF 400 V paper

RESISTORS

R401	1-205-503	68 Ω 40 W wirewound
R402	1-205-518	220 Ω 40 W wirewound
R403	1-205-506	1 kΩ 20 W wirewound

SWITCHES

S401	1-514-140-13	push, power (for General Export)
	1-514-140-23	push, power (for USA)
S402	1-514-811	lever, function
S403	1-514-057	micro, play
S404	1-514-730	micro, pinch roller
S405	1-514-057	micro, SHUT-OFF
S406	1-514-058-00	micro, INSTANT STOP (for General Export)
	1-514-058-01	micro, INSTANT STOP (for USA)
S407	1-514-324-11	slide, power frequency (for General Export)

JACKS

CNJ401	1-509-062	socket, power supply
CNJ402	1-509-341	socket, AC outlet
J403	1-509-064	socket, voltage selector (for General Export)

MOTORS

M401	8-831-634-13	capstan (HC634D5)
M402	1-541-033-21	supply reel (CM-71)
M403	1-541-033-21	take-up reel (CM-71)

SOLENOIDS

PM401	1-454-080	pinch roller
	3-144-178	pole piece
PM402	1-454-079	brake
	3-144-179	pole piece
PM403	1-454-078	shut-off
	3-144-180	pole piece

MISCELLANEOUS

T401	1-441-680	transformer, power (for USA)
T401	1-441-694	transformer, power (for General Export)
CP401, 403	1-101-534	encapsulated components C-R
CP404, 405		0.1 μF + 120 Ω 500 V
F401	1-532-100	fuse, 2A
	1-533-048	holder, fuse
	1-535-506-11	connector, wire
	1-535-506-21	connector, wire
	1-536-179	lug, terminal; 1L1
	1-536-213	lug, terminal plate; 5P

SYSTEM CONTROL CIRCUIT

SEMICONDUCTORS

Q501		transistor	2SC634A
D501		diode	10D2
D502		diode	10D2
D503		diode	ZB1-15
D504		diode	10D2
D505		diode	10D4

CAPACITORS

C501	1-105-753-12	0.01 μF 200 V	mylar
C502	1-105-753-12	0.01 μF 200 V	mylar
C503		— discarded —	
C504	1-121-810	470 μF 50 V	electrolytic
C505	1-121-378	100 μF 50 V	electrolytic
C506	1-105-661-12	0.001 μF 50 V	mylar
C507	1-121-733	470 μF 25 V	electrolytic
C508	1-117-054	0.5 μF 350 V	metalized paper
C509	1-117-054	0.5 μF 350 V	metalized paper

RESISTORS

R501	1-257-809	2.2 Ω 1/2W	carbon
R502	1-257-873	1 kΩ 1/2W	carbon
R503	1-242-657	220 Ω 1/4W	carbon
R504	1-242-673	1 kΩ 1/4W	carbon
R505	1-242-683	2.7 kΩ 1/4W	carbon
R506	1-242-677	1.5 kΩ 1/4W	carbon
R507	1-207-210	5.1 Ω	wirewound
R508	1-257-923	120 kΩ 1/2W	carbon

MISCELLANEOUS

CP501	1-101-534	encapsulated component C-R	0.1 μF + 120 Ω 500 V
CP502	1-101-534	encapsulated component C-R	0.1 μF + 120 Ω 500 V
CP503	1-101-534	encapsulated component C-R	0.1 μF + 120 Ω 500 V
CP504	1-101-534	encapsulated component C-R	0.1 μF + 120 Ω 500 V
CP505		— discarded —	
CP506	1-101-534	encapsulated component C-R	0.1 μF + 120 Ω 500 V
CP507	1-101-534	encapsulated component C-R	0.1 μF + 120 Ω 500 V
CP508	1-101-534	encapsulated component C-R	0.1 μF + 120 Ω 500 V
CP509	1-101-534	encapsulated component C-R	0.1 μF + 120 Ω 500 V
RY501	1-515-127	relay	

9-4. HEAD DECK – Top View (2) –

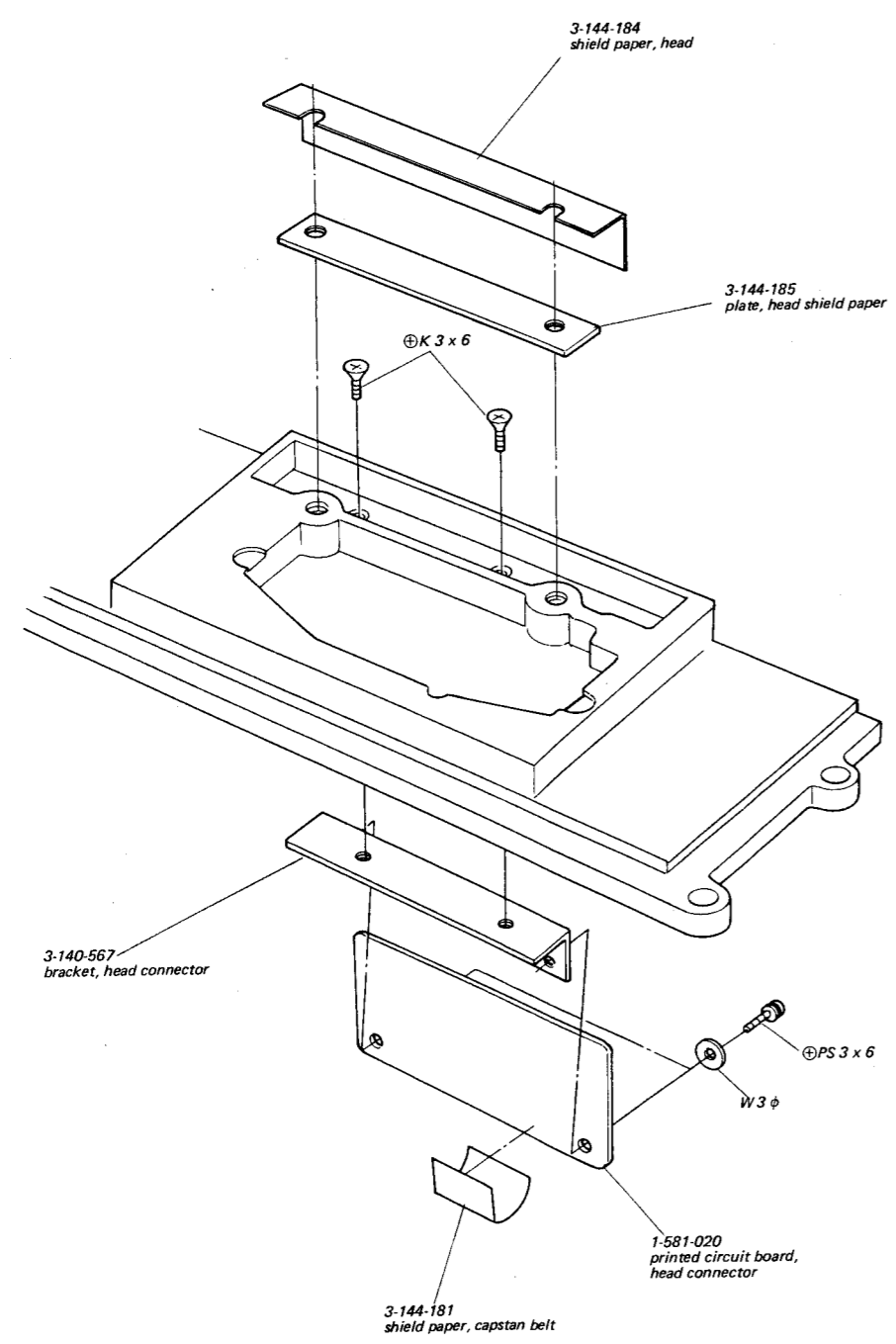

9-5. PRINTED CIRCUIT BOARD – Top View –

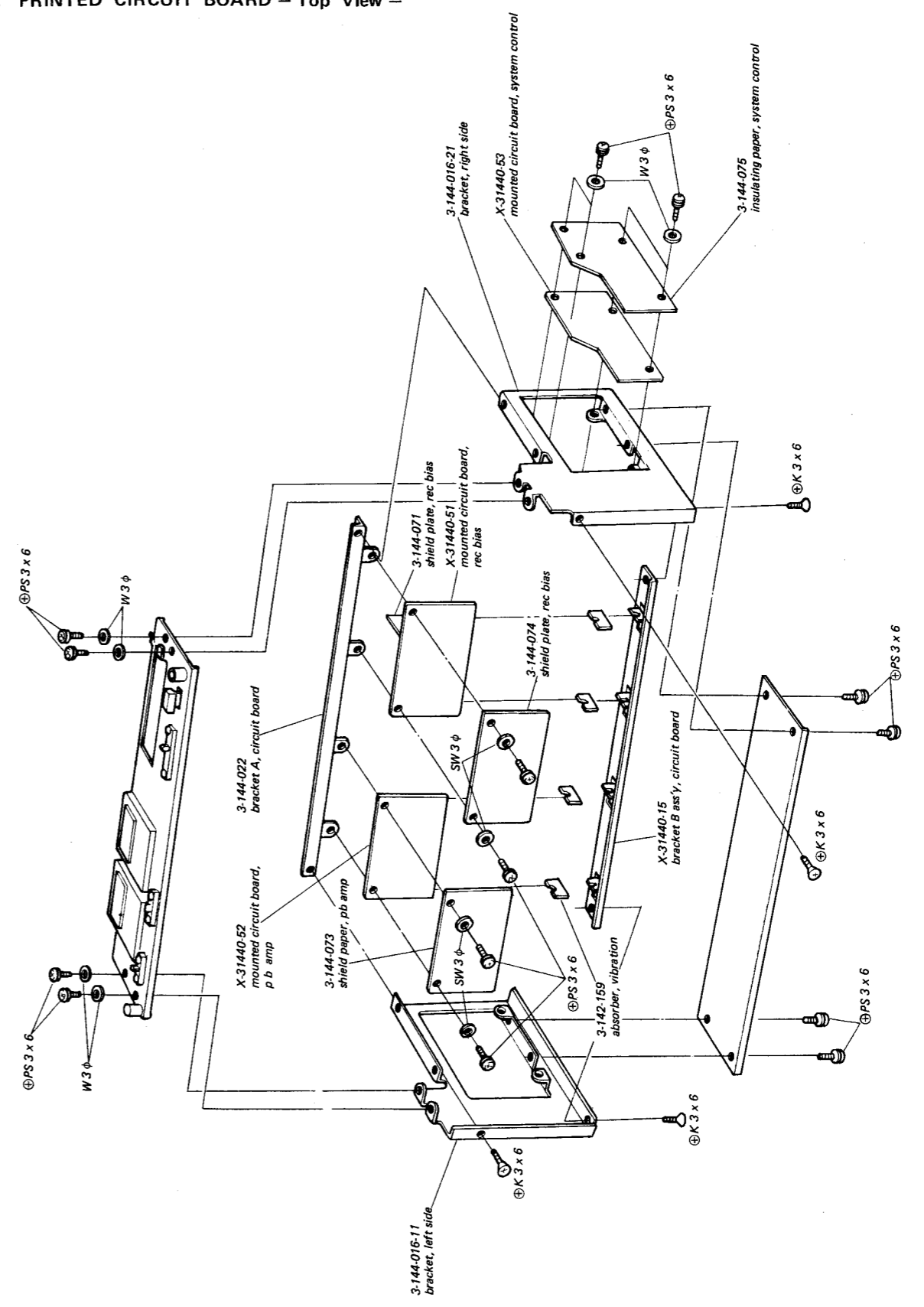

TC-640 TC-640

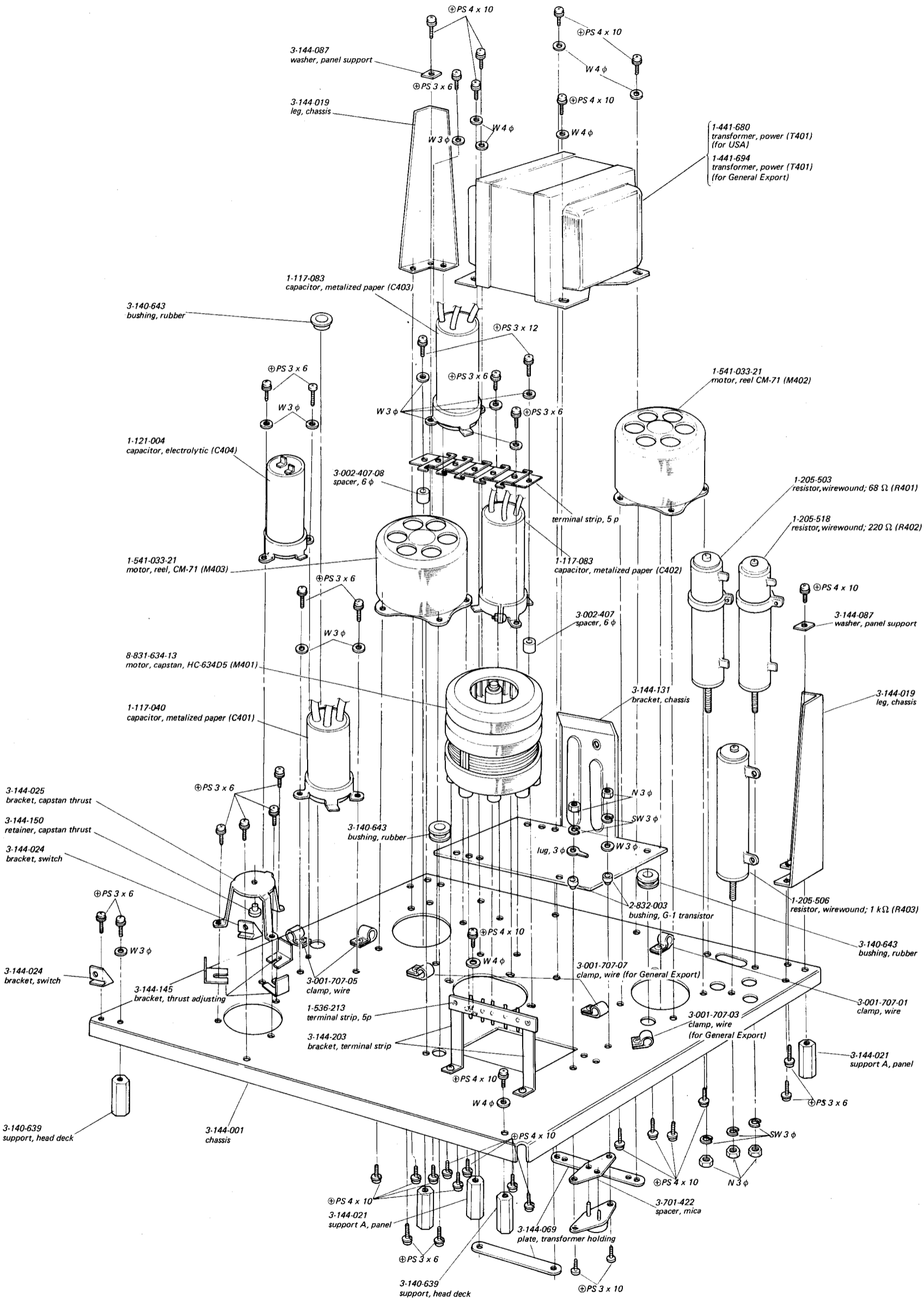

TC-640 TC-640

**SECTION 10
HARDWARES**

PACKING (for USA)

<u>Part No.</u>	<u>Description</u>	<u>Part No.</u>	<u>Description</u>
7-621-770-88	⊕B 2.6 x 6	7-623-105-24	2 φ
7-621-842-39	⊕RK 2.7 x 10, wood	7-623-107-24	2.6 φ
7-682-124-02	⊕P 2 x 4	7-623-108-04	3 φ (small)
7-682-126-02	⊕P 2 x 6	7-623-108-24	3 φ
7-682-130-02	⊕P 2 x 14	7-623-110-24	4 φ
7-682-147-04	⊕P 3 x 6	7-623-205-21	2 φ , spring
7-682-152-02	⊕P 3 x 16	7-623-207-21	2.6 φ
7-682-166-02	⊕P 4 x 30	7-623-208-21	3 φ
7-682-168-02	⊕P 4 x 20	7-623-210-21	4 φ
7-682-225-02	⊕K 2 x 5		
7-682-226-02	⊕K 2 x 6		
7-682-247-02	⊕K 3 x 6		
7-682-248-02	⊕K 3 x 8		
7-682-259-33	⊕P 2.6 x 5		
7-682-348-04	⊕RK 3 x 8		
7-682-355-04	⊕RK 3 x 30		
7-682-367-04	⊕RK 4 x 25		
7-682-526-02	⊕B 2 x 6		
7-682-547-05	⊕B 3 x 6		
7-682-548-05	⊕B 3 x 8		
7-682-565-05	⊕B 4 x 16		
7-682-645-02	⊕PS 3 x 4		
7-682-647-02	⊕PS 3 x 6		
7-682-649-02	⊕PS 3 x 10		
7-682-650-02	⊕PS 3 x 12		
7-682-651-02	⊕PS 3 x 14		
7-682-662-02	⊕PS 4 x 10		
7-682-663-02	⊕PS 4 x 12		
7-683-127-31	2 x 4, set; hexagon socket		
7-683-138-31	3 x 4, set; hexagon socket		
7-683-247-31	4 x 6, set; hexagon socket		

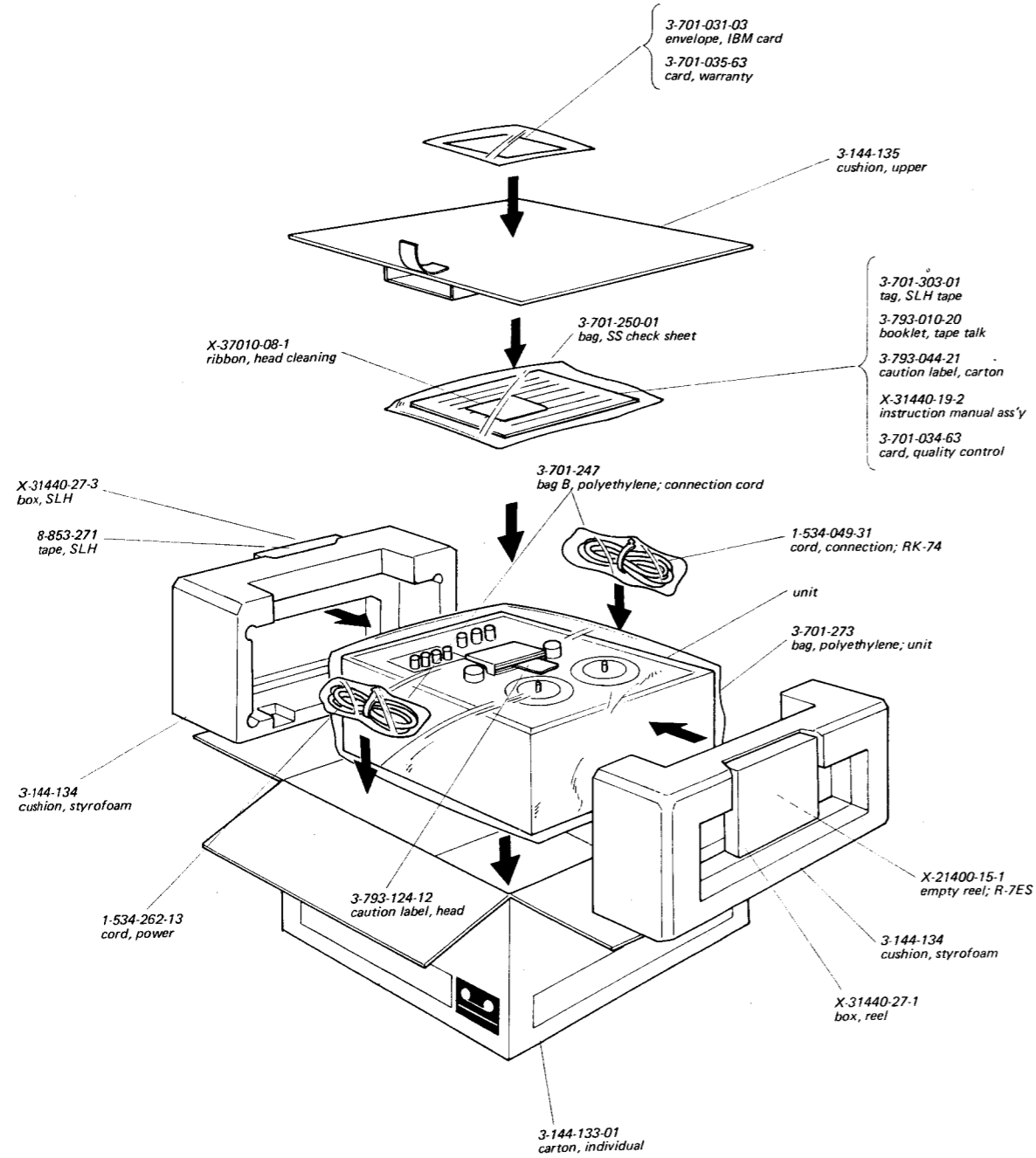

WASHERS

RETAINING RINGS

NUTS

Hardware Nomenclature

P — Pan Head Screw		E — Retaining Ring (E Washer)	
K — Flat Countersunk Head Screw		W — Washer	
B — Binding Head Screw		SW — Spring Washer	
RK — Oval Countersunk Head Screw		LW — Lock Washer	
T — Truss Head Screw		N — Nut	
R — Round Head Screw			
F — Flat Fillister Head Screw			
SC — Set Screw			

Example	
⊕ P 3 x 10	

When ordering replacement parts, you should use PART NUMBER listed on the Parts Lists or shown in the EXPLODED VIEW. The reference number should not be used for ordering purposes.