

TC-707S/SD

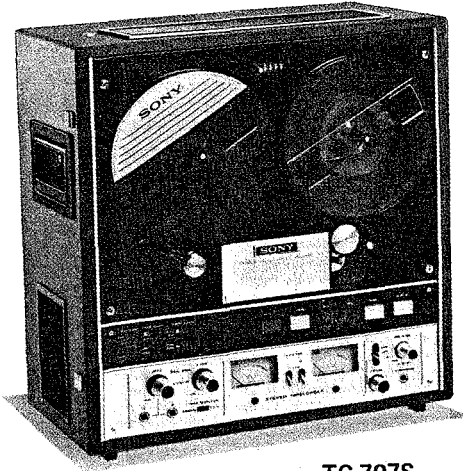

TC-707S



TC-707SD

Canadian Model
AEP Model
E Model

REVISED

STEREO
TAPECORDER

TC-707S	Serial No. 1261 to 1440. Serial No. 11501 to 11600. Serial No. 11601 and later.
TC-707SD	Serial No. 1353 to 1592. Serial No. 11601 to 11950. Serial No. 11951 and later.

SPECIFICATIONS

Power Requirements: AC 100V, 110V, 121V, 220V, 240V
50/60 Hz, 90W

Track System: Two-track stereo and mono

Reel Size: 7" (18 cm) maximum

Tape Speed: 7½ ips and 3¾ ips
(19 cm/s and 9.5 cm/s)

Recording Time:

(with 1,800 ft. tape)

Tape speed	Time
7½ ips (19 cm/s)	45 min.
3¾ ips (9.5 cm/s)	1.5 hrs

Frequency Response: 20 ~ 25,000 Hz at 7½ ips (19 cm/s)
20 ~ 18,000 Hz at 3¾ ips (9.5 cm/s)
(with standard tape)
20 ~ 30,000 Hz at 7½ ips (19 cm/s)
20 ~ 20,000 Hz at 3¾ ips (9.5 cm/s)
(with SONY SLH tape)

Signal-to-Noise Ratio: 54 dB (with standard tape)
57 dB (with SONY SLH tape)

Wow and Flutter: 0.04% at 7½ ips (19 cm/s)
0.1% at 3¾ ips (9.5 cm/s)

Record Bias Frequency: Approx. 120 kHz

Inputs: Two MIC inputs
Impedance: 600Ω
Maximum sensitivity: 0.19 mV (-72 dB)

Two LINE INputs
Impedance: 100 kΩ
Maximum sensitivity: 0.06V (-22 dB)

Outputs: Two LINE OUTputs
Impedance: 100 kΩ or more
Output level: 0.775V (0 dB)
HEADPHONE output
Load impedance: 8Ω
Output level: 0.037V (-26.5 dB)

Semiconductors: 44 transistors and 51 diodes

Dimensions: TC-707S: 16⁶/₆₄ (W) x 17²/₃₂ (H) x 10³/₄" (D)
(430 x 453 x 271 mm)

TC-707SD: 14⁷/₈ (W) x 16³/₆₄ (H) x 9¹/₄" (D)
(378 x 408 x 234 mm)

Weight: TC-707S: 49 lb 6 oz (22.4 kg)
TC-707SD: 42 lb 13 oz (19.4 kg)

SONY
SERVICE MANUAL

SECTION 1
OUTLINE

1-1. BLOCK DIAGRAM

— System Control Circuit —

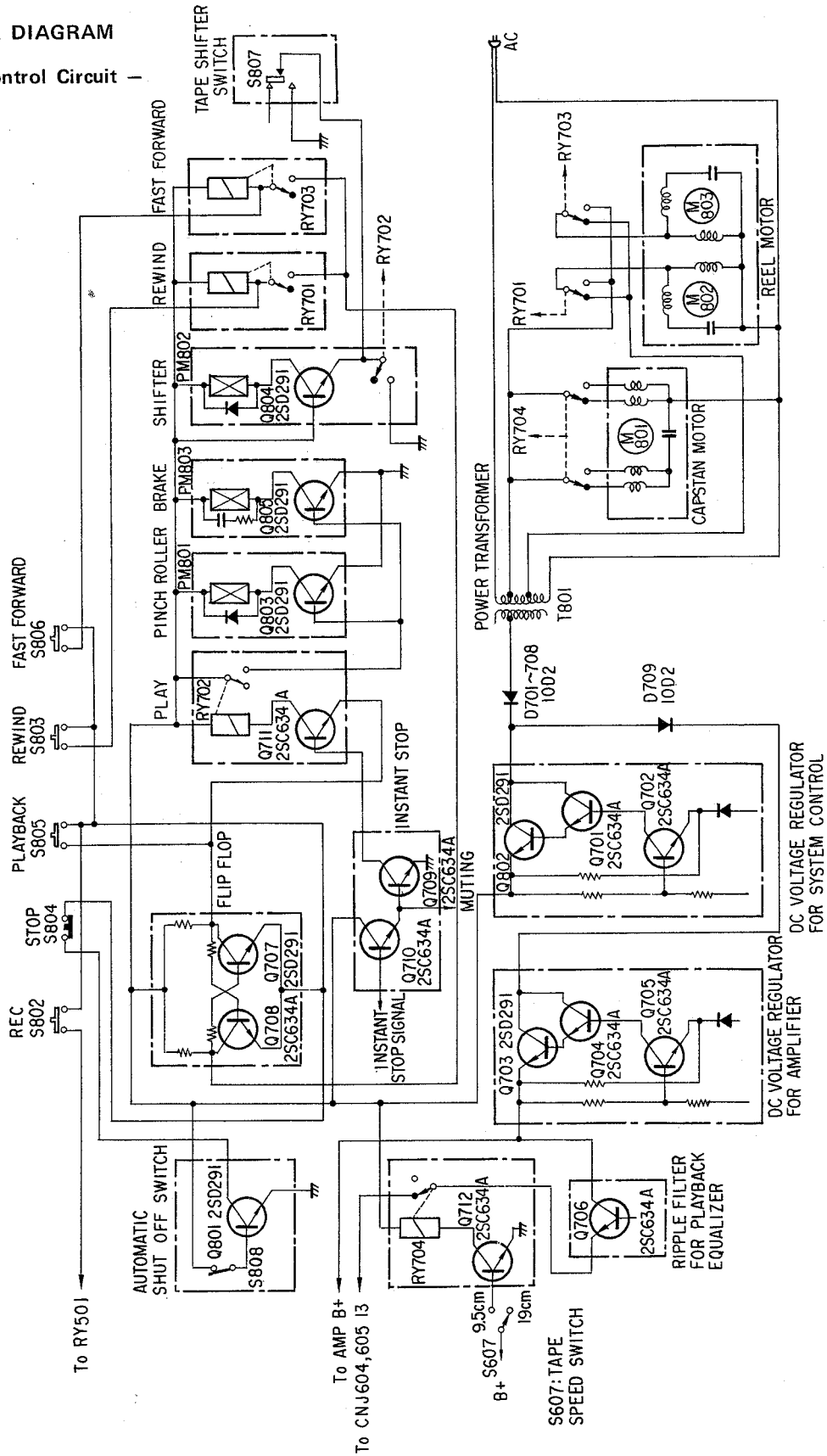

- Audio Amp and Bias Osc Circuit -

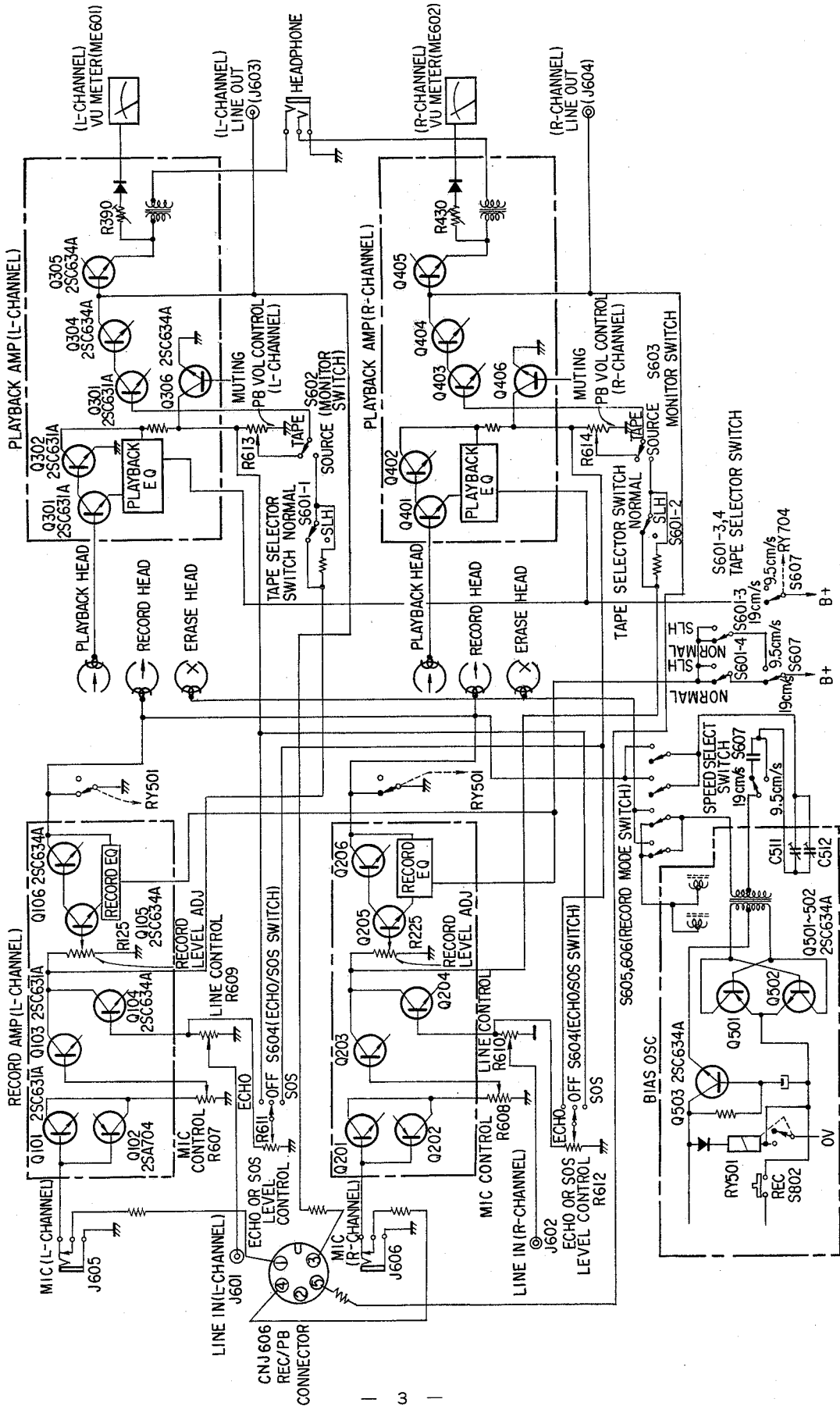

TC-707S/SD

1-2. MAJOR PARTS LOCATIONS

Cabinet — Top View —

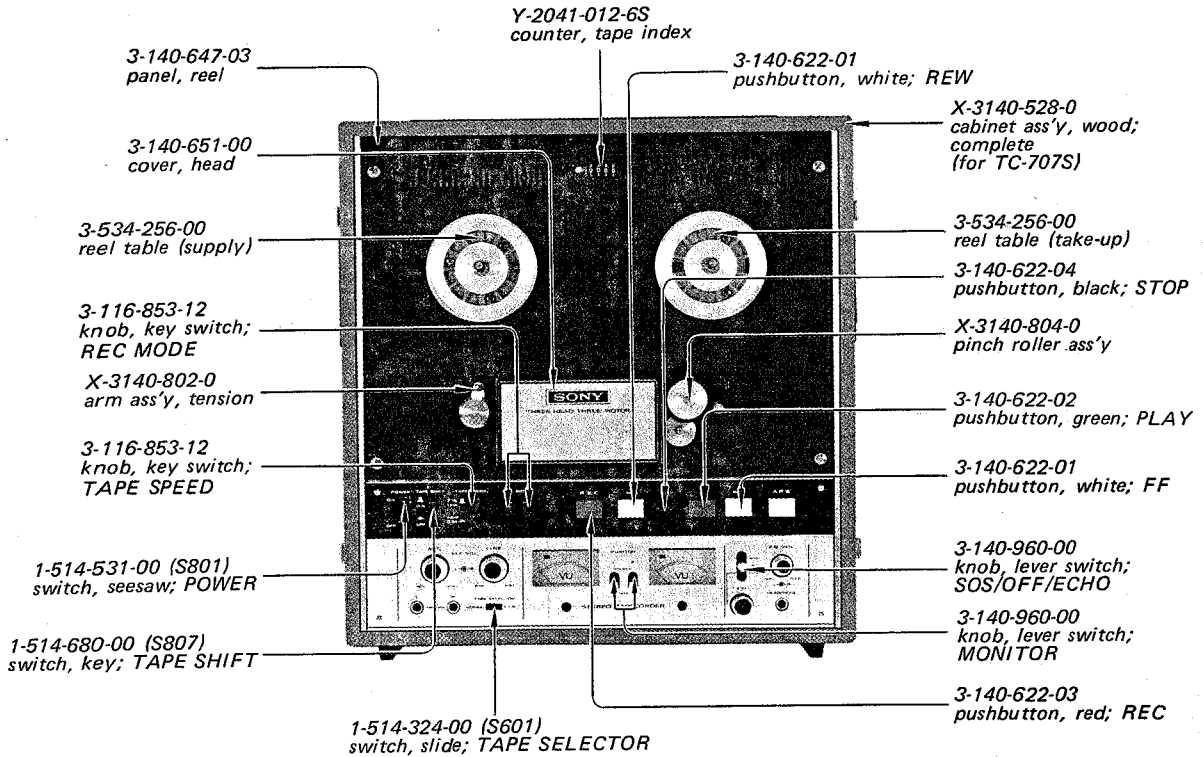

Cabinet — Side Views —

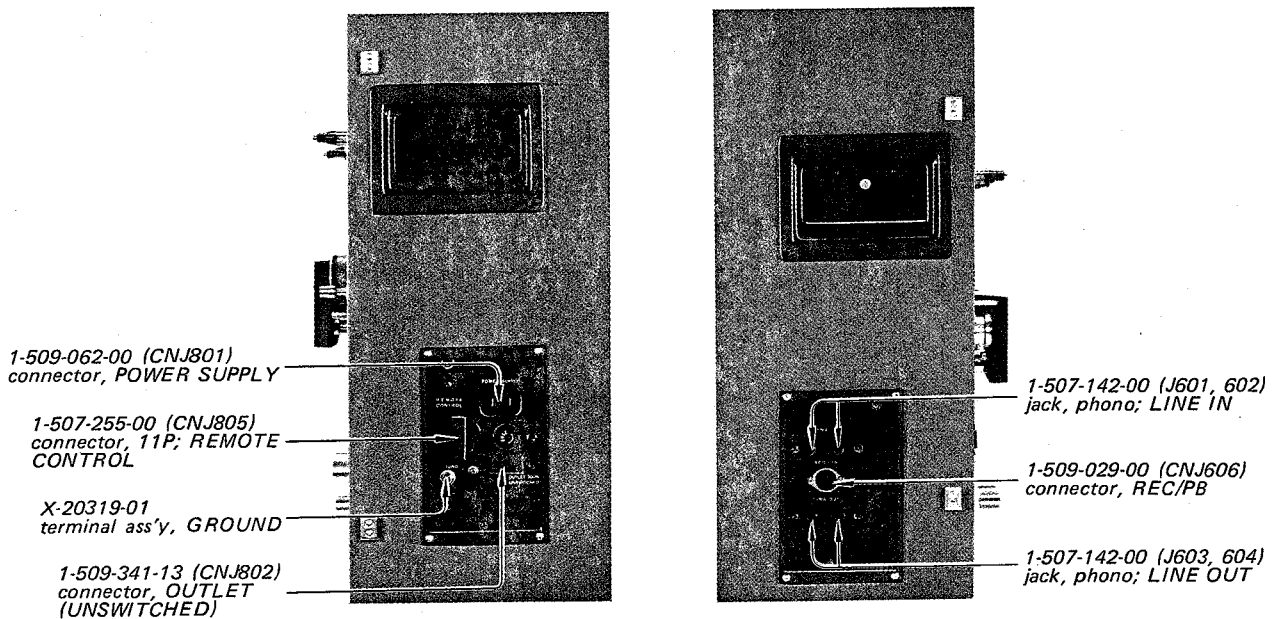

Chassis — Top View —

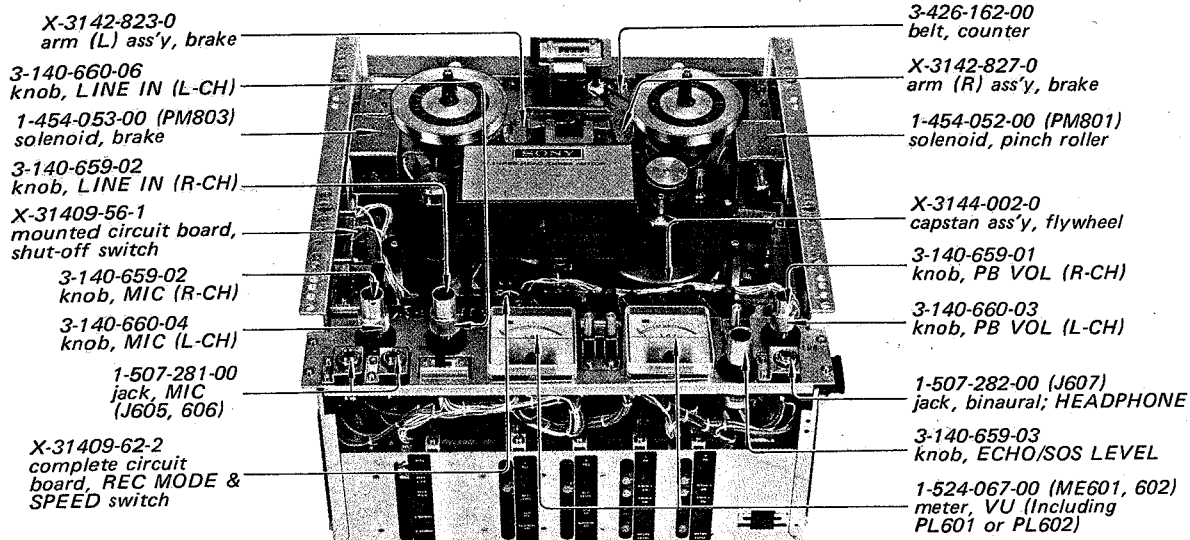

Chassis — Bottom View —

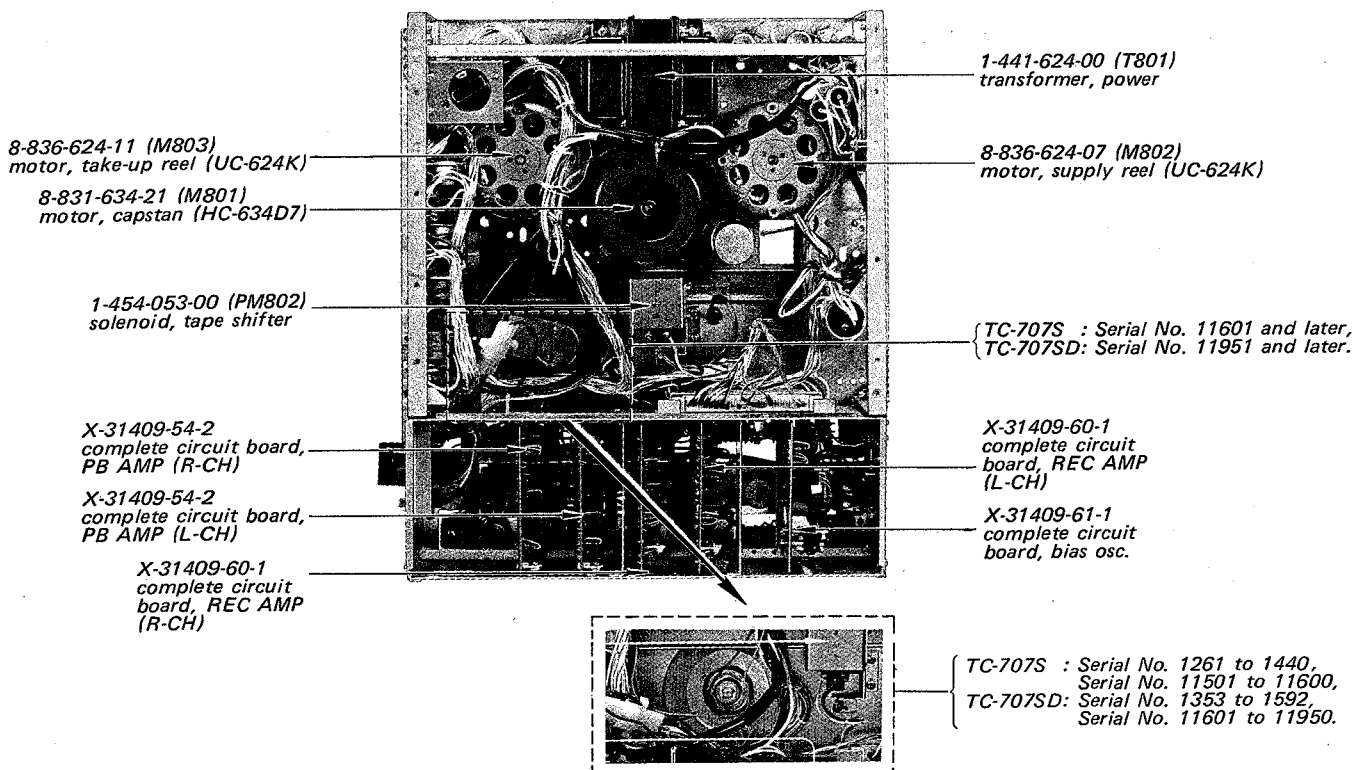

SECTION 2 DISASSEMBLY

2-1. CABINET REMOVAL

TC-707SD

Remove the reel panel by loosening these four screws.

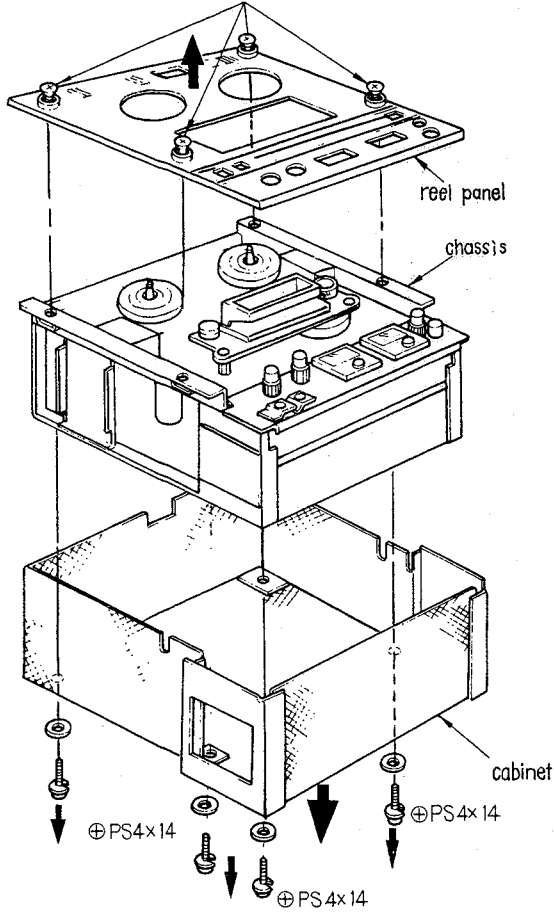

Fig. 2-1.

TC-707S

Remove the reel panel by loosening these four screws.

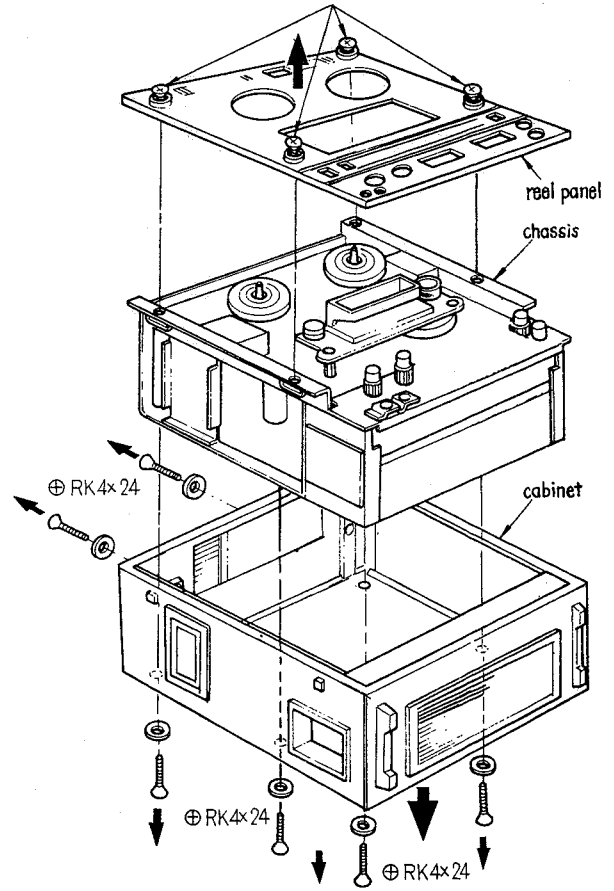

Fig. 2-2.

SECTION 3 ADJUSTMENT PROCEDURES

3-1. MECHANICAL ADJUSTMENT

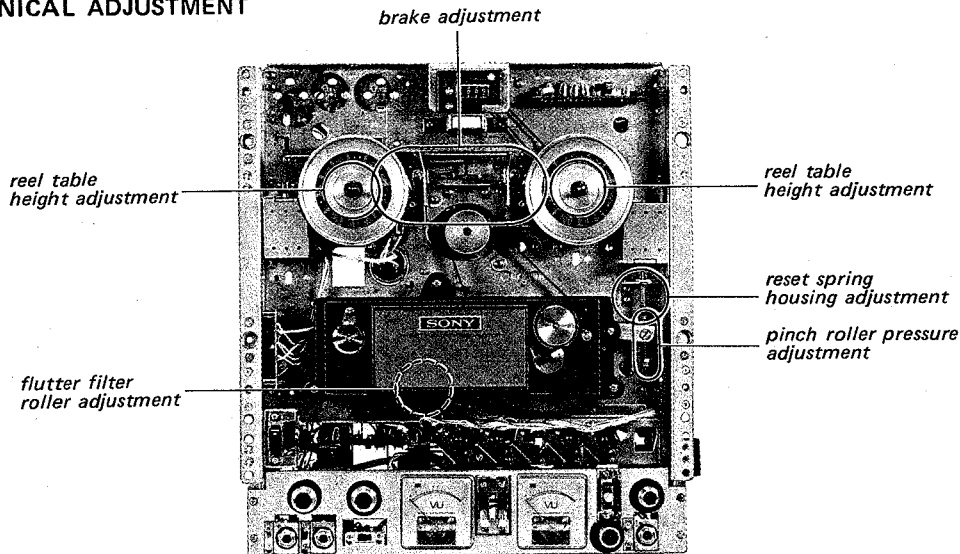

Fig. 3-1-1. Adjusting parts location

3-1-1. Reset Spring Housing Adjustment

See Fig. 3-1-2.

Steps:

- (1) Remove the Reel Panel. See "Cabinet Removal" in page 6.
- (2) Thread a tape.
- (3) Check for approx. 1 mm ($\frac{3}{64}$ ") clearance between the tape and the Pinch Roller in the fast forward and the rewind mode. If necessary, loosen the two screws marked ▲ in Fig. 3-1-2, and adjust the position of the Reset Spring Housing by moving in the directions shown by the arrows.
- (4) After the adjustment, apply lock paint to the adjusting screws.

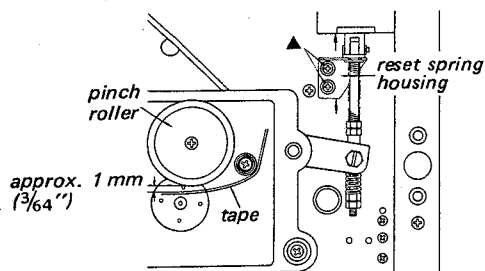

Fig. 3-1-2. Reset spring housing adjustment

Steps:

- (1) Remove the Head Cover.
- (2) Thread a tape and set the unit to the play mode.
- (3) Adjust the height of the Flutter Filter Roller by the screws marked ▲ and ● in Fig. 3-1-3 so that the tape runs through the middle of the Flutter Filter Roller.
- (4) Turn the screw marked ● in Fig. 3-1-3 to perform the azimuth adjustment of the Flutter Filter Roller.
- (5) For zenith adjustment turn the two screws marked ▲ in Fig. 3-1-3 to contact the tape uniformly with the record and playback heads.
- (6) Make sure that the Flutter Filter Roller smoothly rotates during tape running. Apply lock paint to the adjusting screws.

3-1-2. Flutter Filter Roller Adjustment

See Fig. 3-1-3.

Note: No adjustment required for :
 TC-707S Serial No. 11,601 and later.
 TC707SD..... Serial No. 11,951 and later.

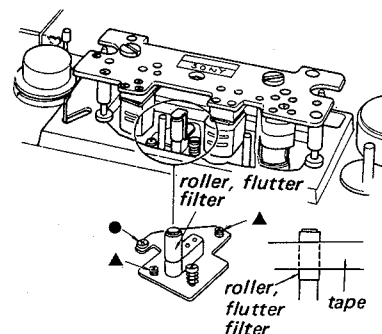

Fig. 3-1-3. Flutter filter roller adjustment

3-1-3. Pinch Roller Pressure Adjustment

See Fig. 3-1-4 and 3-1-5. This adjustment should be made after the Reset Spring Housing Adjustment.

Steps:

- (1) Remove the Reel Panel.
- (2) Set the unit to the play mode.
- (3) Adjust the adjusting nut (A) for 1 mm ($\frac{3}{64}$ "") clearance between the Link Shaft and the adjusting nut (A). See Fig. 3-1-4.
- (4) Make a loop with a piece of string and attach the spring scale to the Pinch Roller Shaft with the loop of string. See Fig. 3-1-5. Pull the scale horizontally in the direction shown by the arrow. The Capstan Shaft, Pinch Roller and the spring scale should be in a line. Check the reading when the Pinch Roller just leaves the Capstan Shaft.
- (5) Adjust the adjusting nut (B) for 1.7 ± 0.1 kg (3 lb 8 oz to 3 lb 15 oz)
- (6) Repeat steps 3 to 5 several times.
- (7) After adjustment lock the adjusting nut (B) by the lock nut (B), and the adjusting nut (A) by the lock nut (A). (Be careful not to move the adjusting nuts.)

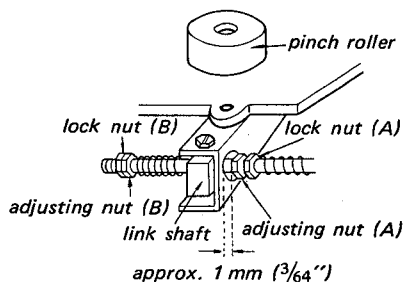

Fig. 3-1-4. Pinch roller pressure adjustment (1)

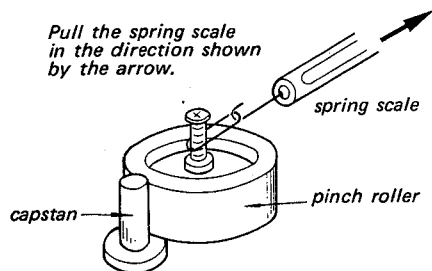

Fig. 3-1-5. Pinch roller pressure adjustment (2)

- (8) Make sure that the unit operates normally when a mode is changed from the play to the stop and vice versa several times. If the tape slips, readjust the above steps.

3-1-4. Reel Table Height Adjustment

Steps:

- (1) Remove the Reel Panel.
- (2) Place a 7-inch reel onto the Reel Table, and thread a tape.
- (3) Set the unit to the play mode.
- (4) Check both reels to see that tape does not touch either flange of the reels. If the tape is not taken up on the mid portion between the upper and the lower flanges of the reel, loosen the set screws with an allen wrench (hexagon socket), and adjust the reel table height.
- (5) Check for the reel table height in the rewind mode.
- (6) Exchange the reels. Check for the reel table height.
- (7) After the adjustment, apply lock paint to the adjusting screws.

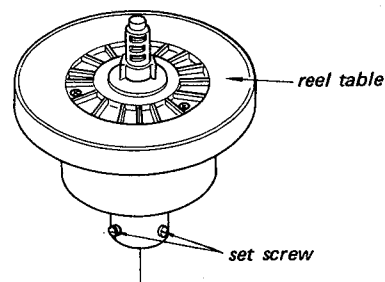

Fig. 3-1-6. Reel table height adjustment

3-1-5. Brake Torque Adjustment

— In stop Mode —

1. Make sure that the brake torque is as specified. Specifications:

Take-up Reel	Supply Reel	Brake Torque
clockwise	counter-clockwise	1~1.3 kg·cm (14~18 oz·inch)
counter-clockwise	clockwise	350~450 g·cm (5~6.2 oz·inch)

2. If necessary, change the hooking position of the spring for the specified brake torque. See Fig. 3-1-7.

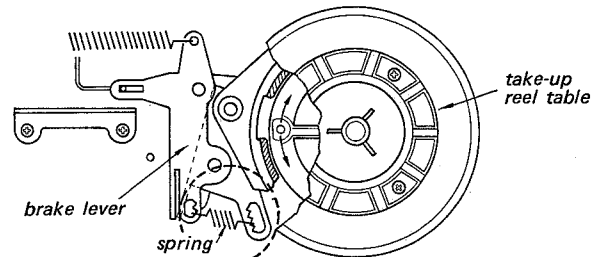

Fig. 3-1-7. Brake torque adjustment

3-1-6. Brake Adjustment

— In STOP Mode —

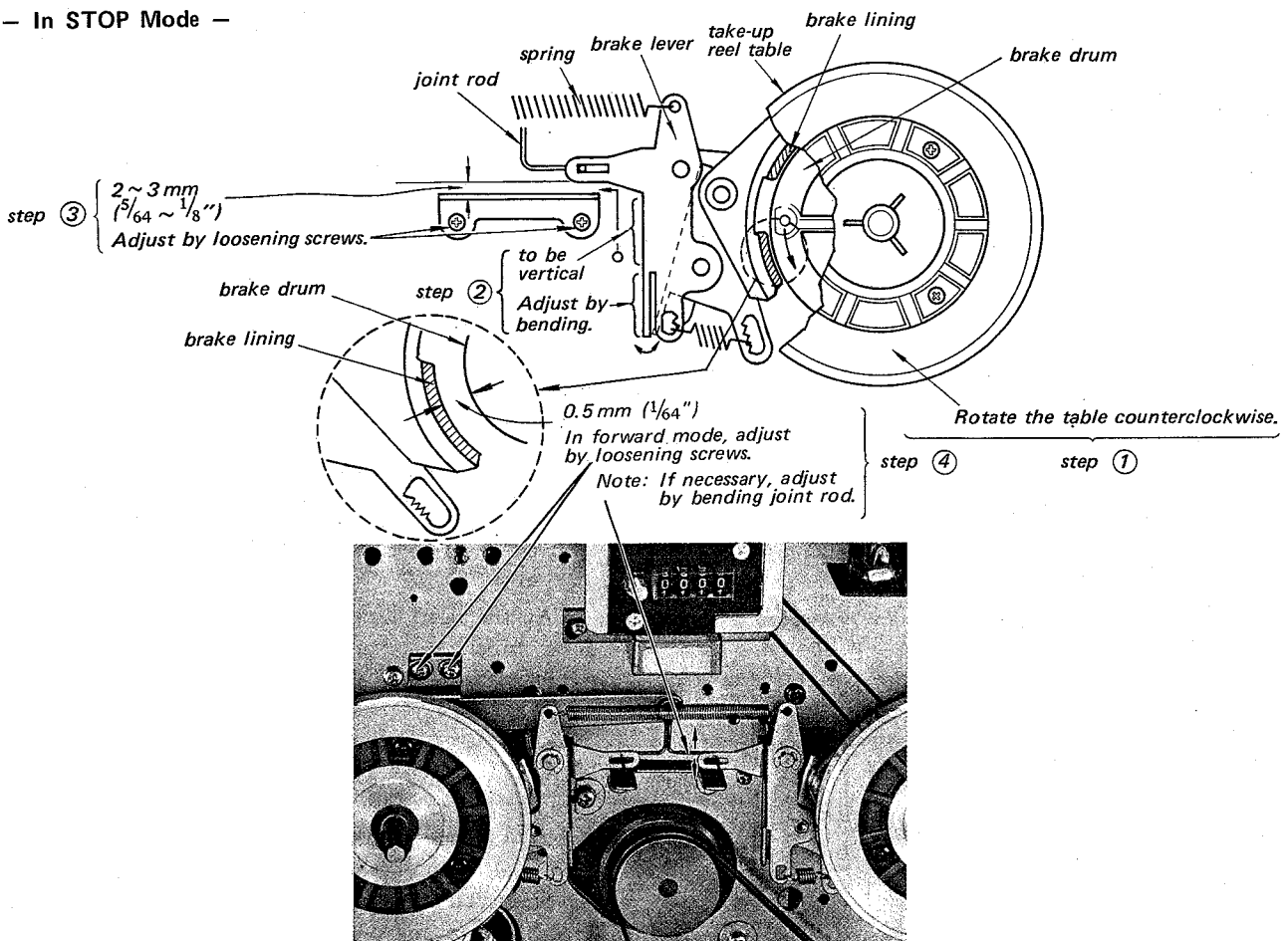

Fig. 3-1-8. Brake adjustment

3-1-7. Reel Motor Torque Adjustment

Set the tape speed to $7\frac{1}{2}$ ips (19 cm/s).

1. Take-Up Motor Torque Adjustment

Steps:

- (1) Place the reel with string wound several turns clockwise on the hub (44 mm dia) onto the Take-up Reel Table. Tie the string to the spring scale.

- (2) Set the unit to the play mode. Pull the spring scale and then allow to take up the string on the reel while approaching the scale to the reel at the same speed of tape running. Adjust R803 by sliding the band for 260 to 280 g-cm (3.6 to 3.9 oz-inch) on the spring scale. See Fig. 3-1-9.

Note: Read the scale while moving it.

2. Back Tension Torque Adjustment

Steps:

- (1) Place the empty hub with string wound several turns counterclockwise on the hub (44 mm dia) onto the Supply Reel Table. Tie the string to the spring scale.
- (2) Set the unit to the play mode. Pull the spring scale at the same speed of tape running. Adjust R802 by sliding the band for 240 to 280 g-cm (3.3 to 3.9 oz-inch) on the spring scale. See Fig. 3-1-9.

Note: Read the scale while pulling it.

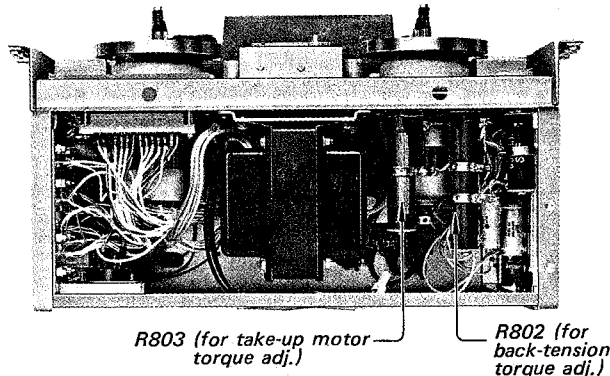

Fig. 3-1-9. Adjusting parts location for reel motor torque adjustment

3-2. MAINTENANCE

3-2-1. Lubrication

Use light machine oil and lubricate the pinch roller shaft and capstan drive motor lubricating hole. Avoid excessive lubrication. It will cause slippage of the mechanism. If the oil should spill on the pinch roller or the rubber belt, wipe it off immediately with denatured alcohol. To lubricate them, proceed as follows:

- (1) Remove the head cover and the screw securing pinch roller and then lubricate the pinch roller shaft with one drop of light machine oil.
- (2) Remove the reel panel and lubricate the motor lubricating hole with several drops of light machine oil.

Note: Use the oil whose viscosity is comparatively heavy at the pinch roller shaft.

TC-707S : Serial No. 1261 to 1440, Serial No. 11501 to 11600.
TC-707SD : Serial No. 1353 to 1592, Serial No. 11601 to 11950.

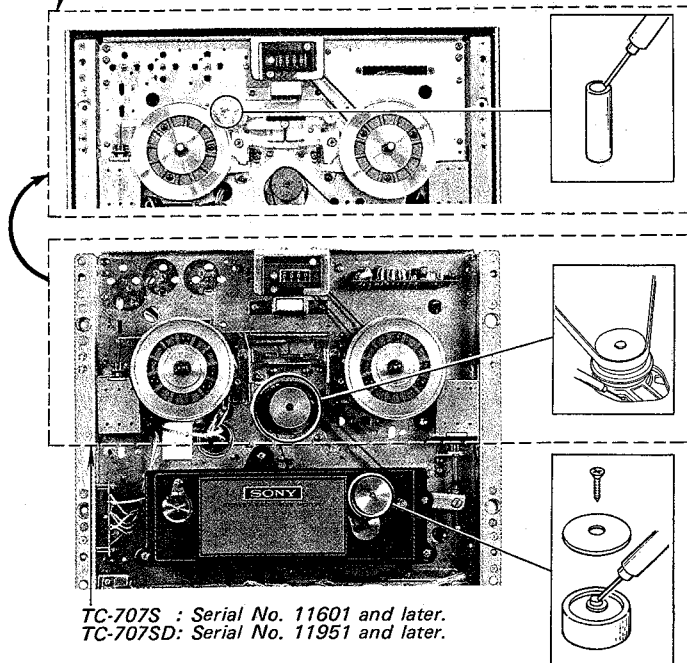

TC-707S : Serial No. 11601 and later.
TC-707SD : Serial No. 11951 and later.

Fig. 3-2-1. Lubrication

3-2-2. Cleaning

Dusts and dirt which were brought by tape may stick to the core of the record, playback or erase head, and they may deteriorate the performance of the playback head. So wipe off the surface of head which contacts tape, with a clean and soft cloth dampened with denatured alcohol. To insure proper operation, the heads should be cleaned at least once during each ten hours of actual operation.

CAUTION

Do not use any other solvent on the head as some will damage the material which binds the head laminations together. Also do not use any metallic device which will scratch the head.

At the same time, clean capstan, rubber belt, pinch roller, tape guide, flutter filter roller and stabilizing shaft.

3-2-3. Demagnetizing

The record and playback heads may occasionally acquire a degree of permanent magnetization, which will result in an increase of noise level, distortion of any recorded signal, and a gradual erasure of high frequency on any recorded tape which passed over them. These heads may be easily demagnetized with a SONY head demagnetizer HE-2 (optional accessory) or equivalent.

To demagnetize the heads, proceed as follows:
Steps:

- (1) Remove the head cover.
- (2) Make sure that power switch on the TC-707S/SD is in the OFF position.
- (3) Connect the demagnetizer to ac power source.
- (4) Bring the tips of the demagnetizer in close proximity to, but not in contact with, the heads so that the tips straddle the gap in the center of the head, run the tips up and down

the heads several times, and then slowly withdraw the demagnetizer.

CAUTION

Do not bring magnet close to heads.

3-3. ELECTRICAL ADJUSTMENT

Precaution:

Before making the adjustment, read the following carefully.

- (1) Set the PB VOL control to the position where the VTVM indicates 0 dB (0.775 V) when playing back the first tone (400 Hz, 0 dB) of SONY alignment tape J-19-F₂, except the dummy coil and the bias trap coil adjustments.
- (2) Set the switches to the position indicated below, unless otherwise specified.

TAPE SPEED switch 19 cm/s (7½ ips)
 SOS & ECHO switch OFF
 MONITOR switch TAPE
 TAPE SELECTOR switch NORMAL

- (3) Clean the heads with soft cloth dampened with denatured alcohol and also demagnetize them with a demagnetizer.
- (4) A new tape or a sufficiently-demagnetized tape should be used as a blank test tape.
- (5) The test equipments needed for the adjustment are as follows:

- Audio oscillator
- Attenuator
- 600Ω and 100 kΩ resistors
- VTVM
- Non-magnetic screwdriver
- SONY alignment tapes, J-19-F₂ and J-9-F₁
- Blank tape
- SONY SLH blank tape

- (6) Connect the VTVM and the 100 kΩ resistor in parallel with LINE OUT jack, except the dummy coil adjustment.
- (7) SONY alignment tapes contain the following information in the sequence indicated.

tone tape	1st	2nd	3rd	4th	5th	6th	7th
J-19-F ₂	400 Hz 0 dB	400 Hz -10 dB	10 kHz -10 dB	12.5 kHz -10 dB	7 kHz -10 dB	80 Hz -10 dB	40 Hz -10 dB
J-9-F ₁	5 kHz -10 dB	400 Hz 0 dB	400 Hz -10 dB	5 kHz -10 dB	3 kHz -10 dB	200 Hz -10 dB	80 Hz -10 dB

- (8) Reference numbers in the parentheses are applied to R-CH adjustment.

3-3-1. Playback and Record Head Azimuth Adjustment

Settings:

TAPE SPEED switch: 7½ ips (19 cm/s)

Procedure:

1. Mode: playback
 P-4-A81
 (6.3 kHz, -10 dB)

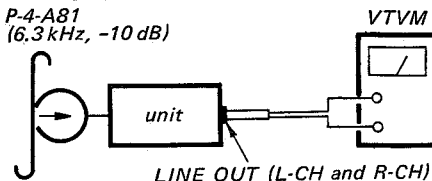

	Applicable Serial No.	Remarks
TC-707S	Serial No. 1,261 to 1,440 Serial No. 11,501 to 11,600	Adjust alternately screws A and B for maximum reading on the VTVM. (See Fig. 3-3-1.)
	Serial No. 11,601 and later	Adjust screw for maximum reading on the VTVM. (See Fig. 3-3-2.)
TC-707SD	Serial No. 1,261 to 1,440 Serial No. 11,601 to 11,950	Adjust alternately 3-3-2 screws A and B for maximum reading on the VTVM. (See Fig. 3-3-1.)
	Serial No. 11,951 and later	Adjust screw for maximum reading on the VTVM. (See Fig. 3-3-2.)

2. After completing the adjustment, apply lock paint to the screw.

Adjustment Location:

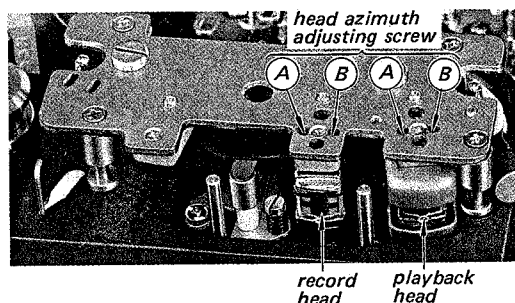

Fig. 3-3-1. Adjusting parts location (1)

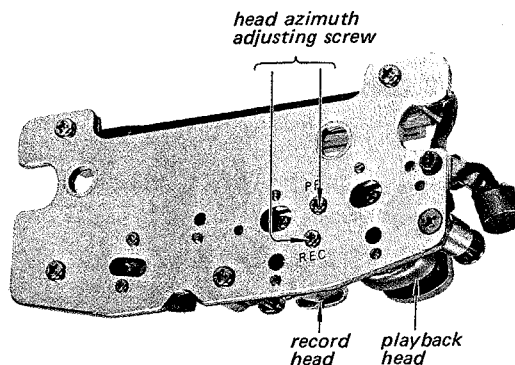

Fig. 3-3-2. Adjusting parts location (2)

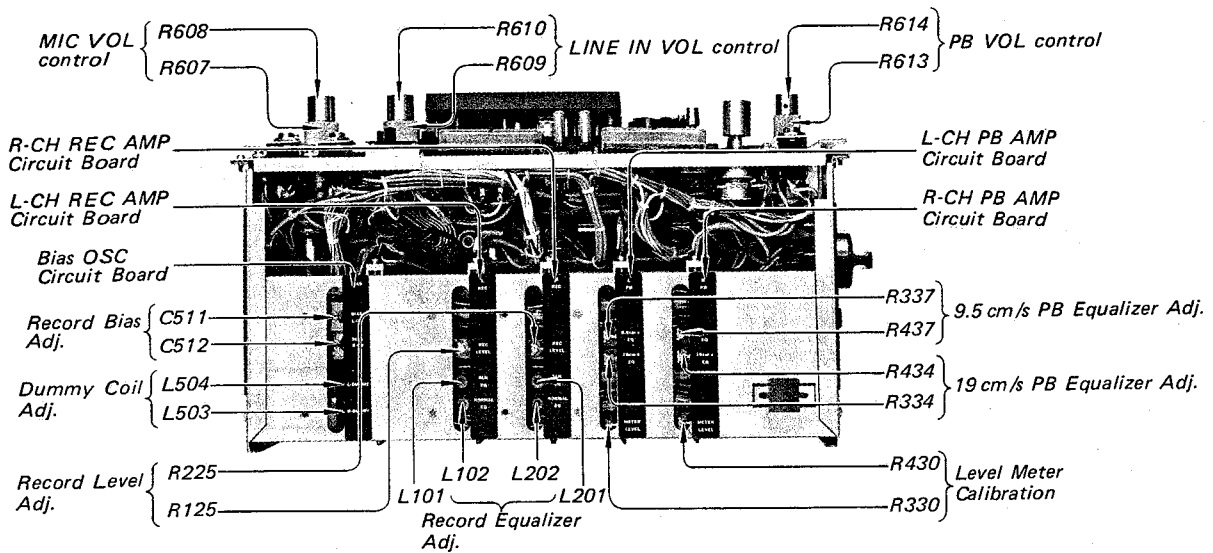

Fig. 3-3-3. Adjusting parts locations

3-3-2. Level Meter Calibration

Steps:

- (1) Place the unit in FWD mode.
- (2) Set the PB VOL control to the position indicated in the Precaution on page 11.
- (3) Play back the first tone (400 Hz, 0 dB) of SONY alignment tape J-19-F2.
- (4) Adjust R330 (R430) so that the level meter indicates 0 VU.

- (3) Be sure that the VTVM indicates -10 dB (0.24 V).
- (4) Play back the third tone (10 kHz, -10 dB) and the fourth tone (12.5 kHz, -10 dB) of SONY alignment tape J-19-F2.
- (5) Adjust R334 (R434) so that the VTVM indicates -10 dB (0.24 V) against each frequency.
- (6) Change the TAPE SPEED switch to 9.5 cm/s (3¾ ips).
- (7) Play back the third tone (400 Hz, -10 dB) of SONY alignment tape J-9-F1.
- (8) Be sure that the VTVM indicates -10 dB (0.24 V).
- (9) Play back the fourth tone (5 kHz, -10 dB) of SONY alignment tape J-9-F1.
- (10) Adjust R337 (R437) so that the VTVM indicates -10 dB (0.24 V).

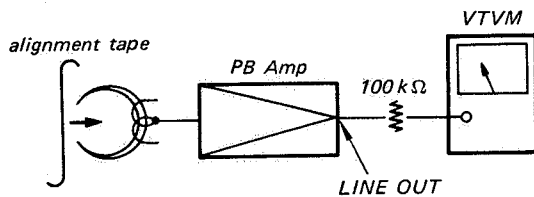

Fig. 3-3-4. Level meter calibration setup

3-3-3. PB Equalizer Adjustment

Steps:

- (1) Set the TAPE SPEED switch to 19 cm/s (7½ ips).
- (2) Play back the second tone (400 Hz, -10 dB) of the SONY alignment tape J-19-F2.

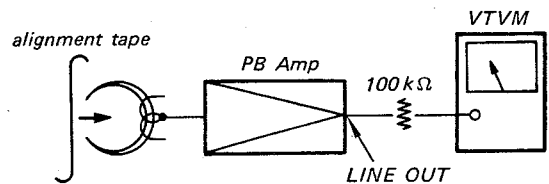

Fig. 3-3-5. PB equalizer adjustment setup

3-3-4. Dummy Coil Adjustment

Steps:

- (1) Pull out the head cover upwards.
- (2) Connect the VTVM across the terminal No. ③ and ⑤ (No. ④ and ⑤) of the head connector (CNJ804) as shown in Fig. 3-3-6.
- (3) Place the unit in stereo-record mode.
- (4) Memorize the VTVM reading.
- (5) Set L-CH (R-CH) only in record mode.
- (6) Adjust Ls03 (Ls04) so that the VTVM reading across the terminal No. ③ and ⑤ (No. ④ and ⑤) is the same as the value obtained in the step (4).

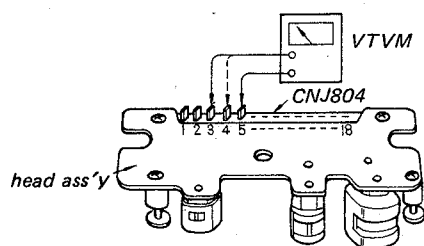

Fig. 3-3-6. Dummy coil adjustment setup

3-3-5. Bias Trap Coil Adjustment

Note: This adjustment is necessary only when the trap coil is replaced.

Turn the core until the head surface of the core is even with the upper edge of the bobbin.

3-3-6. Record Bias Adjustment

Steps:

- (1) Be sure that the dummy coil adjustment has been made.
- (2) Set the PB VOL control to the position indicated in the Precaution on page 11 and thread a blank tape.
- (3) Deliver a 1 kHz signal of -60 dB (0.775 mV) into the MIC jack.
- (4) Set the MONITOR switch to "SOURCE".
- (5) Adjust the MIC volume control so that the VTVM indicates 0 dB (0.775 V).
- (6) Change the MONITOR switch to "TAPE".
- (7) Place the unit in stereo-record mode and record the signal on the blank tape.

- (8) Turn the trimmer capacitor C511 (C512) clockwise to the full and return it several times.
- (9) Turn C511 (C512) clockwise slowly, then the VTVM reading will go up and reaching a maximum, and then falling again. Continue to turn C511 (C512) until the VTVM reads 0.5 dB below the maximum reading.

Note: After this adjustment, be sure to make the record equalizer adjustment.

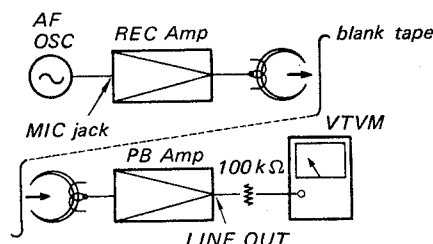

Fig. 3-3-7. Record bias adjustment setup

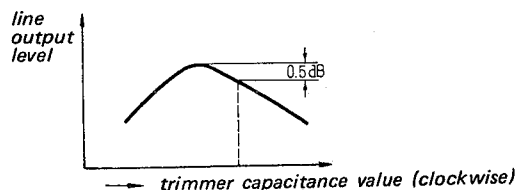

Fig. 3-3-8. Record bias characteristics

3-3-7. Record Level Adjustment

Steps:

- (1) Thread a blank tape.
- (2) Deliver a 1 kHz signal of -60 dB (0.775 mV) into the MIC jack.
- (3) Set the MONITOR switch to "SOURCE".
- (4) Adjust the MIC volume control so that the VTVM indicates 0 dB (0.775 V).
- (5) Change the MONITOR switch to "TAPE".
- (6) Place the unit in stereo-record mode.
- (7) Adjust R125 (R225) so that the VTVM indicates 0 dB (0.775 V).

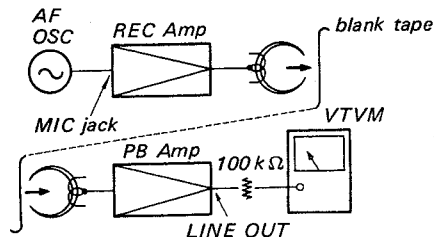

Fig. 3-3-9. Record level adjustment setup

3-3-8. Record Equalizer Adjustment**Steps:**

- (1) Set the TAPE SELECTOR switch to "NORMAL".
- (2) Thread a blank tape.
- (3) Deliver a 1 kHz signal of -20 dB (77.5 mV) into the LINE IN jack.
- (4) Place the unit in stereo-record mode.
- (5) Adjust the LINE IN volume control so that the VTVM indicates -20 dB (77.5 mV).
- (6) Change the signal continuously from 1 kHz to 20 kHz.
- (7) Adjust L₁₀₂ (L₂₀₂) so that the VTVM indicates -20 dB (77.5 mV) everywhere within the range indicated.
- (8) Change the TAPE SELECTOR switch to "SLH".
- (9) Thread the SLH (SONY Low-noise High-output) tape as a blank tape.
- (10) Deliver a 1 kHz signal of -20 dB (77.5 mV) into the LINE IN jack.
- (11) Place the unit in stereo-record mode.
- (12) Adjust the LINE IN volume control so that the VTVM indicates -20 dB (77.5 mV).
- (13) Change the signal continuously from 1 kHz to 20 kHz.
- (14) Adjust L₁₀₁ (L₂₀₁) so that the VTVM indicates -20 dB (77.5 mV) everywhere within the range indicated.

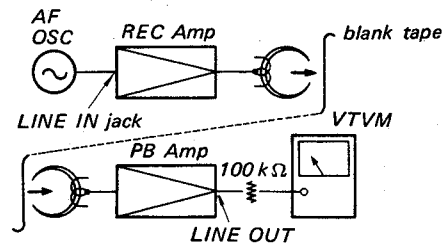
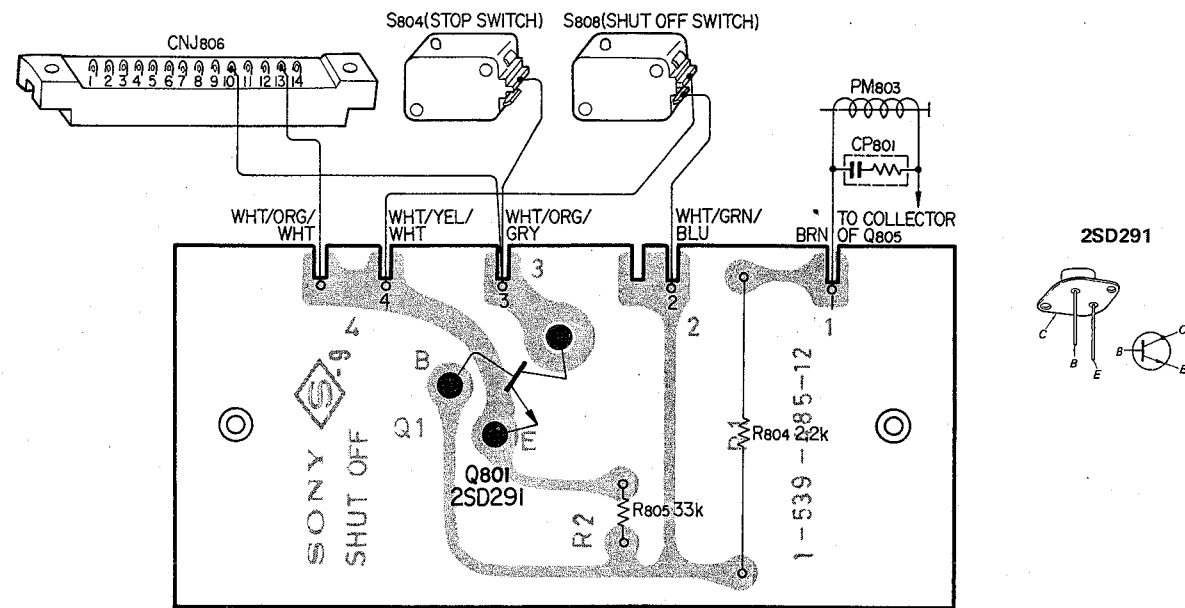

Fig. 3-3-10. Record equalizer adjustment setup

SECTION 4
DIAGRAMS

4-1. SHUT-OFF SWITCH CIRCUIT BOARD

— Conductor Side —



12

4-3. HEAD CONNECTOR CIRCUIT BOARD

— Conductor Side —

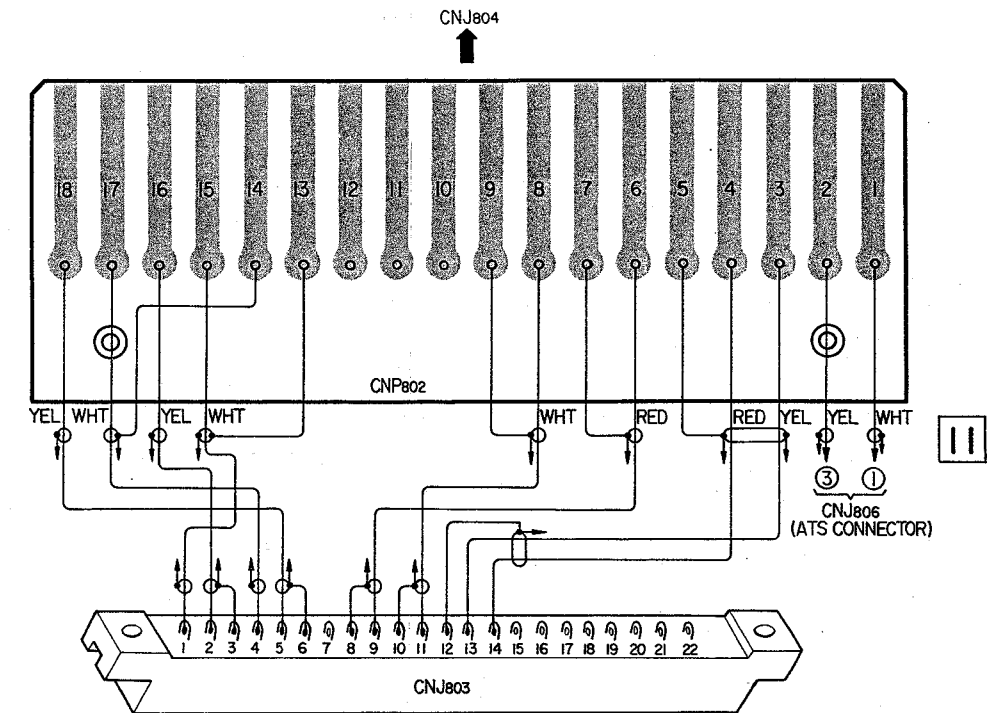

4-2. TAPE SHIFTER SWITCH CIRCUIT BOARD

— Conductor Side —

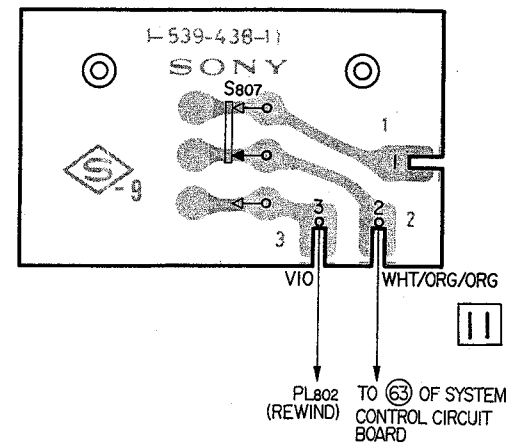

TC-707S/SD TC-707S/SD

4-4. SYSTEM CONTROL CIRCUIT BOARD

- Conductor Side -

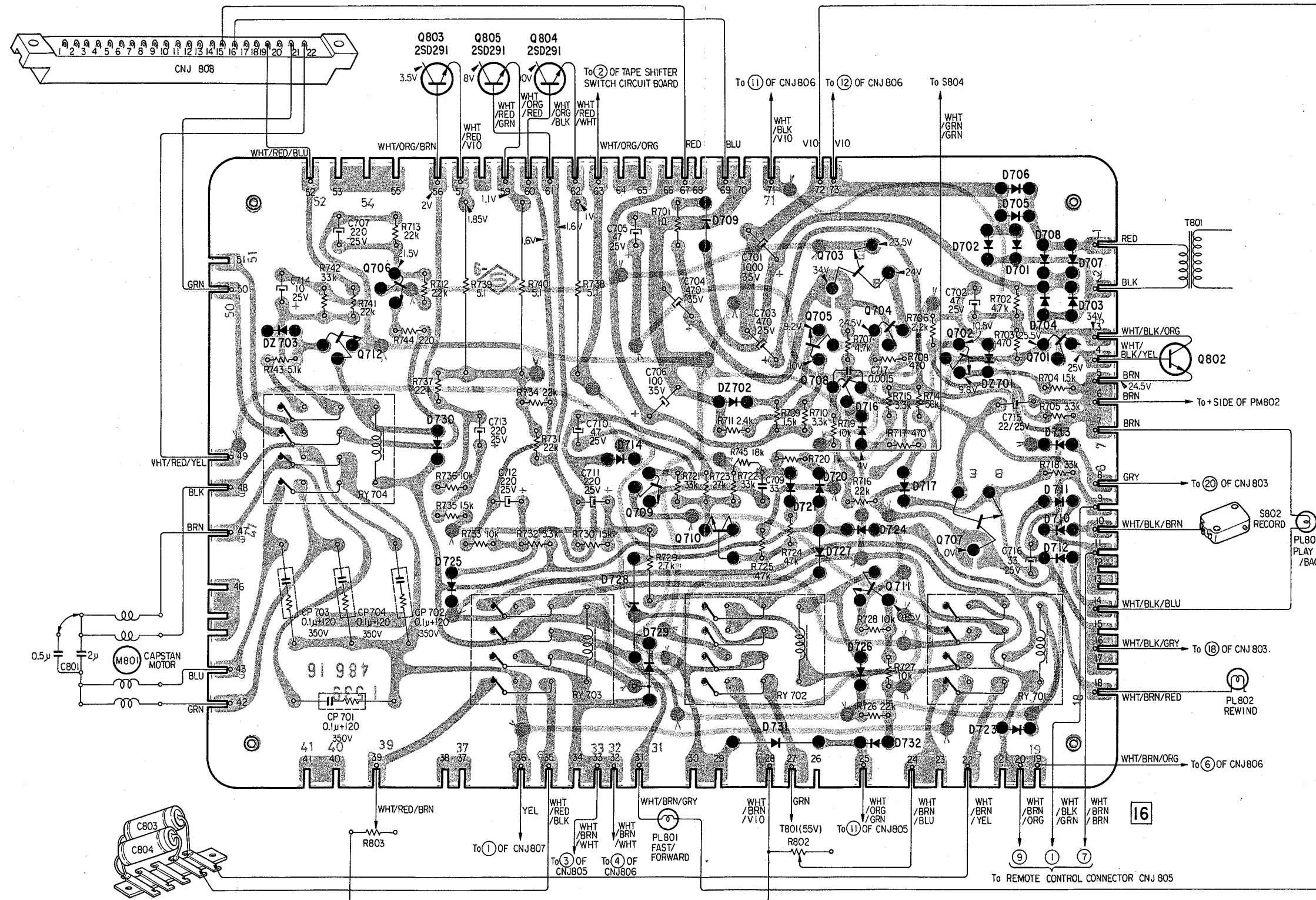

Q701, 702 } 2SC634A
 Q704~706 }
 Q708~712 }

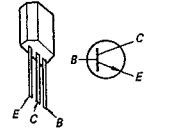

Q703, 707 } 2SD291
 Q803~805 }

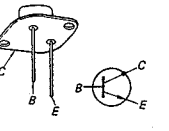

D701~717 } 10D-2
 D720 }
 D722~D732 }

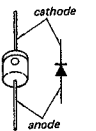

TC-707S/SD TC-707S/SD

4-5. SCHEMATIC DIAGRAM – Systems Control Circuit –
AEP, E model: Serial No. 20, 221 and later

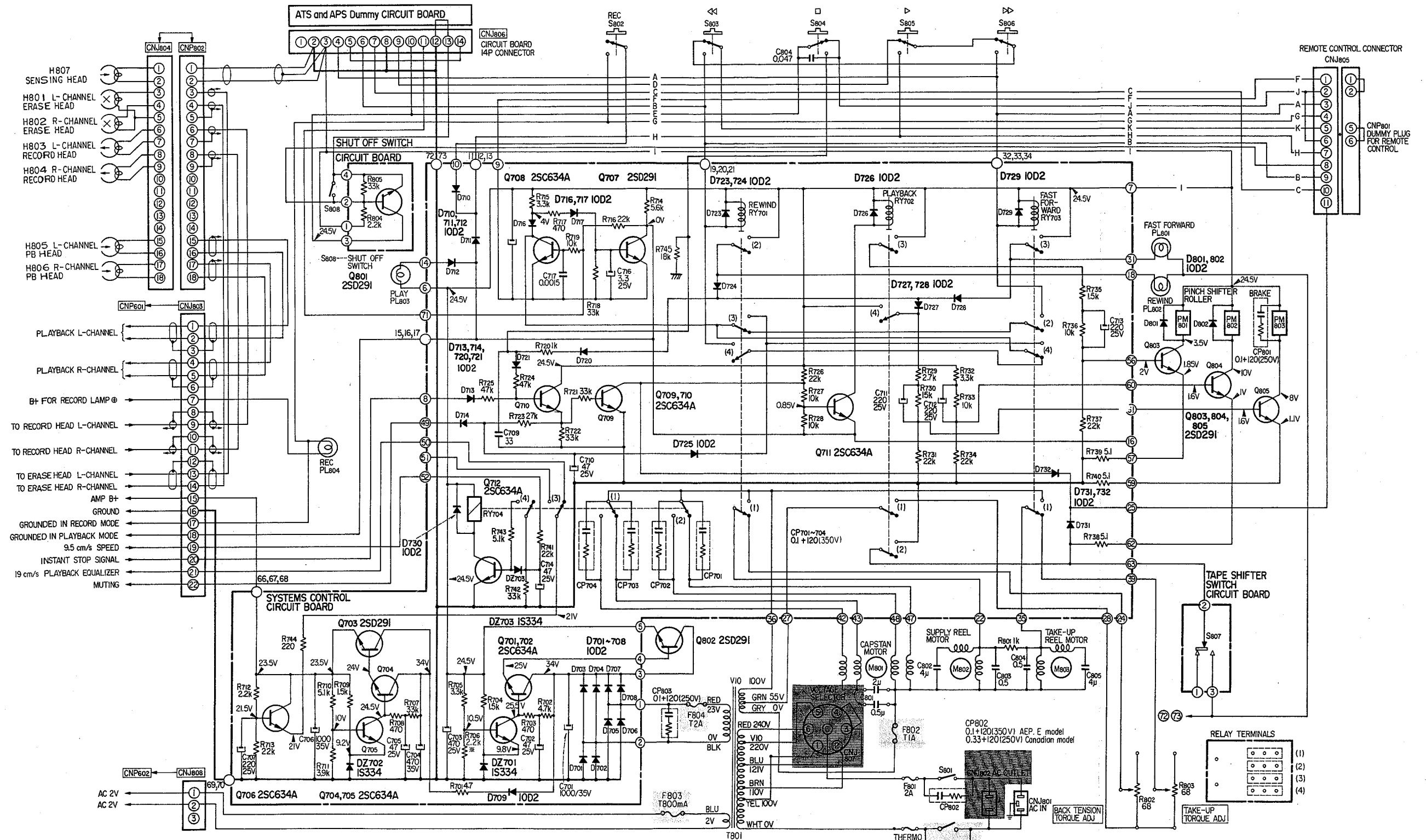

Ref. No.	Switch	Mode
S801	POWER	OFF
S802	REC	OFF
S803	REW	OFF
S804	STOP	ON
S805	PLAY	OFF
S806	FF	OFF
S807	TAPE SHIFT	OFF
S808	SHUT OFF	OFF

Note:

- All resistors and capacitors are rated in Ω and μF unless otherwise specified.
- The letter (B) suffixed to rating value of semi-fixed resistor indicates its characteristic.
- Voltage values shown are measured with a voltmeter (20k Ω/V) with no signal input in record mode.
- * : selected to yield optimum performance.

- : AEP Model only
- : E Model only

4-6. REC AMP CIRCUIT BOARD

- Conductor Side -

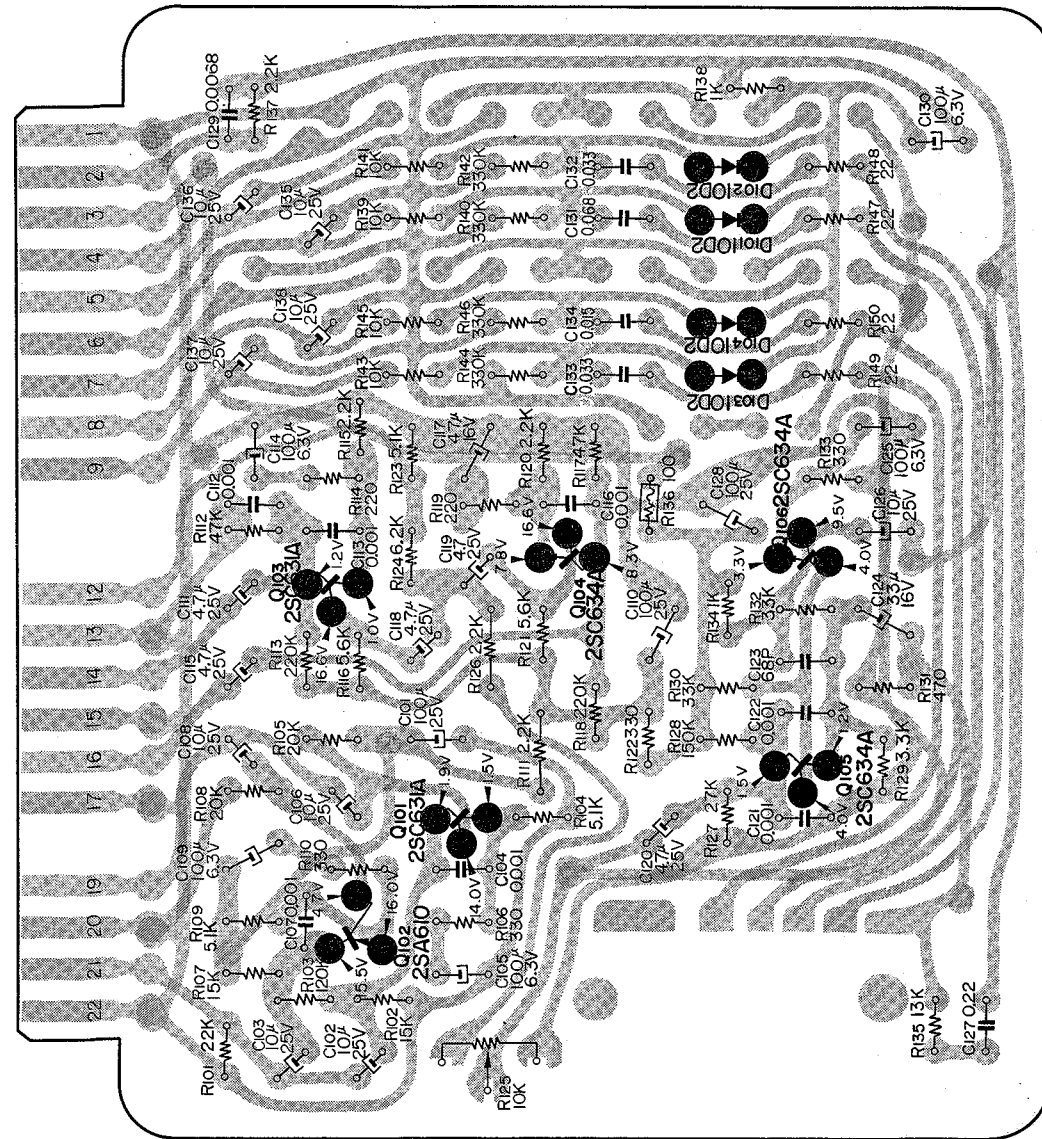

14

4-7. PB AMP CIRCUIT BOARD

- Conductor Side -

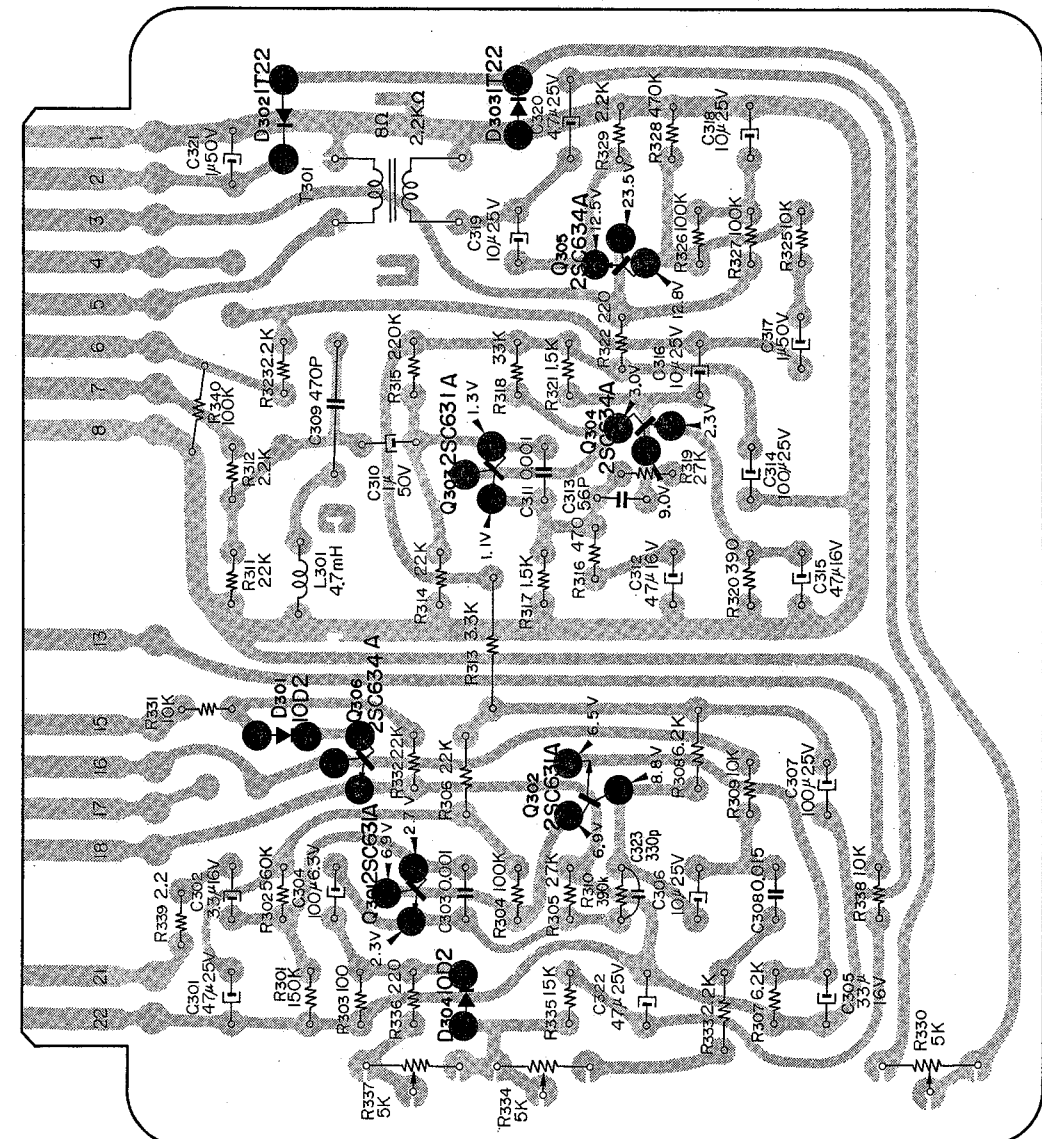

13

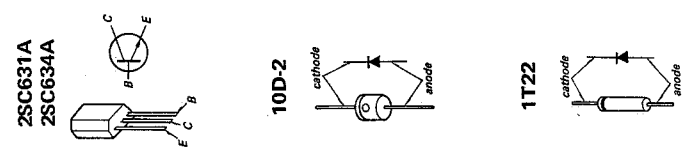
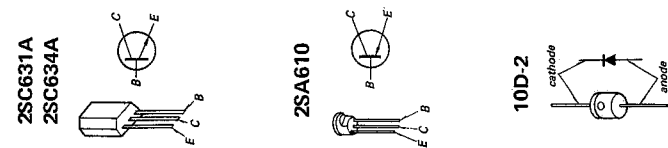

4-8. BIAS OSC CIRCUIT BOARD

— Conductor Side —

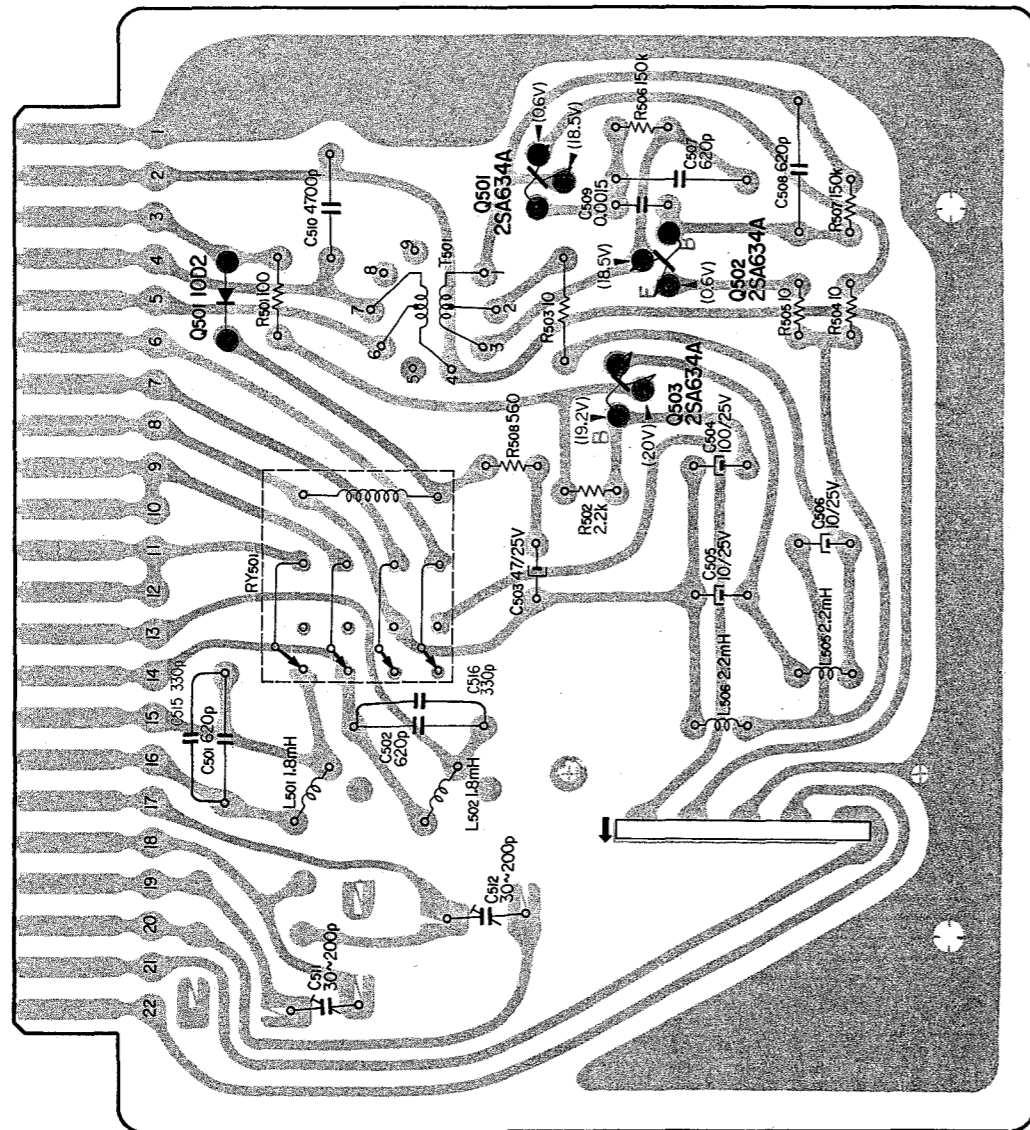
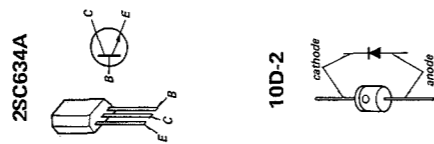

12

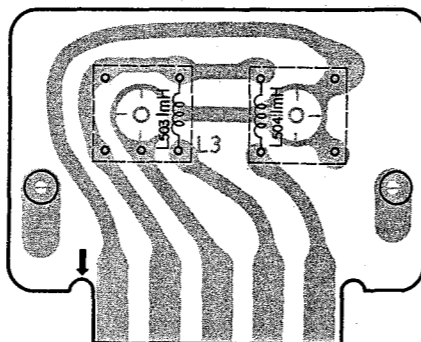

12

4-9. RESISTOR TERMINAL CIRCUIT BOARD

— Conductor Side —

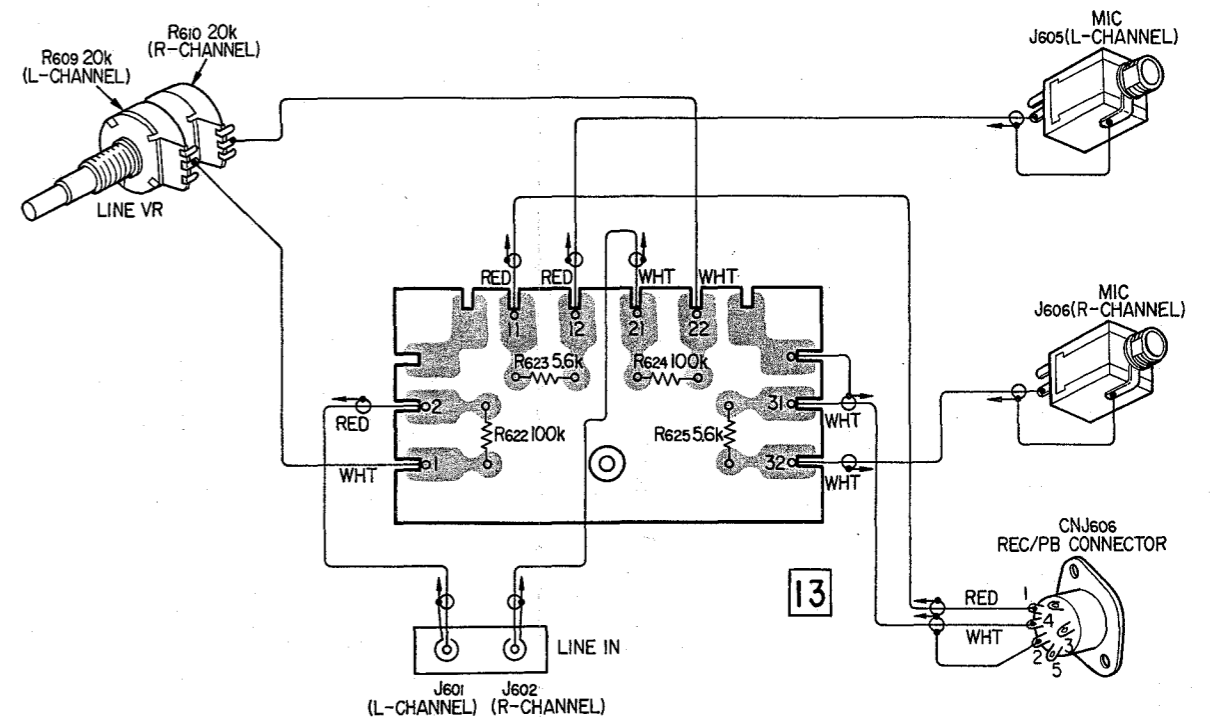

4-10. REC MODE AND SPEED SWITCH CIRCUIT BOARD

— Conductor Side —

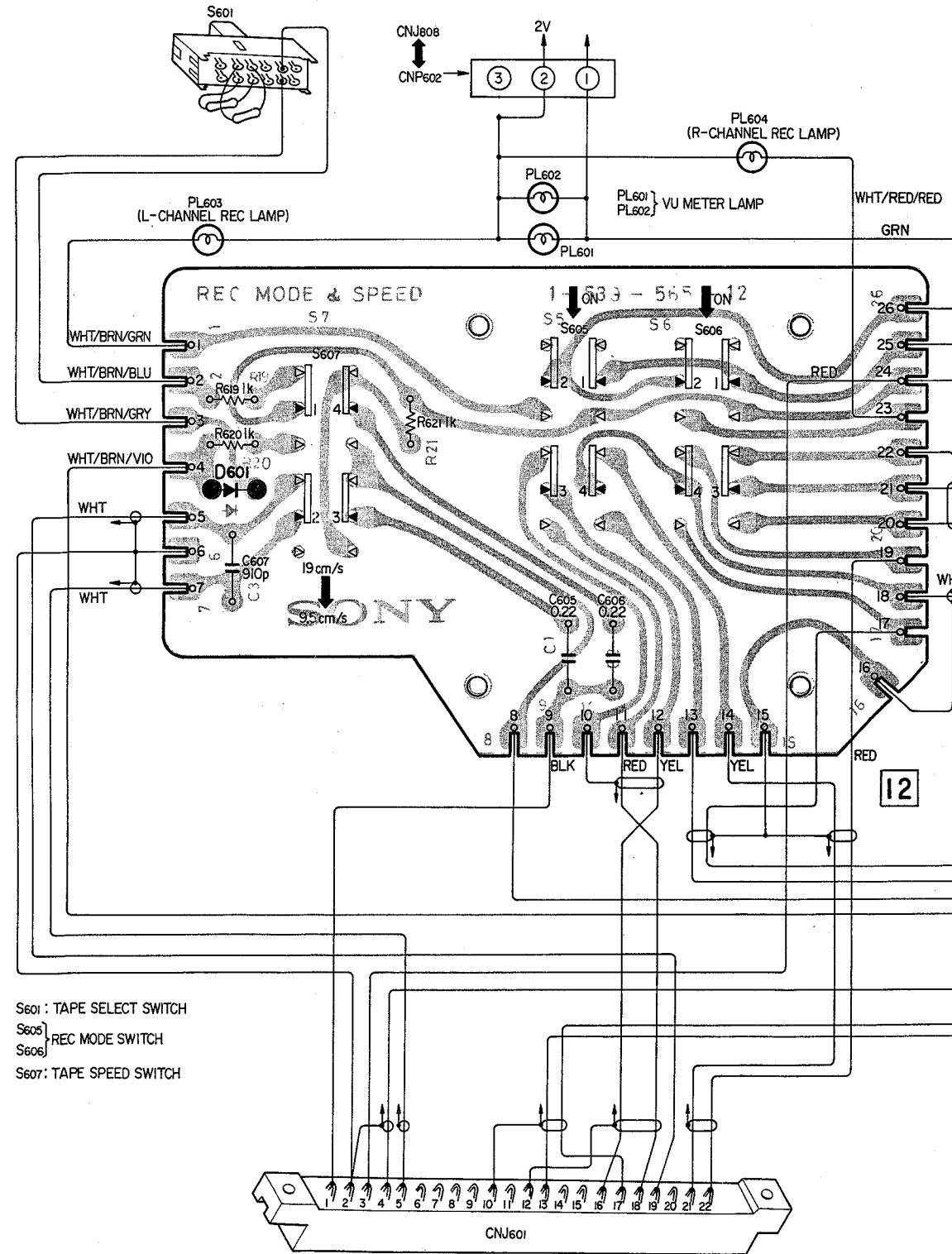

4-11. ECHO/SOS SWITCH CIRCUIT BOARD

— Conductor Side —

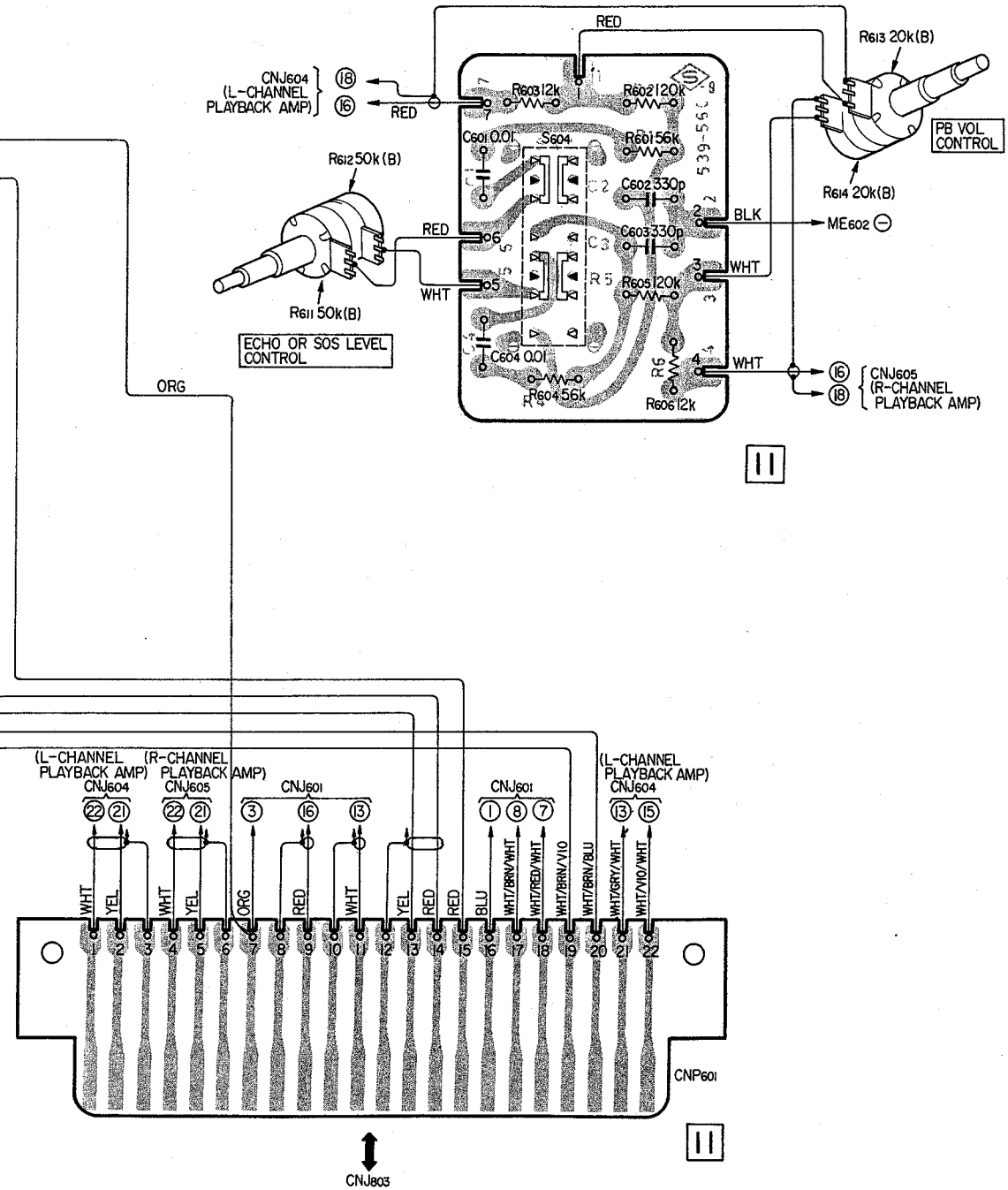

TC-707S/SD TC-707S/SD

4-12. SCHEMATIC DIAGRAM – Audio Amp and Bias Osc Circuit –

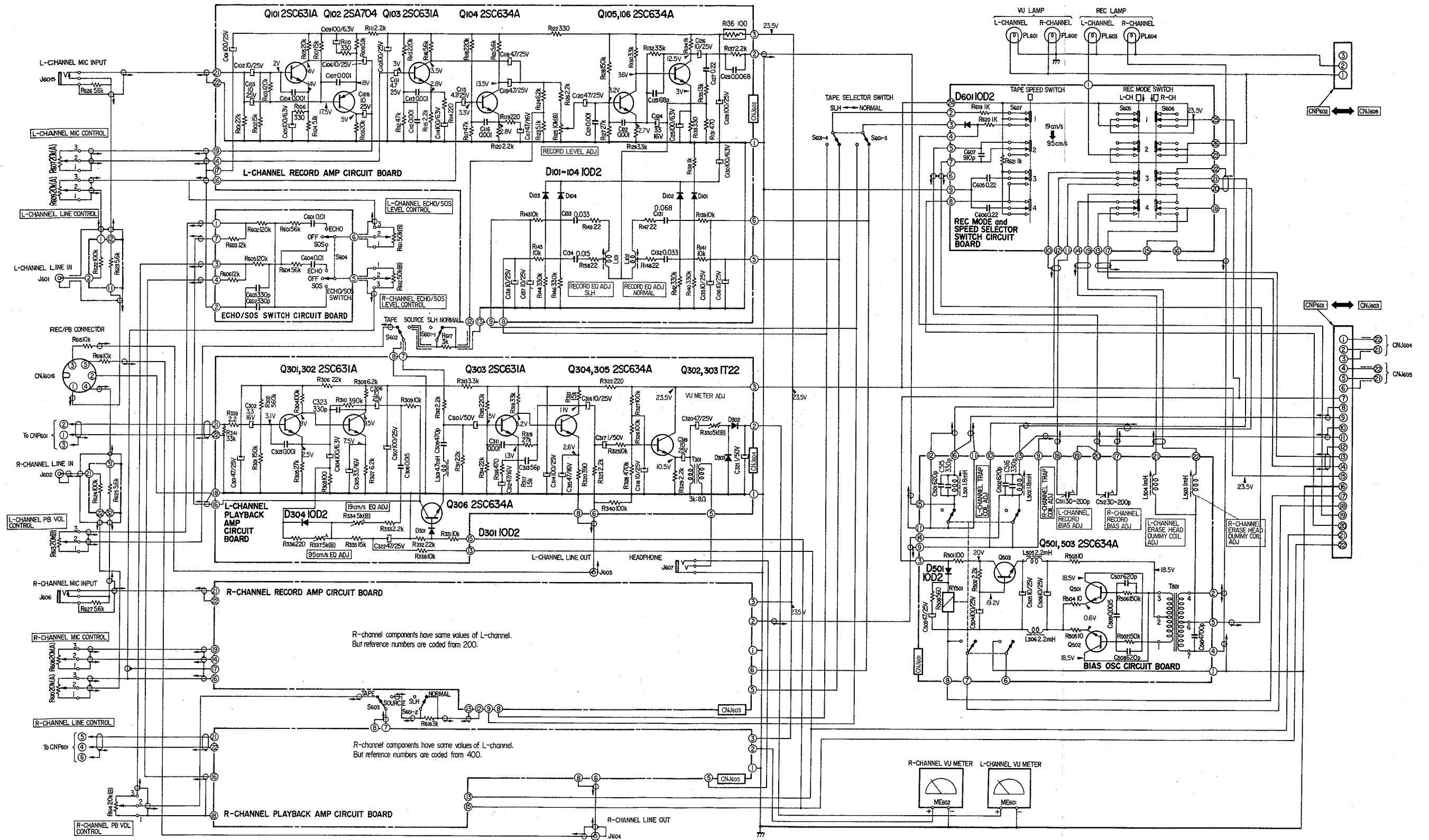

Ref. No.	Switch	Mode
S601	TAPE SELECTOR	NORMAL TAPE
S602	TAPE MONITOR (L-CH)	TAPE
S603	TAPE MONITOR (R-CH)	TAPE
S604	ECHO/SOS	OFF
S605	REC MODE (L-CH)	OFF
S606	REC MODE (R-CH)	OFF
S607	SPEED SELECT	19 cm/s

Note: 1. All resistors and capacitors are rated in Ω and μF unless otherwise specified.
 2. The letter (B) suffixed to rating value of semi-fixed resistor indicates its characteristic.
 3. Voltage values shown are measured with a voltmeter (20 k Ω /V) with no signal input in record mode.

SECTION 5

CONVERSION TO DIFFERENT POWER LINE FREQUENCY

4-13. LEVEL DIAGRAM

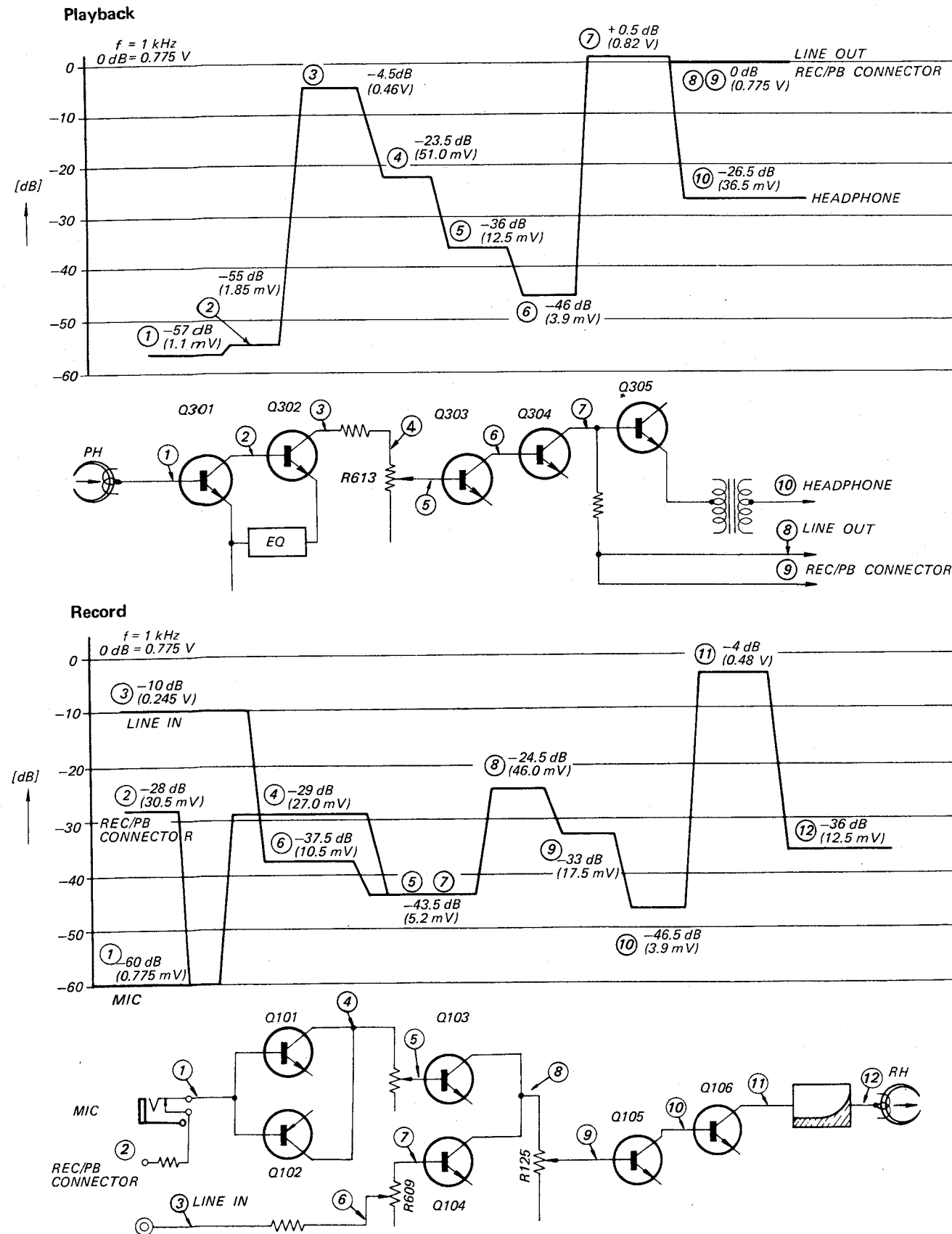

If the deck is to be operated on a line frequency different from the frequency for which the deck is adjusted, proceed as follows:

FIRST:

- (1) Remove the reel panel by removing the four screws (See page 6).
- (2) Loosen the two set screws on the motor pulley with the supplied L-shaped wrench.
- (3) Replace the motor pulley with proper one.

Note: The larger diameter pulley is for 50 Hz and the smaller is for 60 Hz.

SECOND:

- (1) To make the tension of the capstan belt constant, adjust the position of the motor by loosening the screws marked with ▲ and by sliding the motor in the direction shown in Fig. 5-1.

THIRD:

- (1) Change the capacitance of the motor starting capacitor (C801).
For a 50 Hz line frequency, both end taps should be connected by a jumper wire, while for a 60 Hz, these should be left open as shown in Fig. 5-1.

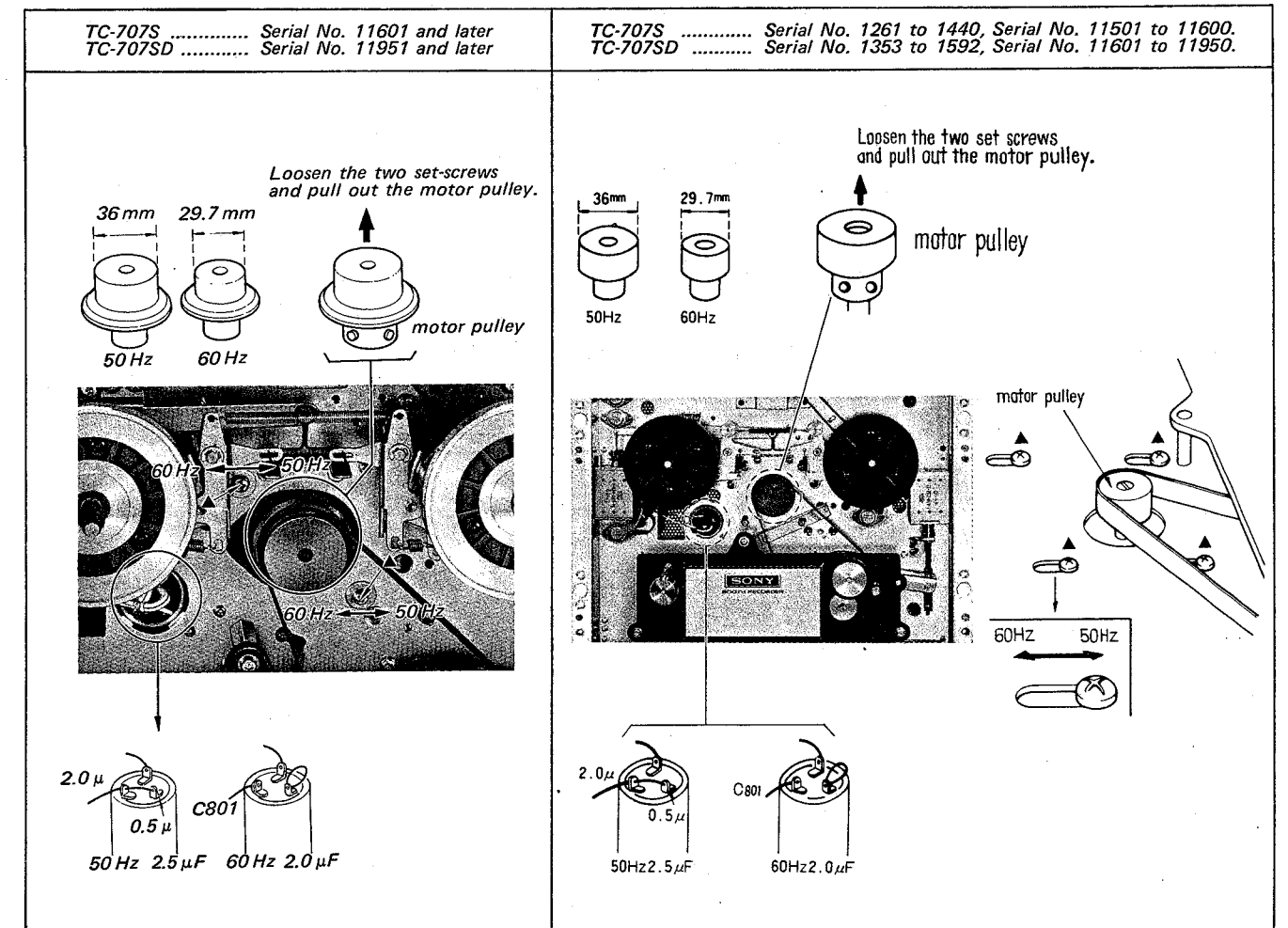

Fig. 5-1. Motor position and adjusting parts Location

**SECTION 6
ELECTRICAL PARTS LIST**

<u>Ref. No.</u>	<u>Part No.</u>	<u>Description</u>	<u>Ref. No.</u>	<u>Part No.</u>	<u>Description</u>
COMPLETE CIRCUIT BOARDS			Q305,405	Transistor	2SC634A
			Q306,406	Transistor	2SC634A
X-31409-54-2	PB AMP		Q501	Transistor	2SC634A
X-31409-56-1	Shut-off Switch		Q502	Transistor	2SC634A
X-31409-59-2	Systems Control		Q503	Transistor	2SC634A
X-31409-60-1	REC AMP		Q701,702	Transistor	2SC634A
X-31409-61-1	Bias Osc		Q703	Transistor	2SD291
X-31409-62-2	REC MODE & SPEED Switch		Q704~706	Transistor	2SC634A
X-31409-63-1	Resistor Terminal		Q707	Transistor	2SD291
X-31409-64-1	Tape Shifter Switch		Q708~712	Transistor	2SC634A
X-31409-65-1	ECHO/SOS Switch		Q801	Transistor	2SD291
PRINTED CIRCUIT BOARDS			Q802	Transistor	2SD291
1-539-431-00	REC AMP		Q803	Transistor	2SD291
1-539-432-00	Sub (Record Amp.)		Q804	Transistor	2SD291
1-539-435-00	Resistor Terminal		Q805	Transistor	2SD291
1-539-436-00	Head Connector		D101,201	Diode	10D2
1-539-437-00	DOCKING, 22 p		D102,202	Diode	10D2
			D103,203	Diode	10D2
1-539-438-11	Tape Shifter Switch		D104,204	Diode	10D2
1-539-444-00	PB AMP		D301,401	Diode	10D2
1-539-485-00	SHUT-OFF Switch		D302,402	Diode	1T22
1-539-486-16	System Control		D303,403	Diode	1T22
1-539-558-00	Bias Osc		D304,404	Diode	10D2
1-539-560-00	ECHO/SOS Switch		D501	Diode	10D2
1-539-563-00	Sub (Bias Osc.)		D601	Diode	10D2
1-539-565-00	REC MODE & SPEED Switch		D701~714	Diode	10D2
1-539-587-00	Dummy, ATS & APS		D715	-----	
1-584-500-00	Fuse (Canadian model, E model only)		D716,717	Diode	10D2
SEMICONDUCTORS			D720	Diode	10D2
Q101,201	Transistor	2SC631A	D722~732	Diode	10D2
Q102,202	Transistor	2SA704	D801	Diode	10D2
Q103,203	Transistor	2SC631A	D802	Diode	10D2
Q104,204	Transistor	2SC634A	DZ701~703	Zener Diode	1S334
Q105,205	Transistor	2SC634A			
Q106,206	Transistor	2SC634A			
Q301,401	Transistor	2SC631A	COILS		
Q302,402	Transistor	2SC631A	L101,201	1-231-069-00	Equalizer; 1.45/1.8 mH
Q303,403	Transistor	2SC634A	L102,202	1-231-069-00	Equalizer; 1.45/1.8 mH
Q304,404	Transistor	2SC634A			

<u>Ref. No.</u>	<u>Part No.</u>	<u>Description</u>
L301,401	1-407-298-00	Trap
L501	1-231-069-00	Equalizer; 1.45/1.8 mH
L502	1-231-069-00	Equalizer; 1.45/1.8 mH
L503,504	1-409-038-00	Dummy, 1 mH
L505,506	1-407-198-00	Microinductor; 2.2 mH

TRANSFORMERS

T301,401	1-427-284-00	Headphone
T501	1-433-145-00	Bias Osc.
T801	1-442-497-00	Power

CAPACITORS

All capacitors are μ F unless otherwise indicated.
(elect = electrolytic, p = μ μ)

C101,201	1-121-416-11	100	25V	elect
C102,202	1-121-398-11	10	25V	elect
C103,203	1-121-398-11	10	25V	elect
C104,204	1-105-661-12	0.001	50V	mylar
C105,205	1-121-413-11	100	6.3V	elect
C106,206	1-121-398-11	10	25V	elect
C107,207	1-105-661-12	0.001	50V	mylar
C108,208	1-121-398-11	10	25V	elect
C109,209	1-121-413-11	100	6.3V	elect
C110,210	1-121-416-11	100	25V	elect
C111,211	1-121-395-11	4.7	25V	elect
C112,212	1-105-661-12	0.001	50V	mylar
C113,213	1-105-661-12	0.001	50V	mylar
C114,214	1-121-413-11	100	6.3V	elect
C115,215	1-121-395-11	4.7	25V	elect
C116,216	1-105-661-12	0.001	50V	mylar
C117,217	1-121-409-11	47	16V	elect
C118,218	1-121-395-11	4.7	25V	elect
C119,219	1-121-395-11	4.7	25V	elect
C120,220	1-121-395-11	4.7	25V	elect
C121,221	1-105-661-12	0.001	50V	mylar
C122,222	1-105-661-12	0.001	50V	mylar

<u>Ref. No.</u>	<u>Part No.</u>	<u>Description</u>
C123,223	1-107-127-11	68p 50V silvered mica
C124,224	1-121-403-11	33 16V elect
C125,225	1-121-413-11	100 6.3V elect
C126,226	1-121-398-11	10 25V elect
C127,227	1-105-689-12	0.22 50V mylar
C128,228	1-121-416-11	100 25V elect
C129,229	1-105-671-12	0.0068 50V mylar
C130,230	1-121-413-11	100 6.3V elect
C131,231		0.068 50V mylar
C132,232		0.033 50V mylar
C133,233		0.033 50V mylar
C134,234		0.015 50V mylar
C135,235	1-121-398-11	10 25V elect
C136,236	1-121-398-11	10 25V elect
C137,237	1-121-398-11	10 25V elect
C138,238	1-121-398-11	10 25V elect
C301,401	1-121-410-11	47 25V elect
C302,402	1-127-304-11	3.3 16V solid aluminum
C303,403	1-105-661-12	0.001 50V mylar
C304,404	1-121-413-11	100 6.3V elect
C305,405	1-121-403-11	33 16V elect
C306,406	1-121-398-11	10 25V elect
C307,407	1-121-416-11	100 25V elect
C308,408	1-105-675-12	0.015 50V mylar
C309,409	1-107-244-11	470p 50V silvered mica
C310,410	1-121-391-11	1 50V elect
C311,411	1-105-661-12	0.001 50V mylar
C312,412	1-121-409-11	47 16V elect
C313,413	1-107-125-11	56p 50V silvered mica
C314,414	1-121-416-11	100 25V elect
C315,415	1-121-409-11	47 16V elect
C316,416	1-121-398-11	10 25V elect
C317,417	1-121-391-11	1 50V elect
C318,418	1-121-398-11	10 25V elect
C319,419	1-121-398-11	10 25V elect
C320,420	1-121-395-11	4.7 25V elect
C321,421	1-121-391-11	1 50V elect
C322,422	1-121-410-11	47 25V elect
C323,423	1-107-143-11	330p 50V silvered mica
C324,424	1-107-131-11	100p 50V silvered mica

<u>Ref. No.</u>	<u>Part No.</u>	<u>Description</u>	
C501	1-107-188-11	620p	500V silvered mica
C502	1-107-188-11	620p	500V silvered mica
C503	1-121-410-11	47	25V elect
C504	1-121-416-11	100	25V elect
C505	1-121-398-11	10	25V elect
C506	1-121-398-11	10	25V elect
C507	1-107-188-11	620p	500V silvered mica
C508	1-107-188-11	620	500V silvered mica
C509	1-105-663-12	0.0015	50V mylar
C510	1-109-507-11	4700	500V dipped mica
C511	1-141-076-11	30~200p	trimmer
C512	1-141-076-11	30~200p	trimmer
C515,516		330p	500V silvered mica
C601	1-105-673-12	0.01	50V mylar
C602	1-103-863-11	330p	50V styrol
C603	1-103-863-11	330p	50V styrol
C604	1-105-673-12	0.01	50V mylar
C605	1-105-689-12	0.22	50V mylar
C606	1-105-689-12	0.22	50V mylar
C607	1-109-501-11	910p	500V dipped mica
C701	1-121-388-11	1000	35V elect
C702	1-121-410-11	47	25V elect
C703	1-121-733-11	470	25V elect
C704	1-121-361-11	470	35V elect
C705	1-121-410-11	47	25V elect
C706	1-121-388-11	1000	35V elect
C707	1-121-422-11	220	25V elect
C708		-----	
C709		33	50V mylar
C710	1-121-410-11	47	25V elect
C711	1-121-422-11	220	25V elect
C712	1-121-422-11	220	25V elect
C713	1-121-422-11	220	25V elect
C714	1-121-398-11	10	25V elect
C715	1-121-480-11	22	25V elect
C716	1-121-392-11	3.3	25V elect
C717	1-105-663-12	0.0015	50V mylar
C801	1-117-040-11	2+0.5	300V metalized paper
C802	1-117-082-11	4	250V metalized paper
C803	1-117-054-11	0.5	350V metalized paper

<u>Ref. No.</u>	<u>Part No.</u>	<u>Description</u>	
C804	1-117-054-11	0.5	350V metalized paper
C805	1-117-082-11	4	250V metalized paper
C806	1-105-681-12	0.047	50V mylar

RESISTORS

All resistors are 1/4W, carbon type and in Ω unless otherwise indicated. (k = 1000)

R101,201	1-242-705-11	22k
R102,202	1-242-701-11	15k
R103,203	1-242-723-11	120k
R104,204	1-242-690-11	5.1k
R105,205	1-242-704-11	20k
R106,206	1-242-661-11	330
R107,207	1-242-701-11	15k
R108,208	1-242-704-11	20k
R109,209	1-242-690-11	5.1k
R110,210	1-242-661-11	330
R111,211	1-242-681-11	2.2k
R112,212	1-242-713-11	47k
R113,213	1-242-729-11	220k
R114,214	1-242-657-11	220
R115,215	1-242-681-11	2.2k
R116,216	1-242-691-11	5.6k
R117,217	1-242-713-11	47k
R118,218	1-242-729-11	220k
R119,219	1-242-657-11	220
R120,220	1-242-681-11	2.2k
R121,221	1-242-691-11	5.6k
R122,222	1-242-661-11	330
R123,223	1-242-690-11	5.1k
R124,224	1-242-692-11	6.2k
R125,225	1-221-383-00	10k, adjustable
R126,226	1-242-681-11	2.2k
R127,227	1-242-707-11	27k
R128,228	1-242-725-11	150k
R129,229	1-242-685-11	3.3k
R130,230	1-242-709-11	33k
R131,231	1-242-665-11	470
R132,232	1-242-709-11	33k

IC-707S/SD

<u>Ref. No.</u>	<u>Part No.</u>	<u>Description</u>	<u>Ref. No.</u>	<u>Part No.</u>	<u>Description</u>
R133,233	1-242-661-11	330	R323,423	1-242-681-11	2.2 k
R134,234	1-242-673-11	1 k	R324,424		-----
R135,235	1-242-700-11	13 k	R325,425	1-242-697-11	10 k
R136,236	1-217-399-00	100	R326,426	1-242-721-11	100 k
R137,237	1-242-681-11	2.2 k	R327,427	1-242-721-11	100 k
		fusible			
R138,238	1-242-673-11	1 k	R328,428	1-242-737-11	470 k
R139,239	1-242-697-11	10 k	R329,429	1-242-681-11	2.2 k
R140,240	1-242-733-11	330 k	R330,430	1-221-311-00	5 k, adjustable
R141,241	1-242-697-11	10 k	R331,431	1-242-697-11	10 k
R142,242	1-242-733-11	330 k	R332,432	1-242-705-11	22 k
R143,243	1-242-697-11	10 k	R333,433	1-242-681-11	2.2 k
R144,244	1-242-733-11	330 k	R334,434	1-221-311-00	5 k, adjustable
R145,245	1-242-697-11	10 k	R335,435	1-242-701-11	15 k
R146,246	1-242-733-11	330 k	R336,436	1-242-657-11	220
R147,247	1-242-633-11	22	R337,437	1-221-311-00	5 k, adjustable
R148,248	1-242-633-11	22	R338,438	1-242-697-11	10 k
R149,249	1-242-633-11	22	R339,439	1-242-609-11	2.2
R150,250	1-242-633-11	22	R340,440	1-242-721-11	100 k
R301,401	1-242-725-11	150 k	R341,441	1-242-709-11	33 k
R302,402	1-242-739-11	560 k	R501	1-242-649-11	100
R303,403	1-242-649-11	100	R502	1-242-681-11	2.2 k
R304,404	1-242-721-11	100 k	R503	1-242-625-11	10
R305,405	1-242-707-11	27 k	R504	1-242-625-11	10
R306,406	1-242-705-11	22 k	R505	1-242-625-11	10
R307,407	1-242-692-11	6.2 k	R506	1-242-725-11	150 k
R308,408	1-242-692-11	6.2 k	R507	1-242-725-11	150 k
R309,409	1-242-697-11	10 k	R508	1-242-667-11	560
R310,410		390 k	R601	1-242-715-11	56 k
R311,411	1-242-705-11	22 k	R602	1-242-723-11	120 k
R312,412	1-242-681-11	2.2 k	R603	1-242-699-11	12 k
R313,413	1-242-685-11	3.3 k	R604	1-242-715-11	56 k
R314,414	1-242-705-11	22 k	R605	1-242-723-11	120 k
R315,415	1-242-729-11	220 k	R606	1-242-699-11	12 k
R316,416	1-242-665-11	470	R607	1-222-369-00	20 k (A), variable (MIC L-CH)
R317,417	1-242-677-11	1.5 k	R608	1-222-369-00	20 k (A), variable (MIC R-CH)
R318,418	1-242-709-11	33 k	R609	1-222-369-00	20 k (A), variable (LINE L-CH)
R319,419	1-242-707-11	27 k	R610	1-222-369-00	20 k (A), variable (LINE R-CH)
R320,420	1-242-663-11	390	R611	1-222-313-00	50 k (B), variable (ECHO SOS L-CH)
R321,421	1-242-677-11	1.5 k	R612	1-222-313-00	50 k (B), variable (ECHO SOS R-CH)
R322,422	1-242-657-11	220			

<u>Ref. No.</u>	<u>Part No.</u>	<u>Description</u>	<u>Ref. No.</u>	<u>Part No.</u>	<u>Description</u>
R613	1-222-314-00	20 k (B), variable (PB. L-CH)	R727	1-242-697-11	10 k
R614	1-222-314-00	20 k (B), variable (PB. R-CH)	R728	1-242-697-11	10 k
R615	1-242-697-11	10 k	R729	1-242-683-11	2.7 k
R616	1-242-697-11	10 k	R730	1-242-701-11	15 k
R617	1-242-684-11	3 k	R731	1-242-705-11	22 k
R618	1-242-684-11	3 k	R732	1-242-685-11	3.3 k
R619	1-242-673-11	1 k	R733		10 k
R620	1-242-673-11	1 k	R734	1-242-705-11	22 k
R621	1-242-673-11	1 k	R735	1-242-677-11	1.5 k
R622	1-242-721-11	100 k	R736	1-242-697-11	10 k
R623	1-242-691-11	5.6 k	R737	1-242-705-11	22 k
R624	1-242-721-11	100 k	R738	1-207-273-11	5.1 1.5 W, wire-wound
R625	1-242-691-11	5.6 k	R739	1-207-273-11	5.1 1.5 W, wire-wound
R626	1-242-691-11	5.6 k	R740	1-207-273-11	5.1 W, 1.5 W, wire-wound
R627	1-242-691-11	5.6 k	R741	1-242-705-11	22 k
R701	1-207-272-11	4.7 1.5 W, wire-wound	R742	1-242-709-11	33 k
R702	1-242-689-11	4.7 k	R743	1-242-690-11	5.1 k
R703	1-242-665-11	470	R744	1-242-657-11	220
R704	1-242-677-11	1.5 k	R745		18 k
R705	1-242-685-11	3.3 k	R801	1-205-506-11	1 k 25 W, cement coated
R706		2.2 k	R802	1-205-503-11	68 40 W, cement coated
R707	1-242-709-11	33 k	R803	1-205-503-11	68 40 W, cement coated
R708	1-242-665-11	470	R804	1-206-161-11	2.2 k 2 W, metal oxide
R709	1-242-677-11	1.5 k	R805	1-242-709-11	33 k ¼ W
R710	1-242-690-11	5.1 k			
R711	1-242-687-11	3.9 k	SWITCHES		
R712	1-242-681-11	2.2 k	S601	1-514-324-00	Slide, TAPE SELECTOR
R713	1-242-705-11	22 k	S602	1-514-692-00	Lever, MONITOR (L-CH)
R714	1-242-691-11	5.6 k	S603	1-514-692-00	Lever, MONITOR (R-CH)
R715	1-244-885-11	3.3 k ½ W	S604	1-514-693-00	Lever, ECHO/OFF/SOS
R716	1-242-705-11	22 k	S605	1-514-728-00	Key, REC MODE (L-CH)
R717	1-242-665-11	470	S606	1-514-728-00	Key, REC MODE (R-CH)
R718	1-242-709-11	33 k	S607	1-514-482-00	Key, TAPE SPEED
R719		10 k	S801	1-516-005-00	Seasaw, POWER (Canadian, E model)
R720	1-242-673-11	1 k		1-514-655-71	Seasaw, POWER (AEP model)
R721	1-242-709-11	33 k	S802	1-514-057-00	Micro, REC
R722	1-242-709-11	33 k	S803	1-514-057-00	Micro, REW
R723	1-242-707-11	27 k	S804	1-514-057-00	Micro, STOP
R724	1-242-713-11	47 k	S805	1-514-057-00	Micro, PLAY
R725	1-242-713-11	47 k	S806	1-514-057-00	Micro, FF
R726	1-242-705-11	22 k	S807	1-514-680-00	Key, TAPE SHIFT
			S808	1-514-530-21	Micro, shut-off

<u>Ref. No.</u>	<u>Part No.</u>	<u>Description</u>
JACKS		
J601	1-507-142-00	Phono, LINE IN (L-CH)
J602	1-507-142-00	Phono, LINE IN (R-CH)
J603	1-507-142-00	Phono, LINE OUT (L-CH)
J604	1-507-142-00	Phono, LINE OUT (R-CH)
J605	1-507-281-00	MIC (L-CH)
J606	1-507-281-00	MIC (R-CH)
J607	1-507-282-00	Binaural, HEADPHONE
CONNECTORS		
CNJ601~605	1-507-300-00	22 p, circuit board
CNJ606	1-509-029-00	REC/PB
CNJ801	1-509-547-00	AC INLET (AEP, Canadian model)
	1-509-801-00	AC INLET (E model)
CNJ802	1-509-952-00	OUTLET (UNSWITCHED) (E model only)
CNJ803	1-507-300-00	22 p, circuit board
CNJ804	1-507-301-00	18 p, circuit board
CNJ805	1-507-225-00	11 p, remote control
CNJ806	1-507-307-00	14 p, circuit board
CNJ807	1-509-427-XX	VOLTAGE SELECTOR (AEP, E model only)
CNJ808	1-508-400-00	3 p, nylon
CNP601	1-539-437-00	22 p, docking
CNP602	1-509-371-00	3 p, nylon; including terminal
	1-509-372-00	Pin, terminal; included in nylon connector (CNP602)
CNP801	1-506-180-00	11 p, remote control dummy
CNP802	1-539-436-00	Head, including terminal pin
	1-508-411-00	Pin, terminal; included in head connector (CNP802)
LAMPS		
PL603	1-518-093-11	REC, 0.1A (L-CH)
PL604	1-518-093-11	REC, 0.1A (R-CH)
PL801	1-518-053-21	FF Button, 28 V; 0.04A
PL802	1-518-053-21	REW Button, 28V; 0.04A
PL803	1-518-053-21	PLAY Button, 28V; 0.04A
PL804	1-518-053-21	REC Button, 28 V; 0.04A

<u>Ref. No.</u>	<u>Part No.</u>	<u>Description</u>
SOCKET		
PL801~804	1-517-018-00	Lamp
ENCAPSULATED COMPONENTS		
CP701~704	1-101-534-00	0.1 μ F + 120 Ω 350 V
CP801	1-231-298-00	0.1 + 120 250 V
CP802	1-231-341-00	0.033 + 120 250 V (Canadian model)
	1-231-298-00	0.1 + 120 250 V (AEP, E model)
CP803	1-231-298-00	0.1 + 120 250 V
CP804	1-101-534-00	0.1 + 120 350 V (AEP model only)
MISCELLANEOUS		
ME601	1-524-067-00	Meter, VU; including PL601 (L-CH)
ME602	1-524-067-00	Meter, VU; including PL602 (R-CH)
M801	8-831-634-21	Motor, capstan (HC-634D7)
M802	8-836-624-07	Motor, supply reel (UC-624k)
M803	8-836-624-07	Motor, take-up reel (UC-624k)
M801	1-454-052-00	Solenoid, pinch roller
M802	1-454-053-00	Solenoid, shifter
M803	1-454-053-00	Solenoid, brake
F801	1-532-268-XX	Fuse, 2A (Canadian model)
	1-532-078-00	Fuse, T1A (AEP model)
	1-532-417-00	Fuse, 2A (E model)
F802	1-532-078-00	Fuse, T1A
F803	1-532-215-00	Fuse, T0.8A
F804	1-532-203-00	Fuse, T2A
		} AEP model only
FB801	1-533-141-00	Holder, fuse (Canadian, E model)
	1-533-069-XX	Holder, fuse (AEP model)
	1-535-506-00	Terminal, point compression
	1-536-213-00	Terminal Strip, 5P
H801,802	8-828-522-20	Head, erase (EF85-2202)
H803,804	8-824-122-20	Head, record (RP30-2202)
H805,806	8-821-228-24	Head, playback (PP30-2802A)
H807	1-459-051-00	Head, sensing
RY501	1-515-127-00	Relay
RY701~704	1-515-127-00	Relay

SECTION 7
EXPLODED VIEWS

7-1. CABINET - Top View -

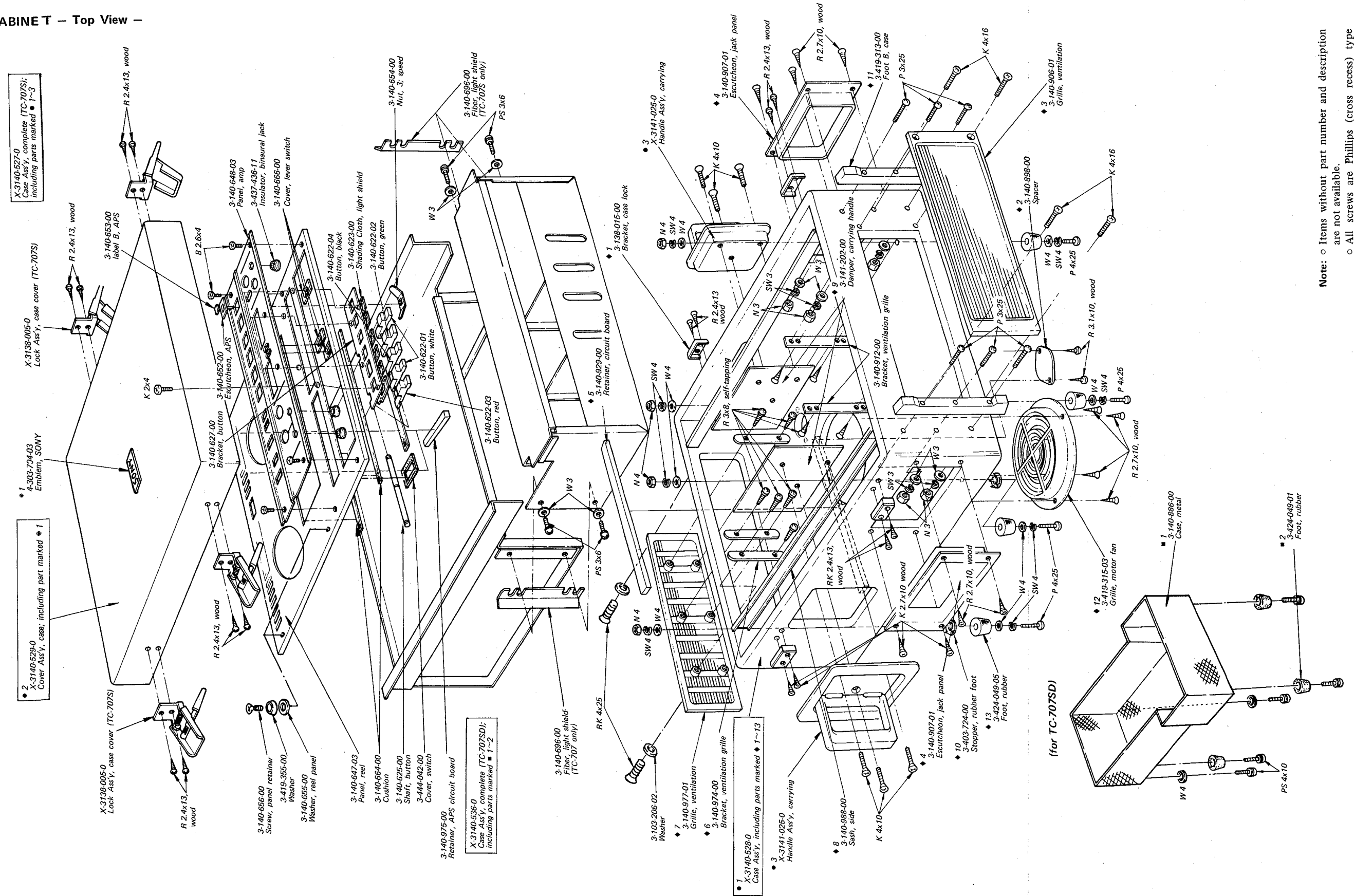

Note: ○ Items without part number and description are not available.
○ All screws are Phillips (cross recess) type unless otherwise noted.
(-) = slotted head

TC-707S/SD TC-707S/SD

7-2. AMP CHASSIS PANEL – Top View –

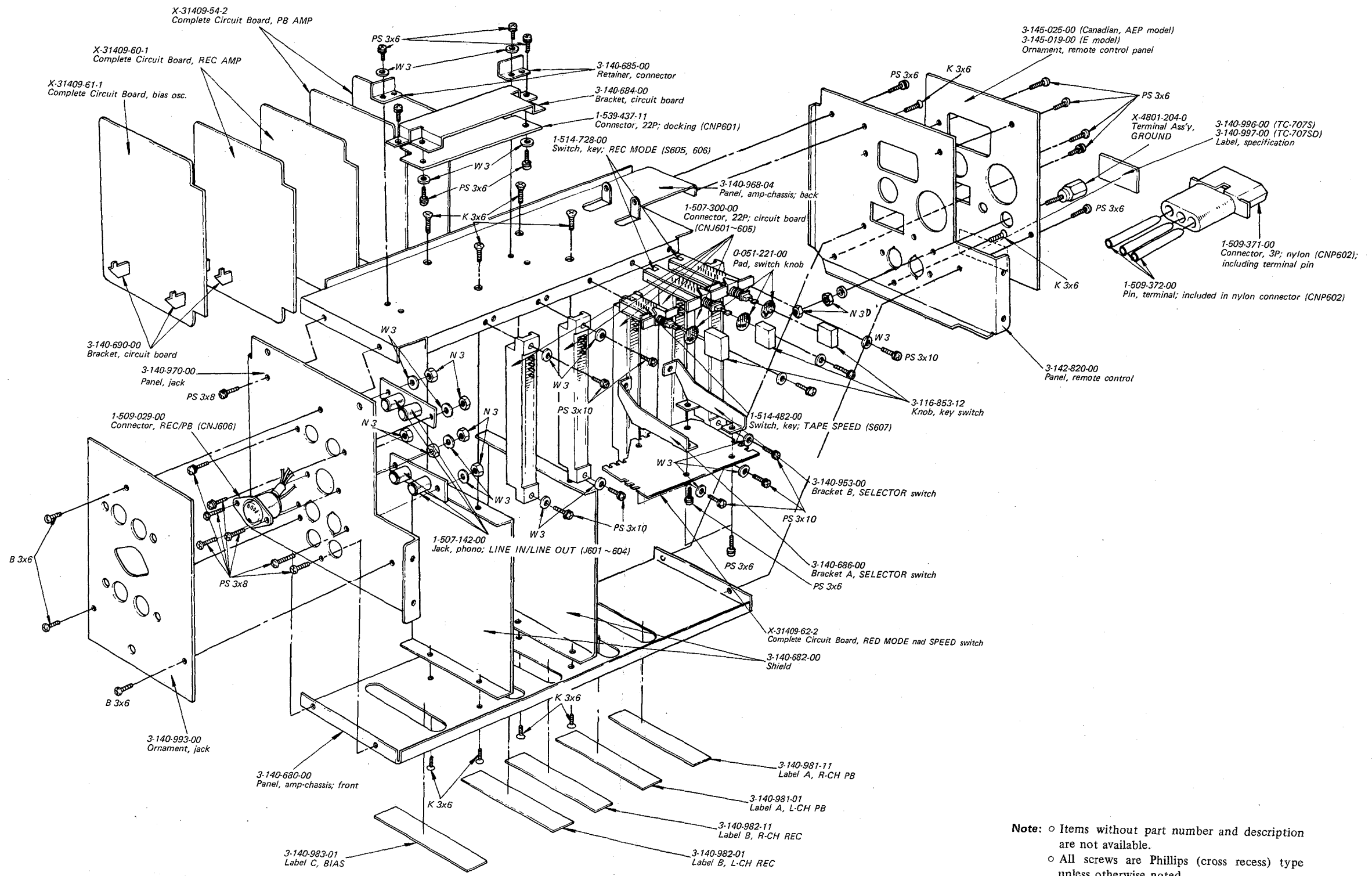

Note:

- Items without part number and description are not available.
- All screws are Phillips (cross recess) type unless otherwise noted.
- (-) = slotted head

TC-707S/SD TC-707S/SD

7-3. AMP SUB-PANEL — Top View —

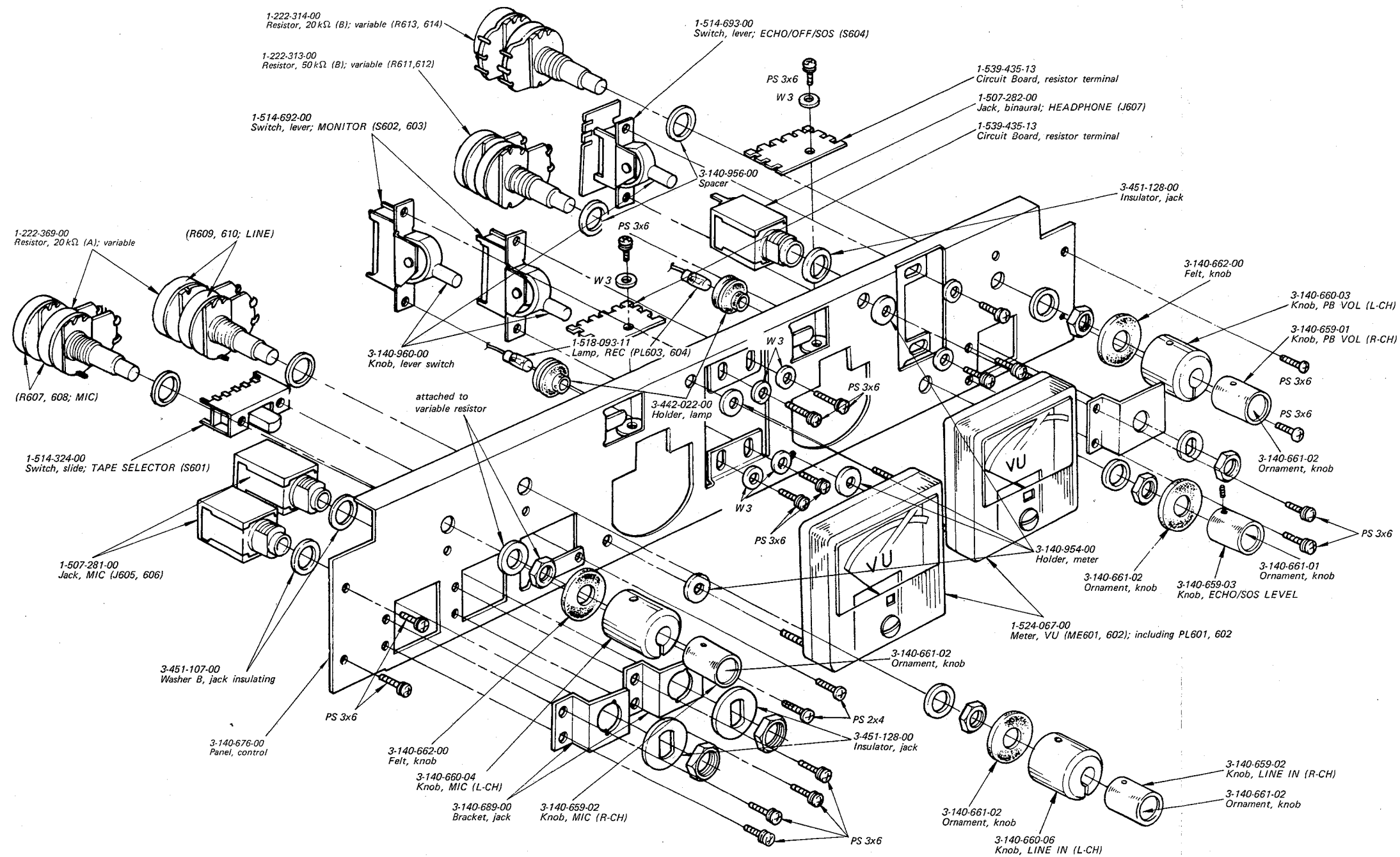

Note:

- Items without part number and description are not available.
- All screws are Phillips (cross recess) type unless otherwise noted.
- (-) = slotted head

TC-707S/SD TC-707S/SD

7-4. HEAD DECK - Top View - (1)

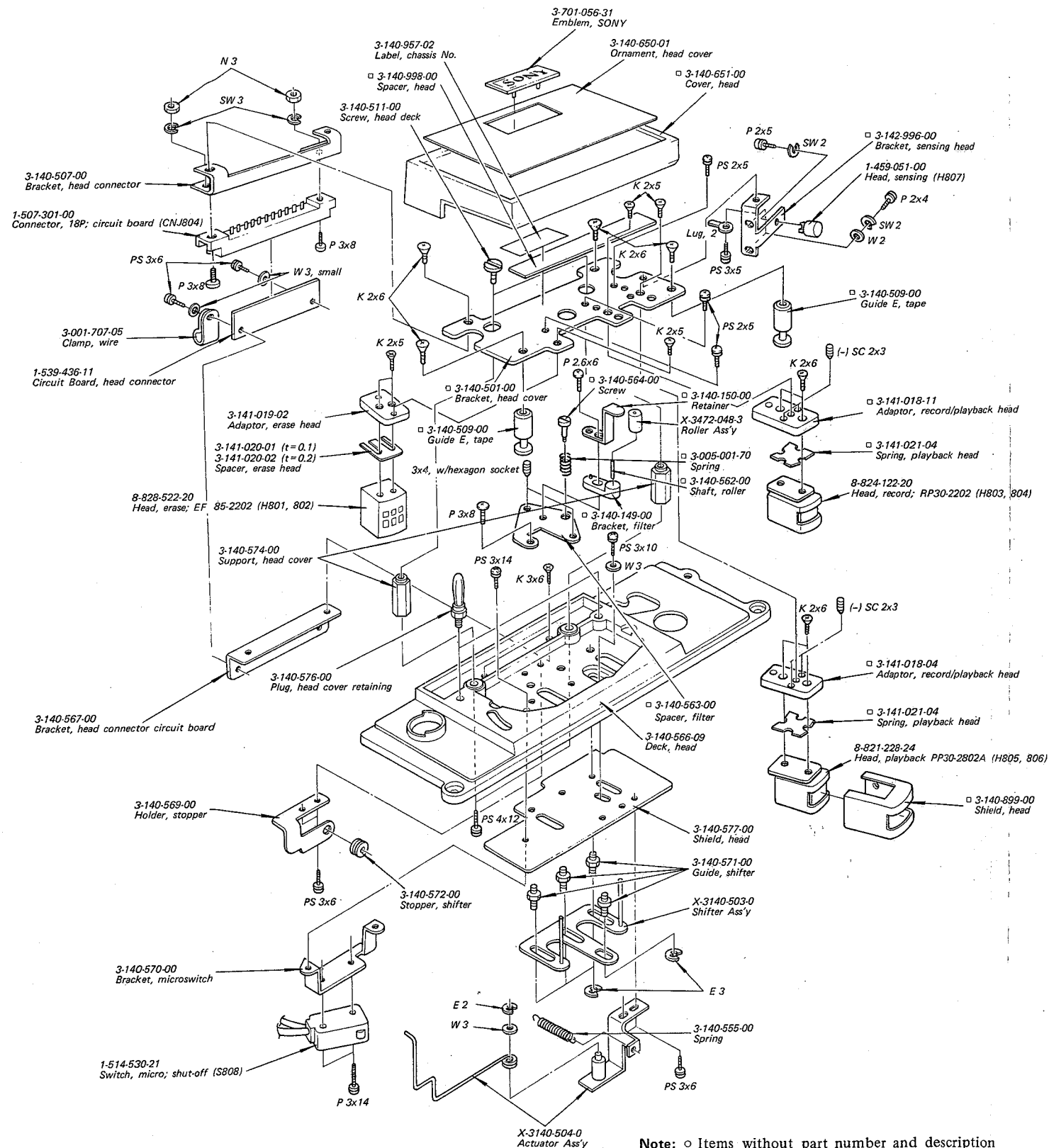

□: TC-707S : serial No. 1261 ~ 1440, 11501 ~ 11600,
TC-707SD: serial No. 1353 ~ 1592, 11601 ~ 11950.

Note: ○ Items without part number and description are not available.
○ All screws are Phillips (cross recess) type unless otherwise noted.
(-) = slotted head

(2)

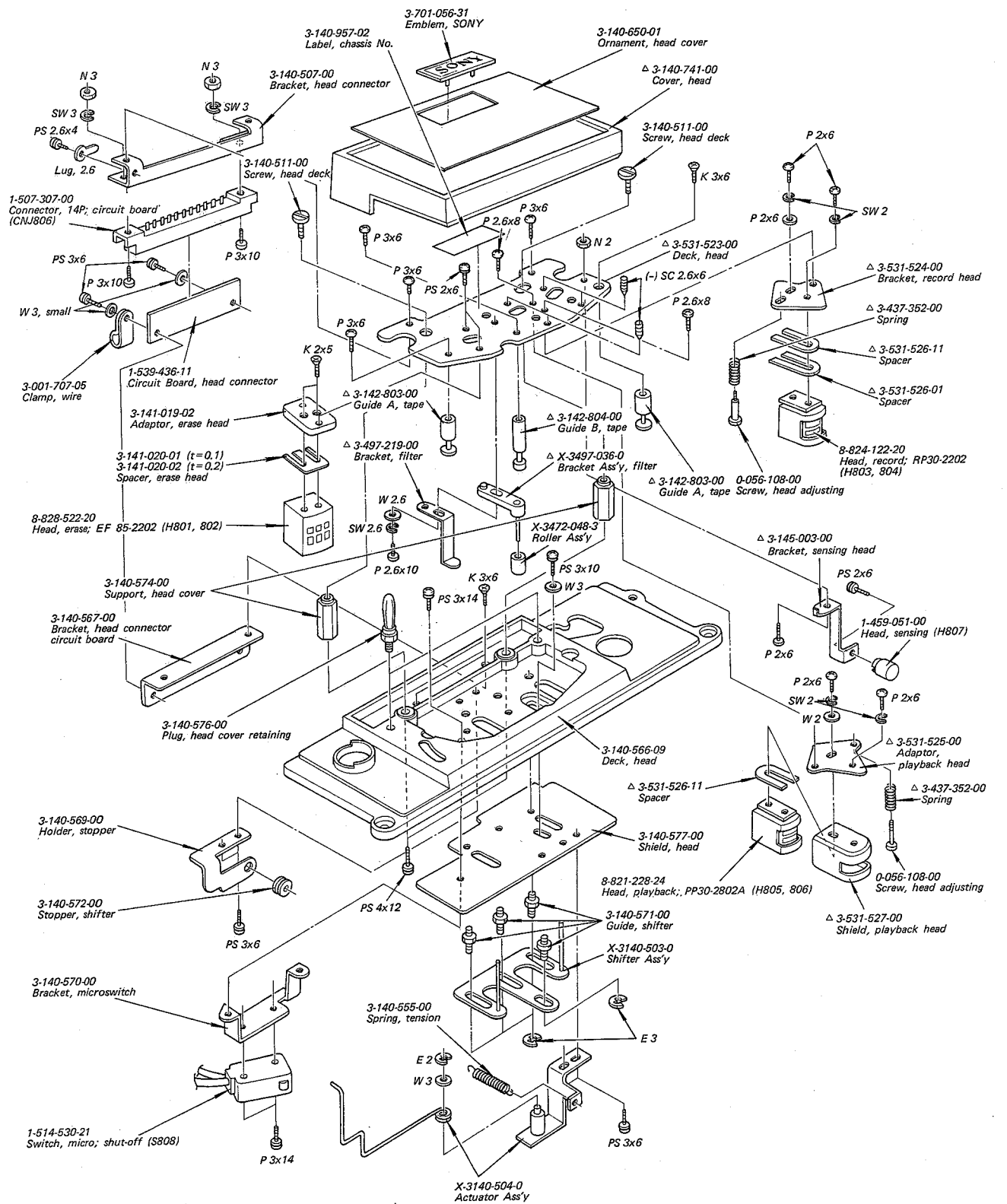

△: TC-707S : serial No. 11601 and later,
TC-707SD: serial No. 11951 and later.

Note: ○ Items without part number and description are not available.
○ All screws are Phillips (cross recess) type unless otherwise noted.
(-) = slotted head

7-5. FLYWHEEL – Top View –

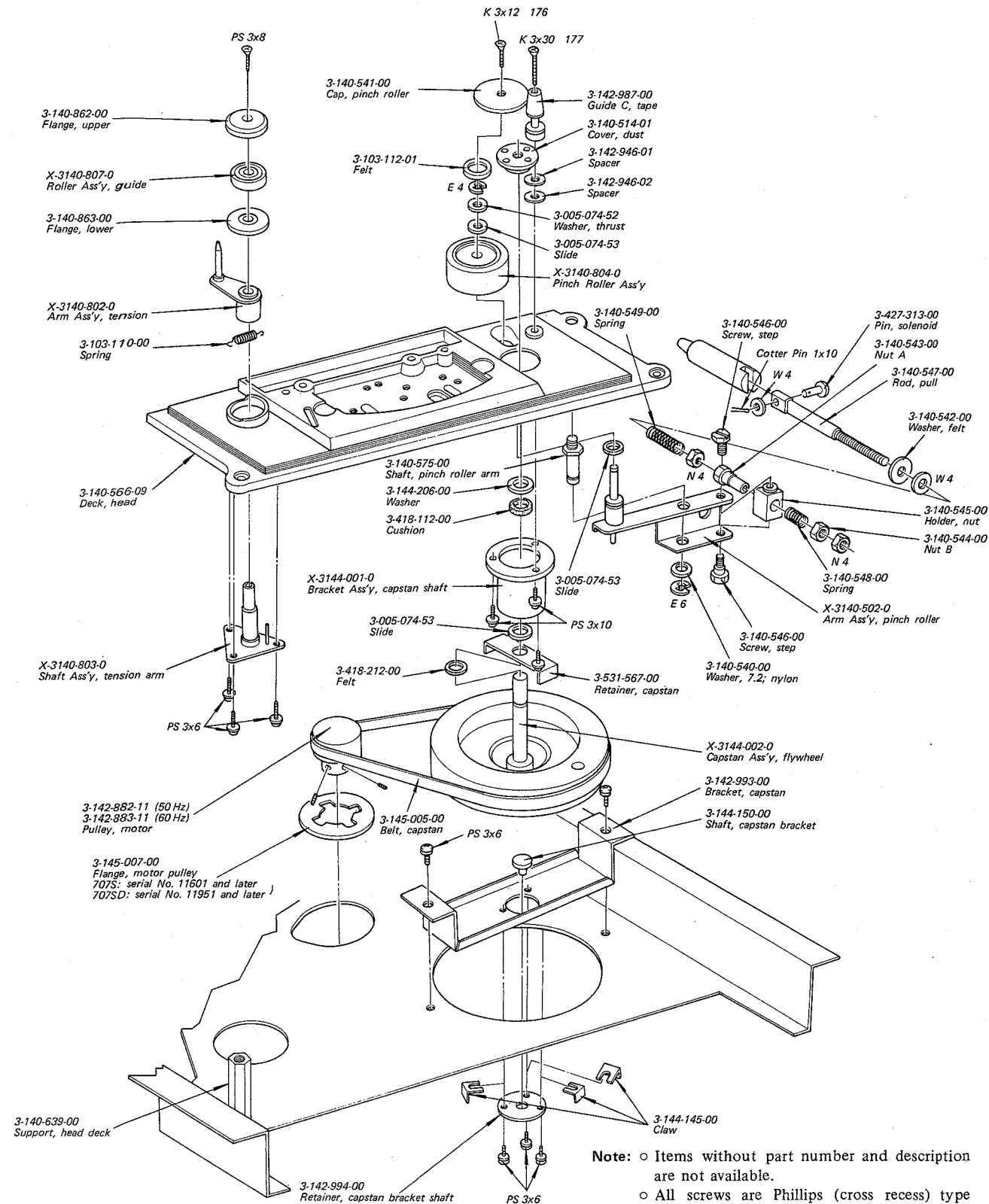

Note: ○ Items without part number and description are not available.
 ○ All screws are Phillips (cross recess) type unless otherwise noted.
 (-) = slotted head

7-6. CHASSIS – Top View (1) –

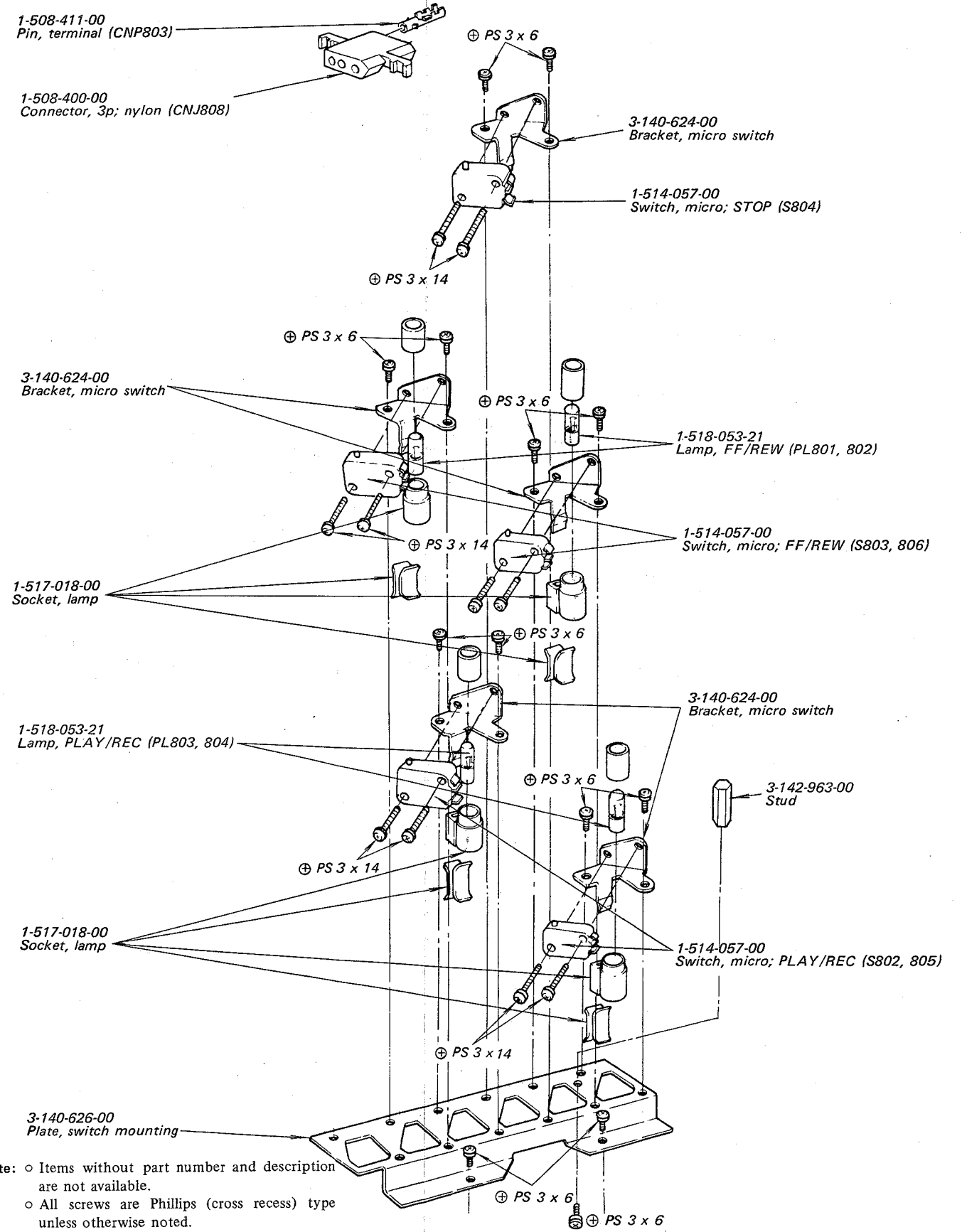

Note: ○ Items without part number and description are not available.
 ○ All screws are Phillips (cross recess) type unless otherwise noted.
 (-) = slotted head

TC-707S/SD TC-707S/SD

7-7. CHASSIS - Top View (2) -

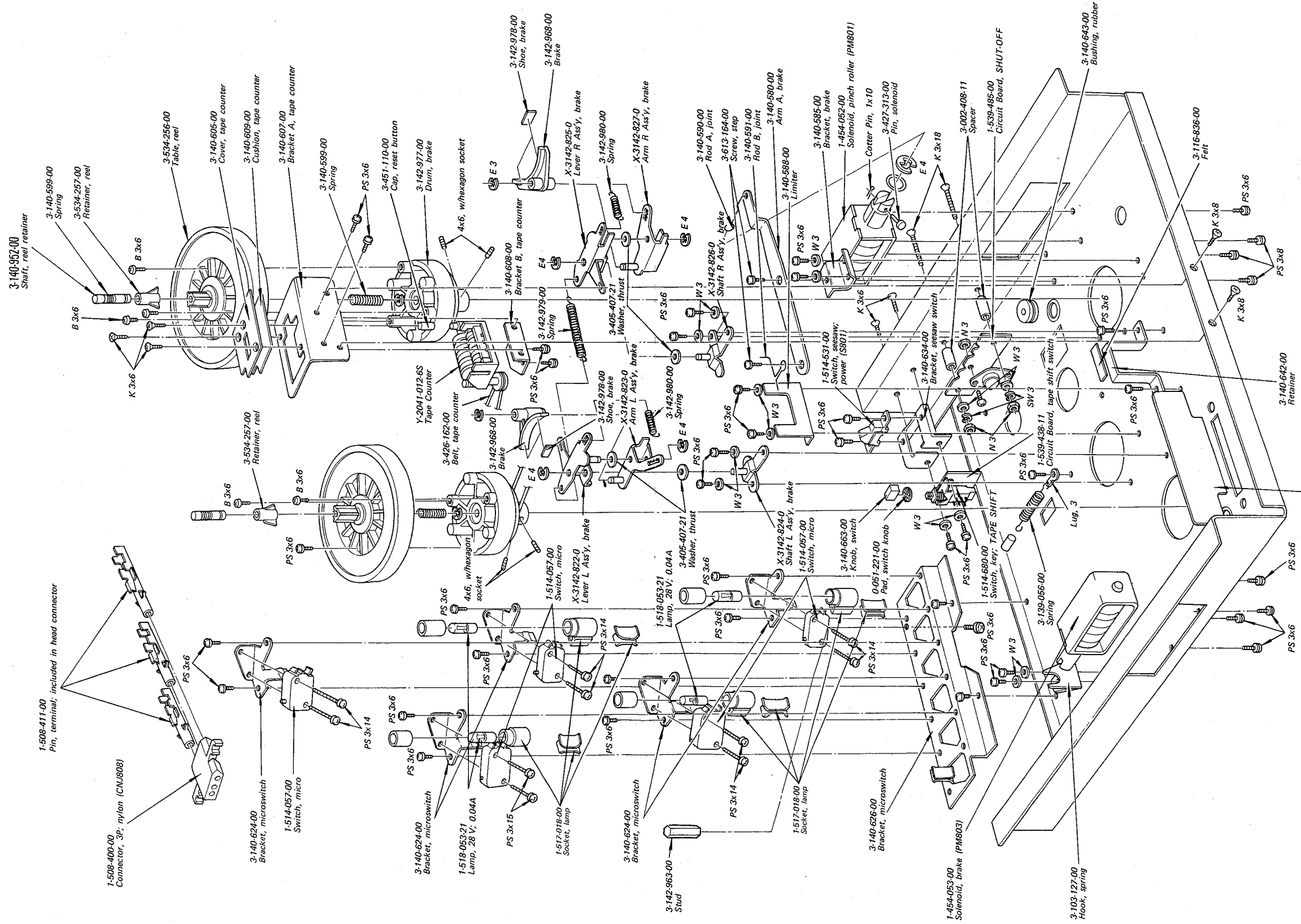

Note: ○ Items without part number and description are not available.
 ○ All screws are Phillips (cross recess) type unless otherwise noted.
 (-) = slotted head

1-539-687-00
Circuit Board, dummy; ATS & APS

TC-707S/SD TC-707S/SD

7-8. CHASSIS — Bottom View —

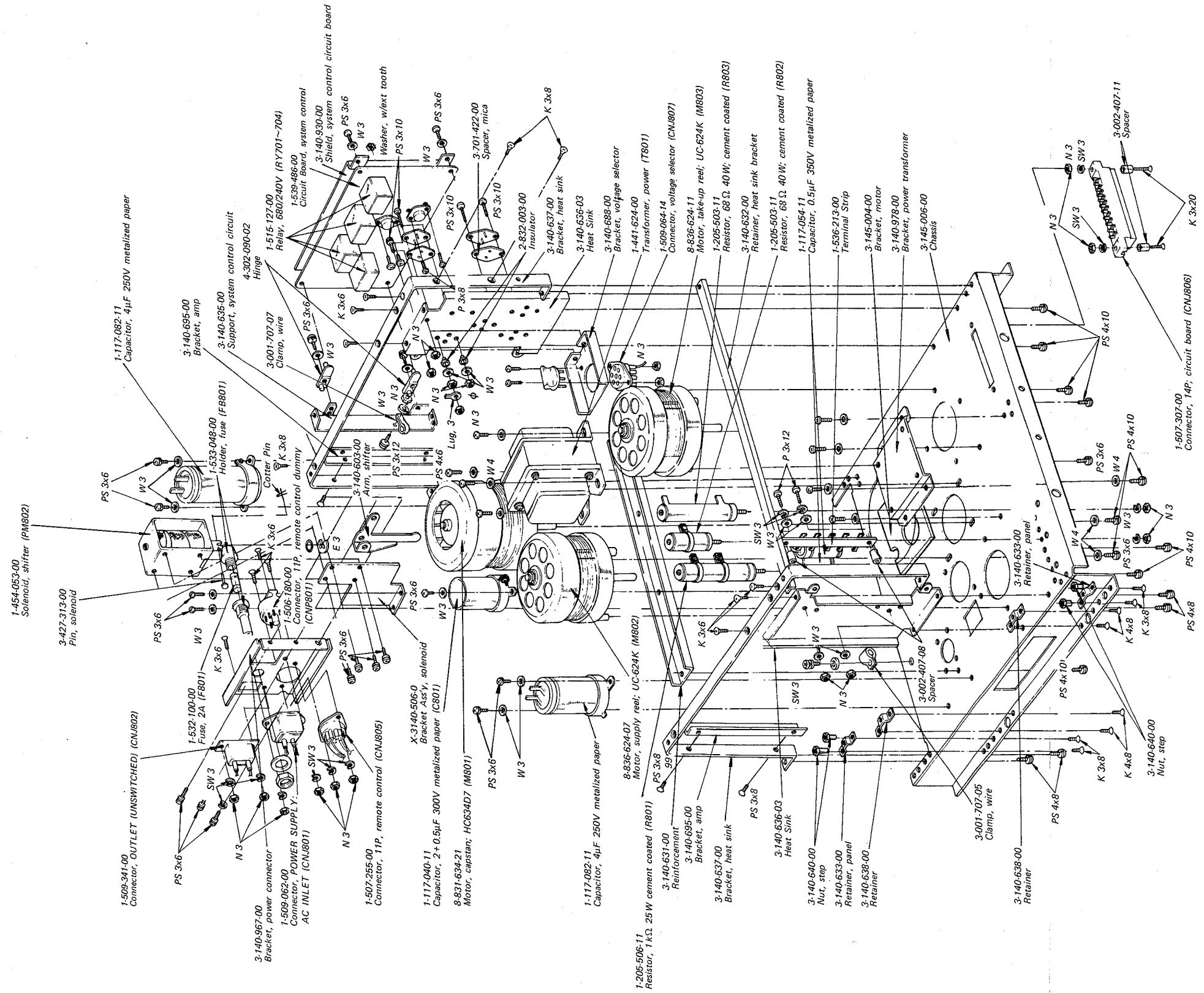

Note: ○ Items without part number and description are not available.
 ○ All screws are Phillips (cross recess) type unless otherwise noted.
 (-) = slotted head

**SECTION 8
HARDWARE**

7-9. PACKING

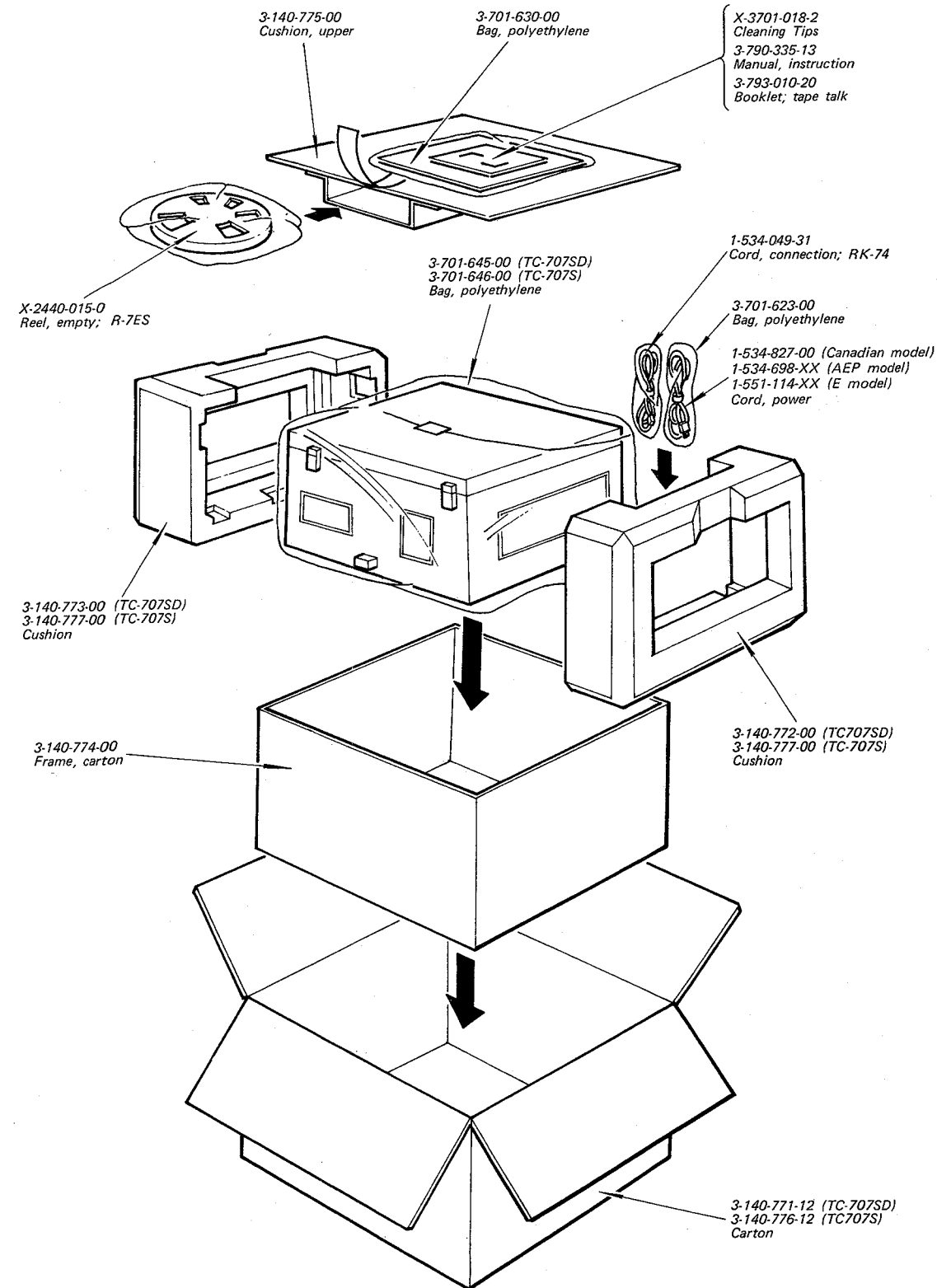

Note: ○ Items without part number and description are not available.

Part No.	Description	Part No.	Description
SCREWS			
All screws are Phillips type (cross recess type) unless otherwise indicated. (-): slotted head			
7-621-255-24	P 2 x 4	7-682-649-02	PS 3 x 10
7-621-255-34	P 2 x 5	7-682-650-02	PS 3 x 12
7-621-259-47	P 2.6 x 6	7-682-651-02	PS 3 x 14
7-621-261-54	P 3 x 8	7-682-659-02	PS 4 x 15
7-621-555-34	K 2 x 5	7-682-661-02	PS 4 x 8
7-621-555-44	K 2 x 6	7-682-662-02	PS 4 x 10
7-621-710-24	(-) SC 2 x 3, w/hexagon socket	7-682-663-02	PS 4 x 12
7-621-710-27	(-) SC 2 x 3, w/hexagon socket	7-683-237-01	3 x 3, w/hexagon socket
7-621-712-55	2.6 x 6, w/hexagon socket	7-683-238-01	3 x 4, w/hexagon socket
7-621-770-36	B 2.6 x 4	7-683-247-31	4 x 6, w/hexagon socket
HEXAGONAL NUTS			
7-621-771-19	B 2 x 6	7-622-105-02	2
7-621-842-31	R 2.7 x 10, wood	7-622-107-04	2.6
7-682-127-01	P 2 x 8	7-684-013-02	3
7-682-150-02	P 3 x 12	7-684-014-02	4
7-682-153-02	P 3 x 20	WASHERS	
7-682-163-02	P 4 x 12	7-623-105-14	2, middle
7-682-247-02	K 3 x 6	7-623-108-14	3, middle
7-682-248-02	K 3 x 8	7-623-110-14	4
7-682-248-04	K 3 x 8	7-623-205-21	2, spring
7-682-249-04	K 3 x 10	7-623-207-21	2.6, spring
7-682-250-02	K 3 x 12	7-623-208-21	3, spring
7-682-250-04	K 3 x 12	7-623-210-21	4, spring
7-682-253-02	K 3 x 20	7-623-408-01	3, w/ext tooth
7-682-253-04	K 3 x 20	RETAINING RINGS	
7-682-260-02	K 4 x 6	7-624-106-01	E 3
7-682-261-02	K 4 x 8	7-624-108-01	E 4
7-682-266-04	K 4 x 20	7-624-110-01	E 4
7-682-267-04	K 4 x 25	LUGS	
7-682-356-14	RK 3 x 35	7-623-505-01	2
7-682-367-04	RK 4 x 25	7-623-507-01	2.6
7-682-547-04	B 3 x 6	7-623-508-01	3
7-682-548-05	B 3 x 8	7-626-202-31	Pin, cotter; 1 x 10
7-682-625-00	PS 2 x 5		
7-682-626-01	PS 2 x 6		
7-682-634-01	PS 2.6 x 5		
7-682-636-01	PS 2.3 x 8		
7-682-637-01	PS 2.5 x 10		
7-682-647-02	PS 3 x 6		
7-682-648-02	PS 3 x 8		

Sony Corporation

© 1974

— 52 —