

TC-717/717M

SERVICE MANUAL

US Model
 Canadian Model
 AEP Model
 UK Model
 TC-717M
 E Model
 TC-717



TC-717 is the cassette deck section in FH-717R.

TC-717M is the cassette deck section in MHC-2200/2200CD.

Photo: TC-717M

SPECIFICATIONS

Recording system 4-track 2-channel stereo
 Frequency response

Used cassette	
TYPE I (Sony HF-S)	40-13,000 Hz (± 3 dB)
TYPE II (Sony UCX)	40-14,000 Hz (± 3 dB)

Wow and flutter 0.1% WRMS
 $\pm 0.2\%$ (DIN)



Dimensions/Weight

Approx. 225 x 120 x 230 mm (8 $\frac{7}{8}$ x 4 $\frac{3}{4}$ x 9 $\frac{1}{8}$ inches)	Approx. 1.7kg (3 lb 12 oz) net
--	-----------------------------------

* incl. projecting parts and controls

Dolby noise reduction manufactured under license from Dolby Laboratories Licensing Corporation. "DOLBY" and the double-D symbol  are trademarks of Dolby Laboratories Licensing Corporation.

SAFETY-RELATED COMPONENT WARNING!!

COMPONENTS IDENTIFIED BY MARK  OR DOTTED LINE WITH MARK  ON THE SCHEMATIC DIAGRAMS AND IN THE PARTS LIST ARE CRITICAL TO SAFE OPERATION. REPLACE THESE COMPONENTS WITH SONY PARTS WHOSE PART NUMBERS APPEAR AS SHOWN IN THIS MANUAL OR IN SUPPLEMENTS PUBLISHED BY SONY.

ATTENTION AU COMPOSANT AYANT RAPPORT À LA SÉCURITÉ!

LES COMPOSANTS IDENTIFIÉS PAR UNE MARQUE  SUR LES DIAGRAMMES SCHÉMATIQUES ET LA LISTE DES PIÈCES SONT CRITIQUES POUR LA SÉCURITÉ DE FONCTIONNEMENT. NE REMPLACER CES COMPOSANTS QUE PAR DES PIÈCES SONY DONT LES NUMÉROS SONT DONNÉS DANS CE MANUEL OU DANS LES SUPPLÉMENTS PUBLIÉS PAR SONY.

Model Name Using Similar Mechanism	TC-R707/R707M
Tape Transport Mechanism Type	TCM-170RB16

MODEL IDENTIFICATION

US, Canadian, AEP, UK, E model

TC-717
 TC-717M

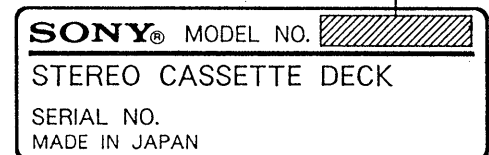

West Germany model

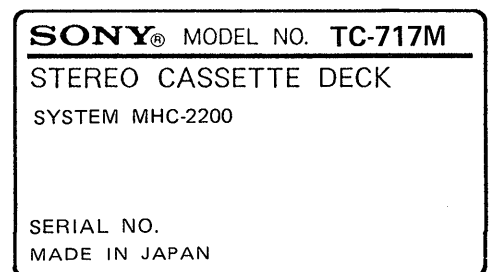

STEREO CASSETTE DECK
SONY®

SECTION 1 SERVICING NOTES

REPAIRING PRECAUTION

[To apply B+ voltage]

The power of this unit is fed from amplifier.
Because of this, connect the regulated power supply as illustrated below when this unit alone operates.

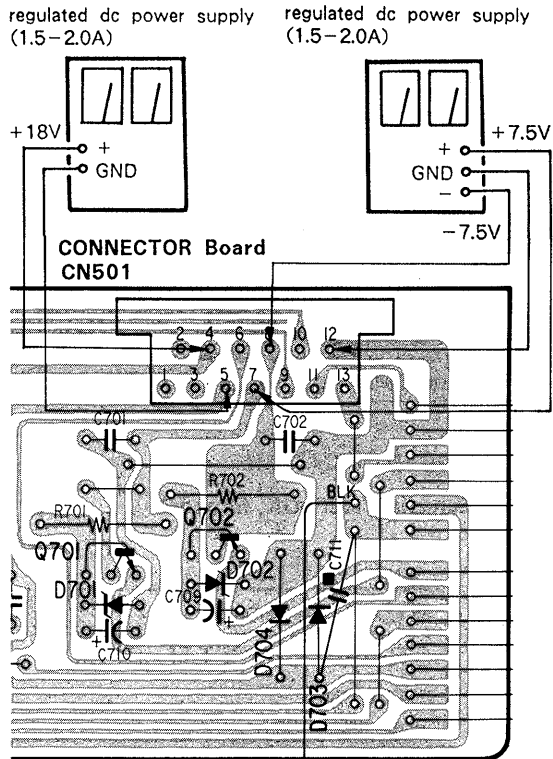

SERVICE MODE

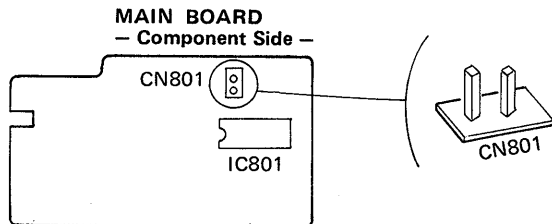

When short-circuit CN801 on Main Board, the recording signal can be monitored from LINE OUT terminal on recording.

SECTION 2 GENERAL

PARTS IDENTIFICATION

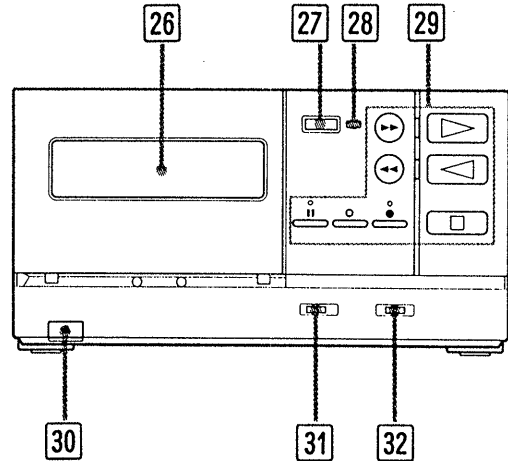

- 26 Cassette holder
- 27 TAPE COUNTER
- 28 RESET (counter reset) button
- 29 Tape operation buttons
 - ◀▶▶▶:Fast winding
 - ▶:Forward play
 - ◀:Reverse play
 - :Stop
 - ⏸:Pause
 - :Record muting
 - :Record
- 30 ▲ EJECT button
- 31 DIRECTION MODE selector
- 32 DOLBY NR switch

SECTION 3 ADJUSTMENTS

3-1. MECHANICAL ADJUSTMENTS

PRECAUTION

1. Clean the following parts with a denatured-alcohol-moistened swab :

record/playback head	pinch roller
erase head	rubber belts
capstan	idler
2. Demagnetize the record/playback head with a head demagnetizer.
3. Do not use a magnetized screwdriver for the adjustments.
4. After the adjustments, apply suitable locking compound to the parts adjusted.
5. The adjustments should be performed with the rated power supply voltage unless otherwise noted.
6. Switch position
 DOLBY NR : OFF
 DIRECTION MODE : ⇄

Torque Measurement

Torque	Torque Meter	Meter Reading
FWD	CQ-102C	27 to 75g · cm (0.378 to 1.05 oz · inch)
FWD Back tension	CQ-102C	1 to 10g · cm (0.014 to 0.14 oz · inch)
REV	CQ-102RC	27 to 75g · cm (0.378 to 1.05 oz · inch)
REV Back Tension	CQ-102RC	1 to 10g · cm (0.014 to 0.14 oz · inch)
FF, REW	CQ-102B	95 to 165g · cm (1.33 to 2.31 oz · inch)

3-2. ELECTRICAL ADJUSTMENTS

Note : The adjustment should be performed in the order given in the service manual.

The adjustments should be performed for both L-CH and R-CH.

- Switches and controls should be set as follows unless otherwise specified.

DOLBY NR switch	: OFF
DIRECTION MODE switch	: ⇄
- Standard Record :
 Deliver the standard input signal level to the input jack and set the REC LEVEL control to obtain the standard output signal level.

—Record Mode—

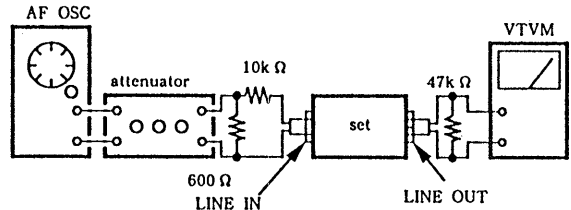

Standard Input Level

	LINE IN
source impedance	10k Ω
input level	0.25V (-10dB)

Standard Output Level

	LINE OUT
load impedance	47k Ω
output level	0.44V (-5dB)

• Test tape

Type	Signal	Used for
P-4-A100	10kHz, -10dB	Azimuth Adjustment
P-4-L300	315Hz, 0dB	PB LEVEL Adjustment
WS-48B	3kHz, 0dB	Tape Speed Adjustment

Location of LINE IN/OUT

CONNECTOR Board CN501

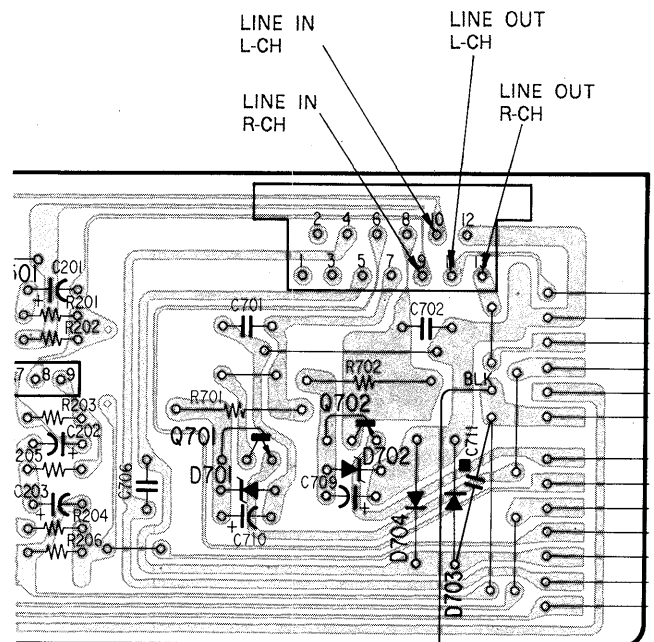

Record/Playback Head Azimuth Adjustment

Procedure :

1. Mode : FWD playback

test tape
P-4-A100
(10kHz, -10dB)

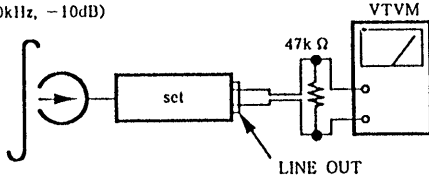

2. Turn the adjustment screw for the maximum output levels. If these levels do not match, turn the adjustment screw until both of output levels match together within 1dB.

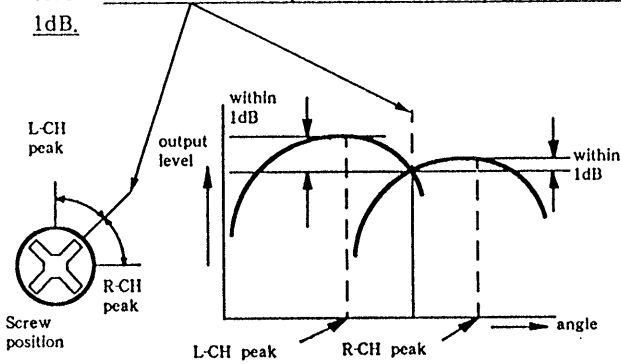

3. Phase Check
Mode : playback

test tape
P-4-A100
(10kHz, -10dB)

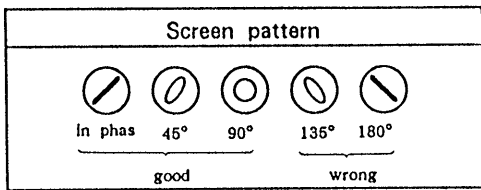
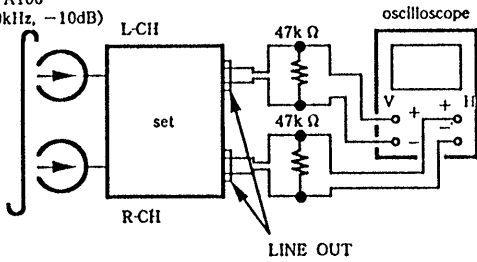

4. Set in the REV mode and repeat the step 1-3.
5. After the adjustment, lock the screws with locking compound.

Adjustment Location : Record/Playback head
(Adjustable without disassembly.)

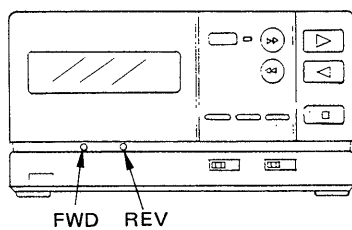
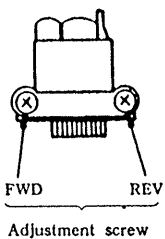

Tape Speed Adjustment

Procedure :

Mode : FWD playback

test tape
WS-48B
(3kHz, 0dB)

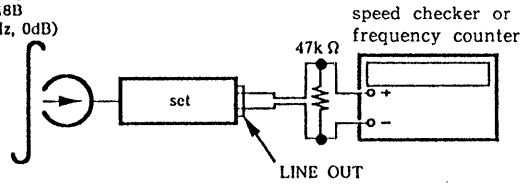

Specifications :

SPEED CHECKER	FREQUENCY COUNTER
1 to 0,3%	2,970 to 2,990Hz

Adjustment with the switch fixed variable resistor built in the motor so that the frequency difference between the beginning and the end of the tape should be within 1,5% (45Hz). Frequency difference between the beginning and the end of the tape should be within.

Adjustment Location :

: motor (M901) rear side

Playback Level Adjustment

Procedure :

Mode : playback

test tape
P-4-L300
(315kHz, 0dB)

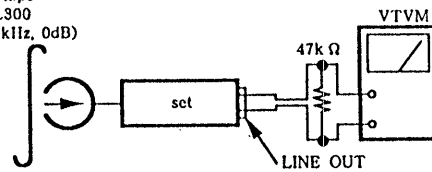

Adjust RV41 (L-CH), RV61 (R-CH) so that the reading on VTVM meets the specification below.

Specification :

LINE OUT level : $-10 \pm 0,5\text{dB}$ (0,23 to 0,26V)

Level difference between channels : less than 0,5dB

Check that the LINE OUT level does not change in playback mode while changing the mode from playback to stop several times.

Adjustment Location : MD (B) board

Record Bias Adjustment

Setting :

REC LEVEL control : standard record (See page 3.)

Procedure :

1. Mode : record

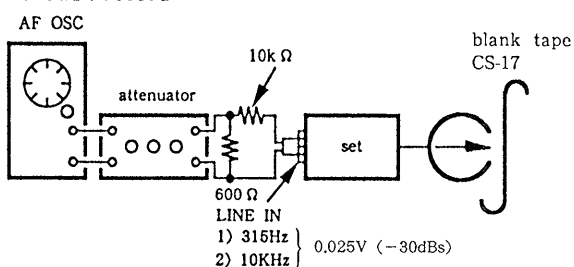

2. Mode : playback

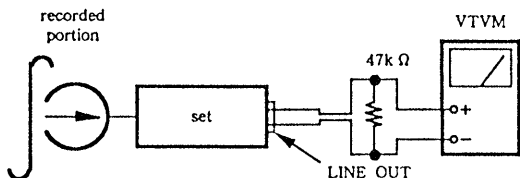

Confirm that the 10kHz playback output is $0 \pm 0.5\text{dB}$ relative to the 315Hz output. If necessary, adjust RV42 (L-CH), RV62 (R-CH) and repeat the steps given above.

Adjustment Location : MD (B) board

Record Level Adjustment

Setting :

REC LEVEL control : standard record (See page 3.)

Procedure :

1. Mode : record

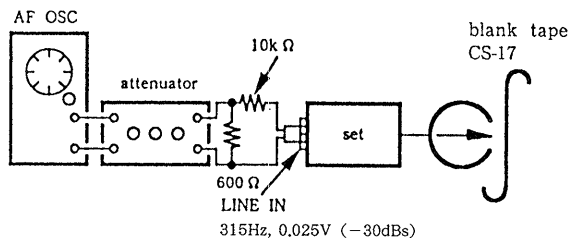

2. Mode : playback

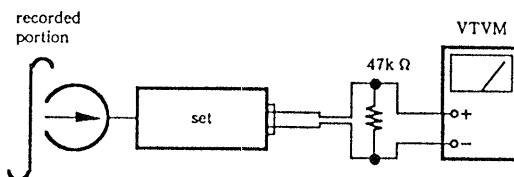

3. Play back the signal recorded in step 1.

Confirm that the signal level is within the specification below. If necessary, adjust RV111 (L-CH), RV211 (R-CH) and repeat the step 1 to 3.

Specification : LINE OUT level: $-30\text{dB} \pm 0.5\text{dBs}$ (0.023 to 0.026V)

Adjustment Location : main board

ADJUSTING PARTS LOCATION DIAGRAM

• MD (B) Board -Component Side-

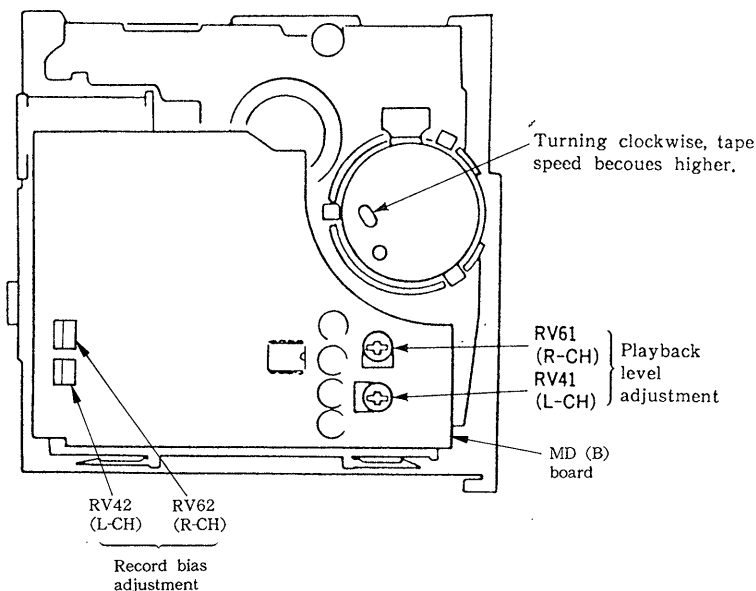

• Main Board -Conductor Side-

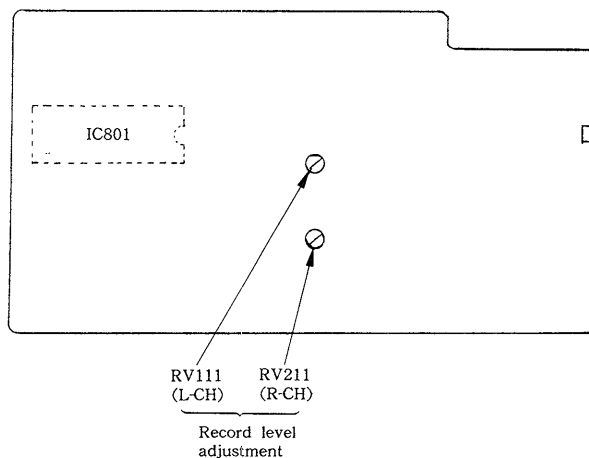

SECTION 4
DIAGRAMS

4-1. PRINTED WIRING BOARDS

Note:
 ● ○ : parts extracted from the component side.
 ● ● : parts extracted from the conductor side.

● Semiconductor Lead Layouts

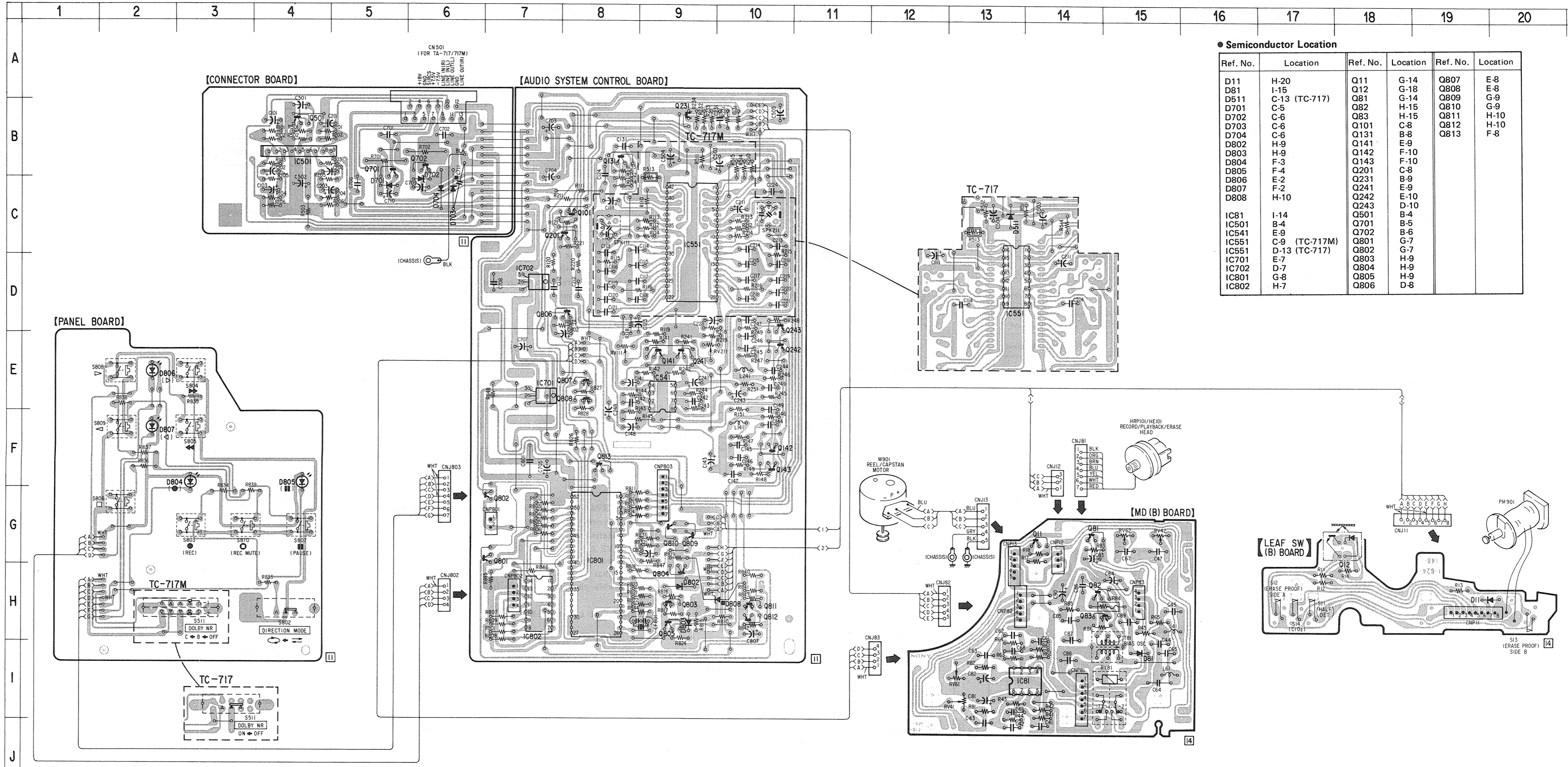
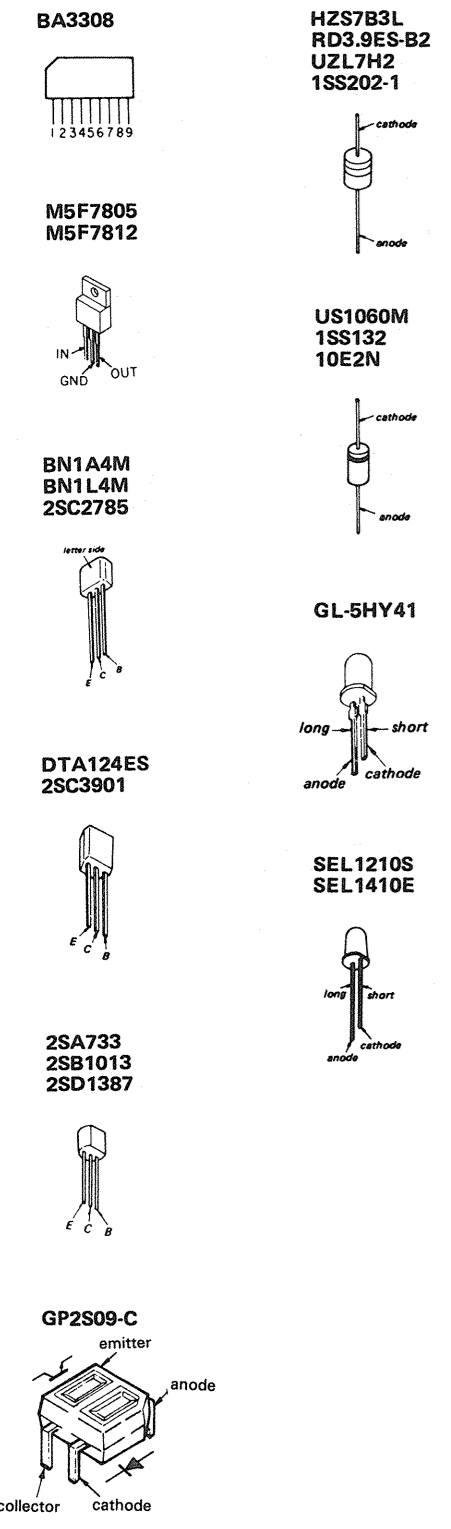

● Semiconductor Location

Ref. No.	Location	Ref. No.	Location	Ref. No.	Location
D11	H-20	Q11	G-14	Q807	E-8
D81	I-15	Q12	G-18	Q808	E-8
D511	C-13 (TC-717)	Q81	G-14	Q809	G-9
D701	C-5	Q82	H-15	Q810	G-9
D702	C-6	Q83	H-15	Q811	H-10
D703	C-6	Q101	C-8	Q812	H-10
D704	C-6	Q131	B-8	Q813	F-8
D802	H-9	Q141	E-9		
D803	H-9	Q142	F-10		
D804	F-3	Q143	F-10		
D805	F-4	Q201	C-8		
D806	E-2	Q231	B-9		
D807	F-2	Q241	E-9		
D808	H-10	Q242	E-10		
		Q243	D-10		
IC81	I-14	Q501	B-4		
IC501	B-4	Q701	B-5		
IC541	E-9	Q702	B-6		
IC551	C-9 (TC-717M)	Q801	G-7		
IC551	D-13 (TC-717)	Q802	G-7		
IC701	E-7	Q803	H-9		
IC702	D-7	Q804	H-9		
IC801	G-8	Q805	H-9		
IC802	H-7	Q806	D-8		

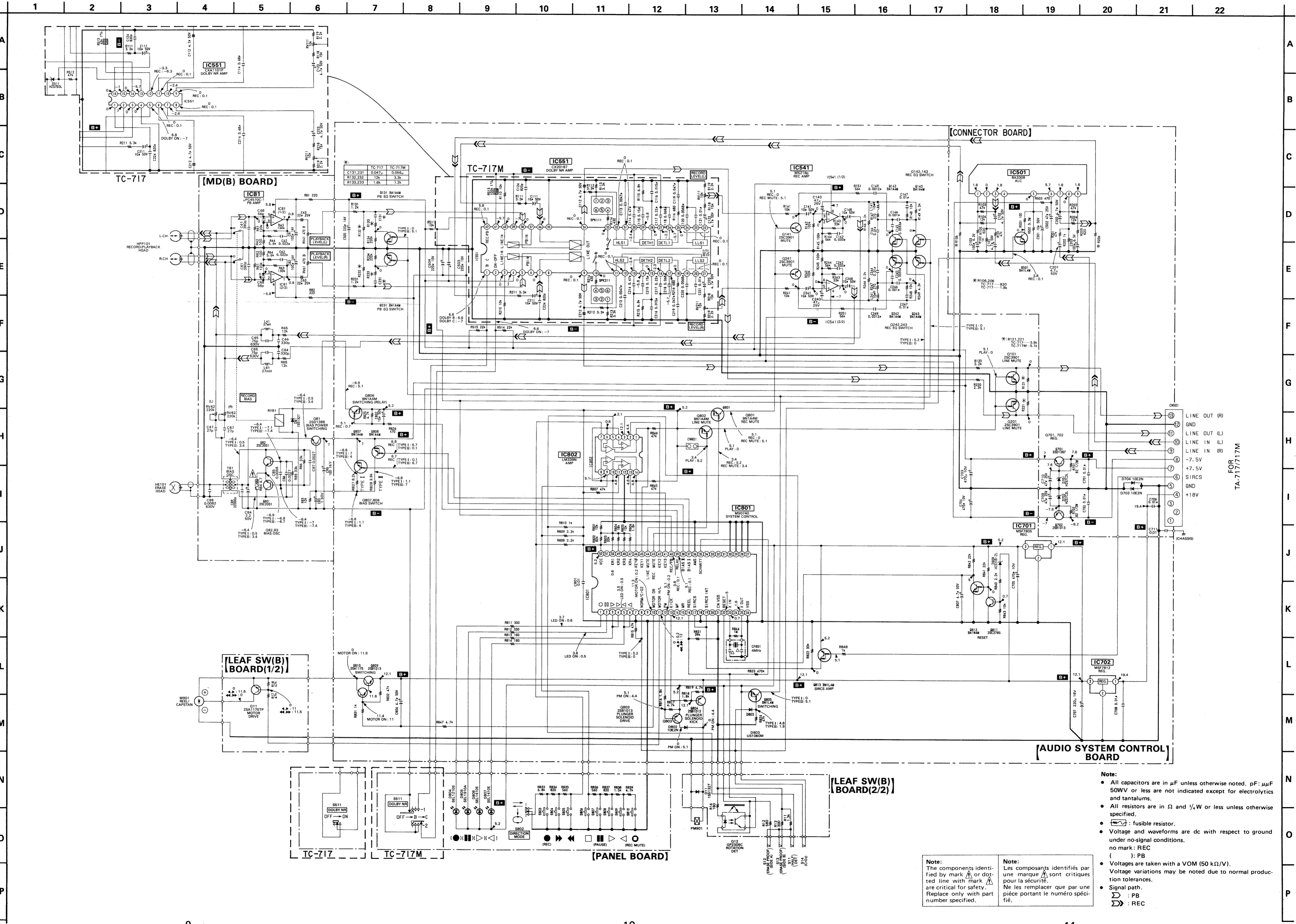

Note:
The components identified by mark Δ or dotted line with mark Δ are critical for safety. Replace only with part number specified.

Note:
Les composants identifiés par une marque Δ sont critiques pour la sécurité. Ne les remplacer que par une pièce portant le numéro spécifié.

- Note:**
- All capacitors are in μ F unless otherwise noted. pF: μ F 50WV or less are not indicated except for electrolytics and tantalums.
 - All resistors are in Ω and $1/4$ W or less unless otherwise specified.
 - $\text{---}/\text{---}$: fusible resistor.
 - Voltage and waveforms are dc with respect to ground under no-signal conditions. no mark: REC (): PB
 - Voltagés are taken with a VOM (50 k Ω /V). Voltage variations may be noted due to normal production tolerances.
 - Signal path. Σ : PB \gg : REC

SECTION 5 EXPLODED VIEWS

NOTE:

- The mechanical parts with no reference number in the exploded views are not supplied.
- The construction parts of an assembled part are indicated with a collation number in the remark column.
- Items marked "★" are not stocked since they are seldom required for routine service. Some delay should be anticipated when ordering these items.

- Due to standardization, parts with part number suffix -XX and -X may be different from the parts specified in the components used on the set.

- Color Indication of Appearance Parts**
 Example:
 (RED) ... KNOB, BALANCE (WHITE)
 ↑ ↑
 Cabinet's Color Parts' Color

The components identified by mark ▲ or dotted line with mark ▲ are critical for safety. Replace only with part number specified.

Les composants identifiés par une marque ▲ sont critiques pour la sécurité. Ne les remplacer que par une pièce portant le numéro spécifié.

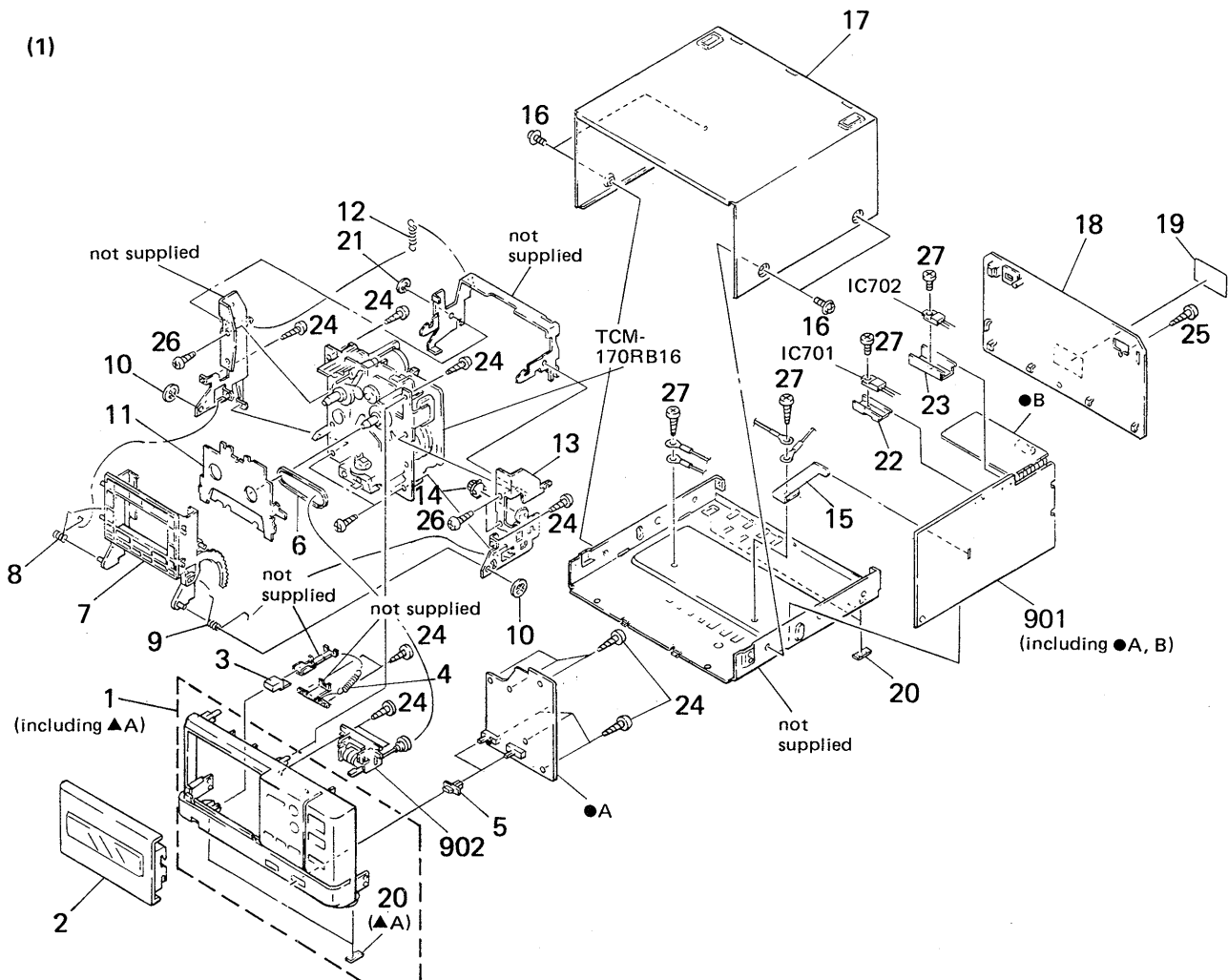

No.	Part No.	Description	Remarks	No.	Part No.	Description	Remarks
1	X-3352-801-1	(717)...PANEL ASSY, FRONT		17	4-930-355-01	(717M)...CASE	
	X-3352-804-1	(717M)...PANEL ASSY, FRONT			4-930-355-11	(717)...CASE	
2	X-3352-802-1	(717)...LID ASSY, CASSETTE		18	*3-352-815-01	PANEL, BACK	
	X-3352-805-1	(717M)...LID ASSY, CASSETTE		19	*3-352-801-01	(717M:US,Canadian,AEP,UK)	
3	3-352-810-01	BUTTON (EJECT)			*3-352-802-01	(717M:West Germany)...LABEL, MODEL NUMBER	
4	3-446-154-XX	SPRING, TENSION			*3-352-803-01	(717)...LABEL, MODEL NUMBER	
5	3-352-811-01	KNOB		20	4-930-336-01	FOOT (FELT)	
6	3-508-107-01	BELT, COUNTER		21	7-624-105-04	STOP RING 2.3, TYPE -E	
7	X-3343-628-1	HOLDER ASSY, CASSETTE		22	*3-309-144-21	HEAT SINK	
8	3-343-687-01	SPRING (LOADING LEFT)		23	*4-880-403-11	HEAT SINK	
9	3-343-688-01	SPRING (LOADING RIGHT)		24	7-685-133-19	SCREW +BTP 2.6X6 TYPE2 N-S	
10	7-624-190-31	STOP RING 4, TYPE-CS		25	7-685-647-79	SCREW +BVTP 3X10 TYPE2 N-S	
11	*3-352-809-01	RETAINER, CASSETTE		26	7-621-770-87	SCREW +BVTT 2.6X5 (S)	
12	3-343-689-01	SPRING, TENSION		27	7-682-547-04	SCREW +BVTT 3X6 (S)	
13	*X-3343-627-1	BRACKET (RB) ASSY		901	*A-2006-093-A	(717M)...MOUNTED PCB, SYSTEM CONTROL	
14	X-3332-464-1	GEAR (DAMPER) ASSY			*A-2006-094-A	(717)...MOUNTED PCB, SYSTEM CONTROL	
15	*3-327-845-01	BRACKET		902	1-548-596-41	COUNTER, TAPE (MIDDLE TYPE)	
16	3-704-366-01	SCREW (CASE) (M3X8)					

(2) TAPE TRANSPORT MECHANISM SECTION-1
(TCM-170RB16)

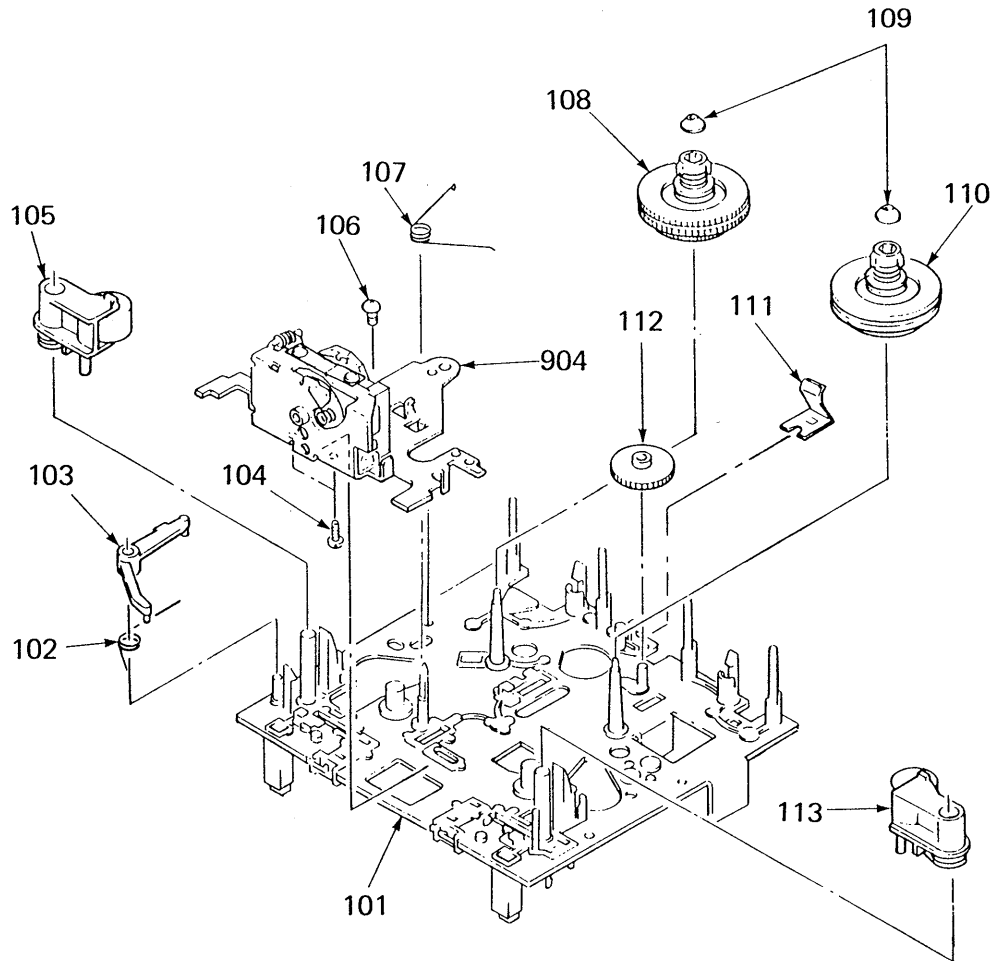

No.	Part No.	Description	Remarks	No.	Part No.	Description	Remarks
101	*X-3343-418-1	CHASSIS ASSY, MECHANICAL		109	3-343-439-01	CAP (REEL TABLE)	
102	3-343-477-01	SPRING, TORSION (EJECT SAFETY)		110	X-3343-401-1	TABEL ASSY, REEL	
103	*3-343-476-01	LEVER (EJECT SAFETY LEVER)		111	3-343-420-01	SPRING, LEAF	
104	7-685-102-19	SCREW +P 2X4 NON-SLIT TYPE 2		112	3-343-411-01	GEAR (FF GEAR)	
105	X-3343-403-1	LEVER (PINCH LEVER REV) ASSY		113	X-3343-402-1	LEVER (PINCH LEVER FWD) ASSY	
106	7-621-773-86	SCREW +BVTT 2.6X4 (S)		904	A-2108-130-A	CHASSIS ASSY, HEAD (HE901, HRP901)	
107	3-343-401-01	SPRING, TORSION					
108	X-3343-415-1	TABEL (REV) ASSY, REEL					

(3) TAPE TRANSPORT MECHANISM SECTION-2
(TCM-170RB16)

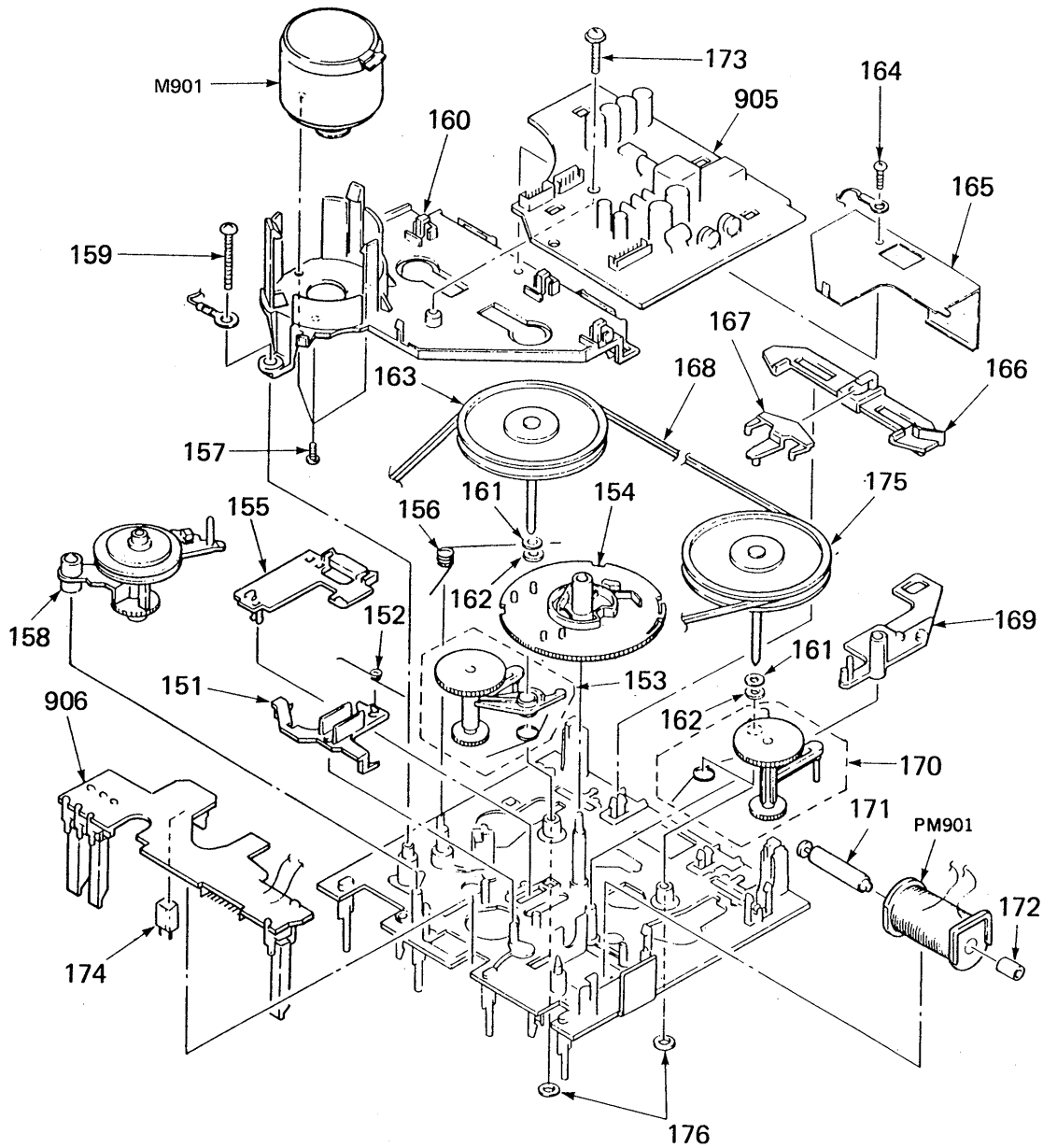

No.	Part No.	Description	Remarks	No.	Part No.	Description	Remarks
151	3-343-453-01	SLIDER (BRAKE PLATE)		166	*3-343-457-01	SLIDER (REVERSE SLIDER)	
152	3-343-429-01	SPRING, TORSION		167	3-343-462-01	LEVER	
153	X-3343-406-1	LEVER (TU ARM REV) ASSY		168	3-343-426-02	BELT (CAPSTAN BELT SQUARE)	
154	3-343-470-01	GEAR (CAM GEAR)		169	3-343-493-01	LEVER (PM LEVER)	
155	*3-343-461-01	SLIDER		170	X-3343-405-1	LEVER (TU ARM FWD) ASSY	
156	3-343-430-01	SPRING, TORSION		171	*3-343-425-01	ARBOR(MOVABLE IRON ARBOR),IRON	
157	7-627-556-28	SCREW +P 2.6X3.5		172	*3-343-424-01	ARBOR (FIXED IRON ARBOR), IRON	
158	X-3343-414-1	LAVER (FR ARM) ASSY		173	3-343-404-01	SCREW (PTPWH 2X10)	
159	3-343-403-01	SCREW (PTTWH 2X18)		174	*3-343-419-01	HOLDER (S SENSER A)	
160	*X-3343-407-1	BASE (THRUST RETAINER) ASSY		175	X-3343-431-1	FLYWHEEL (REV) COMPLETE ASSY	
161	4-605-835-11	WASHER (2.6), POLYSLIDER		176	3-343-473-01	WASHER, NYLON	
162	3-307-482-00	WASHER, LUMILER		M901	X-3343-408-1	MOTOR ASSY	
163	X-3343-429-1	FLYWHEEL COMPLETE ASSY		905	*1-625-912-14	PC BOARD, MD (B)	
164	7-685-104-19	SCREW +P 2X6 TYPE2 NON-SLIT		906	*1-624-148-11	PC BOARD, LEAF SW	
165	3-343-480-01	PLATE, SHIELD		PM901	1-454-456-11	SOLENOID, PLUNGER	

SECTION 6 ELECTRICAL PARTS LIST

NOTE:

- Due to standardization, replacements in the parts list may be different from the parts specified in the diagrams or the components used on the set.
- Items marked "★" are not stocked since they are seldom required for routine service. Some delay should be anticipated when ordering these items.
- If there are two or more same circuits in a set such as a stereophonic machine, only typical circuit parts may be indicated and capacitors and resistors in other same circuits may be omitted.

CAPACITORS:
MF: μ F, PF: μ MF.

RESISTORS
• All resistors are in ohms.
• F: nonflammable

COILS
• MMH: mH, UH: μ H

SEMICONDUCTORS
In each case, U: μ , for example:
UA...: μ A..., UPA...: μ PA...,
UPC...: μ PC, UPD...: μ PD...

The components identified by mark Δ or dotted line with mark Δ are critical for safety. Replace only with part number specified.

Les composants identifiés par une marque Δ sont critiques pour la sécurité. Ne les remplacer que par une pièce portant le numéro spécifié.

Ref.No.	Part No.	Description	Ref.No.	Part No.	Description
901	*A-2006-093-A	(717M)...MOUNTED PCB, SYSTEM CONTROL	C121	1-136-153-00	(717M)...FILM 0.01MF 5% 50V
	*A-2006-094-A	(717)...MOUNTED PCB, SYSTEM CONTROL	C123	1-124-927-11	ELECT 4.7MF 20% 50V
902	1-548-596-41	COUNTER, TAPE (MIDDLE TYPE)	C124	1-162-293-31	CERAMIC 820PF 10% 50V
904	A-2108-130-A	CHASSIS ASSY, HEAD (HE901,HRP901)	C131	1-136-162-00	(717M)...FILM 0.056MF 5% 50V
905	*1-625-912-14	PC BOARD, MD (B)	C141	1-123-875-11	ELECT 10MF 20% 50V
906	*1-624-148-11	PC BOARD, LEAF SW	C142	1-136-159-00	FILM 0.033MF 5% 50V
C41	1-110-342-11	MYLAR 390PF 5% 50V	C143	1-124-477-11	ELECT 47MF 20% 25V
C42	1-136-157-00	FILM 0.022MF 5% 50V	C144	1-136-153-00	FILM 0.01MF 5% 50V
C43	1-124-282-00	ELECT 22MF 20% 25V	C145	1-130-477-00	MYLAR 0.0033MF 5% 50V
C44	1-162-288-31	CERAMIC 330PF 10% 50V	C146	1-130-471-00	MYLAR 0.001MF 5% 50V
C45	1-136-273-91	FILM 75PF 5% 630V	C147	1-136-153-00	FILM 0.01MF 5% 50V
C47	1-162-209-31	CERAMIC 27PF 5% 50V	C148	1-123-875-11	ELECT 10MF 20% 50V
C48	1-162-217-31	CERAMIC 56PF 5% 50V	C149	1-130-472-00	MYLAR 0.0012MF 5% 50V
C61	1-110-342-11	MYLAR 390PF 5% 50V	C201	1-124-927-11	ELECT 4.7MF 20% 50V
C62	1-136-157-00	FILM 0.022MF 5% 50V	C202	1-124-927-11	ELECT 4.7MF 20% 50V
C63	1-124-282-00	ELECT 22MF 20% 25V	C203	1-124-443-00	ELECT 100MF 20% 6.3V
C64	1-162-288-31	CERAMIC 330PF 10% 50V	C211	1-123-875-11	ELECT 10MF 20% 50V
C65	1-136-273-91	FILM 75PF 5% 630V	C212	1-124-768-11	ELECT 4.7MF 20% 50V
C67	1-162-209-31	CERAMIC 27PF 5% 50V	C213	1-130-479-00	(717M)...MYLAR 0.0047MF 5% 50V
C68	1-162-217-31	CERAMIC 56PF 5% 50V	C214	1-136-173-00	(717M)...FILM 0.47MF 5% 50V
C81	1-126-101-11	ELECT 100MF 20% 16V	C214	1-136-175-00	(717)...FILM 0.68MF 5% 50V
C82	1-126-101-11	ELECT 100MF 20% 16V	C215	1-136-167-00	(717M)...FILM 0.15MF 5% 50V
C83	1-124-499-11	ELECT 1MF 20% 50V	C216	1-136-155-00	(717M)...FILM 0.015MF 5% 50V
C84	1-124-925-11	ELECT 2.2MF 20% 50V	C217	1-136-169-00	(717M)...FILM 0.22MF 5% 50V
C85	1-130-480-00	MYLAR 0.0056MF 5% 50V	C218	1-136-163-00	(717M)...FILM 0.068MF 5% 50V
C86	1-130-476-00	MYLAR 0.0027MF 5% 50V	C219	1-136-161-00	FILM 0.047MF 5% 50V
C87	1-130-476-00	MYLAR 0.0027MF 5% 50V	C220	1-130-481-00	(717M)...MYLAR 0.0068MF 5% 50V
C88	1-136-562-11	FILM 0.0082MF 5% 630V	C221	1-136-153-00	(717M)...FILM 0.01MF 5% 50V
C89	1-161-494-00	CERAMIC 0.022MF 25V	C223	1-124-927-11	ELECT 4.7MF 20% 50V
C90	1-126-101-11	ELECT 100MF 20% 16V	C224	1-162-293-31	CERAMIC 820PF 10% 50V
C101	1-124-927-11	ELECT 4.7MF 20% 50V	C231	1-136-162-00	(717M)...FILM 0.056MF 5% 50V
C102	1-124-927-11	ELECT 4.7MF 20% 50V	C241	1-123-875-11	ELECT 10MF 20% 50V
C103	1-124-443-00	ELECT 100MF 20% 6.3V	C242	1-136-159-00	FILM 0.033MF 5% 50V
C111	1-123-875-11	ELECT 10MF 20% 50V	C243	1-124-477-11	ELECT 47MF 20% 25V
C112	1-124-768-11	ELECT 4.7MF 20% 50V	C244	1-136-153-00	FILM 0.01MF 5% 50V
C113	1-130-479-00	(717M)...MYLAR 0.0047MF 5% 50V	C245	1-130-477-00	MYLAR 0.0033MF 5% 50V
C114	1-136-173-00	(717M)...FILM 0.47MF 5% 50V	C246	1-130-471-00	MYLAR 0.001MF 5% 50V
C114	1-136-175-00	(717)...FILM 0.68MF 5% 50V	C247	1-136-153-00	FILM 0.01MF 5% 50V
C115	1-136-167-00	(717M)...FILM 0.15MF 5% 50V	C248	1-123-875-11	ELECT 10MF 20% 50V
C116	1-136-155-00	(717M)...FILM 0.015MF 5% 50V	C249	1-130-472-00	MYLAR 0.0012MF 5% 50V
C117	1-136-169-00	(717M)...FILM 0.22MF 5% 50V	C501	1-123-875-11	ELECT 10MF 20% 50V
C118	1-136-163-00	(717M)...FILM 0.068MF 5% 50V	C502	1-124-477-11	ELECT 47MF 20% 25V
C119	1-136-161-00	FILM 0.047MF 5% 50V	C503	1-126-176-11	ELECT 220MF 20% 10V
C120	1-130-481-00	(717M)...MYLAR 0.0068MF 5% 50V	C504	1-126-176-11	ELECT 220MF 20% 10V
			C505	1-124-120-11	ELECT 220MF 20% 16V

Ref.No.	Part No.	Description			
C701	1-136-153-00	FILM	0.01MF	5%	50V
C702	1-136-153-00	FILM	0.01MF	5%	50V
C703	1-124-472-11	ELECT	47OMF	20%	10V
C704	1-124-472-11	ELECT	47OMF	20%	10V
C705	1-124-472-11	ELECT	47OMF	20%	10V
C706	1-136-153-00	FILM	0.01MF	5%	50V
C707	1-124-120-11	ELECT	22OMF	20%	16V
C708	1-136-153-00	FILM	0.01MF	5%	50V
C709	1-124-477-11	ELECT	47MF	20%	25V
C710	1-124-477-11	ELECT	47MF	20%	25V
C711	1-161-379-00	CERAMIC	0.01MF	30%	25V
C801	1-161-379-00	CERAMIC	0.01MF	30%	16V
C802	1-123-875-11	ELECT	10MF	20%	50V
C806	1-124-927-11	ELECT	4.7MF	20%	50V
C807	1-124-927-11	ELECT	4.7MF	20%	50V
CF801	1-577-082-11	VIBRATOR, CERAMIC			
CN501	*1-565-291-11	SOCKET, CONNECTOR 13P			
CN801	*1-560-060-00	PIN, CONNECTOR 2P			
CN802	*1-564-338-00	PIN, CONNECTOR 4P			
CN803	*1-564-341-11	PIN, CONNECTOR 7P			
CNP11	*1-564-501-11	PIN, CONNECTOR 8P			
CNP12	*1-564-337-00	PIN, CONNECTOR 3P			
CNP13	*1-564-707-11	PIN, CONNECTOR (SMALL TYPE) 5P			
CNP81	*1-564-709-11	PIN, CONNECTOR (SMALL TYPE) 7P			
CNP82	*1-564-339-00	PIN, CONNECTOR 5P			
CNP83	*1-564-338-00	PIN, CONNECTOR 4P			
D11	8-719-940-76	DIODE 1SS132			
D81	8-719-940-76	DIODE 1SS132			
D511	8-719-933-48	(717)...ZENER DIODE HZS7B3L			
D701	8-719-000-96	DIODE UZL-7H2			
D702	8-719-000-96	DIODE UZL-7H2			
D703	8-719-200-77	DIODE 10E2N			
D704	8-719-200-77	DIODE 10E2N			
D802	8-719-200-77	DIODE 10E2N			
D803	8-719-000-26	DIODE US1060M			
D804	8-719-302-45	LED SEL1210S			
D805	8-719-941-46	LED GL-5HY41			
D806	8-719-302-52	LED SEL1410E			
D807	8-719-302-52	LED SEL1410E			
D808	8-719-934-71	ZENER DIODE HZS11B-2L			
IC81	8-759-111-44	IC UPC4570C-1			
IC501	8-759-939-73	IC BA3308			
IC541	8-759-601-02	IC M5218P			
IC551	8-752-018-70	(717M)...IC CX20187			
IC551	8-752-031-83	(717)...IC CXA1101P			

Ref.No.	Part No.	Description			
IC701	8-759-604-29	IC M5F7805			
IC702	8-759-604-33	IC M5F7812			
IC801	8-759-632-51	IC M50740-108SP			
IC802	8-759-984-03	IC LM339N			
L41	1-410-780-11	INDUCTOR	27MMH		
L61	1-410-780-11	INDUCTOR	27MMH		
L141	1-410-775-21	INDUCTOR	10MMH		
L241	1-410-775-21	INDUCTOR	10MMH		
M901	X-3343-408-1	MOTOR ASSY			
PM901	1-454-456-11	SOLENOID, PLUNGER			
Q11	8-729-119-76	TRANSISTOR 2SA1175-HFE			
Q12	8-719-939-23	PHOTO TRANSISTOR GP2S09-C			
Q81	8-729-111-29	TRANSISTOR 2SD1388			
Q82	8-729-100-13	TRANSISTOR 2SC2001			
Q83	8-729-100-13	TRANSISTOR 2SC2001			
Q101	8-729-806-26	TRANSISTOR 2SC3901			
Q131	8-729-115-79	TRANSISTOR BA1A4M			
Q141	8-729-806-26	TRANSISTOR 2SC3901			
Q142	8-729-115-79	TRANSISTOR BA1A4M			
Q143	8-729-115-79	TRANSISTOR BA1A4M			
Q201	8-729-806-26	TRANSISTOR 2SC3901			
Q231	8-729-115-79	TRANSISTOR BA1A4M			
Q241	8-729-806-26	TRANSISTOR 2SC3901			
Q242	8-729-115-79	TRANSISTOR BA1A4M			
Q243	8-729-115-79	TRANSISTOR BA1A4M			
Q501	8-729-115-77	TRANSISTOR BA1L4M			
Q701	8-729-801-93	TRANSISTOR 2SD1387			
Q702	8-729-801-83	TRANSISTOR 2SB1013			
Q801	8-729-115-15	TRANSISTOR BN1A4M			
Q802	8-729-115-15	TRANSISTOR BN1A4M			
Q803	8-729-801-83	TRANSISTOR 2SB1013			
Q804	8-729-801-83	TRANSISTOR 2SB1013			
Q805	8-729-115-12	TRANSISTOR BN1L4M			
Q806	8-729-115-15	TRANSISTOR BN1A4M			
Q807	8-729-115-15	TRANSISTOR BN1A4M			
Q808	8-729-115-15	TRANSISTOR BN1A4M			
Q809	8-729-801-83	TRANSISTOR 2SB1013			
Q810	8-729-173-38	TRANSISTOR 2SA733			
Q811	8-729-119-78	TRANSISTOR 2SC2785			
Q812	8-729-115-77	TRANSISTOR BA1L4M			
Q813	8-729-900-63	TRANSISTOR DTA124ES			
R11	1-247-834-11	CARBON	1.3K	5%	1/4W
R12	1-249-414-11	CARBON	560	5%	1/4W
R13	1-247-818-11	CARBON	300	5%	1/4W
R14	1-249-408-11	CARBON	180	5%	1/4W
R17	1-249-437-11	CARBON	47K	5%	1/4W
R18	1-249-437-11	CARBON	47K	5%	1/4W

Ref.No.	Part No.	Description				
R41	1-247-881-00	CARBON	120K	5%	1/4W	
R42	1-249-405-11	CARBON	100	5%	1/4W	
R43	1-247-882-11	CARBON	130K	5%	1/4W	
R44	1-249-426-11	CARBON	5.6K	5%	1/4W	
R45	1-249-430-11	CARBON	12K	5%	1/4W	
R61	1-247-881-00	CARBON	120K	5%	1/4W	
R62	1-249-405-11	CARBON	100	5%	1/4W	
R63	1-247-882-11	CARBON	130K	5%	1/4W	
R64	1-249-426-11	CARBON	5.6K	5%	1/4W	
R65	1-249-430-11	CARBON	12K	5%	1/4W	
R81	1-249-409-11	CARBON	220	5%	1/4W	
R82	1-249-409-11	CARBON	220	5%	1/4W	
R83	1-249-429-11	CARBON	10K	5%	1/4W	
R84	▲ 1-212-849-00	FUSIBLE	4.7	5%	1/4W	F
R85	1-249-435-11	CARBON	33K	5%	1/4W	
R86	1-249-435-11	CARBON	33K	5%	1/4W	
R101	1-249-437-11	CARBON	47K	5%	1/4W	
R102	1-249-417-11	CARBON	1K	5%	1/4W	
R103	1-249-437-11	CARBON	47K	5%	1/4W	
R104	1-249-430-11	CARBON	12K	5%	1/4W	
R105	1-247-826-00	CARBON	620	5%	1/4W	
R106	1-249-416-11	(717)...CARBON	820	5%	1/4W	
R106	1-249-420-11	(717M)...CARBON	1.8K	5%	1/4W	
R110	1-249-429-11	(717M)...CARBON	10K	5%	1/4W	
R111	1-249-423-11	CARBON	3.3K	5%	1/4W	
R112	1-249-423-11	(717M)...CARBON	3.3K	5%	1/4W	
R113	1-249-423-11	(717M)...CARBON	3.3K	5%	1/4W	
R114	1-247-822-11	(717M)...CARBON	430	5%	1/4W	
R115	1-249-427-11	(717M)...CARBON	6.8K	5%	1/4W	
R116	1-249-415-11	(717M)...CARBON	680	5%	1/4W	
R118	1-249-431-11	CARBON	15K	5%	1/4W	
R119	1-249-421-11	CARBON	2.2K	5%	1/4W	
R120	1-249-421-11	CARBON	2.2K	5%	1/4W	
R121	1-247-848-11	(717M)...CARBON	5.1K	5%	1/4W	
R121	1-249-424-11	(717)...CARBON	3.9K	5%	1/4W	
R131	1-249-418-11	CARBON	1.2K	5%	1/4W	
R132	1-249-423-11	(717M)...CARBON	3.3K	5%	1/4W	
R132	1-249-430-11	(717)...CARBON	12K	5%	1/4W	
R133	1-247-836-11	(717)...CARBON	1.6K	5%	1/4W	
R133	1-249-418-11	(717M)...CARBON	1.2K	5%	1/4W	
R134	1-247-887-00	CARBON	220K	5%	1/4W	
R141	1-249-429-11	CARBON	10K	5%	1/4W	
R142	1-249-441-11	CARBON	100K	5%	1/4W	

Ref.No.	Part No.	Description				
R143	1-249-435-11	CARBON	33K	5%	1/4W	
R144	1-249-438-11	CARBON	56K	5%	1/4W	
R145	1-249-441-11	CARBON	100K	5%	1/4W	
R146	1-249-421-11	CARBON	2.2K	5%	1/4W	
R147	1-249-410-11	CARBON	270	5%	1/4W	
R148	1-249-429-11	CARBON	10K	5%	1/4W	
R149	1-247-846-11	CARBON	4.3K	5%	1/4W	
R151	1-249-438-11	CARBON	56K	5%	1/4W	
R201	1-249-437-11	CARBON	47K	5%	1/4W	
R202	1-249-417-11	CARBON	1K	5%	1/4W	
R203	1-249-437-11	CARBON	47K	5%	1/4W	
R204	1-249-430-11	CARBON	12K	5%	1/4W	
R205	1-247-826-00	CARBON	620	5%	1/4W	
R206	1-249-416-11	(717)...CARBON	820	5%	1/4W	
R206	1-249-420-11	(717M)...CARBON	1.8K	5%	1/4W	
R210	1-249-429-11	(717M)...CARBON	10K	5%	1/4W	
R211	1-249-423-11	CARBON	3.3K	5%	1/4W	
R212	1-249-423-11	(717M)...CARBON	3.3K	5%	1/4W	
R213	1-249-423-11	(717M)...CARBON	3.3K	5%	1/4W	
R214	1-247-822-11	(717M)...CARBON	430	5%	1/4W	
R215	1-249-427-11	(717M)...CARBON	6.8K	5%	1/4W	
R216	1-249-415-11	(717M)...CARBON	680	5%	1/4W	
R218	1-249-431-11	CARBON	15K	5%	1/4W	
R219	1-249-421-11	CARBON	2.2K	5%	1/4W	
R220	1-249-421-11	CARBON	2.2K	5%	1/4W	
R221	1-247-848-11	(717M)...CARBON	5.1K	5%	1/4W	
R221	1-249-424-11	(717)...CARBON	3.9K	5%	1/4W	
R231	1-249-418-11	CARBON	1.2K	5%	1/4W	
R232	1-249-423-11	(717M)...CARBON	3.3K	5%	1/4W	
R232	1-249-430-11	(717)...CARBON	12K	5%	1/4W	
R233	1-249-418-11	(717M)...CARBON	1.2K	5%	1/4W	
R233	1-247-836-11	(717)...CARBON	1.6K	5%	1/4W	
R234	1-247-887-00	CARBON	220K	5%	1/4W	
R241	1-249-429-11	CARBON	10K	5%	1/4W	
R242	1-249-441-11	CARBON	100K	5%	1/4W	
R243	1-249-435-11	CARBON	33K	5%	1/4W	
R244	1-249-438-11	CARBON	56K	5%	1/4W	
R245	1-249-441-11	CARBON	100K	5%	1/4W	
R246	1-249-421-11	CARBON	2.2K	5%	1/4W	
R247	1-249-410-11	CARBON	270	5%	1/4W	
R248	1-249-429-11	CARBON	10K	5%	1/4W	
R249	1-247-846-11	CARBON	4.3K	5%	1/4W	
R251	1-249-438-11	CARBON	56K	5%	1/4W	
R501	1-249-405-11	CARBON	100	5%	1/4W	

<p>Note: The components identified by mark ▲ or dotted line with mark ▲ are critical for safety. Replace only with part number specified.</p>	<p>Note: Les composants identifiés par une marque ▲ sont critiques pour la sécurité. Ne les remplacer que par une pièce portant le numéro spécifié.</p>
--	--

Ref.No.	Part No.	Description				
R502	1-259-882-81	CARBON	3.3M	5%	1/4W	
R503	1-249-413-11	CARBON	470	5%	1/4W	
R511	1-249-429-11	CARBON	10K	5%	1/4W	
R512	1-249-437-11	(717)...CARBON	47K	5%	1/4W	
R513	1-215-460-00	(717)...METAL	43K	1%	1/6W	
R513	1-215-469-00	(717M)...METAL	100K	1%	1/6W	
R514	1-249-433-11	CARBON	22K	5%	1/4W	
R515	1-249-433-11	(717M)...CARBON	22K	5%	1/4W	
R701	1-247-738-11	CARBON	82	5%	1/2W	
R702	1-247-738-11	CARBON	82	5%	1/2W	
R801	1-249-429-11	CARBON	10K	5%	1/4W	
R802	1-249-440-11	CARBON	82K	5%	1/4W	
R803	1-249-435-11	CARBON	33K	5%	1/4W	
R804	1-249-432-11	CARBON	18K	5%	1/4W	
R805	1-249-429-11	CARBON	10K	5%	1/4W	
R806	1-249-420-11	CARBON	1.8K	5%	1/4W	
R807	1-249-437-11	CARBON	47K	5%	1/4W	
R808	1-249-421-11	CARBON	2.2K	5%	1/4W	
R809	1-249-421-11	CARBON	2.2K	5%	1/4W	
R810	1-249-417-11	CARBON	1K	5%	1/4W	
R811	1-249-411-11	CARBON	330	5%	1/4W	
R812	1-249-411-11	CARBON	330	5%	1/4W	
R813	1-249-408-11	CARBON	180	5%	1/4W	
R814	1-249-408-11	CARBON	180	5%	1/4W	
R815	1-249-437-11	CARBON	47K	5%	1/4W	
R816	1-249-420-11	CARBON	1.8K	5%	1/4W	
R817	1-249-425-11	CARBON	4.7K	5%	1/4W	
R818	1-249-420-11	CARBON	1.8K	5%	1/4W	
R819	1-249-425-11	CARBON	4.7K	5%	1/4W	
R821	1-249-436-11	CARBON	39K	5%	1/4W	
R822	1-249-435-11	CARBON	33K	5%	1/4W	
R823	1-247-895-00	CARBON	470K	5%	1/4W	
R824	1-249-437-11	CARBON	47K	5%	1/4W	
R825	1-249-425-11	CARBON	4.7K	5%	1/4W	
R826	1-249-413-11	CARBON	470	5%	1/4W	
R827	1-247-850-11	CARBON	6.2K	5%	1/4W	
R828	1-249-421-11	CARBON	2.2K	5%	1/4W	
R831	1-249-417-11	CARBON	1K	5%	1/4W	
R832	1-249-437-11	CARBON	47K	5%	1/4W	
R833	1-249-427-11	CARBON	6.8K	5%	1/4W	
R834	1-249-416-11	CARBON	820	5%	1/4W	
R835	1-249-414-11	CARBON	560	5%	1/4W	
R836	1-249-414-11	CARBON	560	5%	1/4W	
R837	1-249-416-11	CARBON	820	5%	1/4W	
R838	1-249-419-11	CARBON	1.5K	5%	1/4W	

Ref.No.	Part No.	Description				
R839	1-249-425-11	CARBON	4.7K	5%	1/4W	
R840	1-249-421-11	CARBON	2.2K	5%	1/4W	
R841	1-249-433-11	CARBON	22K	5%	1/4W	
R842	1-249-433-11	CARBON	22K	5%	1/4W	
R843	1-249-429-11	CARBON	10K	5%	1/4W	
R844	1-247-903-00	CARBON	1M	5%	1/4W	
R845	1-249-437-11	CARBON	47K	5%	1/4W	
R846	1-249-437-11	CARBON	47K	5%	1/4W	
R847	1-249-425-11	CARBON	4.7K	5%	1/4W	
R848	1-249-417-11	CARBON	1K	5%	1/4W	
RV41	1-228-989-00	RES, ADJ, CARBON	470			
RV42	1-230-500-11	RES, ADJ, CARBON	220K			
RV61	1-228-989-00	RES, ADJ, CARBON	470			
RV62	1-230-500-11	RES, ADJ, CARBON	220K			
RV111	1-228-994-00	RES, ADJ, CARBON	10K			
RV211	1-228-994-00	RES, ADJ, CARBON	10K			
RY81	1-515-614-11	RELAY				
S11	1-571-281-21	SWITCH, LEAF				
S12	1-571-281-21	SWITCH, LEAF				
S13	1-571-281-21	SWITCH, LEAF				
S14	1-571-281-21	SWITCH, LEAF				
S511	1-570-157-21	(717)...SWITCH, SLIDE (DOLBY ON/OFF)				
S511	1-571-908-11	(717M)...SWITCH, SLIDE (DOLBY OFF/B/C)				
S802	1-570-157-21	SWITCH, SLIDE (DIRECTION MODE)				
S803	1-554-303-21	SWITCH, KEY BOARD (●)				
S804	1-554-303-21	SWITCH, KEY BOARD (▶)				
S805	1-554-303-21	SWITCH, KEY BOARD (◀)				
S806	1-554-303-21	SWITCH, KEY BOARD (□)				
S807	1-554-303-21	SWITCH, KEY BOARD ()				
S808	1-554-303-21	SWITCH, KEY BOARD (▷)				
S809	1-554-303-21	SWITCH, KEY BOARD (◁)				
S810	1-554-303-21	SWITCH, KEY BOARD (○)				
SPK111	1-235-186-00	(717M)...ENCAPSULATED COMPONENT				
SPK211	1-235-186-00	(717M)...ENCAPSULATED COMPONENT				
T81	1-433-337-11	TRANSFORMER, BIAS OSCILLATION				