

# TC-756/TC-756-2

USA Model

AEP Model

UK Model

USA Model



## STEREO TAPECORDER

### SPECIFICATIONS

<b>Power Requirements:</b>	AC 120 V, 60 Hz, 100 W (USA) AC 110, 127, 220 or 240 V, 50/60 Hz, 110 W (AEP, UK)	<b>Inputs:</b>	MIC (2) Impedance: low Maximum sensitivity: -72 dB (0.19 mV)
<b>Track System:</b>	TC-756: 4-track 2-channel stereo TC-756-2: 2-track 2-channel stereo	<b>LINE IN (2)</b>	Impedance: 100 k $\Omega$ Maximum sensitivity: -72 dB (80 mV)
<b>Reels:</b>	270 mm (10 1/2 inches) or smaller	<b>LINE OUT (2)</b>	Impedance: 100 k $\Omega$ Level: -5 dB (0.44 V) with 100 k $\Omega$ load
<b>Tape Speed:</b>	19 cm/s (7 1/2 ips), 38 cm/s (15 ips)	<b>HEADPHONE</b>	Impedance: 8 $\Omega$
<b>Recording Time:</b>	With 1,100 m (3936 ft.) tape of 270 mm (10 1/2 inch) reel TC-756: 3-hours stereo recording at 19 cm/s (7 1/2 ips) TC-756-2: 1.5-hours stereo recording at 19 cm/s (7 1/2 ips)	<b>REC/PA Connector</b>	(AEP, UK): Input impedance: 3.9 k $\Omega$ Output impedance: 8.2 k $\Omega$
<b>Frequency Response</b> (With SONY SLH tape)	20-25,000 Hz $\pm$ 3 dB at 38 cm/s (15 ips) 20-30,000 Hz $\pm$ 3 dB at 19 cm/s (7 1/2 ips) 30-25,000 Hz $\pm$ 3 dB at 19 cm/s (7 1/2 ips)	<b>AC Outlet (USA):</b>	Unswitched, 300 W maximum
<b>Signal-to-Noise Ratio:</b>	TC-756: 56 dB (Sony SLH tape) 53 dB (standard tape) TC-756-2: 59 dB (Sony SLH tape) 56 dB (standard tape)	<b>Heads:</b>	TC-756 TC-756-2 Record : RF140-2907 RF142-2202A Playback : PF142-4202 PF142-2202A Erase : EF18-2902A? EF85-2202
<b>Wow and Flutter:</b>	0.04 % (RMS) weighted at 38 cm/s (15 ips) 0.06 % (RMS) weighted at 19 cm/s (7 1/2 ips)	<b>Motors:</b>	Capstan: IC-6246 (AC servo controlled) Reel: IC-638R (2)
<b>Overall Distortion:</b>	1.2 %	<b>Semiconductors:</b>	1 IC, 2 FETs, 58 transistors, 46 diodes
<b>Record Bias Frequency:</b>	Approximately 160 kHz	<b>Dimensions:</b>	435 (w) x 451 (h) x 221 (d) mm 17 1/4 (w) x 17 3/4 (h) x 8 3/4 (d) inches
		<b>Weight:</b>	24 kg, 52 lb 14 oz

**SONY**  
SERVICE MANUAL

## TABLE OF CONTENTS

<u>Section</u>	<u>Title</u>	<u>Page</u>
	Specifications .....	1
<b>1.</b>	<b>OUTLINE</b>	
	1-1. Block Diagrams .....	3
	1-2. External View .....	4
	1-3. Internal View (1) .....	4
	1-4. Internal View (2) .....	5
	1-5. Internal View (3) .....	5
	1-6. Internal View (4) .....	5
	1-7. Notes on Operation .....	6
	1-8. Notes on Repair .....	7
<b>2.</b>	<b>ADJUSTMENTS</b>	
	2-1. Mechanical Adjustments .....	8
	2-2. Electrical Adjustments .....	16
<b>3.</b>	<b>DIAGRAMS</b>	
	3-1 (A). Level Diagrams (TC-756-2) .....	26
	3-1 (B). Level Diagrams (TC-756) .....	62
	3-2. Schematic Diagram – Amp Section – .....	27
	3-3. Mounting Diagram – Amp Section – .....	29
	3-4. Mounting Diagram – System Control Section – .....	32
	3-5. Schematic Diagram – System Control Section – .....	35
<b>4.</b>	<b>EXPLODED VIEWS AND PACKING</b>	
	4-1. Exploded View (1) .....	37
	4-2. Exploded View (2) .....	39
	4-3. Exploded View (3) .....	41
	4-4. Exploded View (4) .....	43
	4-5. Exploded View (5) .....	45
	4-6. Exploded View (6) .....	46
	4-7. Exploded View (7) .....	47
	4-8. Exploded View (8) .....	49
	4-9. Exploded View (9) .....	51
	4-10. Exploded View (10) .....	53
	4-11. Packing .....	55
<b>5.</b>	<b>ELECTRICAL PARTS LIST</b> .....	56
<b>6.</b>	<b>HARDWARE</b> .....	61

*When ordering replacement parts, use PART NUMBERS listed in Parts Lists or shown in EXPLODED VIEWS.*

*Parts List reference numbers should not be used.*

### MODEL IDENTIFICATION

(See specification label.)

<i>Model</i>	<i>Identification on specification label</i>
USA	AC 120V 60 Hz 100W SUPERSCOPE
AEP, UK	110, 127, 220, 240V ~ 50/60 Hz 110W

# TC-756/TC-756-2

## SECTION 1 DIAGRAMS

### 1-1. BLOCK DIAGRAMS

#### Amp Section

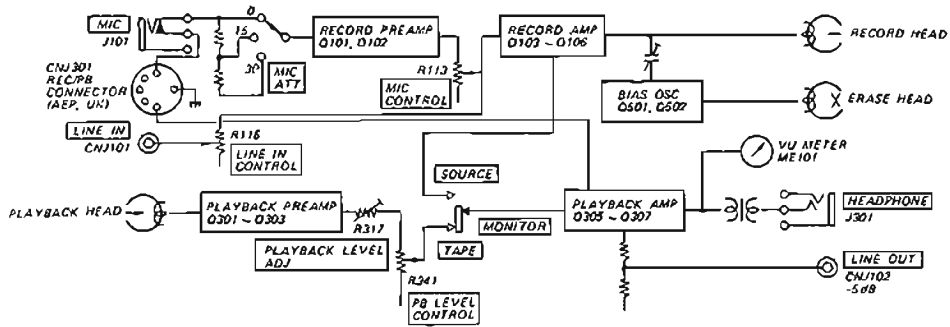

#### System Control Section

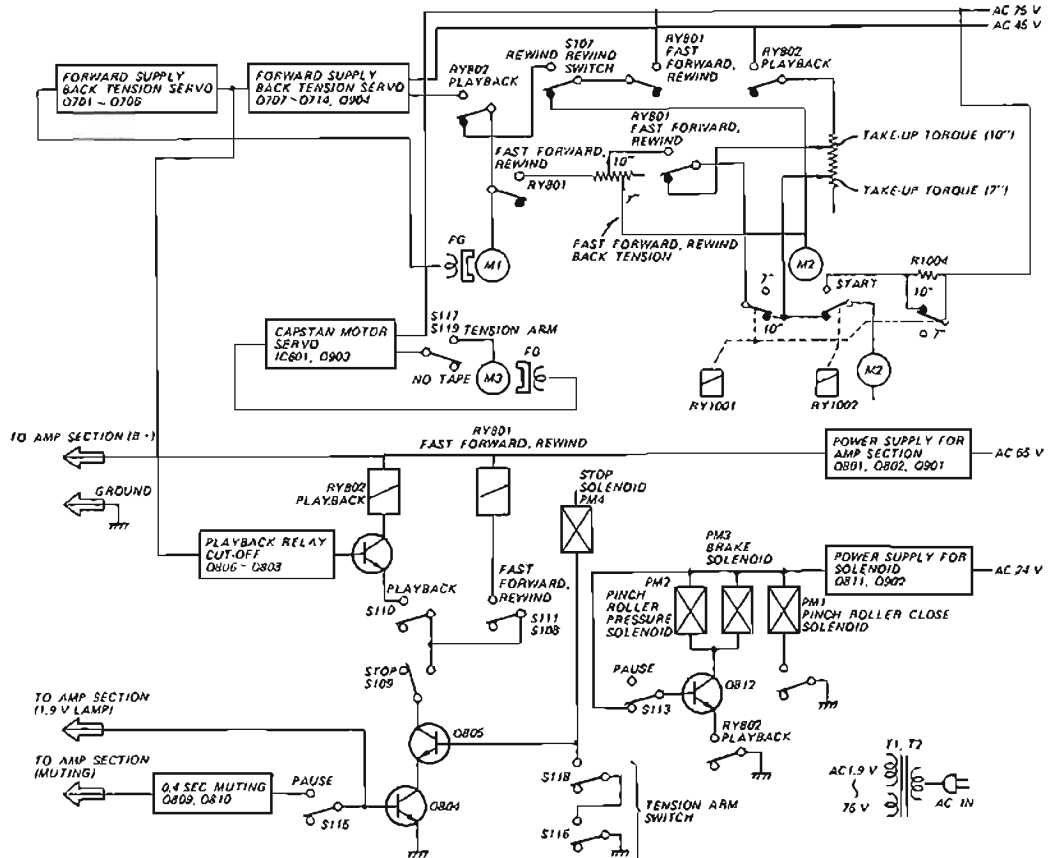

1-2. EXTERNAL VIEW

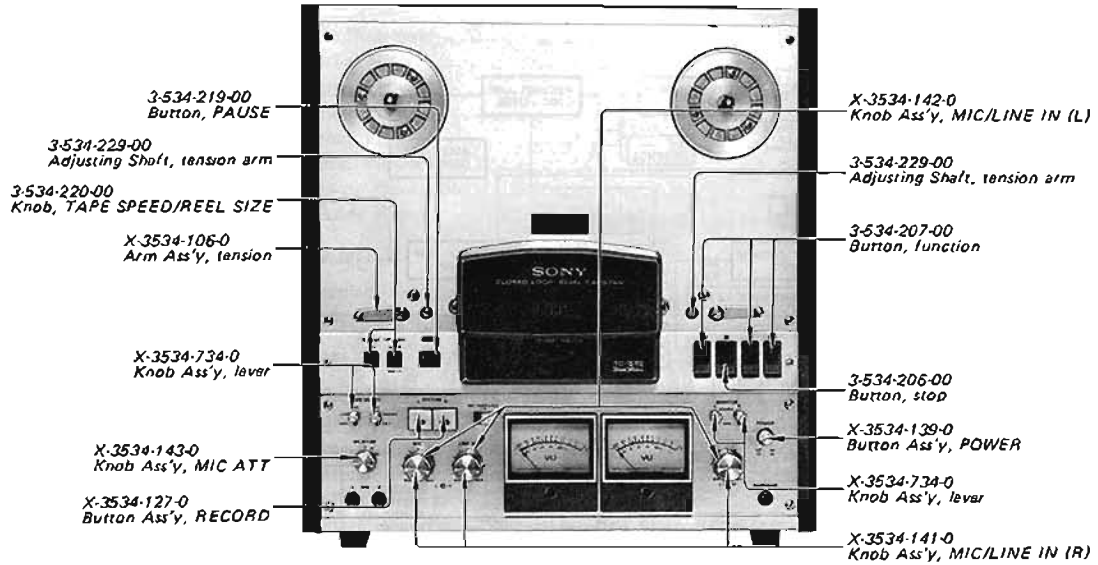

1-3. INTERNAL VIEW (1)

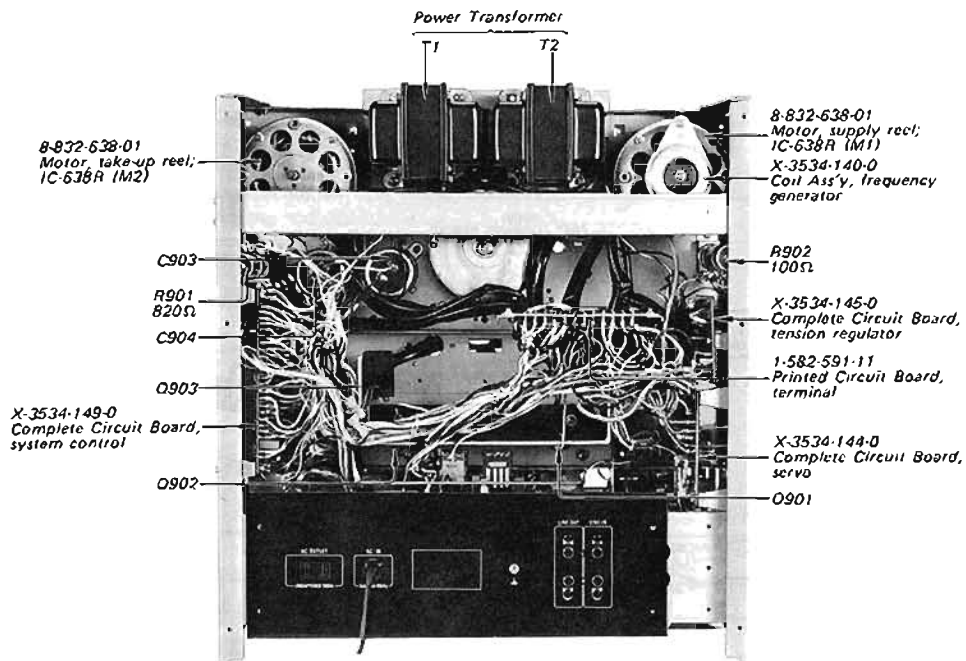

1-4. INTERNAL VIEW (2)

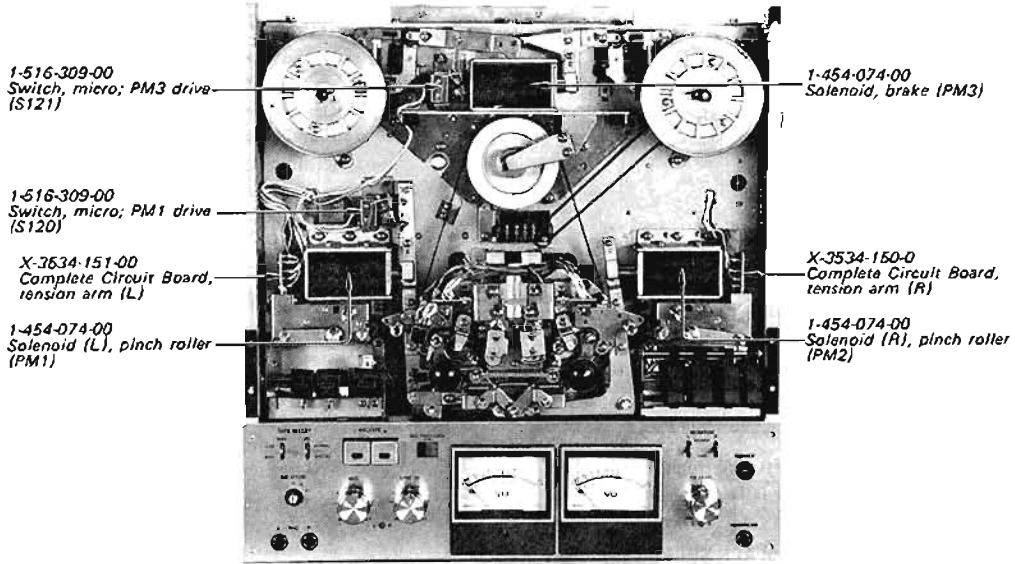

1-5. INTERNAL VIEW (3)

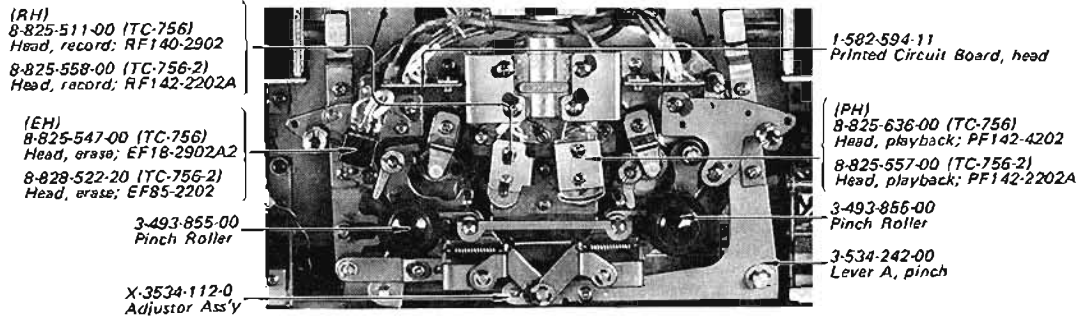

1-6. INTERNAL VIEW (4)

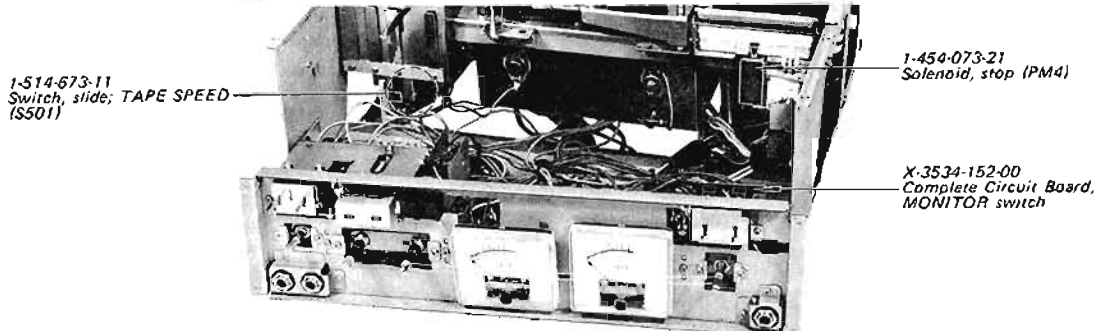

### 1-7. NOTES ON OPERATION

1. For 270 mm (10½ inch) metal reel, use a reel spacer and a Sony Reel Adaptor RAD-10.
2. Thread a tape as illustrated. Be sure to pass the tape under the tension-arm guides, and above the tape guides.

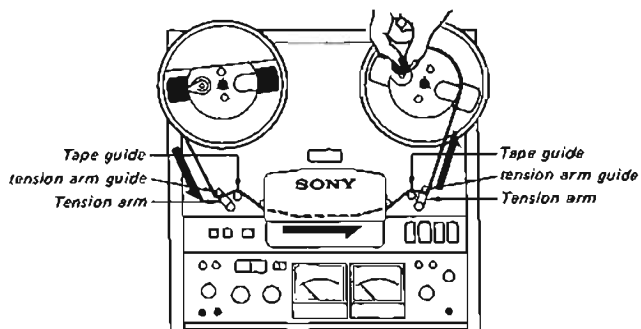

3. For protection against the high bias voltage the upper head cover is fastened with the two head cover bosses.
4. Set the BIAS and EQ (TAPE SELECT) switches according to the tape used.

BIAS switch	EQ switch	Tapes
LOW	NORMAL	SONY SUPER 150, SUPER A TDK 150 SCOTCH 150 Other 150 type tapes
LOW	SPECIAL	SONY SLH MAXELL LNE 35 AGFA PE 35 BASF LP 35, 35LH
HIGH	NORMAL	SCOTCH 203, 206 TDK SD 150
HIGH	SPECIAL	When using some tapes, frequency response range may be wide but distortion level may be high.

5. Do not leave the TC-756-2 in PAUSE mode for a long time, since the normal rated voltages are still applied to the reel motors in PAUSE mode. Place the TC-756-2 in stop mode instead.
6. REC TIMER LOCK button can be moved to the right only when L and/or R RECORD buttons are pushed in stop mode. Once the RECORD buttons are locked, they cannot be released and remain illuminated even though any function button (stop, fast forward, rewind or forward button) is pushed. The TC-756-2 can be placed in record mode only by pushing the forward button, but not by pushing the stop, fast forward or rewind button.
7. Before setting the timer-activated recording, be sure to turn POWER switch OFF. Otherwise the tension arms may be turned OFF by the momentary tape slack and the TC-756-2 may be placed in stop mode.
8. PB LEVEL controls adjust the playback signal level at the LINE OUTPUTS and the HEADPHONE jack. This adjustment reflects on VU meters with a 0 VU reading corresponding to 0.43 volt output. During normal use, set the inner knob (R channel) to the center click position and align the outer knob (L channel) with the inner knob.
9. The TC-756-2 is designed only for vertical use, and therefore no rubber feet are provided for horizontal use.
10. All function buttons except the stop button have self lock mechanisms.

Note: The above description is applied to both TC-756 and TC-756-2.

## 1-8. NOTES ON REPAIR

### 1. Disassembly

To remove the reel panel, unscrew the 14 screws indicated by \* in the photo below. To remove the cabinet, unscrew the 10 screws attached to the cabinet (4 screws on both sides and 6 screws on the back).

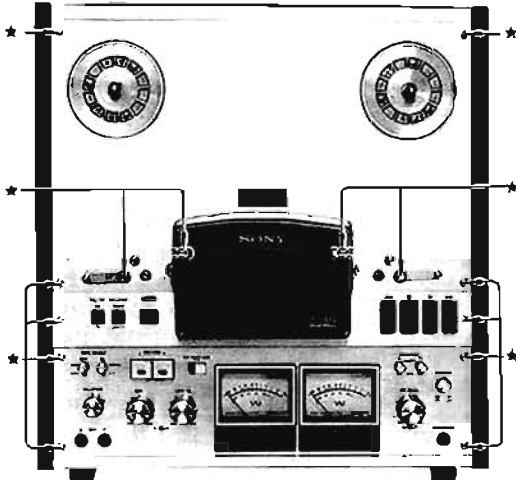

When turning the tape height adjustment screw, the following precaution must be taken: After the screw is turned clockwise as far as it will go, it must not be turned counterclockwise more than  $3\frac{1}{2}$  turns. The tape height may be adjusted with this screw within these limits. If the screw is turned beyond these limits, the washer indicated by \* will be damaged. (See photo.)

The screw indicated by ▲ has been adjusted at the factory and should not be turned. If, however, it happens to be turned, care must be taken that the microswitch (S117) is not touched by the tension arm spacer even if the tape height adjustment screw is turned within the limits mentioned above. Otherwise S117 will be damaged.

tape height adjustment screw

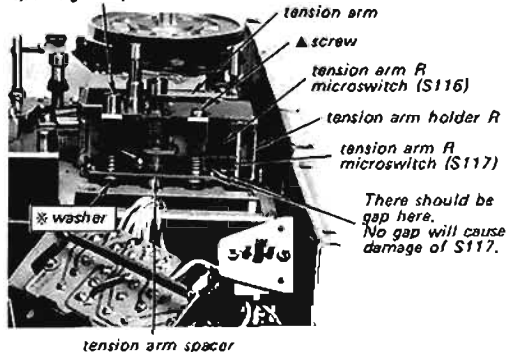

3. Lead wires for the complete circuit board of the bias oscillator should be arranged through the areas and between the parts indicated by ● as shown in the photo.

Also, make sure that the lead wires and other parts do not interfere with the ranges within which the switches operate.

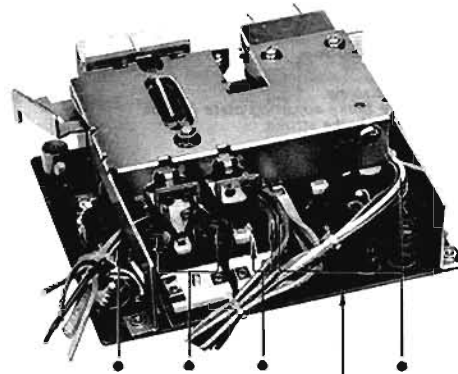

complete circuit board of bias osc.

4. Be sure to insert the function spring projection (indicated by ⊙) into the lever of the EQ (TAPE SELECT) switch as shown in the photo.

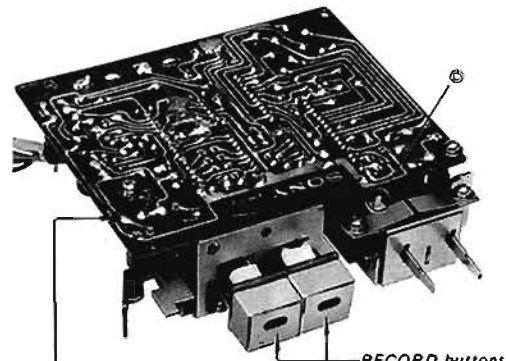

complete circuit board of bias osc.

RECORD buttons

## SECTION 2 ADJUSTMENTS

### 2-1. MECHANICAL ADJUSTMENTS

#### 1. Brake Adjustment (1)

Perform this adjustment for both left and right brakes. After the adjustment, apply locking compound to the adjusted screw.

– Playback mode –

*adjustment screw*  
Adjust the brake adjusting plate for the appropriate brake stroke

– Right side –

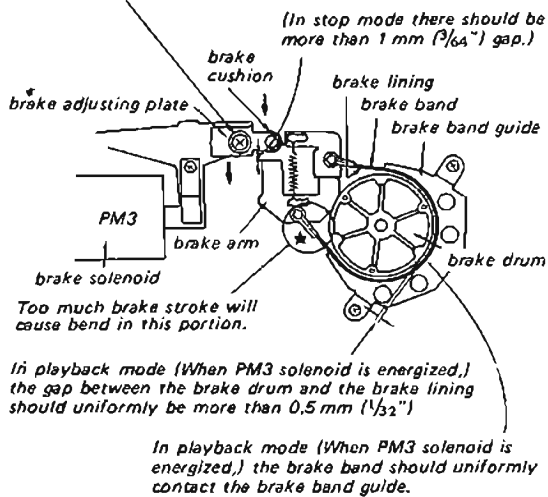

– Left side –

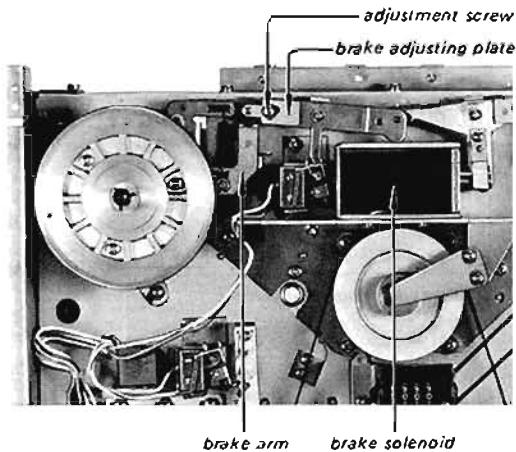

#### 2. Brake Adjustment (2)

Perform this adjustment for both left and right brakes. After the adjustment, apply locking compound to the adjusted screw.

Specification:

Take-up Reel	Supply Reel	Brake Torque
clockwise	counterclockwise	800~2,500 g·cm (11.1~34.8 oz·inch)
counterclockwise	clockwise	600~700 g·cm (8.3~9.7 oz·inch)

– Stop mode –

– Right side –

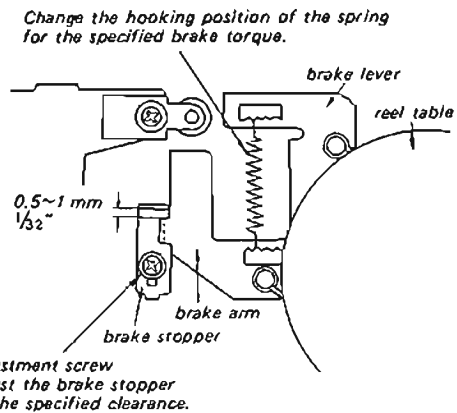

– Left side –

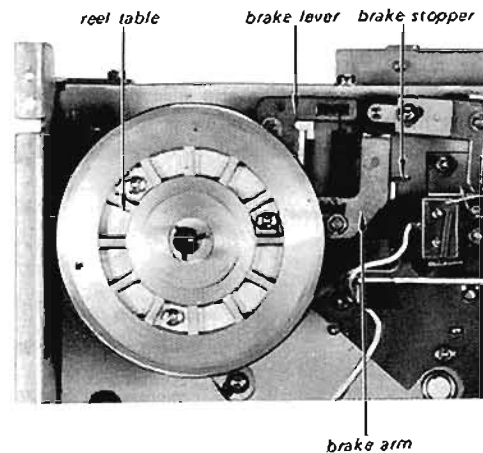



### 3. Adjustor Adjustment

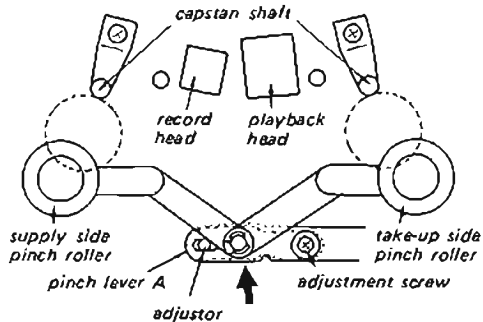

In playback mode and with PAUSE switch to ON, slowly push the pinch lever A in the direction shown by the arrow. When the supply side pinch roller contacts the capstan shaft and starts to rotate, the gap between the take-up side pinch roller and the capstan shaft should be less than 0.5 mm ( $1/64$ "), so that the take-up side pinch roller starts rotating slightly after or almost simultaneously with the start of the supply side pinch roller, if necessary, adjust the adjustor.

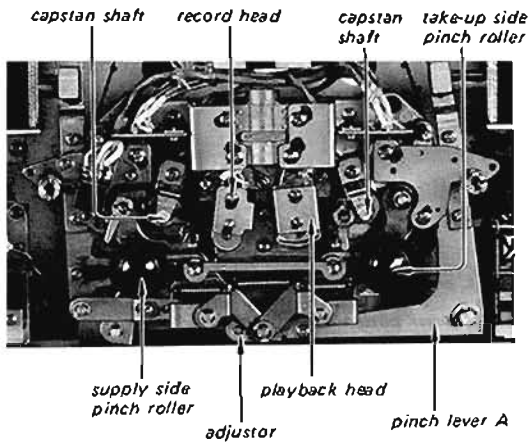

### 4. Pinch Roller Solenoid (R) (PM2) Position Adjustment

After the adjustment, apply locking compound to the adjusted screws.

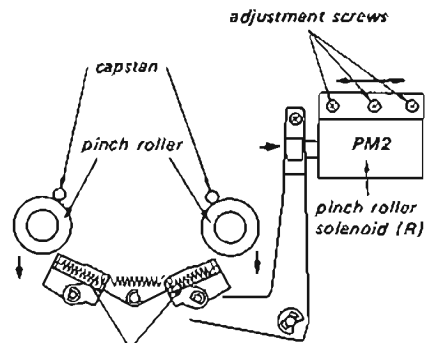

*These two springs should expand 0.5 mm ( $1/64$ " ) longer after the pinch rollers contact the capstans in playback mode. If necessary, adjust the PM2 solenoid position.*

Specification for your reference:

Pinch roller pressure: 1000 g ~ 1600 g (2 lb 3 oz ~ 3 lb 8 oz)

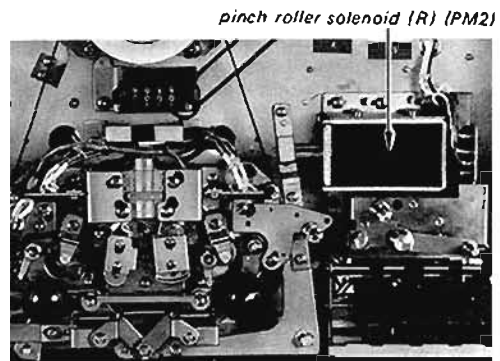

### 5. Pinch Roller Solenoid (L) (PM1) Position Adjustment

After the adjustment, apply locking compound to the adjusted screws.

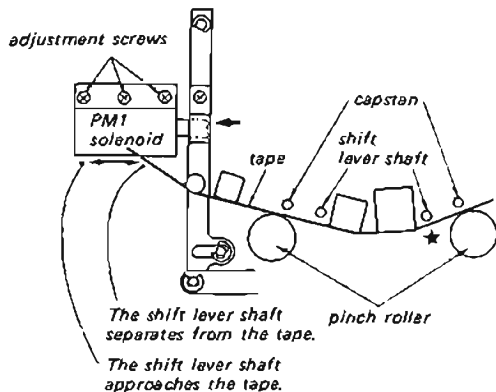

With a tape threaded along the tape path and in playback mode (PM1 solenoid should be energized), turn PAUSE switch ON. At this time the shift lever shafts should not contact the tape and the pinch rollers should separate from the capstans. If necessary, adjust the PM1 solenoid position.

**Note:** The shift lever shaft indicated by \* in the above figure may slightly contact the tape but the other one should not.

Pinch Roller Solenoid (L) (PM1)

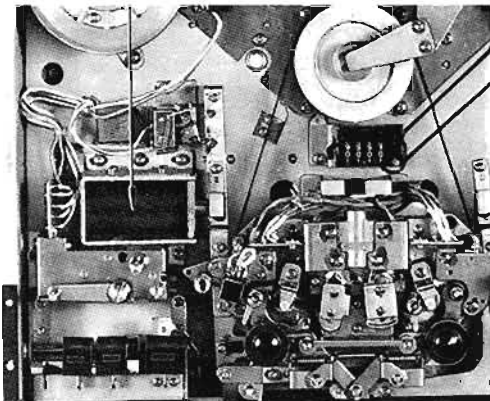

### 6. RECORD Button Lock Adjustment

After the adjustment, apply locking compound to the adjusted screw.

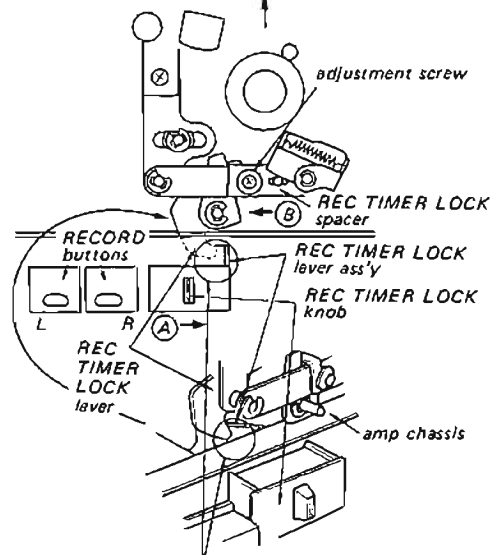
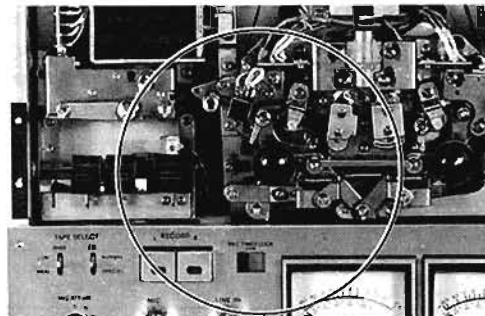

Push L and R RECORD buttons, move REC TIMER LOCK knob in the direction shown by arrow A and then push the 'forward' button. At this time REC TIMER LOCK lever should slightly contact REC TIMER LOCK lever ass'y as shown. If necessary, adjust the REC TIME LOCK spacer.

**Note:**

After the adjustment, and with the L and R RECORD buttons pushed and the REC TIMER LOCK knob pushed in the direction shown by arrow A, and also the forward button pushed, make sure of the following functions.

1. RECORD buttons cannot be released by releasing REC TIMER LOCK knob.
2. REC TIMER LOCK knob cannot be released by moving the REC TIMER LOCK knob further in the direction shown by the arrow A.
3. Push L and R RECORD buttons and then push forward button. At this time the RECORD buttons should not be released.
4. In stop mode L and R RECORD buttons should be released.
5. When L and R RECORD buttons are released, REC TIMER LOCK knob cannot be moved in the direction shown by the arrow A.

### 7. Actuator Adjustment (1)

Perform this adjustment after the Pinch Roller Solenoid (L) (PM1) Position Adjustment. After the adjustment, apply locking compound to the adjusted screw.

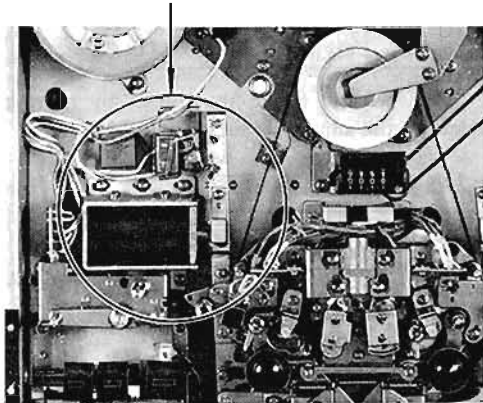
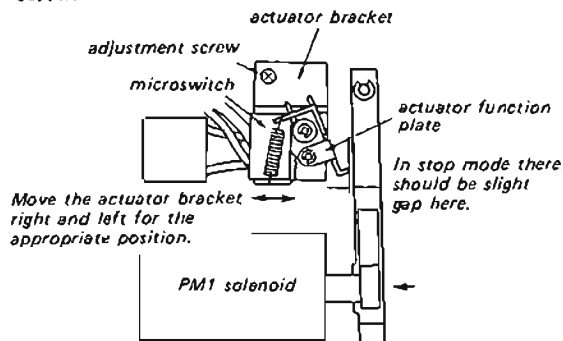

**Note:** The microswitch should turn OFF (click) in 0.5 to 2 seconds after forward button is pushed.

### 8. Actuator Adjustment (2)

Perform this adjustment after the Brake Adjustments (1) and (2). After the adjustment, apply locking compound to the adjusted screw.

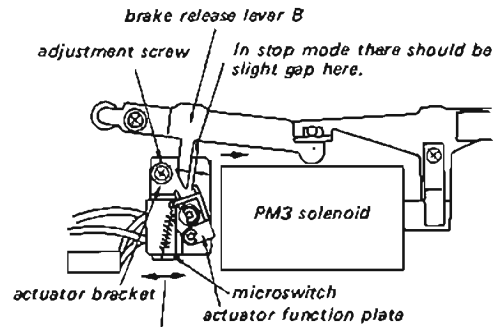

Move the actuator bracket right and left for the appropriate position.

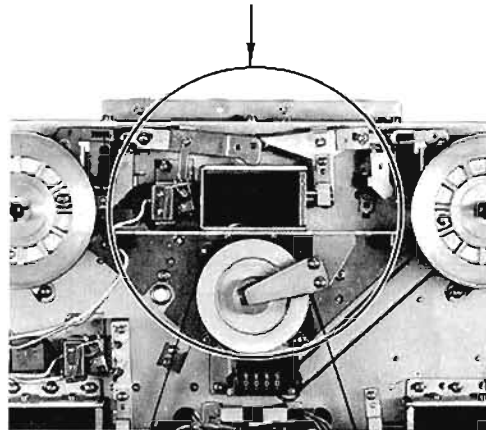

**Note:** The microswitch should turn OFF (click) in 0.5 to 2 seconds after forward button is pushed.

### 9. Fast Forward and Rewind Back-Tension Adjustment

1. Supply the rated power voltage.
2. Fasten the tension arms with rubber bands as shown, thus activating them.
3. Pull the spring scale at a speed of between 9.5 cm/s to 19 cm/s in the direction shown by the arrow for rewind or fast forward mode with REEL SIZE switch at "7" and "10". Measure the back tension torque for rewind and fast forward modes. Torques should be as shown in the following table.

#### Specification:

Mode	REEL SIZE Switch	Back-Tension Torque
rewind	10	110 to 140 g·cm (1.53 to 1.95 oz·inch)
	7	80 to 100 g·cm (1.11 to 1.39 oz·inch)
fast forward	10	110 to 140 g·cm (1.53 to 1.95 oz·inch)
	7	80 to 100 g·cm (1.11 to 1.39 oz·inch)

If necessary, adjust the torque by moving the sliders of the adjustable resistor (R901).

— Right side —

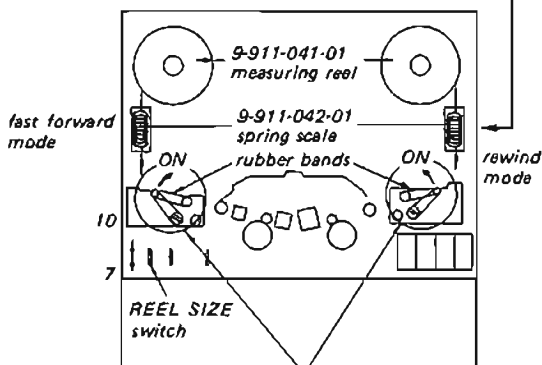
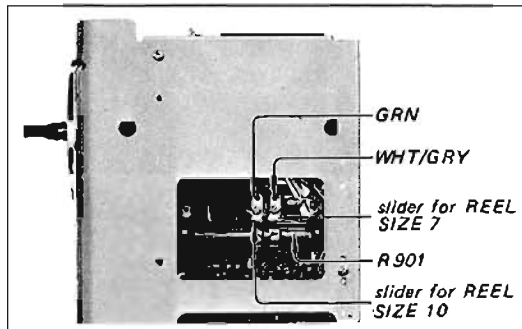

Fasten the tension arms with rubber bands to operate the unit.

### 10. Playback Take-up Torque Adjustment

1. Supply the rated power voltage.
2. Fasten the tension arms with rubber bands as shown, thus activating them.
3. Turn the TAPE SPEED switch to "19 cm 7½."
4. Place the unit in playback mode.
5. Pull the spring scale in the direction shown by the arrow and measure the take-up torque with REEL SIZE switch at "10" and "7". Torques should be as shown in the following table.

#### Specification:

REEL SIZE switch	Take-up Torque
10	580 to 620 g·cm (80.5 to 86.1 oz·inch)
7	280 to 320 g·cm (38.9 to 44.5 oz·inch)

If necessary, adjust the torque by moving the sliders of the adjustable resistor (R902).

— Left side —

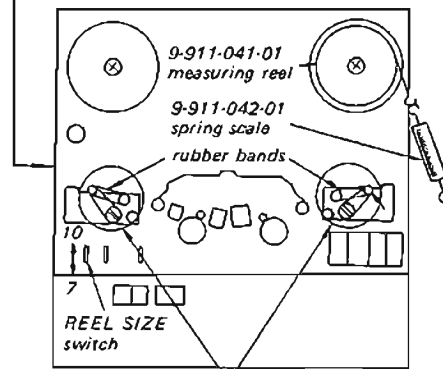
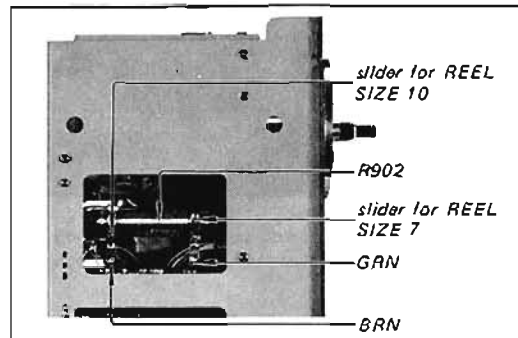

Fasten the tension arms with rubber bands to operate the unit.

### 11. Reel Table Height Adjustment

After the adjustment, apply locking compound to the adjusted screws.

1. Thread the tape from a 180 mm (7 inches) plastic reel as shown.
2. Fasten the tension arms with rubber bands as shown.
3. Adjust the reel table height so that the tape travels in the center of both reel flanges in fast forward and rewind modes.

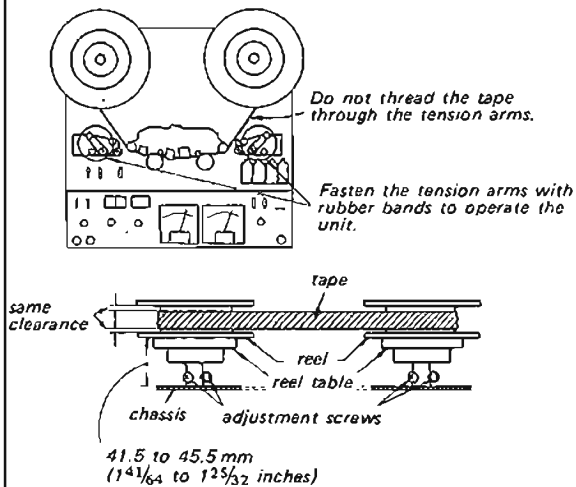

### 12. Tape Guides Adjustment (1)

1. Thread the tape from a 180 mm (7 inches) plastic reel as shown.
2. Turn the two screws indicated by ★ counterclockwise until it stops, and then turn them clockwise in 1 1/4 turns.
3. Turn the two screws indicated by ● so that the tape travels in the center of both reel flanges in rewind and fast forward modes.
4. Turn the two tape guides indicated by ▲, for fine adjustment, so that the tape travels in the center of the guides without tape curl in playback mode.
5. When the tape curls, repeat the above steps.

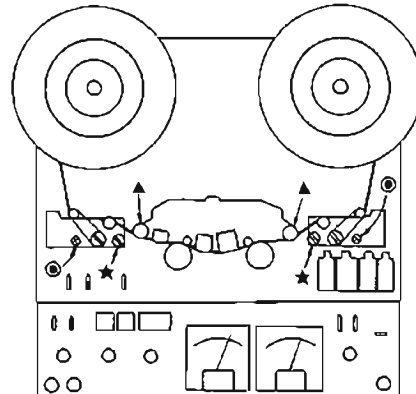

### 13. Tape Guide Adjustment (2)

Perform this adjustment after the reel table height adjustment and the tape guides adjustment (1) are completed. Tape should not curl at each tape guide B and D.

If necessary, adjust the tape guides B and D with the tape guide D as standard.

- Note:**
1. Make sure that the three heads are correctly positioned as specified. If necessary, perform the head height adjustments on page 19 and 21.
  2. If all the tape guides B and D are not correctly positioned, adjust them so that the tape travels in the center of the pinch roller.

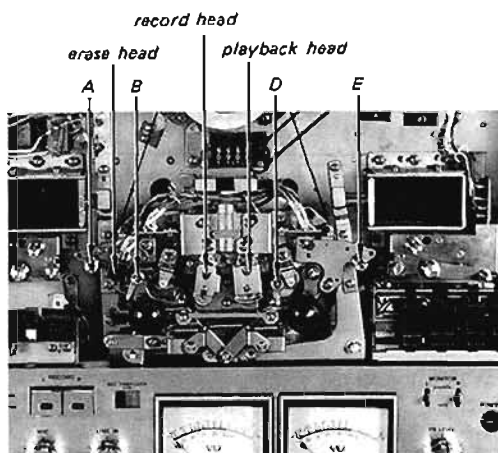
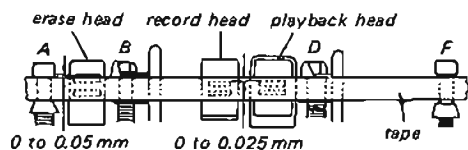

### 14. Tape Shifter Position Check

Perform this check for both left and right shifters with the unit in horizontal position.

1. In playback mode the shift levers should not touch the head deck.



2. At tape end in rewind and fast forward modes, there should be more than 2 mm ( $\frac{3}{32}$  inch) gap between the tape and the record and playback heads. At this time the tape may touch the erase head.

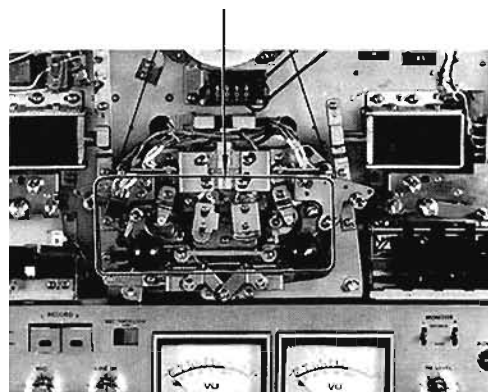
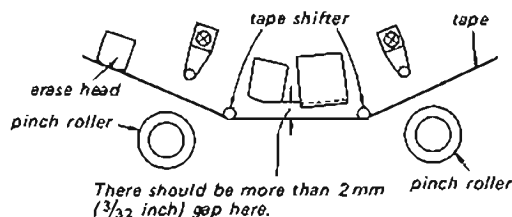

### 15. Function Switch Operation Check

1. Push the POWER switch ON with the tension arms released. Next push each function button. No operation should take place, and each function button should not lock.
2. When the tension arm L and/or R are activated, the stop solenoid should be de-energized. The solenoid can be seen when looked at in the direction of the arrow indicated by \*. When the solenoid is de-energized, a click can be heard.
3. Activate the tension arm L or R, and make sure of the following functions.
  - 3-1. Push the forward button. The button should lock. When the activated tension arm is released, the locked button should release itself.
  - 3-2. Push the forward button. Then push the stop button. At this time, the locked forward button should release itself.
  - 3-3. Push the forward button. Then push the POWER switch OFF. The locked forward button should remain locked. Next push the POWER switch ON. The forward button should still remain locked.
  - 3-4. Push the fast forward button. The button should lock. When the activated tension arm is released, the locked button should release itself.
  - 3-5. Push the fast forward button. Then push the stop button. At this time the locked button should release itself.
  - 3-6. Push the rewind button. The button should lock. When the activated tension arm is released, the locked button should release itself.
  - 3-7. Push the rewind button. Then push the stop button. At this time the locked button should release itself.

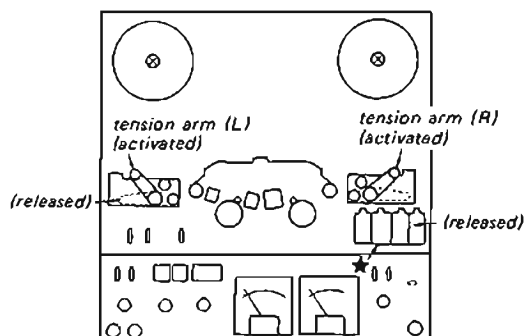

### 16. Tension Regulator Adjustment (Not normally performed)

**Note:** For this adjustment a super low frequency oscillator (3 Hz to 10 Hz) is required. Without the oscillator, do not perform this adjustment and only replace the defective parts. When adjusting adjustable resistors, turn them in the direction of increasing torque, so that the torque rises to the specified value.

1. Supply the rated power voltage.
2. Unsolder the three lead wires of the FG (frequency generator) coil in the supply reel motor M1, connect a super low frequency oscillator of 1 Vp-p output across R70) through a 100 $\mu$ F electrolytic capacitor.
3. Set TAPE SPEED switch to "9.5 cm 3 $\frac{3}{4}$ " and REEL SIZE switch to "10".
4. Adjust the oscillator frequency so that the voltage between the emitter of Q712 transistor and the chassis ground is 9 volts in playback mode.
5. With the frequency adjusted in step 4, adjust R731 so that the supply motor torque is 250 g-cm (3.47 oz-inch).
6. Change the oscillator frequency to 10 Hz and adjust R717 so that the torque is 80 g-cm (1.11 oz-inch).
7. Change the oscillator frequency to 3.3 Hz and adjust R736 so that the torque is 310 g-cm (4.30 oz-inch).
8. Repeat steps 6 and 7 once more.
9. Set TAPE SPEED switch to "38 cm 15" and change the oscillator frequency to 6.6 Hz. Then adjust R737 so that the torque is 310 g-cm (4.30 oz-inch).

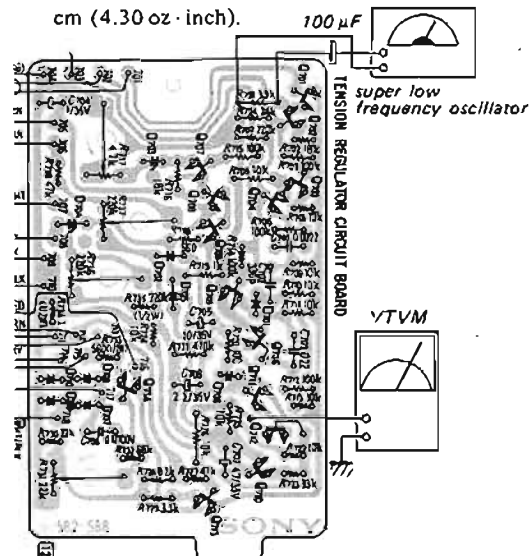

## 2-2. ELECTRICAL ADJUSTMENTS

### Precaution:

- Clean the following parts with a swab moistened with alcohol:
 

record head	pinch roller
playback head	rubber belts
erase head	idlers
capstan	tape guides
- Demagnetize record, playback and erase heads with a head demagnetizer.
- Do not use magnetized screwdriver for adjustments.
- After adjustments, apply locking compounds to the adjusted parts.
- Adjustments should be performed in the order listed in this service manual.
- Adjustments and measurements should be performed for each L and R channel with the rated power supply voltage unless otherwise specified.
- Switches and controls, which are not given in "Settings" for the each adjustment, can be set in any modes or positions. Power switch, however, should be ON unless otherwise noted.

### Test Equipment/Tools Required:

audio oscillator (af osc)  
 VTVM  
 VOM  
 attenuator (600Ω)  
 digital frequency counter or speed checker (SONY LFM-30)  
 oscilloscope  
 resistors: 600 Ω, 10 kΩ, 100 kΩ  
 SONY test tape  
 J-19-F2

Tone:	1	2	3	4	5	6	7
Frequency: (Hz)	400	400	10 k	12.5 k	7 k	80	40
Level (dB):	0	-10	-10	-10	-10	-10	-10

J-19-A2 (12.5 kHz, -10 dB)  
 SPC-47 (4 kHz, 0 dB)  
 blank tapes (completely erased)  
 NPS-1 (for NORMAL record)  
 SLH-S1 (for SPECIAL record)

### Normal Input Level

	Impedance	Level
MIC	300 Ω	-60 dB (0.77 mV)
LINE IN	10 kΩ	-10 dB (0.25 V)

### Normal Output Level

	Load Impedance	Level
LINE OUT	100 kΩ	-5 dB (0.44 V)
HEADPHONE	8 Ω	-28 dB (31 mV)

### 1. B + 27 V Adjustment

#### Settings:

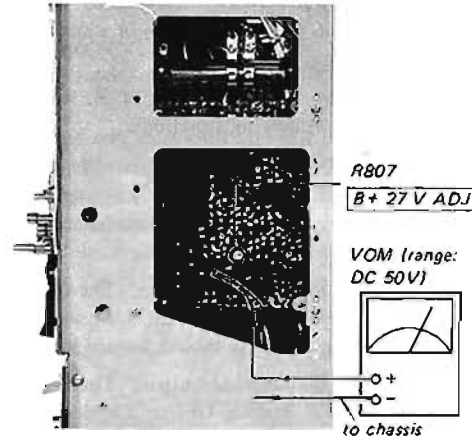

#### Procedure:

Adjust R807 for 26.5 to 27.0 V DC on VOM.

Note: The ripple voltage should be less than 1 mV p-p.



## 2. Tape Speed Adjustment

### Settings:

REEL SIZE switch: 7  
 TAPE SPEED switch: 19 cm, 7½ and 38 cm, 15  
 EQ (TAPE SELECT) switch: NORMAL  
 MONITOR switch: TAPE  
 PB LEVEL control: mechanical mid

### Procedure:

Mode: playback

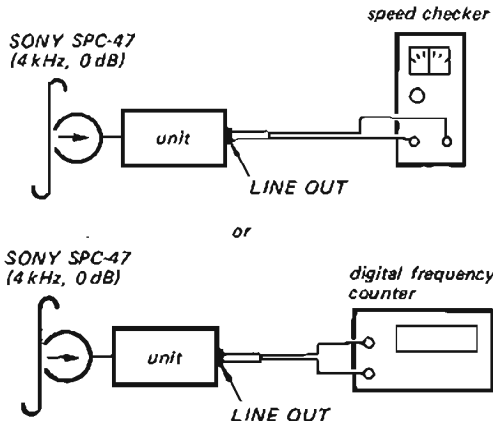

TAPE SPEED	Adjust	Specification	
		speed checker	digital frequency counter
19 cm, 7½	R618	-1 ~ +1%	3,960 ~ 4,040 Hz
38 cm, 15	R616	-1 ~ +1%	7,920 ~ 8,080 Hz

### Adjustment Location:

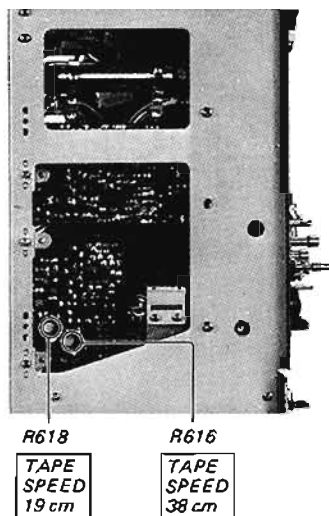

## 3. Meter Level Adjustment

### Settings:

EQ (TAPE SELECT) switch: NORMAL  
 MONITOR switch: SOURCE  
 PB LEVEL control: mechanical mid

### Procedure:

1. Calibrate the level meters for 0% indication with POWER switch OFF.
2. Adjust LINE IN control for -5 dB (0.44 V).

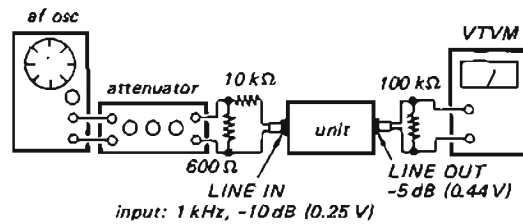

3.

Adjust	Remarks
R336 (L channel)	0 VU on the level meters
R436 (R channel)	

### Adjustment Location:

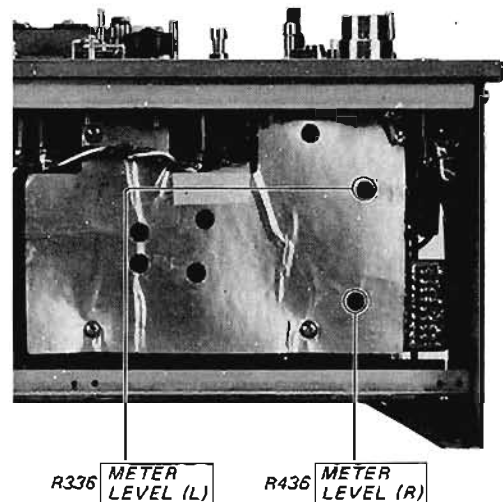

#### 4. Playback Head Angle Adjustment

##### Settings:

REEL SIZE switch: 7  
TAPE SPEED switch: 19 cm, 7½  
EQ (TAPE SELECT)  
switch: NORMAL  
MONITOR switch: TAPE  
PB LEVEL control: mechanical mid

##### Procedure:

Mode: playback

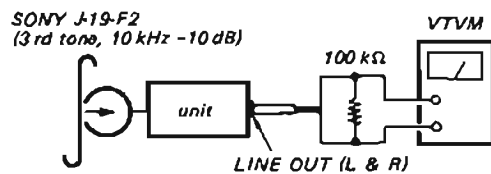

Loosen the adjustment screws and correctly position the playback head for the highest VTVM reading.

**Note:** Slightly touch the supply reel and at this time the VTVM reading deviation should be less than 1 dB.

##### Adjustment Location:

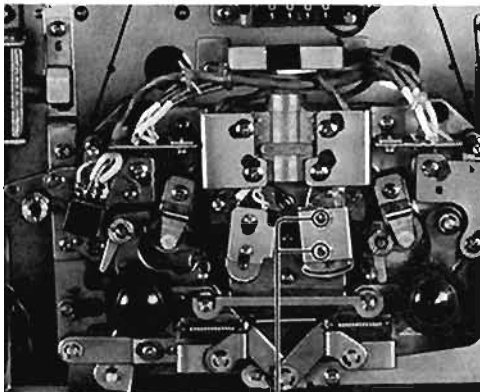

playback head angle adjustment screws.

#### 5. Playback Head Height Adjustment

##### Settings:

REEL SIZE switch: 7  
TAPE SPEED switch: 19 cm, 7½

##### Procedure:

Play back a tape and align the tape edge and the playback head core as shown by turning the height and zenith adjustment screws.

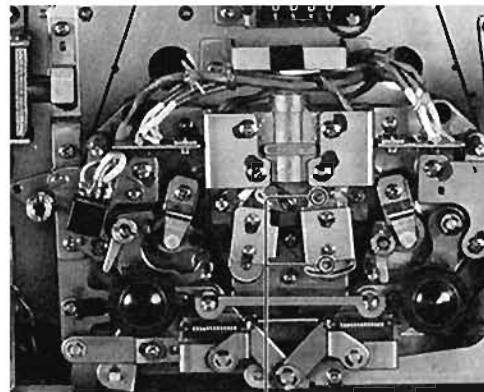
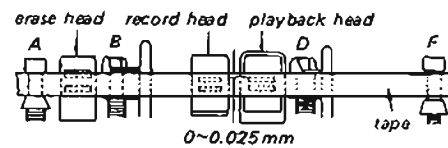

playback head height and zenith adjustment screws.

## 6. Playback Head Azimuth and Phase Adjustments

### Settings:

REEL SIZE switch: 7  
 TAPE SPEED switch: 19 cm, 7½  
 EQ (TAPE SELECT) switch: NORMAL  
 MONITOR switch: TAPE  
 PB LEVEL control: mechanical mid

### Procedure:

If an oscilloscope is available, employ Procedure 2.  
 If a simplified test is to be made, follow Procedure 1.

#### 1. Mode: playback

SONY J-19-A2  
 (12.5 kHz, -10 dB)

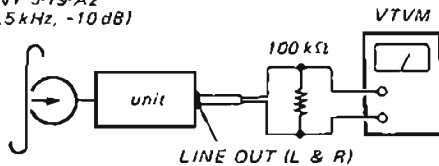

Turn the adjustment screw shown in the photo below for the highest VTVM reading. If the highest peaks for L and R do not coincide, place the adjustment screw to the mechanical mid of the two positions for the peaks.

#### 2. Mode: playback

SONY J-19-A2  
 (12.5 kHz, -10 dB)

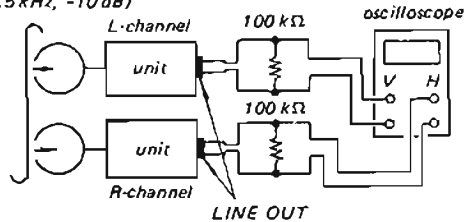

Adjust	On the oscilloscope			
azimuth adjust screw				
	in phase	30°	40°	more than 90°
		good		wrong

### Adjustment Location:

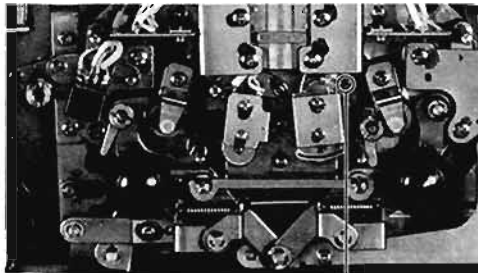

playback head azimuth adjustment screw.

## 7. Playback Equalizer Adjustment

### Settings:

REEL SIZE switch: 7  
 TAPE SPEED switch: 19 cm, 7½  
 EQ (TAPE SELECT) switch: NORMAL  
 MONITOR switch: TAPE  
 PB LEVEL control: mechanical mid

### Procedure:

Mode: playback

SONY J-19-F2  
 (2nd tone, 400 Hz -10 dB)  
 (3rd tone, 10 kHz -10 dB)

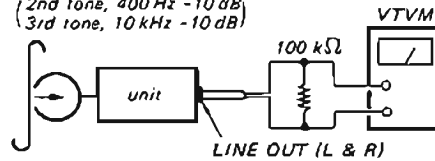

	Adjust	VTVM reading
2nd tone 400 Hz	PB LEVEL control	0 dB (0.775 V)
3rd tone 10 kHz	R311 (L channel) R411 (R channel)	-0.5 dB (0.73V)

Specification for your reference in case of a more detailed test:

J-19-F2 (TAPE SPEED: 19 cm, 7½)	
400 Hz	0 dB (standard)
10 kHz	-0.5 ± 1 dB
12.5 kHz	-0.5 ± 1.5 dB
7 kHz	-0.5 ± 1.5 dB
80 Hz	+2 ± 2 dB
40 Hz	+1.5 ± 2 dB

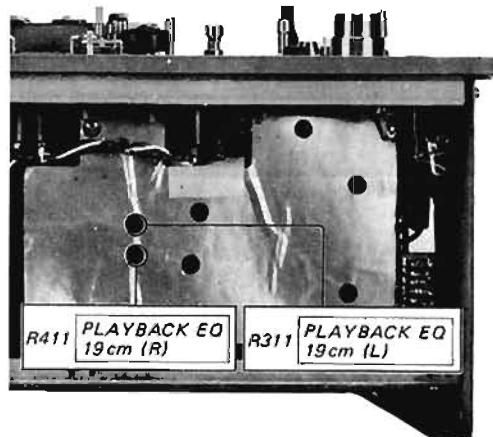

## 8. Playback Level Adjustment

### Settings:

REEL SIZE switch: 7  
 TAPE SPEED switch: 19 cm, 7½  
 EQ (TAPE SELECT) switch: NORMAL  
 MONITOR switch: TAPE  
 PB LEVEL control: mechanical mid

### Procedure:

Mode: playback

SONY J-19-F2  
 (1st tone, 400 Hz 0 dB)

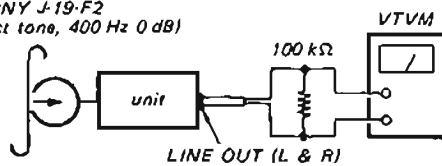

Adjust	VTVM reading
R317 (L channel)	-5 dB (0.775 V)
R417 (R channel)	allowance: ±1 dB

- Note: 1. Turn the EQ (TAPE SELECT) switch to SPECIAL position and make sure that the output level lowers by 2.4 ± 1 dB.  
 2. Difference between L and R channels should be within 1 dB.

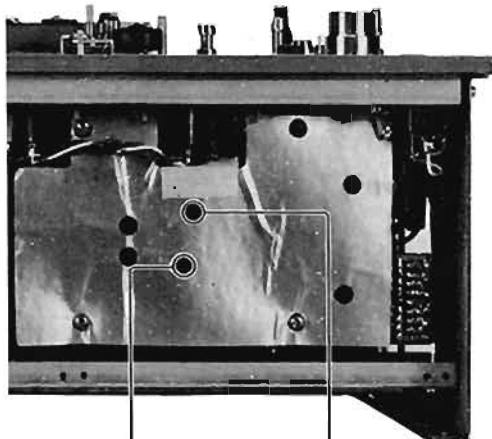

R417 PLAYBACK LEVEL (R)      R317 PLAYBACK LEVEL (L)

## 9. Record Head Angle Adjustment

### Settings:

REEL SIZE switch: 7  
 TAPE SPEED switch: 19 cm, 7½  
 BIAS (TAPE SELECT) switch: LOW  
 EQ (TAPE SELECT) switch: NORMAL  
 MONITOR switch: TAPE  
 LINE IN control: mechanical mid  
 PB LEVEL control: mechanical mid

### Procedure:

Mode: record and simultaneous playback

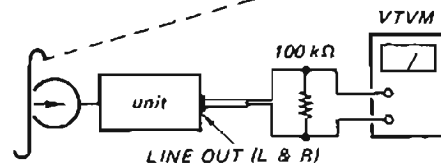
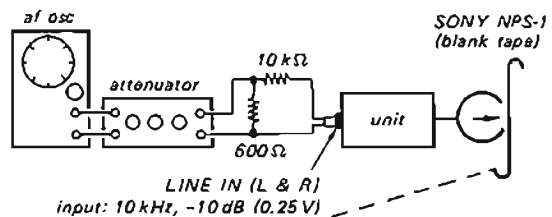

Loosen the adjustment screws and correctly position the record head for the highest VTVM reading.

Note: Slightly touch the supply reel and at this time the VTVM reading deviation should be less than 1 dB.

### Adjustment Location:

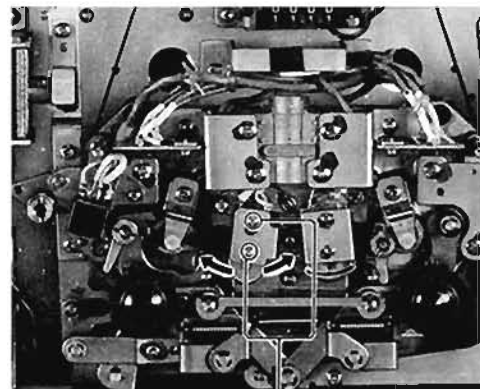

record head angle adjustment screws

## 10. Record Head Height Adjustment

### Settings:

REEL SIZE switch: 7  
 TAPE SPEED switch: 19 cm, 7½  
 BIAS (TAPE SELECT) switch: LOW  
 EQ (TAPE SELECT) switch: NORMAL  
 MONITOR switch: TAPE  
 LINE IN control: mechanical mid  
 PB LEVEL control: mechanical mid

### Procedure:

Mode: record and simultaneous playback

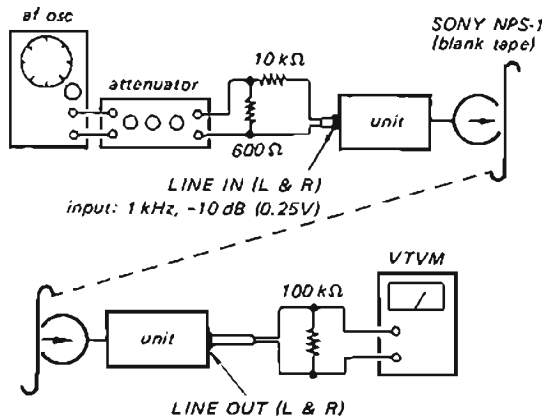

Turn the height and zenith adjustment screws for the highest VTVM reading.

### Adjustment Location:

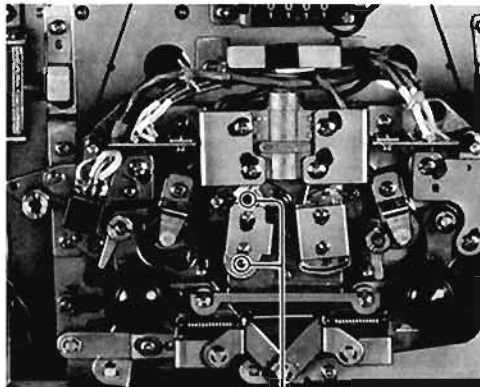

record head height and zenith adjustment screws

## 11. Record Head Azimuth and Phase Adjustments

### Settings:

REEL SIZE switch: 7  
 TAPE SPEED switch: 19 cm, 7½  
 BIAS switch: LOW  
 TAPE SELECT (EQ) switch: NORMAL  
 MONITOR switch: TAPE  
 LINE IN control: mechanical mid  
 PB LEVEL control: mechanical mid

### Procedure:

When an oscilloscope is available, employ Procedure 2.  
 2. When a simplified test is made, follow Procedure 1.

#### 1. Mode: record and simultaneous playback

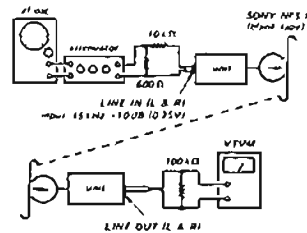

Turn the adjustment screw for the highest VTVM reading. If the highest peaks for L and R do not coincide, place the adjustment screw to the mechanical mid of the two positions for the peaks.

#### 2. Mode: record and simultaneous playback

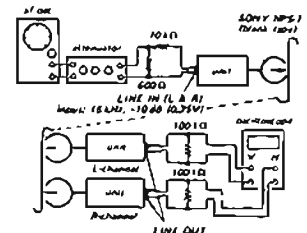

Adjust	On the oscilloscope			
azimuth				
adjust				
result	180-phase	30°	90°	180° (also 90°)
	good		wrong	

Note: Difference between the highest levels of L and R and the finally adjusted level should be within 1 dB.

### Adjustment Location:

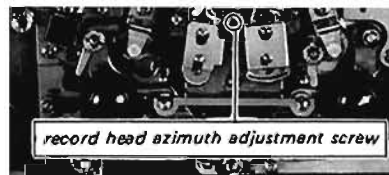

record head azimuth adjustment screw

### 12. Bias Trap Adjustment

Settings:

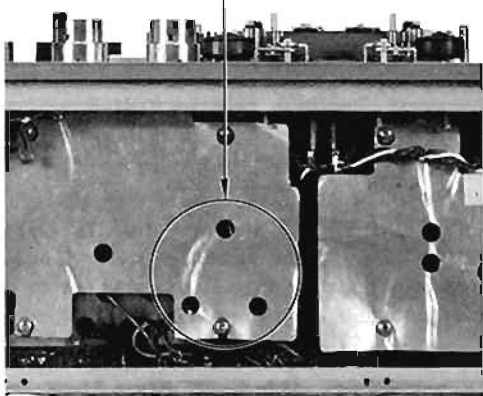
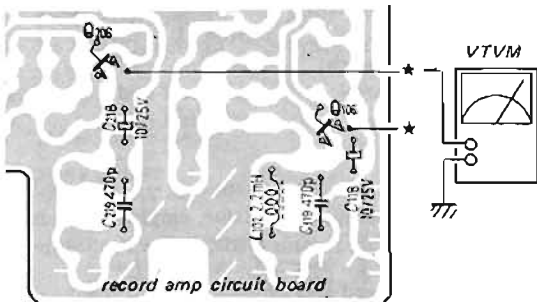
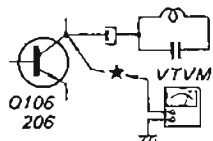

Procedure:

In record mode turn L102 (L-channel) and L202 (R-channel) for the lowest VTVM reading ( $\sim 40$  dB (7.7 mV) or less).

Adjustment Location:

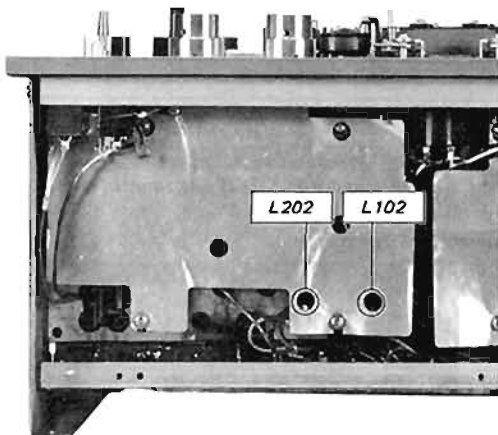

### 13. Record Bias Adjustment

Settings:

- REEL SIZE switch: 7
- TAPE SPEED switch: 19 cm 7 1/2
- BIAS (TAPE SELECT) switch: LOW
- EQ (TAPE SELECT) switch: SPECIAL
- MONITOR switch: TAPE
- LINE IN control: mechanical mid
- PB LEVEL control: mechanical mid

Procedure:

Mode: record and simultaneous playback

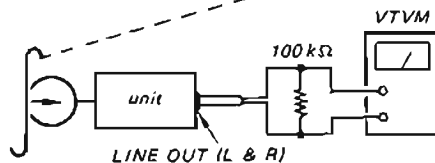
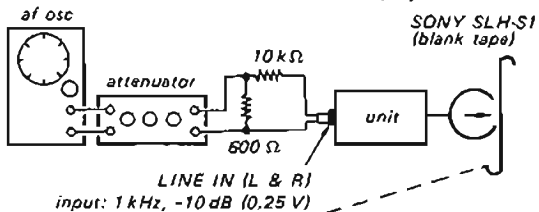

As trimmer capacitor C511 (L-channel) or C518 (R-channel) is slowly turned clockwise, VTVM reading will go up to a maximum and then start falling again. Adjust the capacitor until VTVM reads 0.5 dB below and beyond the maximum reading.

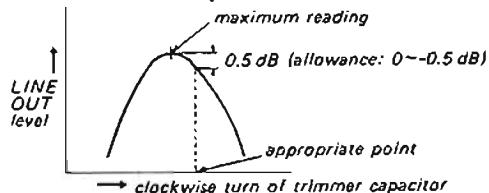

Adjustment Location:

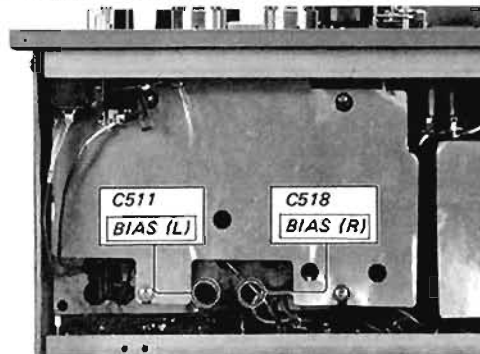

**14. Overall Frequency Response (SPECIAL RECORD EQ) Adjustment**

**Settings:**

- REEL SIZE switch: 7
- TAPE SPEED switch: 38 cm 15, 19 cm 7½
- BIAS (TAPE SELECT) switch: LOW
- EQ (TAPE SELECT) switch: SPECIAL
- MONITOR switch: TAPE
- LINE IN control: mechanical mid
- PB LEVEL control: mechanical mid

**Procedure:**

Mode: record and simultaneous playback

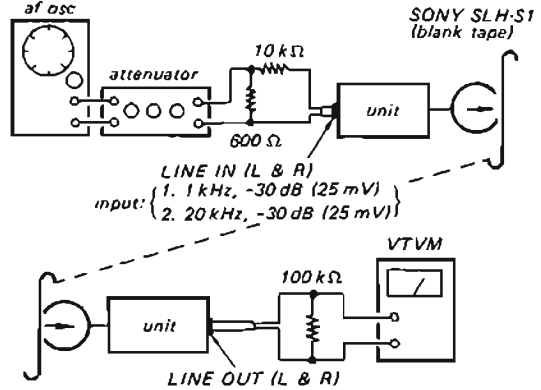

Tape Speed	Input Signal		Adjust		VTVM Reading
	Freq.	Level	L-ch	R-ch	
38 cm/s (15 ips)	1 kHz	-30 dB (25 mV)	—	—	Memorize
	15 kHz		R515	R516	for +0.5 dB relative to the reading at 1 kHz
	30 kHz		L503	L504	for the same reading relative to the reading at 1 kHz
19 cm/s (7½ ips)	1 kHz	-30 dB (25 mV)	—	—	Memorize
	10 kHz		C323 C324	C423 C424	for +0.5 dB relative to the reading at 1 kHz
	25 kHz		—	—	Make sure of the same reading relative to the reading at 1 kHz.

**Adjustment Location:**

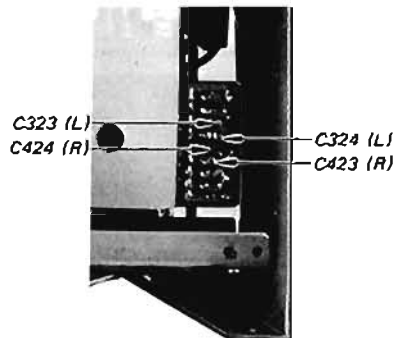
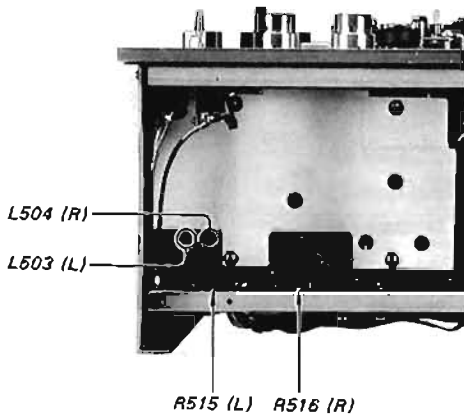

Adjust by soldering or unsoldering the portions indicated.

### 15. Overall Frequency Response (NORMAL RECORD EQ) Adjustment

#### Settings

REEL SIZE switch: 7  
 TAPE SPEED switch: 38 cm 15, 19 cm 7½  
 BIAS (TAPE SELECT) switch: LOW  
 EQ (TAPE SELECT) switch: NORMAL  
 MONITOR switch: TAPE  
 LINE IN control: mechanical mid  
 PB LEVEL control: mechanical mid

#### Procedure:

Mode: record and simultaneous playback

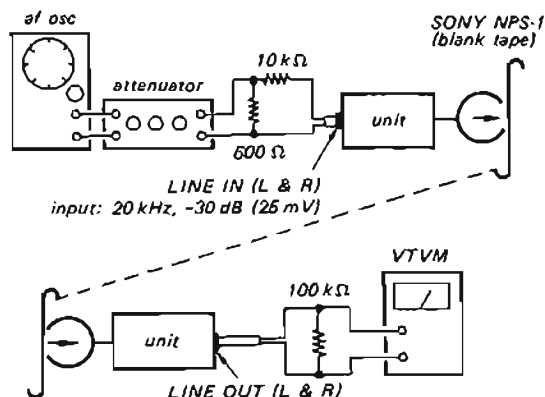

Tape Speed	Input Signal		Adjust		VTVM Reading
	Freq.	Level	L-ch	R-ch	
38 cm/s (15 ips)	1 kHz	-30 dB (25 mV)	—	—	Memorize
	15 kHz		R517	R518	for +0.5 dB relative to the reading at 1 kHz
	20 kHz		L501	L502	for the same reading relative to the reading at 1 kHz
19 cm/s (7½ ips)	1 kHz	-30 dB (25 mV)	—	—	Memorize
	10 kHz		C321 C322	C421 C422	for +0.5 dB relative to the reading at 1 kHz
	15 kHz		—	—	Make sure of the same reading relative to the reading at 1 kHz.

#### Adjustment Location:

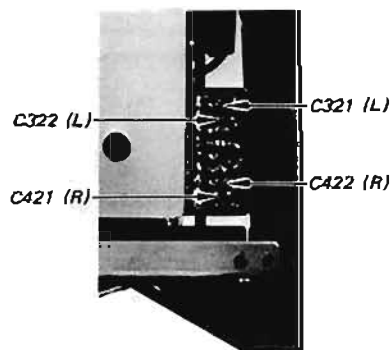
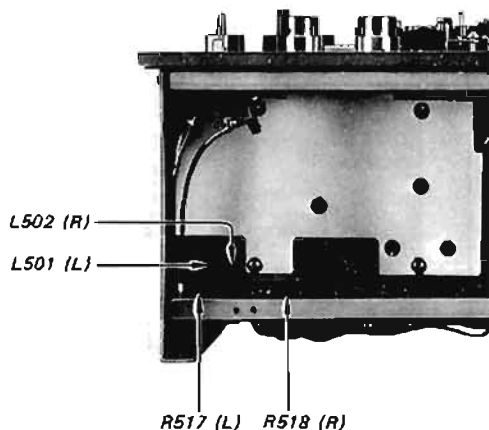

Adjust by soldering or unsoldering the portions indicated.



### 16. Dummy Coil Adjustment

#### Settings:

REEL SIZE switch: 7  
 TAPE SPEED switch: 19 cm, 7½  
 BIAS (TAPE SELECT) switch: LOW  
 EQ (TAPE SELECT) switch: NORMAL  
 MONITOR switch: TAPE  
 LINE IN control: mechanical mid  
 PB LEVEL control: mechanical mid

#### Procedure:

Mode: record and simultaneous playback

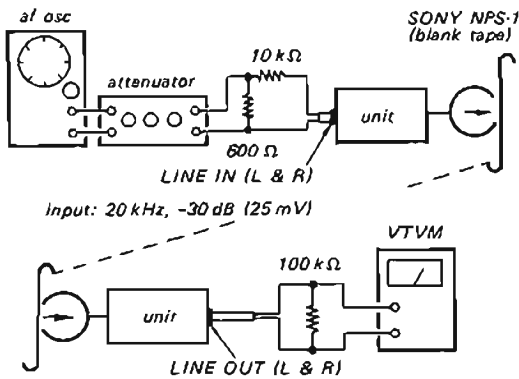

Step	Mode	Adjust	Remarks
1	stereo record and simultaneous playback	—	same VTVM reading
2	L channel record and simultaneous playback	L508	
3	R channel record and simultaneous playback	L507	

#### Adjustment Location:

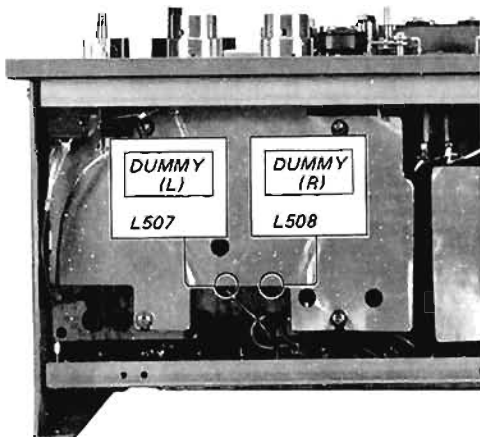

### 17. Record Level Adjustment

#### Settings:

REEL SIZE switch: 7  
 TAPE SPEED switch: 38 cm, 15  
 BIAS (TAPE SELECT) switch: LOW  
 EQ (TAPE SELECT) switch: SPECIAL  
 MONITOR switch: TAPE  
 LINE IN control: mechanical mid  
 PB LEVEL control: mechanical mid

#### Procedure:

Mode: record and simultaneous playback

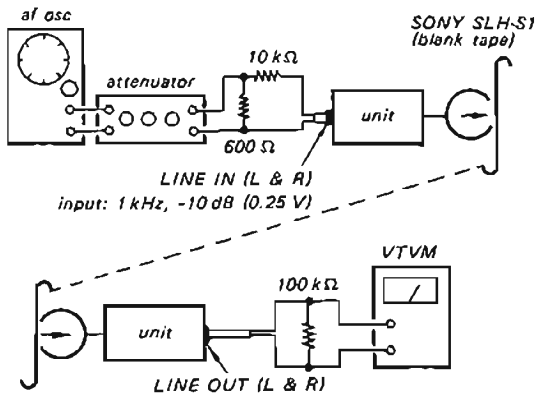

Adjust	VTVM reading
R125 (L channel) R225 (R channel)	0 dB (0.775 V)

#### Adjustment Location:

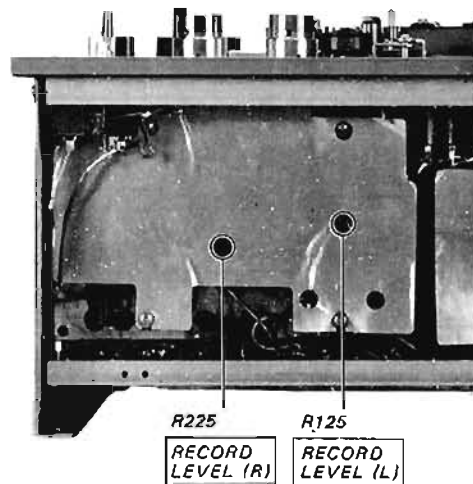

## SECTION 3 DIAGRAMS

3-1 (A). LEVEL DIAGRAMS (TC-756-2) Note: The level diagrams for TC-756: on page 62.

### Playback Mode

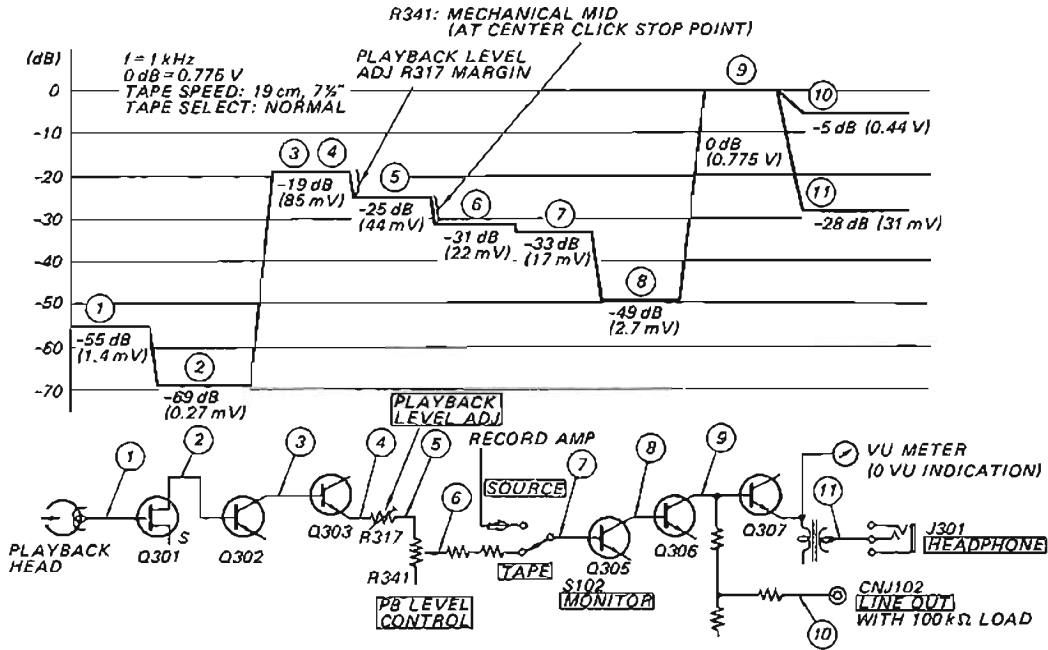

### Record Mode

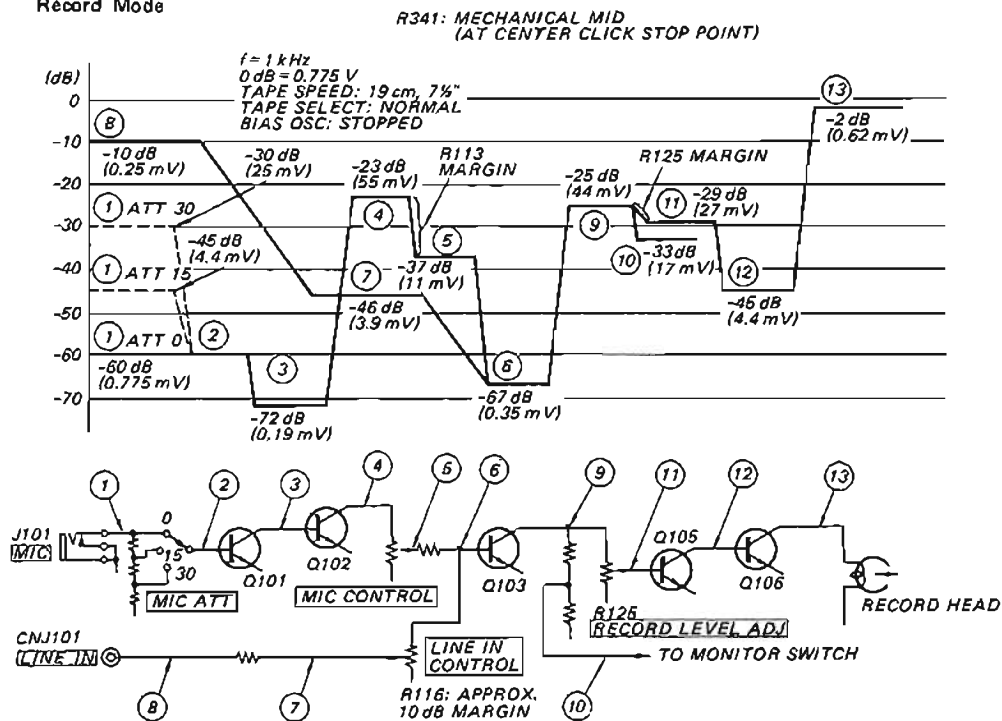

# TC-756/TC-756-2

## 3.2. SCHEMATIC DIAGRAM – AMP SECTION

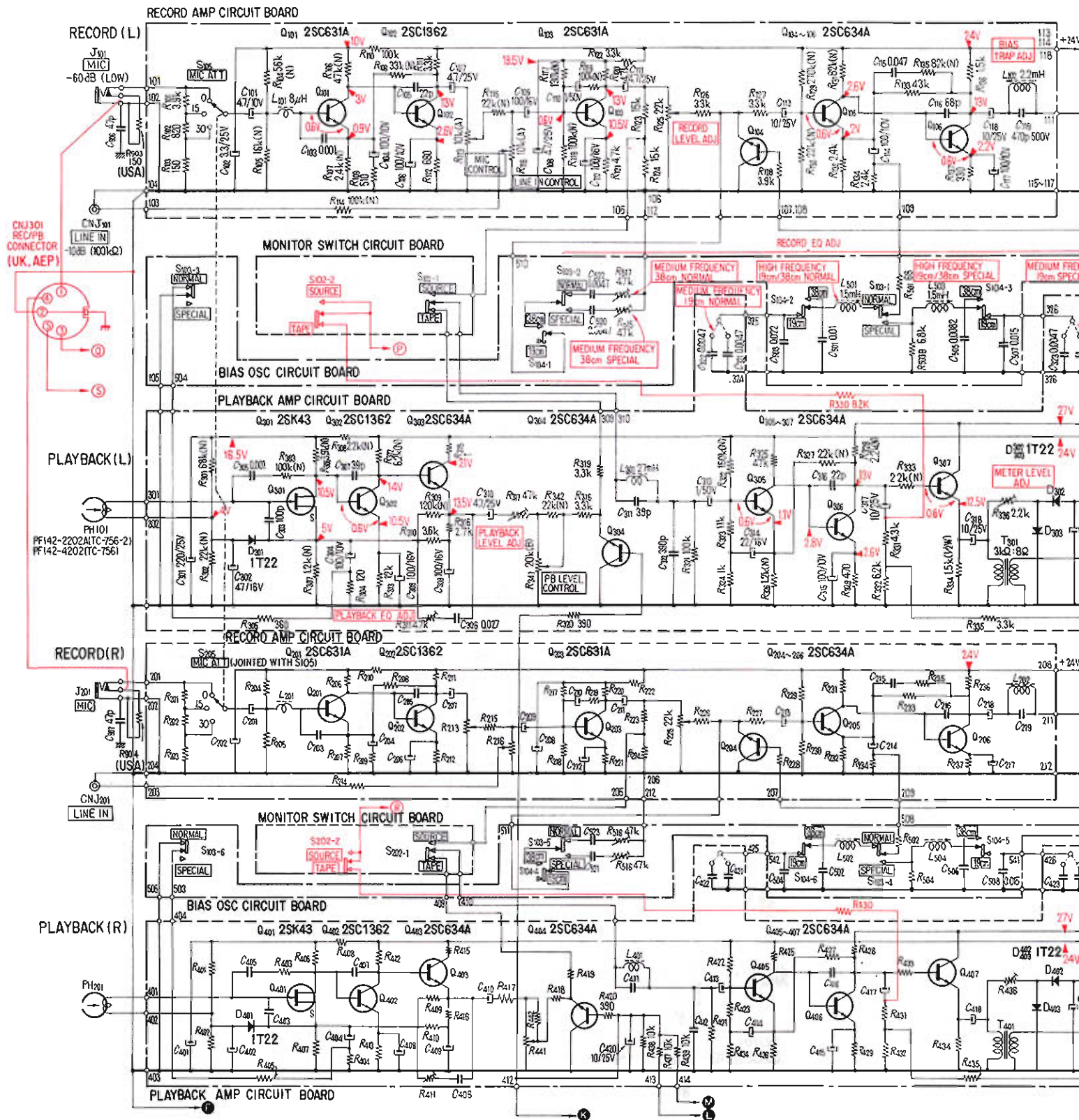

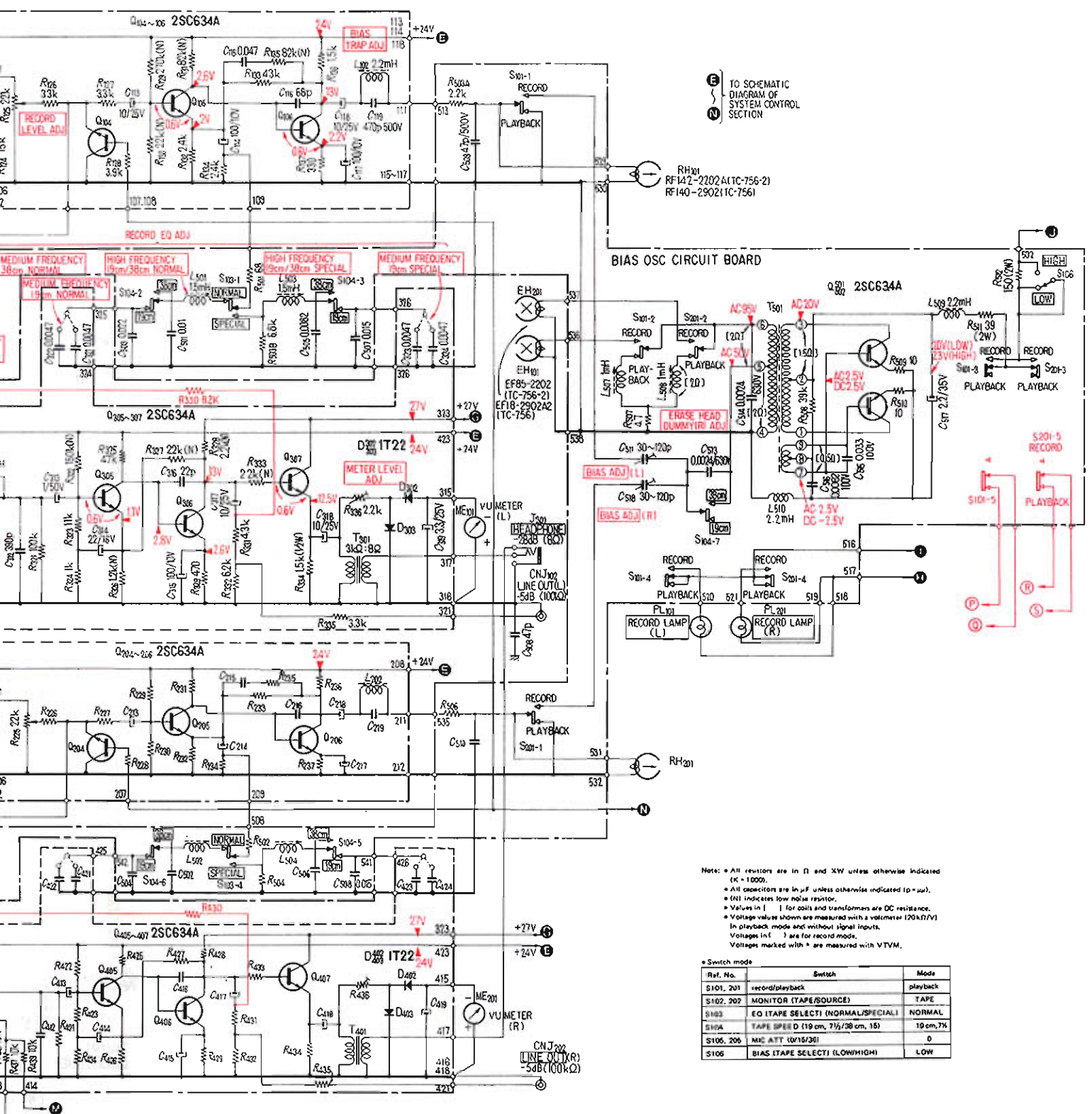

(E) TO SCHEMATIC  
 DIAGRAM OF  
 SYSTEM CONTROL  
 SECTION

BIAS OSC CIRCUIT BOARD

Note: • All resistors are in  $\Omega$  and  $\text{k}\Omega$  unless otherwise indicated  
 (K = 1000).  
 • All capacitors are in  $\mu\text{F}$  unless otherwise indicated ( $\mu = \mu\text{F}$ ).  
 • (N) indicates low noise resistor.  
 • Values in [ ] for coils and transformers are DC resistance.  
 • Voltage values shown are measured with a voltmeter (20k $\Omega$ /V).  
 In playback mode and without signal inputs.  
 Voltages in ( ) are for record mode.  
 Voltages marked with \* are measured with VTVM.

• Switch mode

Ref. No.	Switch	Mode
S101, 201	record/playback	playback
S102, 202	MONITOR (TAPE/SOURCE)	TAPE
S103	ED (TAPE SELECT) (NORMAL/SPECIAL)	NORMAL
S104	TAPE SPEED D (19 cm, 7 1/2/38 cm, 15)	19 cm, 7 1/2
S105, 206	MIC ATT (W/15/30)	0
S106	BIAS (TAPE SELECT) (LOW/HIGH)	LOW



# TC-756/TC-756-2

## 3-3. MOUNTING DIAGRAM – AMP SECTION

[Click here to view Amp circuit diagram](#)

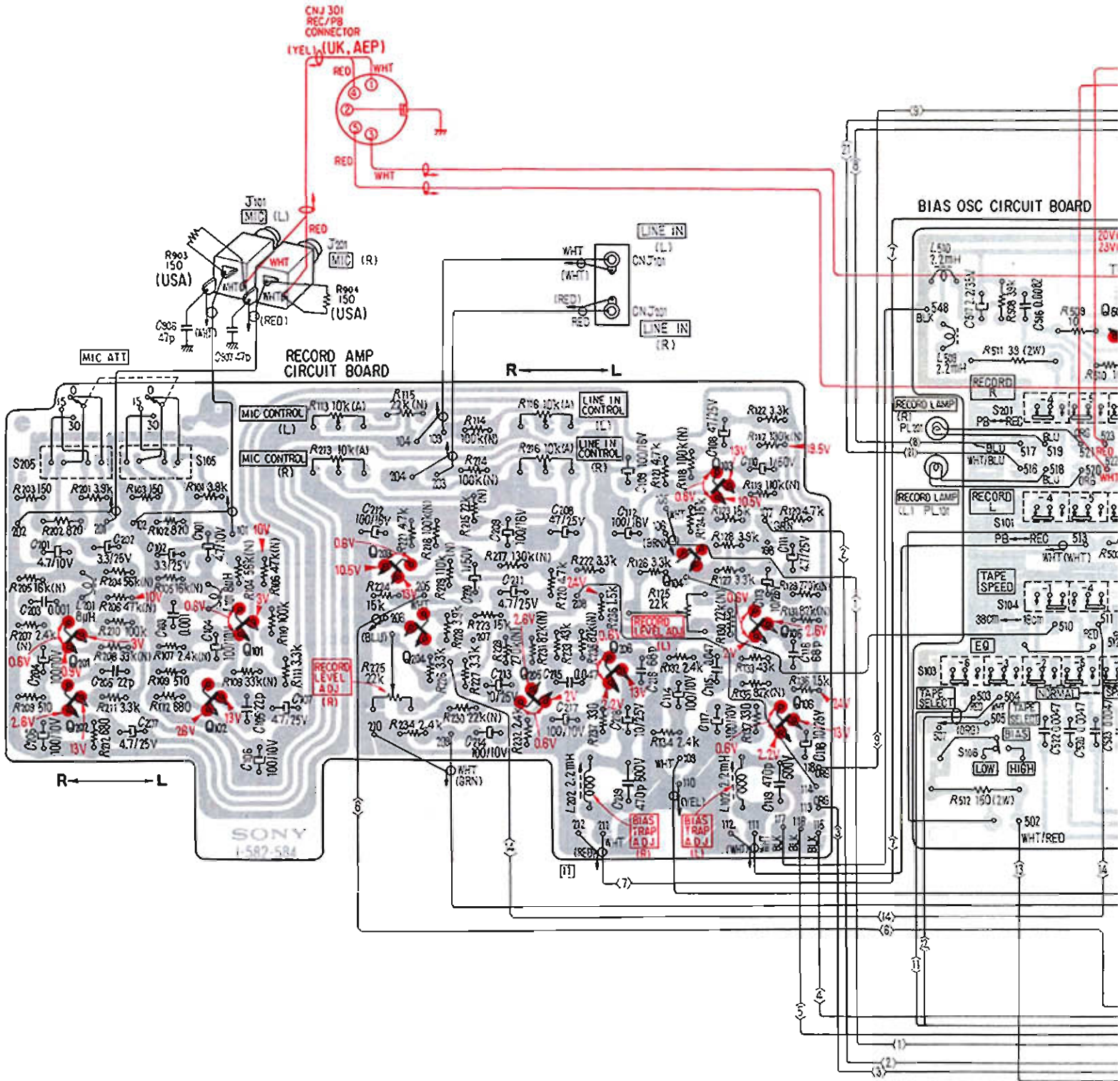

Q, IC	Q201 Q202	Q101 Q102	Q203 Q204	Q205	Q206	Q104 Q103	Q105 Q106	0
D								
ADJ			R113 R213		R116 R216			







2SC634A: Q104, 204, 105, 205  
 106, 206, 303, 403  
 304, 404, 305, 405  
 306, 406, 307, 407  
 501, 502

2SC1362: Q102, 202  
 302, 402

1T22: D301, 401, 302,  
 402, 303, 403

2SC631A: Q101, 103  
 201, 203

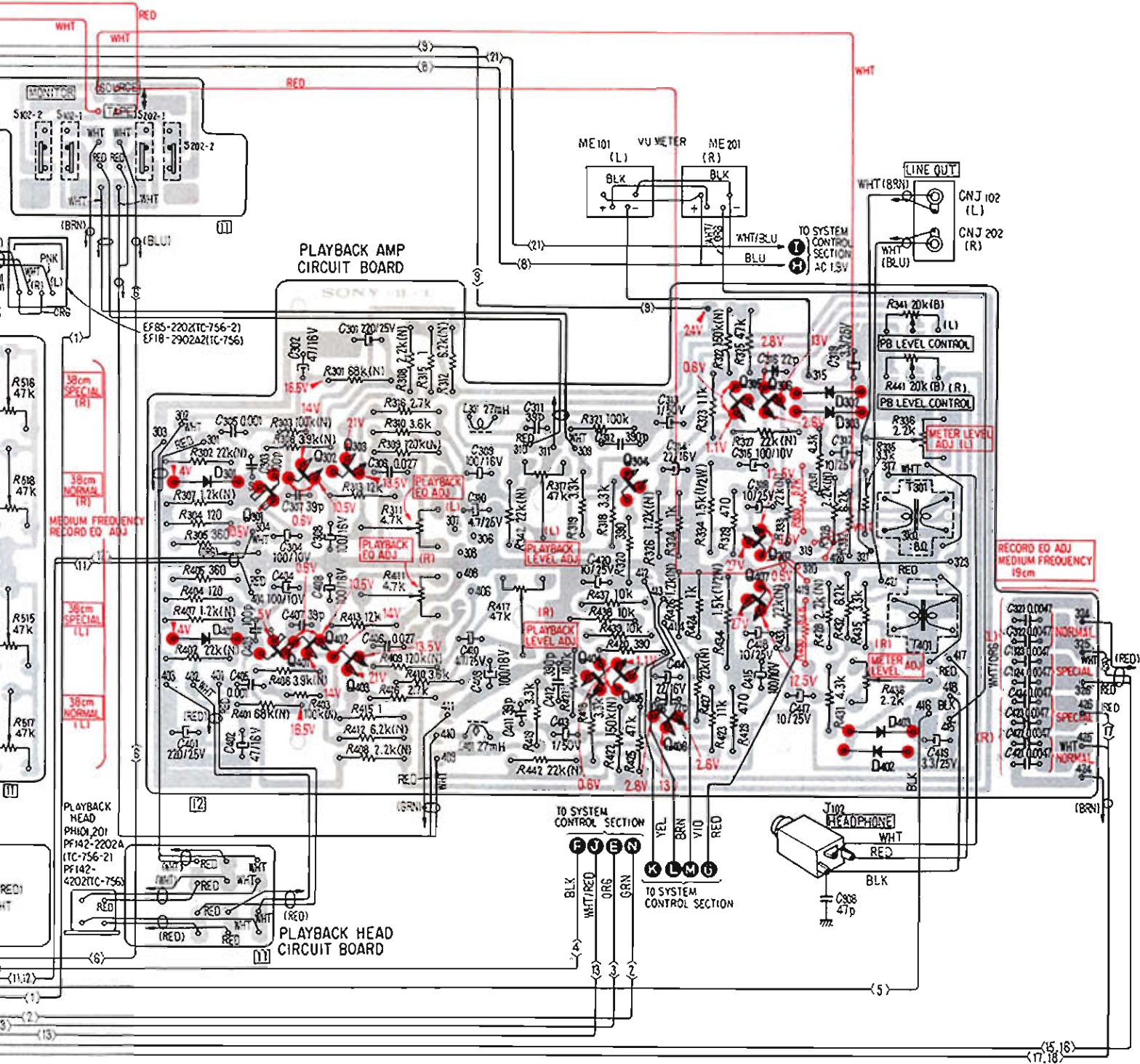
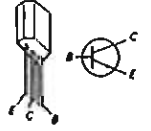
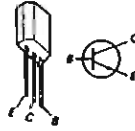
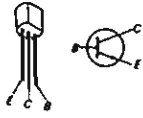

Q301	Q302	Q303	Q304	Q305	Q306
Q401	Q402	Q403	Q404	Q405	Q406
D301	D401				
		R311	R317	R341	R336
		R411	R417	R441	R436
				D302	D303
				D403	D402

516  
 518  
 515  
 517

3-4. MOUNTING DIAGRAM – SYSTEM CONTROL SECTION – Conductor Side –  
[click here to view system circuit diagram](#)

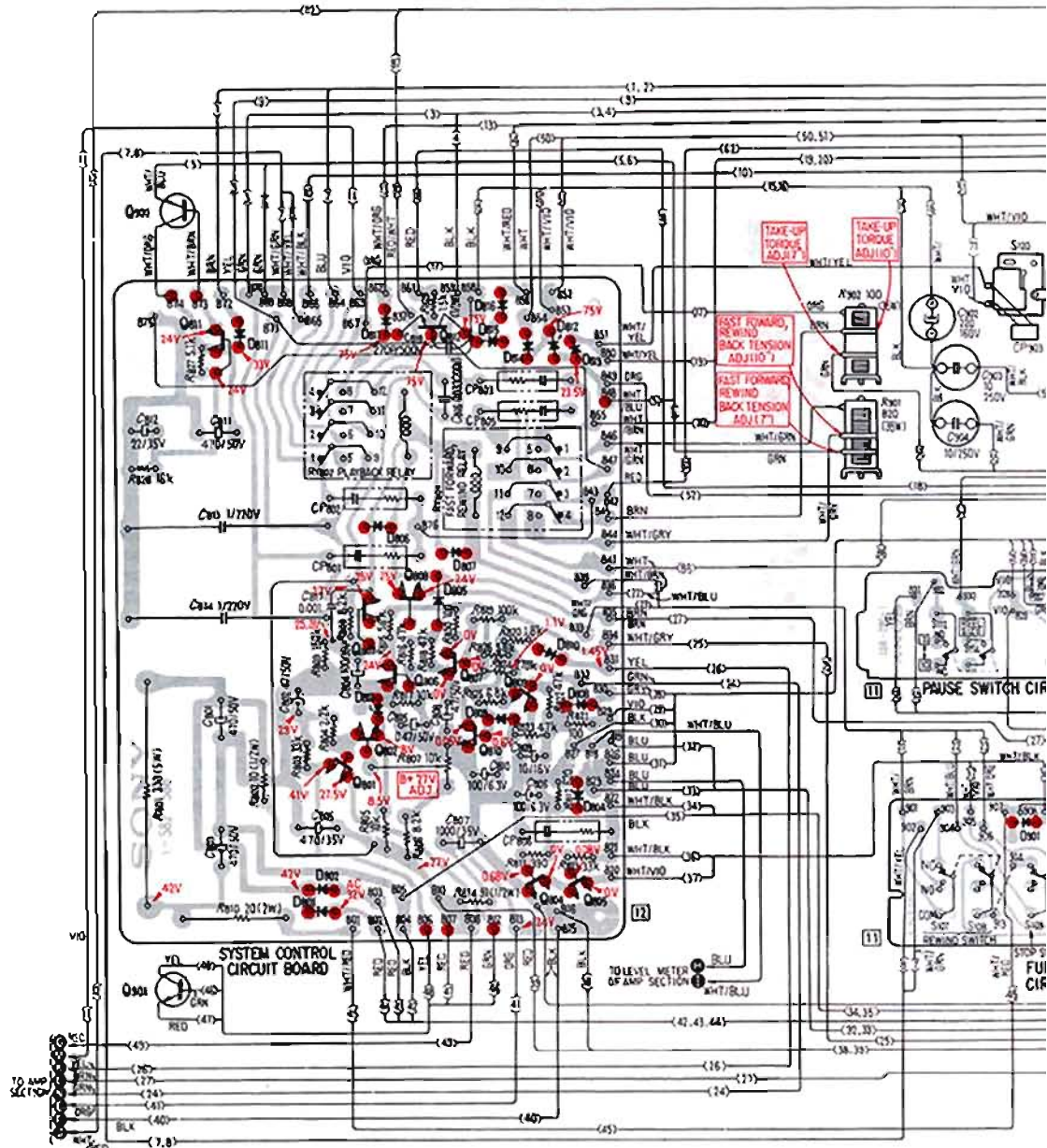

Q. IC	0902 0811	0803 0802	0804 0804	0812 0807	0809				
D	0811	0801	0817 0803	0807 0803	0810 0809	0804 0805	0816 0815	0812 0813	0901
ABJ									R702 R901

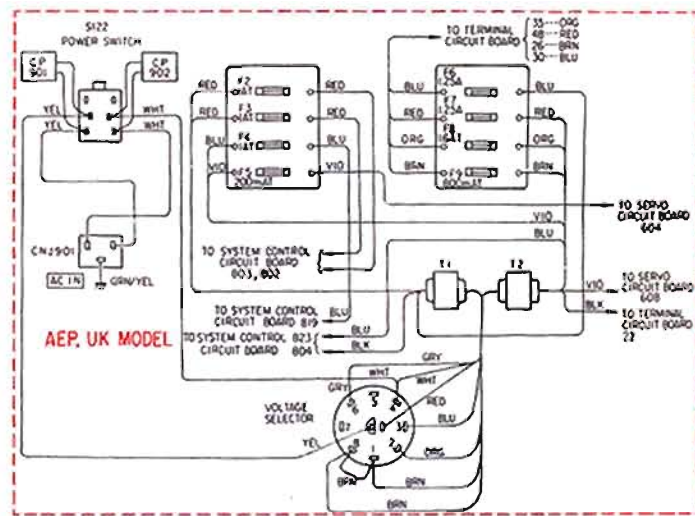

- ZSC634A: Q701-713  
 Q801-811  
 Q1001, 1002
- 
- ZSC1384: Q714
-



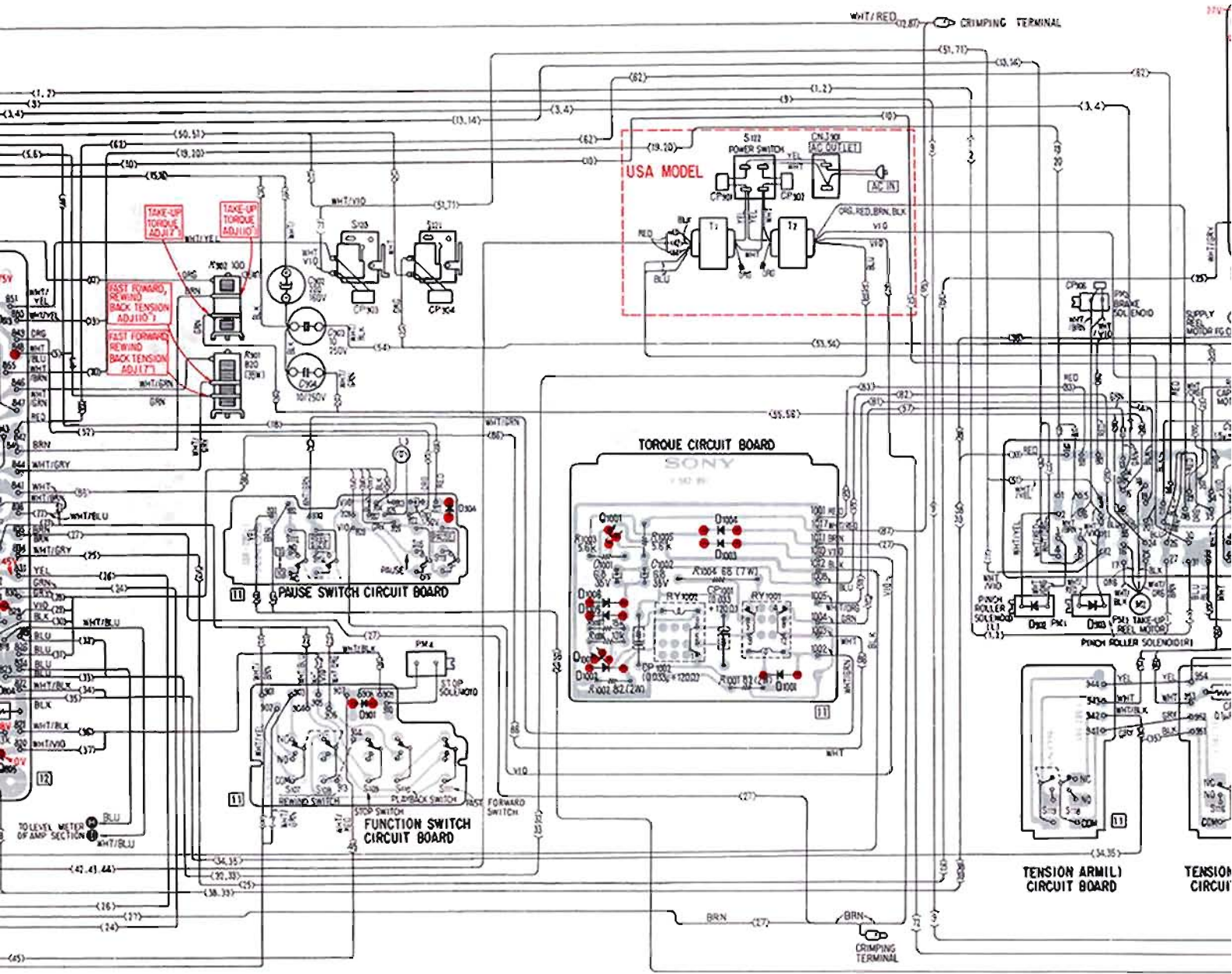

- D902
- R901
- D901
- D904
- D1006
- D1008
- D1002
- D1004
- D1003
- D1001
- D902
- D903

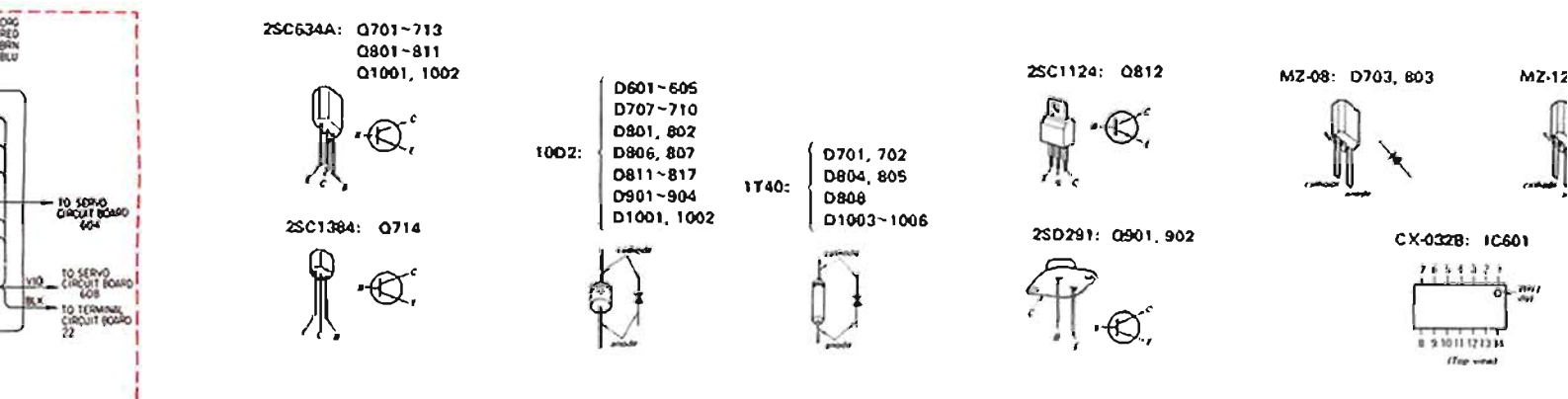

**ZSC634A:** Q701-713  
Q801-811  
Q1001, 1002

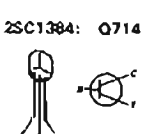
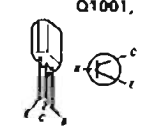

**1002:** D601-605  
D707-710  
D801, 802  
D806, 807  
D811-817  
D901-904  
D1001, 1002



**1T40:** D701, 702  
D804, 805  
D808  
D1003-1006



**ZSC1124:** Q812

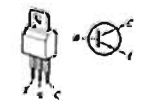

**2SD291:** Q901, 902



**MZ-08:** D703, 803



**CX-032B:** IC601

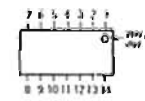

(Top view)





# TC-756/TC-756-2

## 3-5. SCHEMATIC DIAGRAM – SYSTEM CONTROL SECTION –

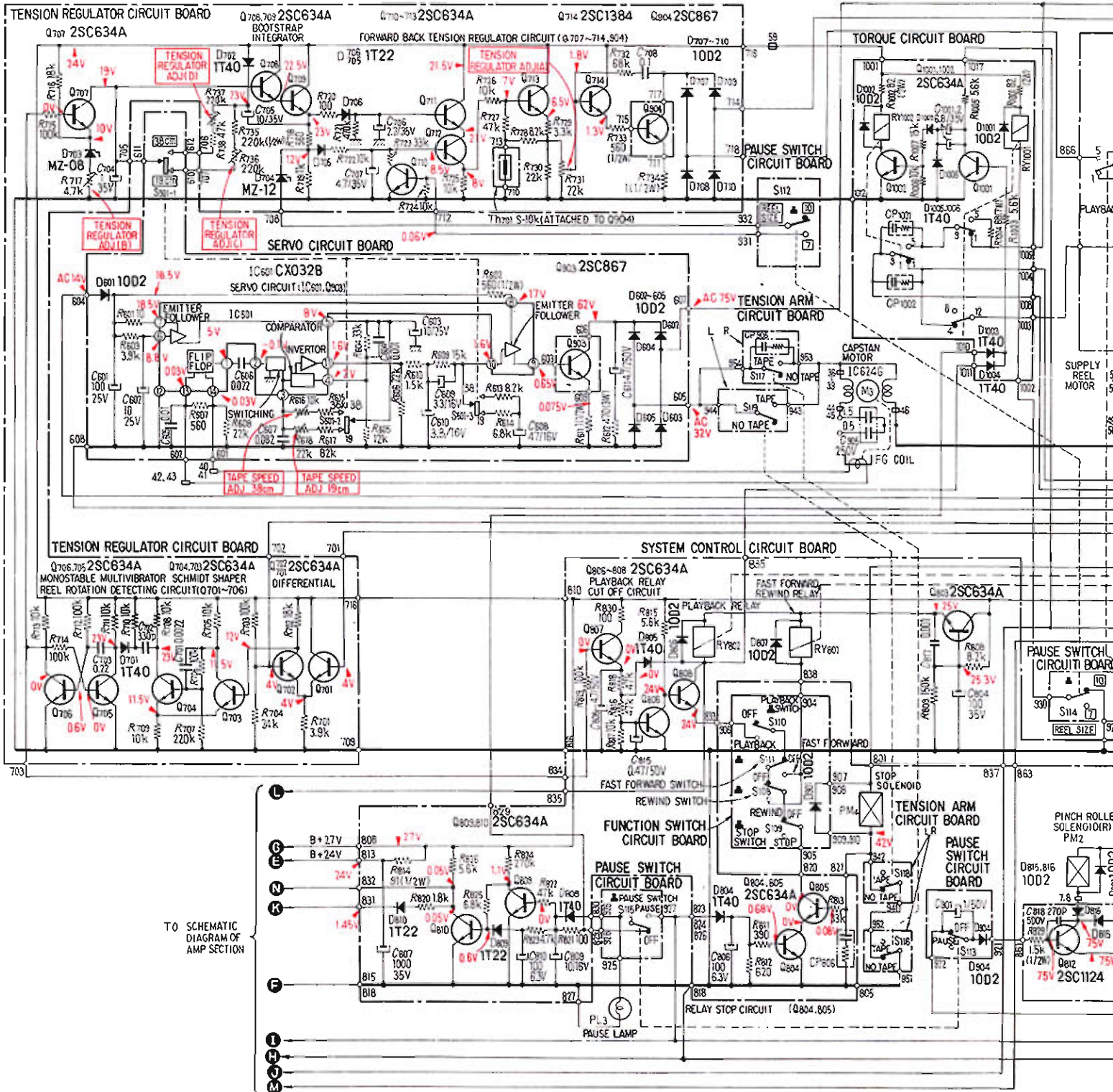















#### 4-5. EXPLODED VIEW (5)

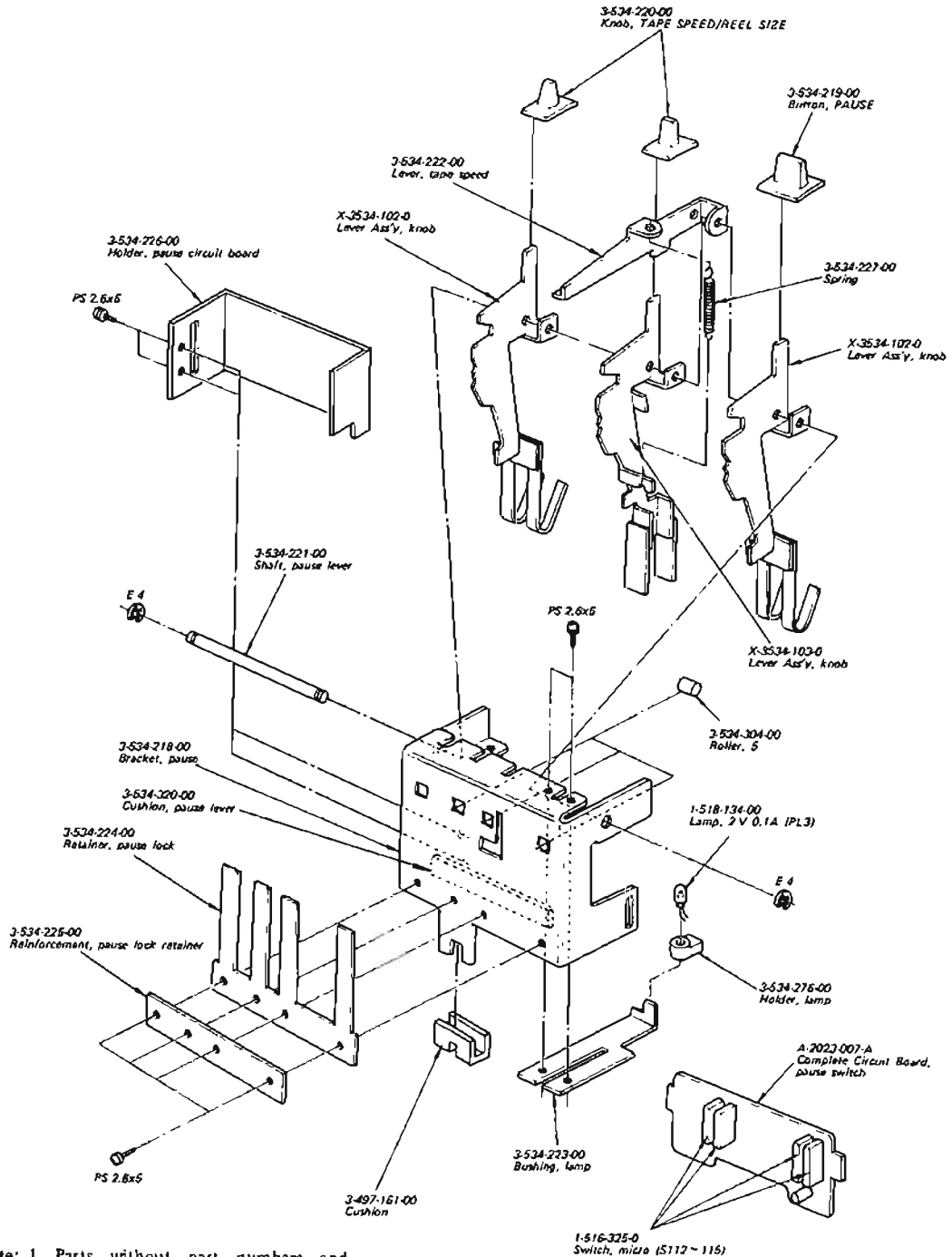

- Note: 1. Parts without part numbers and names are not available.  
 2. All screws are Phillips type (cross recess type) unless otherwise indicated.  
 (-): slotted head



### 4-7. EXPLODED VIEW (7)

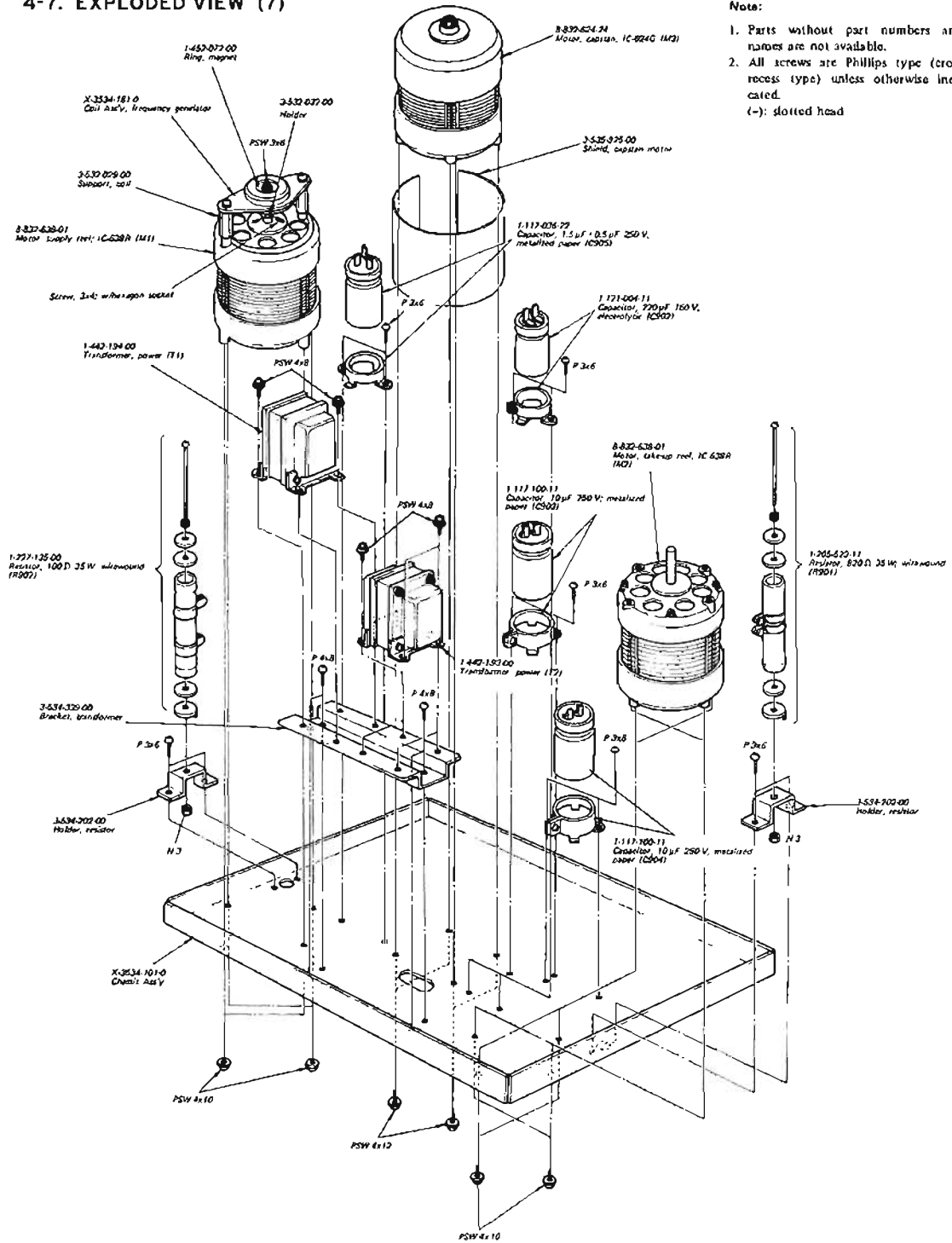

**Note:**

1. Parts without part numbers and names are not available.
  2. All screws are Phillips type (cross recess type) unless otherwise indicated.
- (-): slotted head









#### 4-11. PACKING

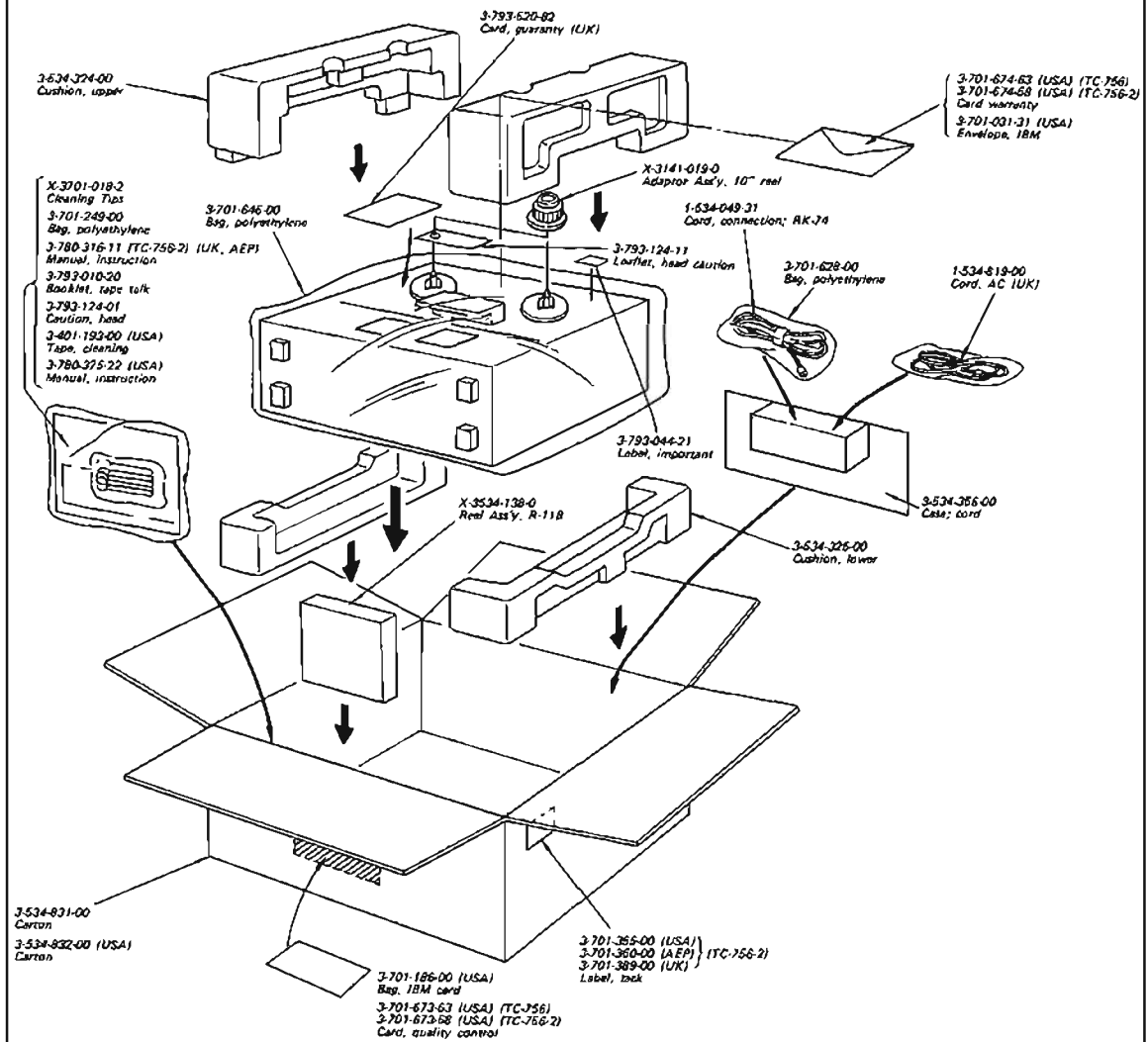

## SECTION 5 ELECTRICAL PARTS LIST

<u>Ref. No.</u>	<u>Part No.</u>	<u>Description</u>	<u>Ref. No.</u>	<u>Part No.</u>	<u>Description</u>
<b>COMPLETE CIRCUIT BOARDS</b>			Q901,902		Transistor 2SD291
	A-2014-001-A	Bias OSC	Q903,904		Transistor 2SC867
	A-2020-002-A	Servo	Q1001,1002		Transistor 2SC634A
	A-2023-007-A	Pause Switch	D301,401		Diode 1T22
	A-2095-015-A	Torque	D302,402		Diode 1T22
	A-2095-016-A	Tension Regulator	D303,403		Diode 1T22
	X-3534-147-0	Playback Amp	D601~605		Diode 10D2
	X-3534-148-0	Record Amp	D701,702		Diode 1T40
	X-3534-149-0	System Control	D703		Diode MZ-08
	X-3534-150-0	Tension Arm (R)	D704		Diode MZ-12
	X-3534-151-0	Tension Arm (L)	D705,706		Diode 1T22
	X-3534-152-0	MONITOR Switch	D707~710		Diode 10D2
	X-3534-153-0	Function Switch	D801,802		Diode 10D2
<b>CIRCUIT BOARDS</b>			D803		Diode MZ-08
	1-582-134-11	FG Coil	D804,805		Diode 1T40
	1-582-594-00	Head	D806,807		Diode 10D2
	1-582-864-00	Terminal	D808		Diode 1T40
<b>SEMICONDUCTORS</b>			D809,810		Diode 1T22
Q101,201		Transistor 2SC631A	D811~817		Diode 10D2
Q102,202		Transistor 2SC1362	D901~904		Diode 10D2
Q103,203		Transistor 2SC631A	D1001,1002		Diode 10D2
Q104,204		Transistor 2SC634A	D1003~1006		Diode 1T40
Q105,205		Transistor 2SC634A	IC601		Integrated Circuit CX-032B
Q106,206		Transistor 2SC634A	Th701	1-800-204-00	Thermistor S10K
Q301,401		FET 2SK43	<b>COILS</b>		
Q302,402		Transistor 2SC1362	L101,201	1-407-519-00	8 $\mu$ H, inductor
Q303,403		Transistor 2SC634A	L102,202	1-407-286-00	2.2 mH, variable inductor
Q304,404		Transistor 2SC634A	L301,401	1-407-593-00	27 mH, microinductor
Q305,405		Transistor 2SC634A	L501~504	1-407-268-00	1.5 mH, variable inductor
Q306,406		Transistor 2SC634A	L507,508	1-407-284-00	1 mH, variable inductor
Q307,407		Transistor 2SC634A	L509,510	1-407-198-00	2.2 mH, microinductor
Q501,502		Transistor 2SC634A	<b>TRANSFORMERS</b>		
Q701~713		Transistor 2SC634A	T1	1-442-192-00	Power
Q714		Transistor 2SC1384	T2	1-442-197-00	Power
Q801~811		Transistor 2SC634A	T301,401	1-427-299-00	Headphone
Q812		Transistor 2SC1124	T501	1-433-158-00	Bias Osc

Ref. No.      Part No.      Description

CAPACITORS

All capacitors are in  $\mu\text{F}$  unless otherwise indicated. (p =  $\mu\mu\text{F}$ , elect = electrolytic)

C101,201	1-131-192-11	4.7	10 V	tantalum
C102,202	1-121-392-11	3.3	25 V	elect
C103,203	1-105-821-12	0.001	50 V	mylar
C104,204	1-121-414-11	100	10 V	elect
C105,205	1-107-115-11	22 p	50 V	silvered mica
C106,206	1-121-414-11	100	10 V	elect
C107,207	1-121-915-11	4.7	25 V	elect
C108,208	1-121-410-11	47	25 V	elect
C109,209	1-121-415-11	100	16 V	elect
C110,210	1-121-391-11	1	50 V	elect
C111,211	1-121-915-11	4.7	25 V	elect
C112,212	1-121-415-11	100	16 V	elect
C113,213	1-121-748-11	10	25 V	elect
C114,214	1-121-414-11	100	10 V	elect
C115,215	1-105-681-12	0.047	50 V	mylar
C116,216	1-107-127-11	68 p	50 V	silvered mica
C117,217	1-121-414-11	100	10 V	elect
C118,218	1-121-398-11	10	25 V	elect
C119,219	1-107-016-11	470 p	500 V	silvered mica
C301,401	1-121-422-11	220	25 V	elect
C302,402	1-121-409-11	47	16 V	elect
C303,403	1-107-131-11	100 p	50 V	silvered mica
C304,404	1-121-414-11	100	10 V	elect
C305,405	1-105-661-12	0.001	50 V	mylar
C306,406	1-105-678-12	0.027	50 V	mylar
C307,407	1-107-121-11	39 p	50 V	silvered mica
C308,408	1-121-415-11	100	16 V	elect
C309,409				
C310,410	1-121-915-11	4.7	25 V	elect
C311,411	1-107-121-11	39 p	50 V	silvered mica
C312,412	1-107-242-11	390 p	50 V	silvered mica
C313,413	1-121-912-11	1	50 V	elect
C314,414	1-121-479-11	22	16 V	elect
C315,415	1-121-414-51	100	10 V	elect
C316,416	1-107-115-11	22 p	50 V	silvered mica
C317,417	1-121-398-11	10	25 V	elect
C318,418				
C319,419	1-121-392-11	3.3	25 V	elect
C420	1-121-398-11	10	25 V	elect
C321~324	1-105-669-12	0.0047	50 V	mylar
C421~424				

Ref. No.      Part No.      Description

C501,502	1-105-513-12	0.01	50 V	mylar
C503,504	1-105-517-12	0.022	50 V	mylar
C505,506	1-105-512-12	0.0082	50 V	mylar
C507,508	1-105-515-12	0.015	50 V	mylar
C509,510	1-107-163-11	47 p	500 V	silvered mica
C511	1-141-034-00	30~120 p		trimmer
C512		.....		
C513,514	1-129-992-11	0.0024	630 V	polyethylene
C515	1-105-719-12	0.033	100 V	mylar
C516	1-105-712-12	0.0082	100 V	mylar
C517	1-131-217-11	2.2	35 V	tantalum
C518	1-141-034-00	30~120 p		trimmer
C519		.....		
C520~523	1-105-509-12	0.0047	50 V	mylar
C601	1-121-935-11	100	25 V	elect
C602,603	1-121-398-11	10	25 V	elect
C604	1-105-661-12	0.001	50 V	mylar
C605	1-105-673-12	0.01	50 V	mylar
C606	1-105-677-12	0.022	50 V	mylar
C607	1-108-550-11	0.082	50 V	polyethylene
C608	1-121-409-11	47	16 V	elect
C609,610	1-131-197-11	3.3	16 V	tantalum
C611	1-121-900-11	4.7	250 V	elect
C701	1-105-665-12	0.0022	50 V	mylar
C702	1-102-112-11	330 p	50 V	ceramic
C703	1-105-529-12	0.22	50 V	mylar
C704	1-131-215-11	1	35 V	tantalum
C705	1-131-238-11	10	35 V	tantalum
C706	1-131-217-11	2.2	35 V	tantalum
C707	1-131-219-11	4.7	35 V	tantalum
C708	1-105-725-12	0.1	100 V	mylar
C801	1-121-983-11	470	50 V	elect
C802	1-121-411-11	47	50 V	elect
C803	1-121-810-11	470	50 V	elect
C804	1-121-357-11	100	35 V	elect
C805	1-121-361-11	470	35 V	elect
C806	1-121-980-11	100	6.3 V	elect
C807	1-121-388-11	1000	35 V	elect
C808	1-121-954-11	4.7	50 V	elect
C809	1-121-651-11	10	16 V	elect
C810	1-121-980-11	100	6.3 V	elect
C811	1-121-983-11	470	50 V	elect
C812	1-121-662-11	22	35 V	elect
C813,814	1-113-072-11	1	220 V	metalized paper

<u>Ref. No.</u>	<u>Part No.</u>	<u>Description</u>		<u>Ref. No.</u>	<u>Part No.</u>	<u>Description</u>	
C815	1-121-726-11	0.47	50 V elect	R129,229	1-242-731-09	270k	low noise
C816	1-105-919-12	0.033	200 V mylar	R130,230	1-242-705-09	22k	low noise
C817	1-105-821-12	0.001	50 V mylar	R131,231	1-242-719-09	82k	low noise
C818	1-107-179-11	270p	500 V silvered mica	R132,232	1-242-682-11	2.4k	
C901	1-121-391-11	1	50 V elect	R133,233	1-242-712-11	43k	
C902	1-121-004-11	220	160 V elect	R134,234	1-242-682-11	2.4k	
C903,904	1-117-100-11	10	250 V metalized paper	R135,235	1-242-719-09	82k	low noise
C905	1-117-036-22	1.5+0.5	250 V metalized paper	R136,236	1-242-677-11	1.5k	
C906~911	1-107-123-11	47p	50 V silvered mica	R137,237	1-242-661-11	330	
C1001,1002	1-131-239-61	6.8	35 V tantalum				

### RESISTORS

All resistors are 1/4W, carbon type and in  $\Omega$  unless otherwise indicated. (k = 1,000)

R101,201	1-242-687-11	3.9k		R301,401	1-244-717-09	6.8k	low noise
R102,202	1-242-671-11	820		R302,402	1-244-705-09	22k	low noise
R103,203	1-242-653-11	150		R303,403	1-242-721-09	100k	low noise
R104,204	1-242-715-09	56k	low noise	R304,404	1-244-651-11	120	
R105,205	1-242-702-09	16k	low noise	R305,405	1-244-662-11	360	
R106,206	1-242-713-09	47k	low noise	R306,406	1-244-687-09	3.9k	low noise
R107,207	1-242-682-09	2.4k	low noise	R307,407	1-244-675-09	1.2k	low noise
R108,208	1-242-709-09	33k	low noise	R308,408	1-244-681-09	2.2k	low noise
R109,209	1-242-666-11	510		R309,409	1-244-723-09	120k	low noise
R110,210	1-242-721-11	100k		R310,410	1-244-686-11	3.6k	
R111,211	1-242-685-11	3.3k		R311,411	1-222-773-00	4.7k	
R112,212	1-242-669-11	680		R312,412	1-244-692-09	6.2k	low noise
R113,213	1-224-339-00	10k (A), variable		R313,413	1-244-699-11	12k	
R114,214	1-242-721-09	100k	low noise	R314,414	-----		
R115,215	1-242-705-09	22k	low noise	R315,415	1-244-601-11	1	
R116,216	1-224-339-00	10k (A), variable		R316,416	1-244-683-11	2.7k	
R117,217	1-242-724-09	130k	low noise	R317,417	1-222-776-00	47k, adjustable	
R118,218	1-242-721-09	100k	low noise	R318,418	1-244-685-11	3.3k	
R119,219	1-242-722-09	110k	low noise	R319,419			
R120,220	1-242-689-11	4.7k		R320,420	1-244-663-11	390	
R121,221							
R122,222	1-242-685-11	3.3k		R321,421	1-244-721-11	100k	
R123,223	1-224-701-11	15k		R322,422	1-244-725-09	150k	low noise
R124,224							
R125,225	1-222-775-00	22k, adjustable		R323,423	1-244-698-11	11k	
R126,226	1-242-685-11	3.3k		R324,424	1-244-673-11	1k	
R127,227							
R128,228	1-242-687-11	3.9k		R325,425	1-244-713-11	47k	
				R326,426	1-244-675-09	1.2k	low noise
				R327,427	1-244-705-09	22k	low noise
				R328,428	1-244-681-09	2.2k	low noise
				R329,429	1-244-665-11	470	
				R330,430	1-244-695-11	8.2k	
				R331,431	1-244-688-11	4.3k	
				R332,432	1-244-692-11	6.2k	
				R333,433	1-244-705-09	22k	
				R334,434	1-244-877-11	1.5k	
				R335,435	1-244-685-11	3.3k	



<u>Ref. No.</u>	<u>Part No.</u>	<u>Description</u>	<u>Ref. No.</u>	<u>Part No.</u>	<u>Description</u>
R336,436	1-222-772-00	2.2k, adjustable	R712	1-242-721-11	100k
R341,441	1-224-338-00	20k (B), variable	R713	1-242-697-11	10k
R342,442	1-244-705-09	22k low noise	R714,715	1-242-721-11	100k
R437~439	1-244-697-11	10k	R716	1-242-703-11	18k
R501,502	1-242-645-11	68	R717	1-222-773-00	4.7k, adjustable
R503A	1-242-681-11	2.2k	R718	1-242-667-11	560
R503B	1-242-693-11	6.8k	R719	1-242-673-11	1k
R504	1-242-693-11	6.8k	R720	1-242-649-11	100
R505	-----		R721	1-242-737-11	470k
R506	1-242-681-11	2.2k	R722	1-242-697-11	10k
R507	1-242-617-11	4.7	R723	1-242-709-11	33k
R508	1-242-711-11	39k	R724~726	1-242-697-11	10k
R509,510	1-242-625-11	10	R727	1-242-713-11	47k
R511	1-206-477-11	39 2W metal oxide	R728	1-242-695-11	8.2k
R512	1-206-644-11	150 2W metal oxide	R729	1-242-685-11	3.3k
R515~518	1-222-776-00	47k, adjustable	R730	1-242-705-11	22k
R601	1-242-625-11	10	R731	1-222-775-00	22k, adjustable
R602	1-244-867-11	560 1/2W	R732	1-242-717-11	68k
R603	1-242-687-11	3.9k	R733	1-244-867-11	560 1/2W
R604	1-242-709-11	33k	R734	1-244-801-11	1 1/2W
R605	1-242-699-11	12k	R735	1-244-729-51	220k 1/2W
R606	1-242-705-11	22k	R736,737	1-222-778-00	220k, adjustable
R607	1-242-667-11	560	R738	1-242-713-11	47k
R608	1-242-705-11	22k	R801	1-206-775-11	330 5W metal oxide
R609	1-242-701-11	15k	R802	1-212-958-11	10 1/2W fuse
R610	1-242-677-11	1.5k	R803	1-242-709-11	33k
R611	1-244-801-11	1 1/2W	R804	1-242-681-11	2.2k
R612	1-206-717-11	470 3W metal oxide	R805	1-242-697-11	10k
R613	1-244-695-11	8.2k	R806	1-242-695-11	8.2k
R614	1-242-693-11	6.8k	R807	1-222-774-00	10k, adjustable
R615	1-242-710-11	36k	R808	1-242-695-11	8.2k
R616	1-222-774-00	10k, adjustable	R809	1-242-725-11	150k
R617	1-242-719-11	82k	R810	1-206-470-11	20 2W metal oxide
R618	1-222-775-00	22k, adjustable	R811	1-242-663-11	390
R701	1-242-687-11	3.9k	R812	1-242-668-11	620
R702	1-242-703-11	18k	R813	1-242-709-11	33k
R703	1-242-721-11	100k	R814	1-206-486-11	91 2W metal oxide
R704	1-242-706-11	24k	R815	1-242-691-11	5.6k
R705	1-242-697-11	10k	R816	1-242-713-11	47k
R706	1-242-721-11	100k	R817	1-242-697-11	10k
R707	1-242-729-11	220k	R818	1-242-713-11	47k
R708~711	1-242-697-11	10k	R819	1-242-721-11	100k
			R820	1-242-679-11	1.8k
			R821	1-242-649-11	100

<u>Ref. No.</u>	<u>Part No.</u>	<u>Description</u>
R822	1-242-713-11	47k
R823	1-242-689-11	4.7k
R824	1-242-731-11	270k
R825	1-242-693-11	6.8k
R826	1-242-691-11	5.6k
R827	1-242-690-11	5.1k
R828	1-242-702-11	16k
R829	1-244-877-11	1.5k 1/2W
R830	1-242-649-11	100
R901	1-205-523-11	820 35W wirewound
R902	1-227-135-00	100 35W wirewound, adjustable
R903,904	1-242-653-11	150 (USA)
R1001,1002	1-206-485-11	82 2W metal oxide
R1003	1-244-691-11	5.6k
R1004	1-217-343-11	68 7W wirewound
R1005	1-244-691-11	5.6k
R1006	1-244-697-11	10k
R1007	1-244-701-11	15k
<b>SWITCHES</b>		
S101,201	1-514-367-00	Slide, record/playback
S102,202	1-516-323-00	Slide, MONITOR
S103	1-516-323-00	Slide, TAPE SELECT
S104	1-514-976-00	Slide, TAPE SPEED
S105,205	1-516-410-00	Rotary Slide, MIC ATT
S106	1-516-325-00	Micro, BIAS (TAPE SELECT)
S107	1-516-325-00	Micro, rewind
S108	1-516-325-00	Micro, rewind
S109	1-516-325-00	Micro, stop
S110	1-516-325-00	Micro, playback
S111	1-516-325-00	Micro, fast forward
S112	1-516-325-00	Micro, REEL SIZE
S113	1-516-325-00	Micro, PAUSE
S114	1-516-325-00	Micro, REEL SIZE
S115	1-516-325-00	Micro, PAUSE
S116	1-516-309-00	Micro, tension arm R
S117	1-516-309-00	Micro, tension arm R
S118	1-516-309-00	Micro, tension arm L
S119	1-516-309-00	Micro, tension arm L
S120	1-516-309-00	Micro, PM1 drive
S121	1-516-309-00	Micro, PM3 drive
S122	1-516-277-00	Push, POWER
S501	1-514-673-00	Slide, TAPE SPEED
<b>ENCAPSULATED COMPONENTS, C-R</b>		
CP101,102	1-231-057-31	0.033 μF+120 Ω, 500 V
CP801~803	1-231-057-31	0.033 μF+120 Ω, 500 V
CP804		.....
CP805,806	1-231-057-31	0.033 μF+120 Ω, 500 V
CP901~906	1-101-534-31	0.1 μF+120 Ω, 500 V

<u>Ref. No.</u>	<u>Part No.</u>	<u>Description</u>
<b>JACKS</b>		
J101,201	1-507-376-00	Phone, MIC
J301	1-507-414-00	Binaural, HEADPHONE
CN901	1-509-482-00	Socket, voltage selector
CNJ101,201	1-507-349-00	2P PHONE LINE IN/LINE OUT
CNJ102,202		
CNJ301	1-509-359-00	Connector, REC/PB (AEP, UK)
CNJ901	1-509-546-00	Connector, 3P AC IN (AEP,UK)
	1-509-341-00	Connector, AC Outlet (USA)
<b>MISCELLANEOUS</b>		
EH	8-825-547-00	Head, erase; EF18-2902A2 (TC-756)
	8-828-522-20	Head, erase; EF85-2202 (TC-756-2)
M1	8-832-638-01	Motor, supply reel; IC-638R
M2	8-832-638-01	Motor, take-up reel; IC-638R
M3	8-832-624-24	Motor, capstan; IC-624G
ME1,2	1-520-139-21	Meter, VU
PL101~103	1-518-134-00	Lamp, 2V 0.1A
PH	8-825-557-00	Head, playback; PF142-2202A (TC-756-2)
	8-825-636-00	Head, playback; PF142-4202 (TC-756)
PM1	1-454-074-00	Solenoid, punch roller (L)
PM2	1-454-074-00	Solenoid, pinch roller (R)
PM3	1-454-074-00	Solenoid, brake
PM4	1-454-073-21	Solenoid, stop
RH	8-825-558-00	Head, record; RF142-2202A (TC-756-2)
	8-825-511-00	Head, record; RF140-2902 (TC-756)
RY801	1-515-127-00	Relay, fast forward/rewind
RY802	1-515-127-00	Relay, playback
RY1001	1-515-127-00	Relay, torque circuit
RY1002		
F1	1-532-259-00	Fuse, 1.6AT
F2-4	1-532-078-00	Fuse, 1AT
F5	1-532-074-00	Fuse, 200 mAAT
F6,7	1-532-296-00	Fuse, 1.25A
F8,9	1-532-259-00	Fuse, 1.6AT
	1-533-105-00	Holder, fuse
	1-452-072-00	Ring, magnet
	1-534-819-00	Cord, power (UK)
	1-535-506-21	Terminal, crimping
	1-536-395-00	Terminal Strip, 1L)

## SECTION 6 HARDWARE

<u>Part No.</u>	<u>Description</u>	<u>Part No.</u>	<u>Description</u>
<b>SCREWS</b>			
All screws are Phillips type (cross recess type) unless otherwise indicated. (-): slotted head			
7-621-209-00	P 2.6 x 8	7-682-959-01	PSW 4 x 6
7-621-259-32	P 2.6 x 5	7-682-962-01	PSW 4 x 10
7-621-712-65	2.6 x 8, set; cone point	7-683-238-21	3 x 4, w/hexagon socket (cup point)
7-628-253-05	PS 2.6 x 5	7-683-240-21	3 x 6, w/hexagon socket (cup point)
7-628-253-95	PS 2.6 x 4		
7-682-123-01	P 2 x 3	7-685-145-21	P 3 x 6, self-tapping
7-682-124-01	P 2 x 4	7-685-145-31	P 3 x 6, self-tapping
7-682-128-01	P 2 x 10	7-685-158-31	P 4 x 6, self-tapping
7-682-147-07	P 3 x 6, cup point		
7-682-148-01	P 3 x 8,	<b>WASHERS</b>	
		7-623-105-12	2 (medium)
7-682-164-01	P 4 x 4	7-623-107-11	2.6 (medium)
7-682-165-01	P 4 x 16	7-623-110-12	4 (medium)
7-682-169-01	P 4 x 35	7-623-204-11	2, spring
7-682-247-01	4 x 6, flat point	7-623-207-21	2.6, spring (middle)
7-682-348-04	RK 3 x 8		
7-682-369-04	RK 4 x 35	<b>RETAINING RINGS</b>	
		7-624-102-01	E 1.5
7-682-546-05	B 3 x 5	7-624-104-01	E 2
7-682-547-04	B 3 x 6	7-624-106-01	E 3
7-682-625-01	PS 2 x 5	7-624-108-01	E 4
7-682-646-01	PS 3 x 5	7-624-109-01	E 5
7-682-647-01	PS 3 x 6		
7-682-648-01	PS 3 x 8	7-622-210-02	Nut 4
		7-682-013-00	Nut 3
7-682-947-01	PSW 3 x 6	7-623-508-01	Lug 3
7-682-948-01	PSW 3 x 8		

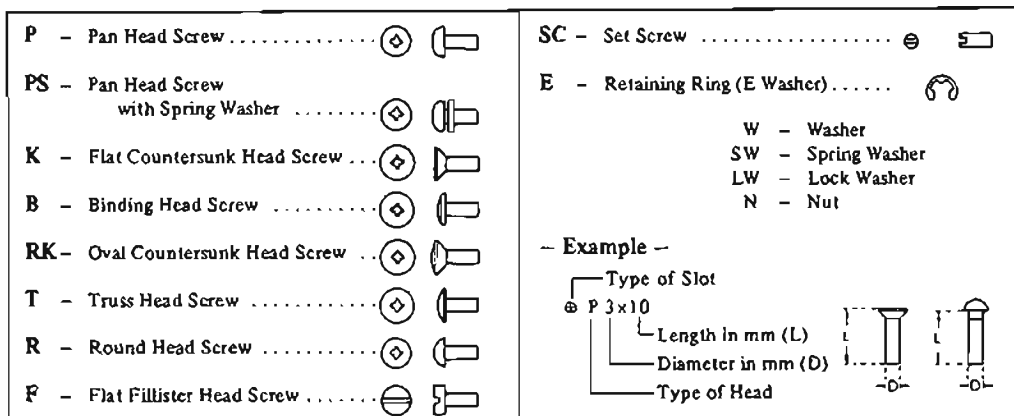

3-1 (B). LEVEL DIAGRAMS (TC-756)

Note: The level diagrams for TC-756-2: on page 26.

Playback Mode

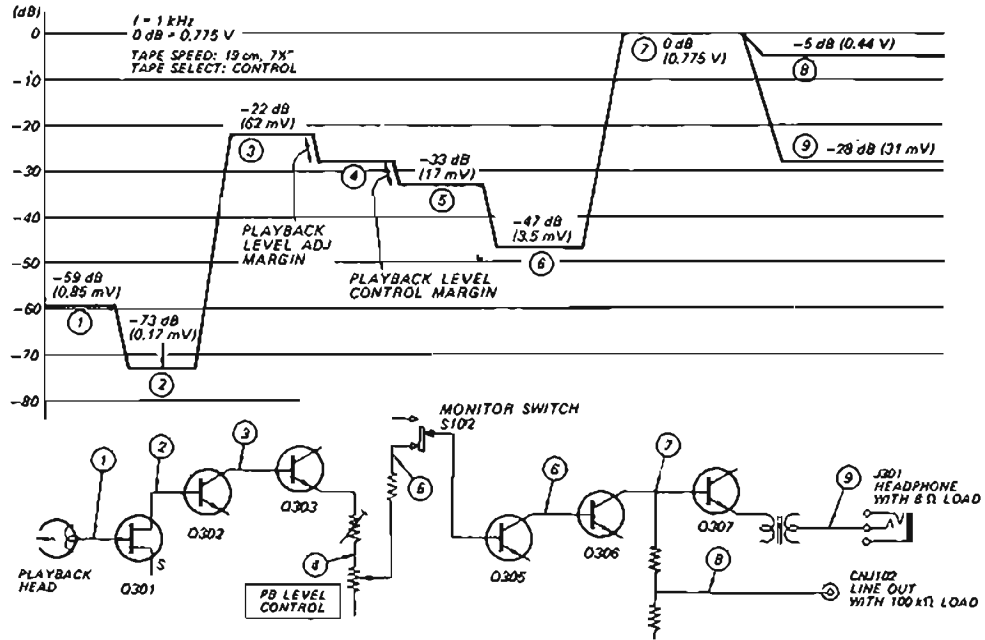

Record Mode

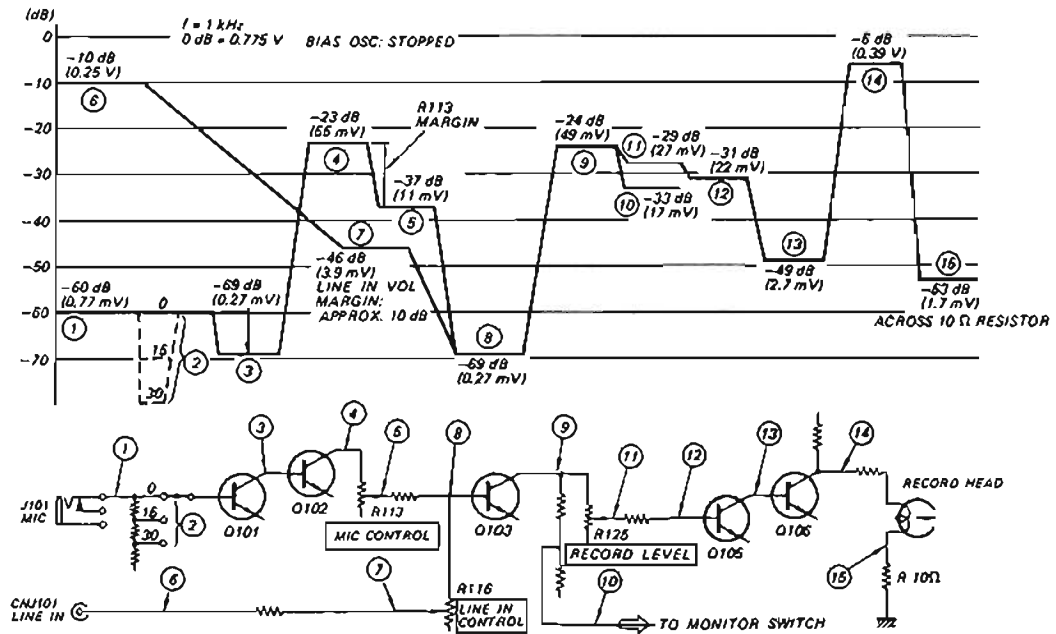

Sony Corporation

© 1974