

# TC-766-2

*UK Model  
AEP Model  
US Model  
Canadian Model*



## STEREO TAPE DECK

### SPECIFICATIONS

#### GENERAL

<b>Power Requirements:</b>	120V ac, 60 Hz (US, Canadian model) 110V, 120V, 220V, 240V ac, 50/60 Hz (UK, AEP model)
<b>Power Consumption:</b>	110W (US, Canadian model) 90W (UK, AEP model)
<b>AC Outlet:</b>	300W, unswitched (US, Canadian model)
<b>Dimensions:</b>	Approx. 445 (w) x 525 (h) x 235 (d) mm 17 $\frac{1}{2}$ (w) x 20 $\frac{5}{8}$ (h) x 9 $\frac{1}{4}$ (d) inches including projecting parts and controls
<b>Weight:</b>	26.5 kg, 58 lb 7 oz (US, Canadian model) 27 kg, 58 lb 8 oz (UK, AEP model)
<b>Track:</b>	2-track 2-channel stereo recording and playback 4-track 2-channel stereo playback
<b>Tape Speed:</b>	38 cm/s (15 ips) 19 cm/s (7 $\frac{1}{2}$ ips)

#### Fast Forward

**Rewind Time:** Approx. 150 seconds with 740 m (2,400 ft) tape

**Recording Time:** With 1,100 m (3,600 ft), 27 cm reel  
Stereo recording  
45 minutes at 38 cm/s  
Mono recording  
180 minutes at 19 cm/s

**Heads:** Record head 1, Playback head 2  
Erase head 1

**Motors:** AC servo-controlled capstan motor 1  
Induction reel motor 2

**Reel:** Up to 27 cm (10 $\frac{1}{2}$ -inch)

— Continued on page 2 —

#### SAFETY-RELATED COMPONENT WARNING!!

COMPONENTS IDENTIFIED BY SHADING ON THE SCHEMATIC DIAGRAMS AND IN THE PARTS LIST ARE CRITICAL TO SAFE OPERATION. REPLACE THESE COMPONENTS WITH SONY PARTS WHOSE PART NUMBERS APPEAR AS SHOWN IN THIS MANUAL OR IN SUPPLEMENTS PUBLISHED BY SONY.

**SONY**<sup>®</sup>  
**SERVICE MANUAL**

# TC-766-2

**Frequency Response:** With Sony Ferri-Chrome tape  
30–30,000 Hz  $\pm$  3 dB at 38 cm/s  
30–25,000 Hz  $\pm$  3 dB at 19 cm/s  
With SLH tape  
30–30,000 Hz  $\pm$  3 dB at 38 cm/s  
30–25,000 Hz  $\pm$  3 dB at 19 cm/s  
With regular tape  
30–22,000 Hz  $\pm$  3 dB at 38 cm/s  
30–18,000 Hz  $\pm$  3 dB at 19 cm/s

**Wow and Flutter:** NAB  
0.018% WRMS at 38 cm/s  
0.04% WRMS at 19 cm/s  
DIN  
 $\pm$  0.035% at 38 cm/s  
 $\pm$  0.07% at 19 cm/s

**S/N Ratio:** 64 dB (NAB) with Sony Ferri-Chrome Tape  
64 dB (DIN 1975 rev.) with Sony  
Ferri-Chrome Tape  
59 dB (DIN, old)

**Total Harmonic Distortion:** 0.5%

**Bias Frequency:** 160 kHz

**Equalization:** 3,180  $\mu$ S + 50  $\mu$ S

**Inputs:** MIC (two phone jacks)  
Sensitivity: 0.2 mV (-72 dB)  
Impedance: for low-impedance microphone  
LINE IN (two phono jacks)  
Sensitivity: 0.06 V (-22 dB)  
Impedance: 100 k $\Omega$   
REC/PB (connector) (UK, AEP model)  
Input impedance: less than 10 k $\Omega$

**Outputs:** LINE OUT (two phono jacks)  
Normal level: 0.435 V (-5 dB) with PB LEVEL  
control set to center detent position  
0.775 V (0 dB) with PB LEVEL  
control set to "10"  
Load impedance: 100 k $\Omega$   
Suitable load impedance: more than 10 k $\Omega$   
HEADPHONES (binaural jack)  
Load impedance: for low-impedance headphones  
REC/PB (connector) (UK, AEP model)  
Output impedance: less than 10 k $\Omega$

**Other Jack:** 11-pin remote control connector

0 dB = 0.775 V

## MODEL IDENTIFICATION

### Specification label

UK, AEP model

<b>SONY</b>	
TAPECORDER	TC-766-2
110.120.220.240V	~ 50/60Hz 90 W
NO.	
MADE IN JAPAN	

US model

<b>SONY</b>	
TAPECORDER	TC-766-2
AC 120V	60Hz 110 W
NO.	
MADE IN JAPAN	

Canadian model

<b>SONY</b>	
TAPECORDER	TC-766-2
AC 120V	60Hz 110 W
NO.	
MADE IN JAPAN	

SECTION 1  
OUTLINE

1-1. BLOCK DIAGRAM - System Control Section -

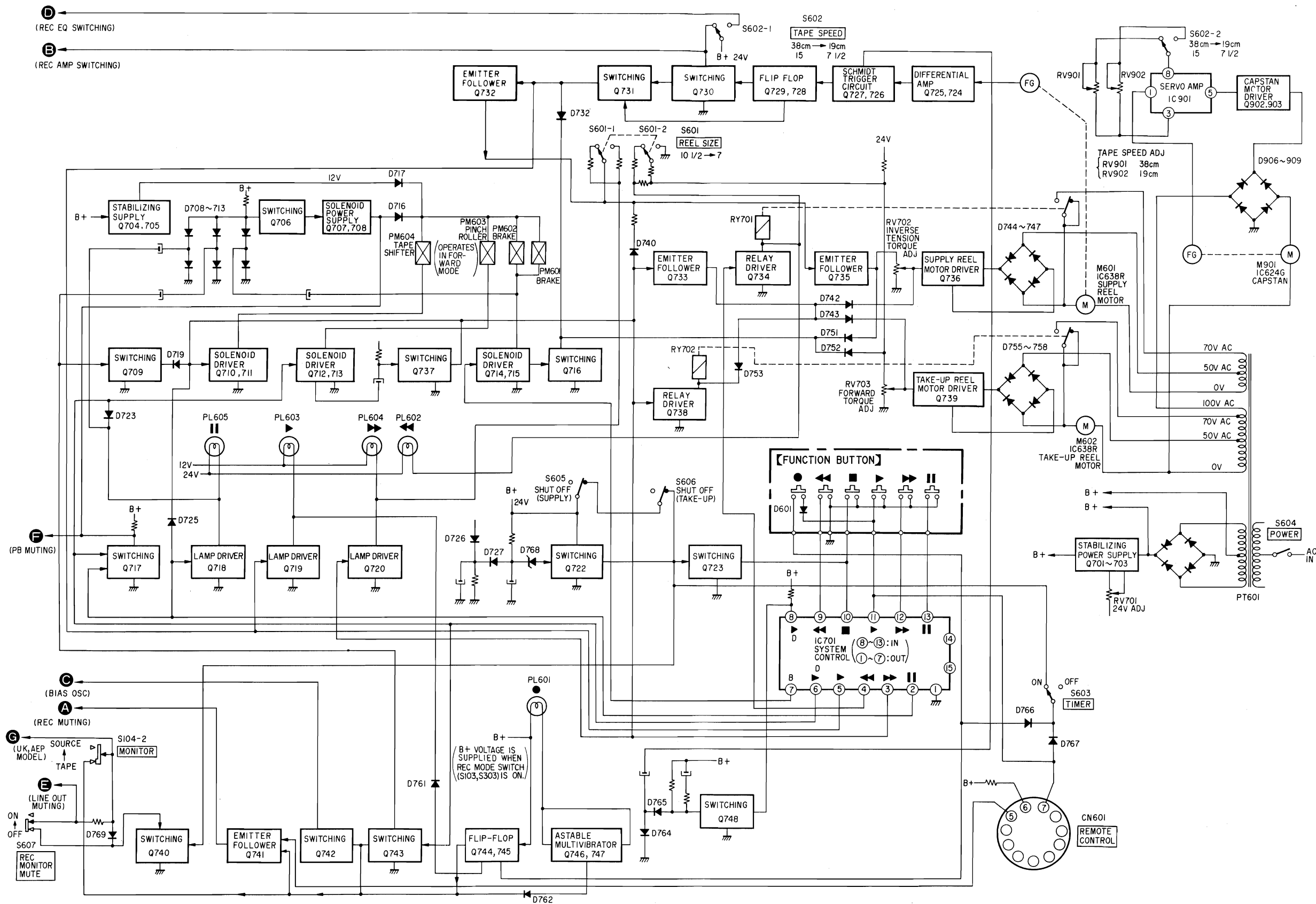





# TC-766-2 TC-766-2

## 1-2. BLOCK DIAGRAM – Amplifier Section –

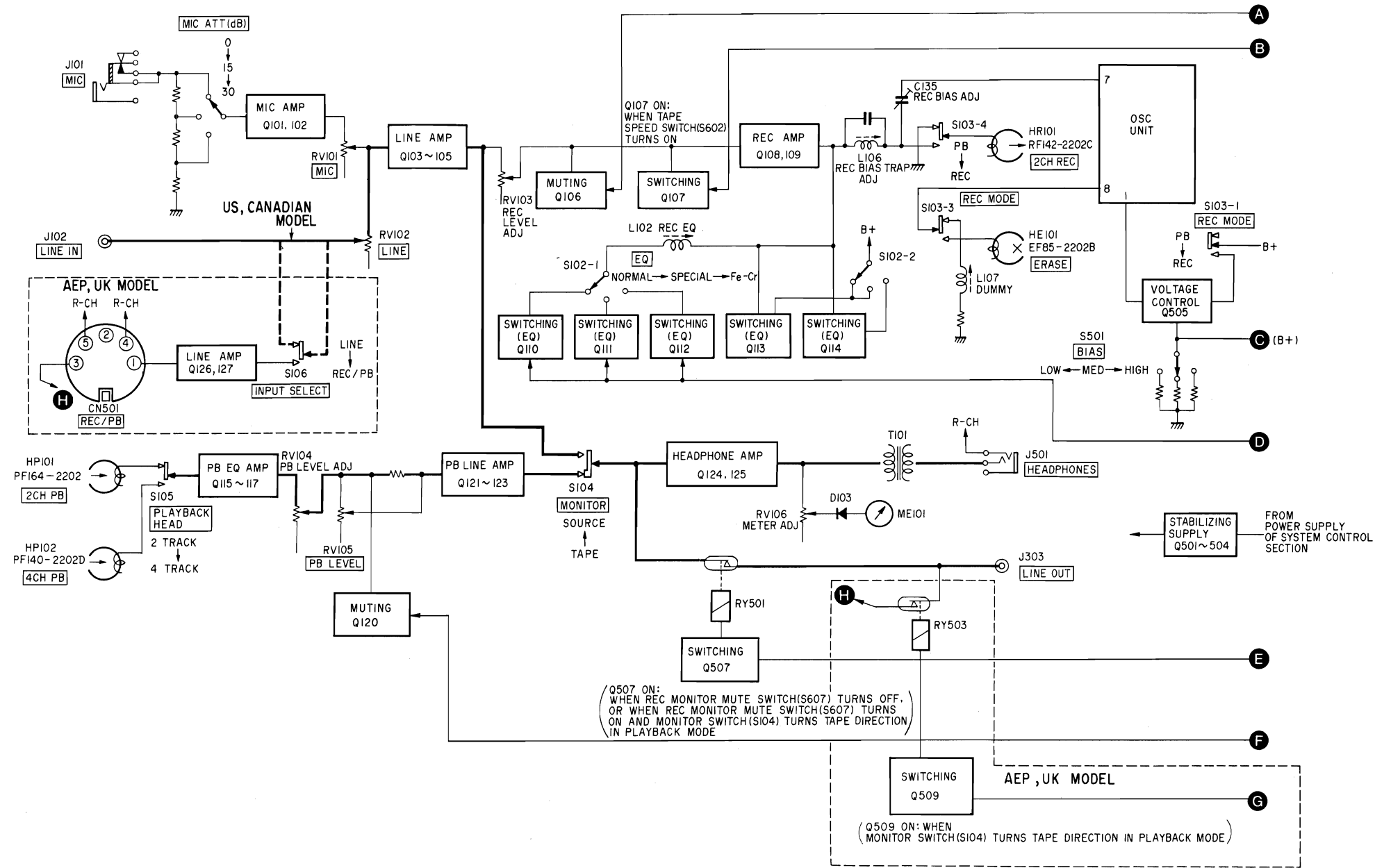



SECTION 2  
DISASSEMBLY

1-3. NOTE ON REPAIRING

NOTE ON REPAIRING

- This set does not change playback level when TAPE SELECT switches are changed.
- The LINE OUT signal is cut when REC MONITOR MUTE switch (S607) on the rear panel is turned ON except when MONITOR switch is in TAPE position in playback mode.
- If TIMER switch is previously set to ON position, it may happen to erase test tapes because the set becomes automatically in the auto playback (awakening) or auto record mode determined by REC MODE switch position when POWER switch is turned ON.
- PB LEVEL controls on the front panel control LINE OUT and HEADPHONES levels, and also VU meters indicate the amount of PB LEVEL controlling. When PB LEVEL is in the center-click positions, LINE OUT levels are standard 0.44V (-5dB) and VU meters indicate "0". When PB LEVEL controls are in their full-clockwise stops, LINE OUT levels are 0.775V (0dB).
- Three kinds of hexagonal-socket screwdrivers are needed for the following adjustment/removal.

Screwdriver	Adjustment/removal
 1.27 mm	Tension-arm pin Intermediate pin Switch knob Switch lever
 1.5 mm	Head azimuth FG-holding boss Control knob
 2.0 mm	Motor pulley Reel drum

- Tape BIAS/EQ recommendations  
The following list shows the recommended settings, which have been determined through critical listening tests and electrical characteristic measurements on commercially available tapes. The setting can be changed according to the personal preference. For Sony tapes, be sure to use the recommended settings to obtain the optimum tape characteristics.

EQ	NORMAL	SPECIAL	Fe-Cr
BIAS			
LOW	SONY PR	BASF LH, LHS AGFA PE, PEM MEMOREX	SCOTCH #211, #212, #213 AMPEX 406, 407
MED	SCOTCH #218	SONY SLH SCOTCH CLASSIC TDK AUDUA	SONY DUAD SCOTCH #206, #207 MAXELL UD
HIGH			SCOTCH #250

- |                                    |               |  |
|------------------------------------|---------------|--|
| Reel Panel Removal:                | ①, ②          | (to Mechanical Adjustment)                       |
| Amp Panel Removal:                 | ③, ④, ⑤, ⑥, ⑦ | (to VU Meter and Variable Resistor Replacement)  |
| Perforated Panel (top) Removal:    | ⑧, ⑨          | (to Fuse Replacement)                            |
| Perforated Panel (bottom) Removal: | ⑩, ⑪          | (to Audio Amp Board Check)                       |
| Side Board (right) Removal:        | ⑫, ⑬          | (to Tape Speed and Forward Torque Adjustments)   |
| Side Board (left) Removal:         | ⑭, ⑮          | (to B+ and Supply Reel Back Tension Adjustments) |
| Rear Board Removal:                | ⑯, ⑰          | (to System Control Board Checking)               |

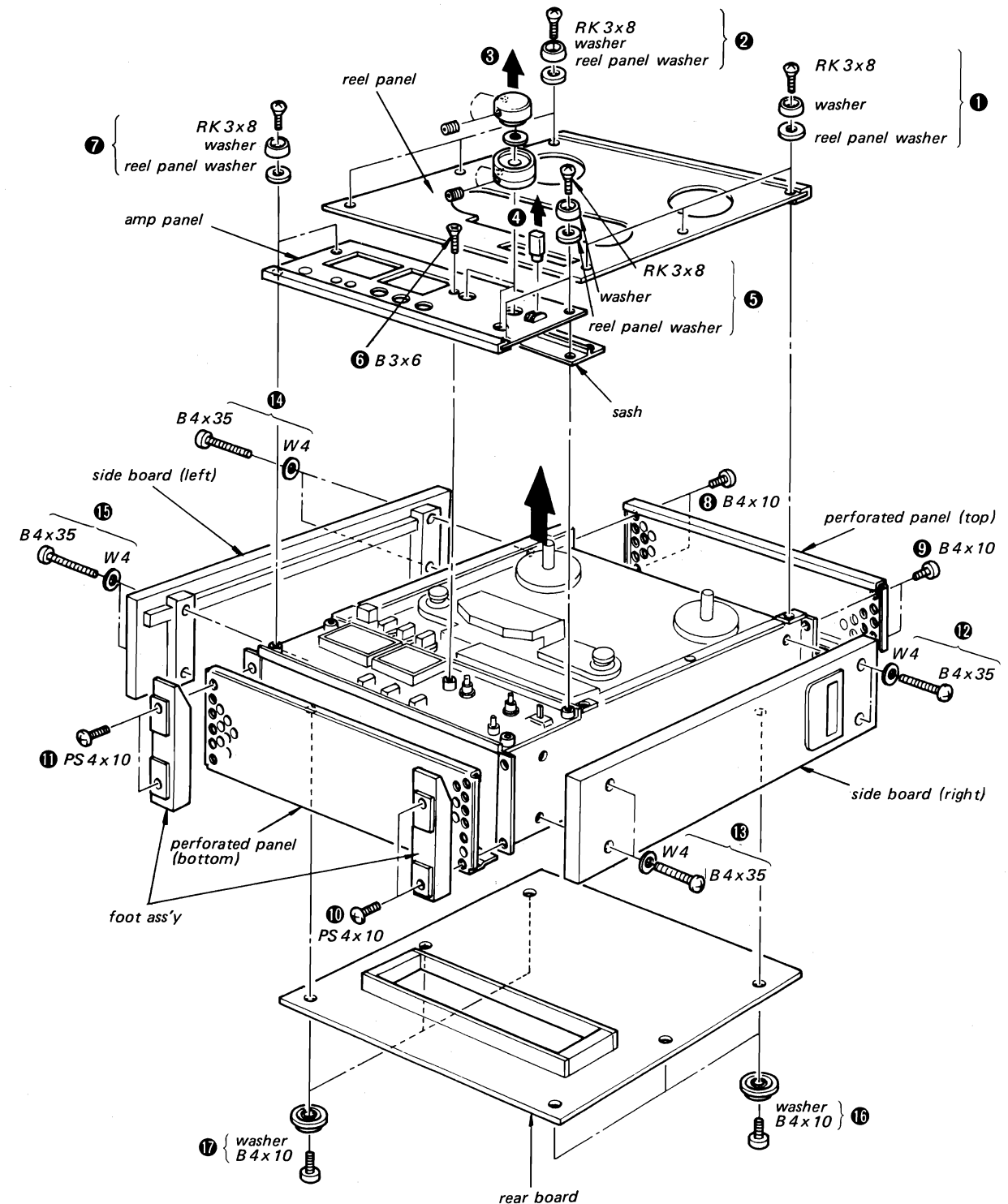

TENSION ARM BASE REMOVAL

Microswitch Installation

Turn the tension lever and adjust the position of the microswitch for the specified clearance when it switches.

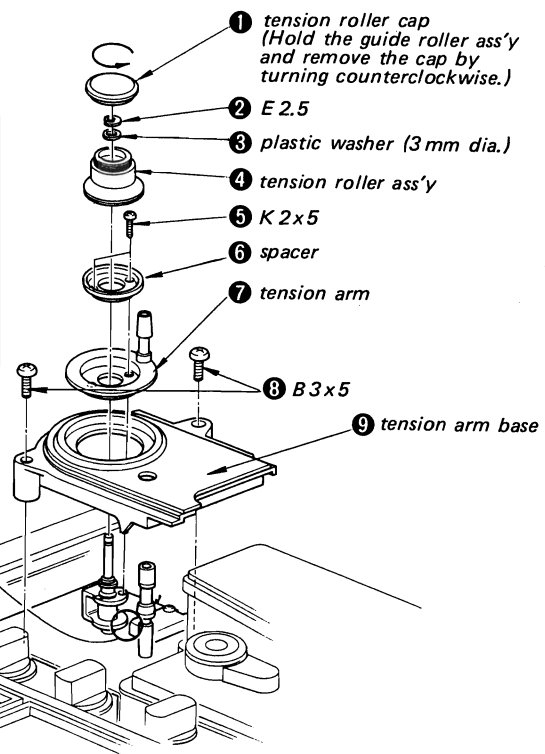
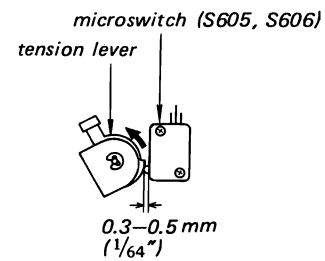

REEL TABLE REMOVAL

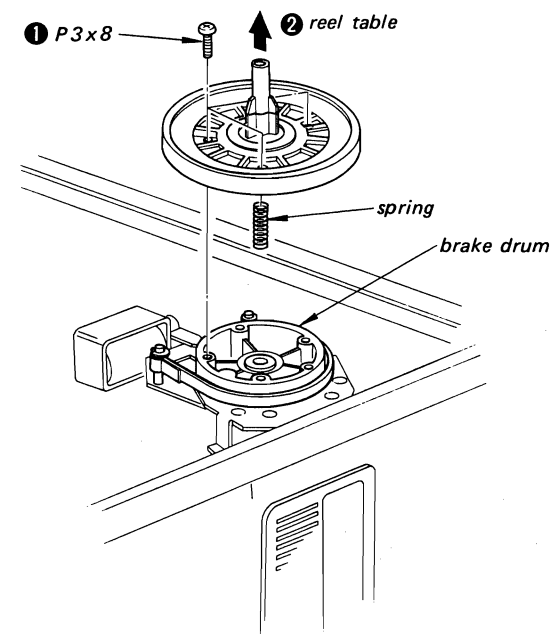

HEAD COVER REMOVAL

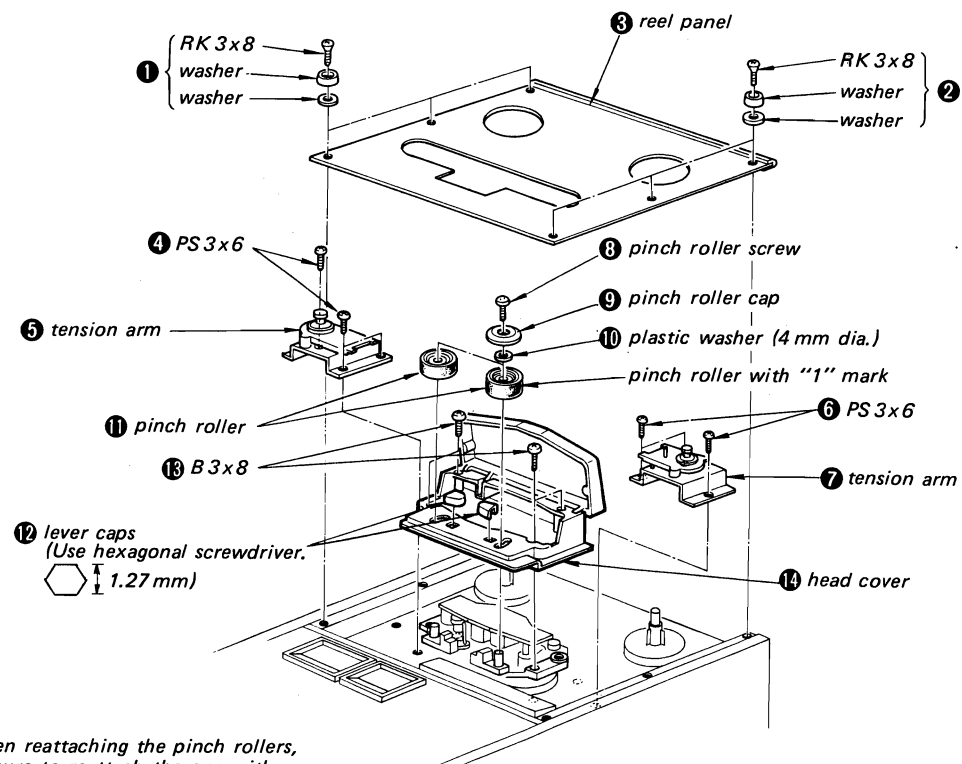

Note: When reattaching the pinch rollers, be sure to reattach the one with "1" mark at the right side.

MOTOR PULLEY INSTALLATION

Use a hexagonal screwdriver.

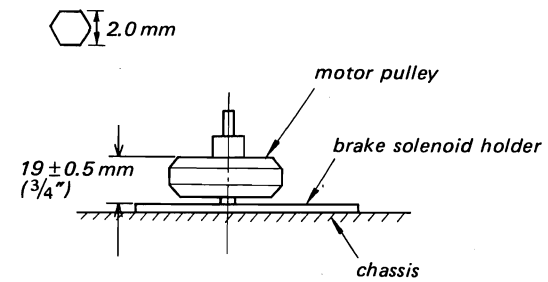

ELECTROSTATIC DISCHARGE BRUSH INSTALLATION

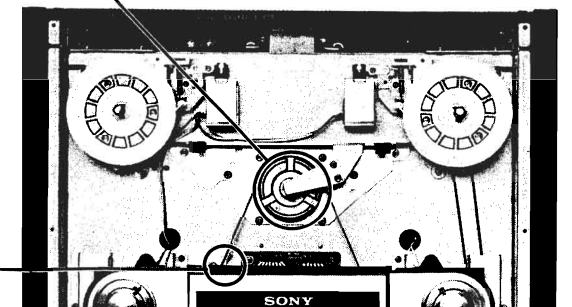
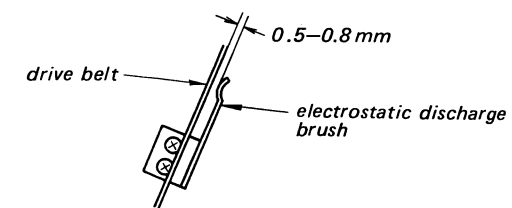

SECTION 3  
ADJUSTMENTS

3-1. MECHANICAL ADJUSTMENTS

Tape Path Adjustment

1. In playback mode, travel a blank tape SLH-S1, and adjust the positions of the tension-arm guide and intermediate pin.

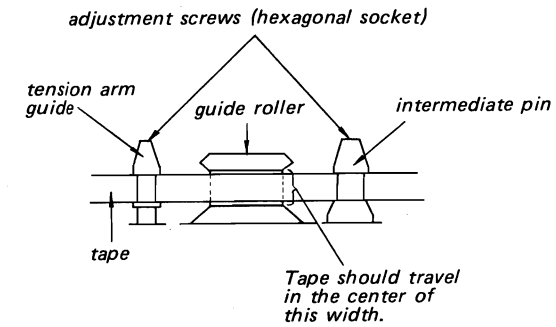

After the adjustment, tighten the adjustment screws.

2. Travel a blank tape SLH7-740 and adjust the position of the tape guides to eliminate tape curls.

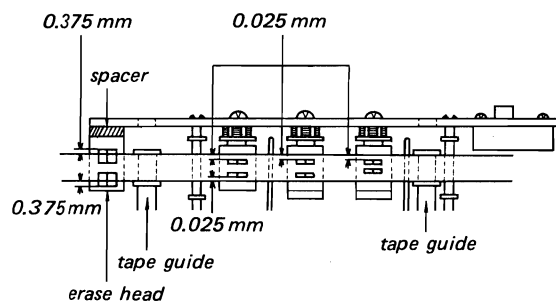

3. Travel a blank tape SLH-S1 and adjust the height of each head for the specified clearances. To adjust the erase head height, select appropriate spacer.

To adjust the record and playback heads, turn the height/zenith adjustment screws in the same angle and direction.

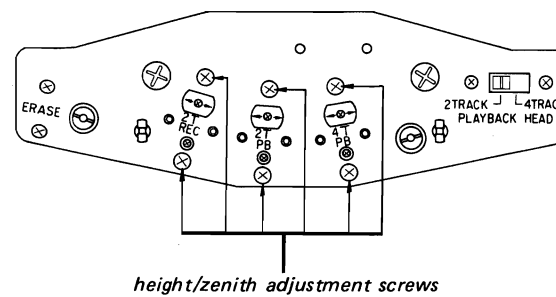

After the adjustment, apply a suitable locking compound to the adjusted screws.

Reel Table Height Adjustment

— playback and rewind modes —

1. Loosen the adjustment screws and adjust the height of the reel tables for the specified height.
2. If the tape touches the reel in playback, fast forward and rewind modes, recheck the tension arms, standard reels and the tape.

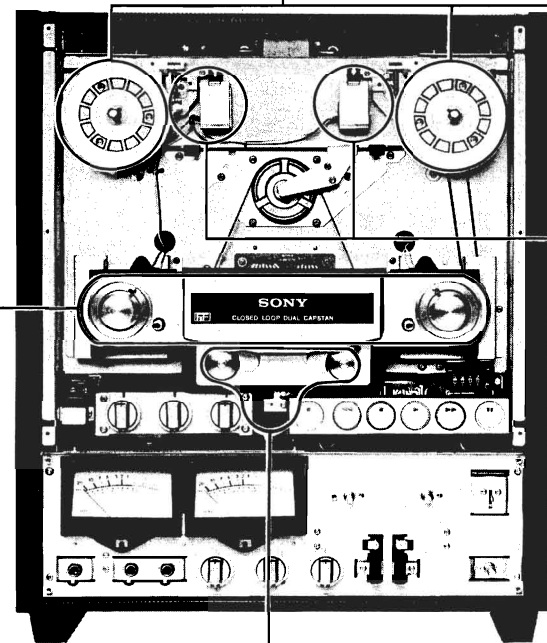
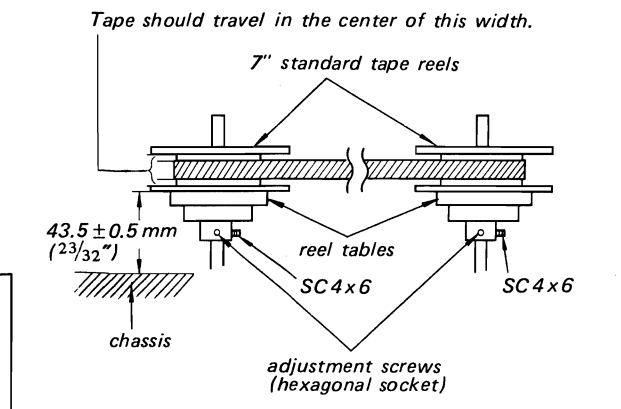

Pinch Roller Lever Position Adjustment

1. Remove the head cover.
2. Reattach both the pinch rollers.
3. Place the set in the playback mode. Check that the solenoid is in on condition (energized).
4. Loosen the adjustment screw and push the slide adjustment plate in the arrowed direction for the specified clearance between the pinch roller levers A and B, and tighten the adjustment screw.
5. After the adjustment, apply a suitable locking compound to the adjustment screw.

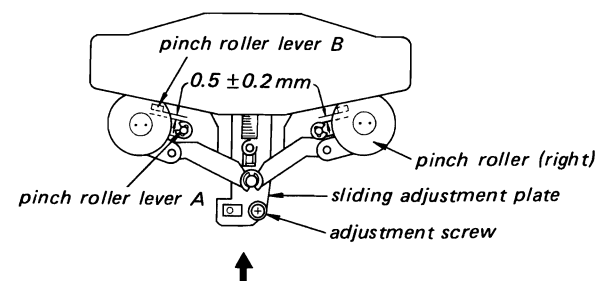

Note: Adjustment screw positions for the 2T PB and 4T PB heads are the same as the 2T REC head. Azimuth adjustment screws are so constructed to react each other. Take care in adjusting azimuth adjustment screw.

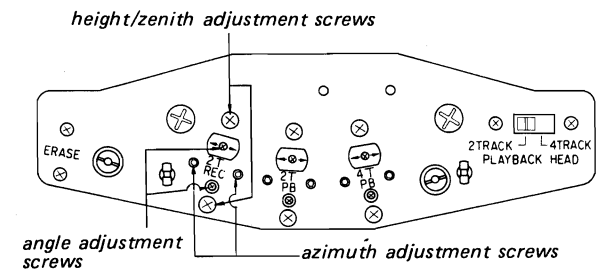

Brake Adjustment (1)

Adjust both the supply- and take-up-side brakes.

1. In stop mode, 0.5–0.7 mm clearance should exist between the brake-band guide and brake band.
2. In playback mode (the brake solenoid should be in ON condition), loosen the adjustment screw and adjust the position of the solenoid link in the arrowed direction so that the brake band and brake-band guide uniformly touch.

Note: If the brake-release stroke is long, the brake band may bend at the position shown with \*. Be sure not to bend the brake band.

3. After the adjustment, apply a suitable locking compound to the adjustment screw.

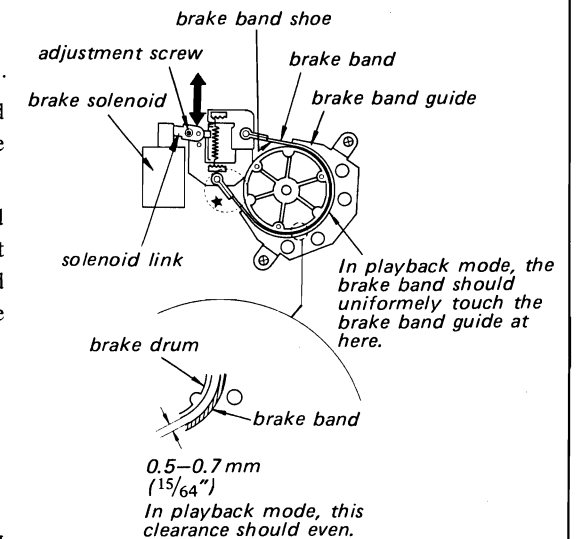

Brake Adjustment (2) and Brake Torque Adjustment

Adjust both the supply- and take-up-side brakes.

1. In stop mode, loosen the adjustment screw and adjust the position of the brake stopper for the specified clearance between the brake stopper and brake lever.
2. After the adjustment, tighten the adjustment screw and apply a suitable locking compound to the screw.
3. Measure both the forward and backward brake torques. Adjust spring-hook position for the specified torques.

backward torque: 1,800–2,500 g-cm  
(25–34 oz-inch)  
forward torque: 600–700 g-cm  
(8.5–9.5 oz-inch)

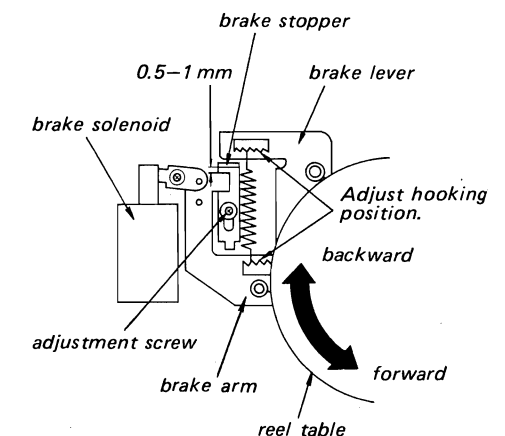

**Pinch Roller Pressure Check**

— playback mode —

1. Place the dial-cord ring between the pinch roller and pinch-roller cap.

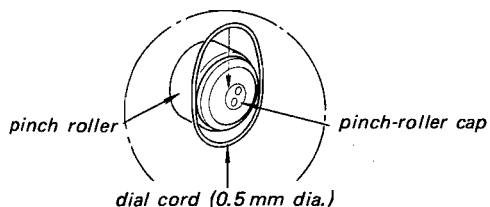

2. In playback mode, pull the spring scale on the center line made by the centers of the capstan and pinch roller.
3. Slowly return the pinch roller and read the spring scale just when the pinch roller starts to rotate.

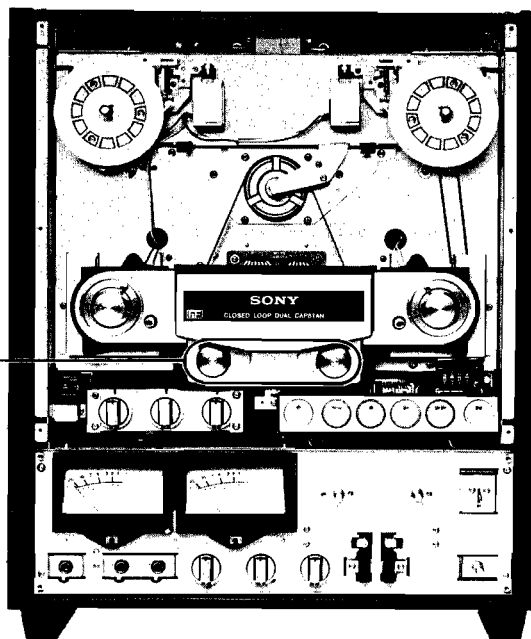
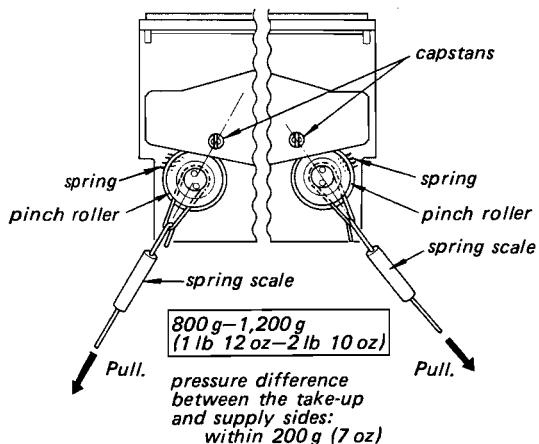

**Forward Torque Adjustment**

1. Remove the side board (right).
2. Apply the rated ac voltage to the AC IN.
3. Set the TAPE SPEED switch to 19 cm/s and REEL SIZE switch to 10½.
4. In playback mode, adjust RV703 for the specified torques.
5. Set REEL SIZE switch to 7 and check torques.

	REEL SIZE switch	
	10½	7
50 Hz	520-580 g-cm (7.3-8.0 oz-inch)	260-320 g-cm (3.7-4.4 oz-inch)
60 Hz	380-440 g-cm (5.8-6.1 oz-inch)	180-240 g-cm (2.5-3.3 oz-inch)

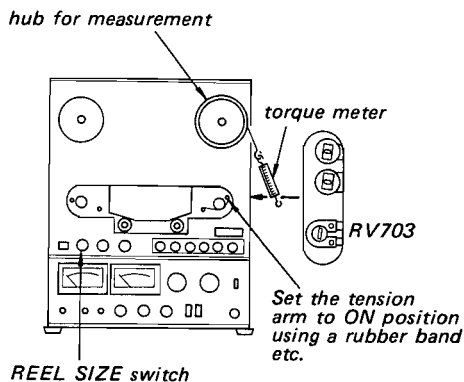

**Supply Reel Back Tension Adjustment**

**Note:** This adjustment requires a ultra-low frequency audio signal generator. If the signal generator is not available, do not attempt this adjustment.

1. Remove the side board (left).
2. Apply the rated ac voltage to AC IN.
3. Set RV702 to the fully-counterclockwise stop.
4. Put a torque meter on the supply reel table.
5. Unsolder the RED and WHT lead wires from the FG at the system control board.
6. Set the signal generator's frequency to 20.2 Hz and attenuator to -20 dB.
7. Connect the signal generator to the points from where the two lead wires are unsoldered in step 5.
8. Set REEL SIZE switch to 10½ and TAPE SPEED switch to 19 cm.
9. In playback mode, adjust RV702 for the specified torque.

	Back tension torque
50 Hz	150 g-cm (2.1 oz-inch)
60 Hz	120 g-cm (1.65 oz-inch)

10. Change the audio signal generator's frequency to 7.14 Hz and check the torque meter reading.

	Torque meter reading
50 Hz	280-340 g-cm (3.9-4.7 oz-inch)
60 Hz	220-280 g-cm (3.1-3.8 oz-inch)

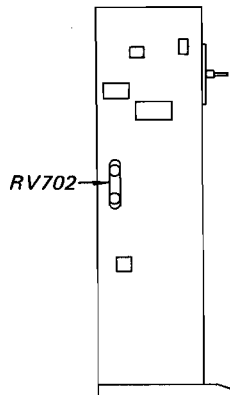

**Fast Forward and Rewind Back Tension Check**

1. Apply the rated ac voltage to AC IN.
2. Turn either the left- or right-side tension arm on using a rubber band.
3. Put a torque meter on the supply reel table. In fast forward mode, pull the torque meter in the arrowed direction at a speed of 19-9.5 cm/s and read the fast forward back tension on the torque meter.
4. Put a torque meter on the take-up reel table. In rewind mode, pull the torque meter and read the rewind back tension as in step 3.

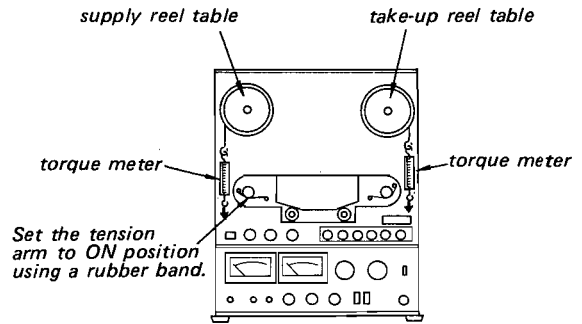

	REEL SIZE switch	
	10½	7
50 Hz	110-150 g-cm (1.6-2.0 oz-inch)	80-120 g-cm (1.15-1.6 oz-inch)
60 Hz	70-110 g-cm (1.0-1.5 oz-inch)	50-90 g-cm (0.7-1.2 oz-inch)

**3-2. SYSTEM CONTROL CHECK**

**System Control Check**

**Setting:**

- REEL SIZE switch: 10½
- TAPE SPEED switch: 19 cm
- TIMER switch: OFF
- MONITOR switch: TAPE
- PB LEVEL control: center click
- REC MONITOR MUTE switch: OFF
- INPUT SELECT switch: LINE  
(AEP, UK model)
- REC MODE switches: released positions

Put the 10½-inch blank tapes on the set.

**Checking:**

1. Turn POWER switch ON. The VU meter lamps should light up.
2. Depress REC MODE switches. The L-side lamp should light up when the L-side REC MODE switch is depressed, and the R-side lamp should light up when the R-side REC MODE switch is depressed. And the record button lamp should put on and off repeatedly.
3. Depress the pause button. The pause button lamp should light up.
4. Depress the record and forward buttons simultaneously. The record button lamp should turn from flickering to ON. At the same time, the forward button lamp should light up.
5. Press the pause button. The pause button lamp should turn off and the pinch roller should press the capstan and become in forward record mode.
6. Depress the fast forward button. The set should become in the fast forward mode. In this mode, the record button lamp flickers, forward button lamp turns off and the fast forward button lamp turns on.
7. Depress the rewind button. The set should become in the rewind mode. In this mode, the fast forward button lamp should turn off and rewind button lamp turns on.
8. Depress the forward button. The rewind button lamp should turn off and forward button lamp turns on. The tape should once completely stop traveling, and then become in the forward mode.
9. The set should become in the stop mode only when both the tension arm microswitches turn off. The set should not become in the stop mode when one of the tension arm microswitches turns off.
10. Turn TIMER switch ON. Turn POWER switch OFF once, and two to three second later turn POWER switch ON. Now the set should become in the forward record mode automatically.
11. With REC MODE switches released (i.e., in the playback positions), perform the same procedure as shown in step 10. The set should become in forward mode automatically.
12. Place the set in the forward record and simultaneous monitoring mode. Turn REC MONITOR MUTE switch on the rear panel ON. Now the signal should not come out from LINE OUT jacks.  
Rewind the recorded portion of the tape and place the set in the forward mode. Now the signal should come out from LINE OUT jacks. Turn REC MONITOR MUTE switch OFF.
13. Depress the forward and pause buttons. Move the recorded portion of the tape back and forth. Sound signal should come out from LINE OUT jacks.

### 3.3. ELECTRICAL ADJUSTMENTS

**Note:** The adjustments should be performed in the order given in this service manual. The adjustments should be performed for both L-CH and R-CH.

#### Standard Record:

Set the REC LEVEL control for the specified output level.

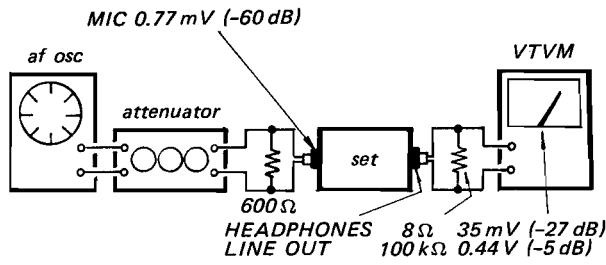

#### Control and Switch Settings:

Unless otherwise specified, set the controls and switches as follows.

Controls	In playback	In record
MIC REC VOL	/	The position to produce the rated LINE OUT level with rated MIC input level.
LINE REC VOL		The position to produce the rated LINE OUT level with rated LINE IN level.
PB VOL	center click	center click

Switch	In playback	In record
POWER	ON	ON
REEL SIZE	7	7
TAPE SPEED	19	19
TIMER	OFF	OFF
MIC ATT	/	0
TAPE SELECT (BIAS)	/	MED
TAPE SELECT (EQ)	/	SPECIAL
REC MODE	PB	REC
MONITOR	TAPE	SOURCE (TAPE)
REC MONITOR MUTE	OFF	OFF
INPUT SELECT (AEP, UK model)	LINE	LINE



**B+ Voltage Adjustment**

Adjustment Location:

– function button board –

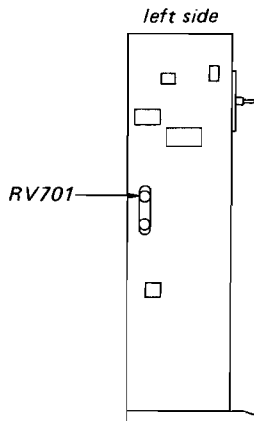
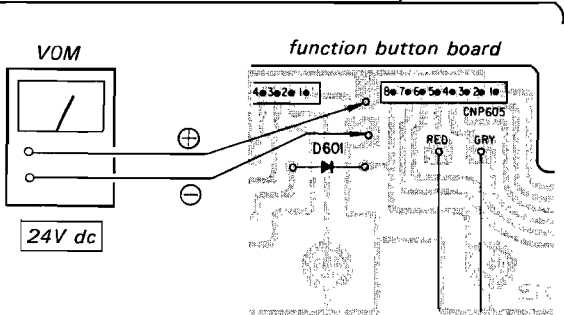
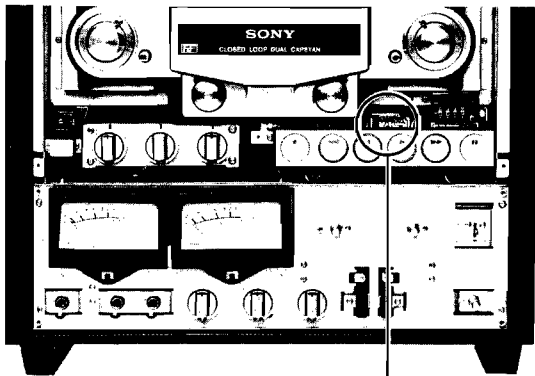

**Tape Speed Adjustment**

Procedure:

Mode: playback

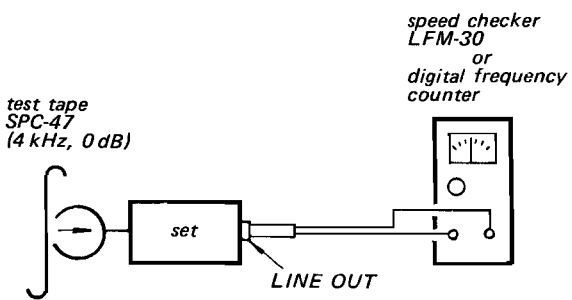

Use a non-metric screwdriver. Adjust RV901 (38 cm/s) and RV902 (19 cm/s) for 0% checker or 8,000 Hz (38 cm/s) and 4,000 Hz (19 cm/s) counter readings.

Specification:

Speed checker	Frequency counter
$\pm 0.75\%$	7,940–8,060 Hz (38 cm/s) 3,970–4,030 Hz (19 cm/s)

Frequency difference between beginning and end of tape:

- 38 cm/s: within 0.5% or 40 Hz
- 19 cm/s: within 0.5% or 20 Hz

Adjustment Location:

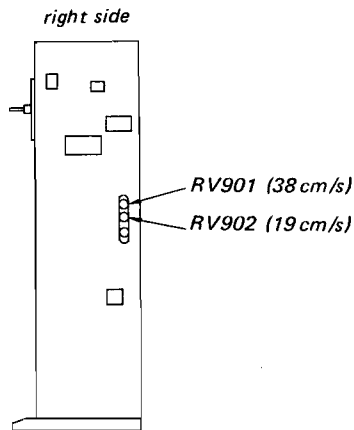

## Playback Head Angle Adjustment

### Procedure:

- Mode: playback  
PLAYBACK HEAD switch: 2 TRACK

SONY J-19-F2  
(4th tone, 12.5 kHz, -10 dB)

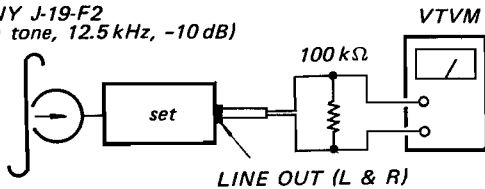

Loosen the adjustment screws ① and ② and adjust the position of the 2T PB head by moving the screw ② in the arrowed direction for the highest VTVM reading. After the adjustment, apply a locking compound to the screws.

- Mode: playback  
PLAYBACK HEAD switch: 4 TRACK  
Adjust the position of the 4T PB head in the same manner.

**Note:** Slightly touch the supply reel and at this time the VTVM reading deviation should be less than 1 dB.

After the adjustment, apply a locking compound to the screws.

### Adjustment Location:

— head base —

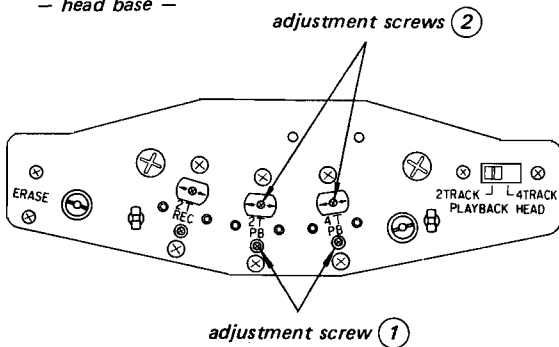

Turn the adjustment screws of the 2T PB head for the highest VTVM reading. If the highest peaks for L and R do not coincide, place the adjustment screw to the point where both L and R outputs are same and within 1 dB from the peaks.

**Note:** The two adjustment screws are so constructed to react each other. When one side screw is loosened, tighten another screw in the same angle.

- Mode: playback

SONY J-19-F2  
(4th tone, 12.5 kHz, -10 dB)

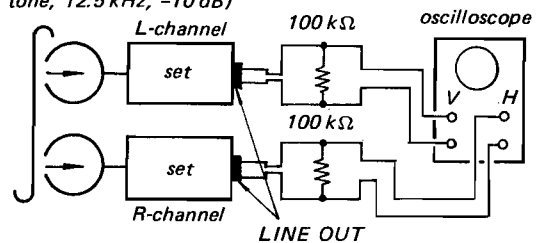

Adjust	On the oscilloscope			
azimuth adjustment screw				
	in-phase	30°	90°	more than 90°
	good			wrong

**Note:** Difference between the highest levels of L and R and the finally adjusted level should be within 1 dB.

- Mode: playback  
PLAYBACK HEAD switch: 4 TRACK  
Perform the same adjustment for the 4T PB head.

### Adjustment Location:

— head base —

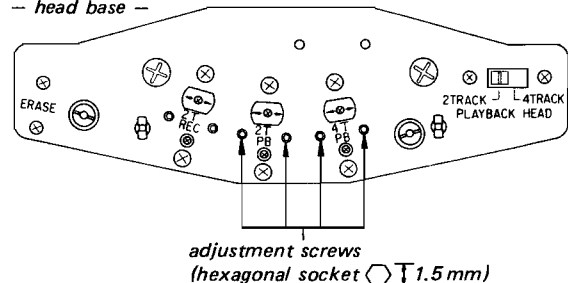

## Playback Head Azimuth and Phase Adjustment

### Procedure:

- Mode: playback  
PLAYBACK HEAD switch: 2 TRACK

SONY J-19-F2  
(4th tone, 12.5 kHz, -10 dB)

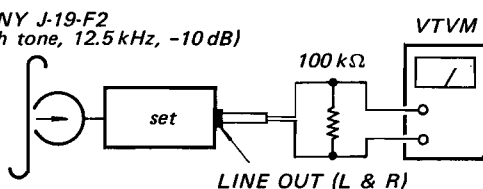

**Playback Frequency Response Adjustment**

**Procedure:**

Mode: playback  
PLAYBACK HEAD switch: 2 TRACK

SONY J-19-F2  
(2nd tone, 400 Hz, -10 dB)  
(3rd tone, 10 kHz, -10 dB)  
(4th tone, 12.5 kHz, -10 dB)

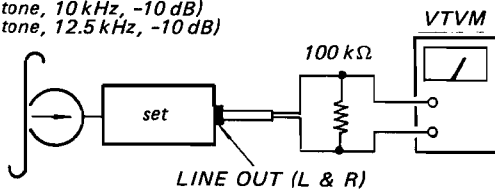

Adjust the pattern connections to obtain the specified values.

Playback	Level difference from 400 Hz
10 kHz	within ± 2 dB
12.5 kHz	

**Adjustment Location:**

— audio amp board —

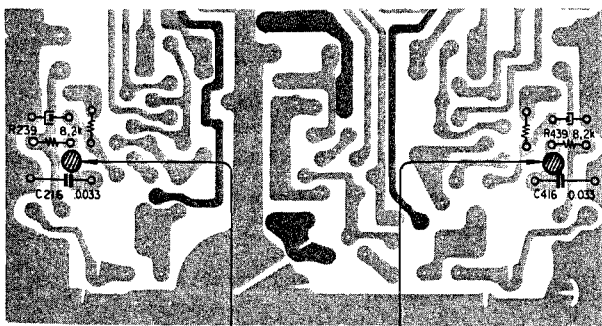

pattern connection      pattern connection

**Note:** After this adjustment perform the playback level adjustment.

**Playback Level Adjustment**

**Procedure:**

Mode: playback  
PLAYBACK HEAD switch: 2 TRACK

SONY J-19-F2  
(1st tone, 400 Hz, 0 dB)

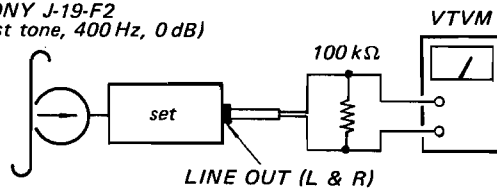

Adjust	VTVM reading
RV104 (L-CH)	0.44 V (-5 dB)
RV304 (R-CH)	allowance: ± 1 dB (0.39–0.49 V)

**Note:** Level difference between L and R channels should be within 1 dB.

2. Mode: playback  
PLAYBACK HEAD switch: 4 TRACK

Check LINE OUT (L & R) levels.

Level difference from 2 TRACK: within 7 dB

Level difference between L and R channels:  
within 4 dB

**Adjustment Location:**

— audio amp board —

RV104 (L-CH)    RV304 (R-CH)

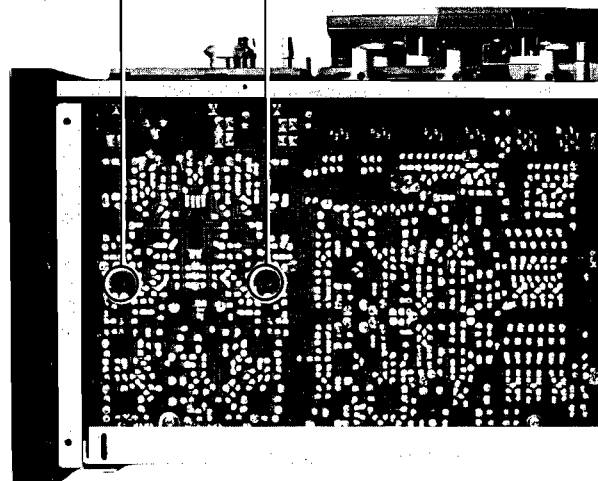

## VU Meter Calibration

### Setting:

MONITOR switch: SOURCE

### Procedure:

1. Mode: record

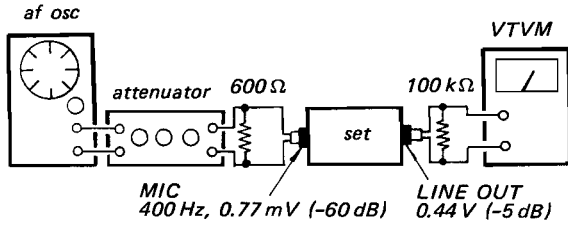

2.
 

Adjust	VU meter indication
RV106 (L-CH)	"0"
RV306 (R-CH)	

### Adjustment Location:

— audio amp board —

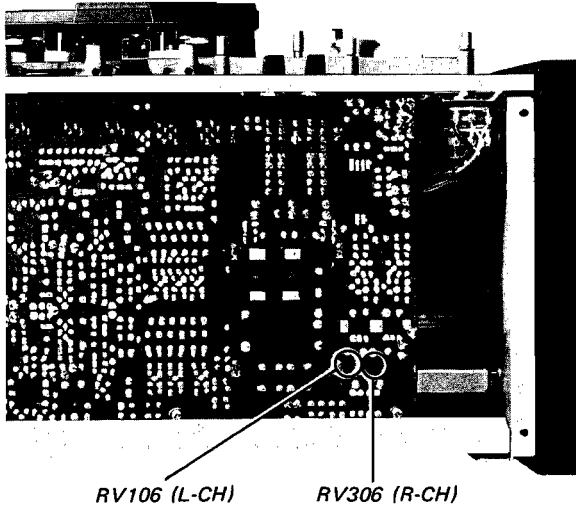

## Record Head Angle Adjustment

### Setting:

MONITOR switch: TAPE

### Procedure:

Mode: record and simultaneous playback

PLAYBACK HEAD switch: 2T REC

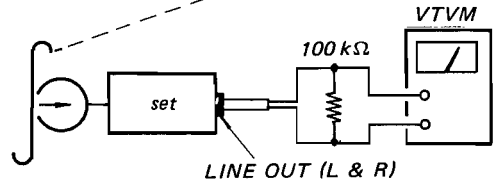
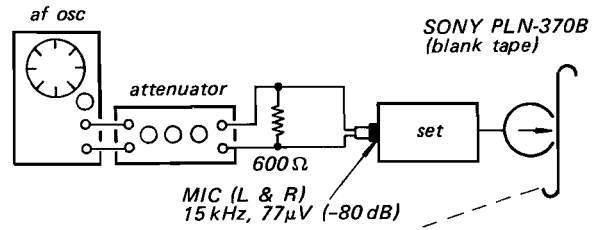

Loosen the adjustment screws ① and ②. Correctly position the record head by moving the adjustment screw ② in the arrowed directions for the highest VTVM reading.

**Note:** Slightly touch the supply reel and at this time the VTVM reading deviation should be less than 1 dB.

After the adjustment, apply a suitable locking compound to the screws.

### Adjustment Location:

— head base —

angle adjustment screw ②

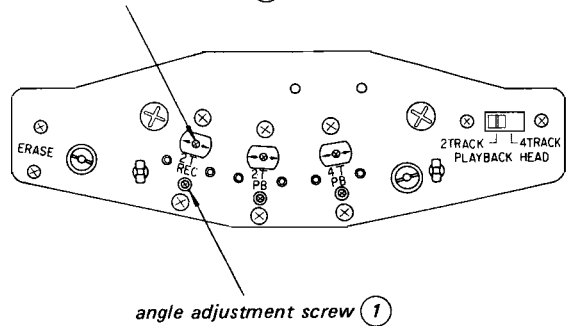

**Record Head Height and Zenith Adjustment**

**Setting:**

MONITOR switch: TAPE

**Procedure:**

Mode: record and simultaneous playback  
PLAYBACK HEAD switch: 2 TRACK

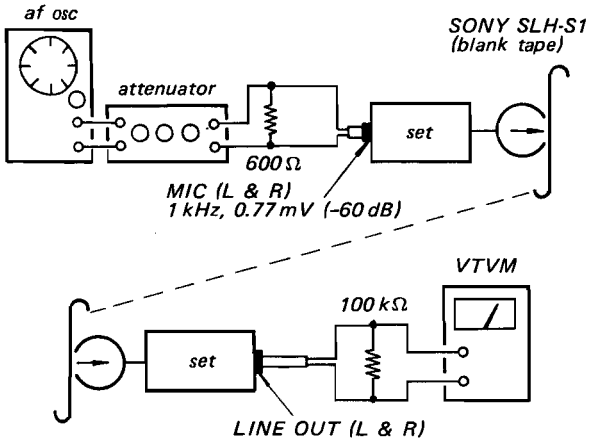

Turn the height and zenith adjustment screws for the highest VTVM reading.

**Adjustment Location:**

- head base -

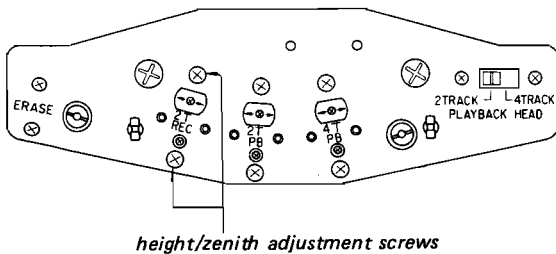

**Record Head Azimuth and Phase Adjustments**

**Setting:**

MONITOR switch: TAPE

**Procedure:**

When a simplified test is made, follow Procedure 1. When an oscilloscope is available, employ Procedure 2.

**Note:** The two adjustment screws are so constructed to react each other. When one side screw is loosened, tighten another screw in the same angle.

1. Mode: record and simultaneous playback

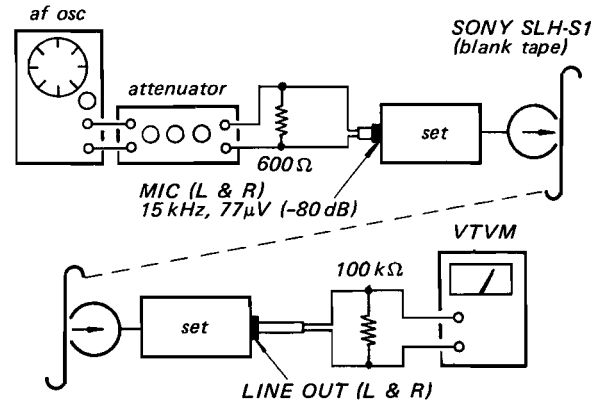

Turn the adjustment screws for the highest VTVM reading. If the highest peaks for L and R do not coincide, place the adjustment screws to the point where both L and R outputs are same and within 1 dB from the peaks.

2. Mode: record and simultaneous playback

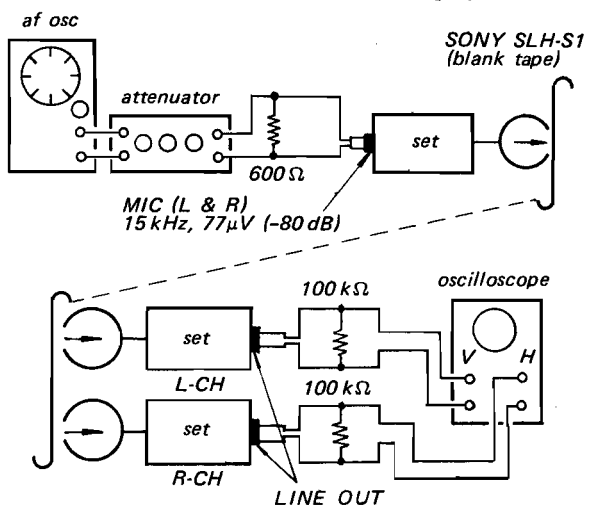

Adjust	On the oscilloscope			
azimuth adjustment screw				
	in-phase	30°	90°	more than 90°
	good			wrong

**Note:** Difference between the highest levels of L and R and the finally adjusted level should be within 1 dB.

**Adjustment Location:**

- head base -

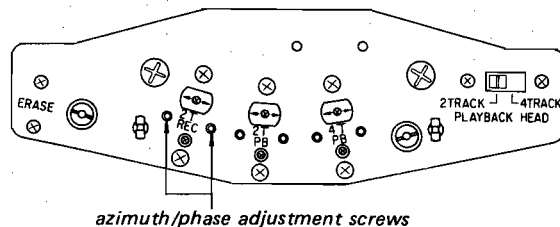

## Record Bias Adjustment

### Setting:

MONITOR switch: TAPE

### Procedure:

Mode: record and simultaneous playback

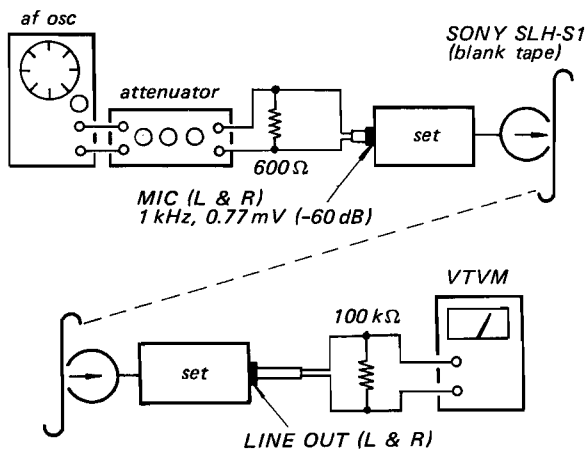

As trimmer capacitor C135 (L-CH) or C335 (R-CH) is slowly turned clockwise, VTVM reading will go up to a maximum and then start falling again. Adjust the capacitor until VTVM reads 0.5 dB below and beyond the maximum reading.

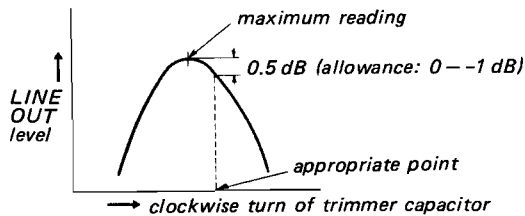

### Adjustment Location:

— audio amp board —

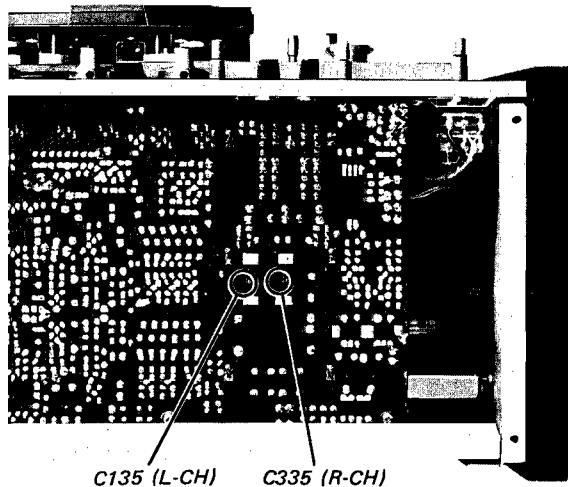

## Record Level Adjustment

### Setting:

MONITOR switch: TAPE

### Procedure:

Mode: record and simultaneous playback

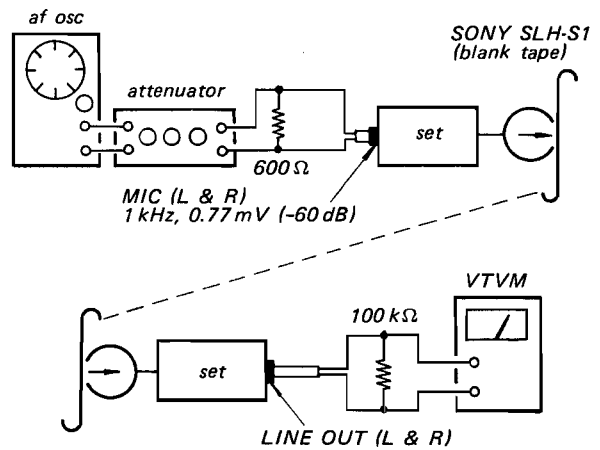

Adjust	VTVM reading
RV103 (L-CH)	0.44 V (-5 dB)
RV303 (R-CH)	

### Adjustment Location:

— audio amp board —

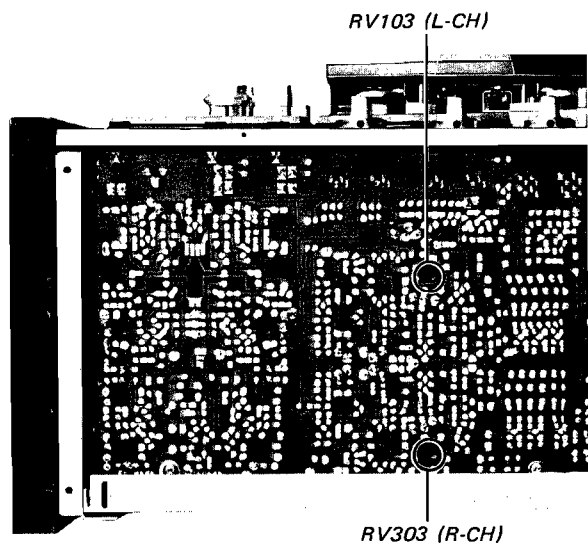

**Record Equalizer Adjustment**

**Setting:**

MONITOR switch: TAPE

**Procedure:**

Mode: record and simultaneous playback

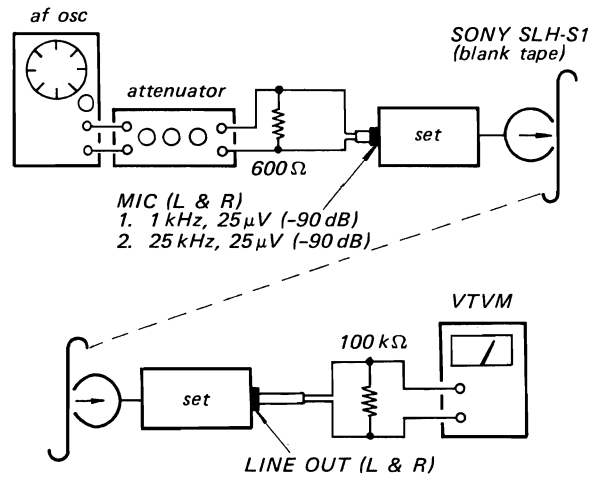

	Adjust	Remarks
1 kHz	L102 (L-CH) and L302 (R-CH)	Same LINE OUT level at both frequencies.
25 kHz	L302 (R-CH)	

Level-difference allowance of 25 kHz signal from 1 kHz: 0 dB - -3 dB.

**Adjustment Location:**

- audio amp board -

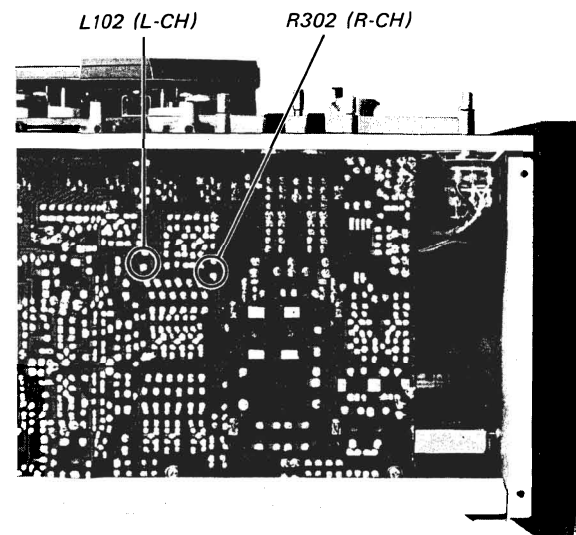

**Record Bias Trap Adjustment**

**Setting:**

MIC REC control: 0  
 LINE REC control: 0

**Procedure:**

Mode: record

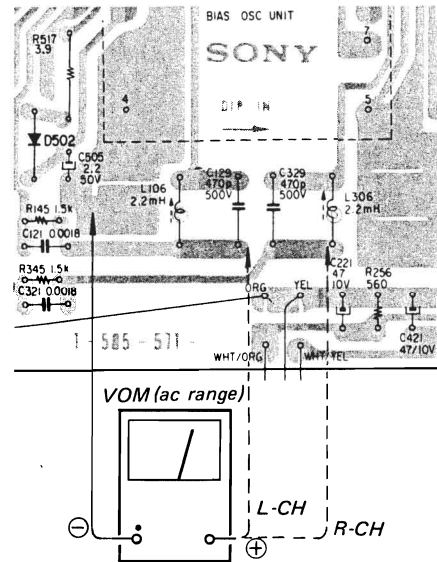

Adjust	VTVM reading
L106 (L-CH) L306 (R-CH)	minimum

**Adjustment Location:**

- audio amp board -

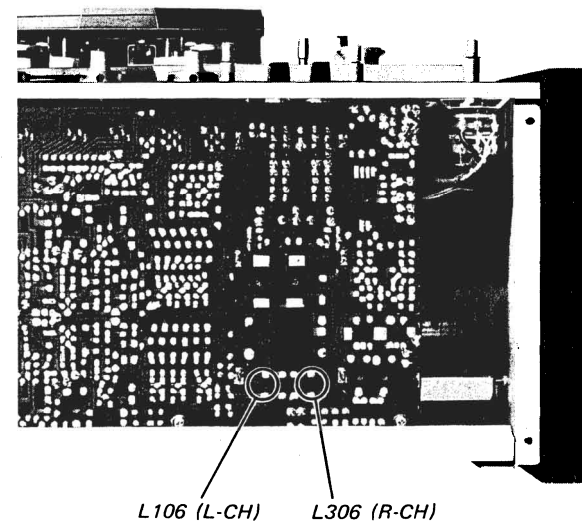

**Dummy Coil Adjustment**

**Setting:**

MONITOR switch: TAPE

**Procedure:**

Mode: record and simultaneous playback

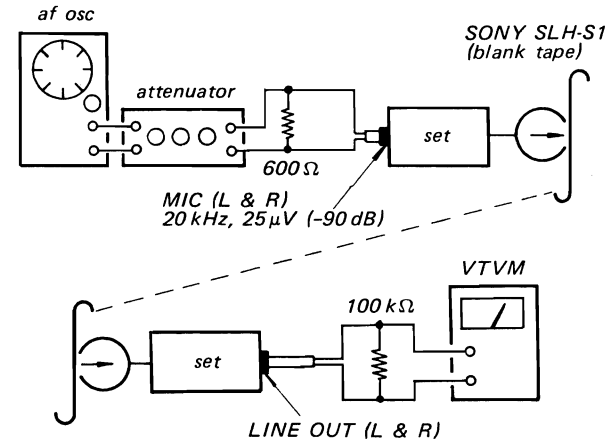

Step	Mode	Adjust	Remarks
1	stereo record and simultaneous playback	-	Record VTVM reading.
2	L channel record and simultaneous playback	L307	same VTVM reading as in step 1.
3	R channel record and simultaneous playback	L107	

**Adjustment Location:**

- audio amp board -

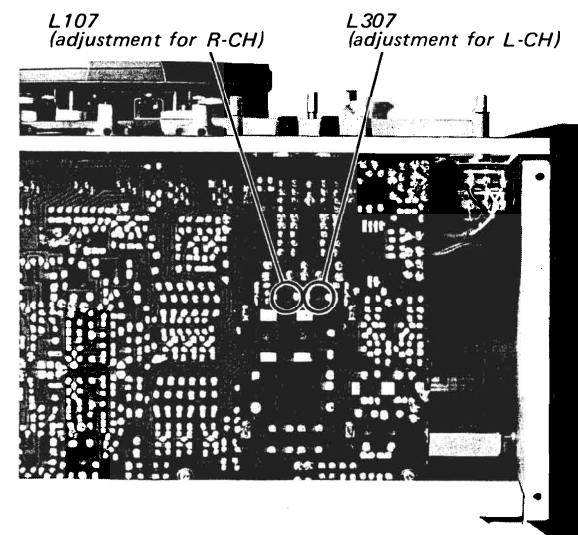

**Dummy Coil Adjustment**

Setting:

MONITOR switch: TAPE

Procedure:

Mode: record and simultaneous playback

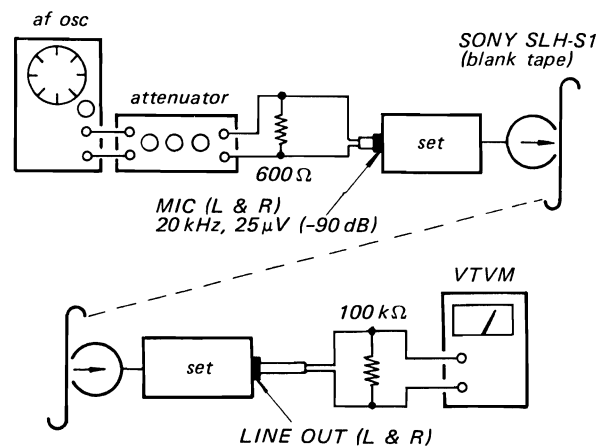

Step	Mode	Adjust	Remarks
1	stereo record and simultaneous playback	-	Record VTVM reading.
2	L channel record and simultaneous playback	L307	same VTVM reading as in step 1.
3	R channel record and simultaneous playback	L107	

Adjustment Location:

- audio amp board -

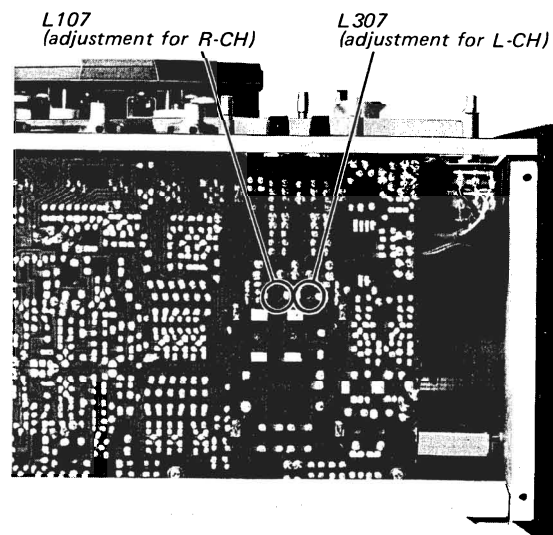

**MEMO**

A series of horizontal dotted lines provided for taking notes.



SECTION 4  
DIAGRAMS

4-1. MOUNTING DIAGRAM

- Amplifier Section (US, Canadian model) -
- Conductor Side -

Replacement Semiconductors  
For replacement, use semiconductors except in ( ).

- Q101, 103, 104  
Q115, 121, 122  
Q301, 303, 304  
Q315, 321, 322  
Q102, 302: 2SC1345-E (2SC458D)    Q504: 2SC1173
- Q105, 108, 109  
Q123, 124  
Q305, 308, 309  
Q323, 324  
Q125, 325: 2SC1475 (2SC1318)    Q505: 2SC1475-13 (2SC1475)
- Q106, 107  
Q110-114, 120  
Q306, 307  
Q310-314, 320  
Q502, 503, 507: 2SC634A (2SC1363)    D101, 102  
D301, 302  
D502, 503  
D103  
D303: 1S1555 (1T40)
- Q116, 316: 2SK43-13 (2SK43)    D501: EQB01-11Z (EQA01-11S)
- Q117, 317: 2SA705
- Q501: 2SK30A
- (After replacing Q505, perform the record bias adjustment on page 22.)

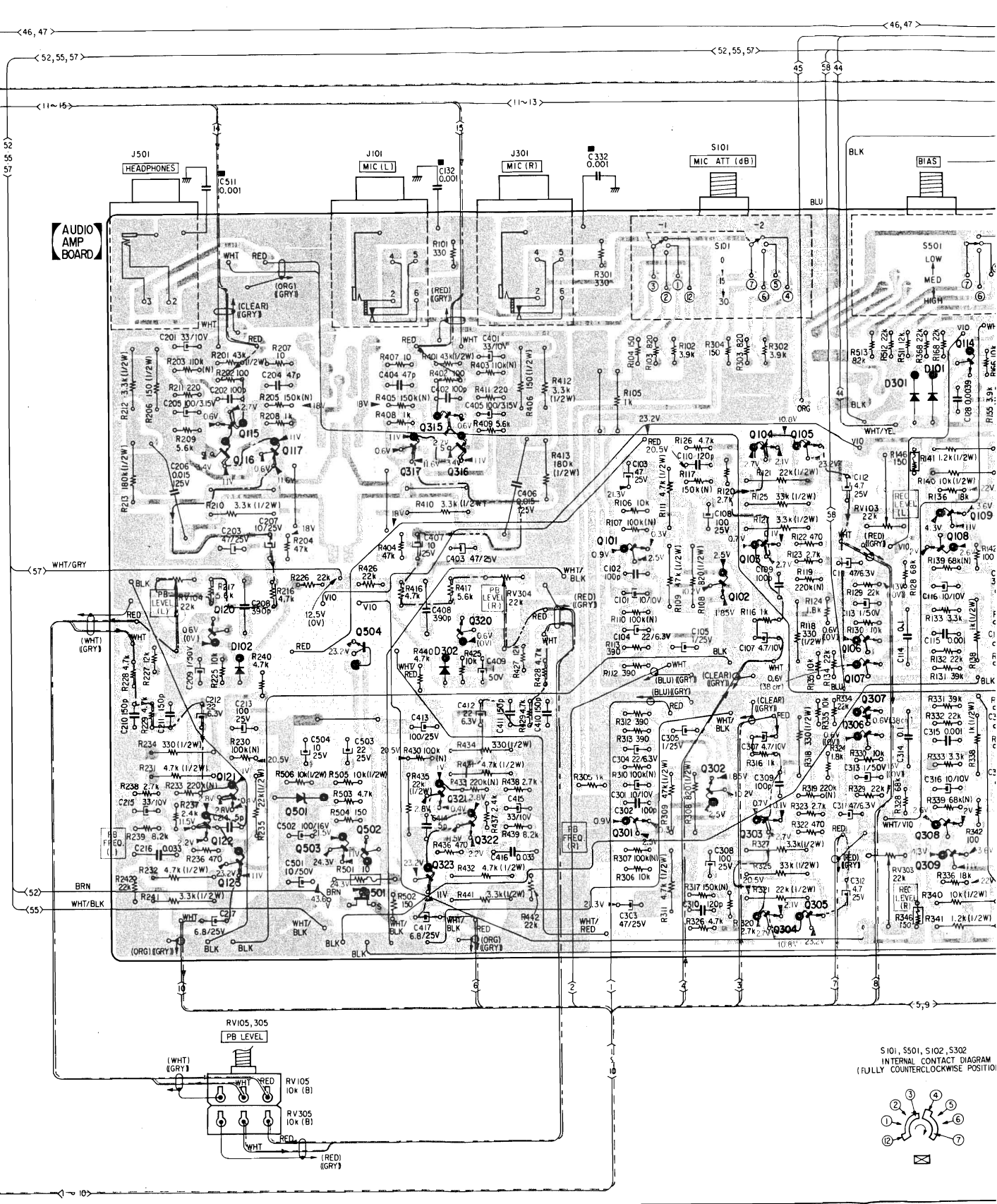
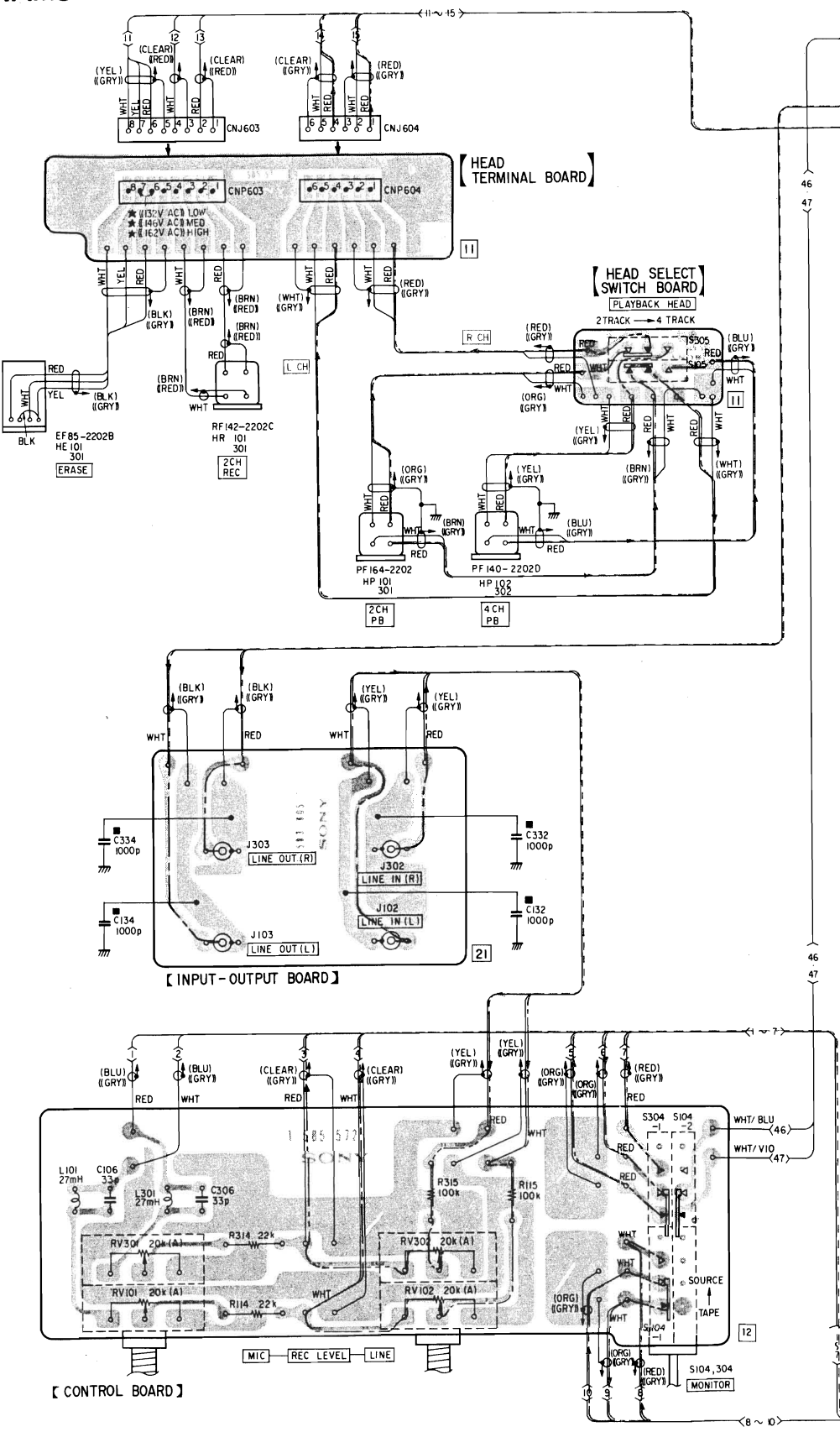

- Note:
- : part mounted on the conductor side.
  - : B+ pattern.
  - : signal path (both channel)
  - : L-CH
  - : R-CH
  - DC resistance measurements are with coils connected on the circuit board, and are approximate.
  - Color code of sleeving over the end of the jacket.

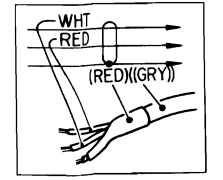

- Readings are taken under no signal conditions and in stop mode with a VOM (20 kΩ/V).
- ( ) : record mode.
- ( ) : forward mode.
- ( ) : S607 is ON.

Q	115	117	504	317	315	101	102	104	105	106	109	114
	120	121	503	323	316			103		107		
	122	123	501	321	322	301	302	303	305	307	308	309
D		102	501		302						301	101

# TC-766-2 TC-766-2

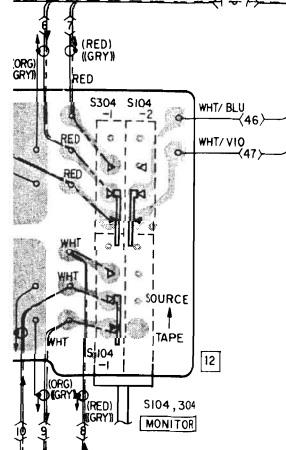
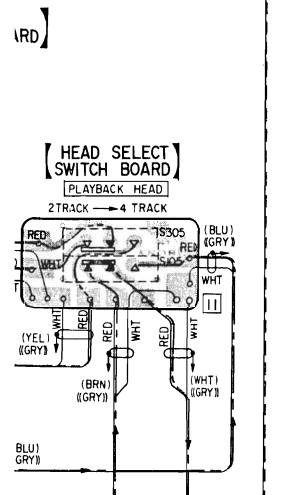
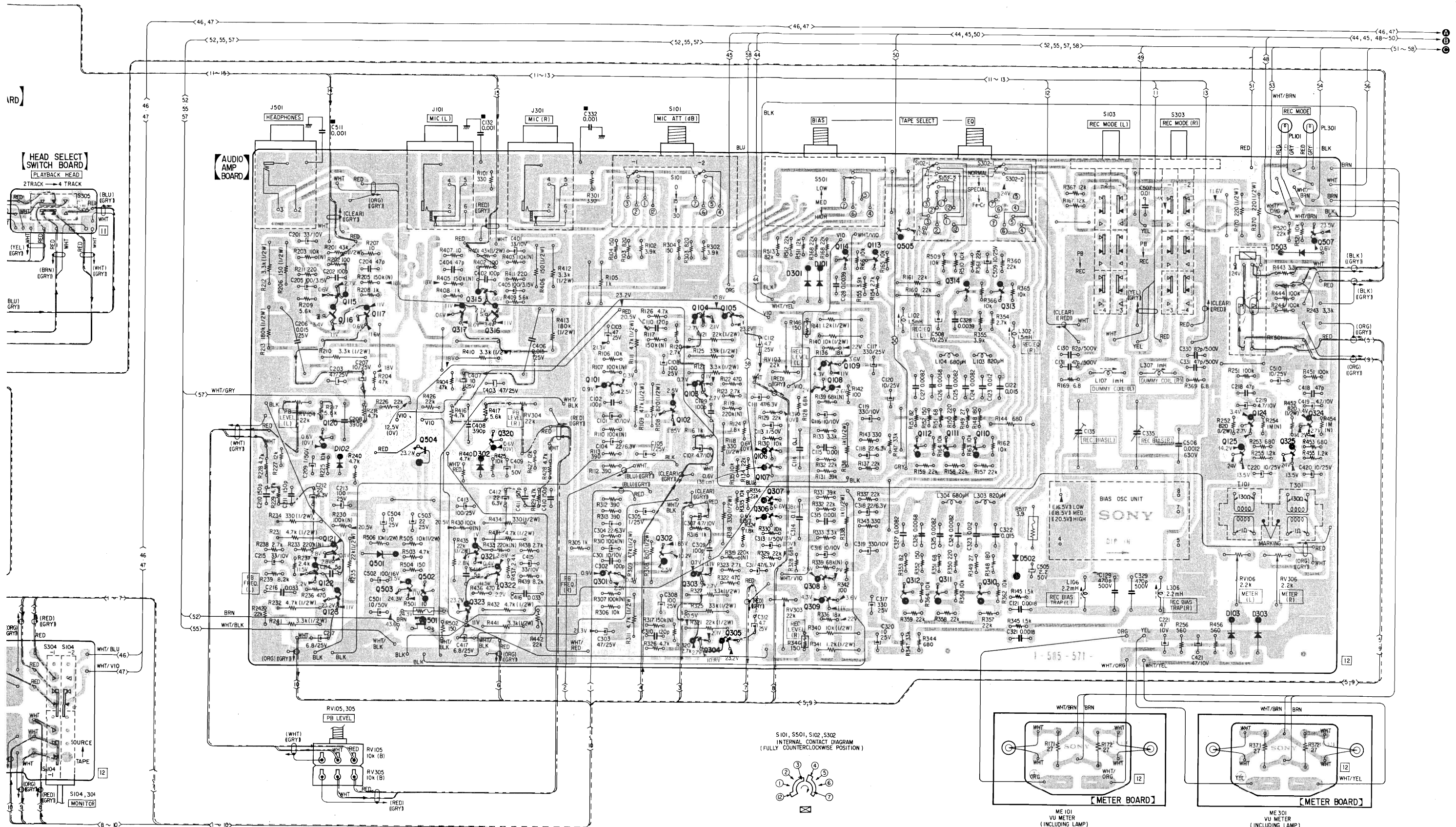

S101, S501, S102, S302  
INTERNAL CONTACT DIAGRAM  
(FULLY COUNTERCLOCKWISE POSITION)

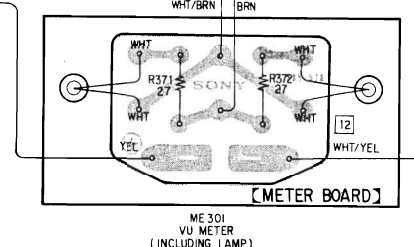
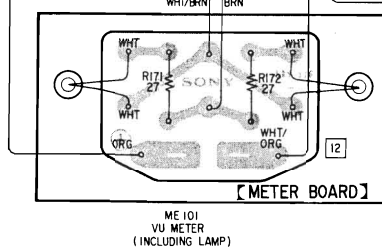
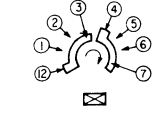

Q	115	117	504	317	315	101	102	104	105	106	109	114	113	505	314	313	124	507
	120	121	503	321	320	301	302	303	305	307	308	309	312	311	310		125	325
D		102	501		302					301	101					502	103	303
																		503

4-2. SCHEMATIC DIAGRAM — Amplifier Section (US, Canadian model) —

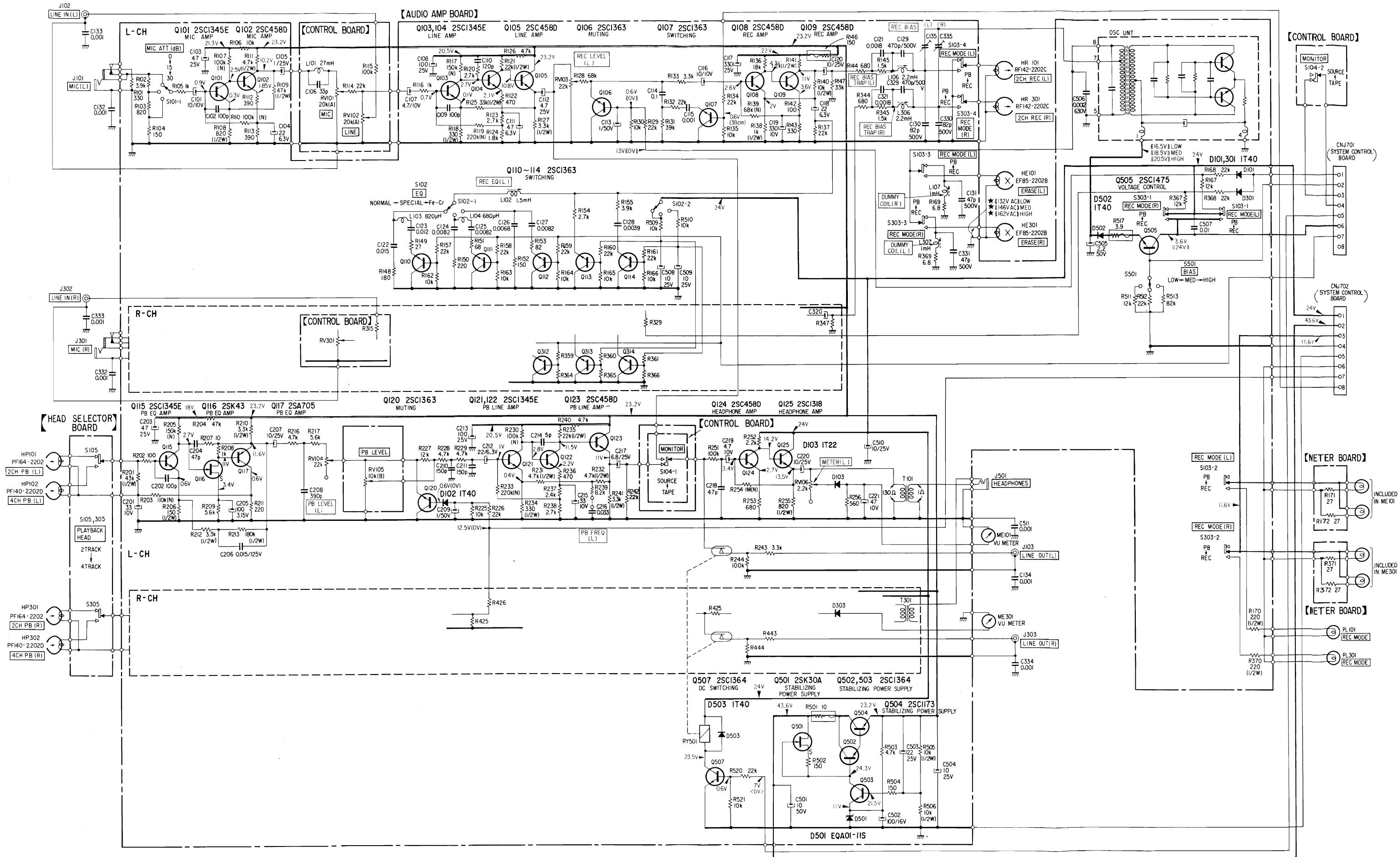



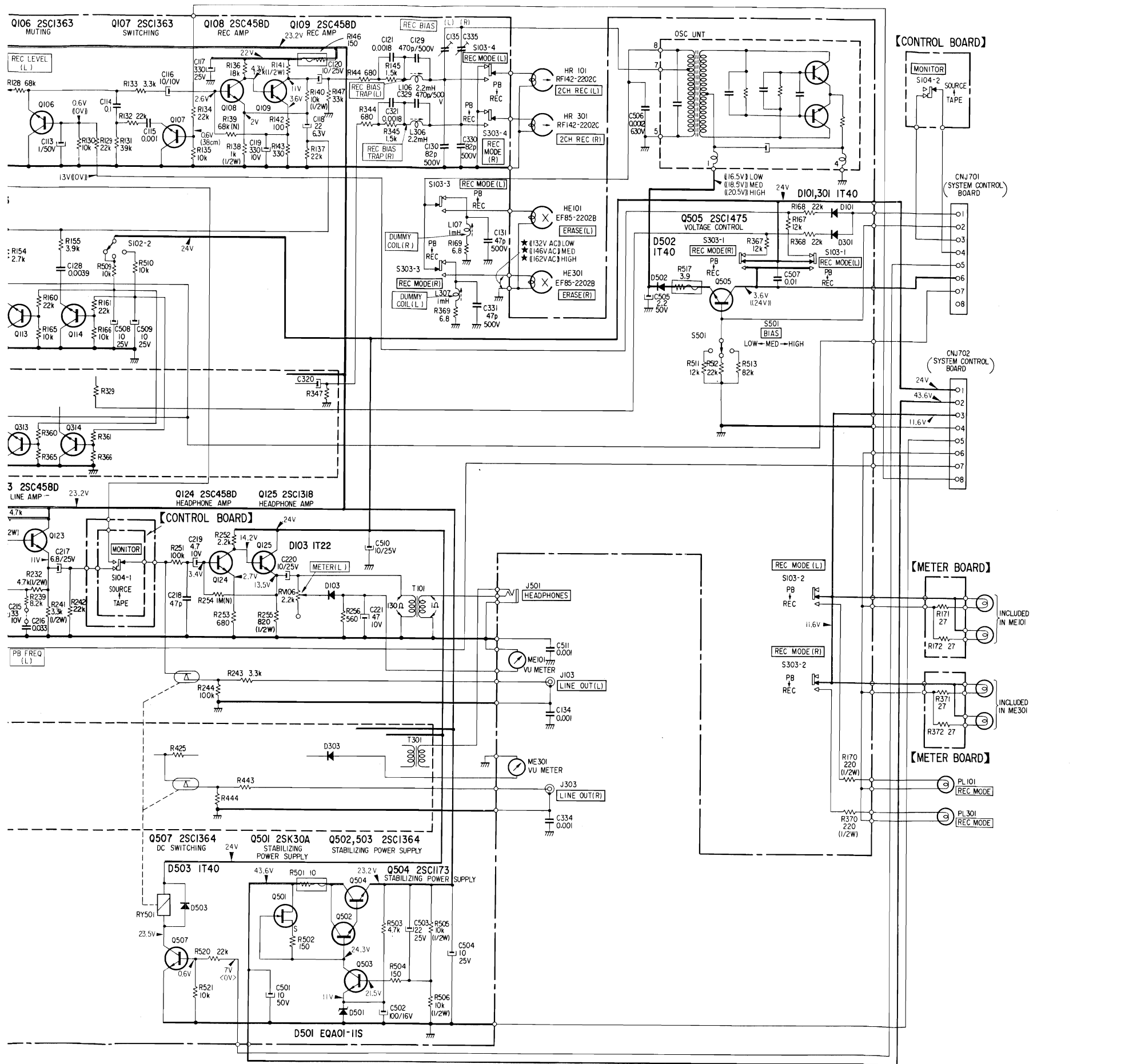

- Note:**
- Components for right channel have the same values as for left channel. Reference numbers are coded from 301 (REC AMP or PB AMP) or 401 (PB AMP).
  - All capacitors are in  $\mu\text{F}$  unless otherwise noted.  $\text{pF} = \mu\mu\text{F}$ . 50WV or less are not indicated except for electrolytics.
  - All resistors are in ohms,  $\frac{1}{4}\text{W}$  unless otherwise noted.  $\text{k}\Omega = 1000\Omega$ ,  $\text{M}\Omega = 1000\text{k}\Omega$ .
  - All variable and adjustable resistors have characteristic curve B, unless otherwise noted.
  - $\text{---/---}$ : fusible resistor.
  - (N): low-noise capacitor and resistor.
  - $\text{---}$ : B+ bus.
  - $\square$ : panel designation.
  - $\square$ : adjustment for repair.
  - $\text{---}$ : chassis ground.
  - Voltages are dc with respect to ground unless otherwise noted.
  - Readings are taken under no signal conditions and in stop mode with a VOM (20  $\text{k}\Omega/\text{V}$ ).
  - (( )): record mode.
  - ( ): forward mode.
  - < >: S607 is ON.
  - AC voltage readings indicated by \* in the bias oscillator circuit are taken with a VTVM.
  - Voltage variations may be noted due to normal production tolerances.
  - Switch

Ref. No.	Switch	Position
S101,301	MIC ATT	0 (dB)
S102,302	EQ	NORMAL
S103,303	REC MODE	PB
S104,304	MONITOR	TAPE
S105,305	PLAYBACK HEAD	2 TRACK
S501	BIAS	MED

4-3. MOUNTING DIAGRAM
- Amplifier Section (UK, AEP model) -
- Conductor Side -

Replacement Semiconductors
For replacement, use semiconductors except in ( ).

- Q101, 103, 104 : 2SC1345-E
Q115, 121, 122 : 2SC1345-E
Q301, 303, 304 : 2SC1345-E
Q126, 326 : 2SC1345-E (2SC458D)
Q501: 2SK30A
Q504: 2SC1173
Q125, 325: 2SC1475 (2SC1318)
Q505: 2SC1475-13 (2SC1475)
Q107, 109, 124, 308, 309, 324 : 2SC634A (2SC458D)
Q108, 109, 124, 308, 309, 324 : 2SC634A (2SC458D)
Q107, 114, 120, 307, 314, 320, 503, 507 : 2SC634A (2SC1363)
Q107, 114, 120, 307, 314, 320, 503, 507 : 2SC634A (2SC1364)
Q116, 316: 2SK43-13 (2SK43)
Q117, 317: 2SA705
Q127, 327: 2SA678 (2SA677)
D101, 102 : 1S1555 (1T40)
D502, 503 : 1S1555 (1T40)
D103 : 1T22A (1T22)
D501: EQB01-11Z (EQA01-11S)

- Note:
- ■ : part mounted on the conductor side.
- B+ : B+ pattern.
- -> : signal path (both channel)
- -> : L-CH
- -> : R-CH
- DC resistance measurements are with coils connected on the circuit board, and are approximate.
- Color code of sleeving over the end of the jacket.

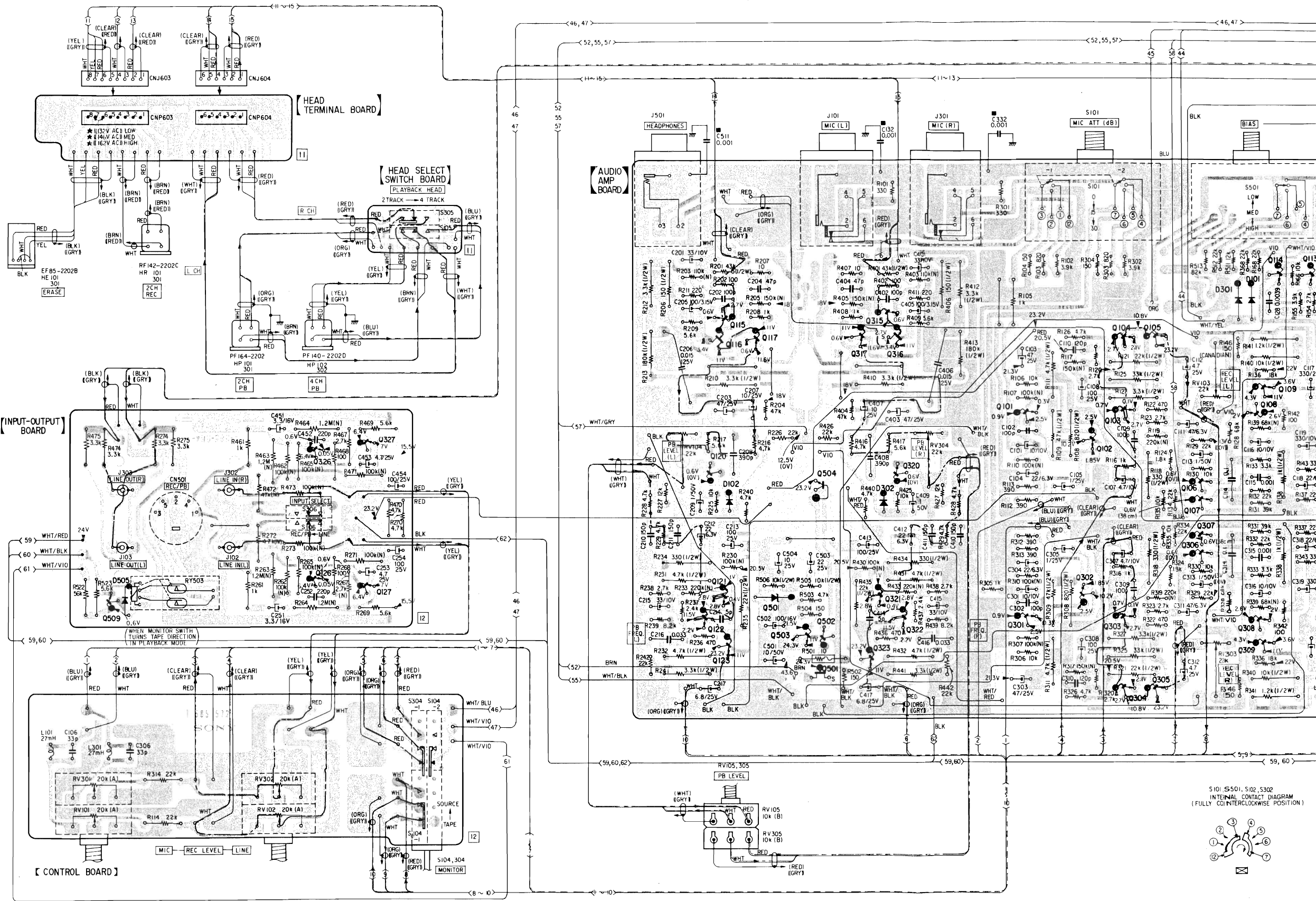
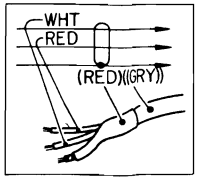

Readings are taken under no signal conditions and in stop mode with a VOM (20 kΩ/V).
( ) : record mode.
( ) : forward mode.
( ) : S607 is ON.

Table with 10 columns and 2 rows of component reference designations and their corresponding locations on the board.

# TC-766-2 TC-766-2

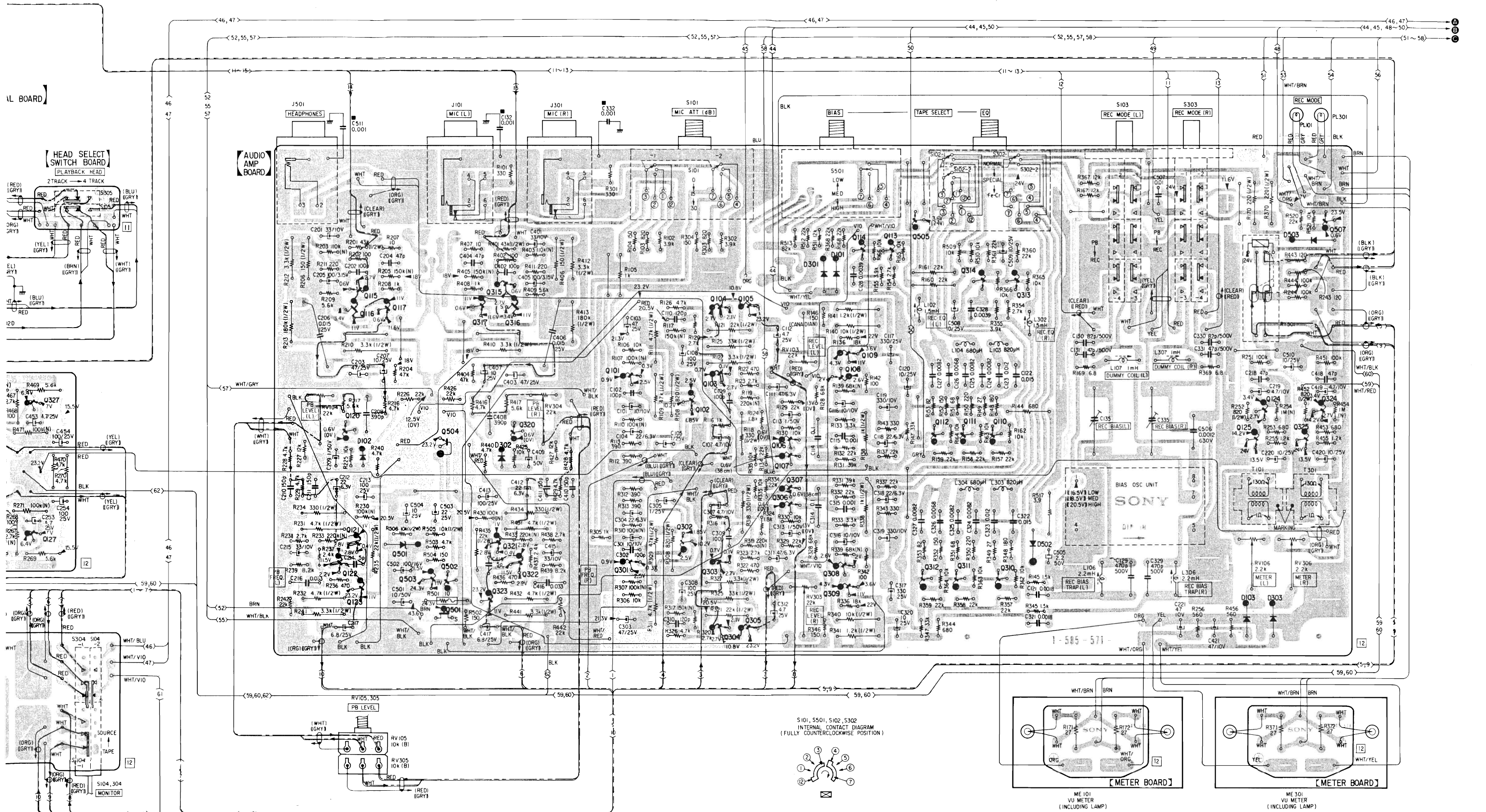

327	115	117	504	317	315	101	102	104	105	106	109	114	113	505	112	111	314	313	124	507	
127	120	116	503	502	316	301	302	303	305	107	108	110	312	311	310				125	325	324
	122	123	501	323	320			304		306	309								103	303	503
			501	302						301	101				502						



# TC-766-2 TC-766-2

## SCHEMATIC DIAGRAM — Amplifier Section (UK, AEP model) —

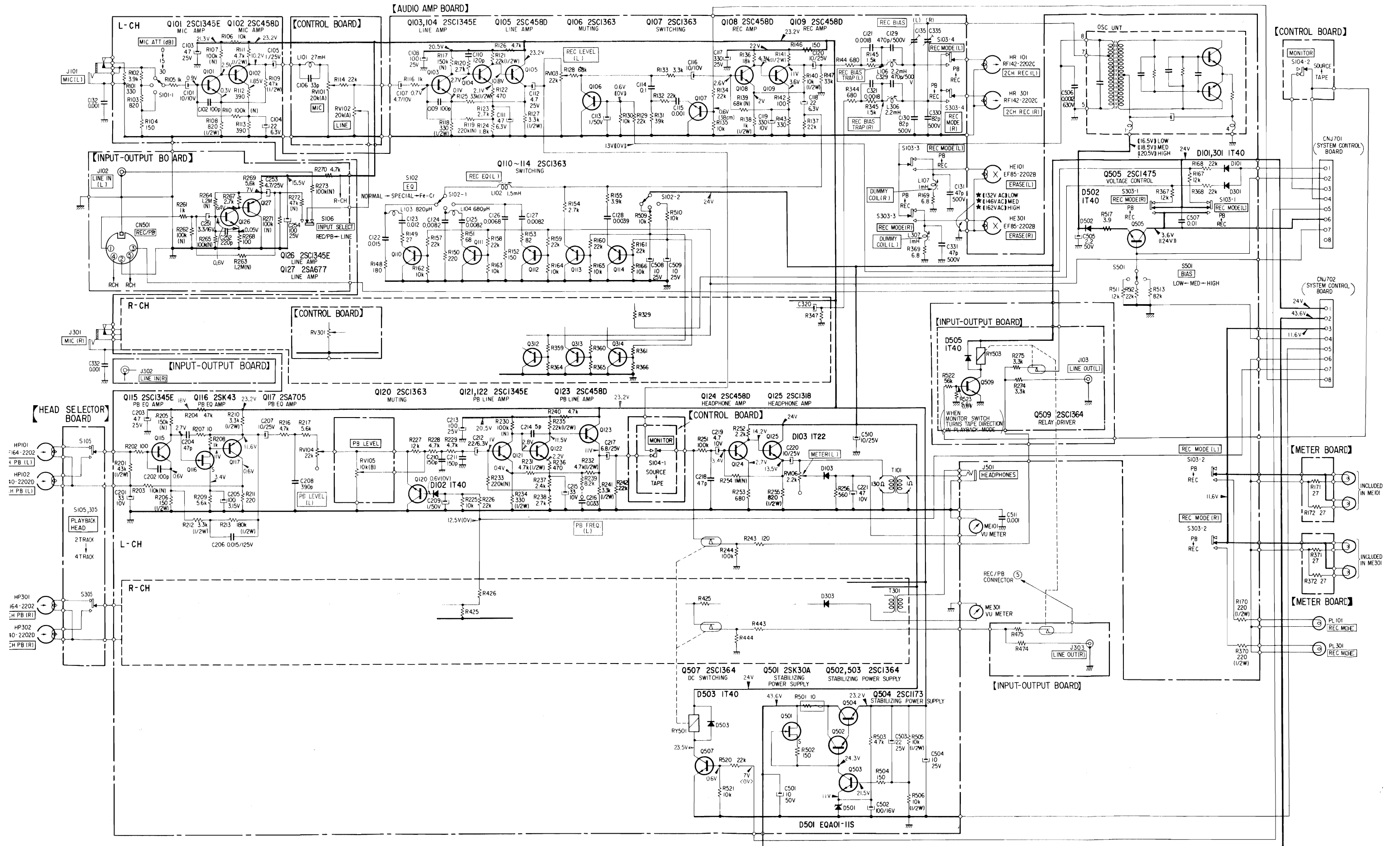

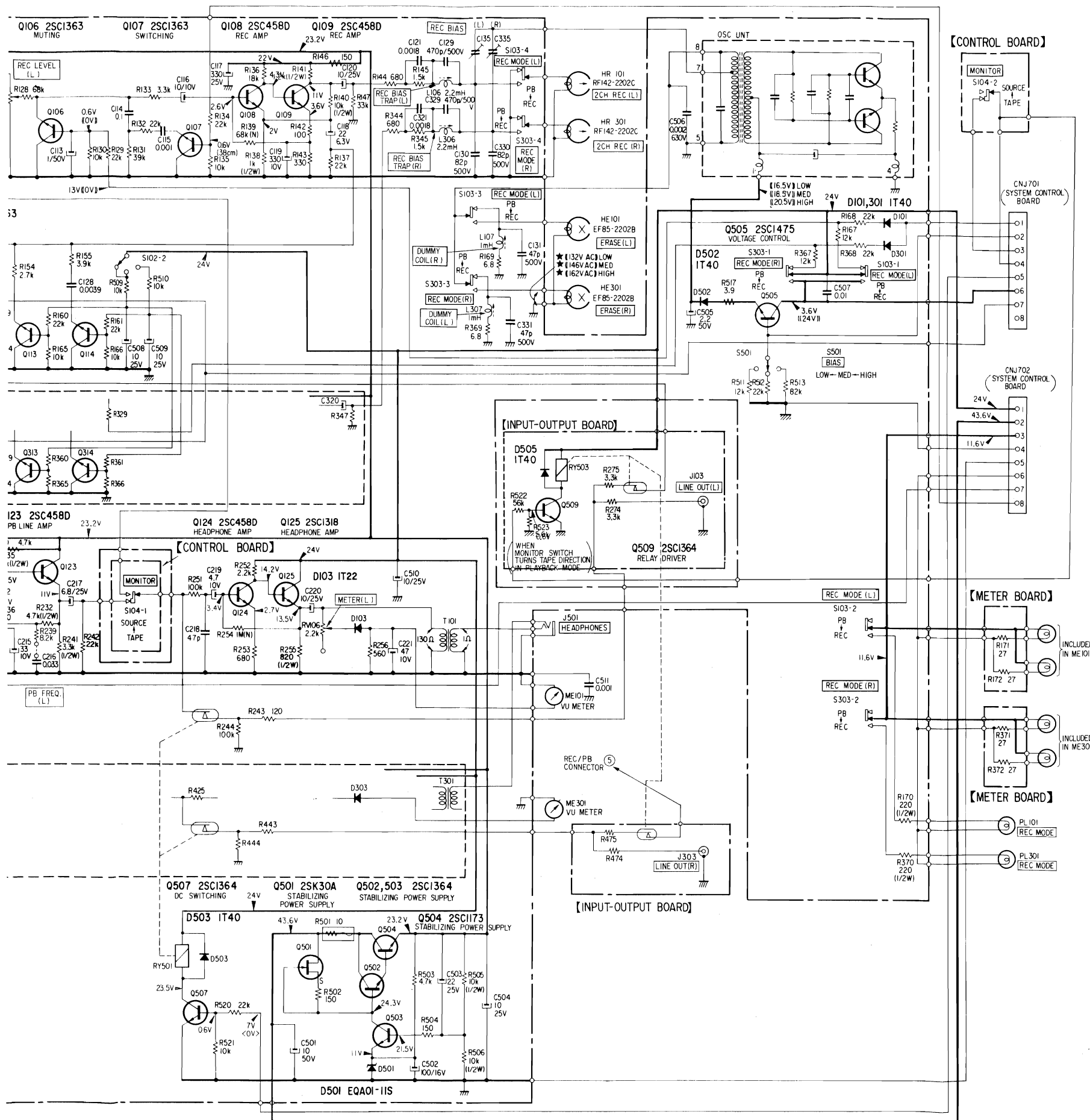

- Note:**
- Components for right channel have the same values as for left channel. Reference numbers are coded from 301 (REC AMP or PB AMP) or 401 (PB AMP).
  - All capacitors are in  $\mu\text{F}$  unless otherwise noted.  $\text{pF} = \mu\mu\text{F}$ . 50WV or less are not indicated except for electrolytics.
  - All resistors are in ohms,  $\frac{1}{2}\text{W}$  unless otherwise noted.  $\text{k}\Omega = 1000\Omega$ ,  $\text{M}\Omega = 1000\text{k}\Omega$ .
  - All variable and adjustable resistors have characteristic curve B, unless otherwise noted.
  - (N) : low-noise capacitor and resistor.
  - $\text{---}$  : B+ bus.
  - $\square$  : panel designation.
  - $\square$  : adjustment for repair.
  - $\text{---}$  : chassis ground.
  - Voltages are dc with respect to ground unless otherwise noted.
  - Readings are taken under no signal conditions and in stop mode with a VOM (20  $\text{k}\Omega/\text{V}$ ).  
 (( )) : record mode.  
 ( ) : forward mode.  
 < > : S607 is ON.
  - AC voltage readings indicated by \* in the bias oscillator circuit are taken with a VTVM.
  - Voltage variations may be noted due to normal production tolerances.
  - Switch

Ref. No.	Switch	Position
S101,301	MIC ATT	0 (dB)
S102,302	EQ	NORMAL
S103,303	REC MODE	PB
S104,304	MONITOR	TAPE
S105,305	PLAYBACK HEAD	2 TRACK
S106,306	INPUT SELECT	LINE
S501	BIAS	MED



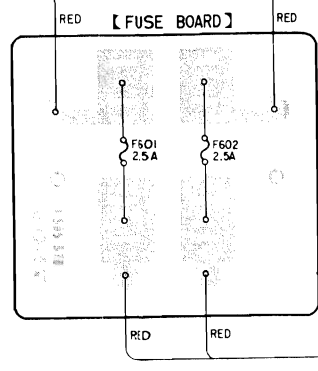
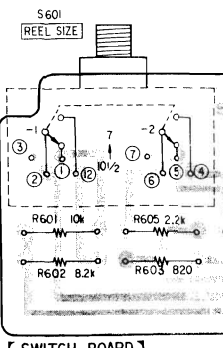
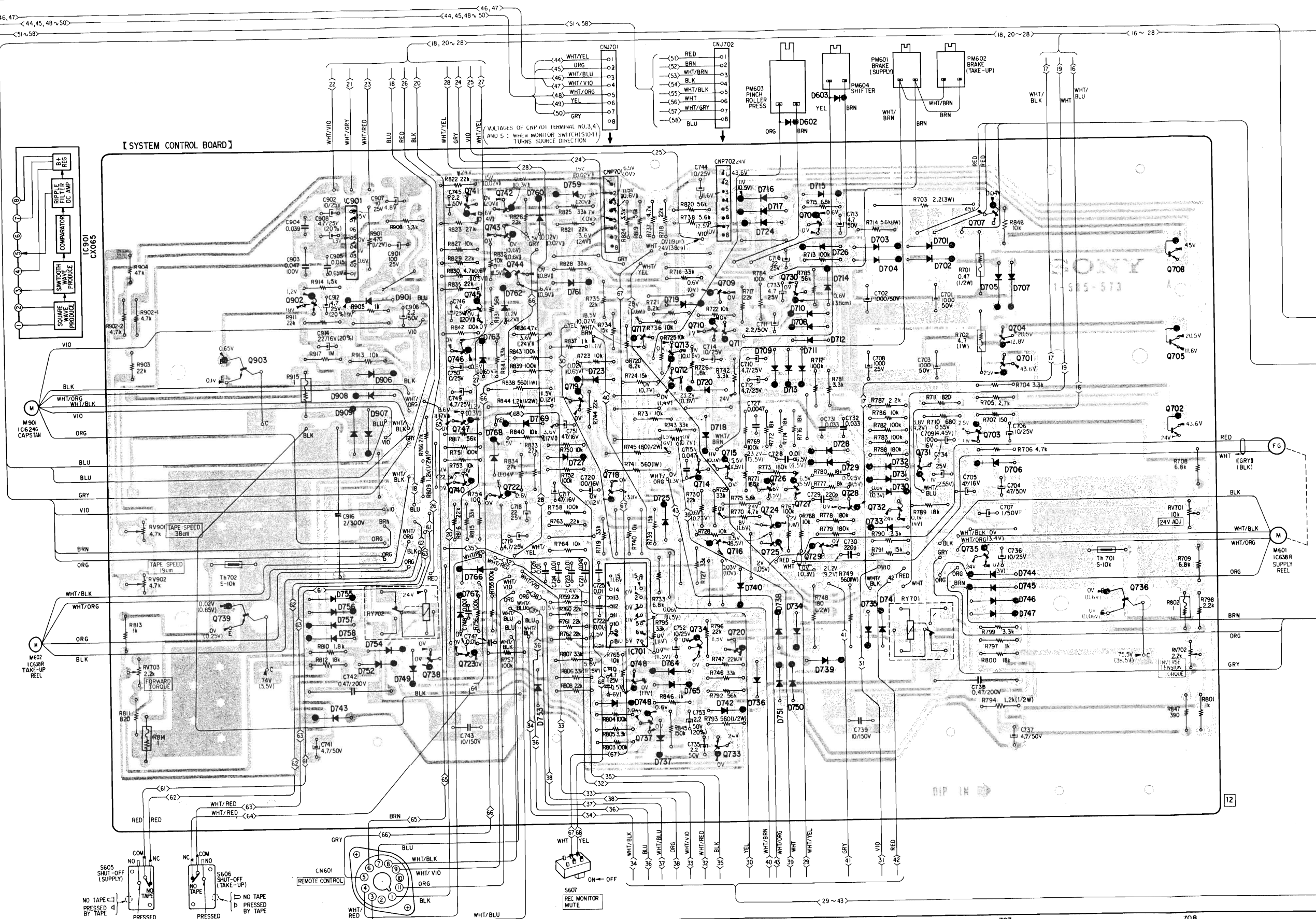

Q, IC	903	902	741	745	742	719	718	717	713	714	710	711	726	730	706	728	732	731	703	707	736	708	
D	739	755	756	757	743	747	748	749	763	762	769	760	759	723	748	737	765	719	720	740	736	701	702
		909	908	754	749	767	766	768	753	727	748	737	765	719	720	740	736	701	702	744	705	707	702
		907	752																	745	706	707	702
																				746	747		

# TC-766-2 TC-766-2

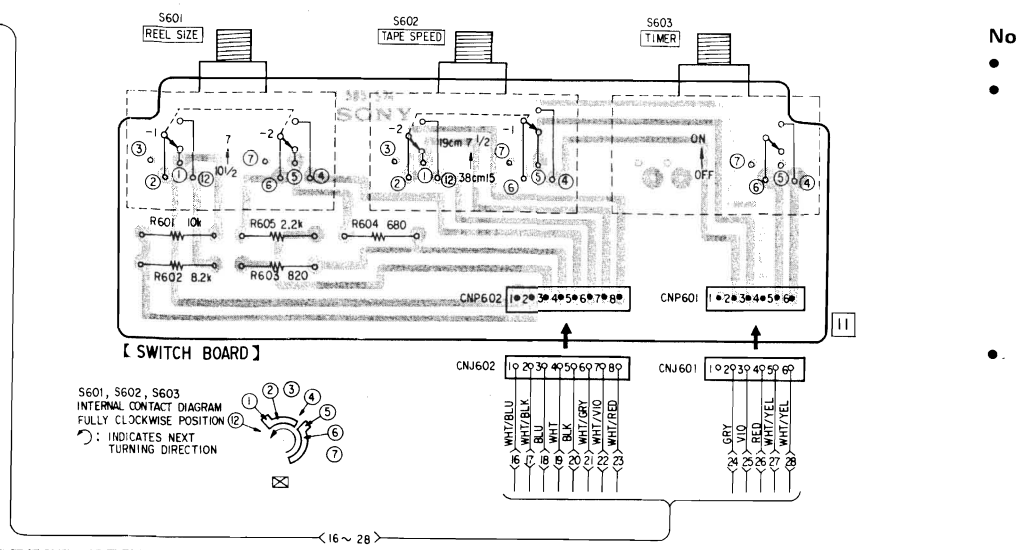
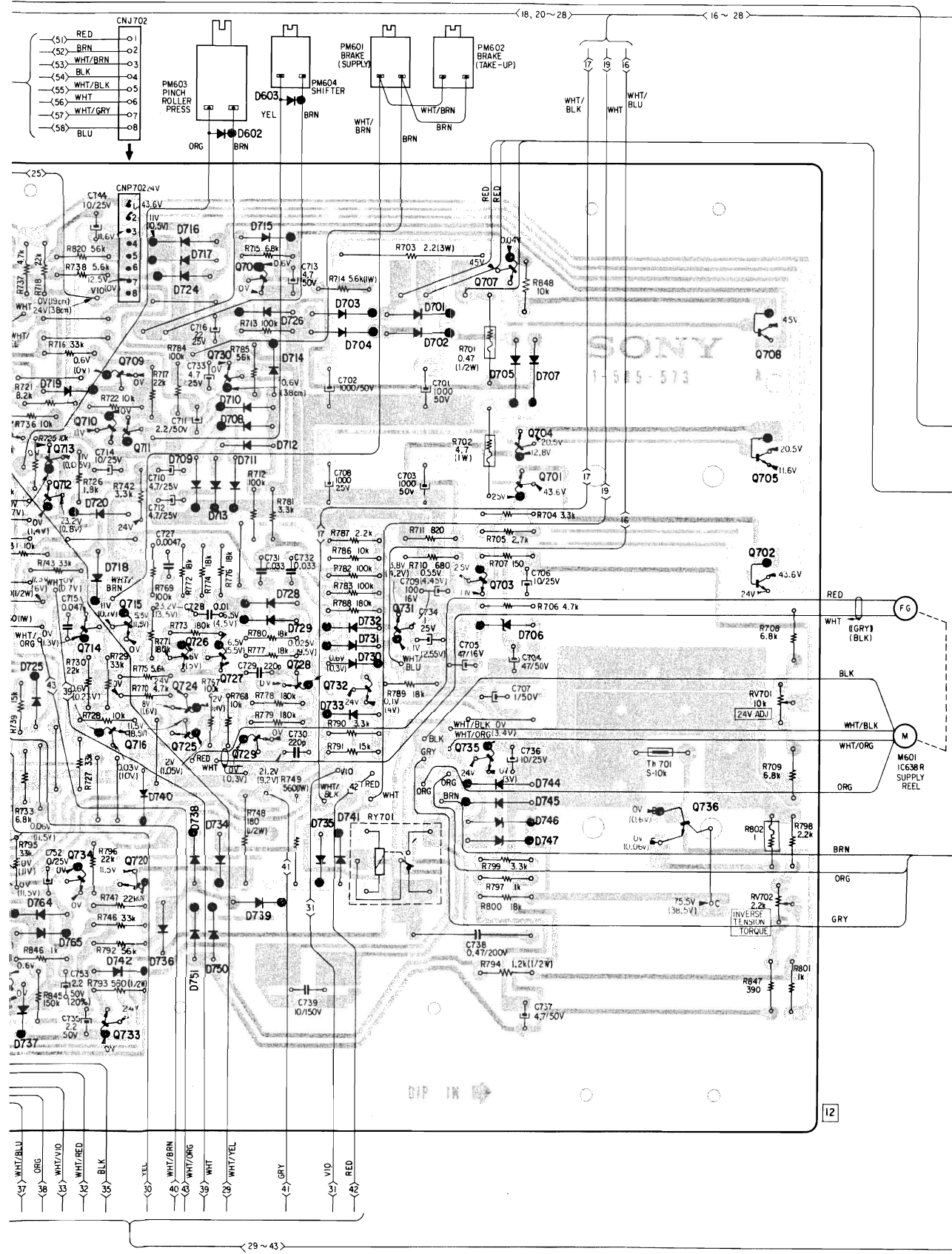

**Note:**

- ( ) : B+ pattern.
- Color code of sleeving over the end of the jacket.

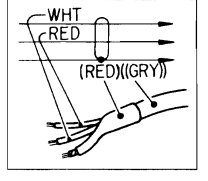

• Readings are taken in stop mode with a VOM (20 kΩ/V).

( ( ) ) : record mode.  
 ( ) : forward mode.  
 < ) : S607 is ON.

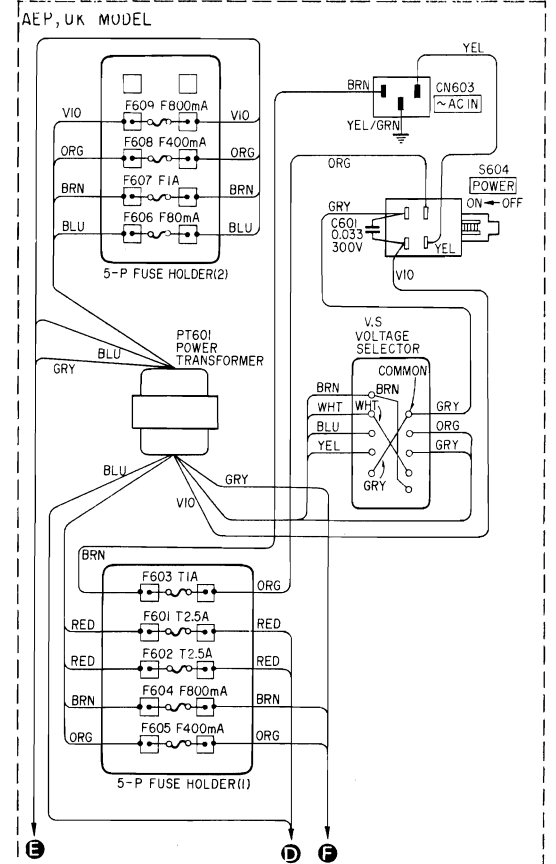
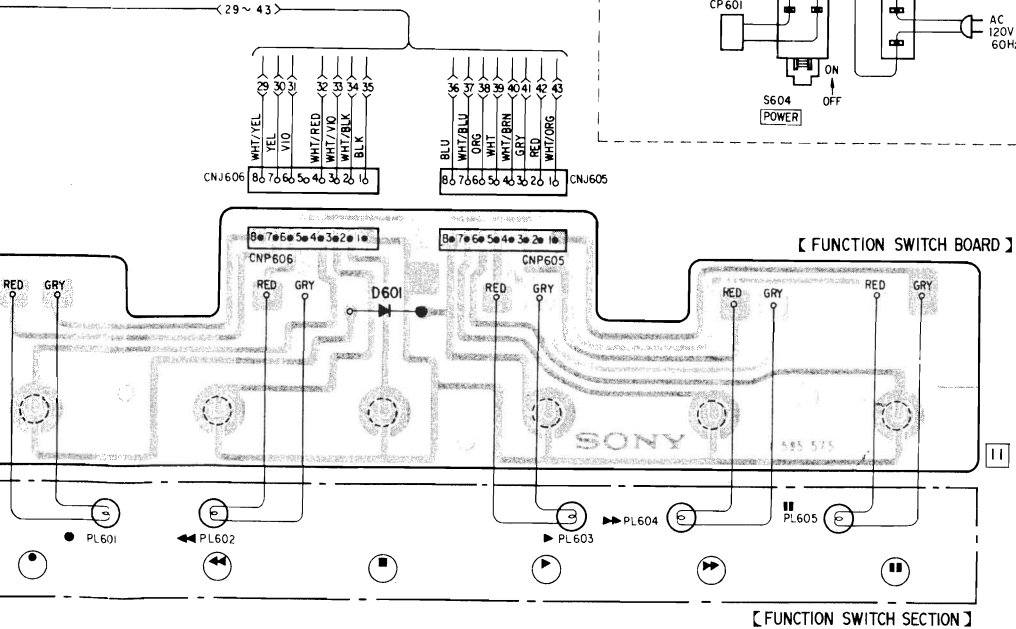
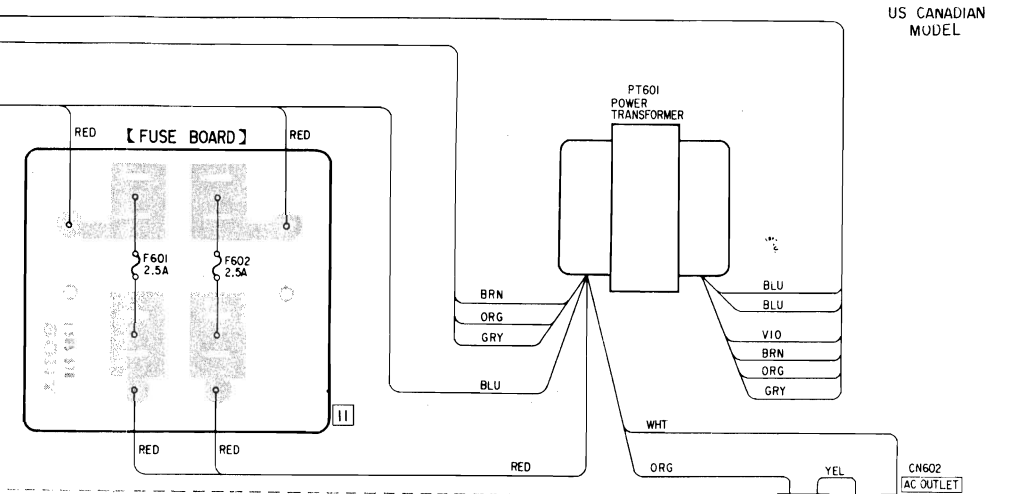

717	713	714	710	711	726	730	706	728	732	731	703	704	736	708	705		
	712	734	715		725	727	729				735	701			702		
737		733	716	720													Q, IC
	725	719	720		716	602	734	710	726	715	703	733	701	744	705	707	
	764		718	742	736	751	750	739	603	735	741	730	702	745	706		D
	737	765												746	747		

4.6. SCHEMATIC DIAGRAM – System Control Section –

Note: The components identified by shading are critical for safety. Replace only with part number specified.

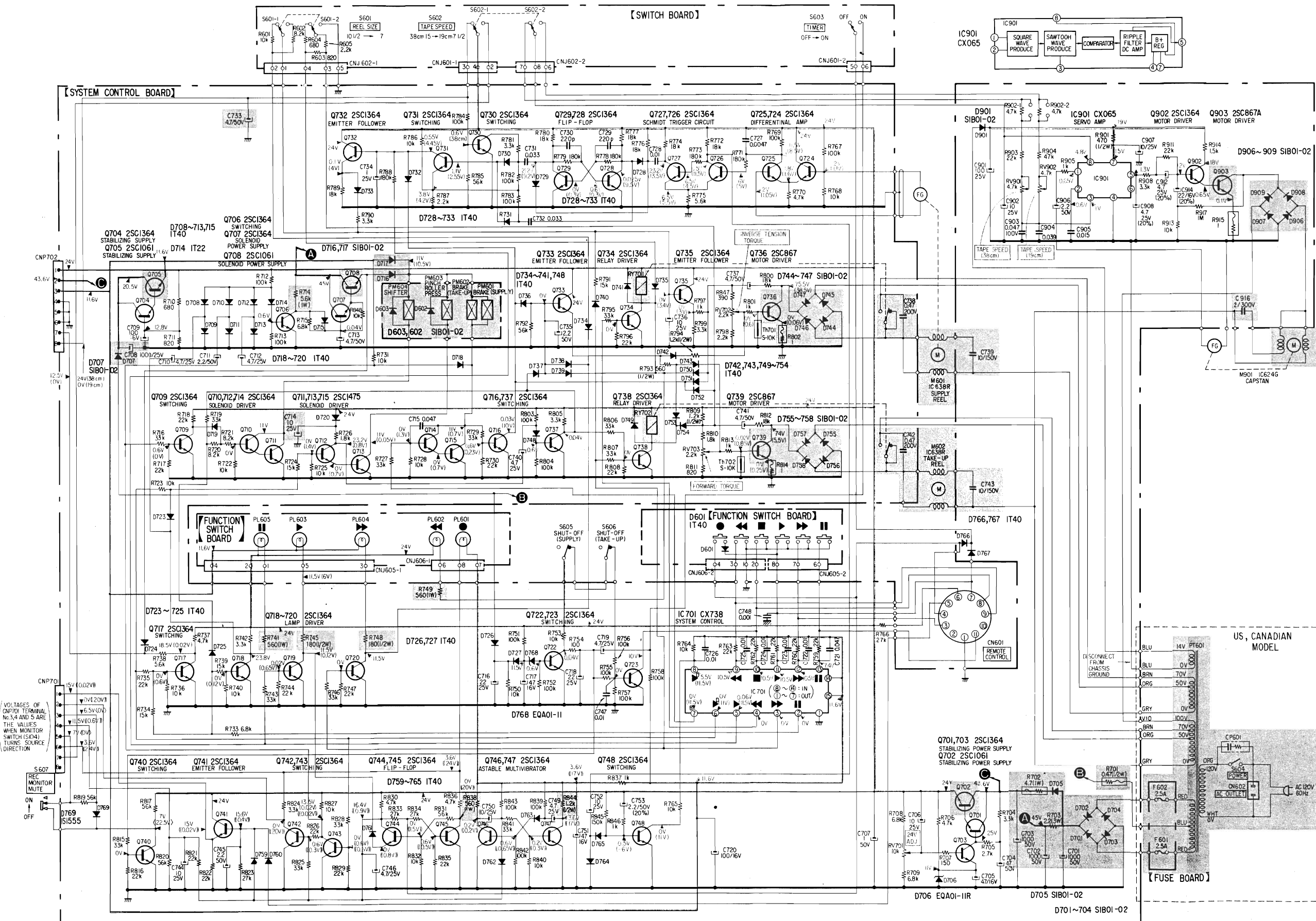

- Note:
- All capacitors are in μF unless otherwise specified. 50WV or less are not indicated except where noted.
  - All resistors are in ohms, 1/4W unless otherwise specified. kΩ = 1000Ω, MΩ = 1000kΩ
  - : fusible resistor.
  - (N) : low-noise capacitor and resistor.
  - 20% indicates component tolerance.
  - : B+ bus.
  - : panel designation.
  - : adjustment for repair.
  - : direct connection to points on chassis.
  - : chassis ground.
  - Voltages are dc with respect to ground unless otherwise noted.
  - Readings are taken in stop mode with the monitor switch (S604) in the following position:
    - (( )) : record mode.
    - ( ) : forward mode.
    - ( < ) : S607 is ON.
  - Voltage variations may be noted due to component tolerances.
  - Switch

Ref. No.	Switch
S601	REEL SIZE
S602	TAPE SPEED
S603	TIMER
S604	POWER
S605	SHUT-OFF (SUPPLY)
S606	SHUT-OFF (TAKE-UP)
S607	REC MONITOR MUT

VOLTAGES OF CNP70 TERMINAL No. 3, 4 AND 5 ARE THE VALUES WHEN MONITOR SWITCH (S604) TURNS SOURCE DIRECTION

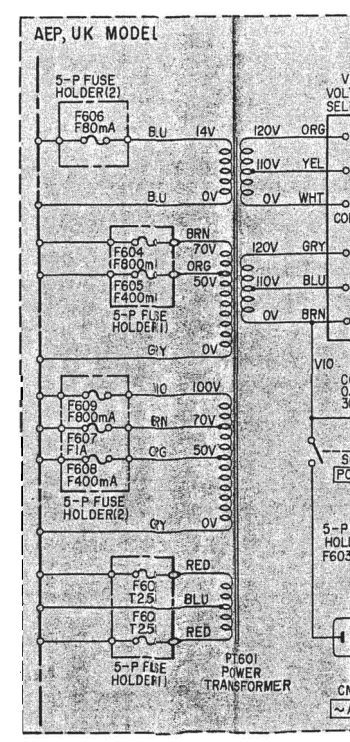



Note: The components identified by shading are critical for safety. Replace only with part number specified.

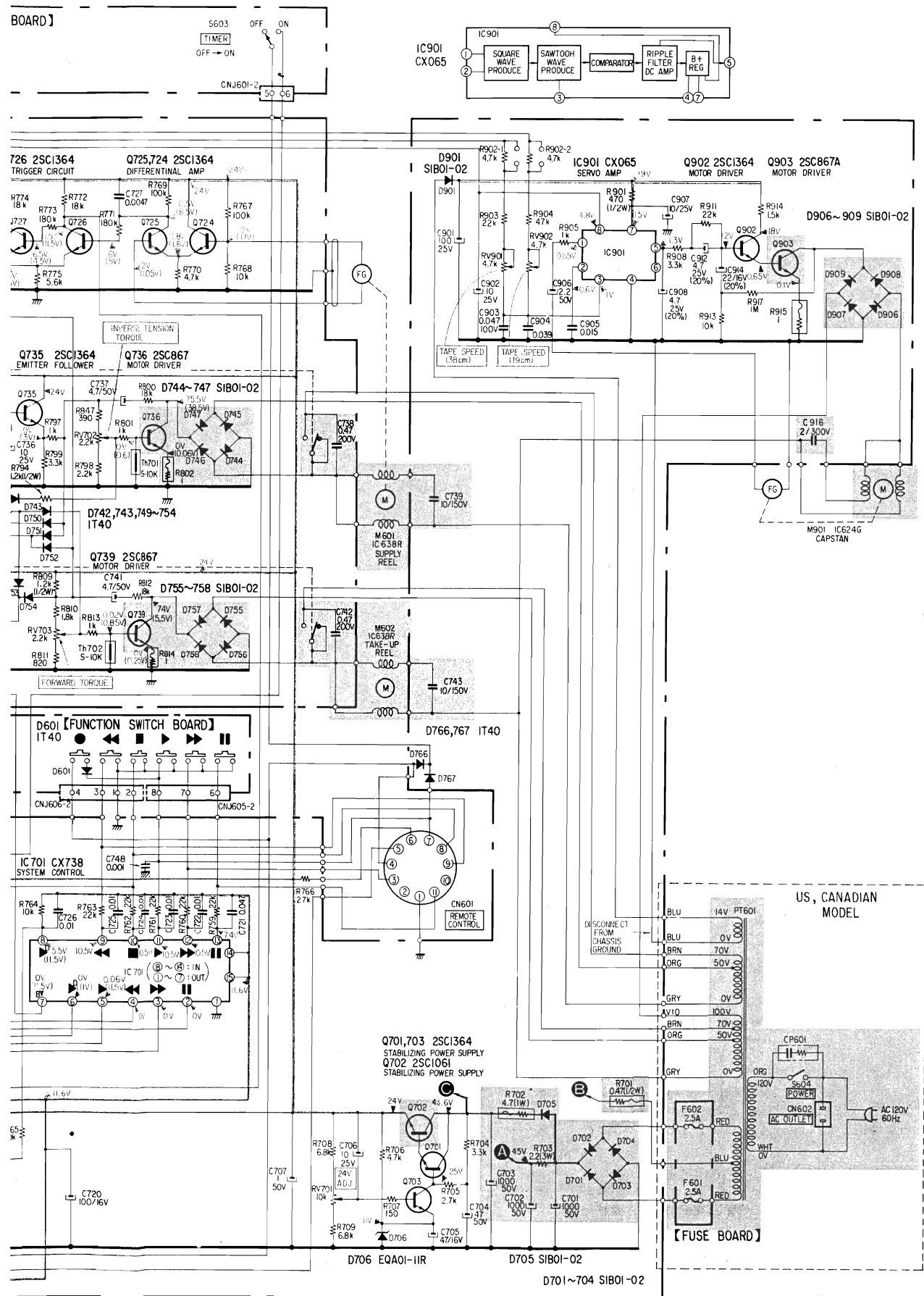

- Note:**
- All capacitors are in  $\mu\text{F}$  unless otherwise noted.  $\text{pF} = \mu\mu\text{F}$ . 50WV or less are not indicated except for electrolytics.
  - All resistors are in ohms,  $\frac{1}{2}\text{W}$  unless otherwise noted.  $\text{k}\Omega = 1000\Omega$ ,  $\text{M}\Omega = 1000\text{k}\Omega$
  - : fusible resistor.
  - (N) : low-noise capacitor and resistor.
  - 20% indicates component tolerance.
  - : B+ bus.
  - : panel designation.
  - : adjustment for repair.
  - : direct connection to points marked  $\equiv$  on the chassis.
  - : chassis ground.
  - Voltages are dc with respect to ground unless otherwise noted.
  - Readings are taken in stop mode with a VOM (20  $\text{k}\Omega/\text{V}$ ).
  - ( ) : record mode.
  - ( ) : forward mode.
  - < > : S607 is ON.
  - Voltage variations may be noted due to normal production tolerances.
  - Switch

Ref. No.	Switch	Position
S601	REEL SIZE	10 1/2
S602	TAPE SPEED	38 cm
S603	TIMER	OFF
S604	POWER	OFF
S605	SHUT-OFF (SUPPLY)	OFF
S606	SHUT-OFF (TAKE-UP)	OFF
S607	REC MONITOR MUTE	OFF

**Replacement Semiconductor**  
For replacement, use semiconductors except in ( ).

- Q701, 703, 704 : 2SC634A (2SC1364)
- Q706, 707, 709 : 2SC634A (2SC1364)
- Q716-720, 722-735 : 2SC634A (2SC1364)
- Q737, 738, 740-748 : 2SC634 (BLUE) (2SC1364)
- Q902 : 2SC634 (BLUE) (2SC1364)
- Q710, 712, 714 : 2SC634 (BLUE) (2SC1364)
- D601, 708-713 : 1S1555 (1T40)
- D715, 718-720 : 1S1555 (1T40)
- D723-743 : 1S1555 (1T40)
- D748-754 : 1S1555 (1T40)
- D759-767, 769 : 1S1555 (1T40)
- D714 : 1T22A (1T22)

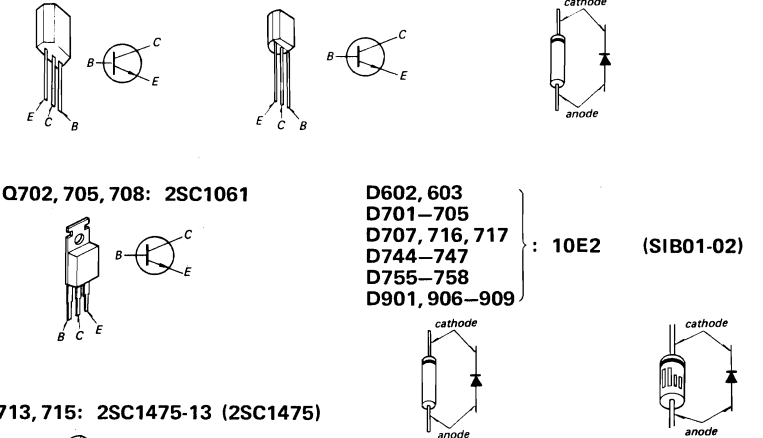

After replacing Q711, 713 or 715, change the resistor as follows.  
 Q711: R722 10  $\text{k}\Omega \rightarrow 8.2\text{k}\Omega$   
 Q713: R725 10  $\text{k}\Omega \rightarrow 8.2\text{k}\Omega$   
 Q715: R728 10  $\text{k}\Omega \rightarrow 8.2\text{k}\Omega$

Q736, 739: 2SC867A (2SC867)  
 Q903: 2SC867A

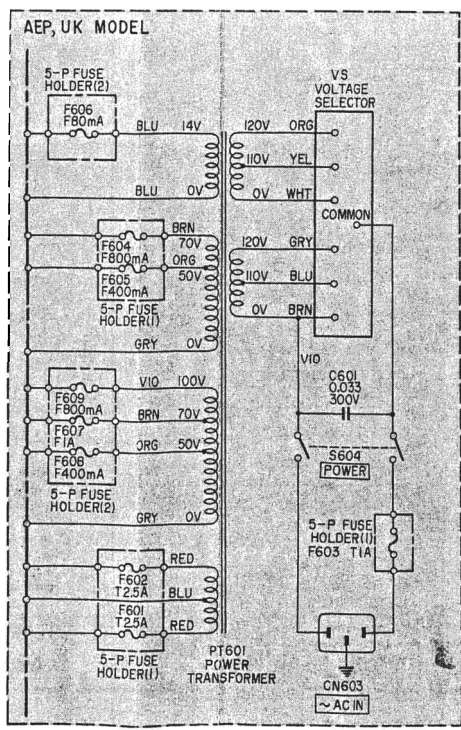
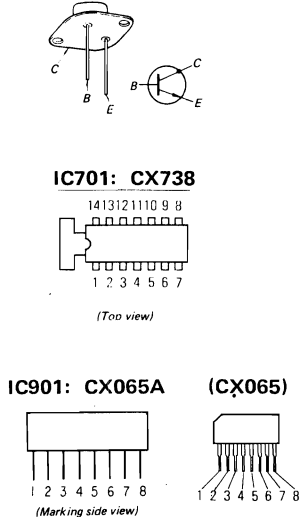

SECTION 5  
EXPLODED VIEWS

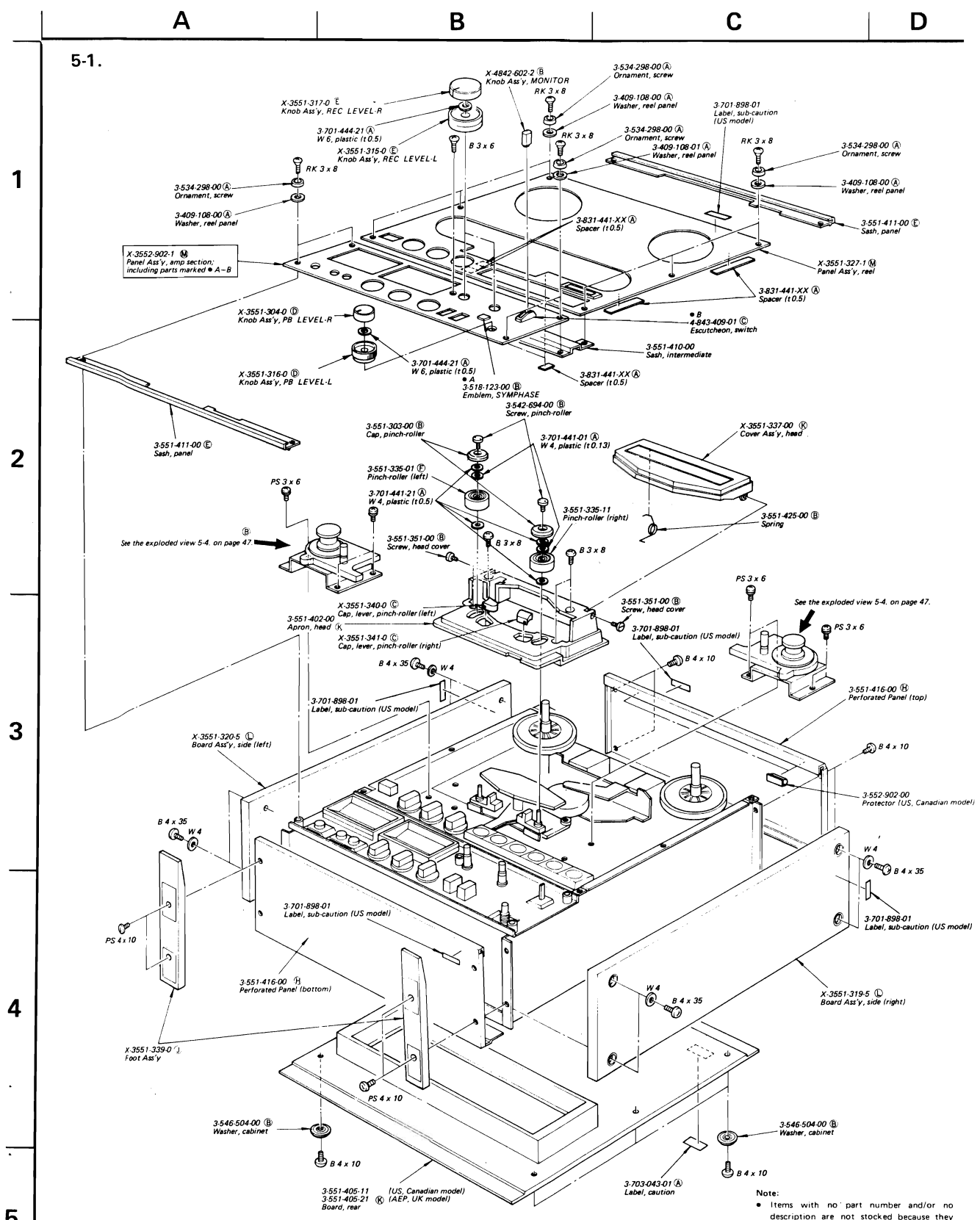

- 5
- Items with no part number and/or no description are not stocked because they are seldom required for routine service.
  - All screws are Phillips (cross recess) type unless otherwise noted.
  - (-) = slotted head
  - Circled letters (A) to (Z) are applicable to European models only.

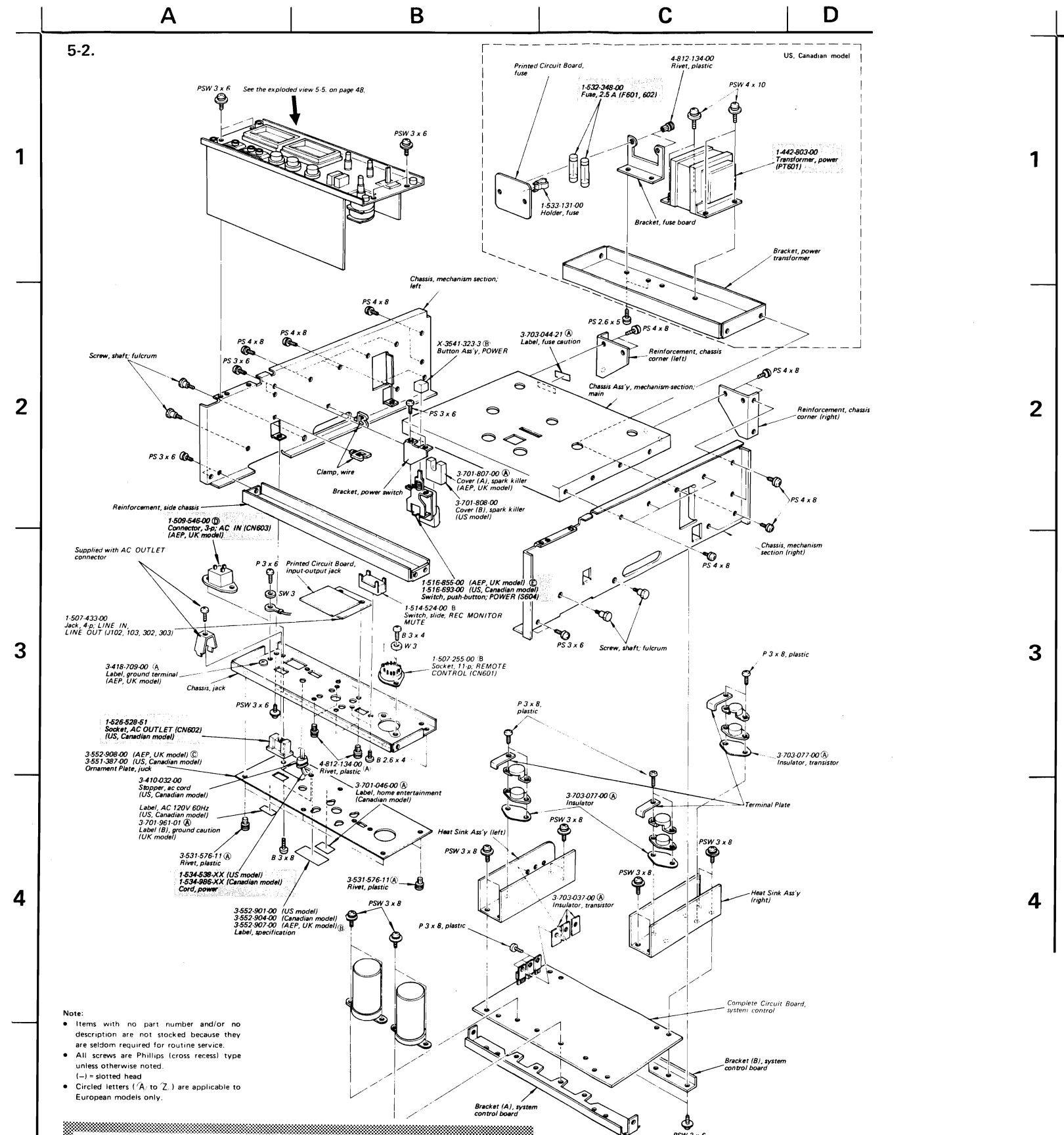

- 5
- Note: The components identified by shading are critical for safety. Replace only with part number specified.

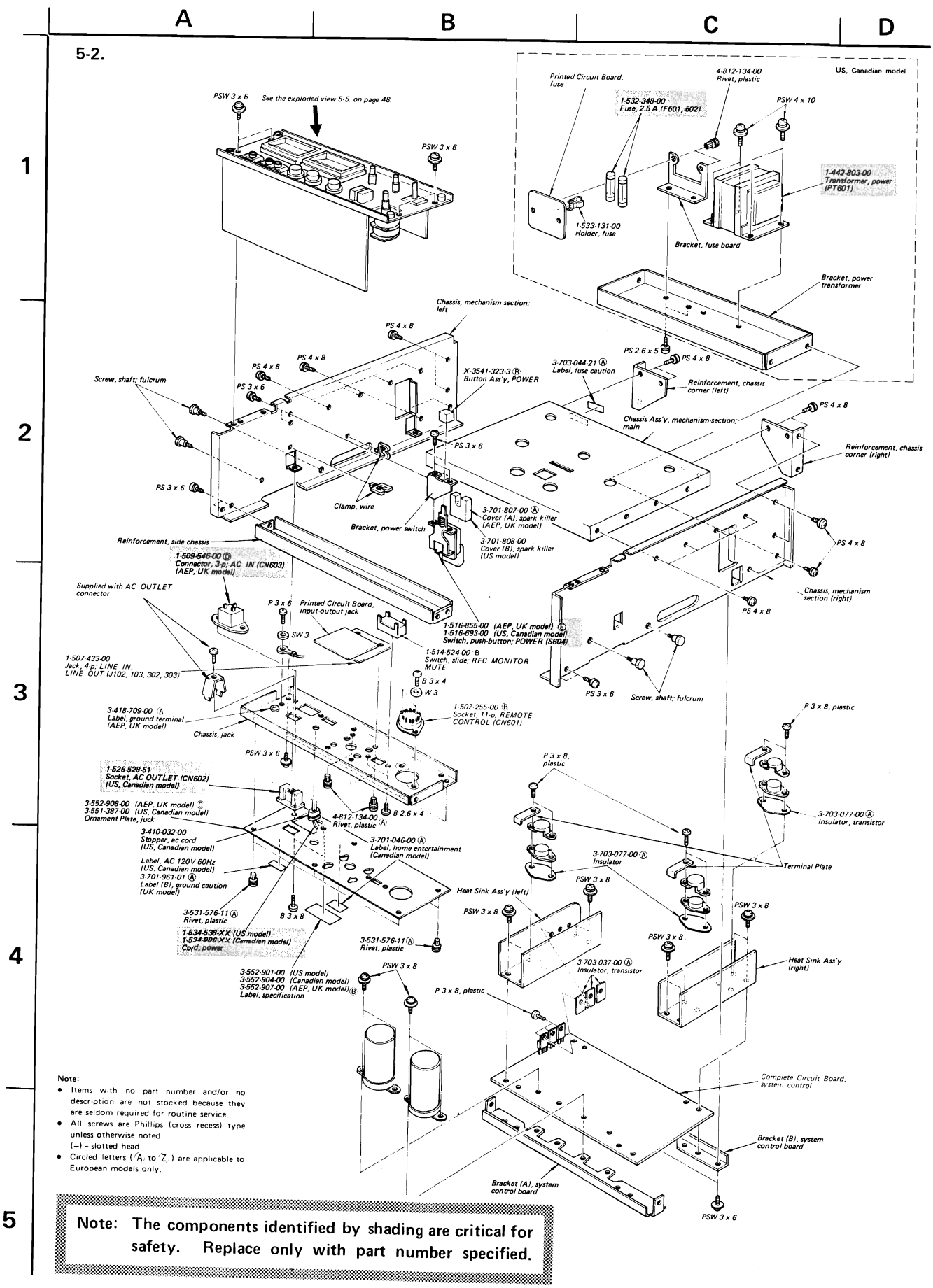

5

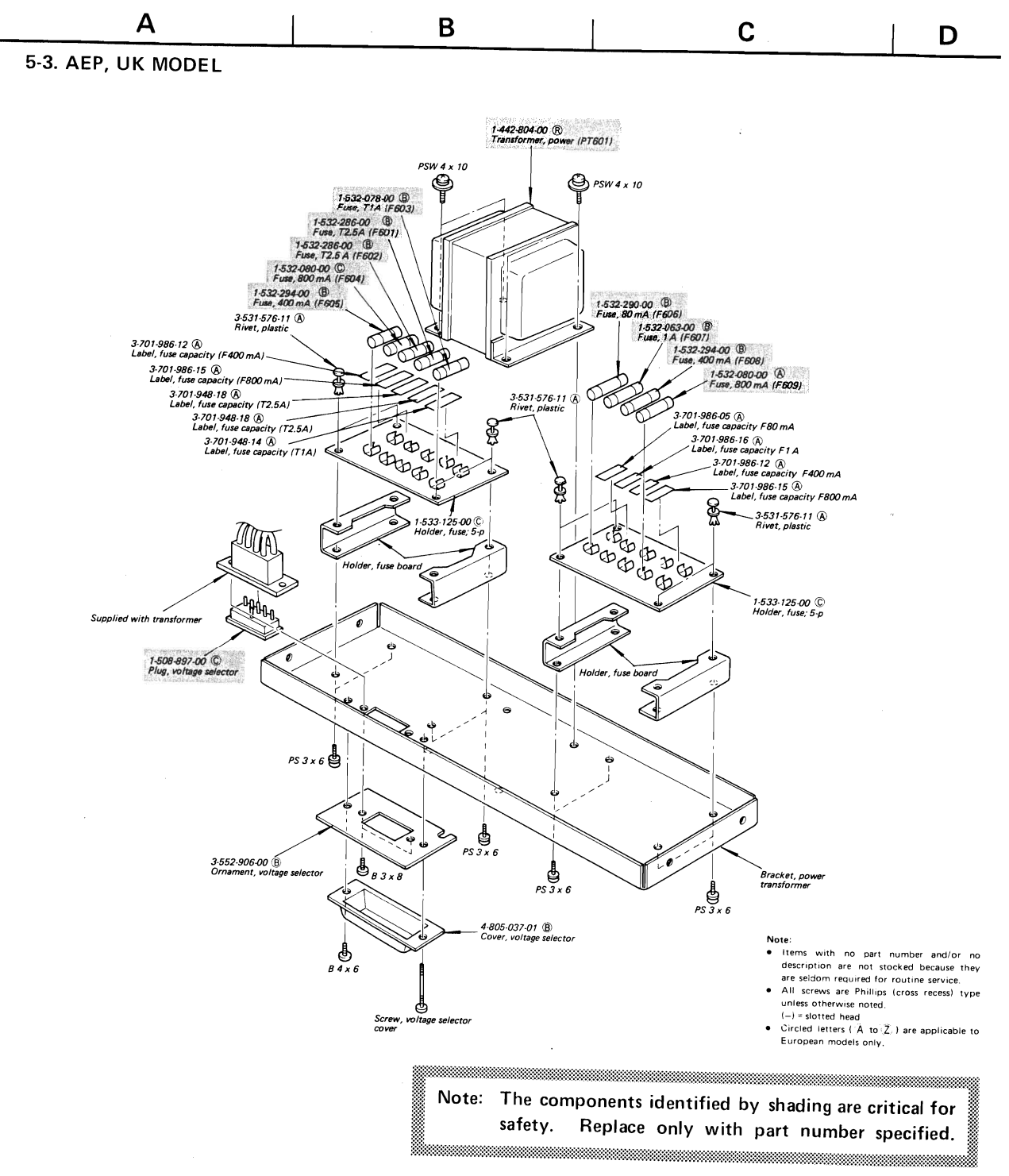

4

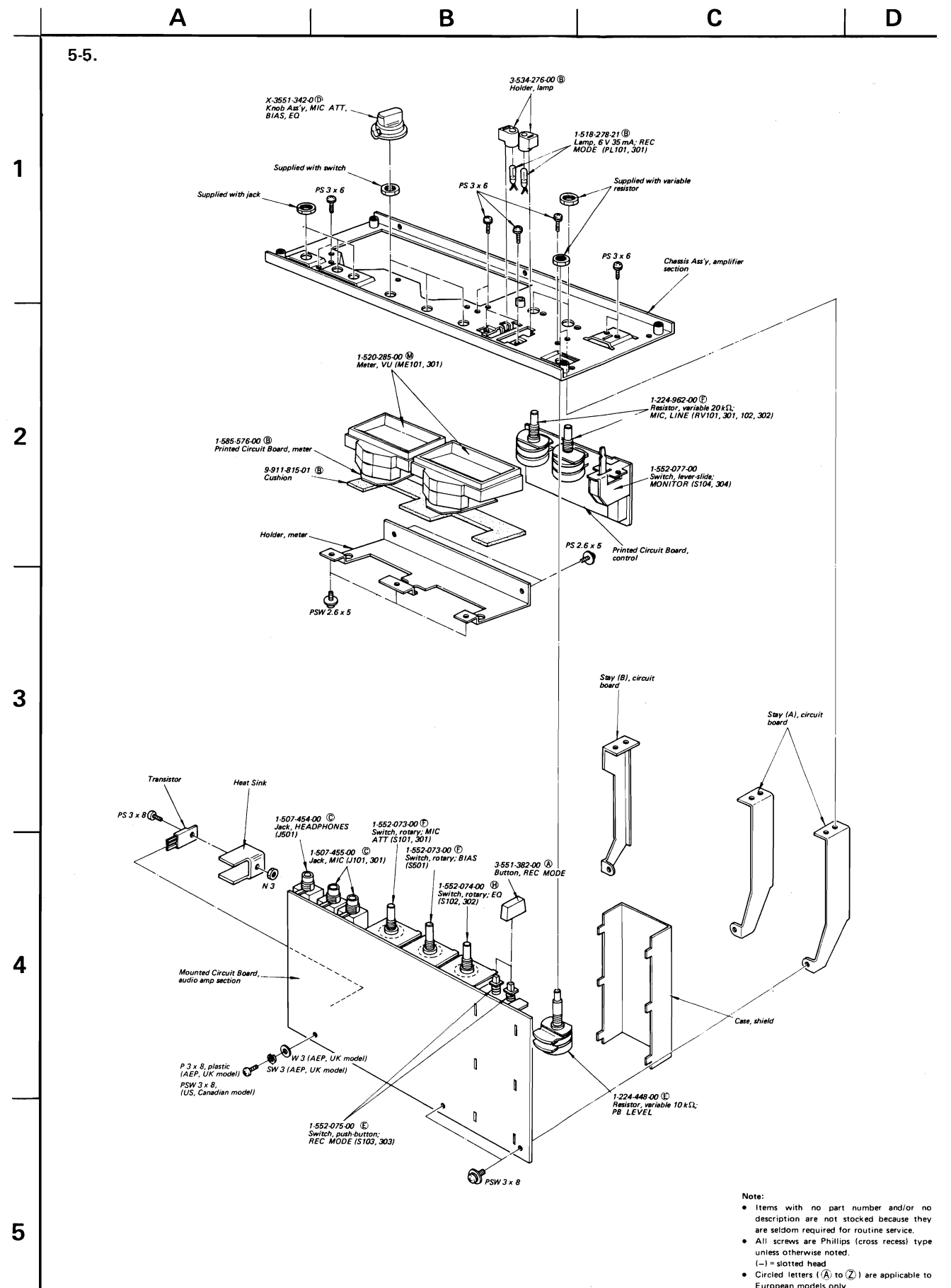
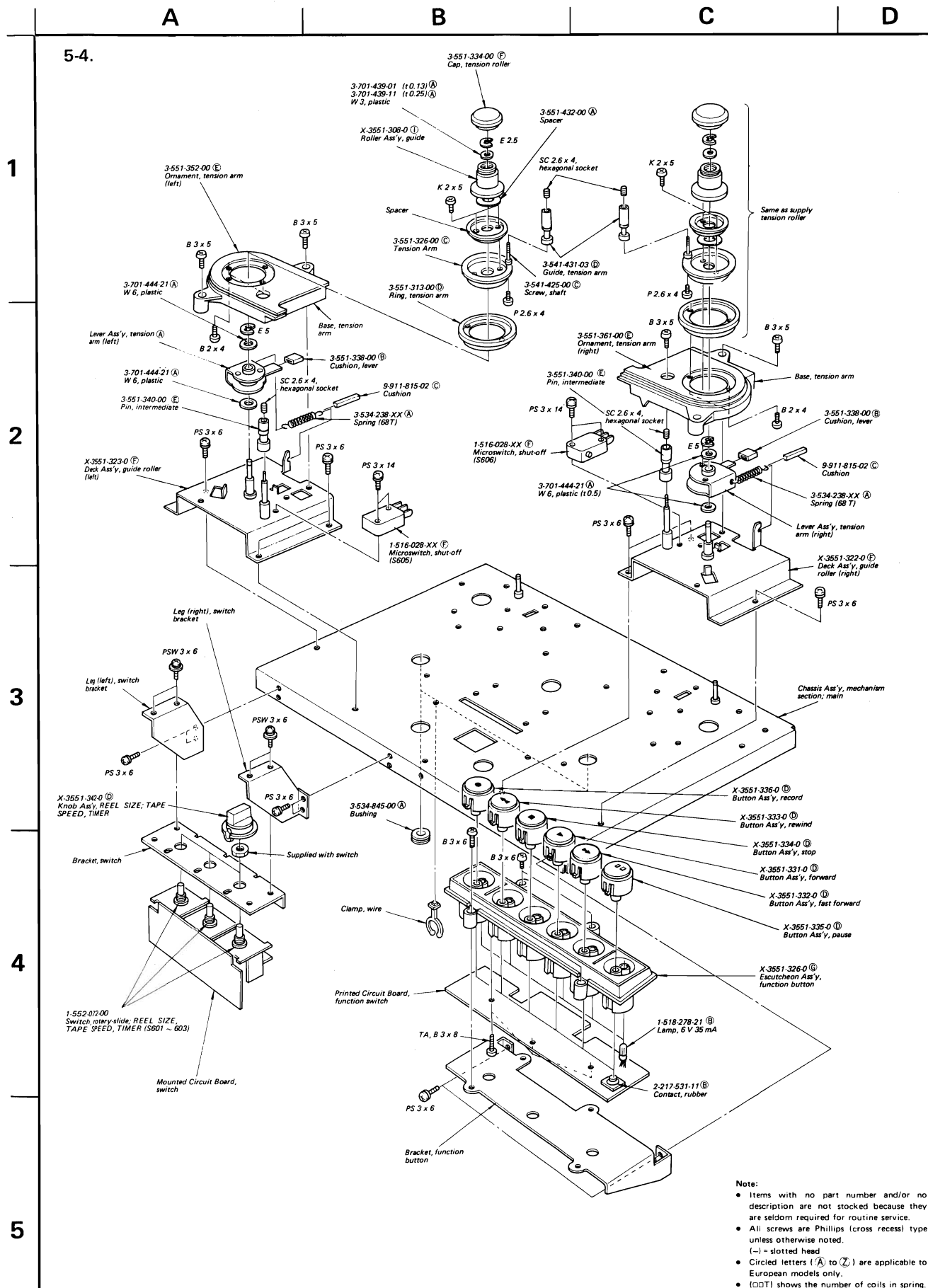

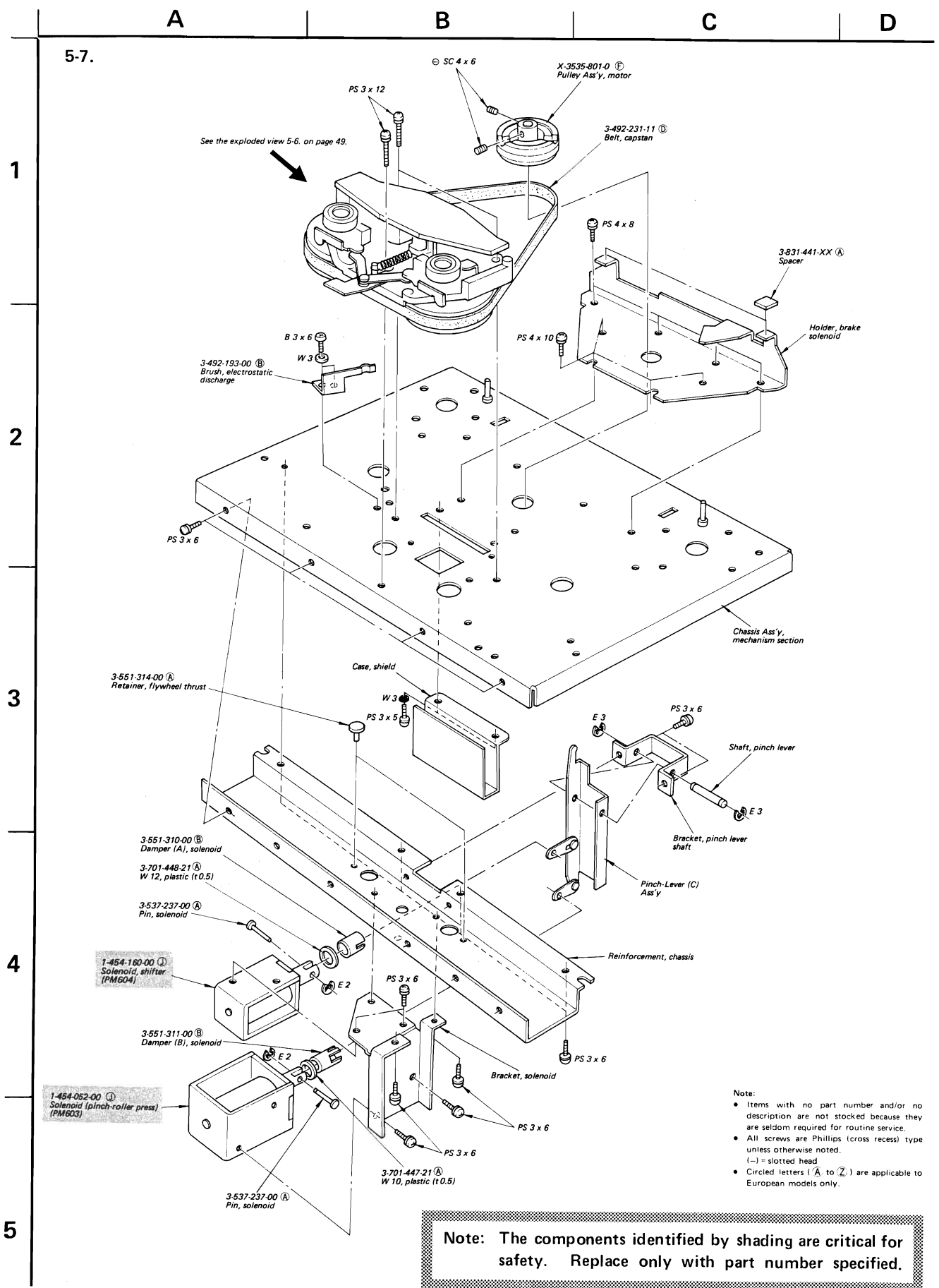
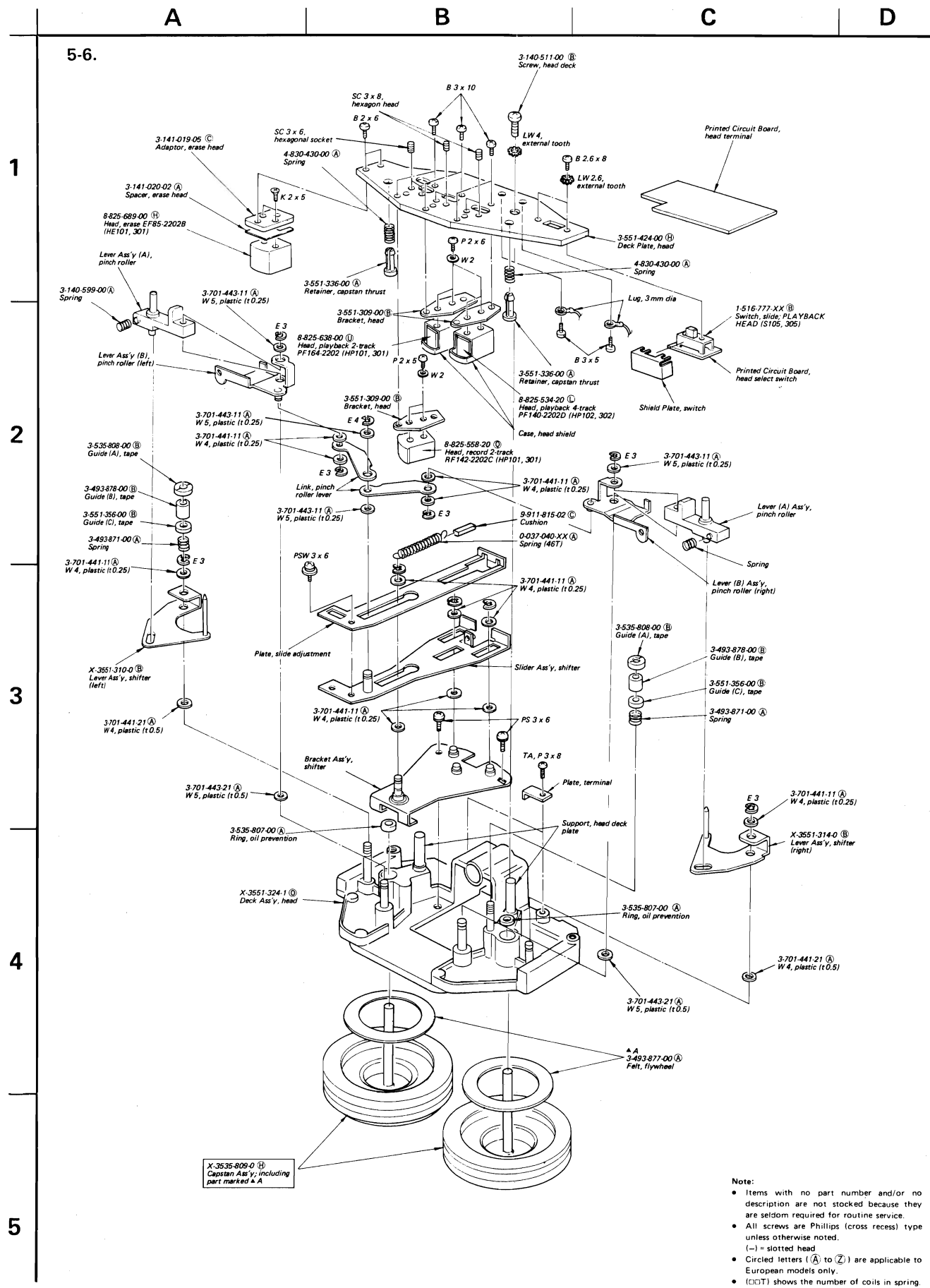



5-8.

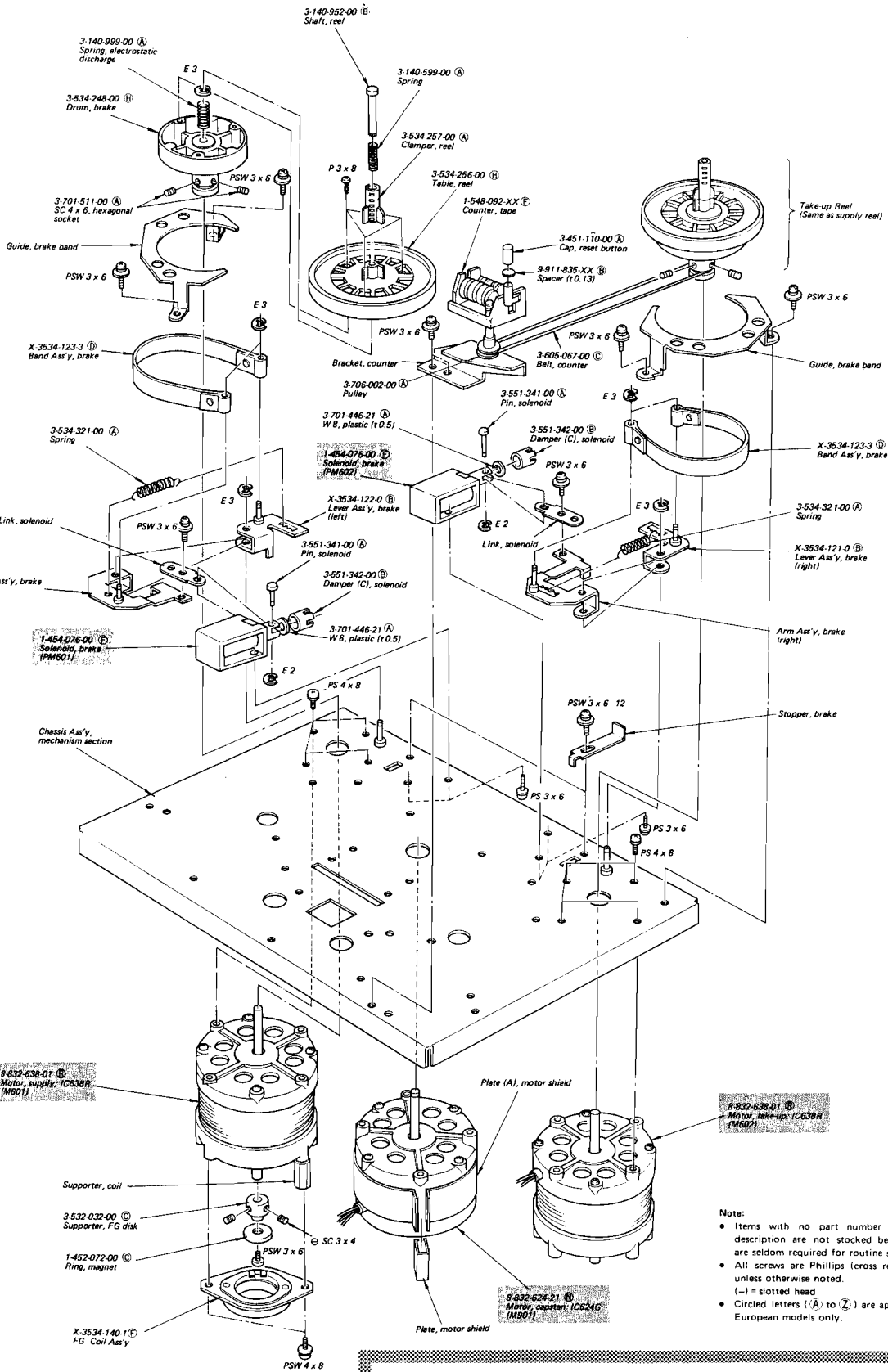

**Note:** The components identified by shading are critical for safety. Replace only with part number specified.

**Note:**  
 • Items with no part number and/or no description are not stocked because they are seldom required for routine service.  
 • All screws are Phillips (cross recess) type unless otherwise noted.  
 (-) = slotted head  
 • Circled letters (A) to (Z) are applicable to European models only.

## SECTION 6 ELECTRICAL PARTS LIST

**Note:**

- Circled letters (A) to (Z) are applicable to European models only.

<u>Ref. No.</u>	<u>Part No.</u>	<u>Description</u>	<u>Ref. No.</u>	<u>Part No.</u>	<u>Description</u>
<b>SEMICONDUCTORS</b>					
<b>Transistors</b>					
⇒ Q101-104, ⇒ Q301-304, ⇒ Q105-107, ⇒ Q305-307, ⇒ Q108,308	(B)	2SC1345-E	⇒ Q716-720, ⇒ Q722-735	(B)	2SC634A
⇒ Q109-114, ⇒ Q309-314, Q115,315 ⇒ Q116,316 Q117,317	(B)	2SC634A	⇒ Q736	(C)	2SC867A
⇒ Q120,320 Q121,321, Q122,322	(B)	2SC634A	⇒ Q737,738	(B)	2SC634A
⇒ Q123,124, ⇒ Q323,324	(B)	2SC1345-E	⇒ Q739	(C)	2SC867A
⇒ Q125,325 ⇒ Q126,326 ⇒ Q127,327	(B)	2SC634A	⇒ Q740-748	(B)	2SC634A
Q501 ⇒ Q502,503 Q504 ⇒ Q505 ⇒ Q507 ⇒ Q509	(C)	2SC1475	⇒ Q902	(B)	2SC634A
⇒ Q701	(B)	2SC1345-E (AEP, UK model)	Q903	(C)	2SC867A
⇒ Q702	(D)	2SA678 (AEP, UK model)	IC701	(K)	CX738
⇒ Q703,704	(B)	2SK30A	⇒ IC901	(F)	CX065A
⇒ Q705	(D)	2SC634A	<b>Diodes</b>		
⇒ Q706,707	(B)	2SC1173	⇒ D101,301, ⇒ D102,302	(B)	1S1555
⇒ Q708	(D)	2SC1475-13	⇒ D103,303	(B)	1T22A
⇒ Q709	(B)	2SC634A (AEP, UK model)	⇒ D501	(B)	EQB01-11Z
⇒ Q710	(B)	2SC634A	⇒ D502,503	(B)	1S1555
⇒ Q711	(C)	2SC1364 (Blue)	⇒ D505	(B)	1S1555 (AEP, UK model)
⇒ Q712	(B)	2SC1475-13	⇒ D601	(B)	1S1555
⇒ Q713	(C)	2SC634A	⇒ D602,603	(B)	10E2
⇒ Q714	(B)	2SC634A (AEP, UK model)	⇒ D701-705	(B)	10E2
⇒ Q715	(C)	2SC1475	⇒ D706	(B)	EQB01-11Z
			⇒ D707	(B)	10E2
			⇒ D708-713	(B)	1S1555
			⇒ D714	(B)	1T22A
			⇒ D715	(B)	1S1555
			⇒ D716,717	(B)	10E2
			⇒ D718-720	(B)	1S1555
			⇒ D723-743	(B)	1S1555
			⇒ D744-747	(B)	10E2
			⇒ D748-754	(B)	1S1555
			⇒ D755-758	(B)	10E2
			⇒ D759-767	(B)	1S1555
			⇒ D768	(B)	EQB01-11Z
			⇒ D769	(B)	1S1555
			⇒ D901	(B)	10E2
			⇒ D906-909	(B)	10E2
			Th701,702	1-800-204-00	(B) Thermistor, S-10K

**Note: The components identified by shading are critical for safety. Replace only with part number specified.**

- ⇒: Due to standardization, interchangeable replacements may be substituted for parts specified in the diagrams.

**Note:**

- Circled letters (A to Z) are applicable to European models only.

<u>Ref. No.</u>	<u>Part No.</u>	<u>Description</u>
<b>COILS</b>		
L101,301	1-407-593-00	(B) 27 mH, microinductor
L102,302	1-407-268-00	(B) 1.5 mH, variable inductor
L103,303	1-407-194-XX	(B) 820 μH, microinductor
L104,304	1-407-195-XX	(B) 680 μH, microinductor
L106,306	1-407-286-00	(B) 2.2 mH, variable inductor
L107,307	1-407-284-00	(B) 1 mH, variable inductor
<b>TRANSFORMERS</b>		
T101,301	1-427-284-00	(B) Output
<b>PT601</b>	1-442-803-00	Power (US, Canadian model)
	1-442-804-00	(R) Power (AEP, UK model)

**CAPACITORS**

All capacitors are in μF and electrolytic unless otherwise noted.  
50WV or less are not indicated except for electrolytics. pF = μμF

C101,301	1-131-193-11	(B) 10	10V	tantalum
C102,302	1-107-131-11	(A) 100p		silvered mica
C103,303	1-121-410-11	(B) 47	25V	
C104,304	1-131-190-11	(B) 22	6.3V	tantalum
C105,305	1-131-236-11	(B) 1	25V	tantalum
C106,306	1-107-073-11	(A) 33p		silvered mica
C107,307	1-131-192-11	(B) 4.7p	10V	tantalum
C108,308	1-121-416-11	(B) 100	25V	
C109,309	1-107-131-11	(A) 100p		silvered mica
C110,310	1-107-133-11	(A) 120p		silvered mica
C111,311	1-131-191-11	(B) 47	6.3V	tantalum
C112,312	1-131-207-11	(B) 4.7	25V	tantalum
C113,313	1-121-391-11	(A) 1	50V	
C114,314	1-108-816-12	(B) 0.1		mylar
C115,315	1-108-792-12	(A) 0.001		mylar
C116,316	1-131-193-11	(B) 10		tantalum
C117,317	1-121-654-11	(B) 330	25V	
C118,318	1-131-190-11	(B) 22	6.3V	tantalum
C119,319	1-121-805-11	(B) 330	10V	
C120,320	1-131-238-11	(B) 10	25V	tantalum

<u>Ref. No.</u>	<u>Part No.</u>	<u>Description</u>
C121,321	1-108-795-12	(A) 0.0018 mylar
C122,322	1-108-806-12	(A) 0.015 mylar
C123,323	1-108-805-12	(A) 0.012 mylar
C124,324 C125,325	1-108-803-12	(A) 0.0082 mylar
C126,326	1-108-802-12	(A) 0.0068 mylar
C127,327	1-108-803-12	(A) 0.0082 mylar
C128,328	1-108-799-12	(A) 0.0039 mylar
C129,329	1-107-185-11	(A) 470p 500V silvered mica
C130,330	1-107-037-11	(A) 82p 500V silvered mica
C131,331	1-107-163-11	(A) 47p 500V silvered mica
C132-134 C332-334	1-101-001-11	0.001 ceramic (US, Canadian model)
C135,335	1-141-010-XX	(B) Trimmer
C201,401	1-131-195-11	(B) 33 10V tantalum
C202,402	1-107-131-11	(A) 100p 50V silvered mica
C203,403	1-121-410-11	(B) 47 25V
C204,404	1-107-123-11	(A) 47p 50V silvered mica
C205,405	1-131-187-11	(B) 100 3.15V tantalum
C206,406	1-104-052-11	(B) 0.015 125V polystyrol
C207,407	1-131-238-11	(B) 10 25V tantalum
C208,408	1-103-765-11	(A) 390p polystyrol
C209,409	1-121-391-11	(A) 1 50V
C210,410	1-107-135-11	(A) 150p silvered mica
C211,411	1-107-135-11	(A) 150p silvered mica
C212,412	1-131-190-11	(B) 22 6.3V tantalum
C213,413	1-121-416-11	(B) 100 25V
C214,414	1-107-102-11	(A) 5p silvered mica
C215,415	1-131-195-11	(B) 33 10V tantalum
C216,416	1-108-810-12	(B) 0.033 mylar
C217,417	1-131-208-11	(C) 6.8V 25V tantalum
C218,418	1-107-123-11	(A) 47p silvered mica
C219,419	1-131-192-11	(B) 4.7 10V tantalum
C220,420	1-121-398-11	(A) 10 25V
C221,421	1-121-352-11	(A) 47 10V
C251,451	1-131-197-11	(B) 3.3 16V tantalum (AEP, UK model)
C252,452	1-107-139-11	(A) 220p silvered mica (AEP, UK model)
C253,453	1-131-207-11	(B) 4.7 25V tantalum (AEP, UK model)

**Note: The components identified by shading are critical for safety. Replace only with part number specified.**

**Note:**

- Circled letters (A to Z) are applicable to European models only.

<u>Ref. No.</u>	<u>Part No.</u>	<u>Description</u>	
C254,454	1-121-416-11	(B) 100	25V (AEP, UK model)
C501	1-121-738-11	(A) 10	50V
C502	1-121-415-11	(B) 100	16V
C503	1-121-480-11	(A) 22	25V
C504	1-121-398-11	(A) 10	25V
C505	1-121-450-11	(A) 2.2	50V
C506	1-129-703-11	(B) 0.0012	630V polyethylena
C507	1-108-804-12	(A) 0.01	mylar
C508-510	1-121-398-11	(A) 10	25V
C511	1-101-001-11	(A) 0.001	ceramic
C512,513	1-101-001-11	(A) 0.001	ceramic (AEP, UK model)
<b>C601</b>	<b>1-108-750-22</b>	<b>(C) 0.033</b>	<b>300V mylar</b> (AEP, UK model)
<b>C701-703</b>	<b>1-123-061-11</b>	<b>(C) 1000</b>	<b>50V</b>
C704	1-121-411-11	(B) 47	50V
C705	1-121-409-11	(A) 47	16V
C706	1-121-398-11	(A) 10	25V
C707	1-121-391-11	(A) 1	50V
<b>C708</b>	<b>1-121-657-11</b>	<b>(B) 1000</b>	<b>25V</b>
C709	1-121-415-11	(B) 100	16V
C710	1-121-395-11	(A) 4.7	25V
C711	1-121-450-11	(A) 2.2	50V
C712	1-121-395-11	(A) 4.7	25V
C713	1-121-396-11	(A) 4.7	50V
<b>C714</b>	<b>1-121-187-11</b>	<b>(A) 10</b>	<b>25V</b>
C715	1-108-246-12	(A) 0.047	mylar
C716	1-121-480-11	(A) 22	25V
C717	1-121-409-11	(A) 47	16V
C718	1-121-480-11	(A) 22	25V
C719	1-121-395-11	(A) 4.7	25V
C720	1-121-415-11	(B) 100	16V
C721	1-108-246-12	(A) 0.047	mylar
C722-726	1-108-239-12	(A) 0.01	mylar
C727	1-108-234-12	(A) 0.0047	mylar
C728	1-108-239-12	(A) 0.01	mylar
C729,730	1-102-110-11	(A) 220p	ceramic
C731,732	1-108-244-12	(A) 0.033	mylar
<b>C733</b>	<b>1-123-182-11</b>	<b>(A) 4.7</b>	<b>50V</b>

<u>Ref. No.</u>	<u>Part No.</u>	<u>Description</u>	
C734	1-131-236-11	(B) 1	25V tantalum
C735	1-121-450-11	(A) 2.2	50V
C736	1-121-398-11	(A) 10	25V
C737	1-121-396-11	(A) 4.7	50V
<b>C738</b>	<b>1-108-967-11</b>	<b>(C) 0.47</b>	<b>200V polyethylene</b>
<b>C739</b>	<b>1-117-100-11</b>	<b>(H) 10</b>	<b>150V metalized paper</b>
C740	1-121-395-11	(A) 4.7	25V
C741	1-121-396-11	(A) 4.7	50V
<b>C742</b>	<b>1-108-967-11</b>	<b>(C) 0.47</b>	<b>200V polyethylene</b>
<b>C743</b>	<b>1-117-100-11</b>	<b>(H) 10</b>	<b>150V metalized paper</b>
C744	1-121-398-11	(A) 10	25V
C745	1-121-450-11	(A) 2.2	50V
C746	1-121-395-11	(A) 4.7	25V
C747	1-108-239-12	(A) 0.01	mylar
C748	1-102-074-11	(A) 0.001	ceramic
C749	1-121-395-11	(A) 4.7	25V
C750	1-121-398-11	(A) 10	25V
C751	1-121-409-11	(A) 47	16V
C752	1-121-398-11	(A) 10	25V
C753	1-121-986-11	(A) 2.2	50V
C901	1-121-416-11	(B) 100	25V
C902	1-121-398-11	(A) 10	25V
C903	1-129-793-11	(B) 0.047	100V polyethylene
C904	1-108-593-12	(B) 0.039	mylar
C905	1-108-240-12	(A) 0.015	mylar
C906	1-121-450-11	(A) 2.2	50V
C907	1-121-398-11	(A) 10	25V
C908,912	1-121-961-11	(A) 4.7	25V
C914	1-121-990-11	(A) 22	16V
<b>C916</b>	<b>1-130-078-11</b>	<b>(F) 2</b>	<b>300V polyethylene</b>

## RESISTORS

All resistors are in ohms. Common 1/4W carbon resistors are omitted.  
Check schematic diagram for values.

R108,308	1-244-871-11	(A) 820	1/2W
R109	1-244-913-11	(A) 47k	1/2W
R111,311	1-244-889-11	(A) 4.7k	1/2W
R118,318	1-244-861-11	(A) 330	1/2W
R121,321	1-244-905-11	(A) 22k	1/2W

**Note:** The components identified by shading are critical for safety. Replace only with part number specified.

**Note:**

- Circled letters (A to Z) are applicable to European models only.

<u>Ref. No.</u>	<u>Part No.</u>	<u>Description</u>	
R125,325	1-244-909-11	(A) 33 k	½W
R127,327	1-244-885-11	(A) 3.3 k	½W
R138,338	1-244-873-11	(A) 1 k	½W
R140,340	1-244-897-11	(A) 10 k	½W
R141,341	1-244-875-11	(A) 1.2 k	½W
R146,346	1-217-401-11	(B) 150	¼W fuse (US, Canadian model)
R170,370	1-244-857-11	(A) 220	½W
R201,401	1-244-912-11	(A) 43 k	½W
R206,406	1-244-853-11	(A) 150	½W
R210,410 R212,412	1-244-885-11	(A) 3.3 k	½W
R213,413	1-244-927-11	(A) 180 k	½W
R231,431 R232,432	1-244-889-11	(A) 4.7 k	½W
R234,434	1-244-861-11	(A) 330	½W
R235,435	1-244-905-11	(A) 22 k	½W
R241,441	1-244-885-11	(A) 3.3 k	½W
R255,455	1-244-871-11	(A) 820	½W
R501	1-217-387-11	(B) 10	¼W fuse
R505,506	1-244-897-11	(A) 10 k	½W
R517	1-217-382-11	(B) 3.9	fuse (US, Canadian model)
R701	1-217-418-11	(B) 0.47	½W fuse
R702	1-217-477-11	(B) 4.7	1W fuse
R703	1-206-495-11	(B) 2.2	3W metal oxide
R714	1-213-152-11	(A) 5.6 k	1W metal oxide
R741	1-213-140-11	(A) 560	1W metal oxide
R745,748	1-244-855-11	(A) 180	½W
R749	1-213-140-11	(A) 560	1W metal oxide
R793	1-244-867-11	(A) 560	½W
R794	1-244-875-11	(A) 1.2 k	½W
R802	1-217-375-11	(B) 1	¼W fuse
R809	1-244-875-11	(A) 1.2 k	½W
R814	1-217-375-11	(B) 1	¼W fuse
R838	1-213-140-11	(A) 560	1W metal oxide
R844	1-244-875-11	(A) 1.2 k	½W
R901	1-244-865-11	(A) 470	½W
R903	1-212-622-11	(B) 22 k	¼W metal oxide
R904	1-212-630-11	(B) 47 k	¼W

<u>Ref. No.</u>	<u>Part No.</u>	<u>Description</u>
RV101,301 RV102,302	1-224-962-00	(F) 20 k, variable; MIC, LINE
RV103,303 RV104,304	1-224-646-XX	(B) 22 k, adjustable
RV105,305	1-224-448-00	(E) 10 k, variable; PB LEVEL
RV106,306	1-224-645-XX	(B) 2.2 k, adjustable
RV701	1-224-645-XX	(B) 10 k, adjustable
RV702,703	1-224-643-XX	(B) 2.2 k, adjustable
RV901,902	1-224-490-00	(B) 4.7 k, adjustable

**SWITCHES**

S101,301	1-552-073-00	(F) Rotary Slide, MIC ATT
S102,302	1-552-074-00	(H) Rotary Slide, EQ
S103,303	1-552-075-00	(E) Push Button, REC MODE
S104,304	1-552-077-00	(B) Lever Slide, MONITOR
S105,305	1-516-777-XX	(B) Slide, PLAYBACK HEAD
S106,306	1-516-778-XX	(C) Slide, INPUT SELECT (AEP, UK model)
S501	1-552-073-00	(F) Rotary, BIAS
S601-602	1-552-072-00	(F) Rotary, REEL SIZE, TAPE SPEED, TIMER
S604	1-516-693-00	Push Button, POWER (US, Canadian model)
	1-516-855-00	(E) Push Button, POWER (AEP, UK model)
S605,606	1-516-028-XX	(F) Micro, shut off
S607	1-514-524-00	(B) Slide, REC MONITOR MUTE

**JACKS**

J101,301	1-507-455-00	(C) MIC
J102,302 J103,303	1-507-433-00	(C) 4p, phono; LINE IN, LINE OUT
J501	1-507-454-00	(C) HEADPHONES

**FUSES**

F601,602	1-532-269-XX	Fuse, 2.5 A (US, Canadian model)
	1-532-286-00	(B) Fuse, T2.5 A (AEP, UK model)

**Note: The components identified by shading are critical for safety. Replace only with part number specified.**

**Note:**

- Circled letters (A) to (Z) are applicable to European models only.

Ref. No.	Part No.	Description
F603	1-532-078-00	(B) Fuse, T1A (AEP, UK model)
F604	1-532-080-00	(B) Fuse, 800 mA (AEP, UK model)
F605	1-532-294-00	(B) Fuse, 400 mA (AEP, UK model)
F606	1-532-290-00	(B) Fuse, 80 mA (AEP, UK model)
F607	1-532-063-00	(S) Fuse, 1A (AEP, UK model)
F608	1-532-294-00	(B) Fuse, 400 mA (AEP, UK model)
F609	1-532-080-00	(B) Fuse, 800 mA (AEP, UK model)

Ref. No.	Part No.	Description
	1-452-072-00	(C) Ring, magnet
	1-464-029-00	(G) Osc Unit
	1-508-897-00	(C) Plug, voltage selector (AEP, UK model)
	1-533-125-00	(C) Holder, fuse; 5-p (AEP, UK model)
	1-533-131-00	Holder, fuse (US, Canadian model)
	1-534-538-XX	Cord, power (US model)
	1-534-986-XX	Cord, power (Canadian model)

**MISCELLANEOUS**

CN501	1-509-549-00	(B) Connector, REC/PB (AEP, UK model)
CN601	1-507-255-00	(B) Socket, 11 p; REMOTE CONTROL
CN602	1-526-528-00	Socket, AC OUTLET (US, Canadian model)
CN603	1-509-546-00	(D) Connector, 3-p; AC IN (AEP, UK model)
CP601	1-231-341-00	Encapsulated Component (Canadian model)
	1-231-326-00	Encapsulated Component (US model)

HE101,301	8-825-689-00	(H) Head, erase; EF85-2202B
HP101,301	8-825-638-00	(U) Head, playback; PF164-2202
HP102,302	8-825-534-20	(L) Head, playback; PF140-2202D
HR101,301	8-825-558-20	(Q) Head, record; RF142-2202C

M601,602	8-832-638-04	(R) Motor, reel; IC638R
M901	8-832-624-21	(N) Motor, IC624G
ME101,301	1-520-285-00	(M) Meter, VU

PL101,301	1-518-278-21	(B) Lamp, 6V 35 mA
PL601-605		
		PL101,301: REC MODE
		PL601-605: pilot

PM601,602	1-454-076-00	(F) Solenoid, brake
PM603	1-454-052-00	(J) Solenoid, pinch roller
PM604	1-454-160-00	(J) Solenoid, shifter

RY501	1-515-267-00	(F) Reed Relay
RY503	1-515-267-00	(F) Reed Relay (AEP, UK model)
RY701,702	1-515-216-00	(F) Relay

**ACCESSORIES & PACKING MATERIALS**

Part No.	Description
A-2500-027-A	RM-30 (US, Canadian model)
X-3552-901-0	Carton Ass'y (US model)
X-3552-903-0	(K) Carton Ass'y (Canadian, AEP, UK model)
1-534-049-31	(F) Cord, connection, RK-74H
1-534-819-00	(G) Cord, power (UK, model)
3-401-193-00	Ribbon, head cleaning (US model)
3-534-322-00	(A) Cushion, reel table
3-534-327-00	(C) Case, reel
3-541-496-00	(D) Bag, protection
3-542-008-00	(C) Tips, head cleaning
3-542-101-00	(B) Adaptor, reel
3-551-428-00	(B) Cover, sheet
3-551-429-00	(B) Cushion, lower
3-551-430-00	(D) Cushion, upper
3-552-909-00	Carton, RM-30 (US, Canadian model)
3-701-628-00	Bag, plastic; RM-30 (US, Canadian model)
3-770-226-11	(I) Manual, instruction (AEP, UK model)
3-770-226-21	Manual, instruction (US model)
3-770-226-31	Manual, instruction (Canadian model)

**Note:** The components identified by shading are critical for safety. Replace only with part number specified.

**Sony Corporation**

© 1977

— 56 —

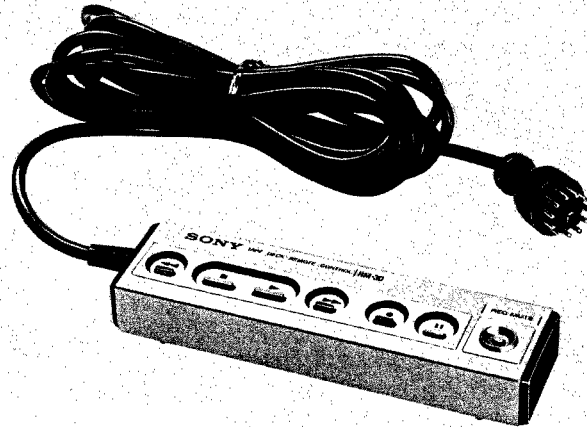

## REMOTE CONTROL

### 1. SPECIFICATIONS

**Dimensions:** 188 (w) x 33 (h) x 50 (d) mm  
 7 <sup>7</sup>/<sub>16</sub> (w) x 1 <sup>5</sup>/<sub>16</sub> (h) x 2 (d) inches

**Weight:** Approx. 630g (1 lb 7 oz) with cord

**Cord:** Approx. 4m (13 feet, 2 inches)

**Supplied Accessories:** Stand adaptor: SAD-24 (PF <sup>1</sup>/<sub>2</sub>' to U <sup>1</sup>/<sub>4</sub>')  
 Stand adaptor: SAD-25 (U <sup>5</sup>/<sub>16</sub>' to PF <sup>1</sup>/<sub>2</sub>')

### 2. BOTTOM PLATE ASS'Y REMOVAL

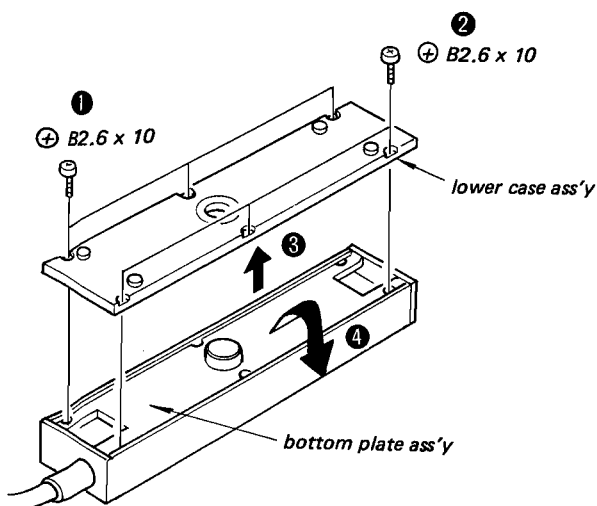

### 3. CONTACT RESISTANCE OF PUSH BUTTON

If the tape recorder does not operate properly by pushing the push button (REW, STOP, FWD, FF, REC, PAUSE or REC MUTE) on RM-30, supposing the contact resistance of the button is increased,

proceed the following steps to be the correct operation.

1. Disconnect RM-30 from the tape recorder.
2. Connect VOM as shown in Fig. 1. Then, push the each button one after another.
3. If the resistance value indicates more than 1 k-ohm, remove the lower case to take off the push button switch board. Then, clean the contact piece with a denatured-alcohol-moistened swab as shown in Fig. 2.

**Note:** Don't scrub the carbon granules strongly to avoid damage.

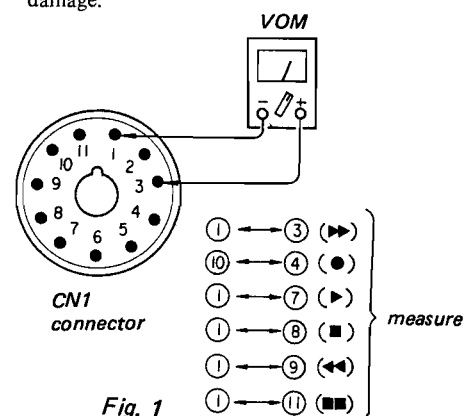

Fig. 1

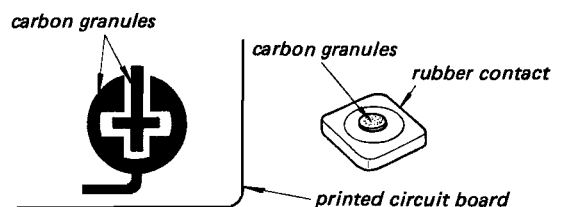

Fig. 2

## 4. CIRCUIT DESCRIPTION

When connecting RM-30 to the tape recorder, the push buttons except REC MUTE button are connected in parallel with the operation button on the tape recorder. Thus, the tape recorder is operated by the each push button on RM-30 as same as the tape recorder function button.

REC MUTE Operation (In the case that RM-30 is connected to EL-7.)

1. When pushing REC MUTE button, Q746 turned on. (route **A**)
2. Q501 turned off, so Q306 and Q307 turned on. (route **B**)
3. As the result, the recording signal is muted.

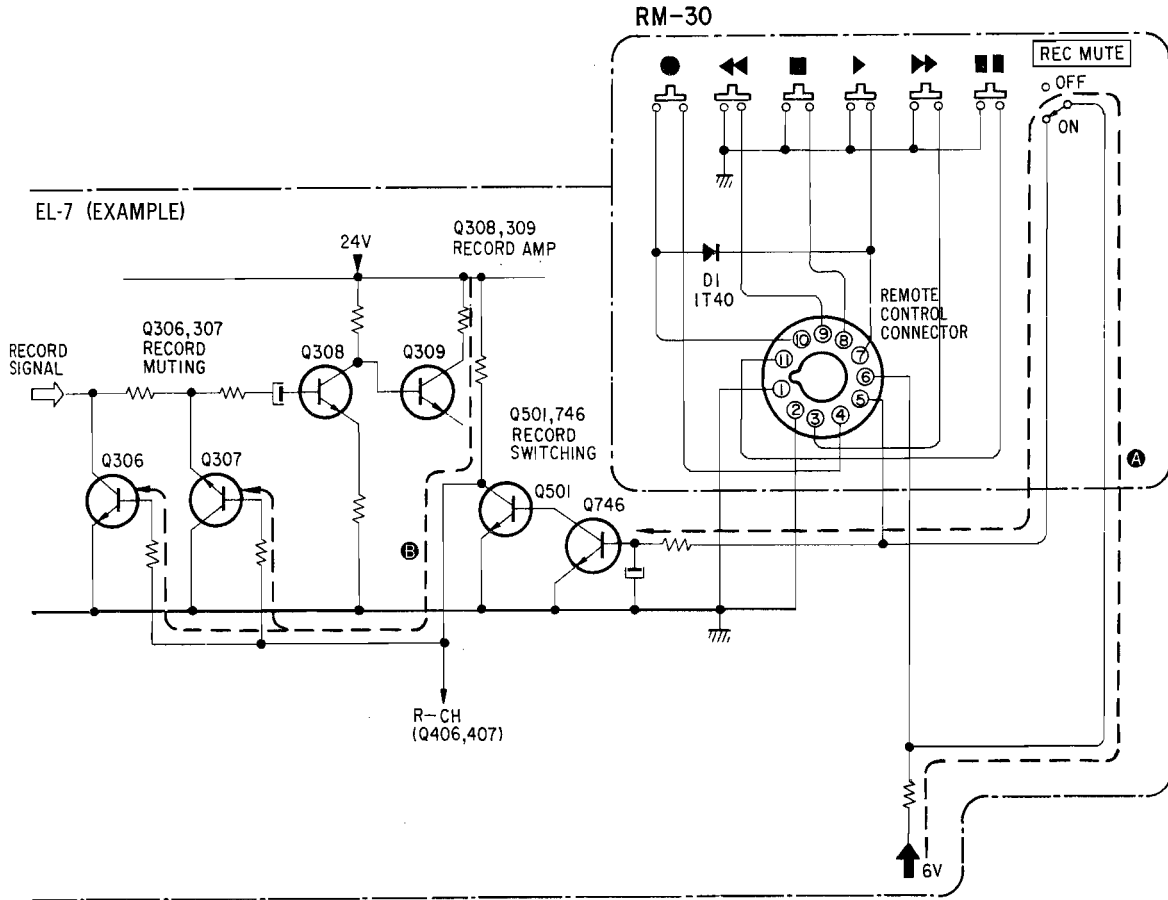
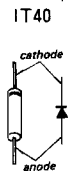
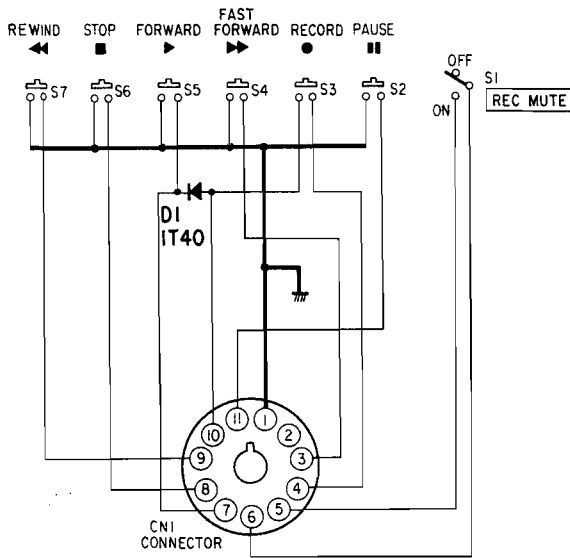

Fig. 3



**5. SCHEMATIC DIAGRAM**



**6. MOUNTING DIAGRAM**  
— Conductor Side —

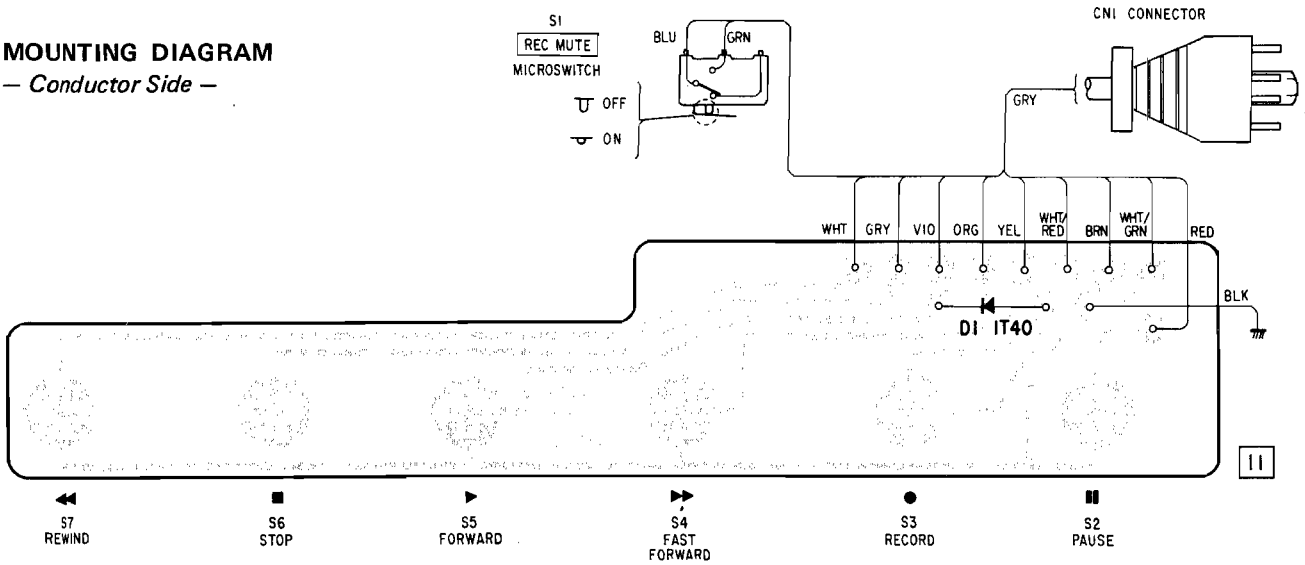

**7. ELECTRICAL PARTS LIST**

**ACCESSORIES AND PACKING MATERIALS**

<u>Ref. No.</u>	<u>Part No.</u>	<u>Description</u>
<b>SEMICONDUCTOR</b>		
D1	Ⓟ IT40	
<b>MISCELLANEOUS</b>		
S1	1-516-544-00	Ⓣ Microswitch, REC MUTE
	1-551-232-00	Ⓜ Cord, remote control (w/ Connector)

<u>Part No.</u>	<u>Description</u>
2-100-961-00	Ⓟ Adaptor, stand; SAD-24
2-236-617-00	Ⓟ Carton
2-521-203-00	Ⓧ Adaptor, stand; SAD-25
3-701-628-00	ⓐ Bag, plastic
3-770-034-11	Ⓟ Manual, instruction

• Circled letters (ⓐ to Ⓧ) are applicable to European models only.

**8. EXPLODED VIEW**

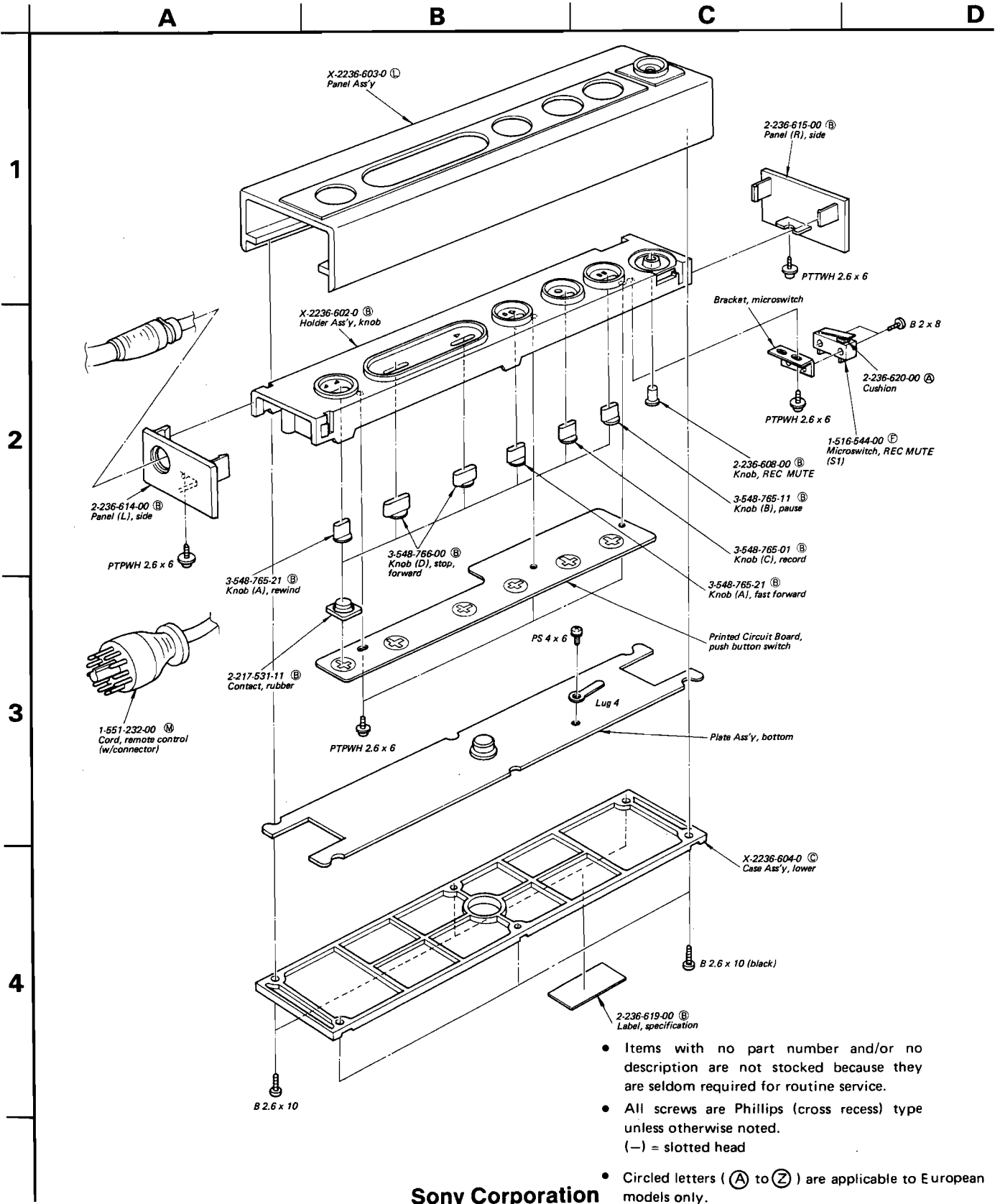

- Items with no part number and/or no description are not stocked because they are seldom required for routine service.
- All screws are Phillips (cross recess) type unless otherwise noted.  
(-) = slotted head
- Circled letters (A) to (Z) are applicable to European models only.

**Sony Corporation**

© 1976

-4-

*UK Model*  
*AEP Model*  
*US Model*

*Canadian Model*

## SUPPLEMENT

File this supplement with the service manual.

No. 1

October, 1977

### Subject: Circuit Description

The system control circuits of this tape recorder are activated by pushing the Feather-Touch operation buttons and control three kinds of movement for

four solenoids along with the voltage applied to the operating lamps and the reel motor.

Circuit descriptions are listed in the following order.

	<i>Page</i>
1. Action of IC701 (CX738) .....	2
2. Action when switcheded from Fast Forward or Rewind to Forward .....	3
3. Power Supply Section .....	3
4. High Voltage Power Supply for Solenoid Initial-Energization .....	4
5. Reel Motor Starting Circuit .....	5
6. Tension Regulator Circuit .....	5
7. Tape Tension Set-up and Circuit Operation .....	6
8. Mechanical Tension Regulator .....	7
9. Reel Motor Drive Circuit .....	7
10. Back Tension Set-up in Rewind Mode .....	8
11. Back Tension Set-up in Fast Forward Mode .....	9
12. STOP Circuit (Shut-off Circuit) .....	10
13. TIMER-Activated Operation .....	10
14. Playback Muting .....	11
15. Record Muting .....	12
16. REC MONITOR MUTE Circuit .....	13
17. Power Supply for Record Bias Oscillator .....	13
18. Function Button Action Flow Chart .....	15
• STOP → Forward, Forward/PAUSE → Forward .....	15
• Forward → Forward/PAUSE .....	16
• Record/Forward → Record/Forward/PAUSE .....	17
19. Circuit Operation .....	19
• Forward and Record .....	19
• PAUSE .....	21
• Fast Forward .....	23
• Rewind .....	25
20. Function Button Action Time Chart .....	27

## 1. Action of IC701 (CX738) (Refer to Fig. 1)

Pushing any of the function buttons grounds the actuating circuit of IC701 (terminals ⑨ to ⑬) and the output from terminals ② to ⑦ controls each mode. (Output occurs when terminals ⑨ to ⑬ are at less than 4.5V.)

Fig. 1 indicates the output in each mode by a logic value.

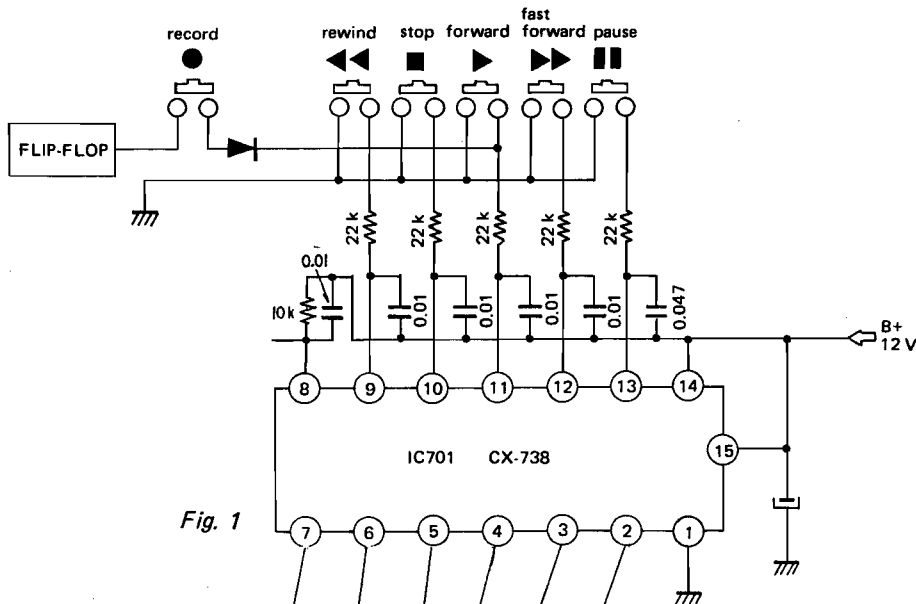

Fig. 1

Table 1

Mode \ Output	Brake	▶ <sup>D</sup> *1	▶	◀◀	▶▶	
	Brake	▶ <sup>D</sup> *1	▶	◀◀	▶▶	
STOP	0	0	0	0	0	0
Forward	1 or 0	1	1	0	0	HOLD *2
Fast Forward	1	0	0	0	1	HOLD
Forward/PAUSE	1	1	1	1	0	0
	1					1

0: 0V output

1: 12V output

HOLD: Previous mode condition does not change.

\*1. ▶<sup>D</sup> represents DELAY Forward.

\*2. If PAUSE is 0 (previous condition), Brake becomes 1.  
If PAUSE is 1 (previous condition), Brake becomes 0.

\*3. In Forward mode, if PAUSE button is pressed, the solenoid is de-energized and the brake is operated.

**2. Action when switched from Fast Forward (▶▶) or Rewind (◀◀) to Forward (▶).** (Refer to Fig. 2)

• Action of IC701

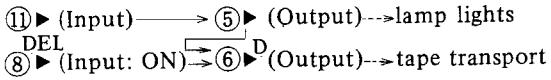

1. When switched from fast forward or rewind to forward, the output of terminal ⑤, determined by the input of terminal ⑪, puts Q719 in the ON state and the forward lamp lights.
2. Also, since the supply reel motor has been revolving at high speed, it does not stop immediately and there is an output from FG.

3. Q748 is negative-biased by the output from FG, so that it is in the OFF condition, B+ voltage is applied to terminal ⑧ and there is no output from terminal ⑥ (Path ①).

4. The revolution of the supply reel motor quickly slows down and stops. When this happens, the output from FG becomes zero, Q748 returns to the ON state. Terminal ⑧ is grounded and terminal ⑥ outputs the control signal and forward motion starts. (Once in forward, there will be no influence from terminal ⑧ until again switching to fast forward or rewind.)

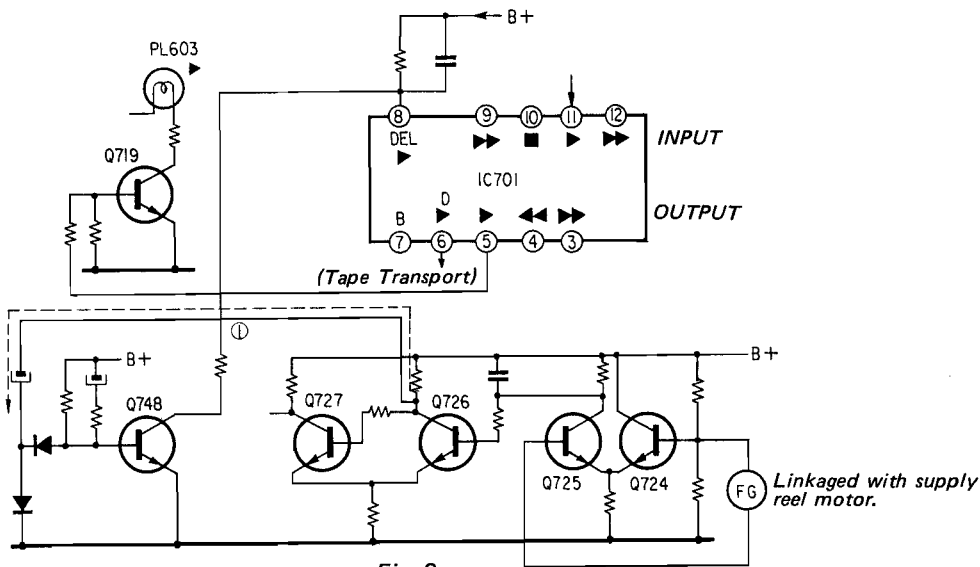

Fig. 2

**3. Power Supply Section** (Refer to Fig. 3)

The power supply section consists of the following four kinds of circuits.

1. Power supply (12V) for lamps, IC701, and solenoid hold.
2. Regulated power supply (24V) for record and playback amplifiers.

(There is a regulator in the audio amplifier section.)

3. Regulated power supply (24V: adjustment required) for headphone amplifier, bias oscillator, and system control section.
4. Power supply for solenoid initial-energization.

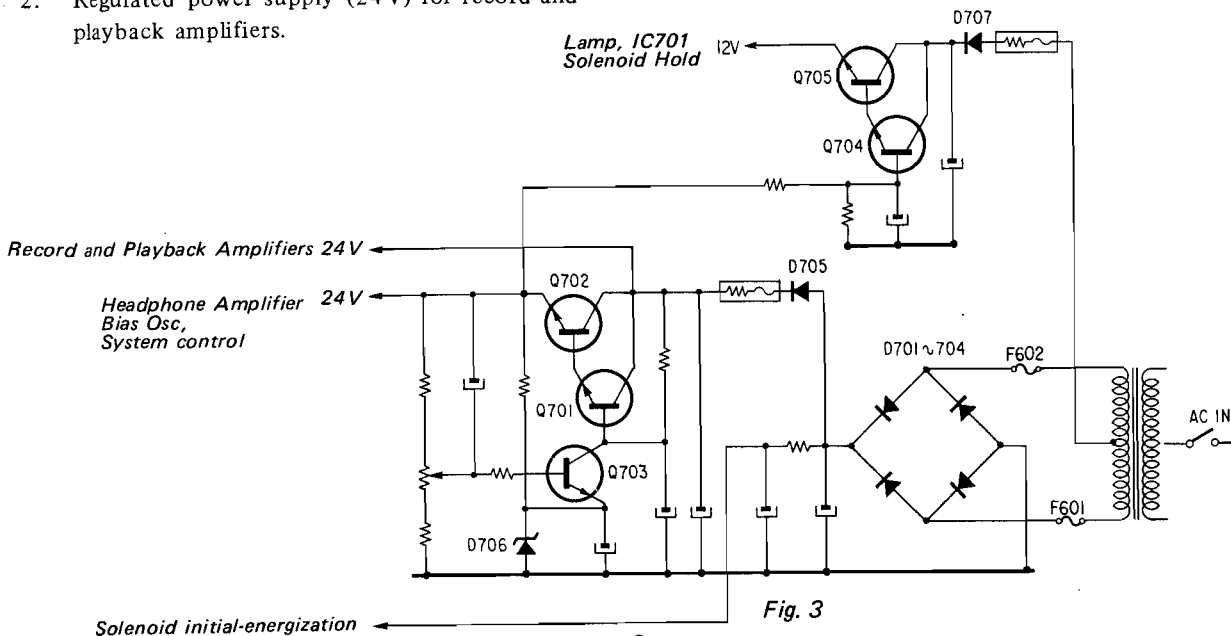

Fig. 3

## 4. High Voltage Power Supply for Solenoid Initial-Energization (Refer to Fig. 4)

The solenoids need a high voltage during pulling, but a low voltage is adequate for hold.

1. When stopped or during tape transport, Q706 is ON and Q707, 708 are in the OFF state providing a 12V power supply for solenoid hold.
2. In the hold condition, as the signal PAUSE (II) enters point A from IC701, Q718 goes to the ON state and the (+) side of C710 at +24V suddenly drops to zero potential so that the (-) side (point C) becomes -24V. Then the signal passes through R712 and D708 where it is discharged at a time constant of  $R712 \times C710$ .
3. Though Q706 was ON, as the PAUSE signal enters point A, point C becomes -24V which creates an OFF state. As a result, Q707, 708 are in the ON state and provide a high voltage power supply for solenoid initial-energization.  
(In this case, turning on playback muting. Refer to page 11.)
4. When C710 has completed discharging, Q706 goes to the ON state and Q707, 708 go to OFF. The solenoid power supply returns to +12V for hold use.

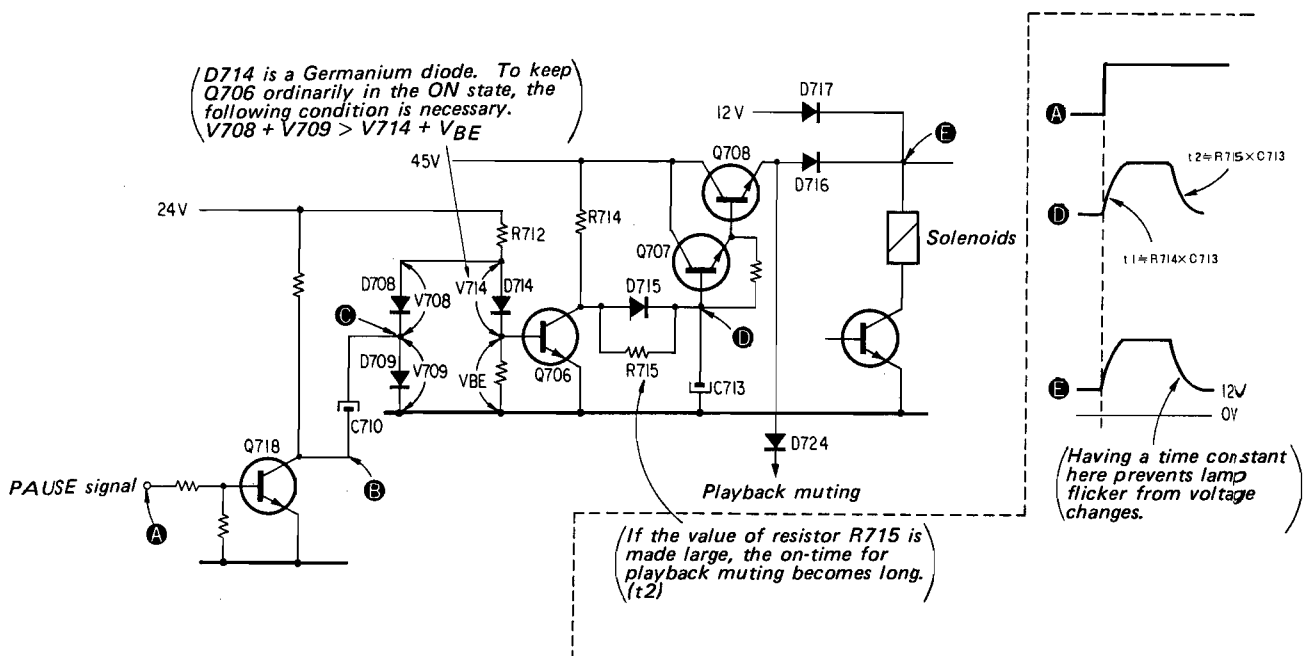

Fig. 4

**5. Reel Motor Starting Circuit (Refer to Fig. 5)**

When switching from STOP to forward or from PAUSE to forward the Reel Motor (M601, 602) cannot start up right away. (Especially true when using a 10-inch reel.)

For this reason, the torque of the Reel Motor (M601, 602) is greater at starting than during running.

1. With the IC701 output  $\triangleright^D$ , Q712 (for solenoid drive) goes ON and C740 causes Q737 to go OFF for an instant. (The operation is the same as the solenoid initial-energizing.)
2. When Q737 goes OFF, Q733 goes ON and the signal passes through R794 and D742 to add to Q736. This permits Q736 saturation and about 50V is applied to the supply reel motor (M601) for starting it. (Path ①)
3. For the take-up reel motor (M602), as Q737 turns OFF, Q738 turns ON and energizes relay (RY702) which supplies 70V from the power transformer for motor starting. (Path ②)
4. When discharge at the time constant determined by R803 and C740 is finished, Q737 returns to the ON state and Q738 turns OFF releasing the relay (RY702).
5. Q733 gradually goes OFF at the time constant determined by R792 and C735. Afterwards, the supply reel motor (M601) changes to tension-regulator operation and the take-up reel motor (M602) becomes constant-torque operation.
6. D753 grounds Q739 base bias supplied through Q733, R793 and D743 to prevent short-circuiting of the 70V and 50V of the power transformer through Q739 and the diode bridge during starting of the take-up reel motor. The reason for Q733 having a time constant prevents

tension arm vibration caused by voltage variation when the starting operation changes to the running operation.

**6. Tension Regulator Circuit**

If motor torque is uniformly constant, the back tension torque of tape transport becomes stronger as tape winding diameter becomes smaller. This causes variations in the tape speed, tape-to-head contact, level and frequency characteristics.

Hence, in order to keep tape tension constant, even when tape winding diameter changes, a tension regulator circuit (including a mechanical tension regulator) is employed to control the torque of the supply reel motor.

1. Since the tape speed is constant in the forward mode, as the amount of tape on the supply reel decreases, the revolution speed of the supply reel (frequency of FG) increases. In other words, FG generates the signal of frequency in inverse proportion to the radius of the remaining tape.
2. By rectifying the signal, dc voltage in inverse proportion to the radius of the remaining tape is obtained.
3. If the supply reel motor torque is constant, tape tension at the supply reel exit will be in inverse proportion to the tape amount. In other words, to maintain constant tape tension a motor torque which is proportional to the tape amount is the best.
4. Hence, by using the dc voltage obtained in 2., constant tape tension is achieved.

(Please refer to the next page for tension set-up and circuit operation.)

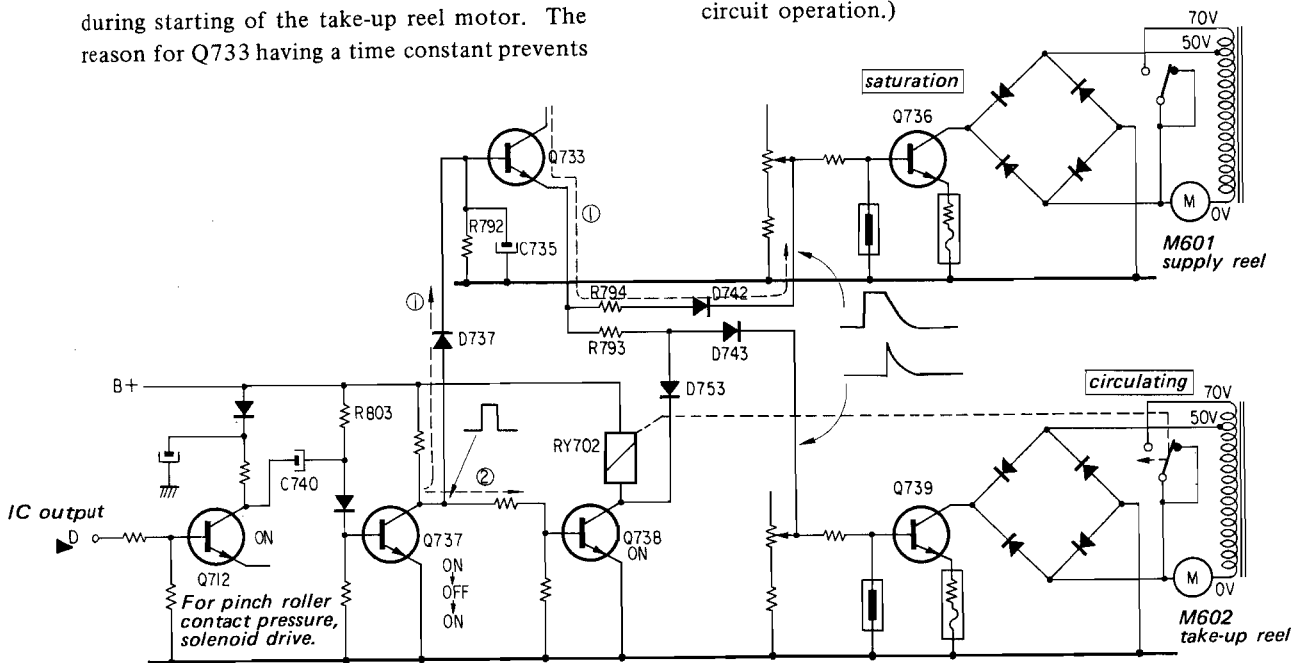

## 7. Tape Tension Set-up and Circuit Operation

(Refer to Figs. 6, 7)

In order to make tape tension constant, torque at the start of tape winding (slow revolution) must be increased and torque near the end of tape winding (fast revolution) must be decreased.

1. At a slow revolution speed, the pulse interval is long so that the dc voltage output ⑨ becomes high; hence supply reel motor torque becomes large.

2. At a fast revolution speed, the pulse interval is short so that the DC voltage output becomes low making the supply reel motor torque small.
3. Even if the tape speed is varied, if the radius of the remaining tape is the same, the back tension has to be the same. Therefore, when changing from 19 cm/s (7½ ips) to 38 cm/s (15 ips) with switch (S602-1), Q730 is turned ON and half cycle of the input signal to switching transistor (Q731) is turned OFF to produce the specified torque.

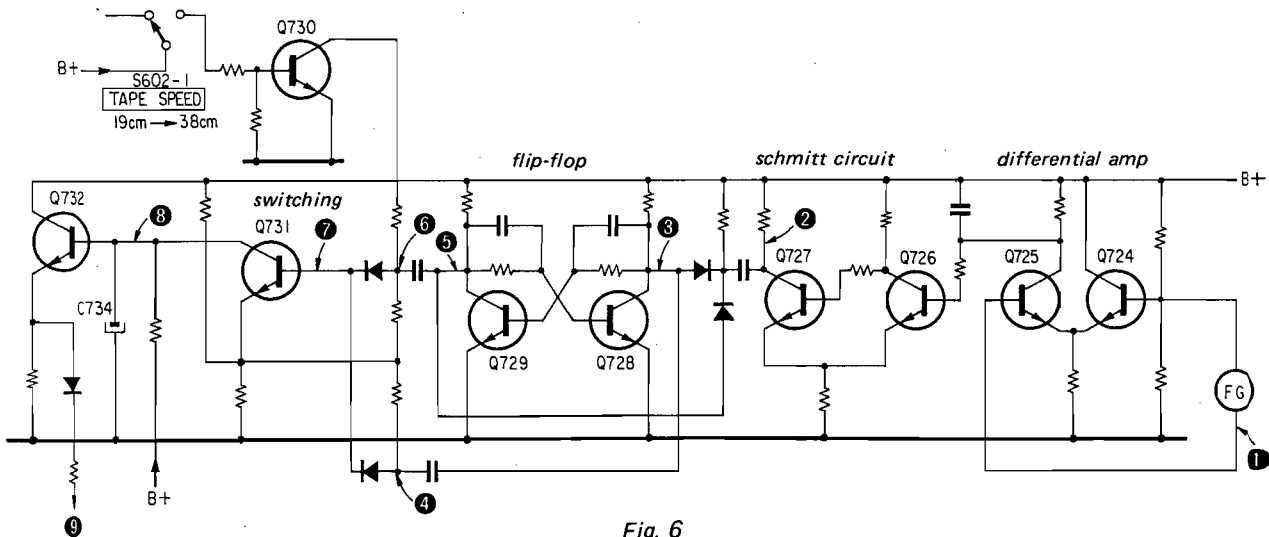

Fig. 6

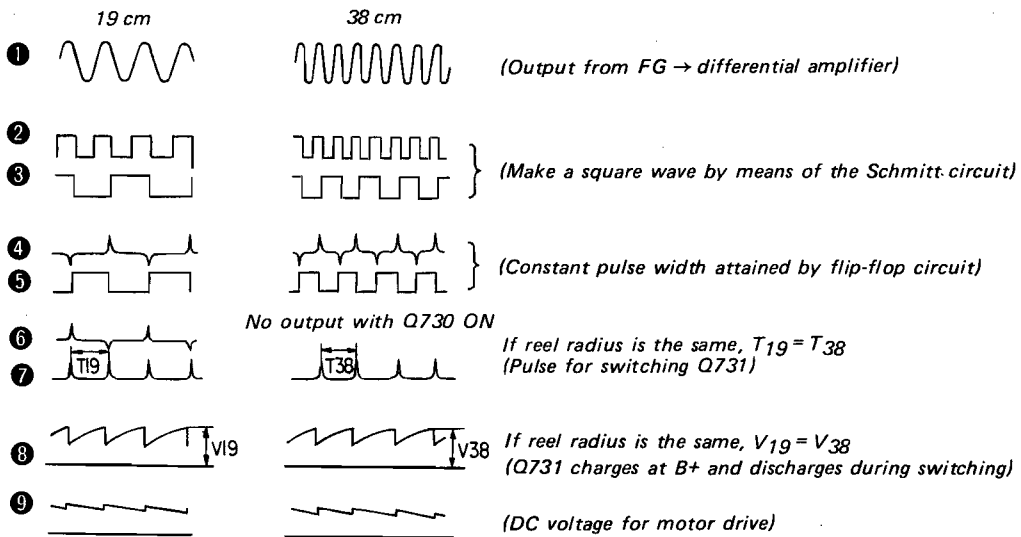

Fig. 7



**8. Mechanical Tension Regulator**

(Refer to Figs. 8, 9)

(Tension value at the tension arm part.)

In tape transport, the tension arm mechanically regulates the tape tension. In this section the tension arm is explained.

- As the radius of the tape amount on the supply reel changes, also changes resulting in tension value variation.  
(The tension arm itself moves, but this is not considered in this explanation. Also, the tape contact at the tape guide is constant meaning no change in the tension value.)
- The relationship between the tension value (TA) at the entry point of the tension arm and the back tension (TB) is as shown in Fig. 9. Thus from the end of a 7-inch reel tape to the start of a 10-inch reel tape the mechanical tension will be about 1.3 (experimental value) times the variation that occurs.
- If such mechanical tension is used, a tension relative to the radius of the tape amount is obtained and the tape tension is regulated. With only this change, however, back tension will not be sufficient.

That is why this tape recorder uses both a tension regulator circuit and a mechanical tension regulator to produce the proper constant back tension.

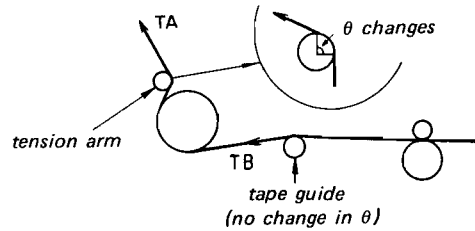

Fig. 8.

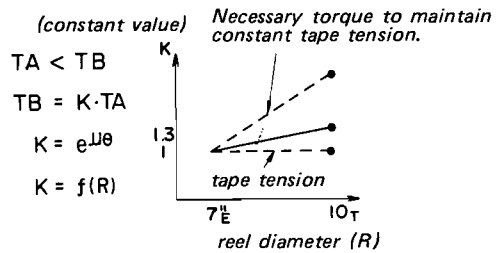

Fig. 9

**9. Reel Motor Drive Circuit**

(Refer to Figs. 10, 11)

The take-up reel motor operates under constant torque and the supply reel motor is controlled by a tension regulator circuit. Reel motors are driven in the following way.

- As the base current of the drive transistor is changed, the impedance between the collector and the emitter varies and the voltage supplied to the motor varies to change the motor torque. By utilizing this relationship, the motor torque can be controlled. (Refer to Fig. 10)
- The characteristics of this drive transistor are indicated in Fig. 11. The variation of collector current  $I_C$  relative to collector-emitter voltage  $V_{CE}$  is not sinusoidal, but produces a square wave that causes unnecessary vibration in the motor.
- Therefore, a bridge rectifier circuit is used to supply full-wave-rectified current to the base of the drive transistor and raise base current  $I_B$  making collector current  $I_C$  closer to a sine wave to drive the motor.

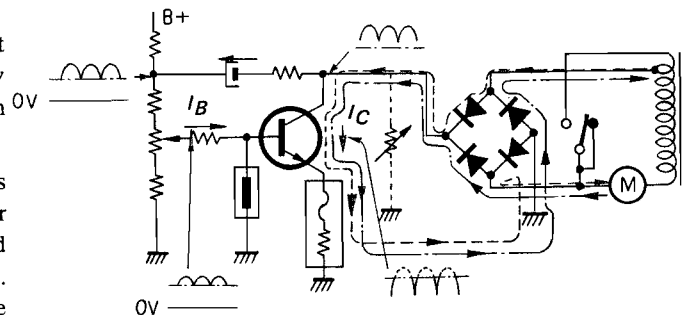

Fig. 10



Fig. 11

**10. Back Tension Set-up in Rewind Mode**

(Refer to Fig. 12)

When adjusting (RV703) and setting up forward take-up tension, rewind back tension is automatically decided. (fixed)

In addition, as determined by reel size, the switching of impedance (R) as seen from the drive transistor (Q739) side takes place.

1. The set-up of R for each mode is shown in Table 2.

**Table 2**

S601	FWD	REW
10½	∞	R603//(R604 + R605)
7	R605	R603//R605

2. The values for R603, 604 and 605 are determined to obtain the desired rewind back tension in the situation where the forward take-up tension is adjusted (RV703).

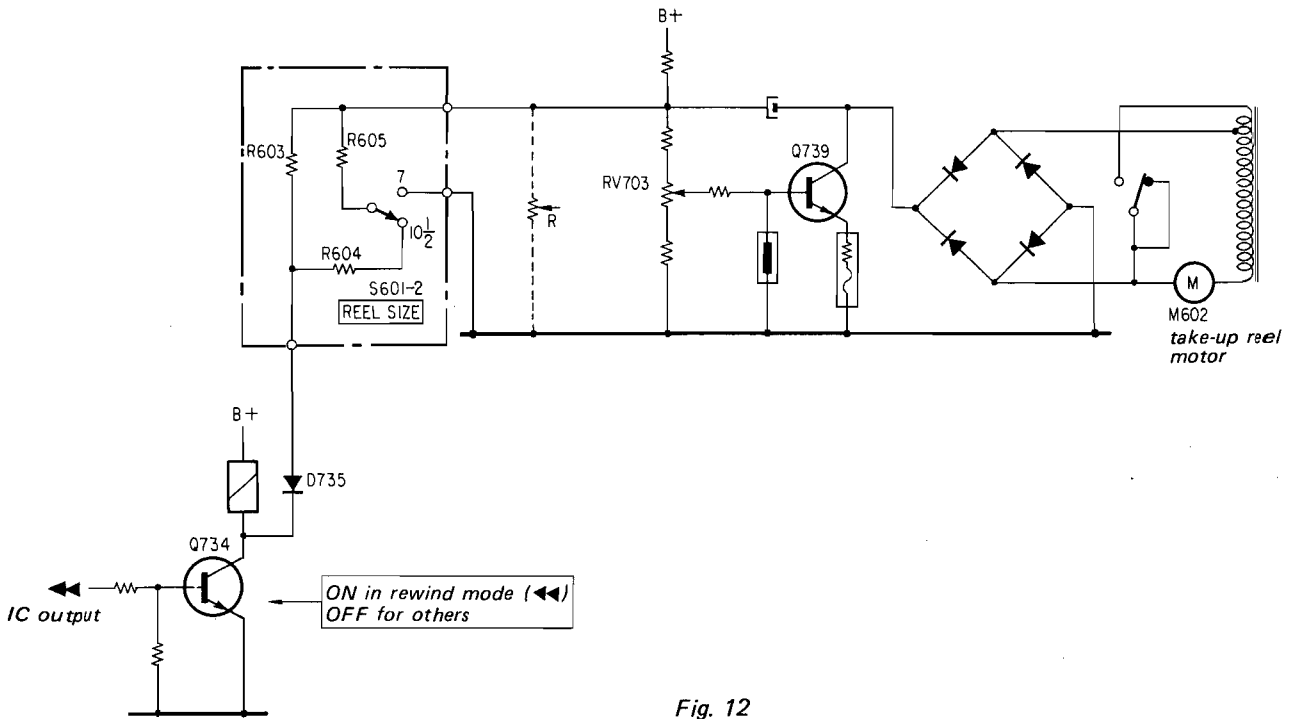

**Fig. 12**

**11. Back Tension Set-up in the Fast Forward Mode**  
(Refer to Fig. 13)

When adjusting (RV702) and setting up the forward back tension, the fast forward back tension is automatically decided. (fixed)

1. The fast forward (▶▶) output from IC701 passes through D740 and R791 and is added to the base of Q735. (path ①)

• Q735 base voltage becomes

$$\left( \begin{array}{l} \text{IC Output} \\ \text{(▶▶)} \\ \text{about 12V} \end{array} \right) \times \frac{R601 \text{ (R602)}}{R791 + R601 \text{ (R602)}} \text{ (V)}$$

( ): For 7-inch reel.

2. In addition, this output is passed through R601 (R602) connected to REEL SIZE selecting switch (S601-1) and then grounded through D734 and Q720. (Path ②)
3. The values for R791, R601 and R602 are determined to obtain the desired fast forward back tension in the situation where the forward back tension is adjusted.

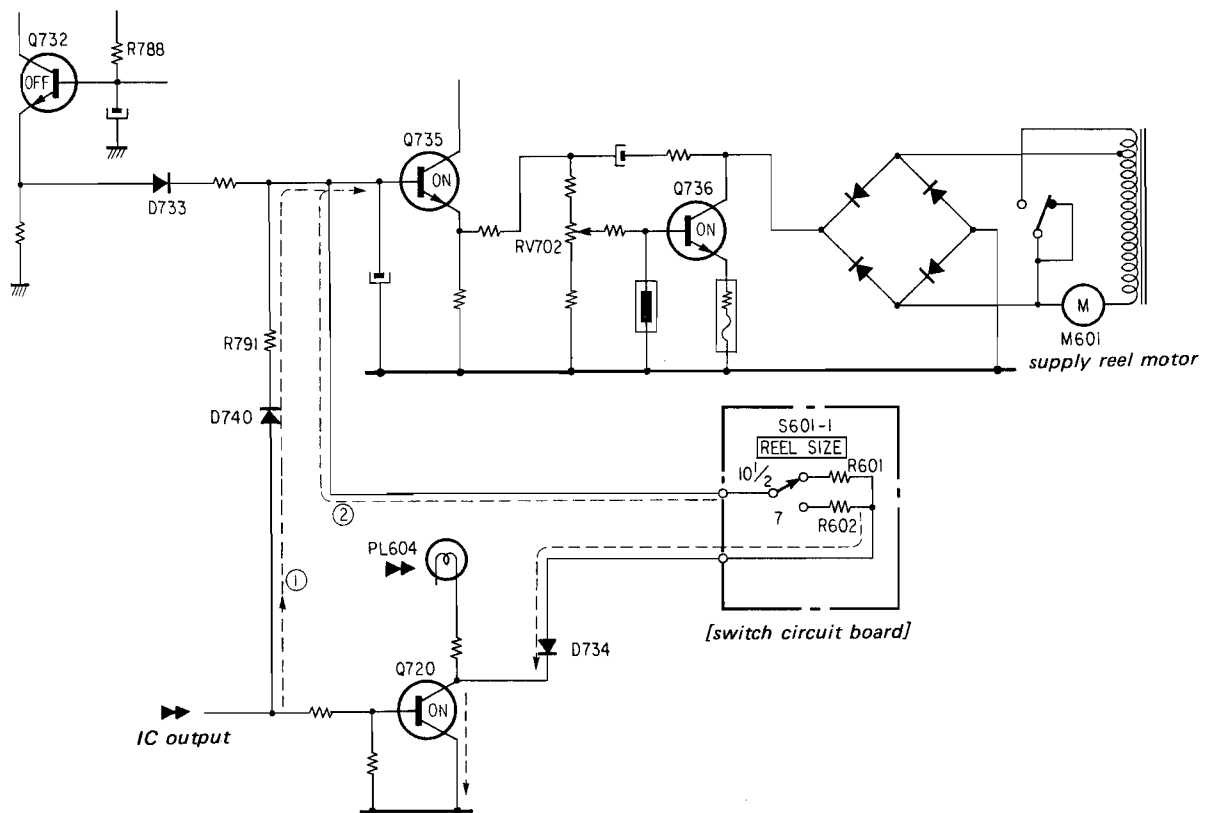

Fig. 13

**12. STOP Circuit (Refer to Fig. 14)**  
**(Shut-Off Circuit)**

1. When the tape has finished winding, or when slack, tension arm micro-switch (S605, 606) is closed adding 24V to Q723 through R756. (Path ①)
  2. Because of this, Q723 is turned ON activating the IC701 input.
  3. When AC is ON, Q722 slowly goes to the ON state as determined by time constant of R751 and C717. (Refer to TIMER-activated operation)
- To supplement this, while Q722 is OFF, Q723 is ON and the STOP input of IC701 is activated. (Path ②)

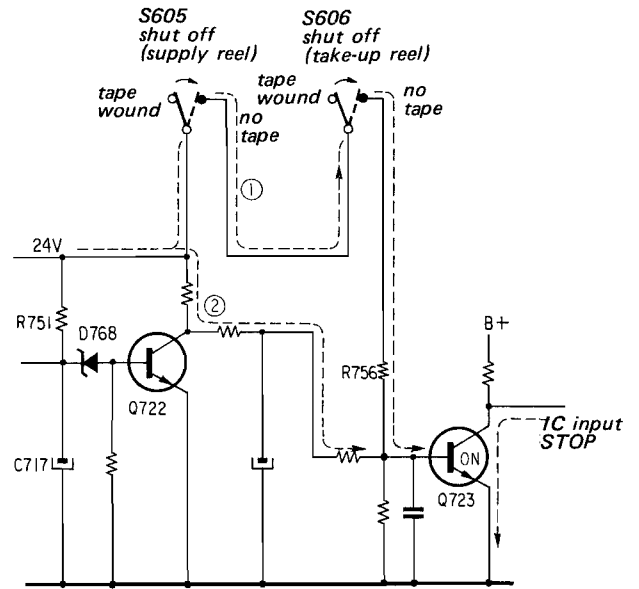

Fig. 14

**13. TIMER-Activated Operation (Refer to Fig. 15)**

1. With TIMER switch (S603) ON, when the POWER switch (S604) is turned on, the voltage at point A supplied through D726 and B+ voltage (+24V) rise after 0.2 to 0.5 seconds.
2. At this time, C717 is charged through R751 and the charged voltage turns on zener diode D768 after 5 seconds determined by a time constant of R751 and C717, and then turns on Q722.
3. As a result of 2., the (+) side of C719 becomes -5 to -6V and passing through S603, D766 and 767 are turned ON to produce the record and forward signals for the Record or Playback modes.

(The circuit containing D726, 727, C716 and R750 makes C717 quickly discharged, when the power supply is turned off.)

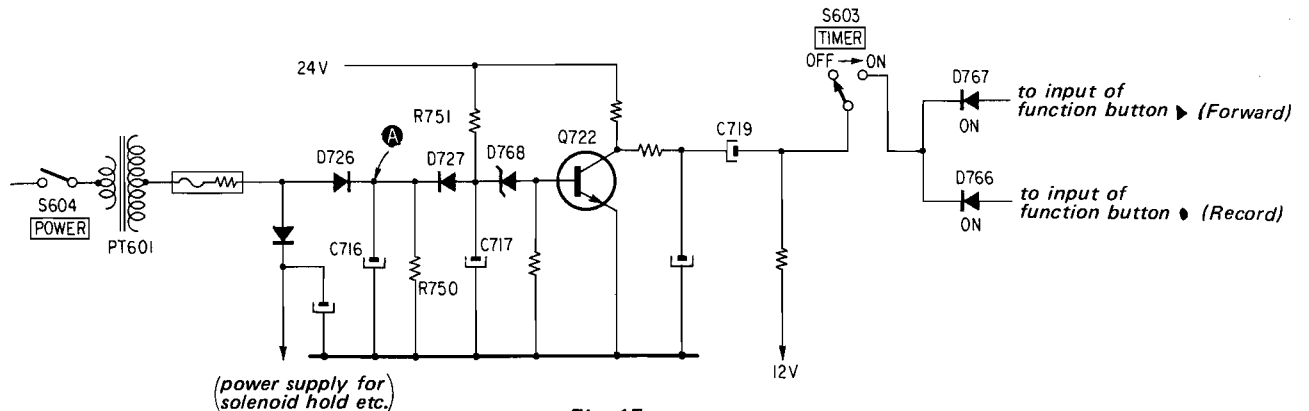

Fig. 15

14. Playback Muting (Refer to Fig. 16)

During the solenoid initial-energization period, playback muting is operated for click sound prevention, but depending on the switching mode, the muting time is changed. (Path ①)

(According to time constant of R712 and C710-712 on the solenoid initial-energization circuit.)

- forward (▶) → PAUSE (⏸) : about 0.4 seconds
- STOP (■) → forward (▶) : about 0.2 seconds
- PAUSE (⏸) → forward (▶) : about 0.2 seconds

Muting time at the switching period from forward mode to PAUSE mode is longer than other switching period. This is to prevent noise caused by slight movement of tape when tension arm moves at the time just changed into PAUSE mode.

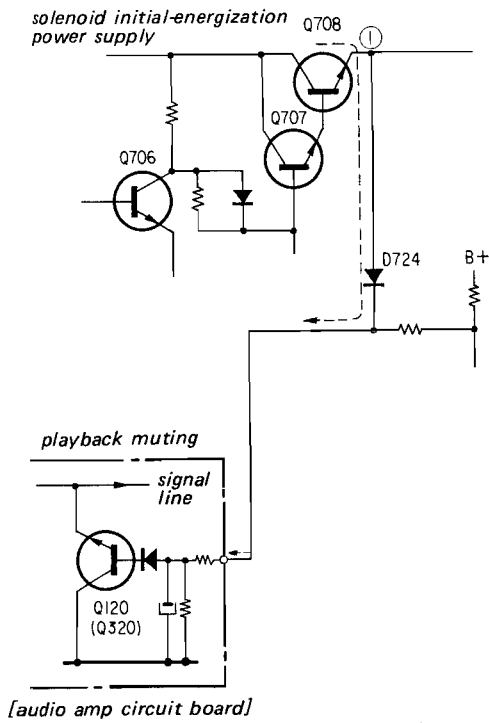

Fig. 16

**15. Record Muting (Refer to Fig. 17)**

Record muting is operated by turning Q106 (Q306) of the audio amp circuit ON.

1. In playback mode, the record mode switch S103 (S303) adds B+ to Q103 (Q303) turning it ON and record muting is operated. (Path ①)
2. In the situation where the Record and Forward buttons are not pressed, with the REC MODE switch set to the record position, Q744 of the flip-flop circuit is OFF and B+ through D759 turns ON Q741, which turns ON Q106 (Q306) to activate record muting. (Path ②)
3. When the record and forward buttons are pressed and remote control RM-30 is used, when record muting switch is ON, B+ turns ON Q741 through D760, which turns ON Q106 (Q306) to activate record muting. (Path ③)

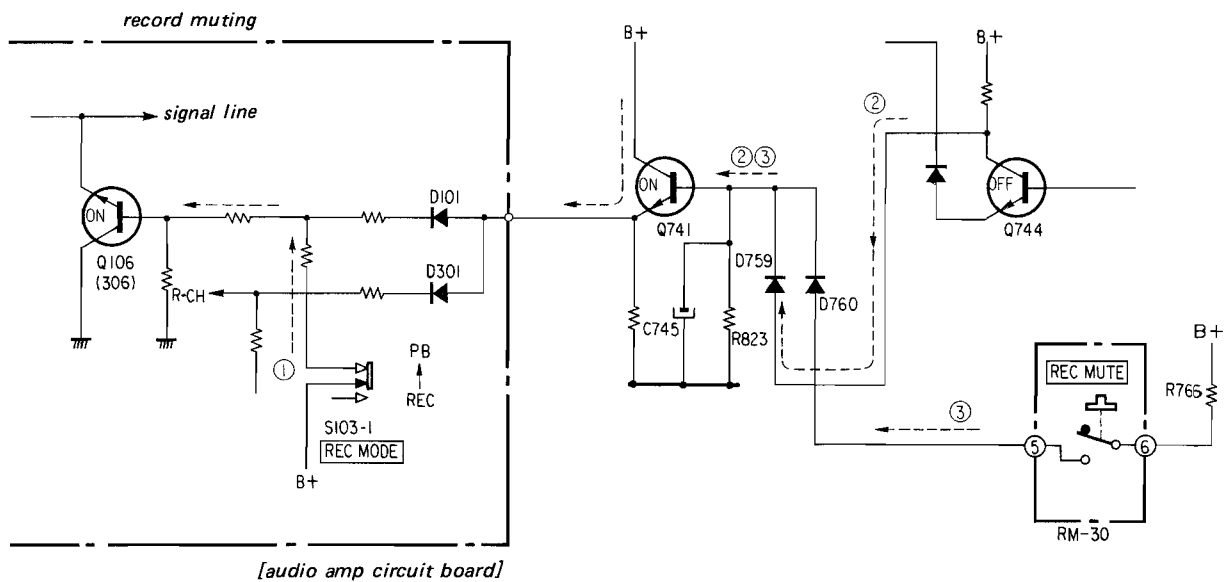

Fig. 17

**16. REC MONITOR MUTE Circuit**  
(Refer to Fig. 18)  
(ON and OFF for LINE OUT)

The REC MONITOR MUTE switch (S607), located on the rear panel, is turned ON to prevent howling during recording.

1. This circuit, by turning OFF Q507 of the Audio Amp section, cuts off the LINE OUT signal.
2. During ordinary operation, Q740 is OFF because Q722 is ON.
3. With the REC MONITOR MUTE switch (S607) set to the OFF position, B+ turns ON Q507 through S607, which activates relay (RY501) and the LINE OUT signal comes out. (Path ①)
4. Also, in playback (Q744 is OFF) mode, B+ goes through the TAPE side of the MONITOR switch (S104-2) to turn ON Q507 and the LINE OUT signal comes out. (Path ②)  
(When S104-2 is set to the SOURCE position, or when in record mode Q744 turns ON not to supply B+, this circuit is cut off.)

5. With S607 ON, the signal comes out from LINE OUT only when the MONITOR switch is set to the TAPE position in playback mode.

With the MONITOR switch set to TAPE position, when POWER switch is turned ON, LINE OUT signal is muted to prevent a click noise. That is because Q722 is not turned ON for the period determined by the time constant of the Q722 base circuit. In this period Q740 turns ON and accordingly Q507 turns OFF to cut off LINE OUT circuit. Since Q744 also turns OFF, B+ voltage through MONITOR switch S104-2 coming from Q744 collector is ground through D769 and Q740 to prevent B+ from applying to the Q507 base. (Path ③)

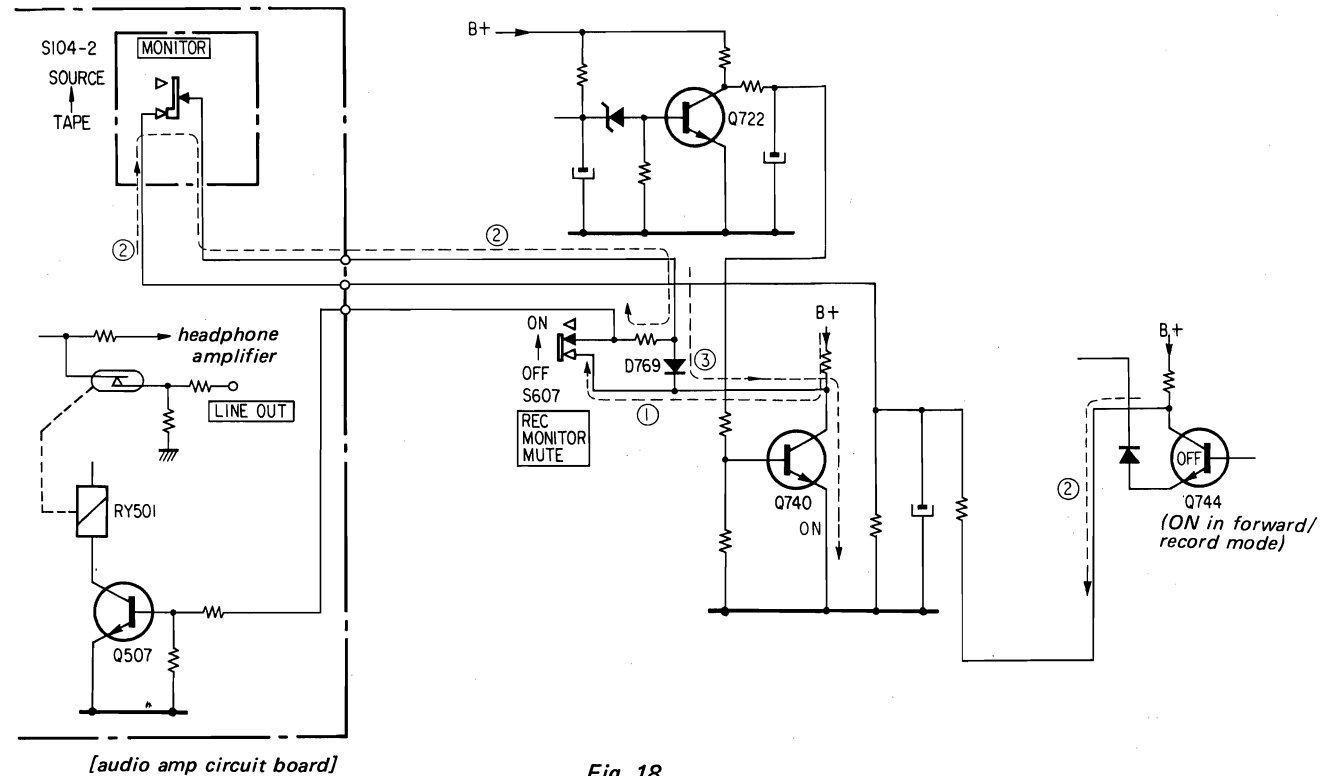

Fig. 18

**17. Power Supply for Record Bias Oscillator**  
(Refer to Fig. 19)

1. When the REC MODE switch (S103-1 or S303-1) is set to REC position, B+ is supplied to the bias oscillator circuit. (Path ①)
2. By pushing the record (●) and forward (▶) buttons, the base of Q745 is grounded. (Path ②)
3. In FWD mode, Q719 turns ON and the emitter of Q744 is grounded. (Path ③)
4. By 3., the flip-flop circuit consisting of Q744, 745 becomes ON for Q744 and OFF for Q745.
5. The non-stable multivibrator circuit, consisting of Q746, 747, repeatedly turns ON and OFF the REC lamp (PL601) due to the difference in collector load resistance.
6. With Q744 in the ON state, the Q747 base is grounded through D762, Q744, D761 and Q719. Q747 turns OFF and Q746 ON in the stable condition and the lamp stops turning on and off and lights up continuously. (Paths ④ and ⑤)
7. With Q744 in the ON state, Q741 goes to OFF and REC muting is released.
8. In forward operation, Q743 turns ON and Q744 ON, Q742 turns OFF, which supplies B+ to the bias oscillator circuit and the bias oscillator circuit operates. (Path ⑥)

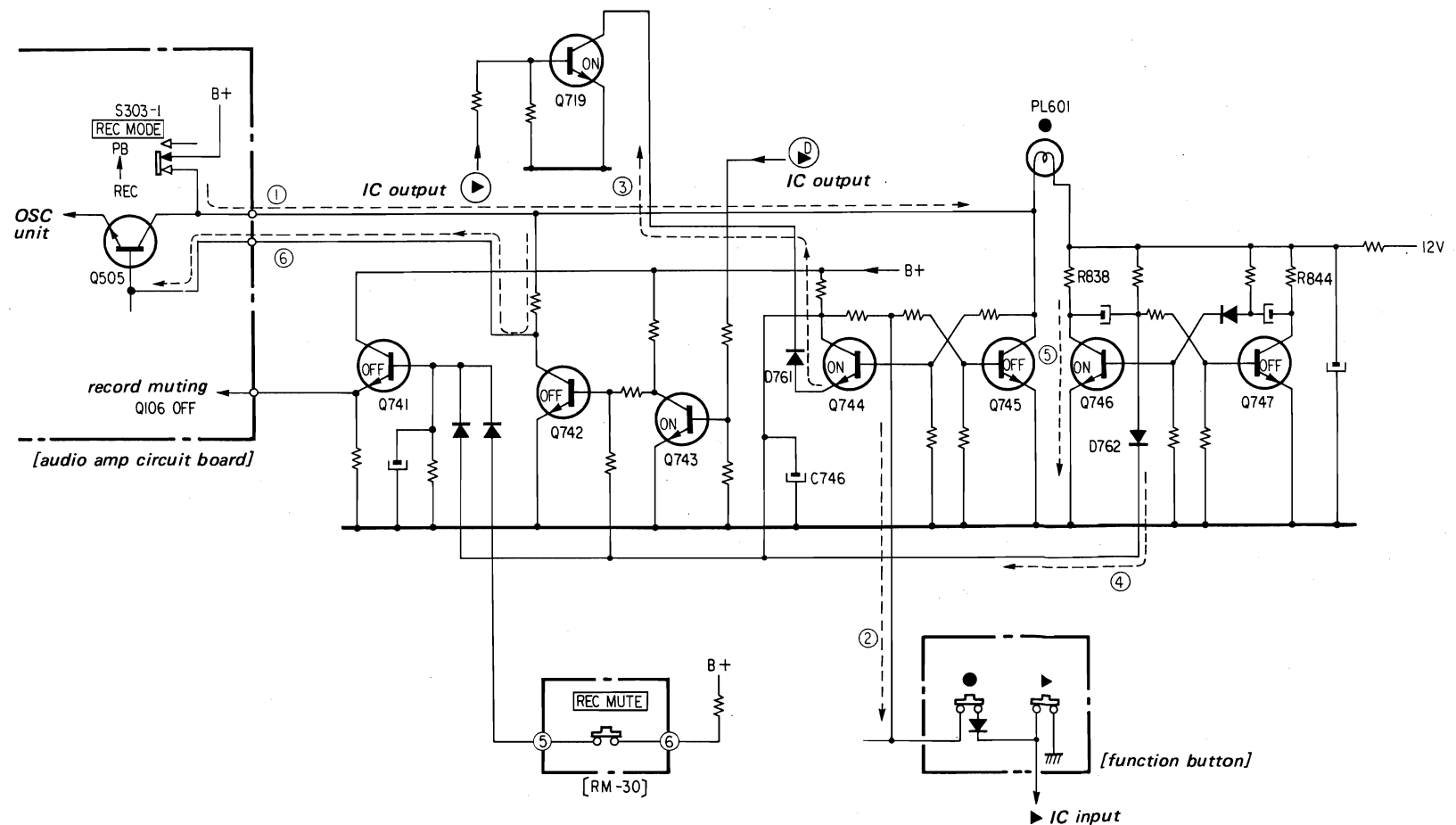
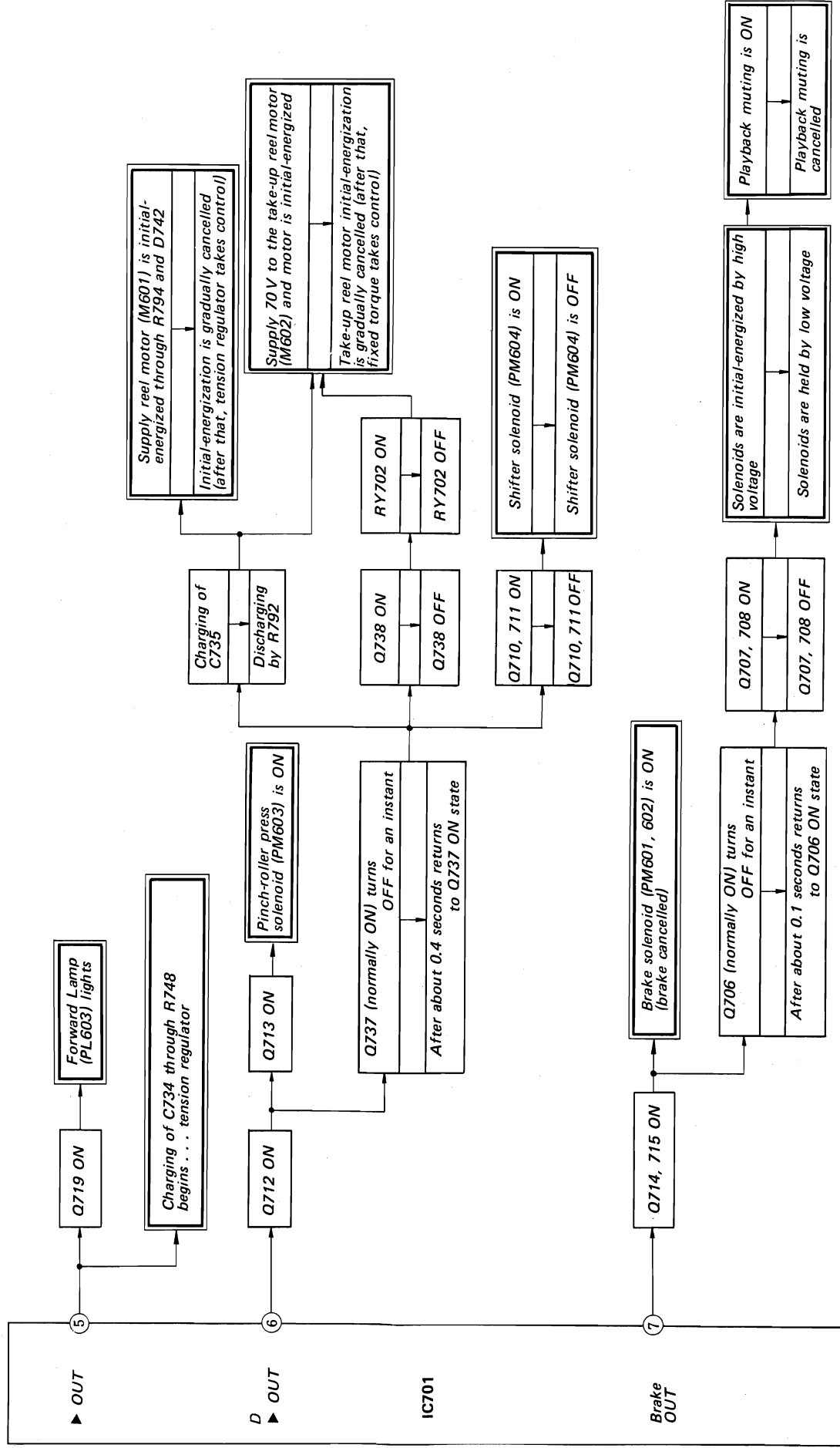

Fig. 19

18. Function Button Action Flow Chart

[Function Button Action Flow Chart 1]

- STOP (■) → Forward (▶)
- Forward/PAUSE (■, ▶) → Forward (▶)
- □: indicates final action



[Function Button Action Flow Chart 2]

- Forward (▶) → Forward/PAUSE (■, ▶)
- □: indicates final action

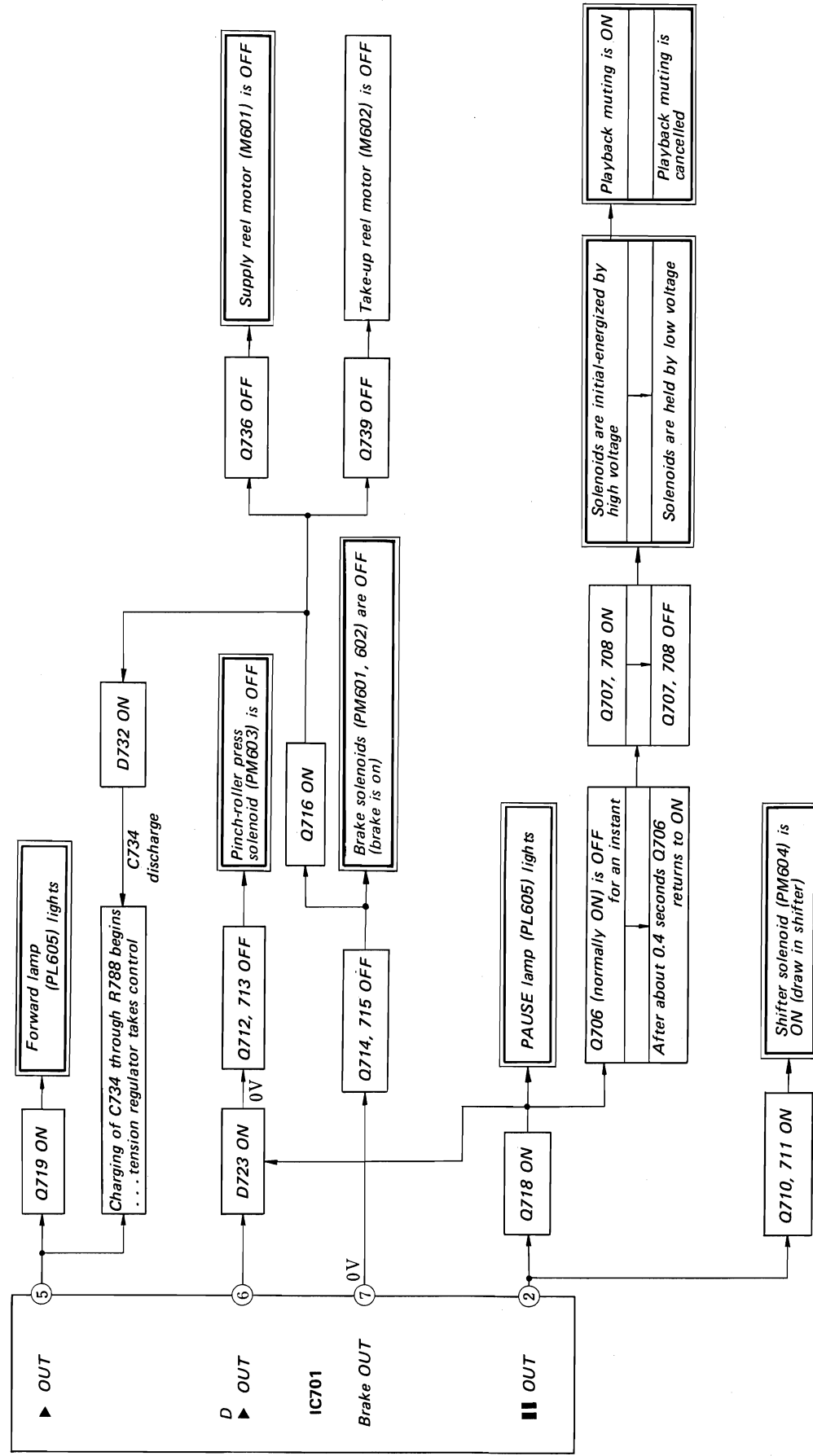



[Function Button Action Flow Chart 3]

- Record/Forward (●, ▶)
- Record/Forward/PAUSE (●, ▶, ||)
- □: indicates final action

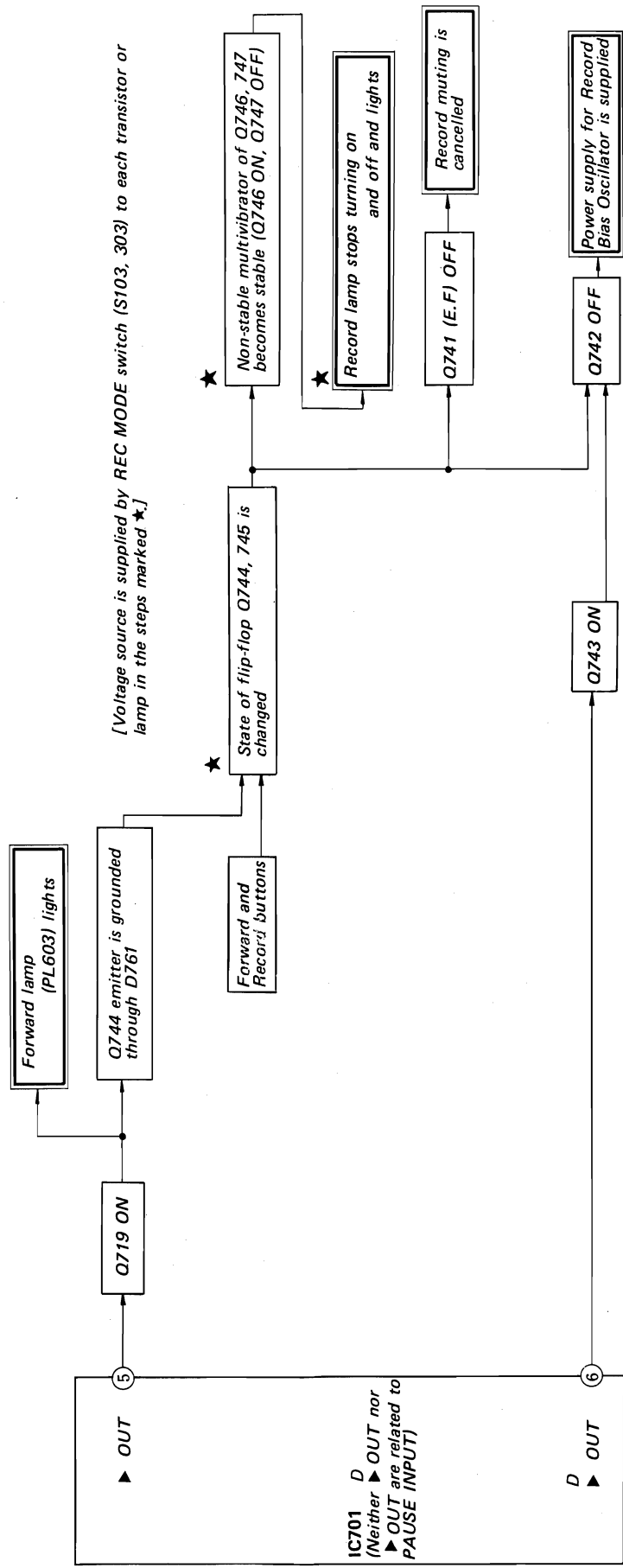

TC-766-2 TC-766-2

Forward mode and Record mode

- [ ] : final action
- - - - - and [ ] : temporary action

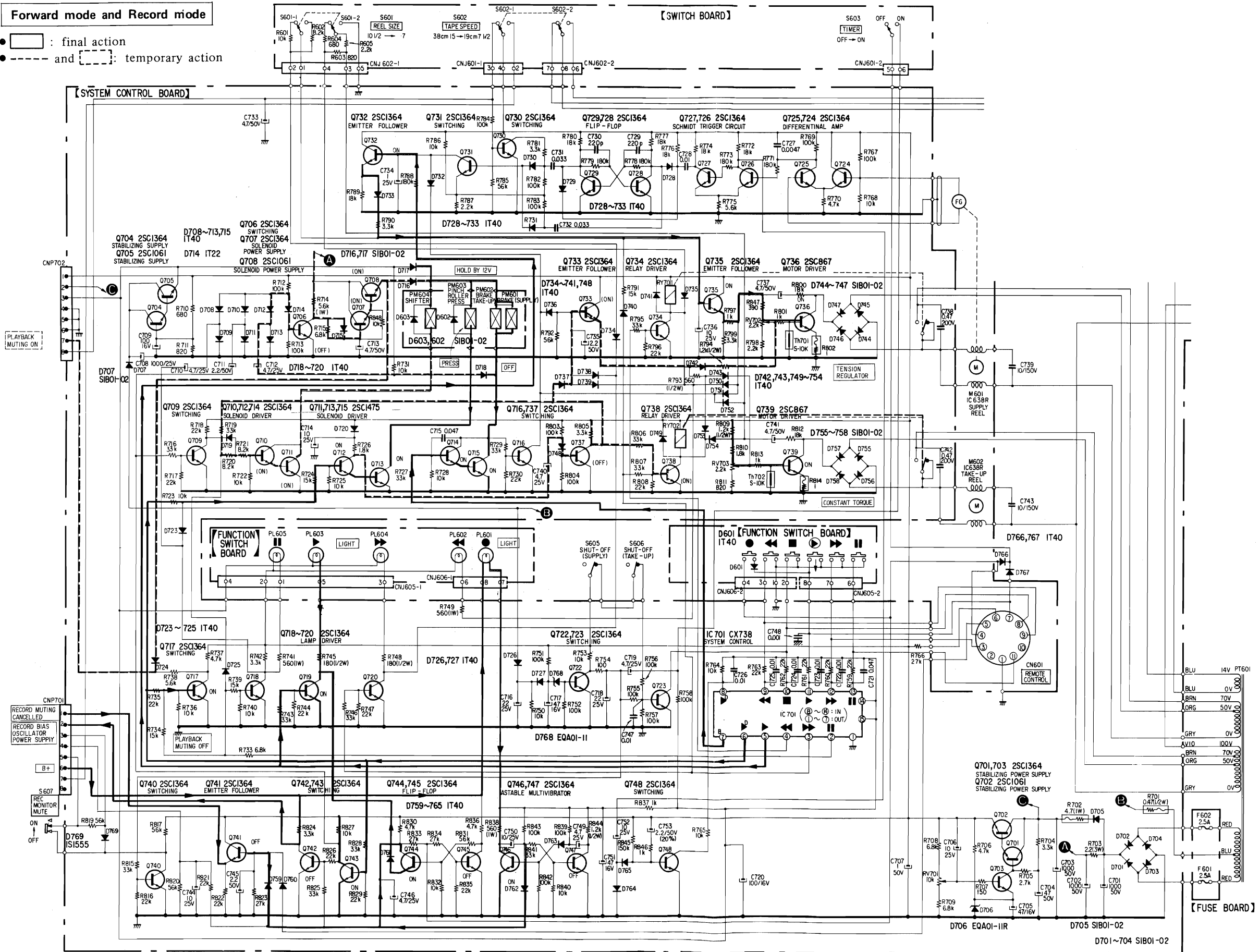

# TC-766-2 TC-766-2

**PAUSE mode**

- : final action
- and  : temporary action

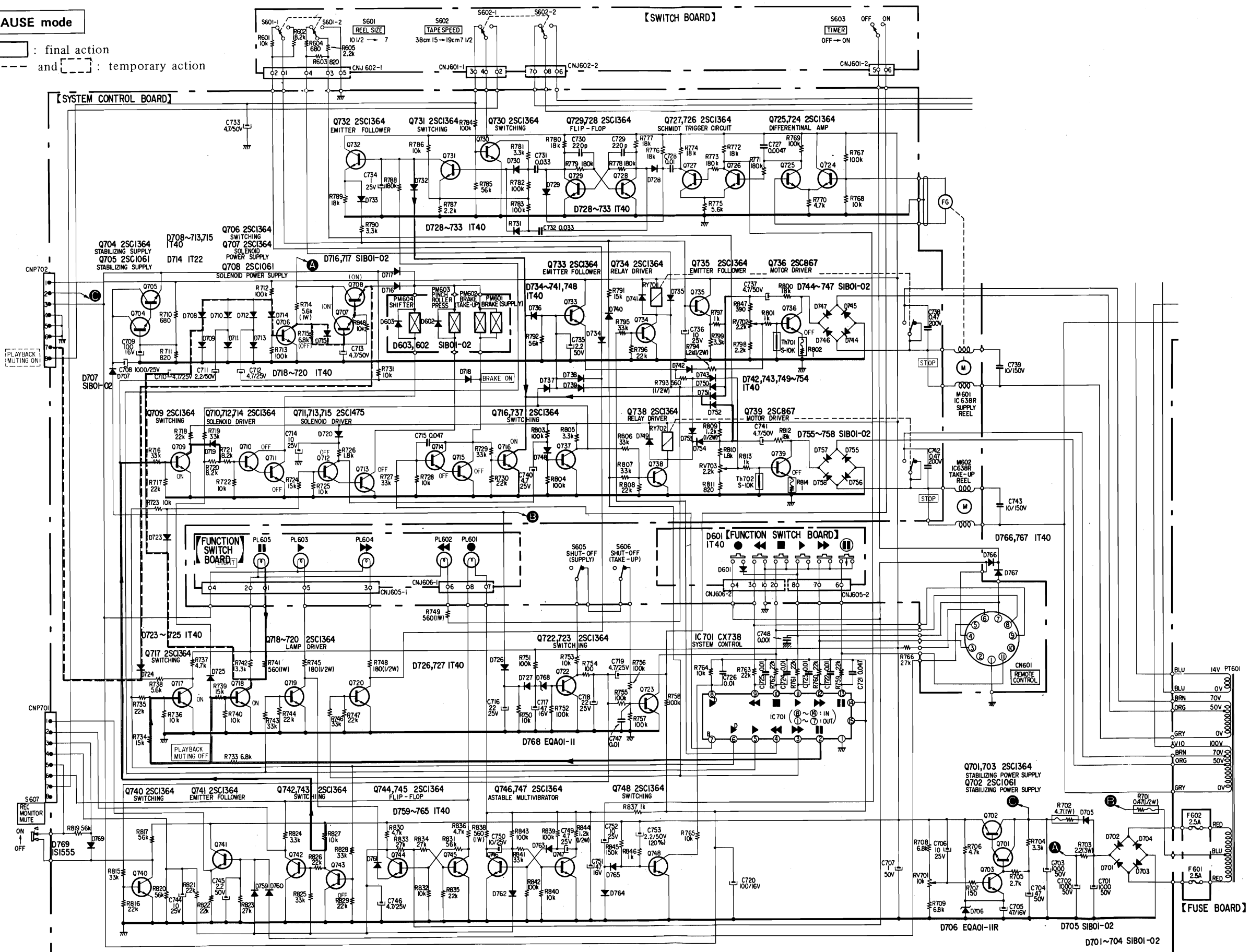

# TC-766-2 TC-766-2

**Fast Forward mode**

- : final action
- and  : temporary action

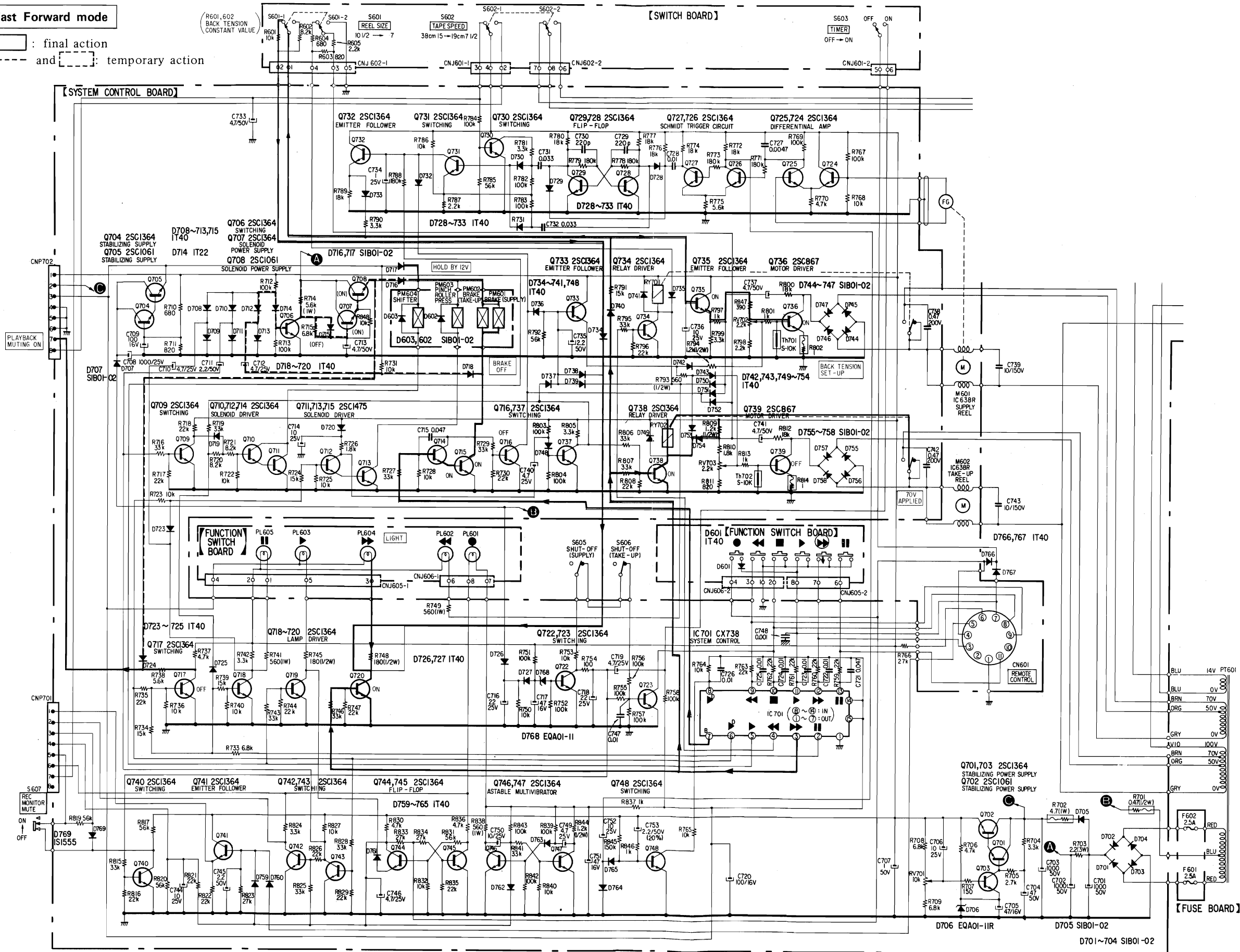

# TC-766-2 TC-766-2

**Rewind mode**

- : final action
- - - - and    : temporary action

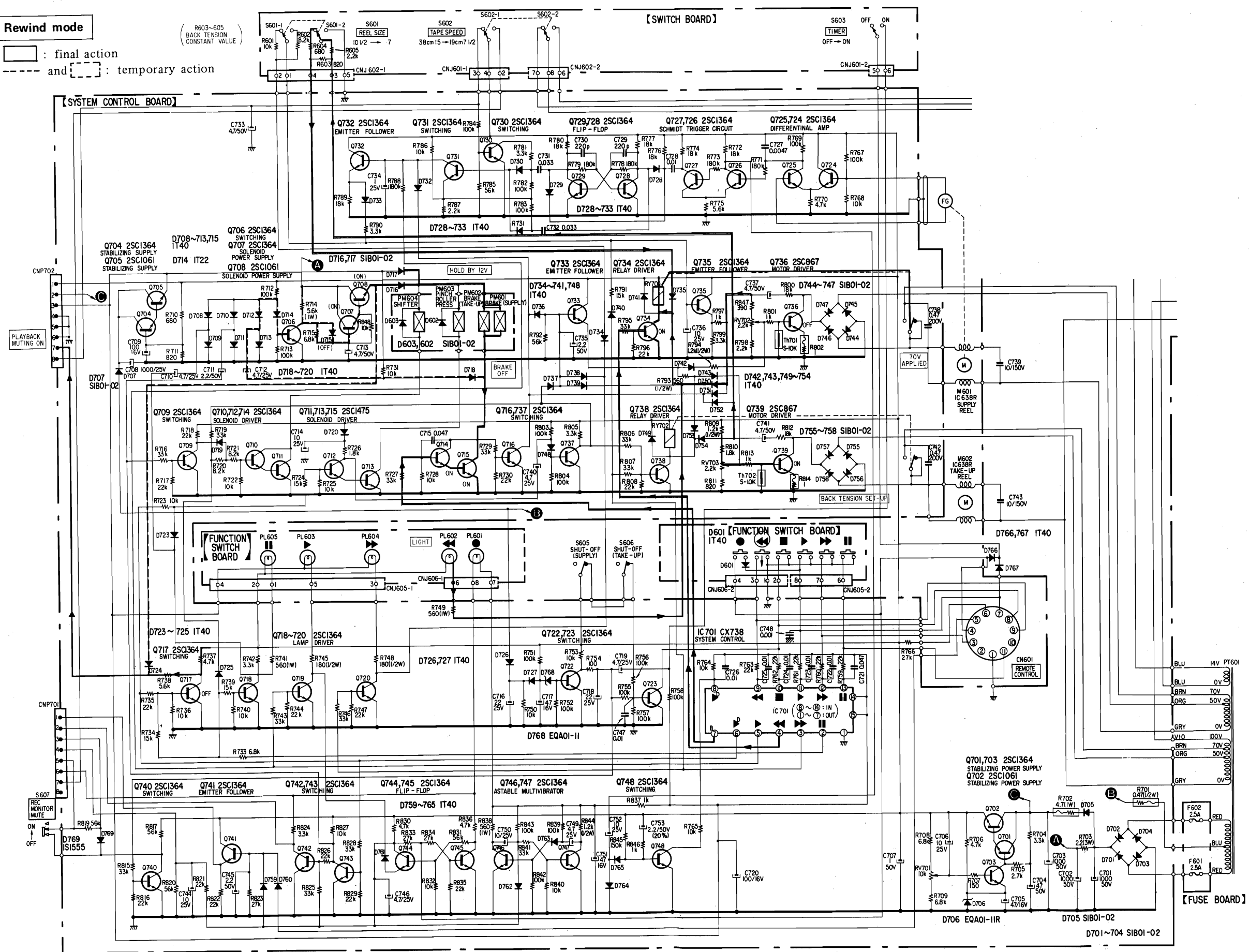

TC-766-2 TC-766-2

20. Function Button Action Time Chart

