

TC-880-2

*US Model
Canadian Model
E Model
UK Model*



This complete service manual contains TC-880-2 PART 1, therefore discard your TC-880-2 PART 1.

STEREO TAPECORDER

SPECIFICATIONS

Power Requirements:

Model	Voltage	Frequency
USA	120 V ac	50/60 Hz
Canada	120 V ac	50/60 Hz
E	100, 110, 120, 127, 220, 240 V ac	50/60 Hz
UK	110, 127, 220, 240 V ac	50/60 Hz

Power Consumption:

Model	Watt
USA	135
Canada	135
E	120
UK	120

Track System:

record	2-track 2-channel stereo/monaural
playback	2-track 2-channel stereo/monaural 4-track 2-channel stereo

Tape Speed: 38 cm/sec (15 ips)
19 cm/sec (7½ ips)

Recording Time: With 1,100 m (3,600 ft) tape,
26.7 cm (10½ inch) reel
Stereo recording
approx. 45 min. at 38 cm/sec (15 ips)
approx. 90 min. at 19 cm/sec (7½ ips)
Mono recording
approx. 180 min. at 19 cm/sec (7½ ips)

Fast Winding Time: With 740 m (2,400 ft) tape,
26.7 cm (10½ inch) reel
approx. 2 min. 30 sec.

Reels: 26.7 cm (10½ inch) or smaller

Drive System: Direct drive

Bias Frequency: 160 kHz

Equalization: NAB standard

S/N Ratio: 65 dB with SONY ferri-chrome tape
62 dB with SONY SLH-180 tape
59 dB with standard tape

Harmonic Distortion: 0.5 %

Crosstalk at 1 kHz: 55 dB

Frequency Response: According to NAB standard

Tape	Tape Speed	
	19 cm/sec (7½ ips)	38 cm/sec (15 ips)
SONY standard	25~20,000Hz ± 2dB	25~30,000Hz ± 2dB
SONY SLH	25~25,000Hz ± 2dB	25~35,000Hz ± 2dB
SONY ferri-chrome	30~30,000Hz ± 2dB	20~40,000Hz ± 2dB

Wow and Flutter: According to NAB standard
0.02 % at 38 cm/sec (15 ips), WRMS
0.03 % at 19 cm/sec (7½ ips), WRMS
According to DIN standard
± 0.03 % at 38 cm/sec (15 ips)
± 0.04 % at 19 cm/sec (7½ ips)

Inputs: MIC IN
(phone jack) . . . 2
(connector, XLR-3-13) . . . 2 (E, UK Model)
(connector, XLR-3-14) . . . 2 (USA, Canada Model)
Sensitivity 0.2 mV (-72 dB)
Accept low impedance mics.
LINE IN (phono jack) 2
Sensitivity 0.06 V (-22 dB)
Impedance 100 kΩ

SONY®

SERVICE MANUAL

TC-880-2

Outputs: LINE OUT (phono jack) 2
 Output level 0.435 V (−5 dB) at load impedance of 100 kΩ with the PB ATT and FINE controls set to the reference level position.
 Suitable load impedance higher than 10 kΩ
 HEADPHONE (phone jack) 1
 Accept 8 Ω stereo headphones.
 Furnished with a level control.

Dimensions: 465 (w) x 515 (h) x 265 (d) mm
 13³/₈ (w) x 20³/₈ (h) x 10¹/₂ (d) inches
 Including projecting parts and controls.
Weight: Approx. 36.5 kg (80 lb 6 oz)
 Optical Peak Program Meter (at peak mode)
Frequency Response: 30 ~ 30,000 Hz +⁰/_{−3} dB
Response Range: −40 dB ~ +15 dB (0 dB=0.435 V)
Response Time: 1 millisecond at PEAK mode

Accessory AC Outlet: Unswitched 1 (300 W maximum)
 (Except for UK Model)

IDENTIFICATION OF SET

Identify TC-880-2 model by checking the specification label shown below.

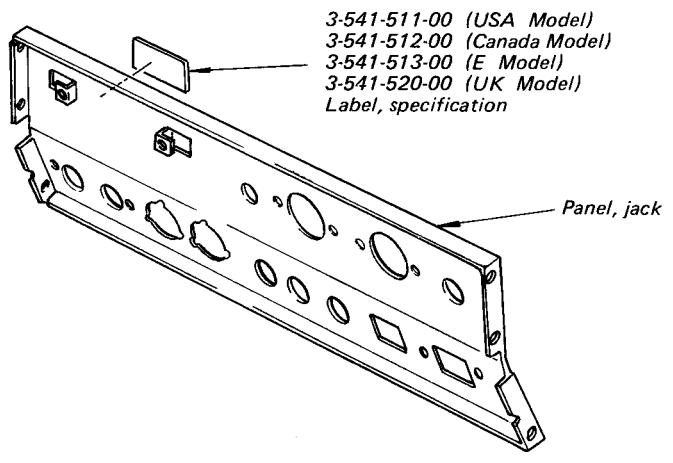

(USA Model)

SONY [®]	
TAPECORDER TC-880-2	
AC 120V	60 Hz 135W
NO. <input style="width: 100%;" type="text"/>	
MADE IN JAPAN	
○○○○○○○○○○ <input style="width: 100%; height: 20px;" type="text"/> ○○○○○○○○○○	

(Canada Model)

SONY [®]	
TAPECORDER TC-880-2	
AC 120V	60 Hz 135W
NO. <input style="width: 60%;" type="text"/> MADE IN JAPAN	
○○○○○○○○○○ ○○○○○○○○○○○○○○○○○○○○ ○○○○○○○○○○○○○○○○○○○○	

(E Model)

SONY [®]	
TAPECORDER TC-880-2	
AC 100.110.120.127.220.240V 50/60Hz 120W	
NO. <input style="width: 100%;" type="text"/>	
MADE IN JAPAN	

(UK Model)

SONY [®]	
TAPECORDER TC-880-2	
110.127.220.240V ~ 50/60Hz 120W	
NO. <input style="width: 100%;" type="text"/>	
MADE IN JAPAN	

SERVICING NOTE

1. SERVICING NOTE

When taking the capstan-motor-support bracket off, hold the shafts of the capstan motor and the flywheel. These shafts are supported by this bracket.

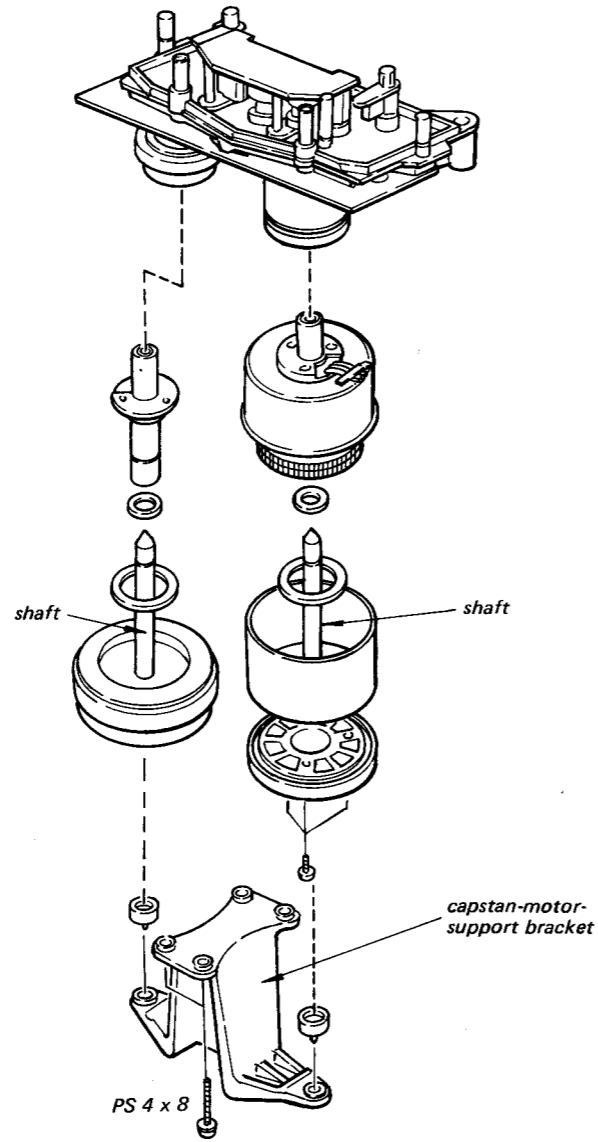

2.

When the power transistors Q1201 ~ Q1208 in the rear are exposed, please take precaution that the lugs attached to the collectors do not bend and touch the heat sink especially while serving with the set lying horizontally.

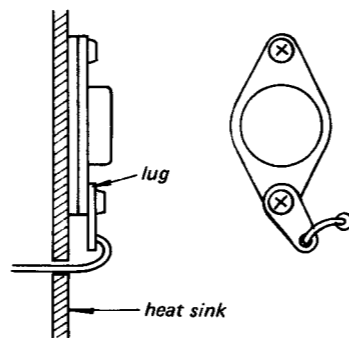

SECTION 1
BLOCK DIAGRAM

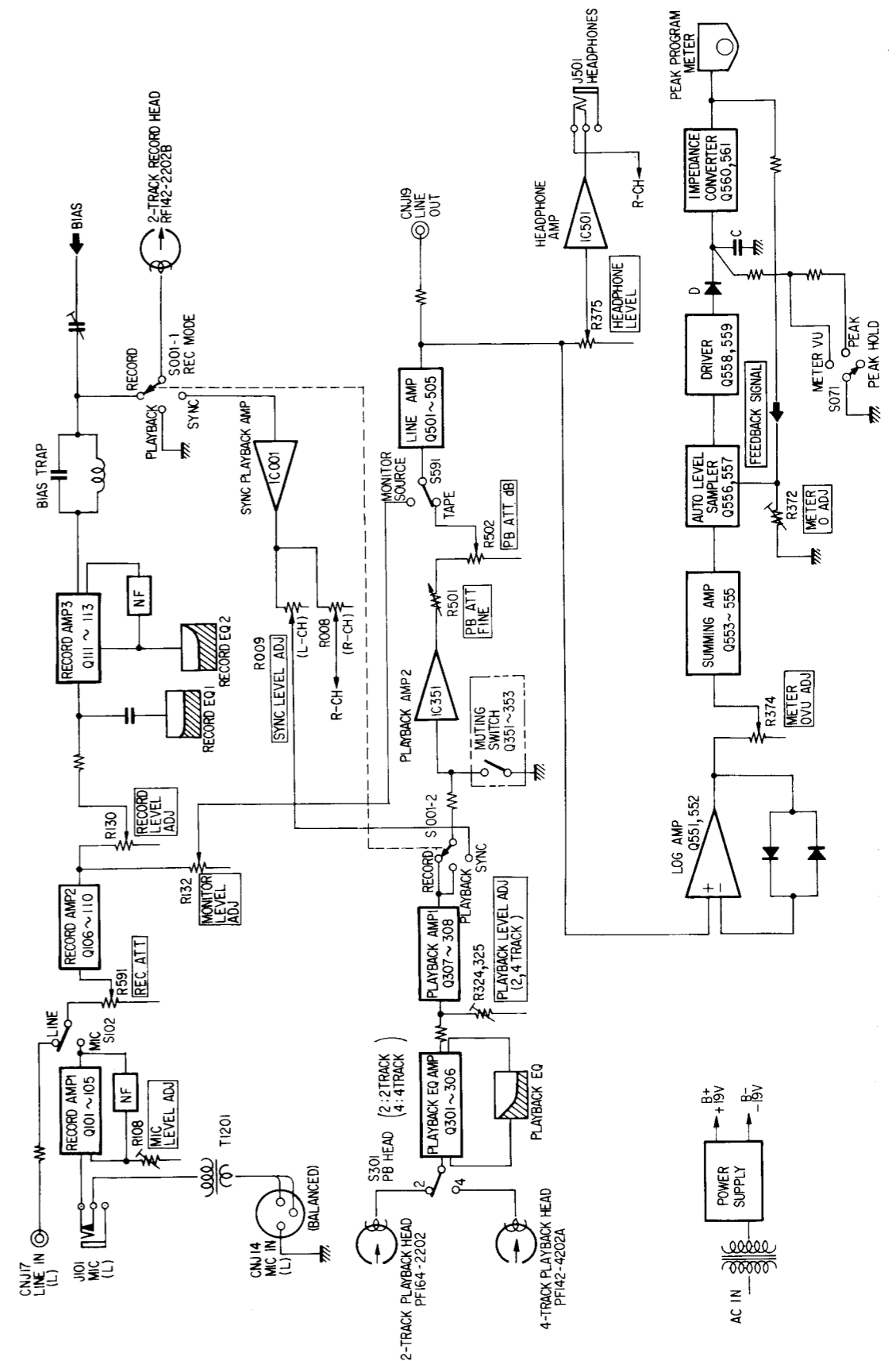

SECTION 2

REMOVAL AND CHASSIS LAYOUT

2-1. REMOVAL

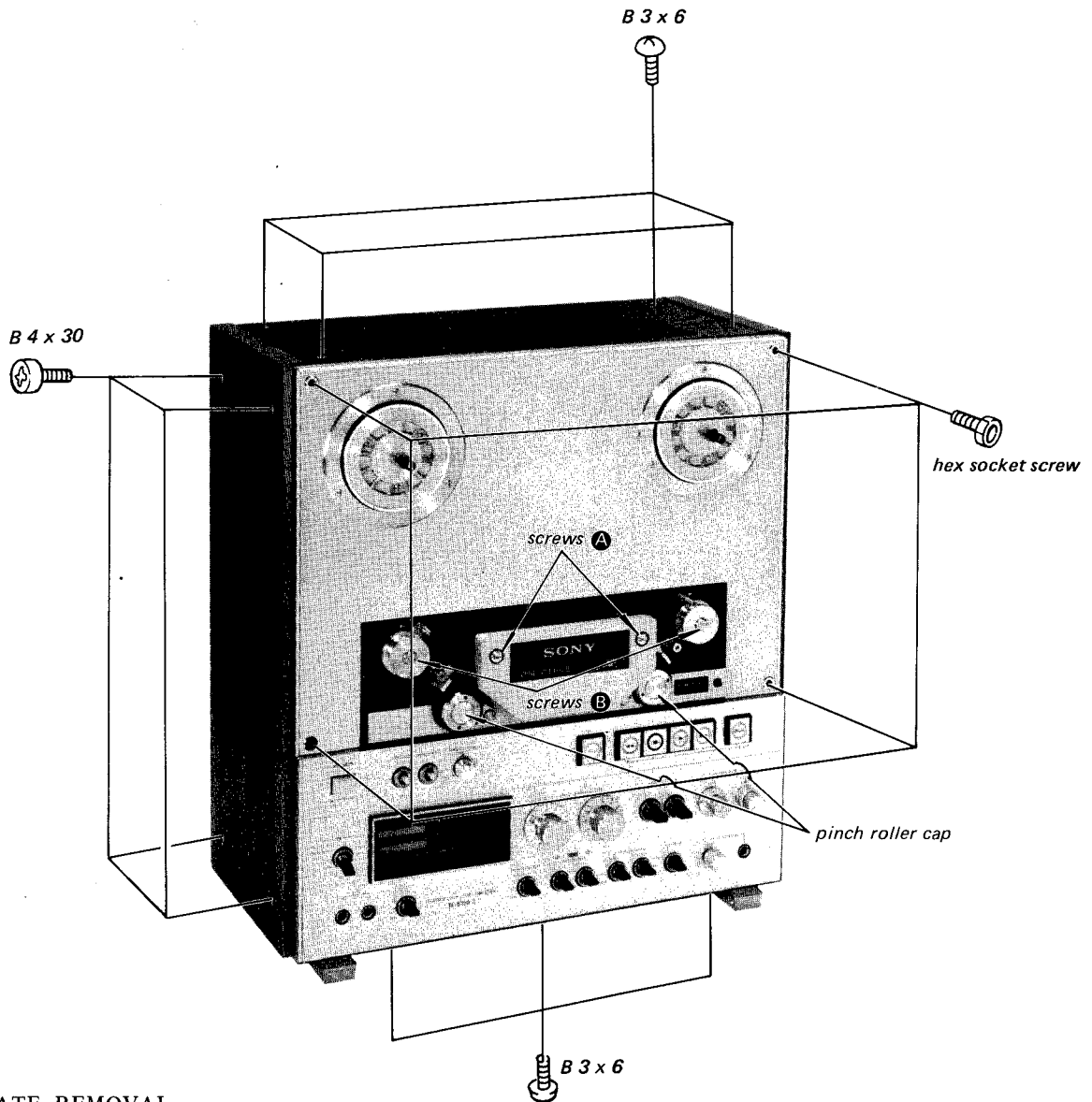

Fig. 2-1.

- **REAR PLATE REMOVAL**

----- Refer to the exploded view (1).

Remove four screws (PS 4 x 8) fixing two feet on the lower case, and remove five screws (B 4 x 8) and five washers from the rear plate.

Note: Do not remove four screws (B 3 x 6) fixing the ventilation plate on the rear plate.

- **HEAD COVER REMOVAL**

Remove two screws **A** shown above.

- **GUIDE ROLLER REMOVAL**

Remove two screws **B** shown above.

- **PINCH ROLLER CAP REMOVAL**

Turn the pinch roller caps shown above fully clockwise.

2-2. CHASSIS LAYOUT

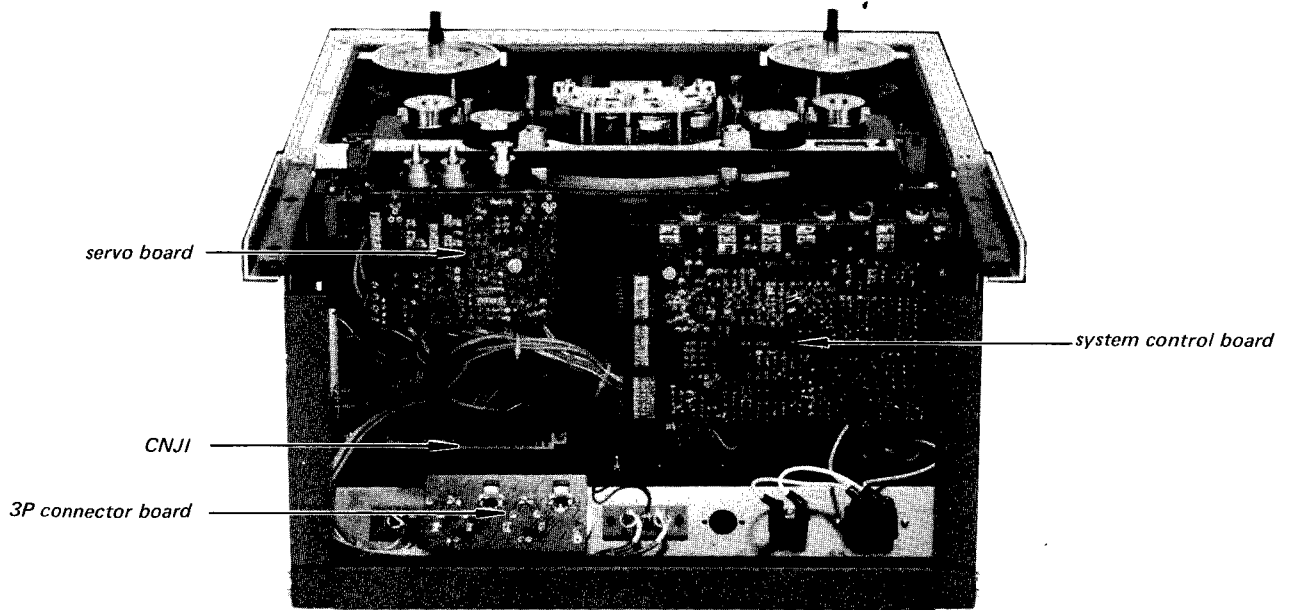

Fig. 2-2.

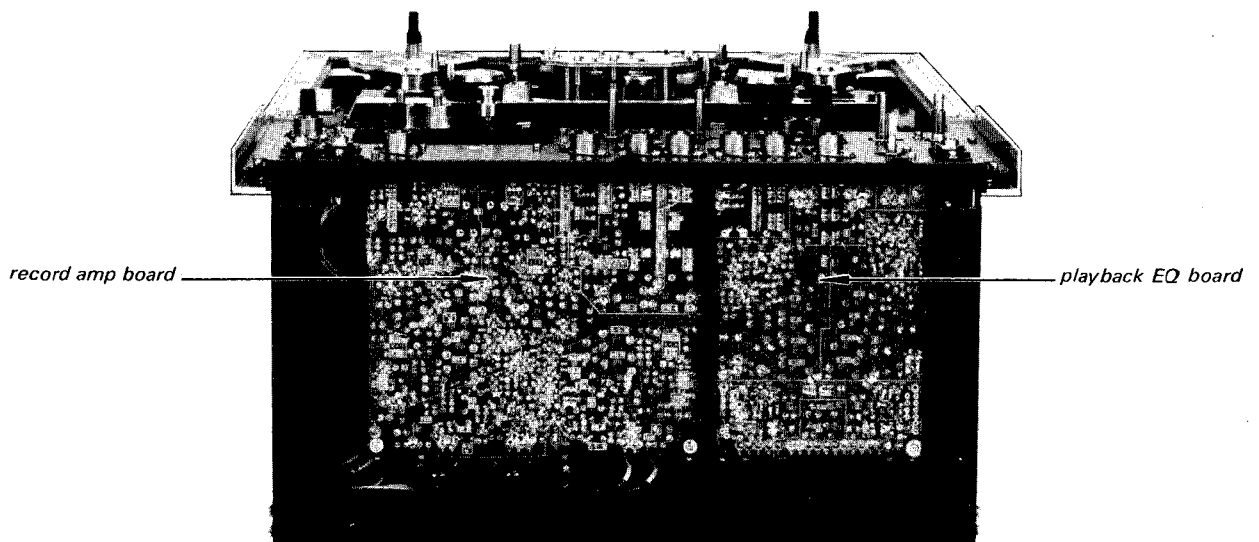

Fig. 2-3.

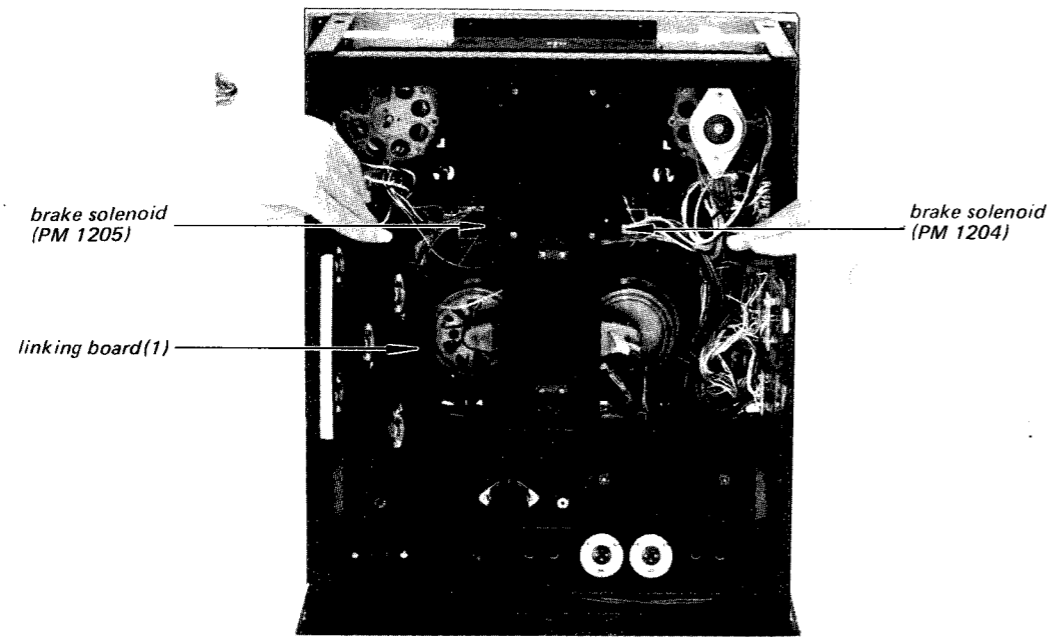

Fig. 2-4.

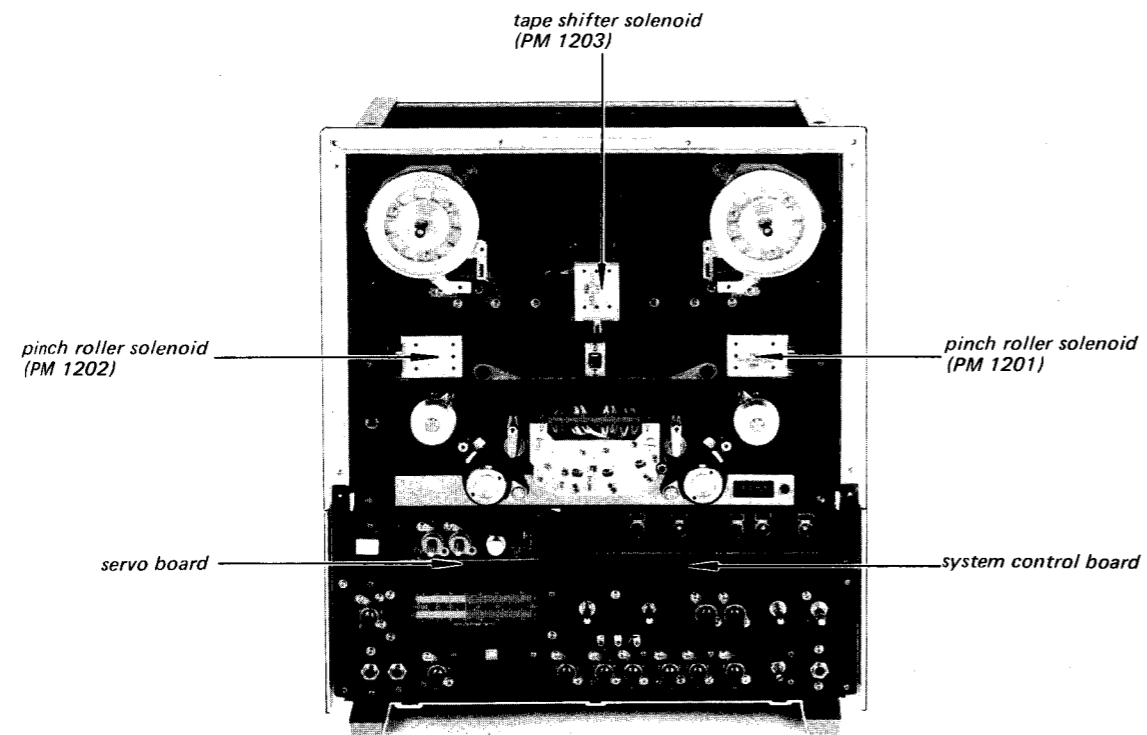

Fig. 2-5.

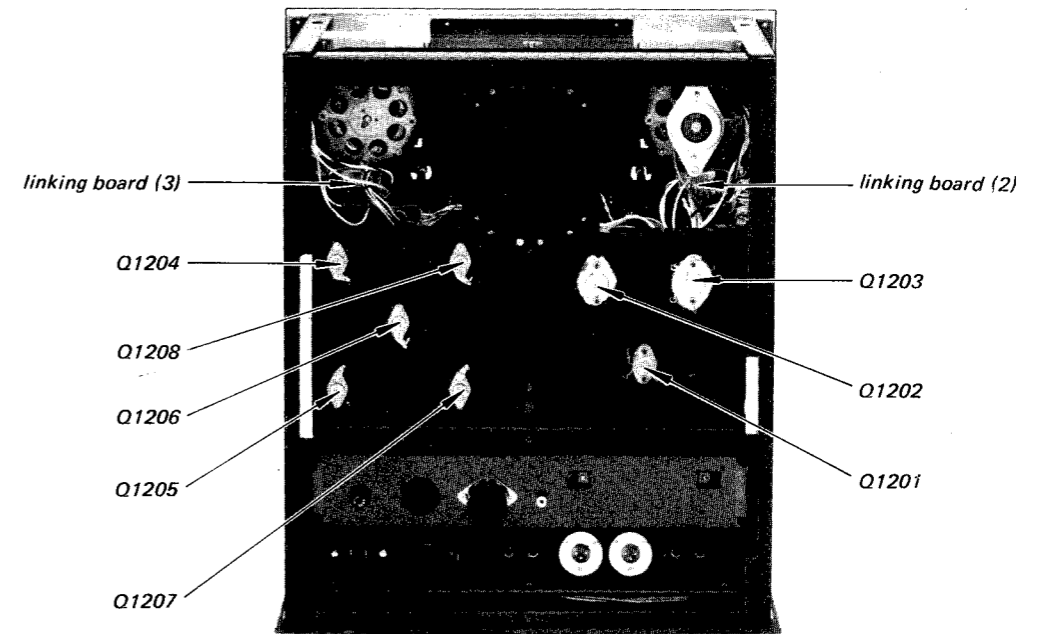

Fig. 2-6.



Fig. 2-8.

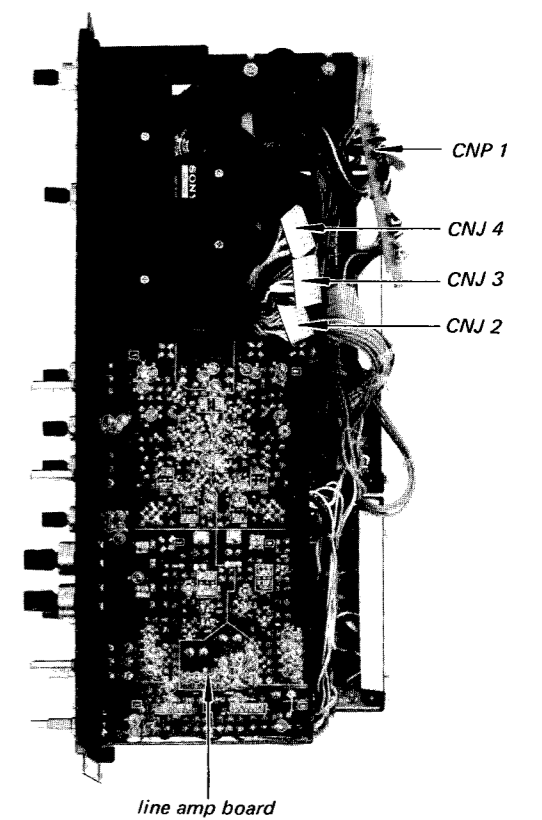

Fig. 2-7.

SECTION 3
MECHANICAL ADJUSTMENTS

3-1. BRAKE ADJUSTMENT

(3) Brake Torque Adj.

Change the hooking position of the spring for the brake torque specified in the table below.

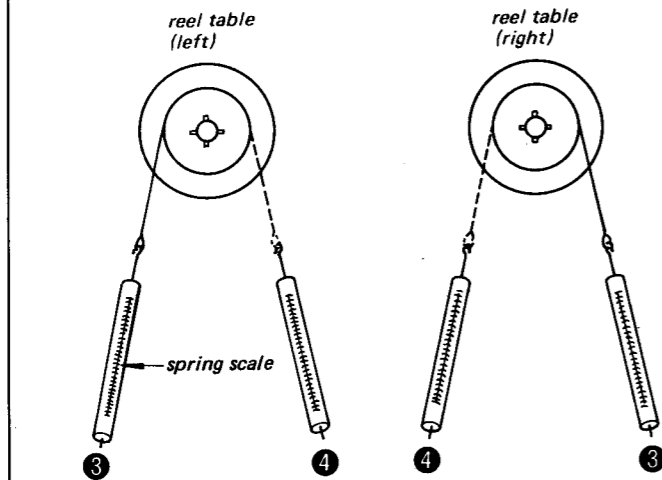

Torque (when brake is on)	
③	= 1800 ~ 2500 g·cm (25 ~ 34 oz·in)
④	= 600 ~ 700 g·cm (8.4 ~ 9.7 oz·in)

(1) Brake Arm Stopper Adj.

1. Mode: STOP
2. Loosen the screw **A** and place the brake stopper for the clearance **1**.
3. Secure the screw **A**.

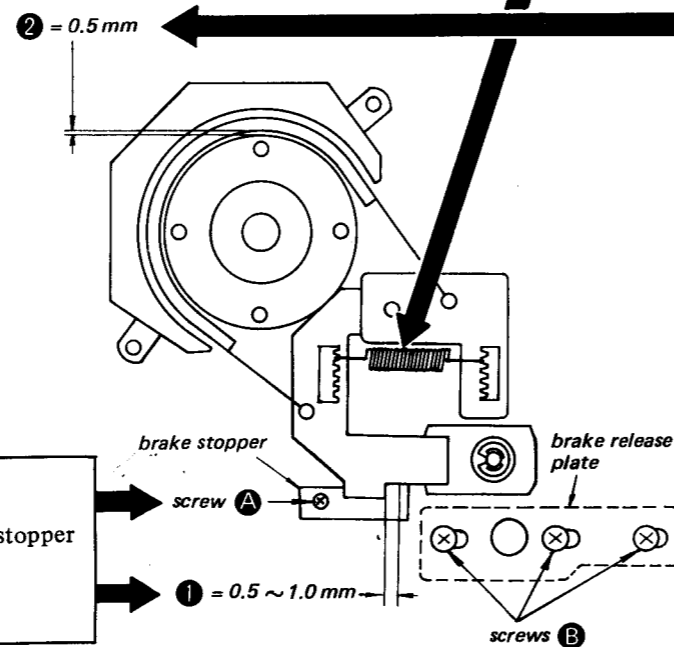

(2) Brake Release Lever's Stroke Adj.

1. Mode: PLAYBACK
2. Loosen the screws **B** and place the brake release plate for the clearance **2**.
3. Secure the screws **B**.

3-2. PINCH ROLLER PRESSURE

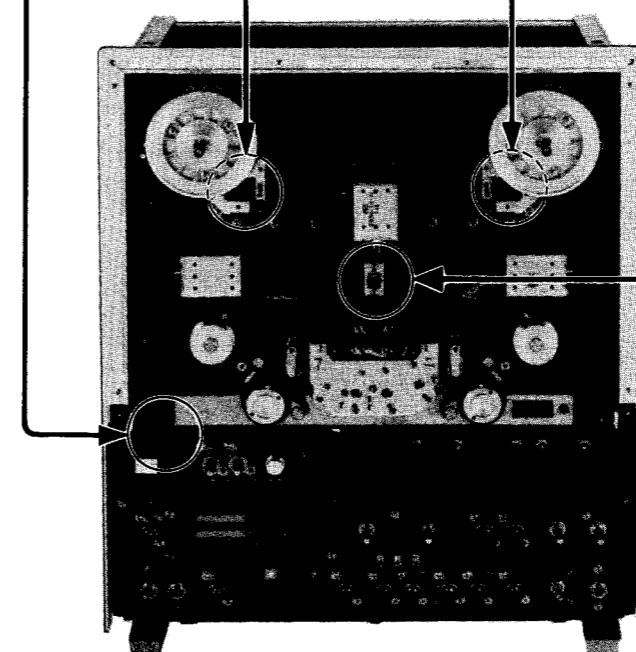
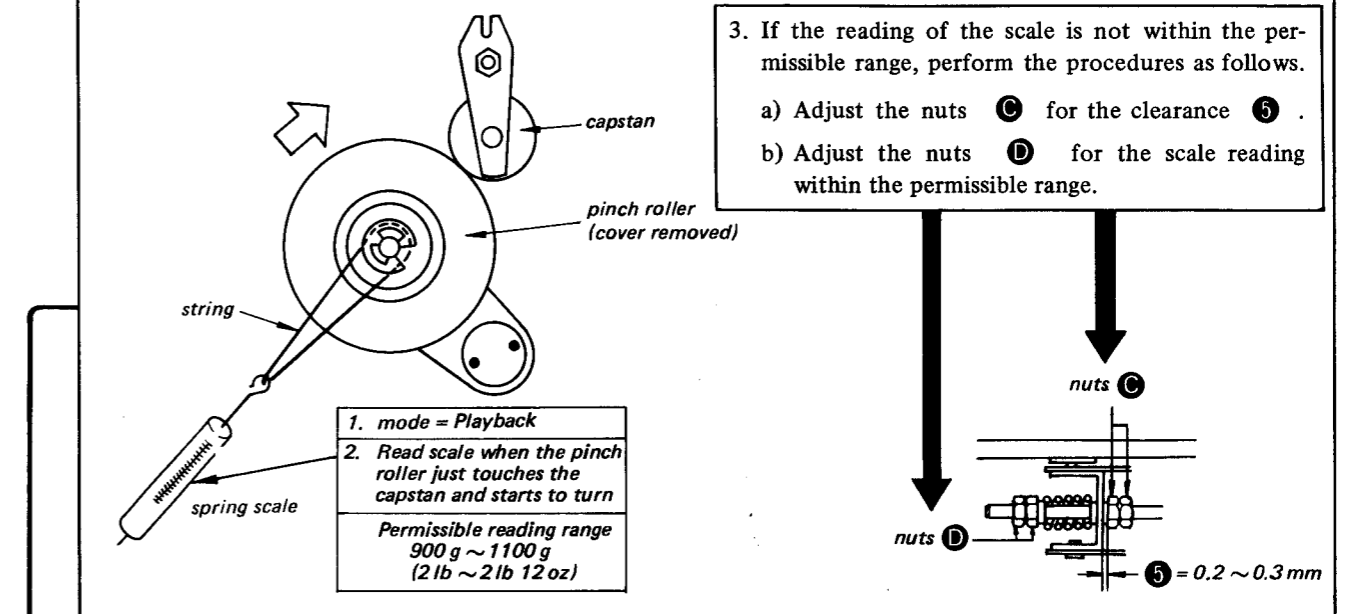

3-3. TAPE SHIFTER POSITION ADJUSTMENT

1. Mode: PLAYBACK
2. Adjust the screws **E** and move the adjustment plate **F** for the clearance **6**.
3. Make sure that the scrape filter roller does not touch the tape in the fast forward mode.

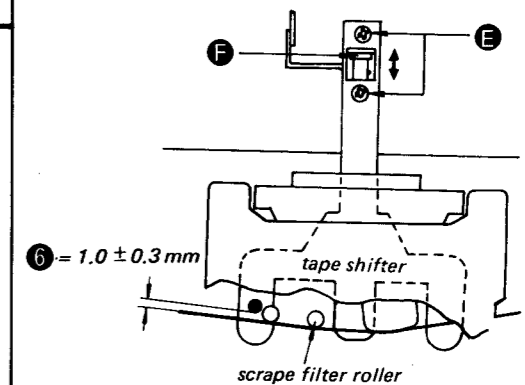

3-4. BACK TENSION AND TAKE-UP REEL TORQUE ADJUSTMENTS

Adjust each of adjustable resistors to obtain each torque specified in the table.

Fast Forward Back-Tension Torque Adj.

reel size	torque
7"	90 ± 10 g · cm (1.1 ~ 1.4 oz · in)
10"	110 ± 20 g · cm (1.3 ~ 1.8 oz · in)

Rewind Back-Tension Torque Adj.

reel size	torque
7"	90 ± 10 g · cm (1.1 ~ 1.4 oz · in)
10"	110 ± 20 g · cm (1.3 ~ 1.8 oz · in)

Playback Take-Up Reel Torque Adj.

reel size	torque
7"	350 ± 20 g · cm (4.6 ~ 5.1 oz · in)
10"	450 ± 20 g · cm (6.0 ~ 6.5 oz · in)

3-5. TAPE GUIDE ADJUSTMENTS

Switch Control	Position
TAPE SPEED	38

This adjustment is performed with a normal tape.

1. Mode: PLAYBACK

Adjust the tape guide **A** to make X and Y equal on the erase head.

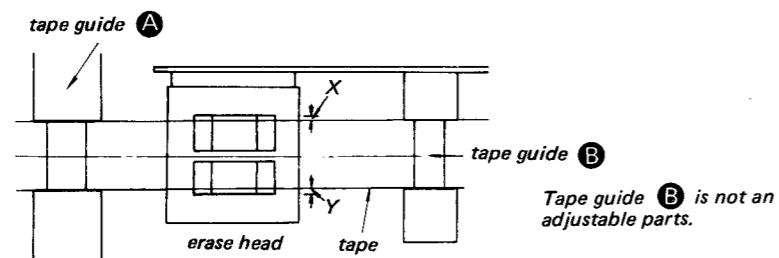

2. Make sure that the tape does not curl at the tape guide **C** and **D**.
If the tape curls, adjust those tape guides.

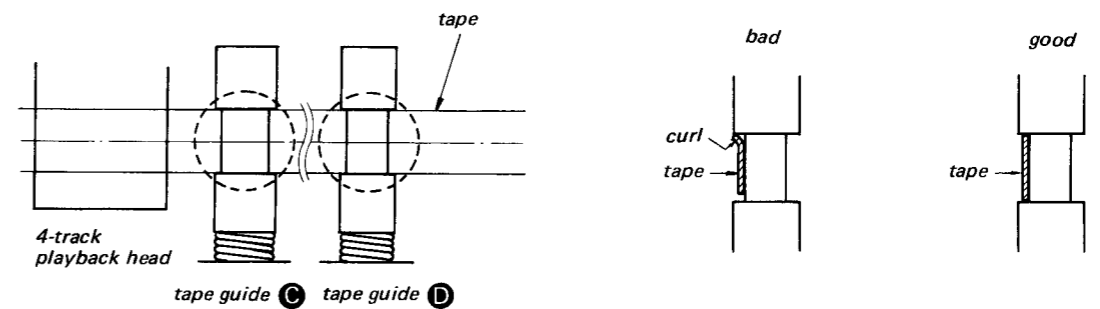

3. Mode: PLAYBACK

Step 1. By means of the screws **1**, adjust the height of the record head to make X1 and Y1 equal and the zenith of it to match the tape guide **B**.

Step 2. By means of the screws **2**, perform the same procedure as step 1 for 2-track playback head.

Step 3. By means of the screws **3**, adjust the height of 4-track playback head for the clearance **7** and the zenith of it to match the tape guide **B**.

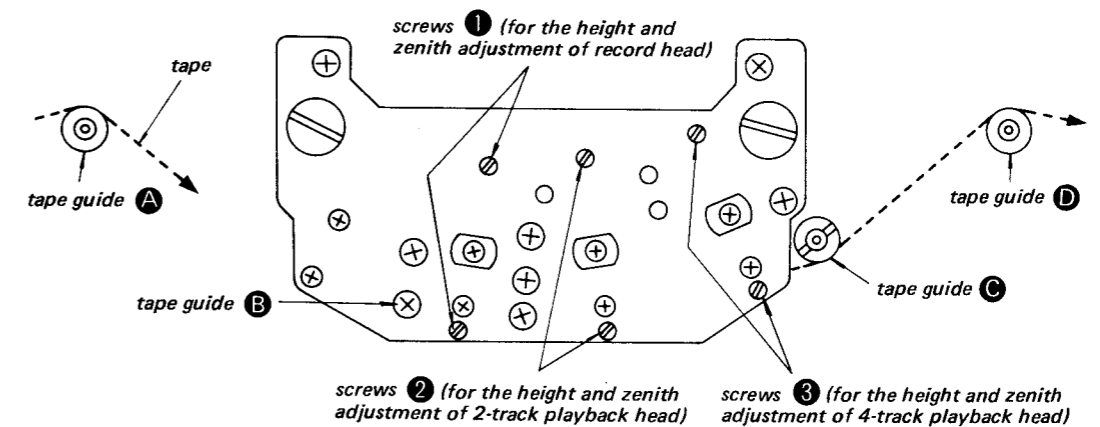
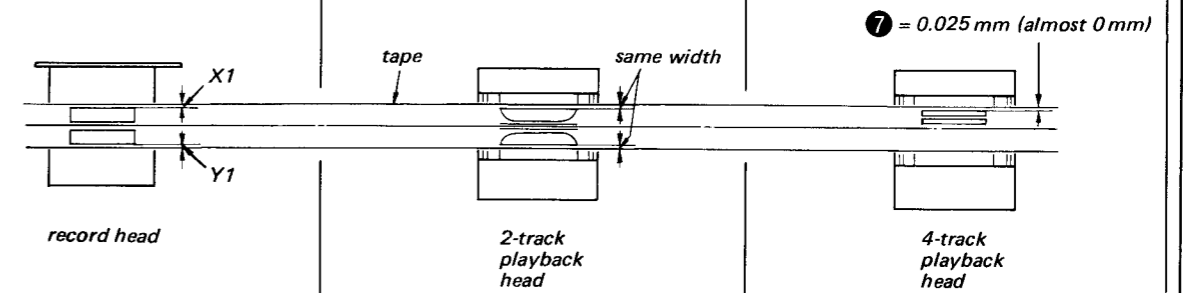

SECTION 4
ELECTRICAL ADJUSTMENTS

Required Sony Test Tapes are as follows.

Test Tape	TAPE SELECT switch		Remarks
	BIAS	EQ	
J-19-F2	NORMAL	NORMAL	400 Hz · 0 dB, 400 Hz/10 kHz/ 12.5 kHz/7 kHz/80 Hz/40 Hz · -10 dB
J-19-A2	NORMAL	NORMAL	12.5 kHz · -10 dB
SPC-47	NORMAL	NORMAL	4 kHz · 0 dB
NPS-1	NORMAL	NORMAL	blank (Sony normal tape)
SLH-S1	NORMAL	SPECIAL	blank (Sony SLH tape)
Fe-Cr-S1	NORMAL	Fe-Cr	blank (Sony Ferri-Chrome tape)

Switch and Control Positions are as follows unless otherwise noted.

Switch Control	Position	Switch Control	Position
METER	VU	TAPE SPEED	19 cm/sec (7½ ips)
MIC ATT	30	SPEED TUNING	off
INPUT SELECT	LINE	REC ATT	"16"
REC MODE (L and R)	REC	PB ATT (dB)	▲ ("10")
PB HEAD (playback head selector)	2	PB ATT (FINE)	CAL.
MONITOR	TAPE	TAPE SELECT (EQ)	NORMAL
REEL SIZE	7	TAPE SELECT (BIAS)	NORMAL

4-1. DC VOLTAGE ADJUSTMENT

Adjust each adjustable resistor to obtain each VOM reading.

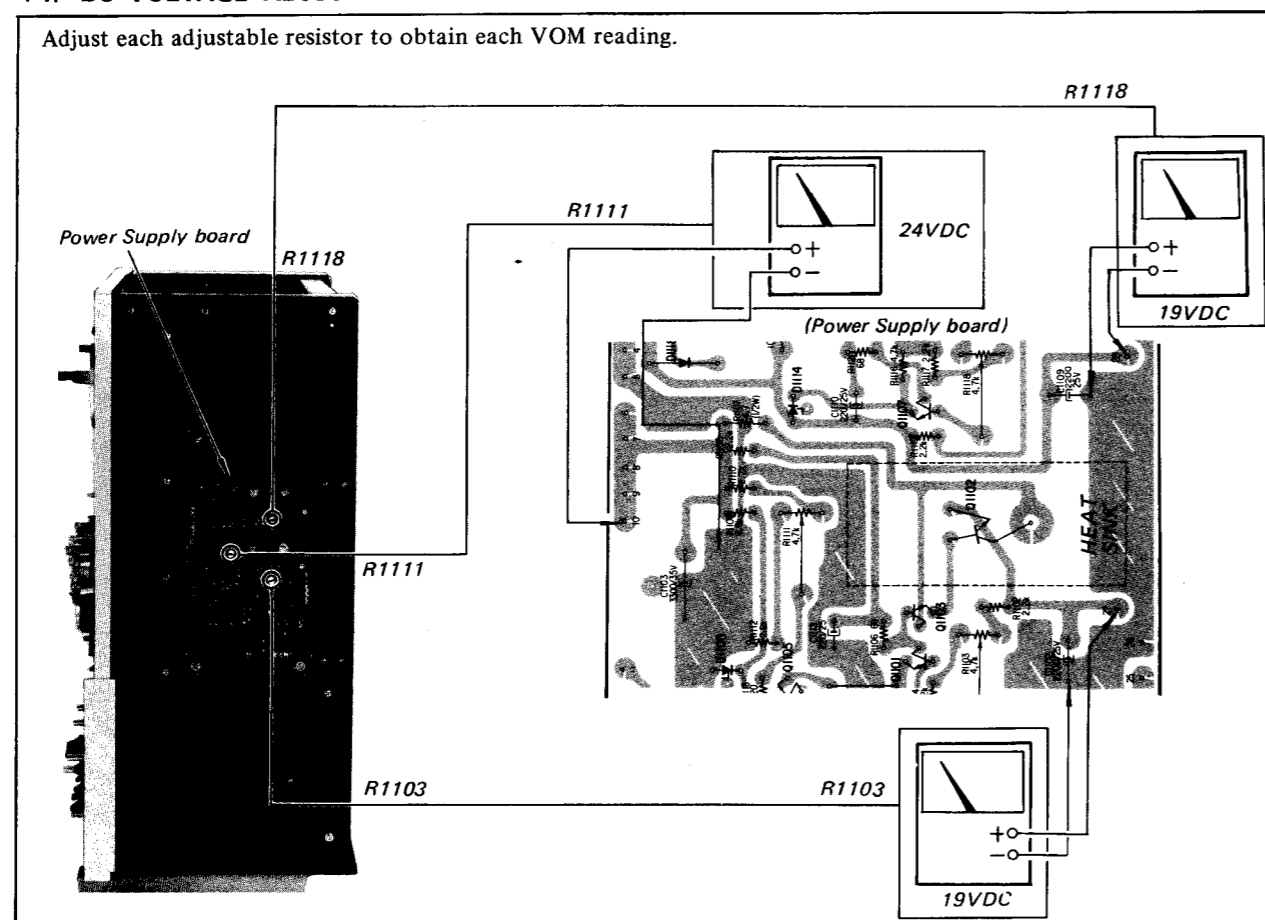

4-2. PLAYBACK AND RECORD HEADS LATERAL ALIGNMENT

Playback Heads:

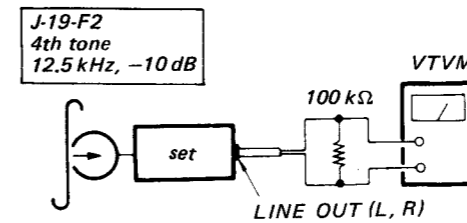

PB HEAD Switch Setting	Adjust	VTVM Reading
"2"	Loosen the screws A and adjust the head position.	maximum
"4"	Loosen the screws B and adjust the head position.	maximum

Record Head:

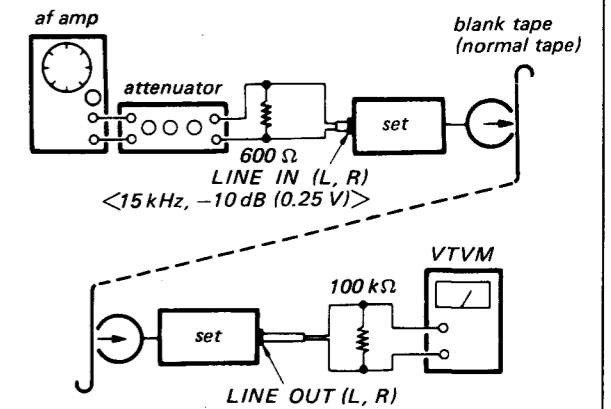

PB HEAD Switch Setting	Adjust	VTVM Reading
"2"	Loosen the screws C and adjust the head position.	maximum

After the alignments, secure the screws and apply locking compound to the screws.

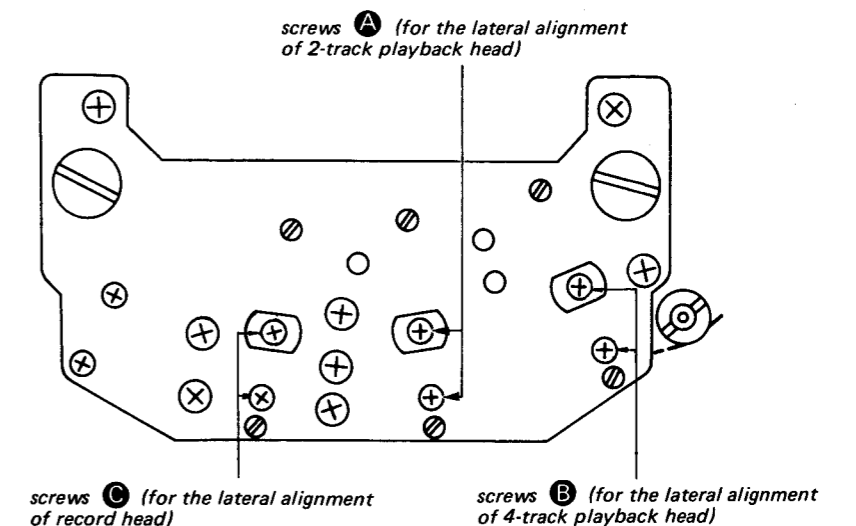

4.3. TAPE SPEED ADJUSTMENT

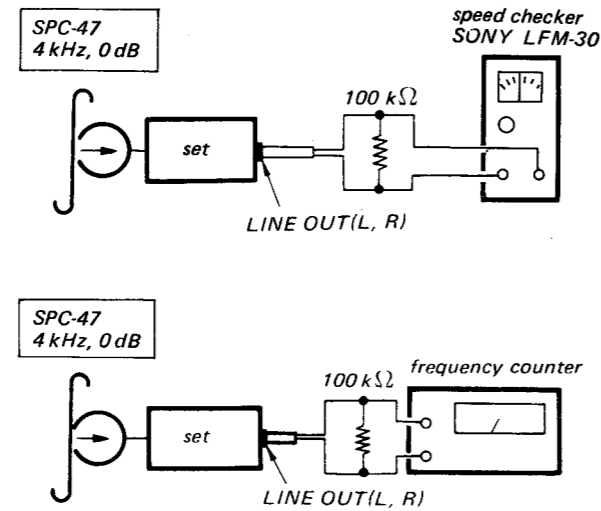

TAPE SPEED Switch Setting	Adjust	Speed Checker Reading	Frequency Counter Reading
19 cm/sec (7½ ips)	R1005	-0.1 ~ +0.1%	3,996 ~ 4,004 Hz
38 cm/sec (15 ips)	R1007	-0.1 ~ +0.1%	7,992 ~ 8,008 Hz

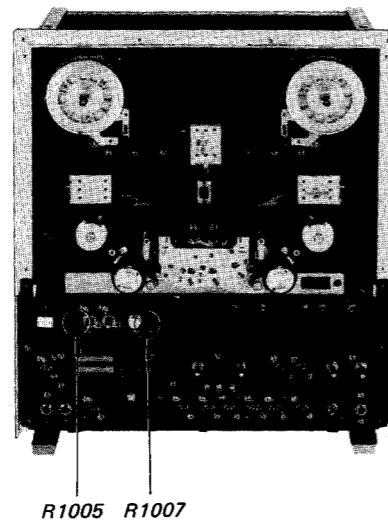

4.4. PLAYBACK HEAD AZIMUTH AND PHASE ADJUSTMENT

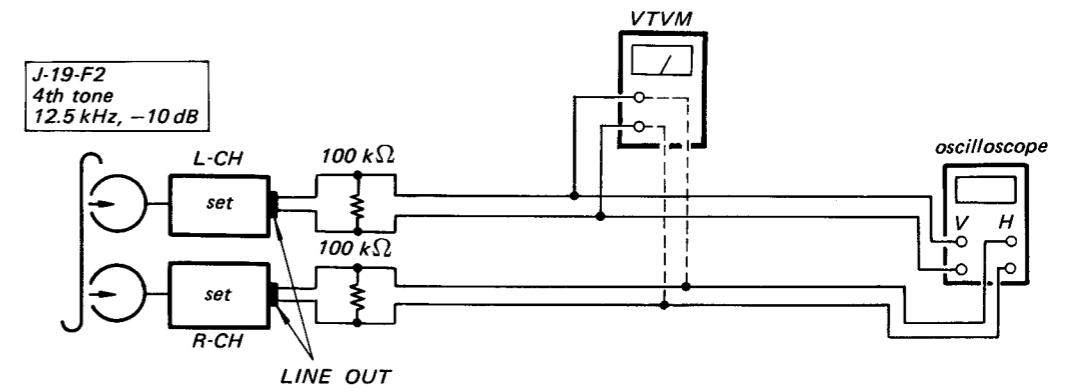

PB HEAD Switch Setting	Adjust	VTVM Reading	On the Oscilloscope			
"2"	screw D	maximum				
"4"	screw E	maximum	in-phase	30°	90°	more than 90°
			good		wrong	

Note: If the maximum peaks for L-ch and R-ch do not coincide, set the screw **D** or **E** to the mechanical mid of the two positions for the peaks. At this time, the level should change no more than 1 dB from the maximum peaks.

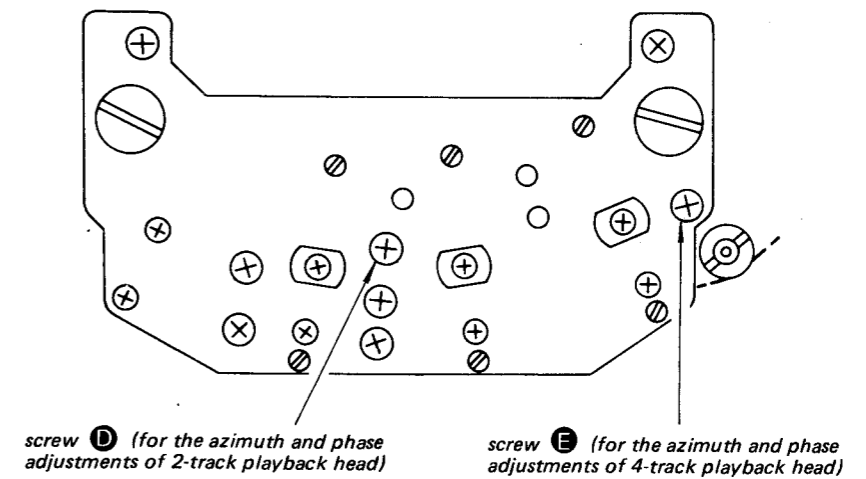

screw **D** (for the azimuth and phase adjustments of 2-track playback head)

screw **E** (for the azimuth and phase adjustments of 4-track playback head)

4.5. PLAYBACK LEVEL ADJUSTMENT

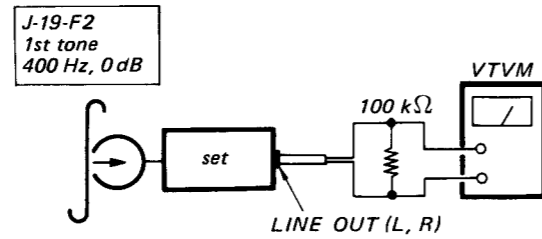

PB HEAD Switch Setting	Adjust	VTVM Reading
"2"	R324 (L-CH) R424 (R-CH)	-5 dB (0.44 V)
"4"	R325 (L-CH) R425 (R-CH)	

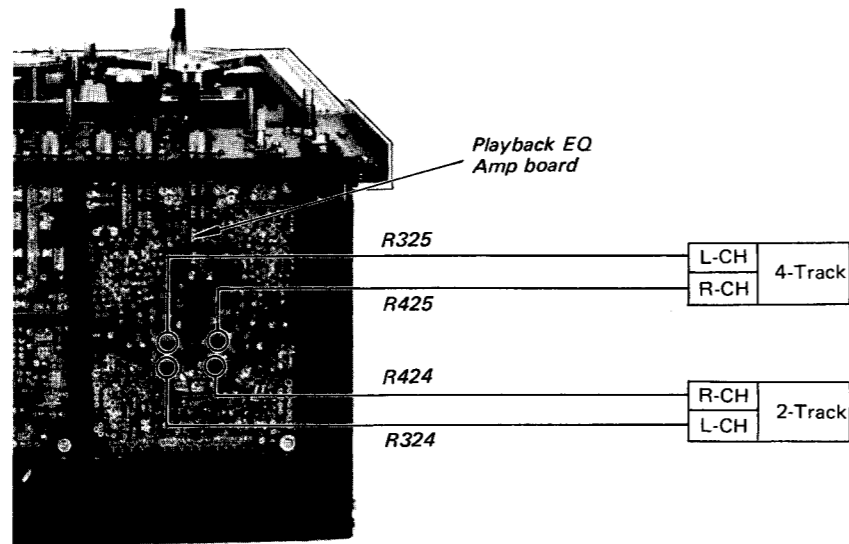

4.6. PLAYBACK EQUALIZER ADJUSTMENT

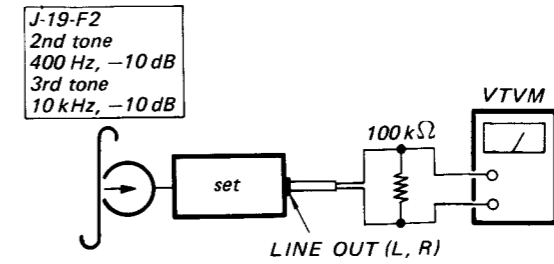

Step	PB HEAD Switch Setting	Test Tape J-19-F2	Adjust	VTVM Reading
1	"2"	2nd tone 400 Hz, -10 dB	---	Memorize the reading
2		3rd tone 10 kHz, -10 dB	R316 (L-CH) R416 (R-CH)	Same reading as Step 1
3	"4"	2nd tone 400 Hz, -10 dB	---	Memorize the reading
4		3rd tone 10 kHz, -10 dB	R317 (L-CH) R417 (R-CH)	Same reading as Step 3

Note: After this adjustment, perform the playback level adjustment again.

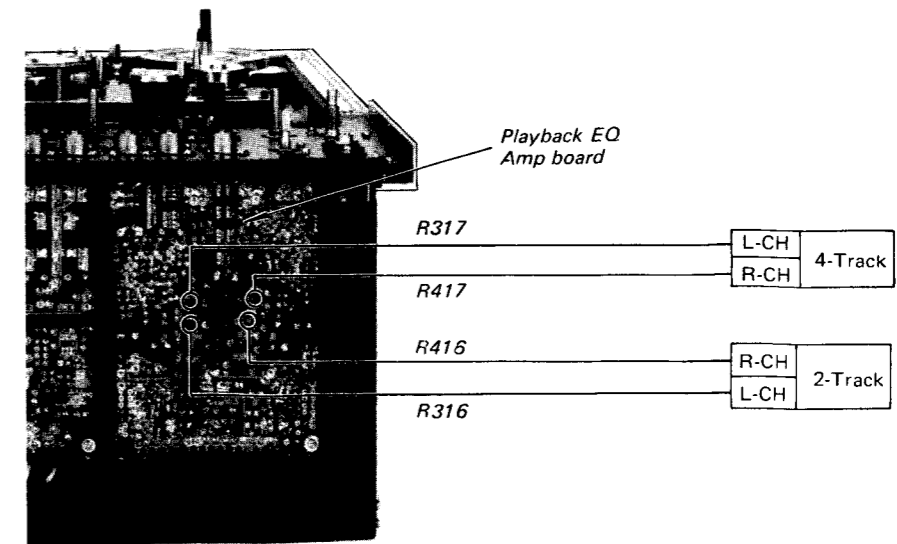

4-7. SYNC MODE (REC MODE SWITCH) PLAYBACK LEVEL ADJUSTMENT

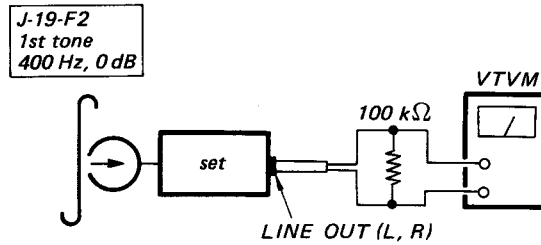

REC MODE Switch	Adjust	VTVM Reading
SYNC (L only)	R008 (L-CH)	-5 dB (0.44 V)
SYNC (R only)	R009 (R-CH)	

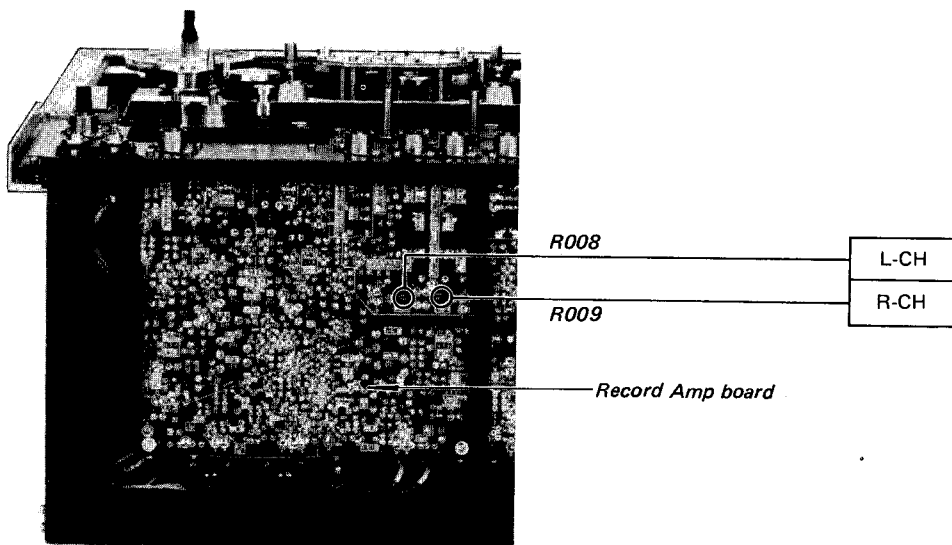

4-8. PEAK PROGRAM METER CALIBRATION

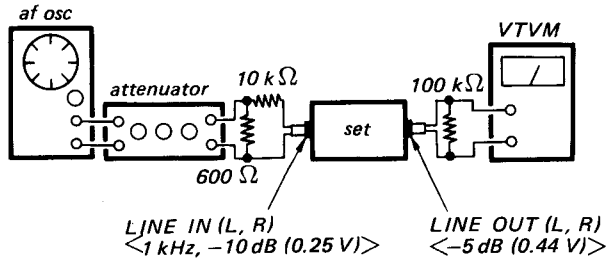

MONITOR Switch: SOURCE

Step	Mode	Adjust	Meter Reading
1	playback (with no input signal)	R371 (R-CH) R372 (L-CH)	0% on peak program meter
2	with REC button only pressed	---	-5 dB (0.44 V) on VTVM
3		R373 (R-CH) R374 (L-CH)	0 dB on peak program meter

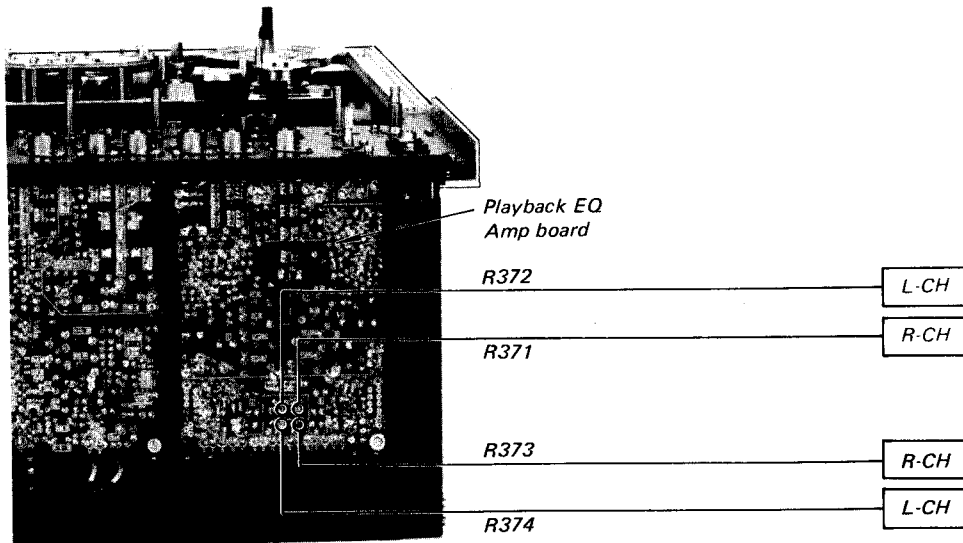

4-9. RECORD HEAD AZIMUTH AND PHASE ADJUSTMENT

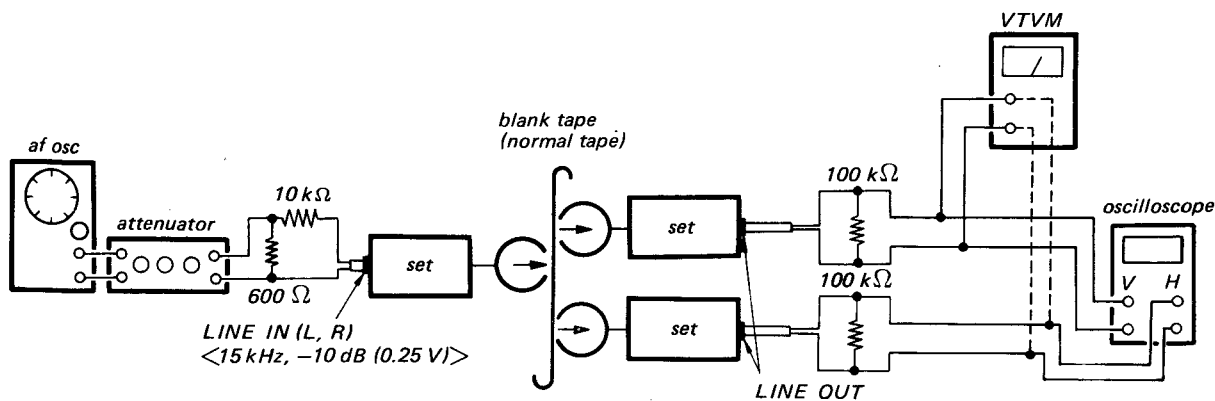

Adjust	VTVM Reading	On the Oscilloscope			
screw F	maximum				
		in-phase	30°	90°	more than 90°
		good		wrong	

Note: If the maximum peaks for L-CH and R-CH do not coincide, set the screw **F** to the mechanical mid of the two positions for the peaks. At this time, the level should change no more than 1 dB from the maximum peaks.

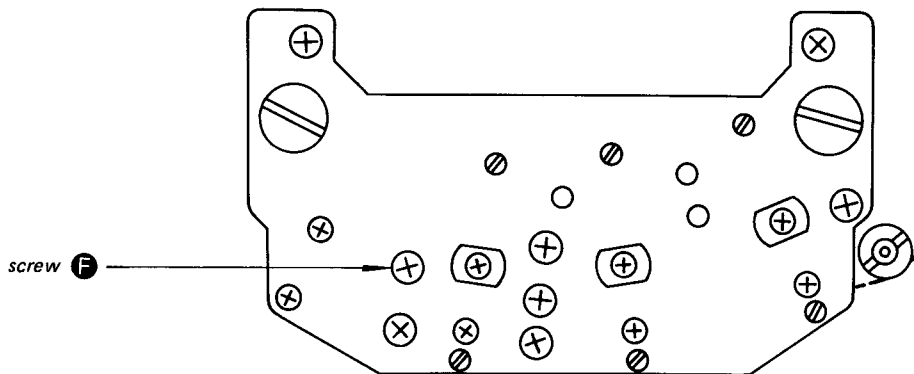

4-10. RECORD BIAS ADJUSTMENT

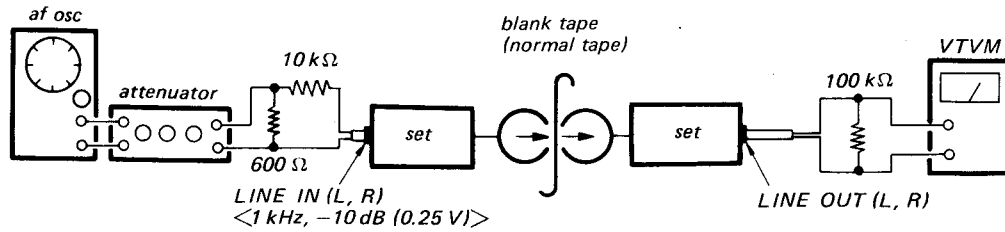

As trimmer capacitor C054 (L-CH) or C055 (R-CH) is slowly turned clockwise, VTVM reading will go up to a maximum and then start falling down. Adjust the capacitor until VTVM reads 0.5 dB below and beyond the maximum reading.

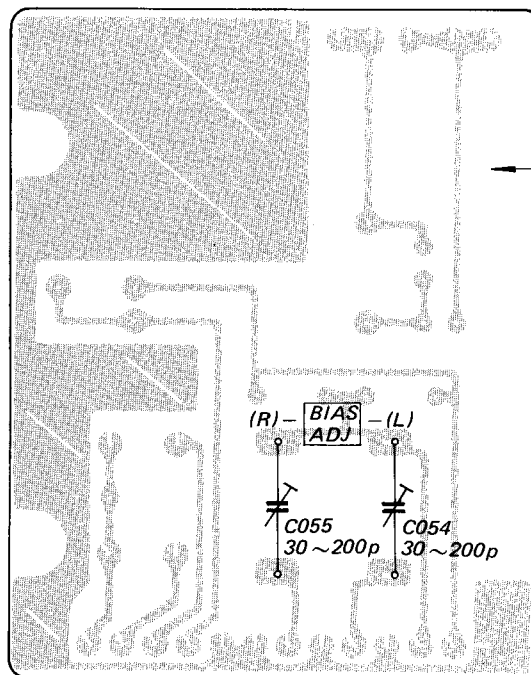
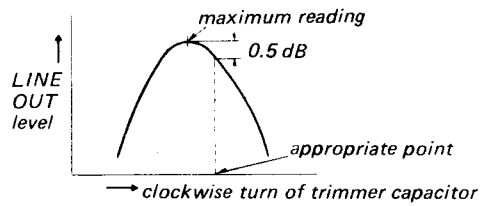

Bias Osc board

4-11. RECORD LEVEL ADJUSTMENT

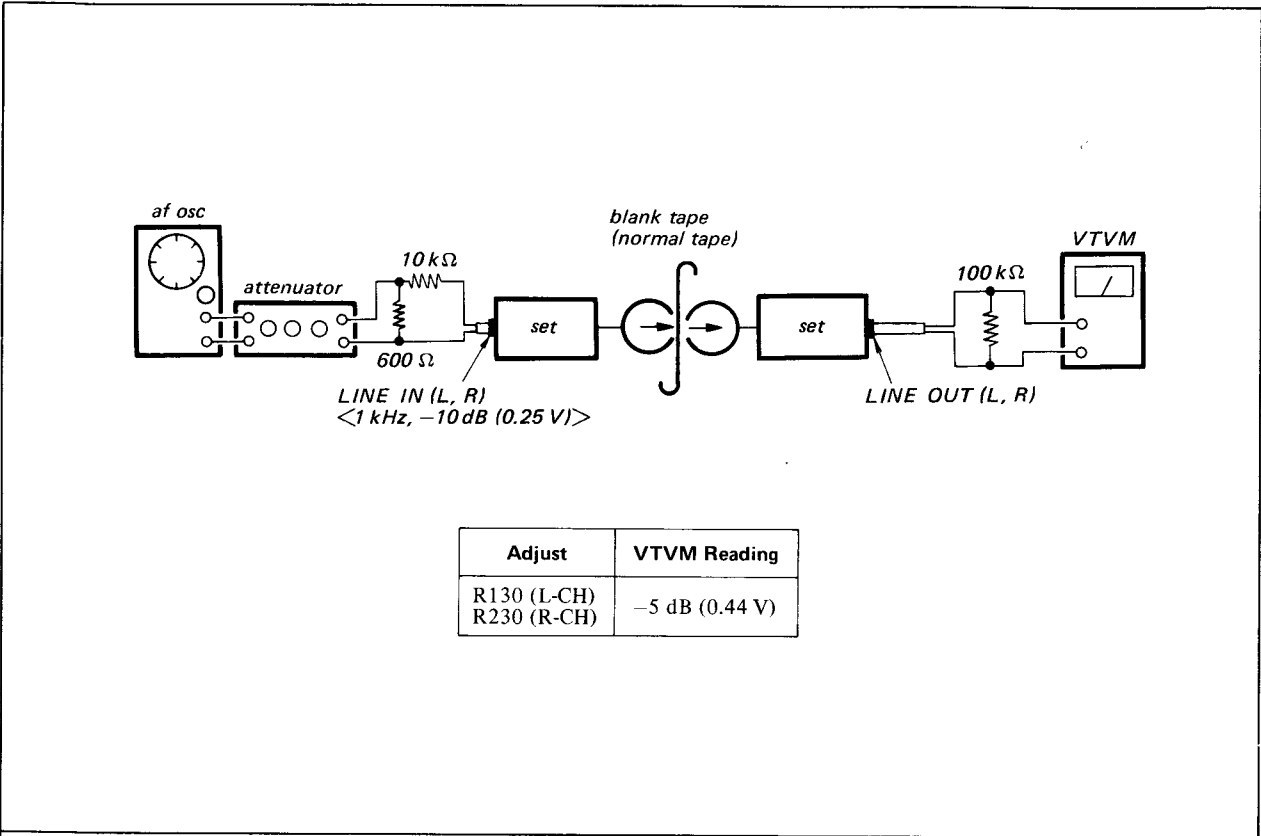

Adjust	VTVM Reading
R130 (L-CH) R230 (R-CH)	-5 dB (0.44 V)

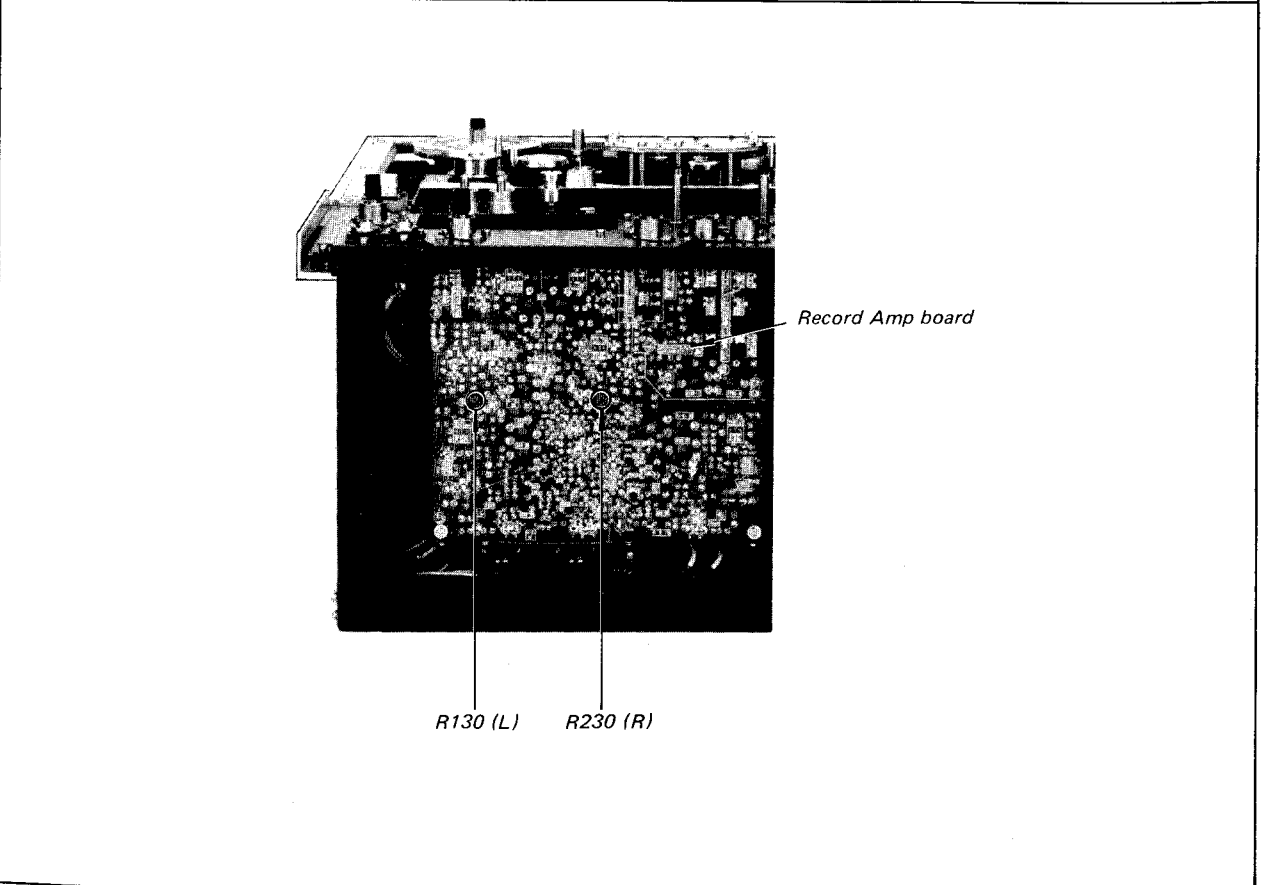

4-12. RECORDING EQUALIZER MID-RANGE ADJUSTMENT

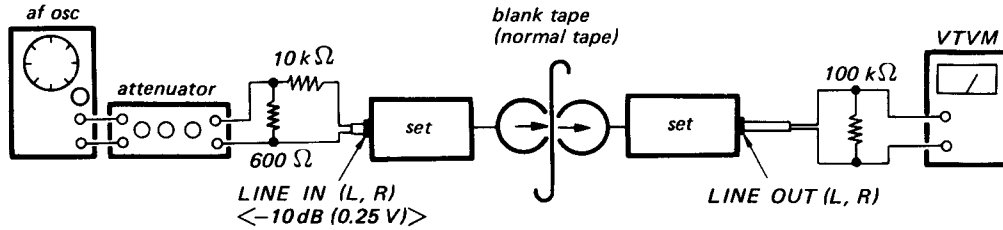

Step	Blank Tape	EQ Switch Setting	Input Signal Freq.	Adjust	VTVM Reading
1	NPS-1	NORMAL	1 kHz	—	Memorize the reading.
2	(Sony regular tape)		10 kHz	R148 (L-CH) R248 (R-CH)	Same reading as Step 1.
3	SLH-S1	SPECIAL	1 kHz	—	Memorize the reading.
4	(Sony SLH tape)		10 kHz	R151 (L-CH) R251 (R-CH)	Same reading as Step 3.
5	Sony Fe-Cr tape	Fe-Cr	1 kHz	—	Memorize the reading.
6			10 kHz	R154 (L-CH) R254 (R-CH)	Same reading as Step 5.

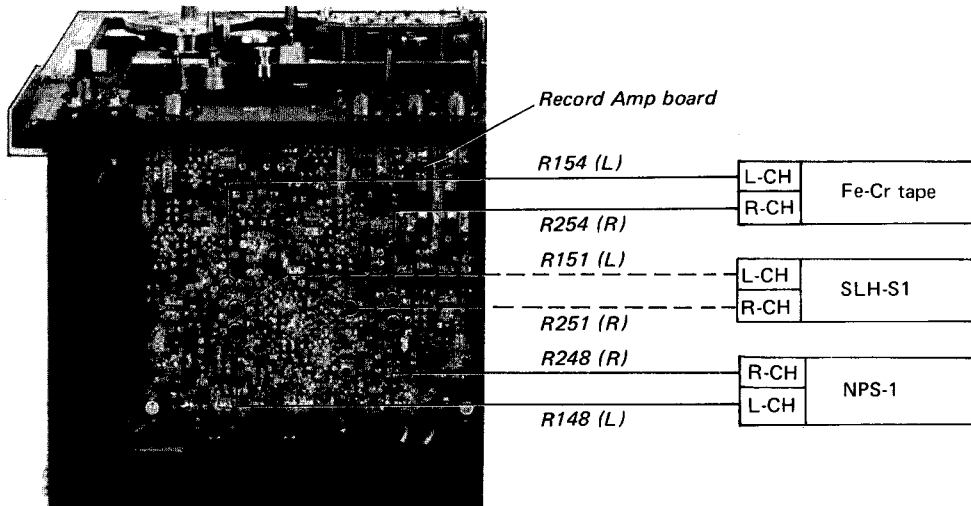

4-13. RECORDING EQUALIZER HIGH-RANGE ADJUSTMENT

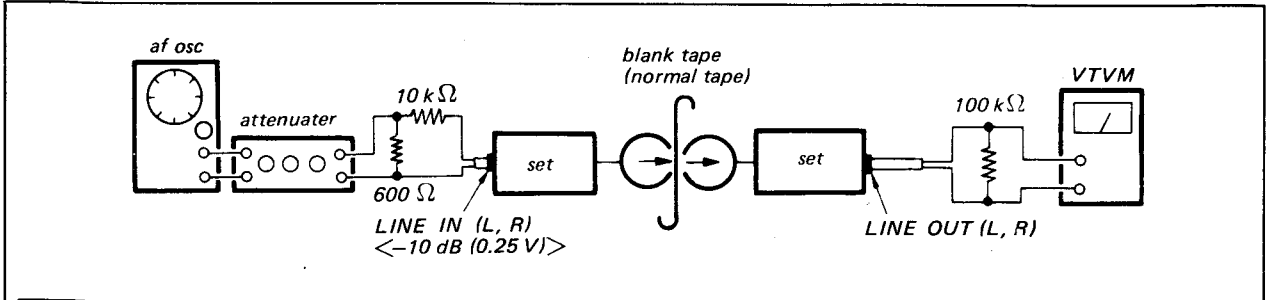

Step	Blank Tape	EQ Switch Setting	Tape Speed	Input Signal Freq.	Adjust	VTVM Reading
1	NPS-1 (Sony normal tape)	NORMAL	19 cm/s	1 kHz	---	Memorize the reading.
2			(7½ ips)	20 kHz	L105 (L-CH) L205 (R-CH)	Same reading as Step 1
3			38 cm/s	30 kHz		Memorize the reading.
4			(15 ips)	1 kHz	L102 (L-CH) L202 (R-CH)	Same reading as Step 3
5	SLH-S1 (Sony SLH tape)	SPECIAL	19 cm/s	1 kHz		---
6			(7½ ips)	25 kHz	L206 (L-CH) L106 (R-CH)	Same reading as Step 5
7			38 cm/s	35 kHz		Memorize the reading.
8			(15 ips)	1 kHz	L103 (L-CH) L203 (R-CH)	Same reading as Step 7
9	Sony Fe-Cr tape	Fe-Cr	19 cm/s	1 kHz		---
10			(7½ ips)	30 kHz	L207 (L-CH) L107 (R-CH)	Same reading as Step 9
11			38 cm/s	40 kHz		Memorize the reading.
12			(15 ips)	1 kHz	L104 (L-CH) L204 (R-CH)	Same reading as Step 11
			30 kHz			
				40 kHz		

Note: After the recording equalizer adjustments, perform the recording level adjustment again.

(1) for normal tapes (Sony PR)

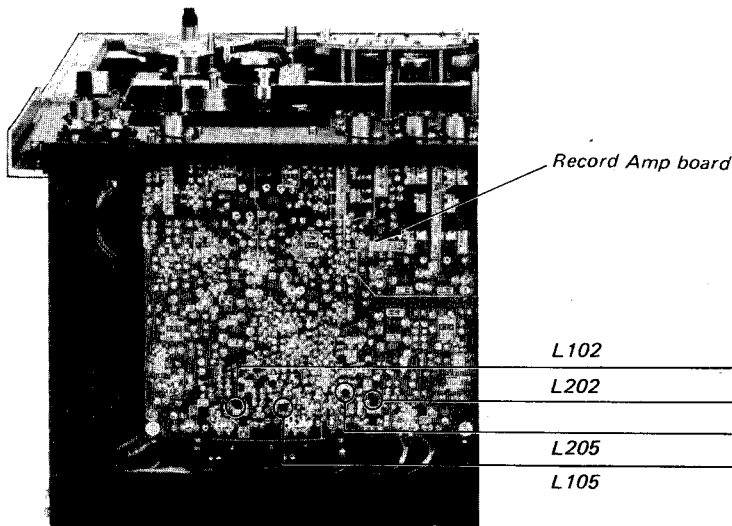

For Step 1 ~ 4	
CH	Tape Speed
L	38 cm/sec.
R	
R	19 cm/sec.
L	

(2) for Sony SLH tapes

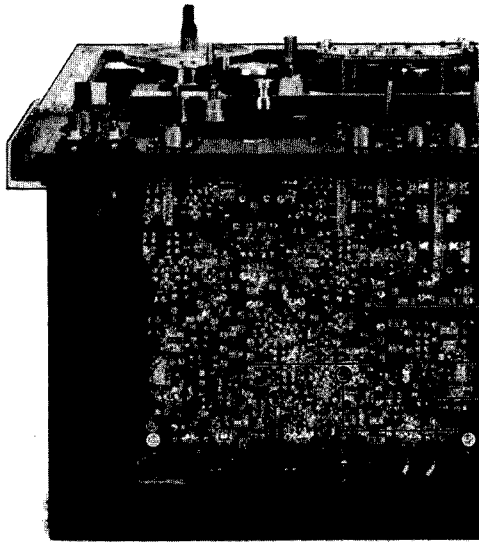

Record Amp board

L103
L203
L206
L106

For Step 5 ~ 8	
CH	Tape Speed
L	38 cm/sec.
R	
R	19 cm/sec.
L	

(3) for Fe-Cr tapes

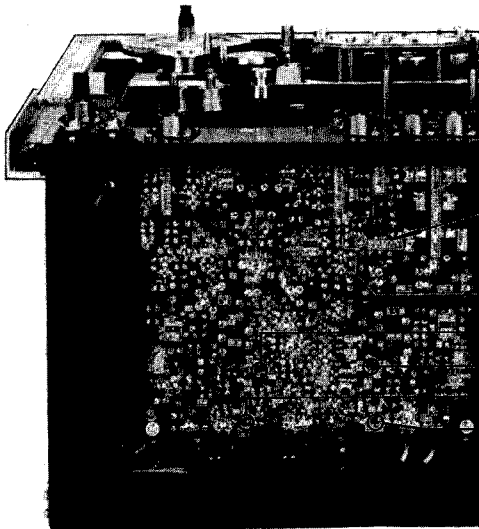

Record Amp board

L104
L204
L107
L207

For Step 9 ~ 12	
CH	Tape Speed
L	38 cm/sec.
R	
R	19 cm/sec.
L	

4-14. BIAS TRAP ADJUSTMENT

Mode: record (with no input signal)

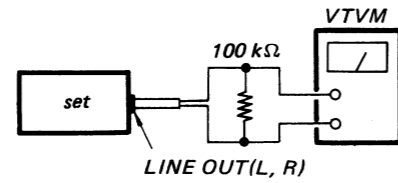

Adjust	VTVM reading
L101 (L-CH) L201 (R-CH)	minimum

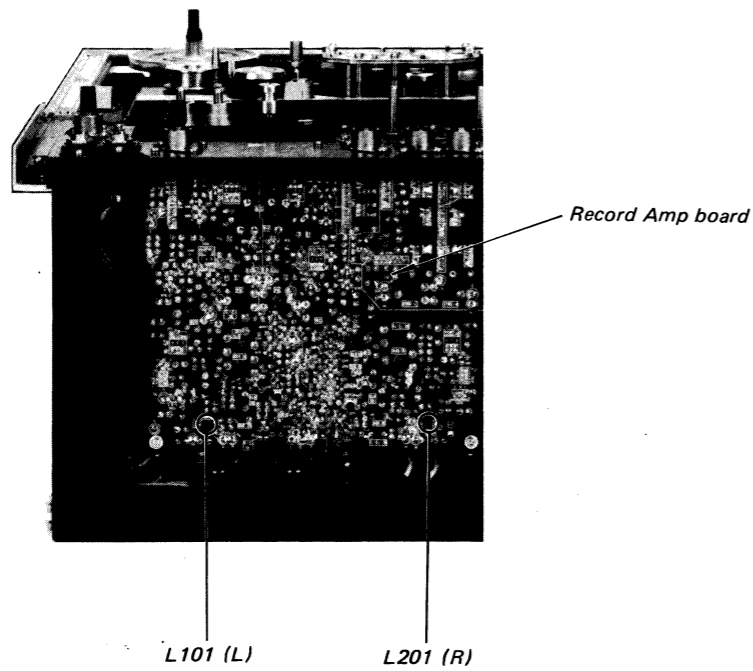

4-15. DUMMY COIL ADJUSTMENT

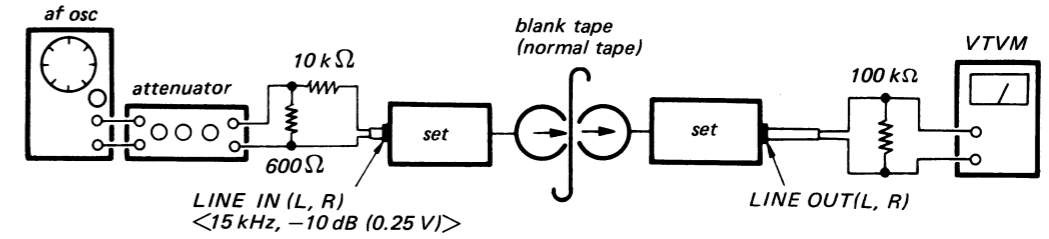

Step	Mode	Adjust	VTVM reading
1	both channel, record	-	Memorize the reading
2	L-channel only, record	L051	Same reading as Step 1.
3	R-channel only, record	L052	Same reading as Step 1.

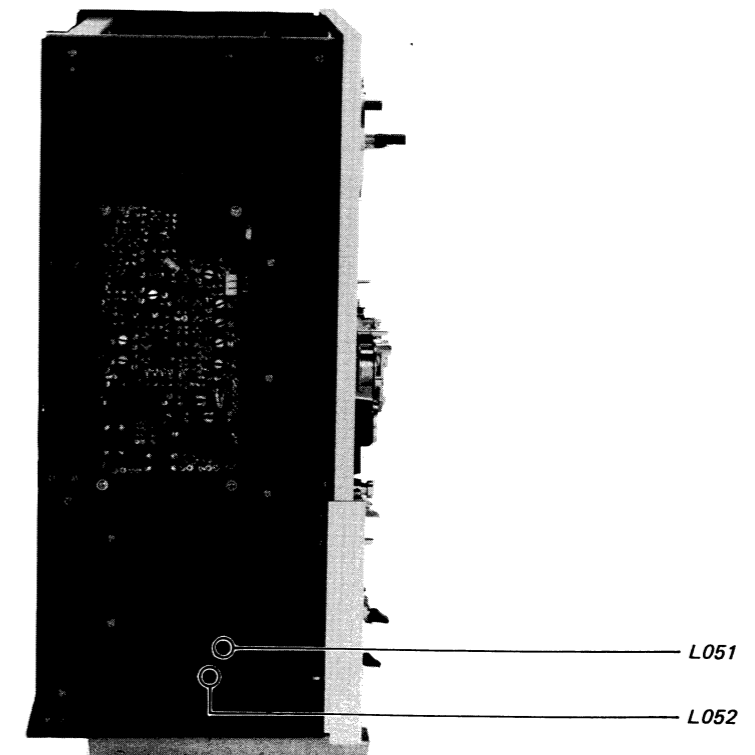

SECTION 5
DIAGRAMS

5-1. MOUNTING DIAGRAM [AMPLIFIER SECTION] - Conductor Side - (1)

Q101(201), 106(206)
Q111(211): 2SK58

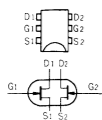

Q112(212): 2SA735

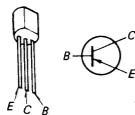

Q103(203), 104(204),
Q108(208), 109(209): 2SA705

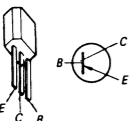

Q114(214): 2SA706

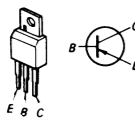

Q102(202), 105(205),
Q107(207), 110(210): 2SC1362-4
Q105~123(215~223): 2SC1364

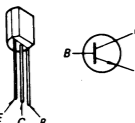

IC001: TA7122AP



D191~194: 1T40

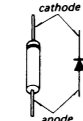

Note:

- All capacitors are in μF unless otherwise noted. 50 or less working volts are omitted except for electrolytic type. $p = \mu\mu\text{F}$.
- Color in () indicates color of sleeving over the end portion of shielded wire.

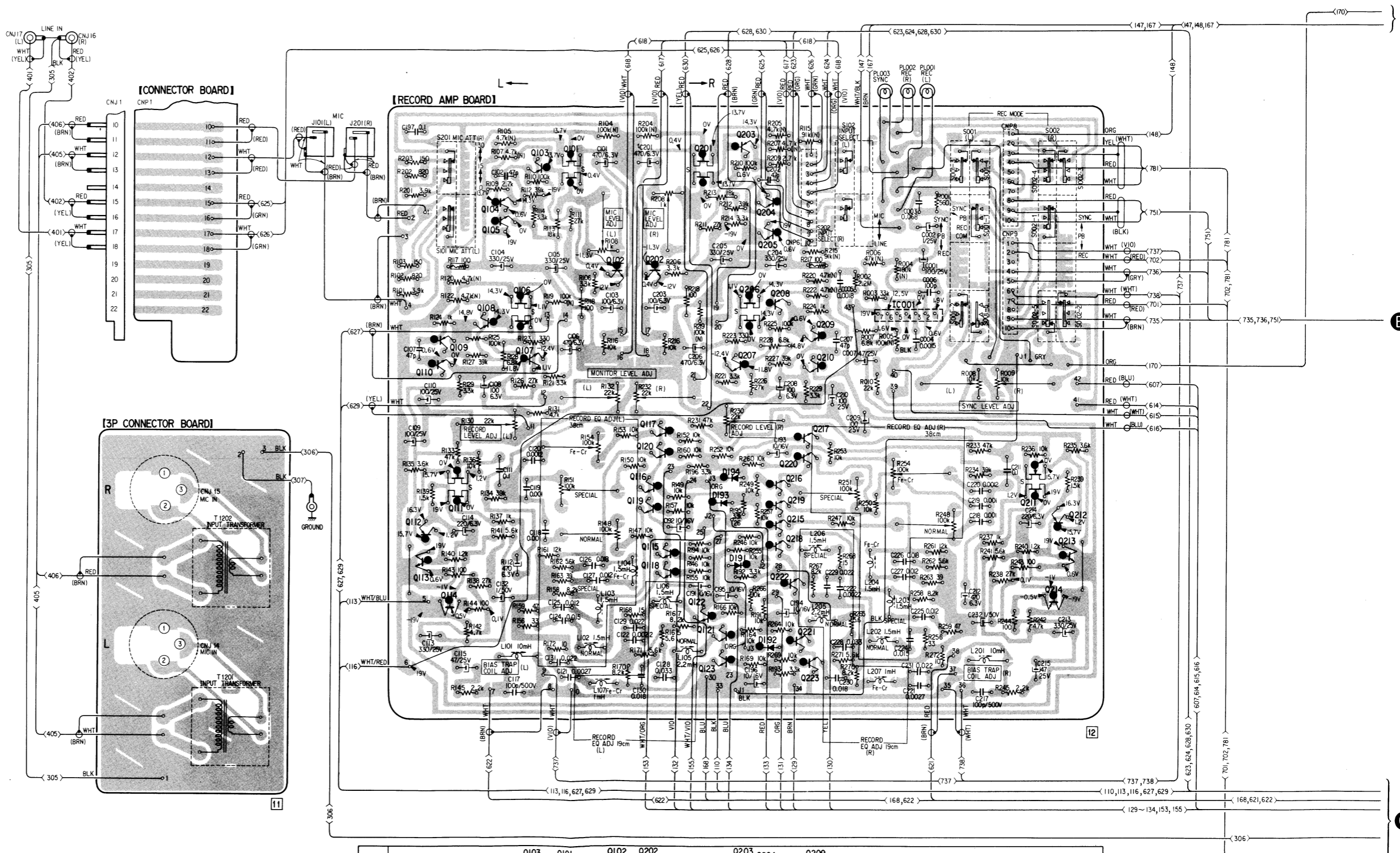

Q, IC	Q109 Q110 Q111	Q104 Q105 Q108	Q103 Q106 Q107	Q101	Q102 Q202 Q210	Q201	Q203 Q204 Q206	Q208 Q217 Q220 Q221 Q223	IC001	Q211 Q212 Q213 Q214
D	Q112 Q113 Q114				Q116 Q119	Q122 Q121 Q123	D193 D194 D192		D002 D001	

TC-880-2 TC-880-2

(2)

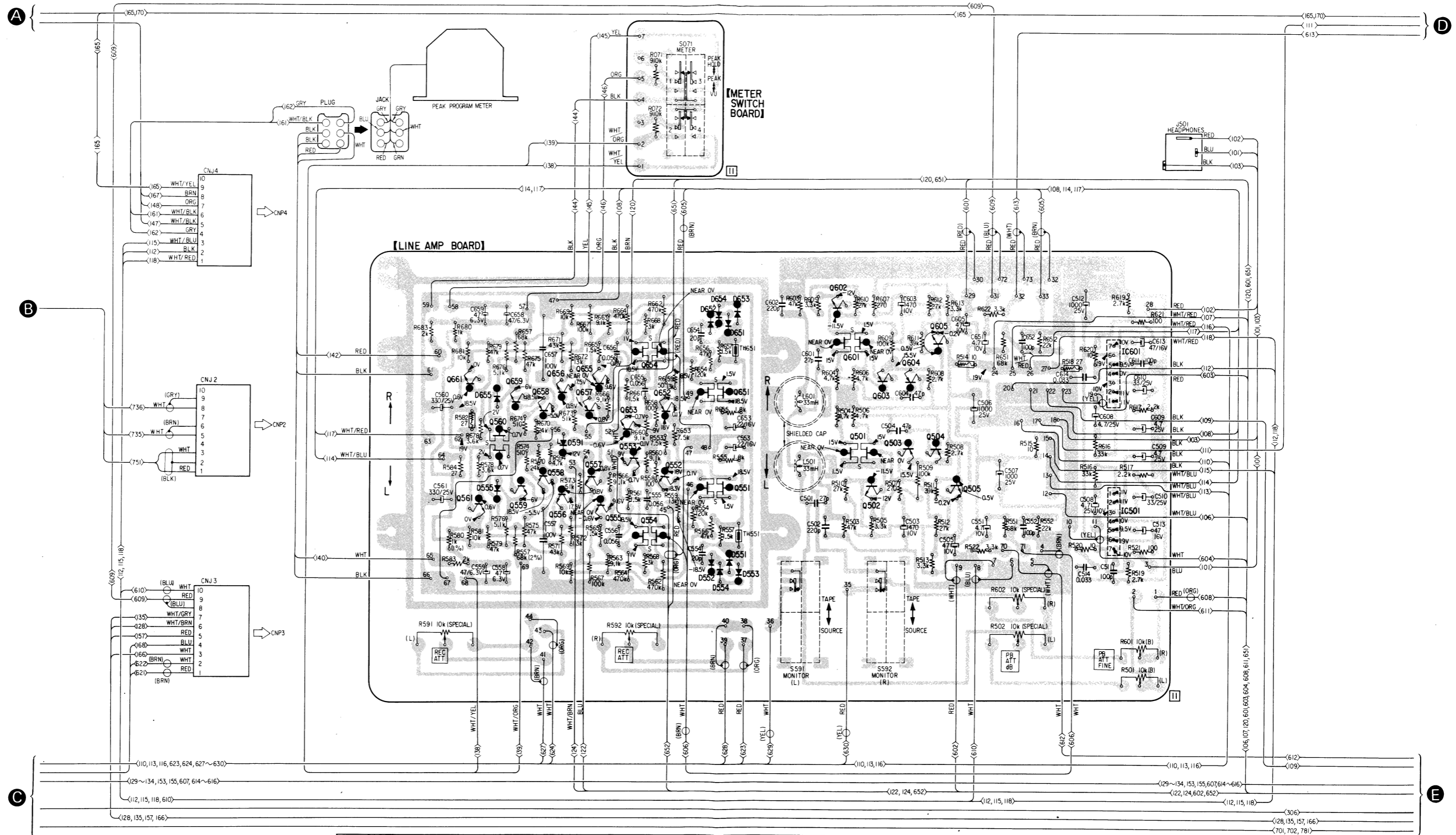

Q & IC	Q661 Q561	Q659 Q559	Q658 Q558	Q656 Q556	Q657 Q557	Q655 Q555	Q653 Q553	Q654 Q554	Q652 Q552	Q651 Q551	Q602 Q501	Q601 Q502	Q603 Q503	Q604 Q504	Q605 Q505	IC601 IC501
D	D655 D555		D591							D652 D654 D651 D653 D552 D554 D551 D553						

Q501 (601), 551 (651)
Q554 (654), 560: 2SK58

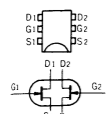

Q503 (603), 504 (604)
Q552 (652), 558 (658): 2SA735

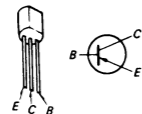

Q502 (602): 2SC1362-4
Q505 (605), 553 (653)
Q555 ~ 557 (655 ~ 657): 2SC1364
Q559 (659), 561 (661)

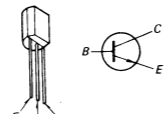

IC501 (601): TA7066P

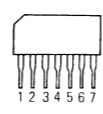

D551 (651), 553 (653): 1S1555
D552 (652), 554 (654): 1T22A

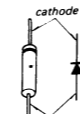

D591 (691): MZ12

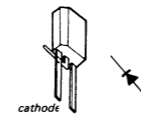

D555 (655): 10D2

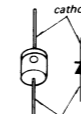

Note:

- All capacitors are in μF unless otherwise noted. 50 or less working volts are omitted except for electrolytic type. $\mu = \mu\text{F}$.
- Color in () indicates color of sleeving over the end portion of shielded wire.

(3)

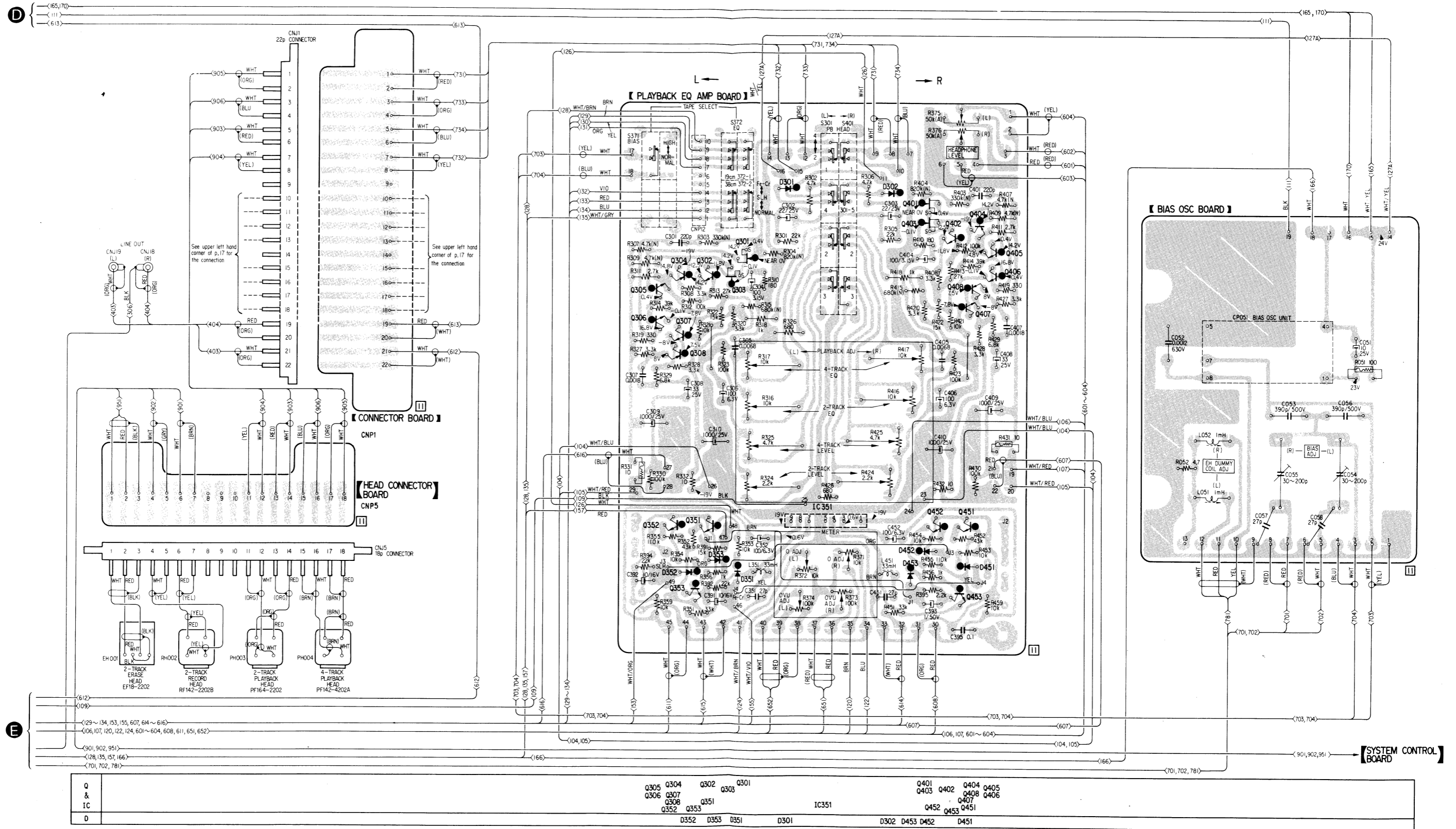

Q301 (401), 303 (403): 2SK43

Q308 (408): 2SA735

Q304 (404), 305 (405): 2SA705

Q302 (402), 306 (406)
Q307 (407): 2SC1362-4
Q351 ~ 353 (451 ~ 453): 2SC1364

IC351: BX270A

D301, 302
D351 ~ 353 (451 ~ 453): 1T40

Note:

- All capacitors are in μF unless otherwise noted. 50 or less working volts are omitted except for electrolytic type. $p = \mu\mu\text{F}$.
- Color in () indicates color of sleeving over the end portion of shielded wire.

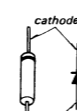
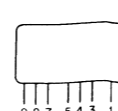
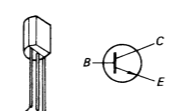
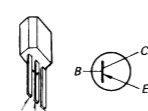
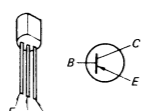
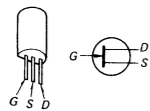

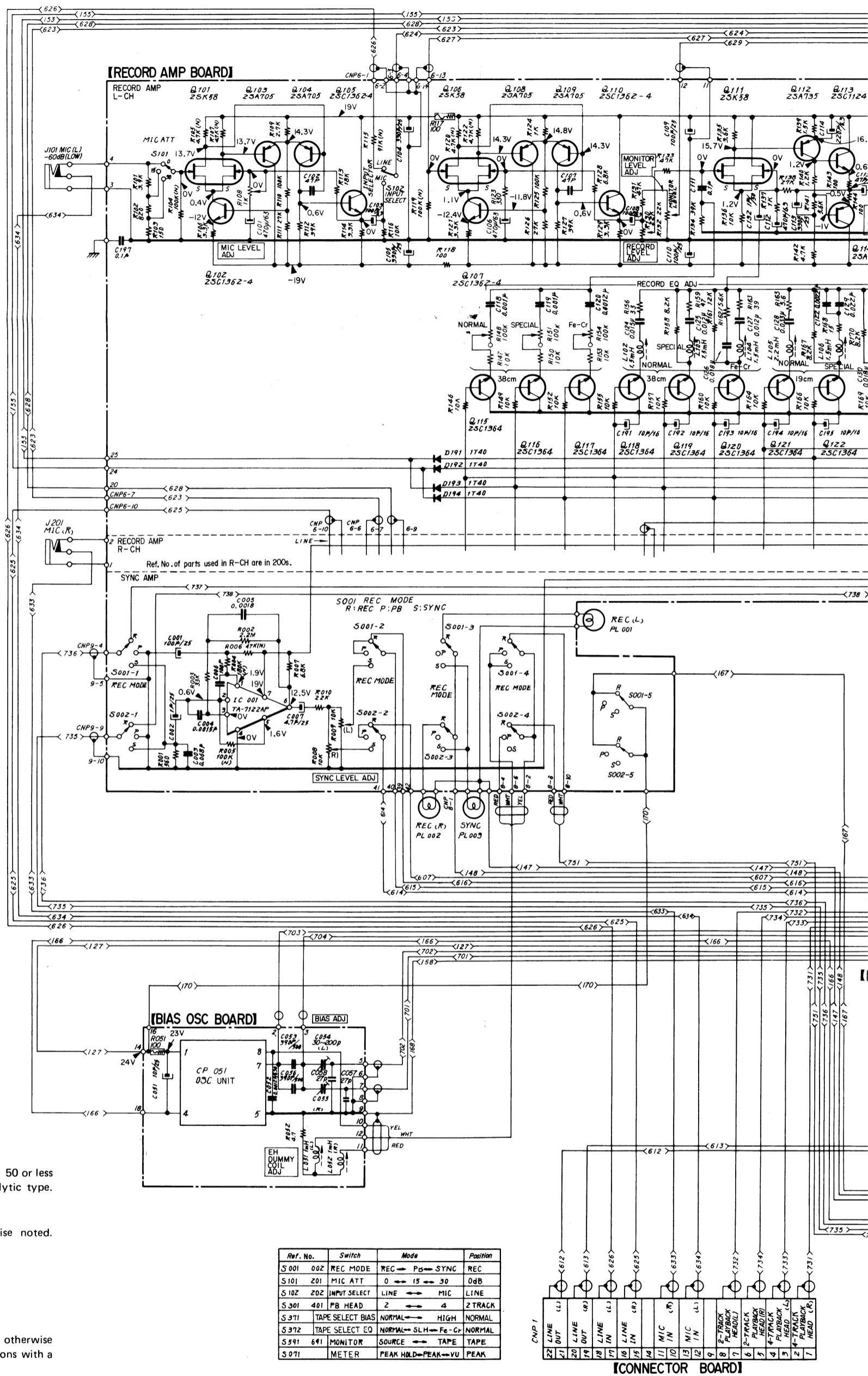

Note:

- All capacitors are in F unless otherwise noted. 50 or less working volts are omitted except for electrolytic type. (p = μF)
Ex. 000μ/00 = 000μF/00 V
- All resistors are in Ω, ¼W, unless otherwise noted. k = 1,000 M = 1,000k
- $\left\{ \begin{matrix} R000 \\ 00k \\ (0\%) \end{matrix} \right\} = \left\{ \begin{matrix} R000 \\ 00k\Omega \\ (\pm\%) \end{matrix} \right\}$
- ⊥ indicates chassis ground.
- (N) : indicates a low-noise resistor.
- Voltages are DC with respect to ground unless otherwise noted. Readings taken under no-signal conditions with a VOM (20 kΩ/V).
- Voltage variations may be noted due to normal production tolerances.

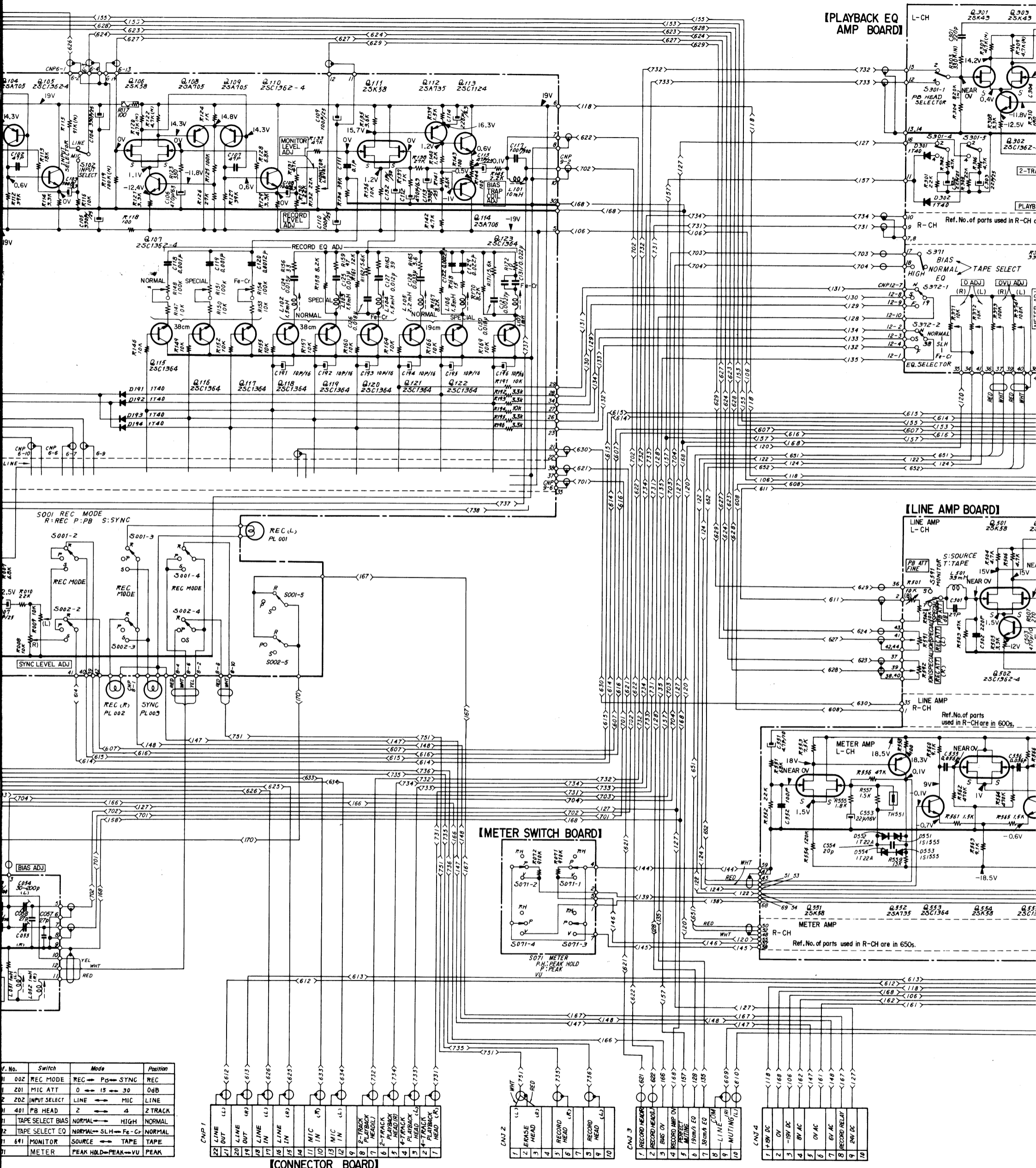

[PLAYBACK EQ AMP BOARD]

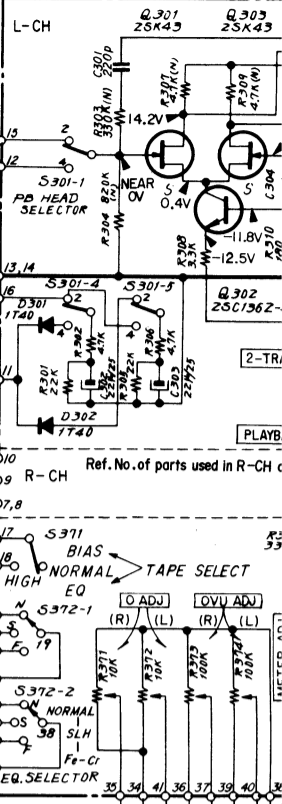

[LINE AMP BOARD]

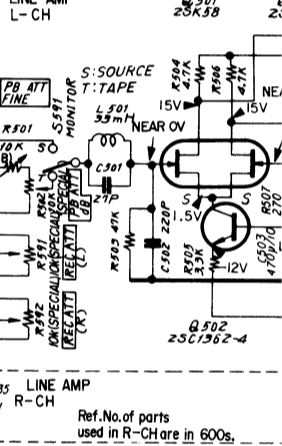

[METER SWITCH BOARD]

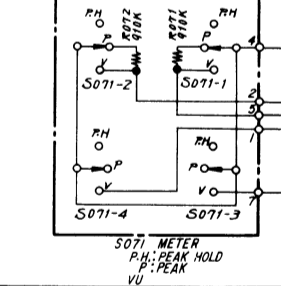

[CONNECTOR BOARD]

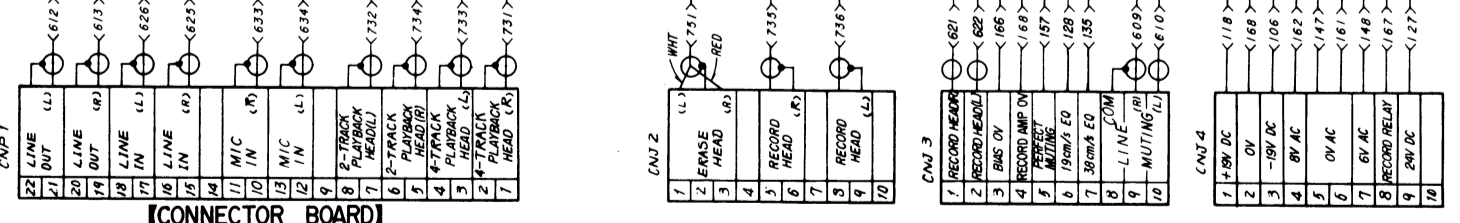

F. No.	Switch	Mode	Position
002	REC MODE	REC → Ps → SYNC	REC
201	MIC ATT	0 → 15 → 30	0dB
202	INPUT SELECT	LINE → MIC	LINE
401	PB HEAD	2 → 4	Z TRACK
1	TAPES SELECT BIAS	NORMAL → HIGH	NORMAL
2	TAPES SELECT EQ	NORMAL → SLH → Fe-Cr	NORMAL
691	MONITOR	SOURCE → TAPE	TAPE
71	METER	PEAK HOLD → PEAK → VU	PEAK

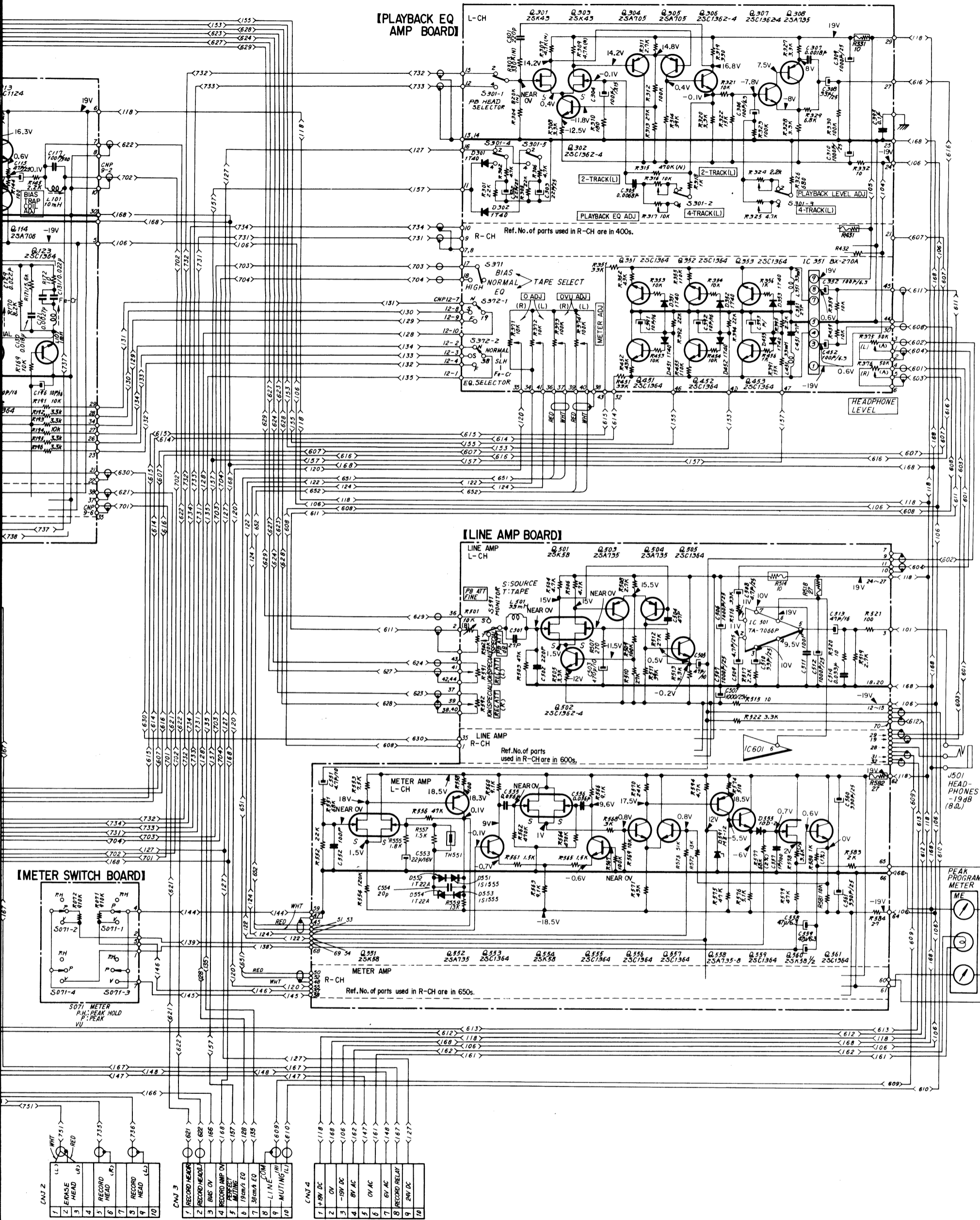

5-3. SCHEMATIC DIAGRAM SYSTEM CONTROL SECTION

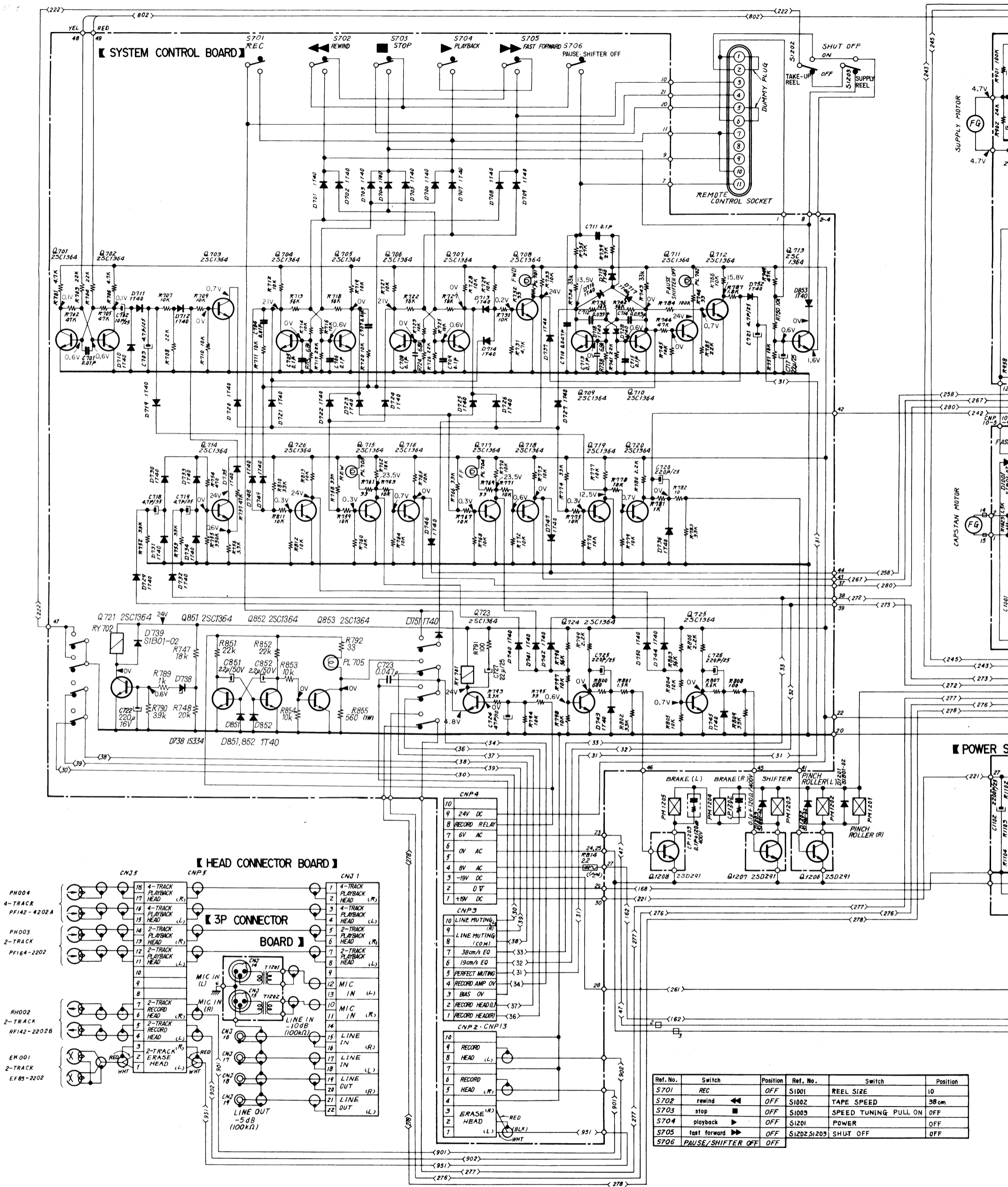

Ref. No.	Switch	Position	Ref. No.	Switch	Position
S701	REC	OFF	S1001	REEL SIZE	10
S702	rewind	OFF	S1002	TAPE SPEED	38 cm
S703	stop	OFF	S1003	SPEED TUNING PULL ON	OFF
S704	playback	OFF	S1201	POWER	OFF
S705	fast forward	OFF	S1202, S1203	SHUT OFF	OFF
S706	PAUSE/SHIFTER OFF	OFF			

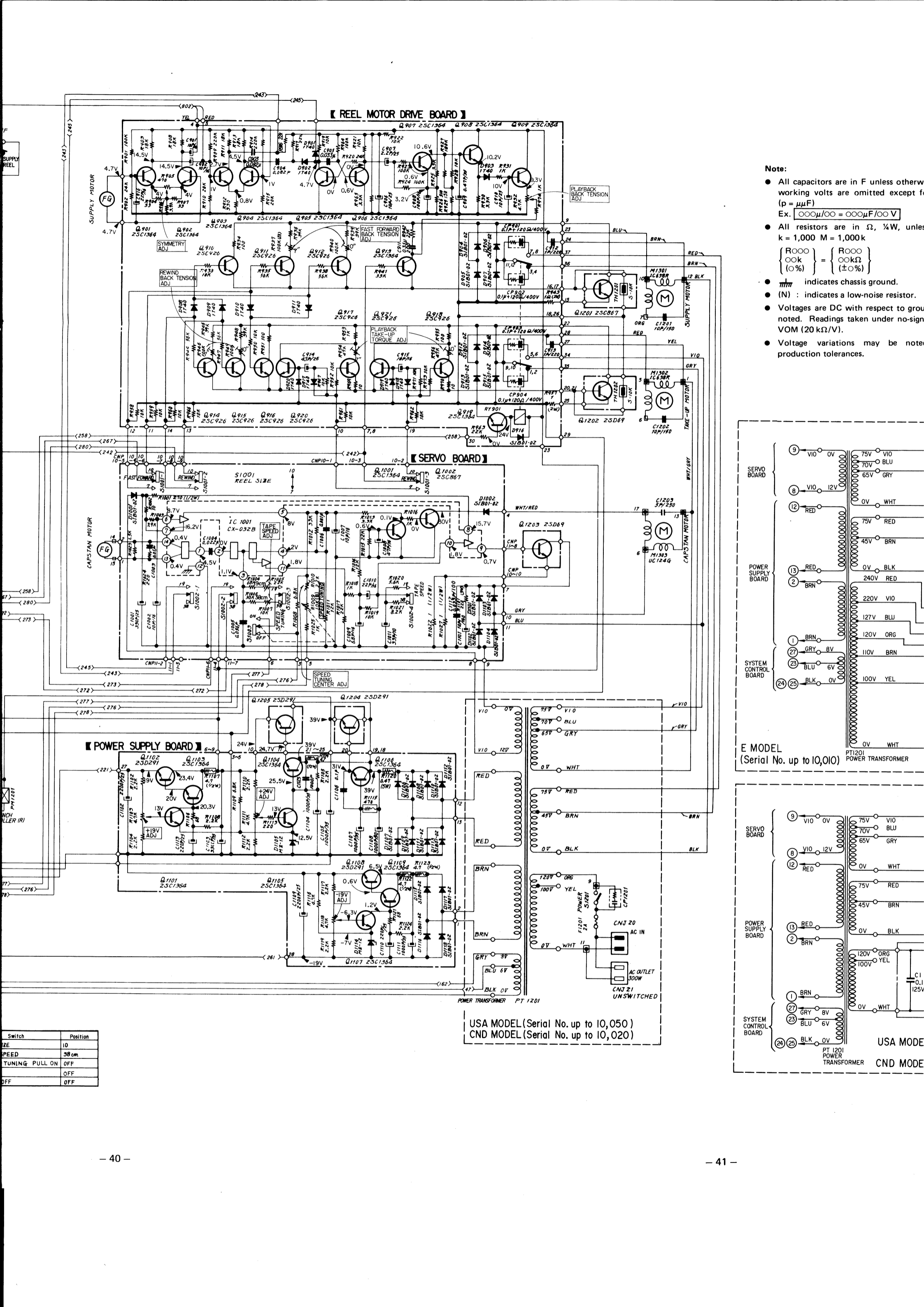

Note:

- All capacitors are in F unless otherwise noted. Working volts are omitted except for electrolytic capacitors (e.g., 100μF/100V).
- All resistors are in Ω, ¼W, unless otherwise noted. k = 1,000, M = 1,000,000.
- R000 = R000Ω, 00k = 00kΩ, (0%) = (±0%).
- --- indicates chassis ground.
- (N) : indicates a low-noise resistor.
- Voltages are DC with respect to ground unless otherwise noted. Readings taken under no-signal conditions (VOM 20kΩ/V).
- Voltage variations may be noted due to production tolerances.

Switch	Position
REEL	10
REWIND	38cm
TUNING PULL ON	OFF
TUNING PULL OFF	OFF
REWIND	OFF
REWIND	OFF

USA MODEL (Serial No. up to 10,050)
 CND MODEL (Serial No. up to 10,020)

Note:

- All capacitors are in F unless otherwise noted. 50 or less working volts are omitted except for electrolytic type. ($p = \mu\mu F$)
Ex. $\frac{000\mu}{00} = 000\mu F / 00 V$
- All resistors are in Ω , $\frac{1}{4}W$, unless otherwise noted.
 $k = 1,000$ $M = 1,000k$
 $\left\{ \begin{matrix} R000 \\ 00k \\ (0\%) \end{matrix} \right\} = \left\{ \begin{matrix} R000 \\ 00k\Omega \\ (\pm 0\%) \end{matrix} \right\}$
- $\text{---} \text{---} \text{---}$ indicates chassis ground.
- (N) : indicates a low-noise resistor.
- Voltages are DC with respect to ground unless otherwise noted. Readings taken under no-signal conditions with a VOM (20 $k\Omega/V$).
- Voltage variations may be noted due to normal production tolerances.

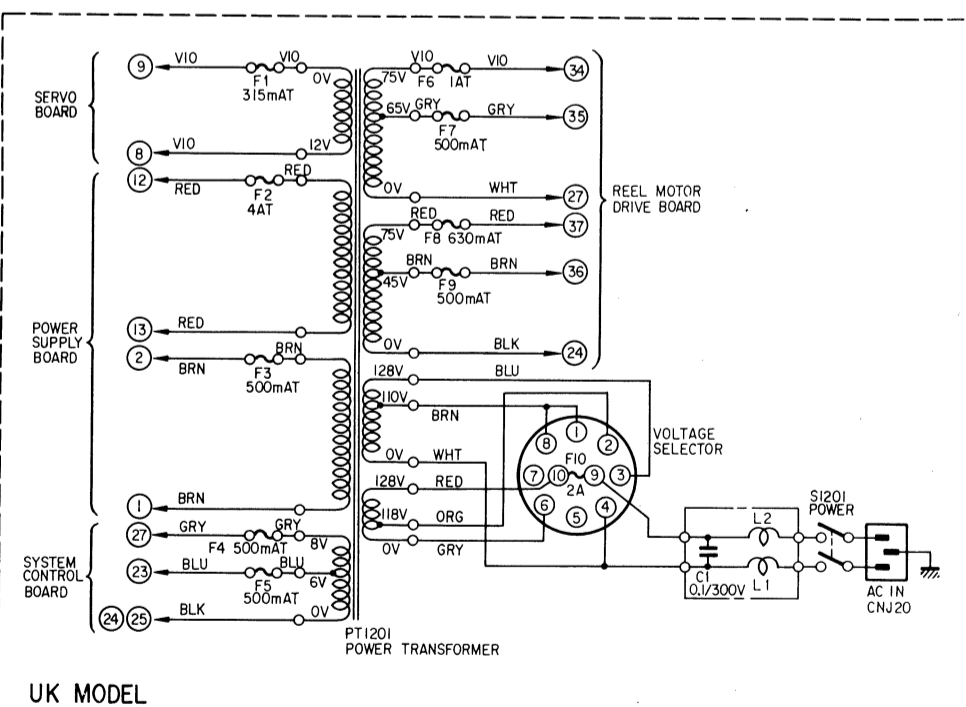
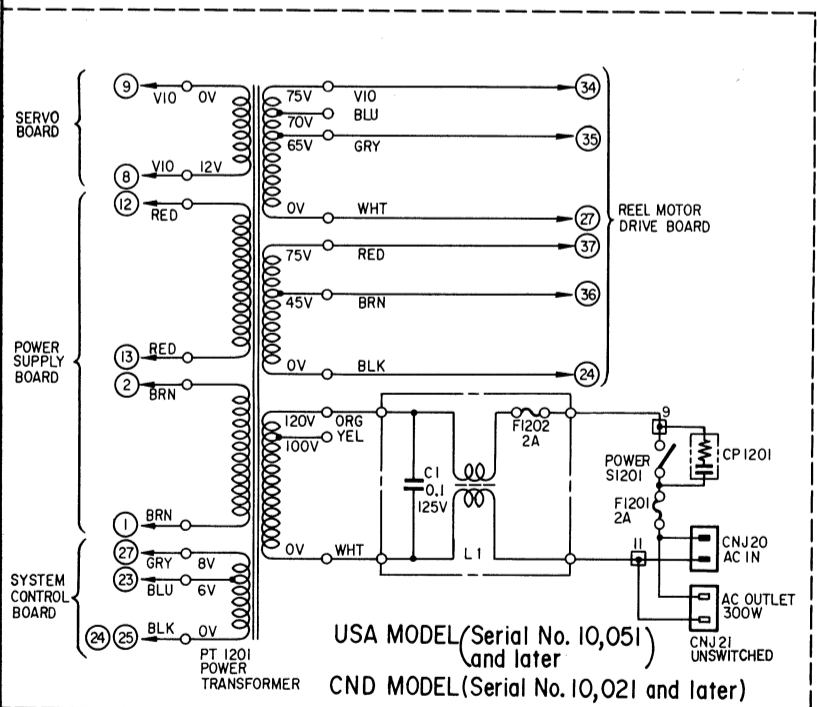
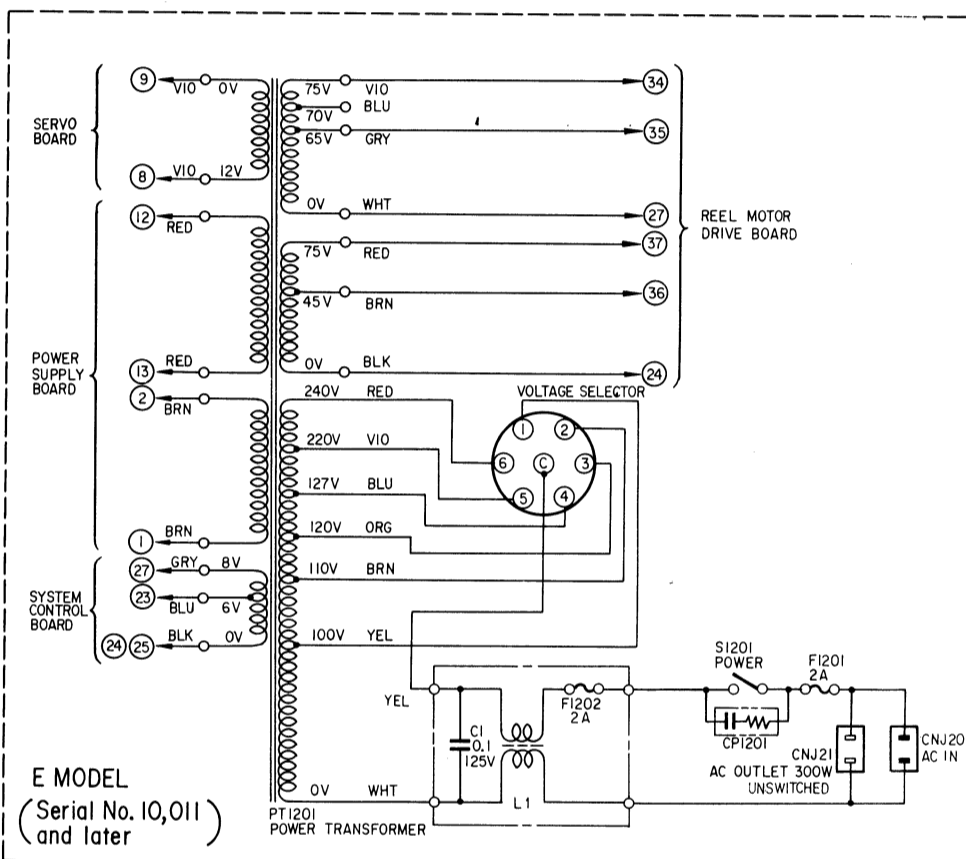
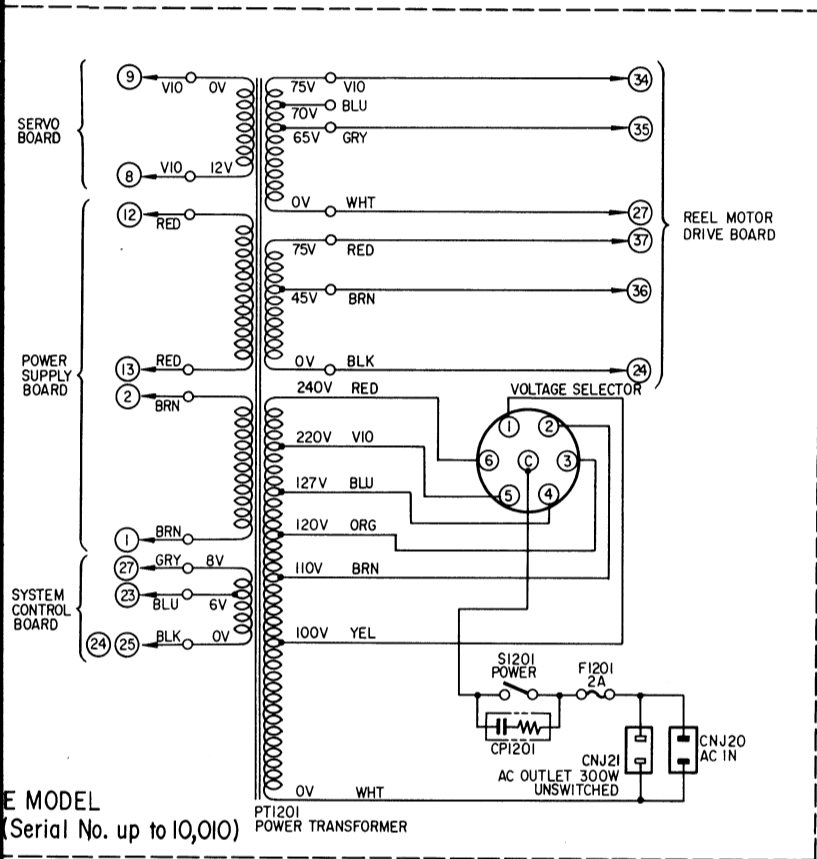

5-4. MOUNTING DIAGRAM SYSTEM CONTROL SECTION (1)

Q701 ~ 721, 723 ~ 726
Q851 ~ 853: 2SC1364

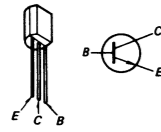

D701 ~ 737, 740 ~ 752
D851 ~ 853: 1T40

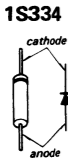

D738: 1S334

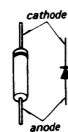

D739: 6X4

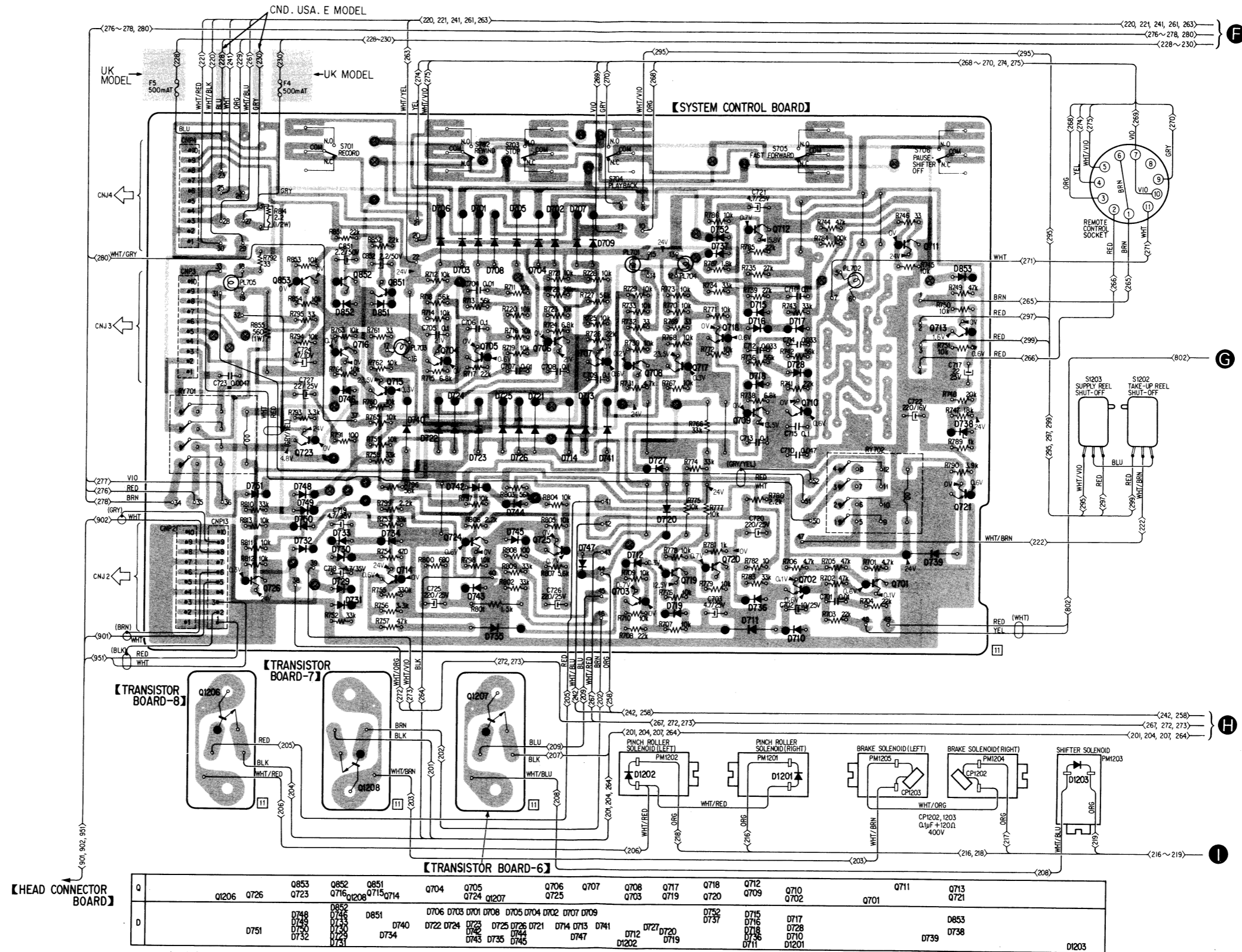

Note:

- All capacitors are in μF unless otherwise noted. 50 or less working volts are omitted except for electrolytic type. $p = \mu\mu F$.
- Color in () indicates color of sleeving over the end portion of shielded wire.

- \otimes = Patterns on the conductor and the component sides are connected at this point.
- : component side pattern
- : conductor side pattern

(2) USA Model (Serial No. up to 10,050)
 Canada Model (Serial No. up to 10,020)
 E Model (Serial No. up to 10,010)

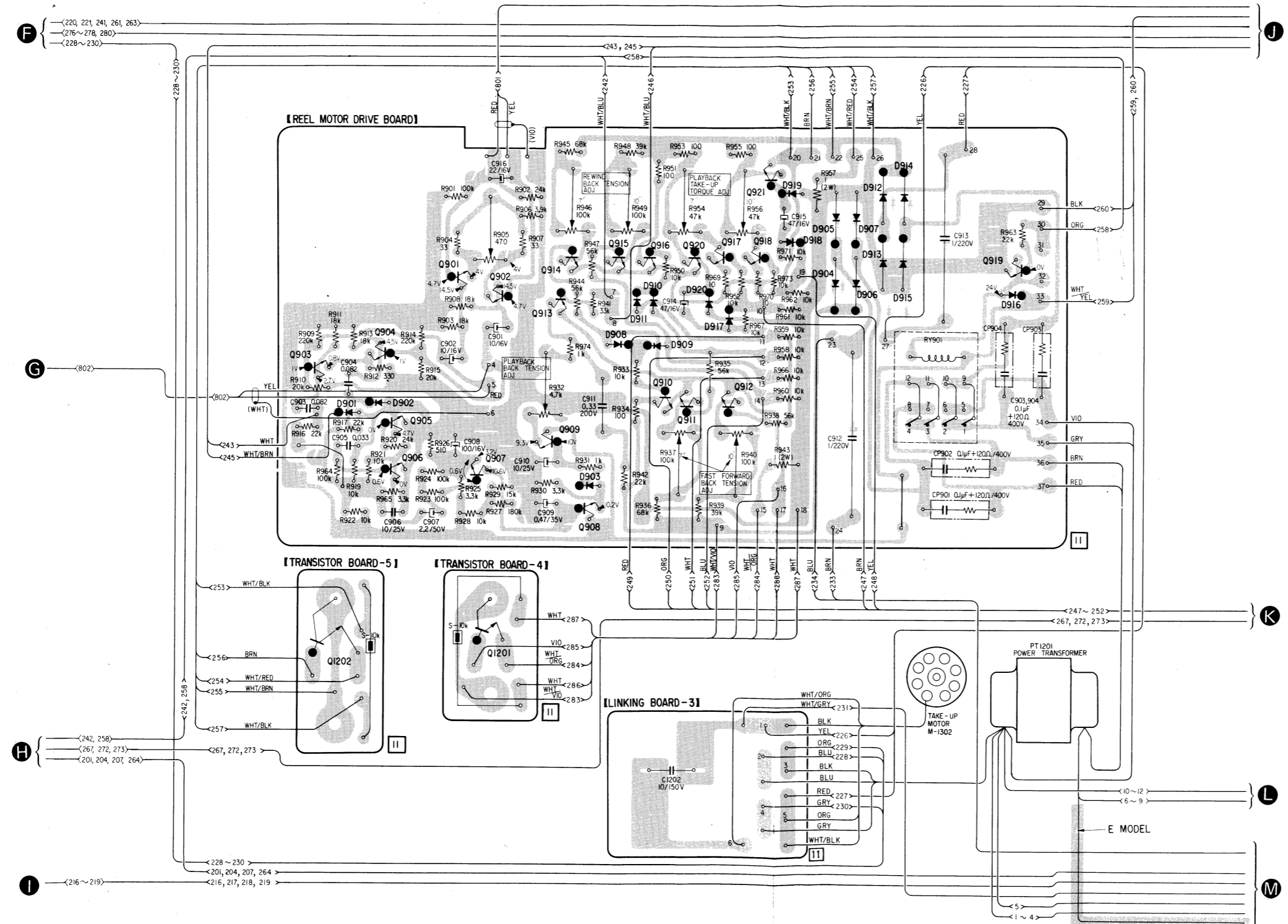

Q901 ~ 909, 913, 919: 2SC1364

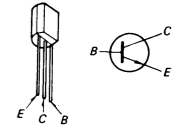

Q910 ~ 912, 914 ~ 918
 Q920, 921: 2SC926

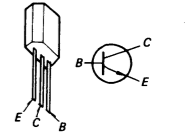

D901 ~ 903, 908 ~ 911
 D917 ~ 920: 1T40

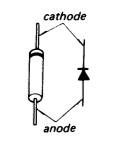

D904 ~ 907, 912 ~ 916: S1B01-02

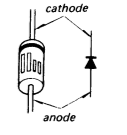

Q	Q903	Q1202	Q904	Q905	Q906	Q901	Q902	Q1201	Q909	Q914	Q908	Q915	Q916	Q910	Q920	Q917	Q912	Q918	Q921	Q919				
D			D901	D902							D903	D908	D911	D910	D909	D920	D917	D919	D905	D907	D912	D914	D915	D916

Note:
 • All capacitors are in μF unless otherwise noted. 50 or less working volts are omitted except for electrolytic type. $p = \mu\text{F}$.
 • Color in () indicates color of sleeving over the end portion of shielded wire.

- (2) **USA Model (Serial No. 10,051 and later)**
Canada Model (Serial No. 10,021 and later)
E Model (Serial No. 10,011 and later)
UK Model

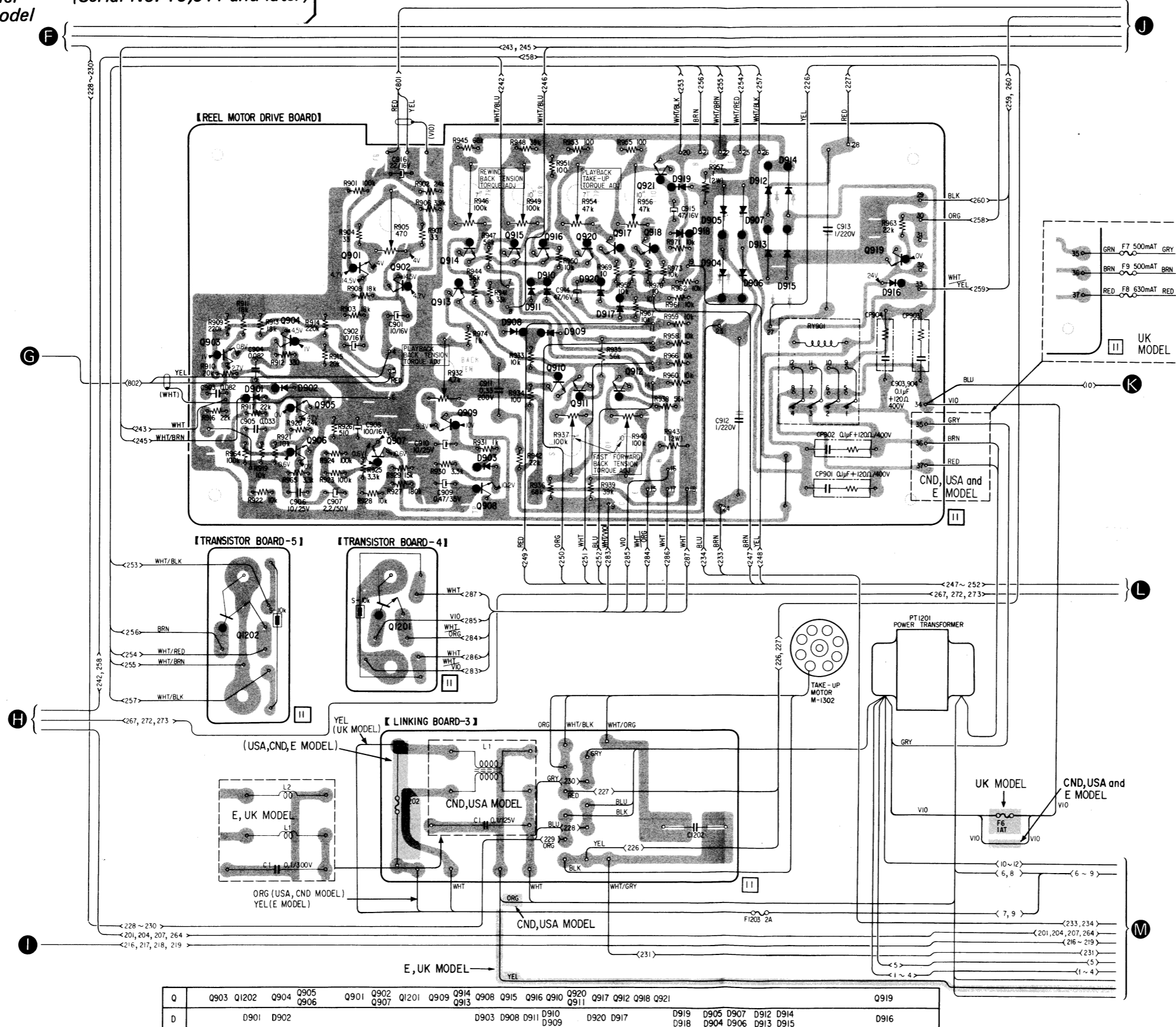

Q901 ~ 909, 913, 919: 2SC1364

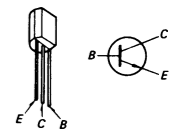

Q910 ~ 912, 914 ~ 918
 Q920, 921: 2SC926

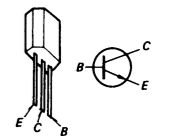

D901 ~ 903, 908 ~ 911
 D917 ~ 920: 1T40

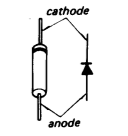

D904 ~ 907, 912 ~ 916: SIB01-02

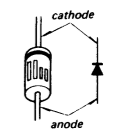

Note:

- All capacitors are in μF unless otherwise noted. 50 or less working volts are omitted except for electrolytic type. $\rho = \mu\mu\text{F}$.
- Color in () indicates color of sleeving over the end portion of shielded wire.

Q	Q903	Q1202	Q904	Q905	Q906	Q901	Q902	Q1201	Q909	Q914	Q908	Q915	Q916	Q910	Q920	Q917	Q912	Q918	Q921	Q919			
D	D901	D902									D903	D908	D911	D910	D909	D920	D917	D919	D905	D907	D912	D914	D916

(3) USA Model (Serial No. up to 10,050)
 Canada Model (Serial No. up to 10,020)
 E Model (Serial No. up to 10,010)

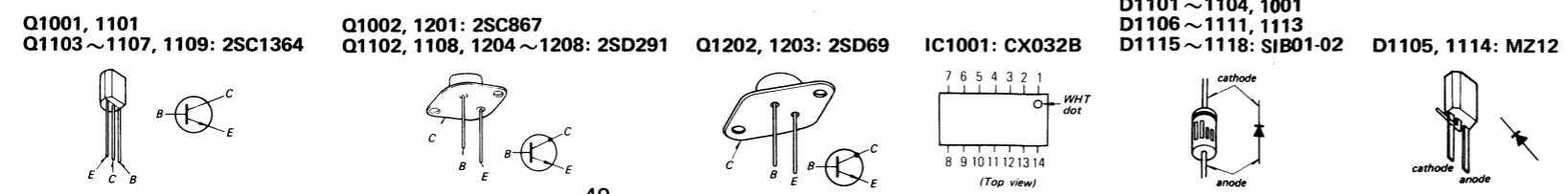
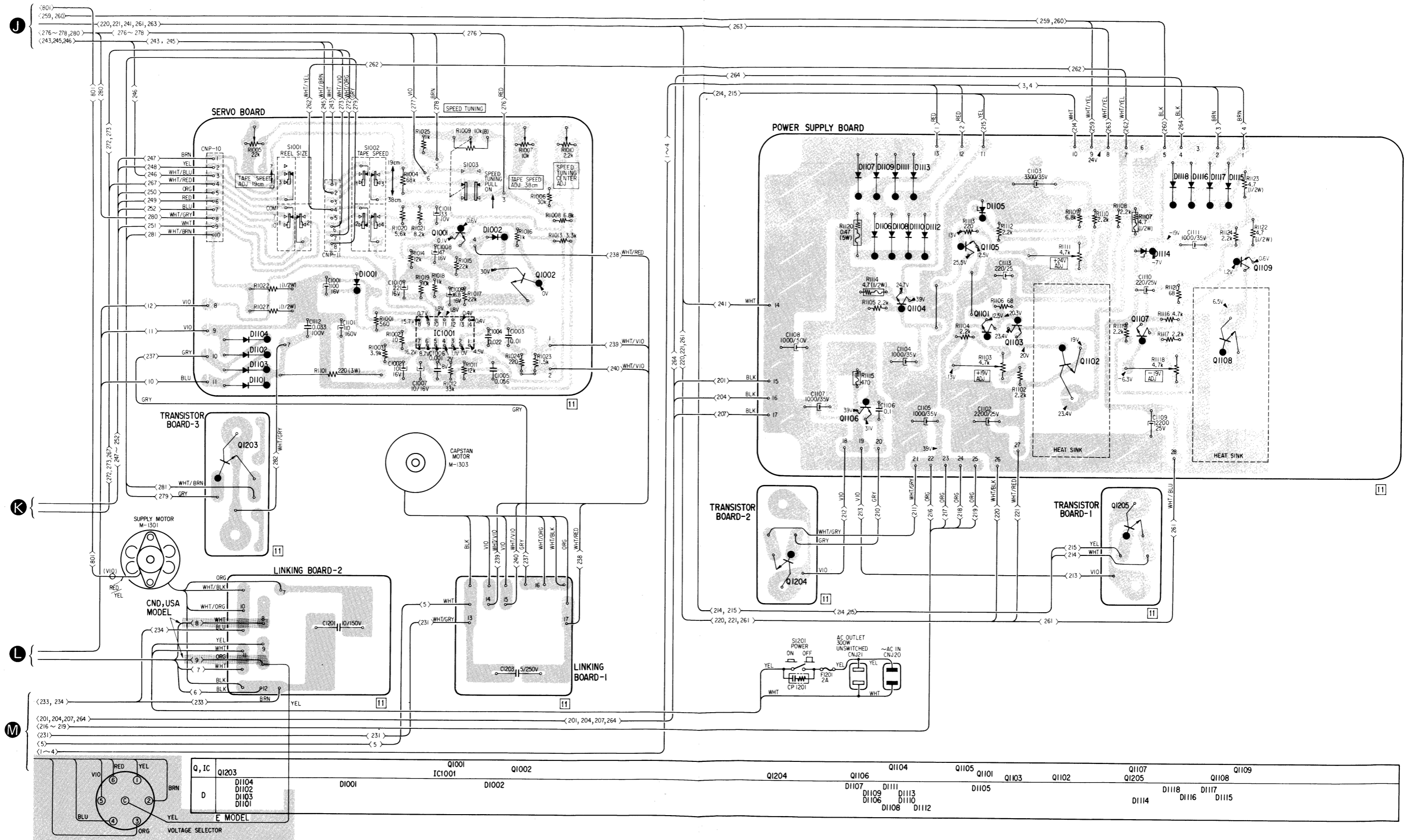

Note:

- All capacitors are in μF unless otherwise noted. 50 or less working volts are omitted except for electrolytic type. $p = \mu\mu\text{F}$.
- Color in () indicates color of sleeving over the end portion of shielded wire.

(3) USA Model (Serial No. 10,051 and later)
 Canada Model (Serial No. 10,021 and later)
 E Model (Serial No. 10,011 and later)
 UK Model

TC-880-2 TC-880-2

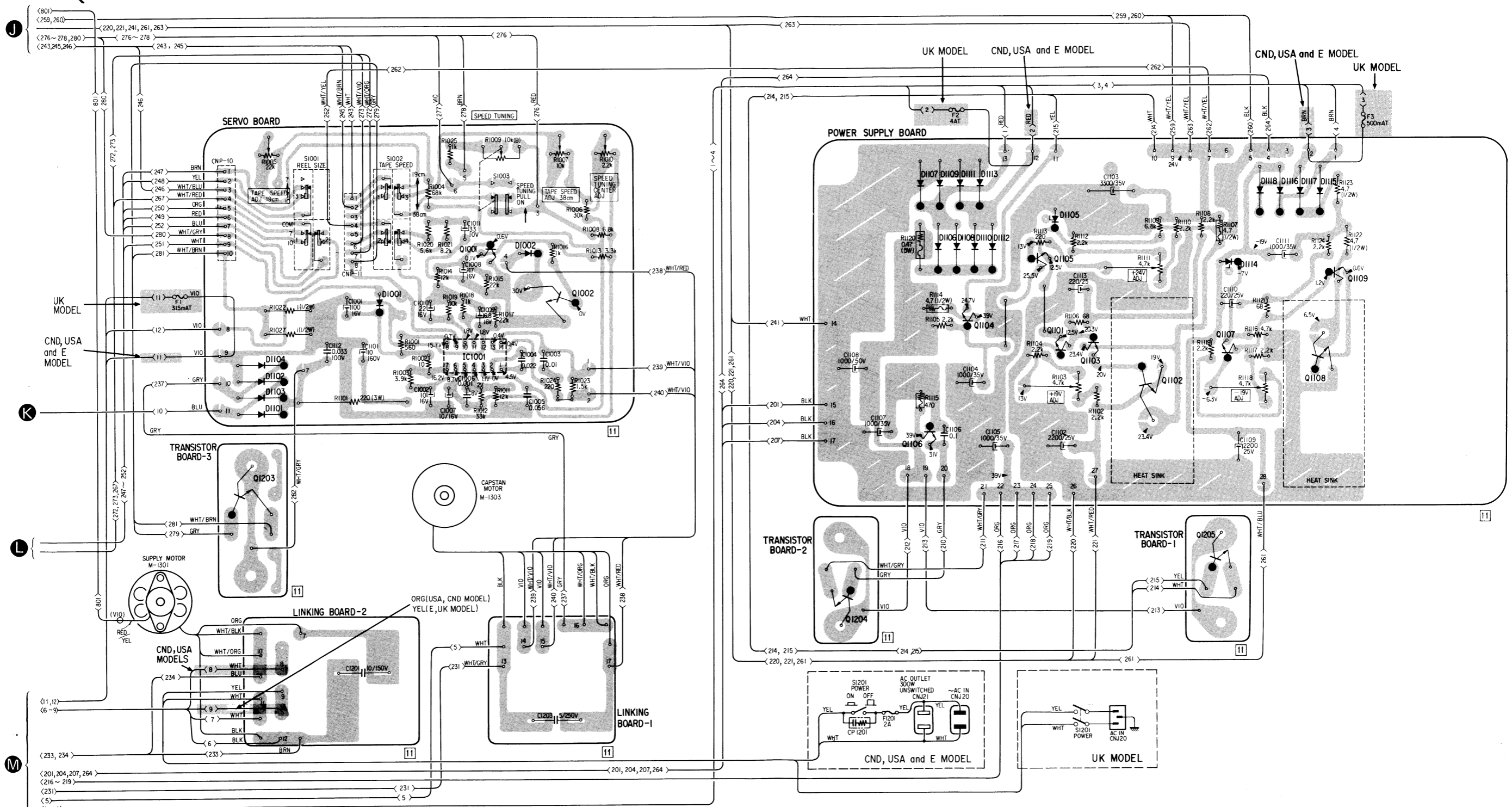

Q, IC	Q1203	Q1001	Q1002	Q1204	Q1106	Q1104	Q1105	Q1101	Q1103	Q1102	Q1107	Q1109
D	D1104 D1102 D1103 D1101	D1001	D1002	D1107 D1109 D1106	D1111 D1113 D1110 D1112	D1115 D1118 D1116 D1115						
	E MODEL											

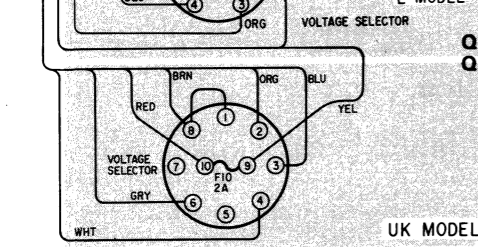

- Q1001, 1101; Q1103 ~ 1107, 1109: 2SC1364
- Q1002, 1201: 2SC867
- Q1102, 1108, 1204 ~ 1208: 2SD291
- Q1202, 1203: 2SD69
- IC1001: CX032B
- D1101 ~ 1104, 1001; D1106 ~ 1111, 1113; D1115 ~ 1118: S1B01-02
- D1105, 1114: MZ12

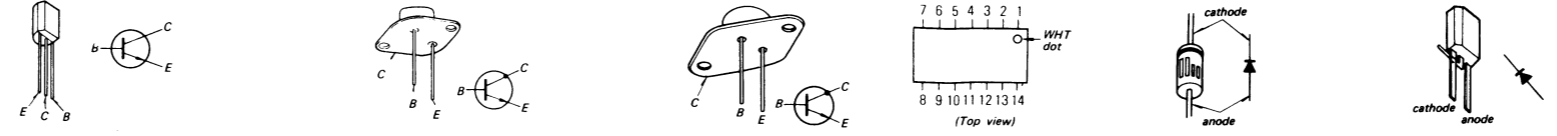

Note:
 • All capacitors are in μF unless otherwise noted. 50 or less working volts are omitted except for electrolytic type. $p = \mu\text{F}$.
 • Color in () indicates color of sleeving over the end portion of shielded wire.

SECTION 6
EXPLODED VIEWS

(1)

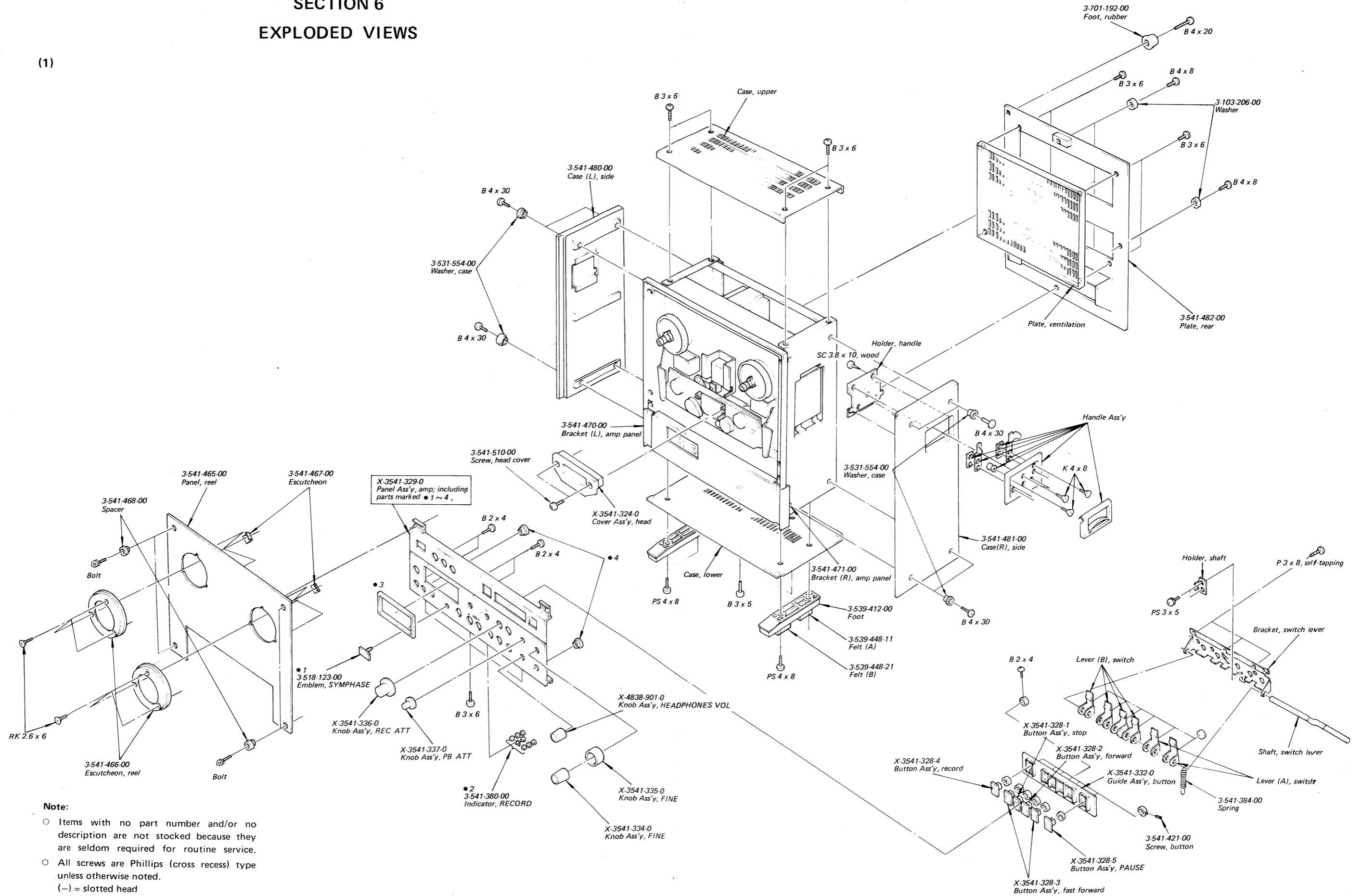

Note:

- Items with no part number and/or no description are not stocked because they are seldom required for routine service.
- All screws are Phillips (cross recess) type unless otherwise noted.
- (-) = slotted head

TC-880-2 TC-880-2

(2)

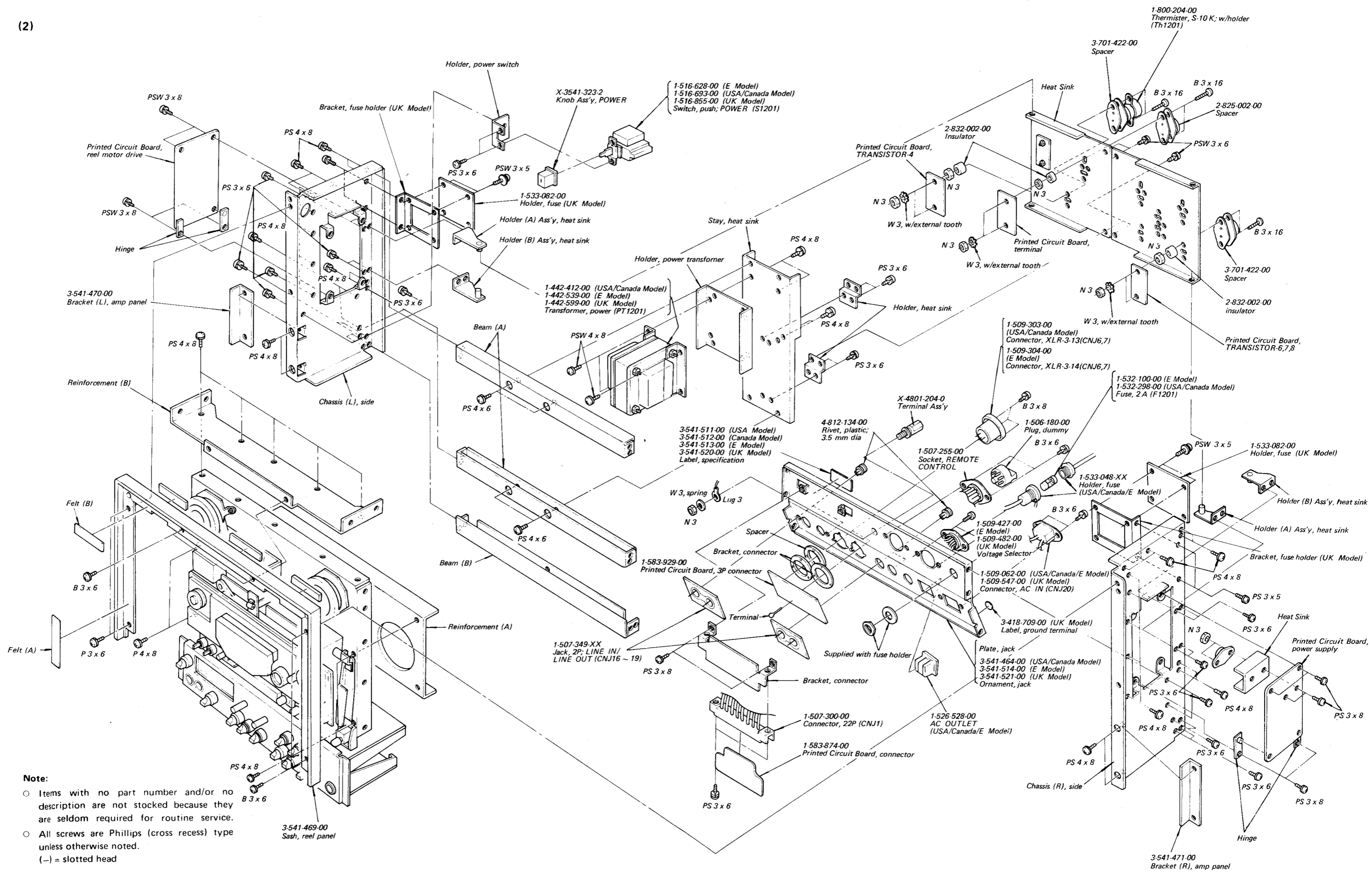

TC-880-2 TC-880-2

(3)

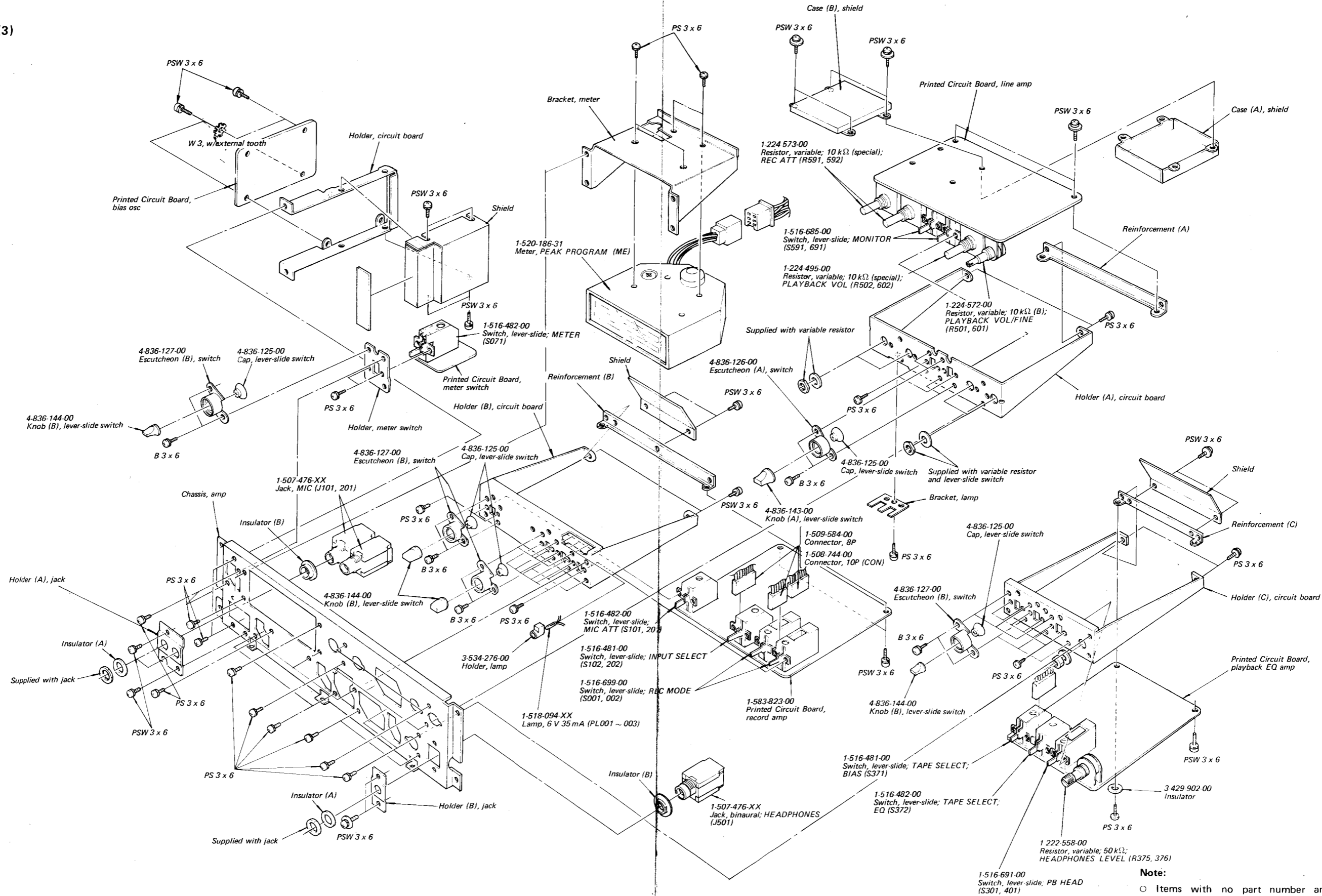

Note:

- Items with no part number and/or no description are not stocked because they are seldom required for routine service.
- All screws are Phillips (cross recess) type unless otherwise noted.
- (-) = slotted head

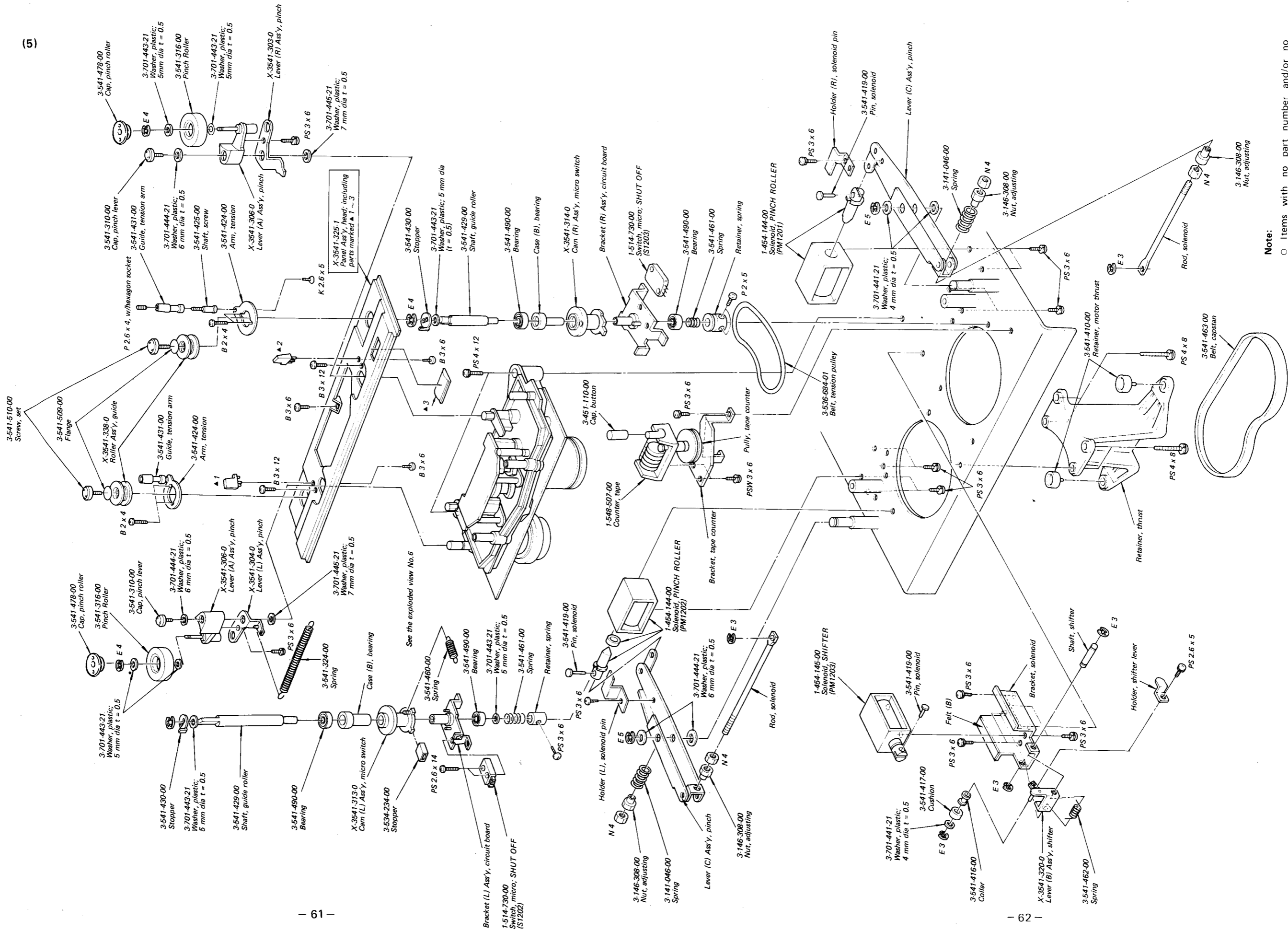

Note:
 ○ Items with no part number and/or no description are not stocked because they are seldom required for routine service.
 ○ All screws are Phillips (cross recess) type unless otherwise noted.
 (—) = slotted head

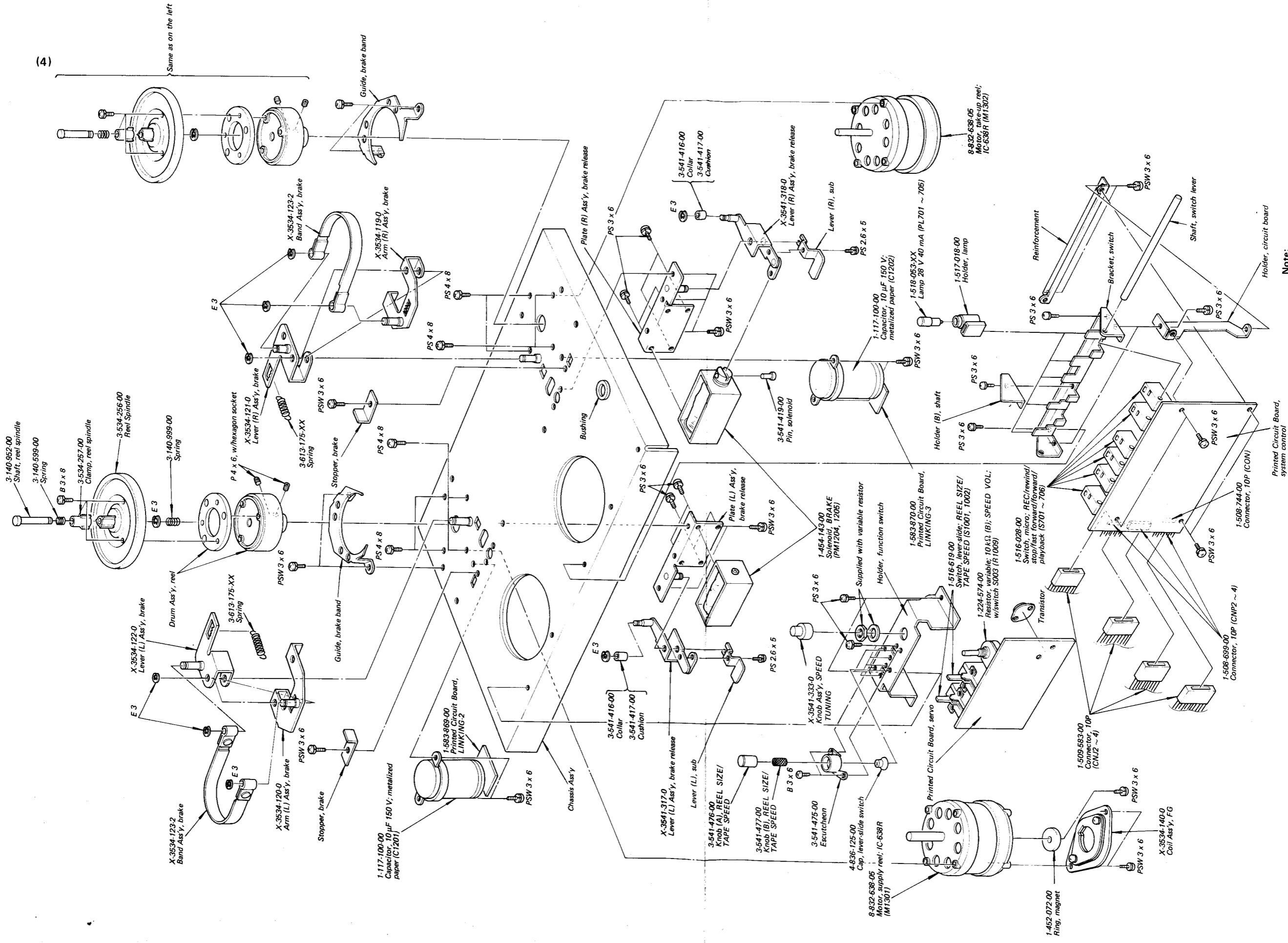

(4)

Same as on the left

Note:

- Items with no part number and/or no description are not stocked because they are seldom required for routine service.
- All screws are Phillips (cross recess) type unless otherwise noted.
- (-) = slotted head

(6)

TC-880-2 TC-880-2

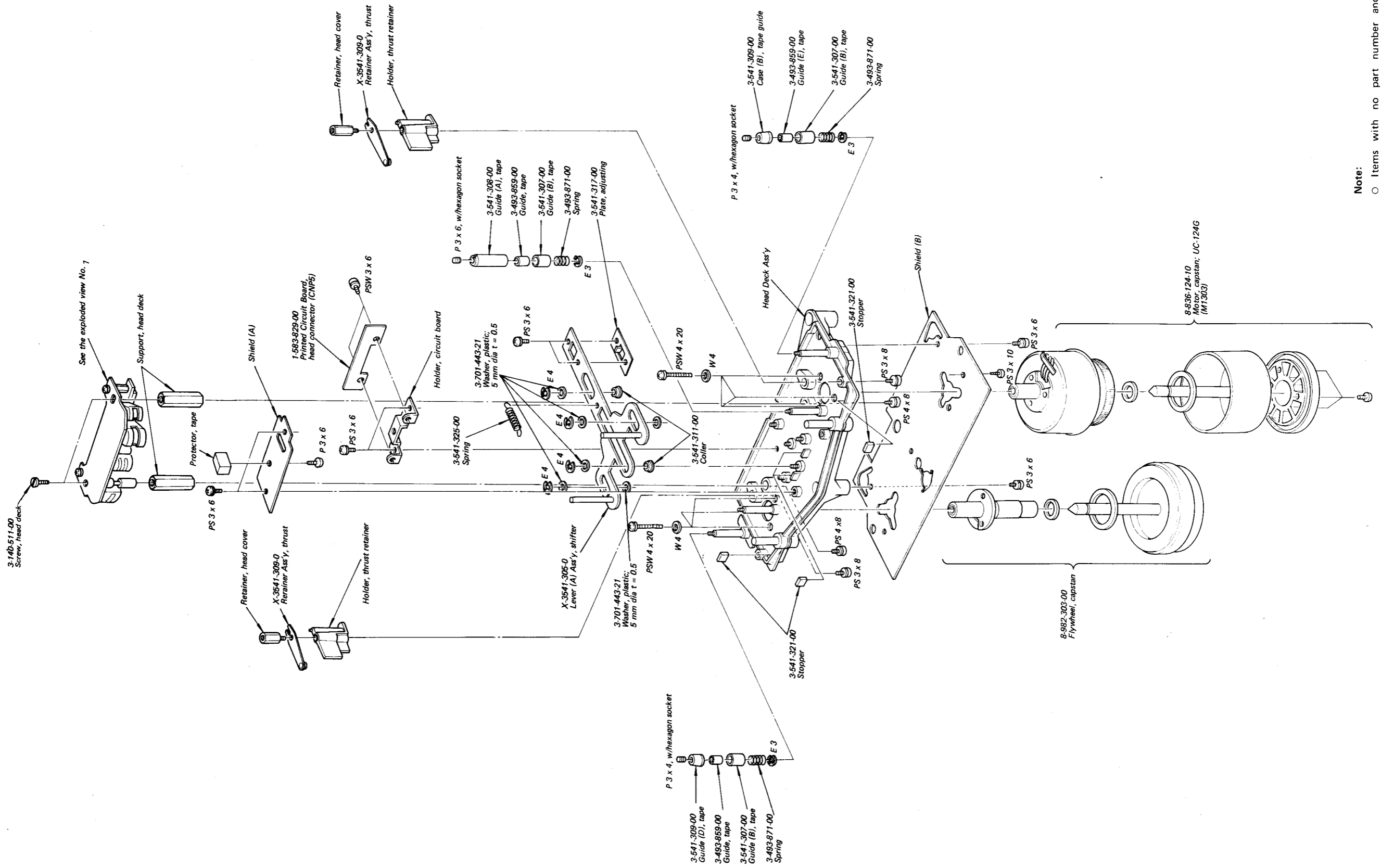

Note:

- Items with no part number and/or no description are not stocked because they are seldom required for routine service.
- All screws are Phillips (cross recess) type unless otherwise noted.
- (-) = slotted head

SECTION 6
PARTS LIST

(7)

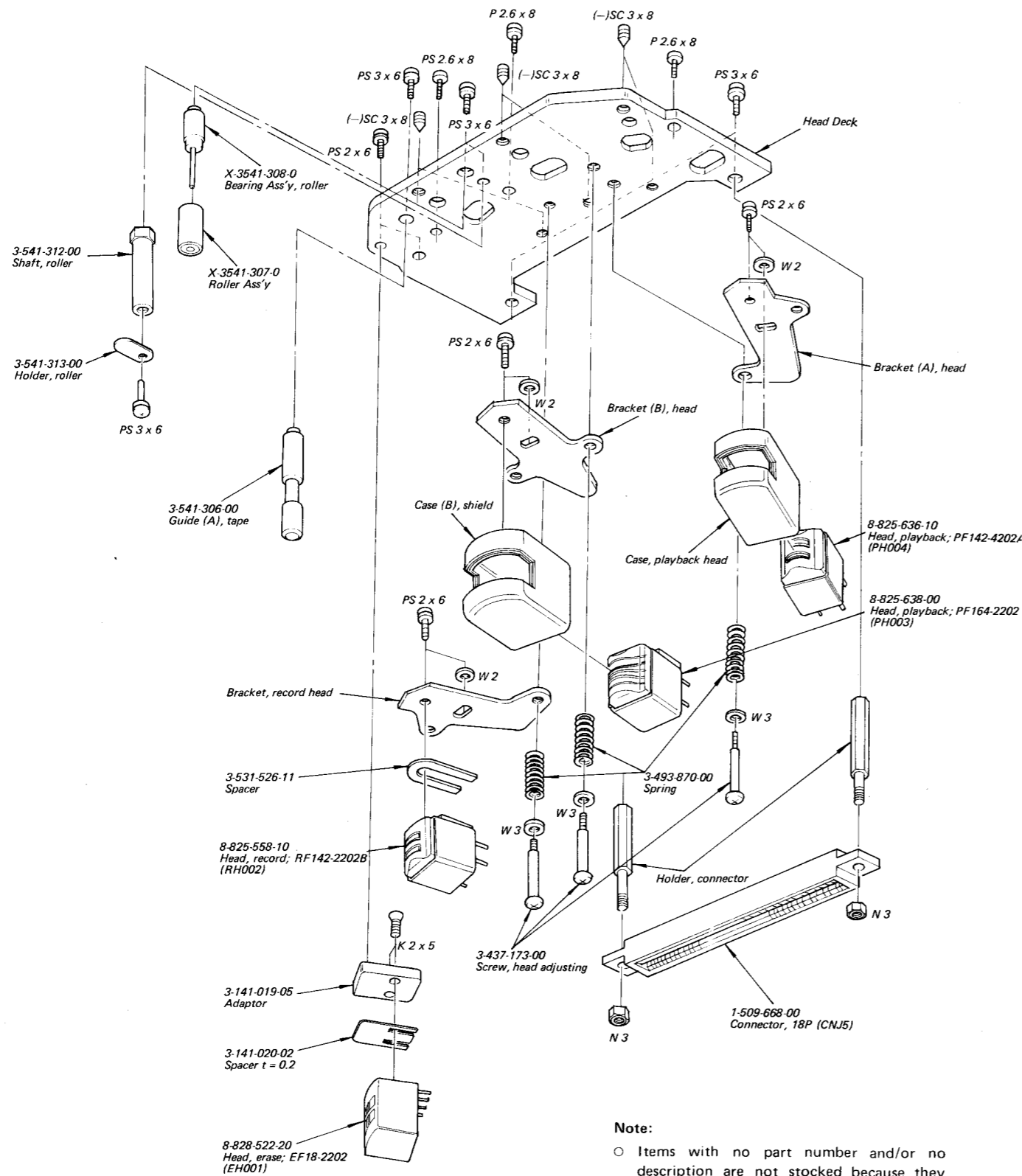

Note:

- Items with no part number and/or no description are not stocked because they are seldom required for routine service.
- All screws are Phillips (cross recess) type unless otherwise noted.
- (-) = slotted head

Ref. No.	Part No.	Description	Ref. No.	Part No.	Description
PRINTED CIRCUIT BOARDS					
1-583-829-00		Head Connector (CNP5)	Q501, 601		2SK58
1-583-869-11		LINKING - 2	Q502, 602		2SC1362-4
1-583-870-11		LINKING-3	Q503, 603		2SA735
		(USA Model Serial No. up to 10,050)	Q504, 604		2SA735
		(Canada Model Serial No. up to 10,020)	Q505, 605		2SC1364
		(E Model Serial No. up to 10,010)	Q551, 651		2SK58
1-584-560-11		LINKING-3	Q552, 652		2SA735
		(USA Model Serial No. 10,051 and later)	Q553, 653		2SC1364
		(Canada Model Serial No. 10,021 and later)	Q554, 654		2SK58
		(E Model Serial No. 10,011 and later)	Q555 ~ 557		2SC1364
		(UK Model)	Q655 ~ 657		2SC1364
1-583-874-11		Connector (CNJ1)	Q558, 658		2SA735
1-583-929-11		3P Connector	Q559, 659		2SC1364
1-583-823-00		Record Amp	Q560		2SK58
SEMICONDUCTORS					
Transistors					
Q101, 201		2SK58	Q701 ~ 721		
Q102, 202		2SC1362-4	Q723 ~ 726		2SC1364
Q103, 203		2SA705	Q851 ~ 853		2SC1364
Q104, 204		2SA705	Q901 ~ 909		2SC1364
Q105, 205		2SC1362-4	Q910 ~ 912		2SC926
Q106, 206		2SK58	Q913		2SC1364
Q107, 207		2SC1362-4	Q914 ~ 918		2SC926
Q108, 208		2SA705	Q919		2SC1364
Q109, 209		2SA705	Q920, 921		2SC926
Q110, 210		2SC1362-4	Q1001		2SC1364
Q111, 211		2SK58	Q1002		2SC867
Q112, 212		2SA735	Q1101		2SC1364
Q113, 213		2SC1124	Q1102		2SD291
Q114, 214		2SA706	Q1103 ~ 1107		2SC1364
Q115 ~ 123		2SC1364	Q1108		2SD291
Q215 ~ 223		2SC1364	Q1109		2SC1364
Q301, 401		2SK43	Q1201		2SC867
Q302, 402		2SC1362-4	Q1202, 1203		2SD69
Q303, 403		2SK43	Q1204 ~ 1208		2SD291
Q304, 404		2SA705	Diodes		
Q305, 405		2SA705	D191 ~ 194		1T40
Q306, 406		2SC1362-4	D301, 302		
Q307, 407		2SA735	D351 ~ 353		1T40
Q308, 408		2SA735	D451 ~ 453		
Q351 ~ 353		2SC1364			
Q451 ~ 453		2SC1364			

Ref. No. Part No. Description

D551, 651		1S1555
D552, 652		1T22A
D553, 653		1S1555
D554, 654		1T22A
D555, 655		10D2
D591		MZ12
D701 ~ 737		1T40
D738		1S334
D739		SIB01-02
D740 ~ 752		1T40
D851 ~ 853		1T40
D901 ~ 903		1T40
D904 ~ 907		SIB01-02
D908 ~ 911		1T40
D912 ~ 916		SIB01-02
D917 ~ 920		1T40
D1001, 1002		SIB01-02
D1101 ~ 1104		SIB01-02
D1105		MZ12
D1106 ~ 1113		SIB01-02
D1114		MZ12
D1115 ~ 1118		SIB01-02

Integrated Circuits

IC001		TA7122AP
IC351		BX270A
IC501, 601		TA7066P
IC1001		CX032B

Thermistors

Th551, 651	1-800-349-00	270Ω	
Th1201	1-800-204-00	S-10K	(w/holder)
Th1202	1-800-202-XX	S-10K	(w/holder)

COILS & TRANSFORMERS

Coils

L1, L2	1-407-591-00	Inductor (UK Model)
L1	1-421-225-11	Inductor
		(E Model Serial No. 10, 011 and later)
		Inductor
	1-421-302-22	(USA Model Serial No. 10,051 and later)
		(Canada Model Serial No. 10,021 and later)

Ref. No. Part No. Description

L051, 052	1-407-284-00	Variable inductor, 1 mH
L101, 201	1-407-290-11	Variable inductor, 10 mH
L102 ~ 104	1-407-268-11	Variable inductor, 1.5 mH
L202 ~ 204		
L105, 205	1-407-269-11	Variable inductor, 2.2 mH
L106, 206	1-407-268-11	Variable inductor, 1.5 mH
L107, 207	1-407-267-11	Variable inductor, 1.0 mH
L351, 451	1-407-212-XX	Microinductor, 33 mH
L501, 601	1-407-561-00	Microinductor, 33 mH

Transformers

T1201,1202	1-423-205-00	Input
PT1201	1-442-412-00	Power (USA/Canada Model)
	1-442-539-00	Power (E Model)
	1-442-599-00	Power (UK Model)

CAPACITORS

All capacitors are in μF unless otherwise indicated. 50 or less working volts are omitted except for electrolytic type.
(elect = electrolytic, p = $\mu\mu\text{F}$)

C1	1-108-747-11	0.1	125 V	mylar	(USA Model Serial No. 10,051 and later)	(Canada Model Serial No. 10,021 and later)	(E Model Serial No. 10,011 and later)					
								1-108-747-22	0.1	300 V	mylar	(UK Model)
C001	1-121-416-11	100	25 V	elect								
C002	1-131-236-61	1		solid tantalum								
C003	1-108-599-12	0.068		mylar								
C004	1-108-559-12	0.0015		mylar								
C005	1-108-561-12	0.0018		mylar								
C006	1-102-973-11	100 p		ceramic								
C007	1-121-395-11	4.7	25 V	elect								
C051	1-121-398-11	10	25 V	elect								
C052	1-129-703-11	0.0012	630 V	polypropylene								
C053	1-107-183-11	390 p		silvered mica								
C054,055	1-141-034-21	20 ~ 120 p		trimmer								
C056	1-107-183-11	390 p		silvered mica								
C057,058	1-107-157-11	270 p	500 V	silvered mica								
C101,201	1-121-424-11	470	6.3 V	elect								
C102,202	1-101-880-11	47 p		ceramic								
C103,203	1-121-413-11	100	6.3 V	elect								
C104,204	1-121-654-11	330	25 V	elect								
C105,205												

<u>Ref. No.</u>	<u>Part No.</u>	<u>Description</u>	
C106,206	1-121-424-11	470	6.3 V elect
C107,207	1-101-880-11	47 p	ceramic
C108,208	1-121-413-11	100	6.3 V elect
C109,209 C110,210	1-121-416-11	100	25 V elect
C111,211	1-108-603-12	0.1	mylar
C112,212	1-121-424-11	470	6.3 V elect
C113,213	1-121-654-11	330	25 V elect
C114,214	1-121-419-11	220	6.3 V elect
C115,215	1-121-410-11	47	25 V elect
C117,217	1-107-169-11	100 p	500 V silvered mica
C118,218 C119,219	1-108-555-12	0.001	mylar
C120,220	1-108-557-12	0.0012	mylar
C121,221	1-108-565-12	0.0027	mylar
C122,222	1-108-563-12	0.0022	mylar
C124,224	1-108-583-12	0.015	mylar
C125,225	1-108-581-12	0.012	mylar
C126,226	1-108-585-12	0.018	mylar
C127,227	1-108-581-12	0.012	mylar
C128,228	1-108-591-12	0.033	mylar
C129,229	1-108-587-12	0.022	mylar
C130,230	1-108-585-12	0.018	mylar
C131,231	1-108-587-12	0.022	mylar
C132,232	1-121-391-11	1	50 V elect
C191~196	1-121-651-11	10	16 V elect
C197	1-108-603-12	0.1	mylar
C301,401	1-107-093-11	220 p	silvered mica
C302,303	1-121-480-11	22	25 V elect
C304,404	1-131-187-61	100	solid tantalum
C305,405	1-108-575-12	0.0068	mylar
C306,406	1-121-413-11	100	6.3 V elect
C307,407	1-108-561-12	0.0018	mylar
C308,408	1-121-404-11	33	25 V elect
C309,409 C310,410	1-121-657-11	1000	25 V elect
C351,451	1-107-071-11	27 p	silvered mica
C352,452	1-121-413-11	100	6.3 V elect
C391~393	1-121-651-11	10	16 V elect
C395	1-108-603-12	0.1	mylar

<u>Ref. No.</u>	<u>Part No.</u>	<u>Description</u>	
C501,601	1-107-071-11	27 p	silvered mica
C502,602	1-107-093-11	220 p	silvered mica
C503,603	1-121-425-11	470	10 V elect
C504,604	1-101-880-11	47 p	ceramic
C505,605	1-121-352-11	47	10 V elect
C506,507	1-121-657-11	1000	25 V elect
C508,608 C509,609	1-121-395-11	4.7	25 V elect
C510,610	1-121-404-11	33	25 V elect
C511,611	1-102-973-11	100 p	ceramic
C512	1-121-657-11	1000	25 V elect
C513,613	1-121-409-11	47	16 V elect
C514,614	1-108-244-12	0.033	mylar
C551,651	1-131-192-61	4.7	solid tantalum
C552,652	1-102-973-11	100 p	ceramic
C553,653	1-131-201-61	22	solid tantalum
C554,654	1-102-958-11	20 p	ceramic
C555,655 C556,656	1-108-361-12	0.056	mylar
C557,657	1-130-005-11	1	100 V metalized paper
C558,658 C559,659	1-131-191-61	47	solid tantalum
C560,561	1-121-654-11	330	25 V elect
C701	1-108-579-12	0.01	mylar
C702	1-121-398-11	10	25 V elect
C703	1-121-395-11	4.7	25 V elect
C704	1-108-579-12	0.01	mylar
C705,706	1-108-603-12	0.1	mylar
C707	1-108-579-12	0.01	mylar
C708,709	1-108-603-12	0.1	mylar
C710	1-108-595-12	0.047	mylar
C711	1-108-603-12	0.1	mylar
C712	1-108-591-12	0.033	mylar
C713	1-108-603-12	0.1	mylar
C714	1-108-591-12	0.033	mylar
C715	1-108-603-12	0.1	mylar
C717	1-121-480-11	22	25 V elect
C718,719	1-131-219-61	4.7	solid tantalum
C720	1-121-422-11	220	25 V elect
C721	1-121-395-11	4.7	25 V elect

<u>Ref. No.</u>	<u>Part No.</u>	<u>Description</u>	
C722	1-121-421-11	220	16 V elect
C723	1-108-595-12	0.047	mylar
C724	1-121-352-11	47	10 V elect
C725,726	1-121-422-11	220	25 V elect
C727	1-121-480-11	22	25 V elect
C851,852	1-121-450-11	2.2	50 V elect
C901,902	1-121-651-11	10	16 V elect
C903,904	1-108-601-12	0.082	mylar
C905	1-108-591-12	0.033	mylar
C906	1-121-398-11	10	25 V elect
C907	1-121-450-11	2.2	50 V elect
C908	1-121-415-11	100	16 V elect
C909	1-131-213-61	0.47	solid tantalum
C910	1-121-398-11	10	25 V elect
C911	1-105-771-13	0.33	200 V mylar
C912,913	1-113-072-11	1	AC200 V metalized paper
C914	1-121-395-11	4.7	25 V elect
C915	1-121-651-11	10	16 V elect
C916	1-121-479-11	22	16 V elect
C1001	1-121-654-11	330	25 V elect
C1002	1-121-651-11	10	16 V elect
C1003	1-108-579-12	0.01	mylar
C1004	1-108-587-12	0.022	mylar
C1005	1-108-597-12	0.056	mylar
C1006	1-108-555-12	0.001	mylar
C1007	1-121-651-11	10	16 V elect
C1008	1-121-409-11	47	16 V elect
C1009	1-131-198-61	6,8	16 V solid tantalum
C1010	1-131-201-61	22	16 V solid tantalum
C1011	1-131-195-61	33	10 V solid tantalum
C1101	1-121-999-11	10	160 V elect
C1102	1-123-047-11	2200	25 V elect
C1103	1-123-118-11	3300	35 V elect
C1104,1105	1-121-388-11	1000	35 V elect
C1106	1-108-603-12	0.1	mylar
C1107	1-121-388-11	1000	35 V elect
C1108	1-123-046-11	1000	50 V elect
C1109	1-123-047-11	2200	25 V elect
C1110	1-121-422-11	220	25 V elect

<u>Ref. No.</u>	<u>Part No.</u>	<u>Description</u>	
C1111	1-121-388-11	1000	35 V elect
C1112	1-108-427-12	0.033	200 V mylar
C1113	1-121-422-11	220	25 V elect
C1125	1-101-001-11	1000 p	ceramic
C1201,1202	1-117-100-00	10	150 V metalized paper
C1203	1-117-101-00	5	250 V metalized paper

RESISTORS

All resistors are in ohms. Regular type $\frac{1}{4}W \pm 5\%$ carbon and composition resistors except special type are omitted. Check schematic diagram for the resistance values.

k = 1,000, M = 1000 k

R004	1-242-727-09	180 k	$\frac{1}{4} W$	low noise
R005	1-242-721-09	100 k	$\frac{1}{4} W$	low noise
R006	1-242-713-09	47 k	$\frac{1}{4} W$	low noise
R008,009	1-224-645-XX	10 k		adjustable
R051	1-217-399-00	100	$\frac{1}{4} W$	fuse
R104,204	1-242-721-09	100 k	$\frac{1}{4} W$	low noise
R105,205 R107,207	1-242-689-09	4.7 k	$\frac{1}{4} W$	low noise
R108,208	1-224-642-XX	1 k		adjustable
R115,215	1-242-720-09	91 k	$\frac{1}{4} W$	low noise
R117,217	1-217-399-11	100	$\frac{1}{4} W$	fuse
R119,219	1-242-721-09	100 k	$\frac{1}{4} W$	low noise
R120,220 R122,222	1-242-689-09	4.7 k	$\frac{1}{4} W$	low noise
R130,230 R132,232	1-224-646-XX	22 k		adjustable
R148,248 R151,251 R154,254	1-222-777-00	100 k		adjustable
R303,403	1-242-733-09	330 k	$\frac{1}{4} W$	low noise
R304,404	1-242-743-09	820 k	$\frac{1}{4} W$	low noise
R307,407 R309,409	1-242-689-09	4.7 k	$\frac{1}{4} W$	low noise
R315,415	1-242-737-09	470 k	$\frac{1}{4} W$	low noise
R316,416 R317,417	1-224-774-00	10 k		adjustable
R324,424	1-224-643-XX	2.2 k		adjustable
R325,425	1-224-644-XX	4.7 k		adjustable
R331,431	1-217-387-11	10	$\frac{1}{4} W$	fuse
R371,372	1-224-252-XX	10 k		adjustable

<u>Ref. No.</u>	<u>Part No.</u>	<u>Description</u>	
R373,374	1-224-255-XX	100 k	adjustable
R375,376	1-222-558-00	50 k (A), variable;	HEADPHONE LEVEL
R501,601	1-224-572-00	10 k (B), variable;	PLAYBACK FINE
R502,602	1-224-495-00	10 k (Special), variable;	PLAYBACK VOL
R514	1-217-387-11	10	¼ W fuse
R518	1-217-392-11	27	¼ W fuse
R577,677	1-210-856-11	68 k	¼ W ± 2% carbon
R580,680	1-211-913-11	1 k	¼ W ± 1% carbon
R582	1-217-392-11	27	¼ W fuse
R591,592	1-224-573-00	10 k (Special), variable;	REC ATT
R814	1-217-726-11	2.2	½ W fuse
R932	1-222-773-00	4.7 k	adjustable
R905	1-224-641-XX	470	adjustable
R937,940	1-224-648-XX	100 k	adjustable
R943	1-206-439-11	1	2 W metal oxide
R946,949	1-224-648-XX	100 k	adjustable
R954,956	1-224-647-XX	47 k	adjustable
R957	1-206-439-11	1	2 W metal oxide
R974	1-224-642-XX	1 k	2 W adjustable
R1001	1-244-859-11	270	½ W carbon
R1005	1-224-491-11	22 k, adjustable;	metal oxide
R1007	1-224-493-11	10 k	adjustable
R1009	1-224-574-11	10 k (B), variable;	SPEED VOL
R1010	1-224-489-11	2.2 k, adjustable;	metal oxide
R1022,1027	1-244-801-11	1	½ W carbon
R1101	1-206-709-11	220	3 W metal oxide
R1103	1-224-644-XX	4.7 k	adjustable
R1107	1-217-430-11	4.7	½ W fuse
R1109	1-224-489-11	2.2 k, adjustable;	metal oxide
R1111	1-224-644-XX	4.7 k	adjustable
R1114	1-217-430-11	4.7	½ W fuse
R1115	1-217-407-11	470	½ W fuse
R1118	1-244-644-XX	4.7 k	adjustable
R1120	1-217-158-11	0.47	5 W fuse
R1122,1123	1-217-430-11	4.7	½ W fuse

<u>Ref. No.</u>	<u>Part No.</u>	<u>Description</u>	
SWITCHES			
S001,002	1-516-699-00	Lever-slide,	REC MODE
S071	1-516-482-00	Lever-slide,	METER
S101,201	1-516-482-00	Lever-slide,	MIC ATT
S102,202	1-516-481-00	Lever-slide,	INPUT SELECT
S301,401	1-516-691-00	Lever-slide,	PB HEAD
S371	1-516-481-00	Lever-slide,	TAPE SELECT; BIAS
S372	1-516-482-00	Lever-slide,	TAPE SELECT; EQ
S591,691	1-516-685-00	Lever-slide,	MONITOR
S701 ~ 706	1-516-028-00	Micro,	REC/rewind/stop/fast forward/playback
S1001,1002	1-516-619-00	Lever-slide,	REEL SIZE/TAPE SPEED
S1201	1-516-693-00	Push,	POWER (USA/Canada Model)
	1-516-628-00	Push,	POWER (E Model)
	1-516-855-00	Push,	POWER (UK Model)
S1202,1203	1-514-730-00	Micro,	SHUT OFF
LAMPS			
PL001~003	1-518-094-XX	6 V	35 mA
PL701~705	1-518-053-XX	28 V	40 mA
HEADS			
EH001	8-828-522-00	Erase,	EF18-2202
RH002	8-825-558-10	Record,	RF142-2202B
PH003	8-825-638-00	Playback,	PF164-2202
PH004	8-825-636-10	Playback,	PF142-4202A
MISCELLANEOUS			
CP051	1-464-029-12	Bias Osc Unit,	160 kHz
CP901~904	1-101-534-31	Encapsulated Component,	C-R
CP1201	1-101-534-31	Encapsulated Component,	C-R (USA/Canada Model)
	1-231-057-31	Encapsulated Component,	C-R (E Model)
CP1201, CP1203	1-101-534-31	Encapsulated Component,	C-R
F1	1-532-235-00	Fuse,	315 mA (UK Model)
F2	1-532-350-00	Fuse,	4 AT (UK Model)
F3, 4, 5	1-532-279-00	Fuse,	500 mA (UK Model)
F6	1-532-078-00	Fuse,	1 AT (UK Model)
F7, 9	1-532-279-00	Fuse,	500 mA (UK Model)
F8	1-532-284-00	Fuse,	630 mA (UK Model)
F10	1-533-082-00	Fuse,	2 A (UK Model)

<u>Ref. No.</u>	<u>Part No.</u>	<u>Description</u>
F1201	1-532-100-00	Fuse, 2 A (E Model)
	1-532-298-00	Fuse, 2 A (USA/Canada Model)
F1202	1-532-268-00	Fuse, 2 A (USA Model Serial No. 10,051 and later) (Canada Model Serial No. 10,021 and later) (E Model Serial No. 10,011 and later)
M1301,1302	8-832-638-05	Motor, supply/take-up reel; IC-638R
M1303	8-836-124-10	Motor, capstan; uc-124G
ME	1-520-186-31	Meter, PEAK PROGRAM
PM1203	1-454-145-00	Solenoid, SHIFTER
PM1204 PM1205	1-454-143-00	Solenoid, BRAKE
RY701,702	1-515-256-00	Relay, 24 V
RY901	1-515-127-00	Relay, 24 V 37 mA
	1-452-072-00	Ring, magnet
	1-506-180-00	Plug, dummy
	1-507-255-00	Socket, REMOTE CONTROL
	1-509-427-00	Voltage Selector (E Model)
	1-509-482-00	Voltage Selector (UK Model)
	1-517-018-00	Holder, lamp
	1-533-048-XX	Holder, fuse (USA/Canada/E Model)
	1-533-082-00	Holder, fuse (UK Model)

<u>Ref. No.</u>	<u>Part No.</u>	<u>Description</u>
JACKS		
CNJ1	1-507-300-00	Connector, 22 p
CNJ2~4	1-509-583-00	Connector, 10 p
CNJ5	1-509-668-00	Connector, 18 p
CNJ7	1-509-584-00	Connector, 8 p
CNJ14, 15	1-509-303-00	Connector XLR-3-13; MIC IN (USA/Canada Model)
	1-509-304-00	Connector, ELR-3-14; MIC IN (E Model)
CNJ16, 17	1-507-378-XX	Jack, 2 p; LINE IN
CNJ18, 19	1-507-378-XX	Jack, 2 p; LINE OUT
CNJ20	1-509-062-00	Connector, AC IN (USA/Canada/E Model)
	1-509-547-00	Connector, AC IN (UK Model)
CNJ21	1-526-528-00	Connector, AC OUTLET (USA/Canada/E Model)
CNP2~4	1-508-699-00	Connector, 10 p
CNP6	1-508-693-00	Connector, 10 p
CNP7	1-508-694-00	Connector, 8 p
CNP8~10	1-508-693-00	Connector, 10 p
CNP11	1-508-694-00	Connector, 8 p
CNP12, 13	1-508-693-00	Connector, 10 p
CON	1-508-744-00	Connector, 10 p
J101, 201	1-507-476-XX	Jack, phone; MIC
J501	1-507-476-XX	Jack, binaural; HEADPHONES

ACCESSORIES

<u>Part No.</u>	<u>Description</u>	<u>Part No.</u>	<u>Description</u>
X-3141-019-0	Adaptor Ass'y	1-534-819-11	Cord, power (UK Model)
X-3701-018-0	Tips Ass'y, head cleaning (Canada Model)	3-780-811-21	Manual, instruction (USA Model)
1-534-049-51	Cord, connection; RK-74H	3-780-811-32	Manual, instruction (Canada/E/UK Model)
1-534-099-XX	Cord, power (E Model)	3-793-010-20	Booklet, tape talk
1-534-262-16	Cord, power (USA Model)	8-823-502-00	Tape, Fe-Cr (E/UK Model)
1-534-375-12	Cord, power (Canada Model)	8-860-018-00	Reel, metal: R-11A

TC-880-2

9-954-360-01

Sony Corporation

© 1975

610505-2
Printed in Japan