

TC-C5/C521

SERVICE MANUAL

US Model
TC-C5/C521

Canadian Model
AEP Model
UK Model
E Model
TC-C5



Discard TC-C5 Service Manual
(No. 9-956-655-11) previously issued.
This Service Manual contains it.

Photo : TC-C5

SPECIFICATIONS

Recording system 4-track 2-channel stereo
Fast-winding time Approx. 90 sec. (with Sony C-60 cassette)
Bias AC bias
Heads Erasing head × 1 (ferrite head)
Playback/Recording head × 1 (LA head)
Motors Capstan motor × 1 (DC servo motor)
Reel motor × 1 (DC motor)
ASIST (mechanical drive) motor × 3 (DC motor)

Signal-to-noise ratio (at peak level)

Cassette	Dolby NR switch		
	OFF	B-Type ON	C-Type ON
Type IV (Sony METAL-SLT)	59 dB	67 dB	74 dB
Type II (Sony UX-S)	58 dB	66 dB	73 dB
Type I (Sony HF-S)	56 dB	64 dB	71 dB

Total harmonic distortion 1% (with Sony METAL-SLT cassette)
Frequency response (DOLBY NR OFF)

Type IV cassette (Sony METAL-SLT)	20 - 19,000 Hz (±3 dB, IEC) 30 - 15,000 Hz (±3 dB 0VU (-4 dB) recording)
Type II cassette (Sony UX-S)	25 - 17,000 Hz (±3 dB, IEC)
Type I cassette (Sony HF-S)	25 - 16,000 Hz (±3 dB, IEC)

Wow and flutter ±0.09% W. Peak (IEC)
0.06% WRMS (NAB)
±0.16% W. Peak (DIN)

Model Name Using Similar Mechanism	TC-WR820
Tape Transport Mechanism Type	TCM-200R30

Line inputs (phono jacks)
Sensitivity 77.5 mV
Input impedance 47 k ohms

Outputs

Line outputs (phono jacks)	Rated output level	0.32 V at a load impedance of 47 k ohms
	Load impedance	Over 10 k ohms
Headphones (stereo phone jack)	Output level	0.3 mW at a load impedance of 32 ohms

General

Power requirements US, Canadian model : 120V AC, 60Hz
AEP, Germany model : 220-230V AC, 50/60Hz
UK model : 240V AC, 50/60Hz
E model : 120, 220, 240V AC, 50/60Hz

Power consumption 20 W
Dimensions Approx. 430 × 135 × 350 mm (w/h/d)

(17 × 5³/₈ × 13⁷/₈ inches) : TC-C5
Approx. 430 × 130 × 350 mm (w/h/d)
(17 × 5¹/₈ × 13⁷/₈ inches) : TC-C521
including projecting parts and controls
Weight Approx. 6.7 kg (14 lb 13 oz) : TC-C5
Approx. 6.9 kg (15 lb 3 oz) : TC-C521

Supplied accessories

Audio connecting cords (2)
Wireless remote commander RM-J801(1) : TC-C5
Sony size-AA (R6) batteries(2)

Design and specifications are subject to change without notice.

STEREO CASSETTE DECK
SONY®

* Dolby noise reduction and HX Pro headroom extension manufactured under license from Dolby Laboratories Licensing Corporation. HX Pro originated by Bang & Olufsen.

"DOLBY", the double-D symbol  and "HX PRO" are trademarks of Dolby Laboratories Licensing Corporation.



Refer to the additional documents

SAFETY CHECK-OUT

After correcting the original service problem, perform the following safety check before releasing the set to the customer:

Check the antenna terminals, metal trim, "metallized" knobs, screws, and all other exposed metal parts for AC leakage. Check leakage as described below.

LEAKAGE TEST

The AC leakage from any exposed metal part to earth ground and from all exposed metal parts to any exposed metal part having a return to chassis, must not exceed 0.5 mA (500 microampers). Leakage current can be measured by any one of three methods.

1. A commercial leakage tester, such as the Simpson 229 or RCA WT-540A. Follow the manufacturers' instructions to use these instruments.
2. A battery-operated AC milliammeter. The Data Precision 245 digital multimeter is suitable for this job.
3. Measuring the voltage drop across a resistor by means of a VOM or battery-operated AC voltmeter. The "limit" indication is 0.75 V, so analog meters must have an accurate low-voltage scale. The Simpson 250 and Sanwa SH-63Trd are examples of a passive VOM that is suitable. Nearly all battery operated digital multimeters that have a 2 V AC range are suitable. (See Fig. A)

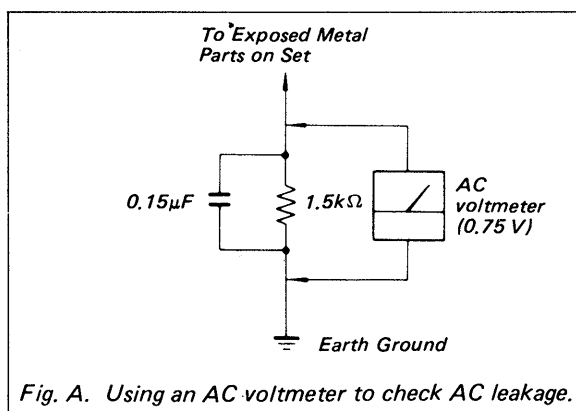



Fig. A. Using an AC voltmeter to check AC leakage.

SAFETY-RELATED COMPONENT WARNING!!

COMPONENTS IDENTIFIED BY MARK  OR DOTTED LINE WITH MARK  ON THE SCHEMATIC DIAGRAMS AND IN THE PARTS LIST ARE CRITICAL TO SAFE OPERATION. REPLACE THESE COMPONENTS WITH SONY PARTS WHOSE PART NUMBERS APPEAR AS SHOWN IN THIS MANUAL OR IN SUPPLEMENTS PUBLISHED BY SONY.

Section	Title	Page
SERVICE NOTE	3
SECTION 1. GENERAL	5
SECTION 2. DISASSEMBLY	6
SECTION 3. DIAGRAM	10
SECTION 4. MECHANISM OPERATION	13
SECTION 5. ADJUSTMENTS	17
SECTION 6. DIAGRAMS		
6-1. Printed Wiring Boards		
— Audio/System Control Section Former Type —	21
6-2. Printed Wiring Boards		
— Audio/System Control Section New Type —	25
6-3. Schematic Diagram — System Control Section —	29
IC Block Diagram	32
6-4. Circuit Boards Location	33
6-5. Schematic Diagram — Audio Section —	33
6-6. Printed Wiring Board — TC Section —	37
Fluorescent Indicator Tube	39
Semiconductor Lead Layouts	40
SECTION 7. EXPLODED VIEWS		
7-1. Drum Section	41
7-2. Front Panel Section	42
7-3. Slider Section	43
7-4. Chassis Section	44
7-5. Mechanism Section 1	45
7-6. Mechanism Section 2	46
SECTION 8. ELECTRICAL PARTS LIST	47

MODEL IDENTIFICATION

— Specification Label —

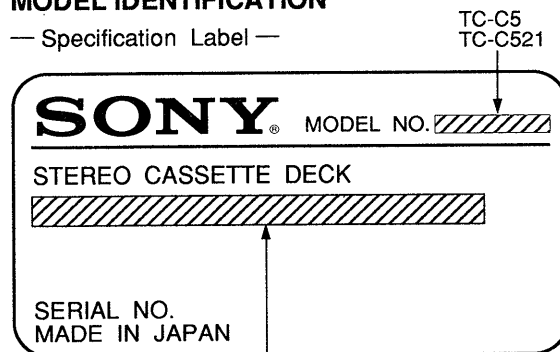

- US, Canadian model: AC120V 60Hz 20W
- AEP, Germany model: AC220-230V~50/60Hz
- UK model: AC240V~50/60Hz
- E model: AC120, 220, 240V~50/60Hz 20W

ATTENTION AU COMPOSANT AYANT RAPPORT À LA SÉCURITÉ!

LES COMPOSANTS IDENTIFIÉS PAR UNE MARQUE  SUR LES DIAGRAMMES SCHÉMATIQUES ET LA LISTE DES PIÈCES SONT CRITIQUES POUR LA SÉCURITÉ DE FONCTIONNEMENT. NE REMPLACER CES COMPOSANTS QUE PAR DES PIÈCES SONY DONT LES NUMÉROS SONT DONNÉS DANS CE MANUEL OU DANS LES SUPPLÉMENTS PUBLIÉS PAR SONY.

SERVICE NOTE

Notes on Repair

Be sure to follow these instructions if the tape is jammed in the mechanism.

NOTE : Follow the disassembly procedure in the numerical order given.

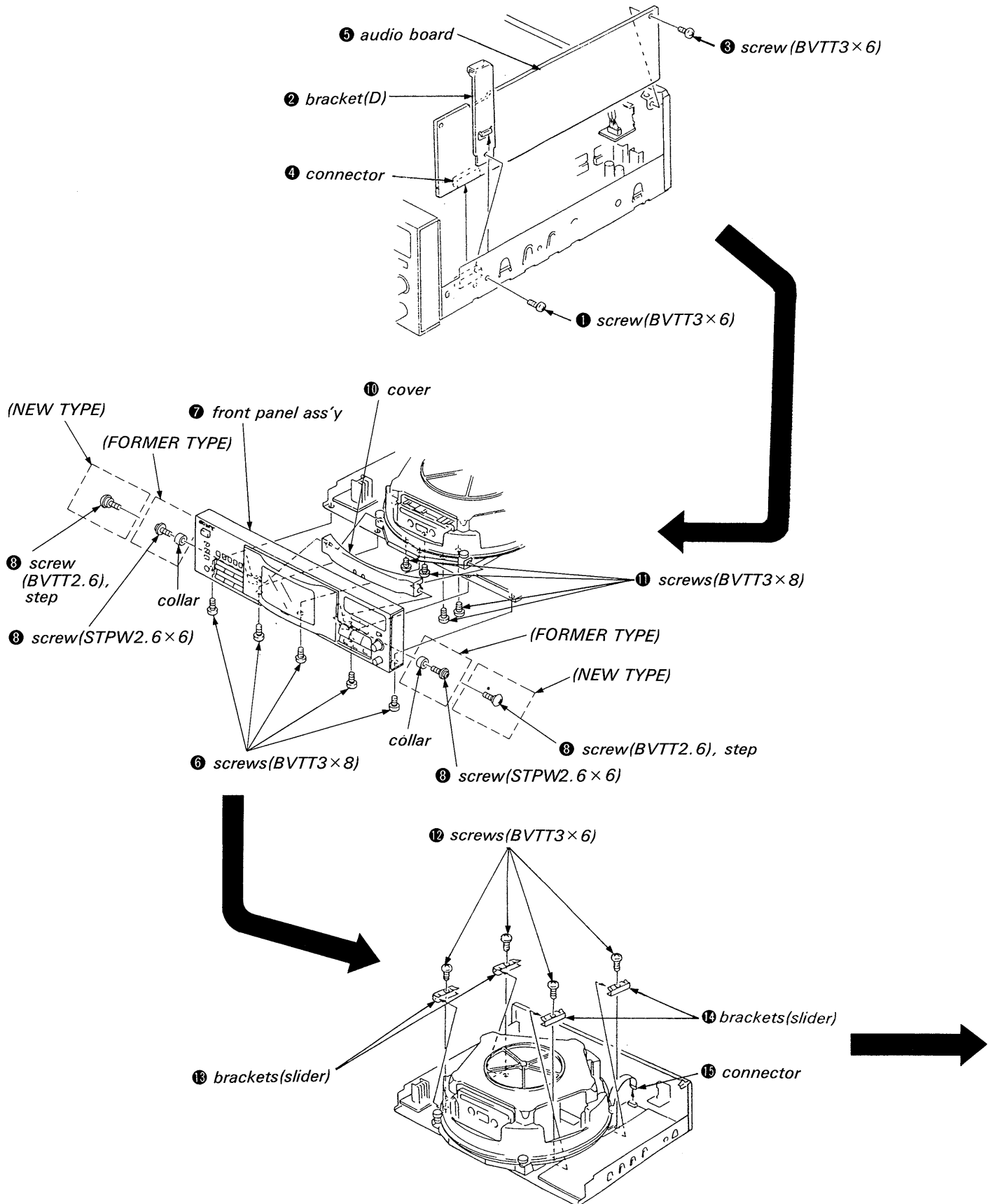

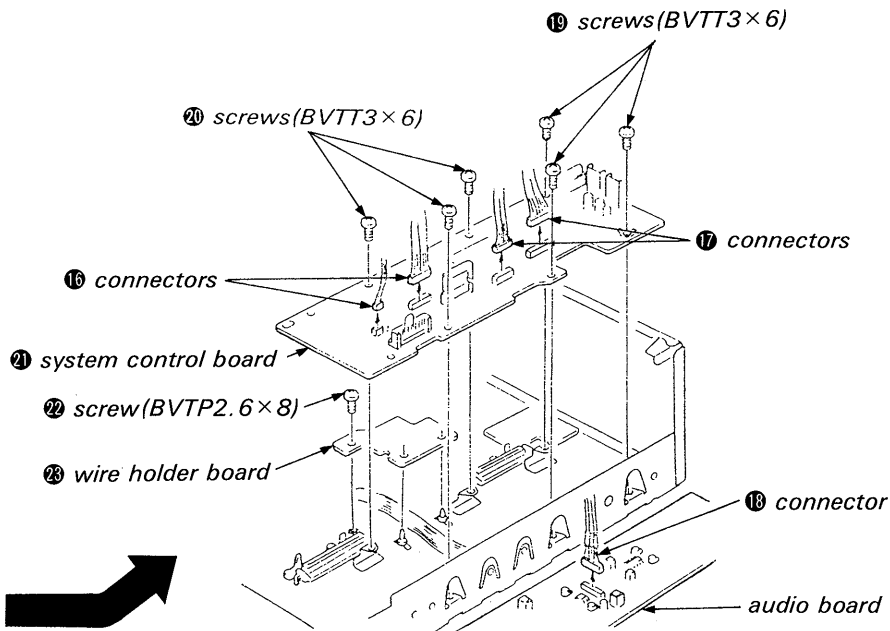
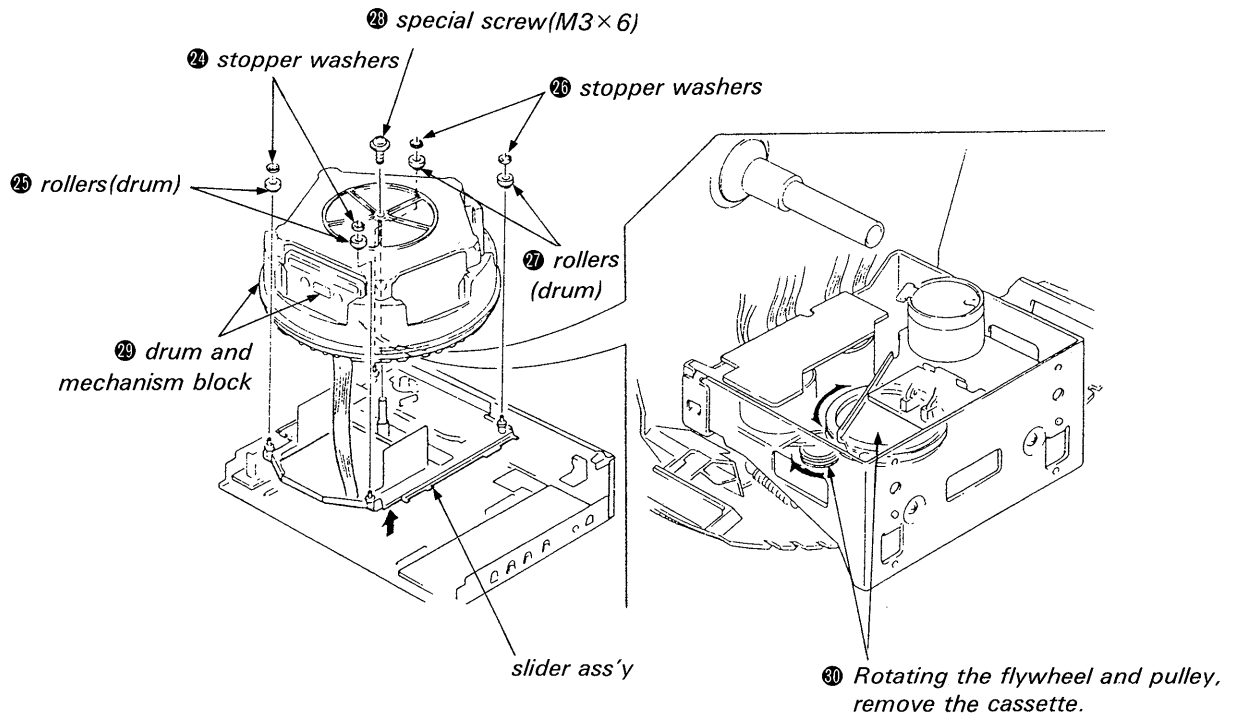

SECTION 1 GENERAL

This section is extracted from instruction manual.



Identifying the Parts

Front Panel

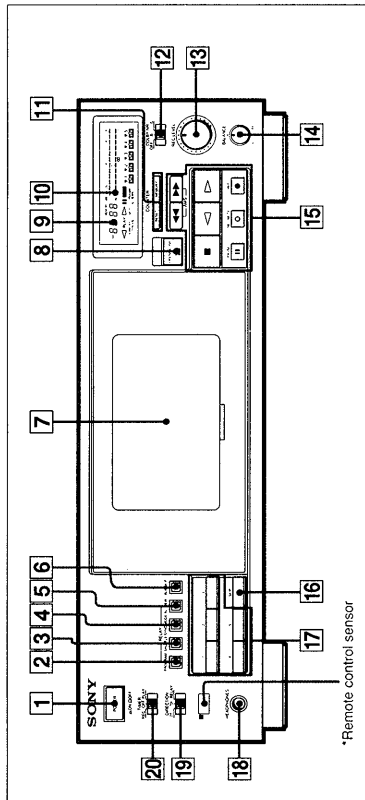

*Remote control sensor

For details, refer to the page number indicated in ●

- 1 POWER switch
- 2 PROGRAM button ①
- 3 SHUFFLE button ①
- 4 SYNC MODE button ①
- 5 ALL REW (rewind) button ①
- 6 BLK (blank) SKIP button ①
- 7 Cassette holders
- 8 OPEN/CLOSE button
- 9 LINEAR COUNTER ①
- 10 PEAK LEVEL METER ①
- 11 COUNTER buttons
RESET button ①
MEMORY button ①
- 12 DOLBY NR (noise reduction) switch ① ② ③ ④
- 13 REC (recording) LEVEL control ① ②
- 14 BALANCE control ① ②
- 15 Tape operation buttons
◀ (leftward fast winding) button
▶ (rightward fast winding) button
■ (stop) button
◁ (reverse play) button
▷ (forward play) button
⏏ PAUSE button
● REC MUTE (record muting) button ②
● REC (record) button
- 16 SKIP button ① ② ③
- 17 Cassette buttons ① ② ③
- 18 HEADPHONES jack (stereo phone jack)
- 19 DIRECTION mode switch ① ②
- 20 TIMER switch ②

*Remote control sensor
You can remotely control this cassette deck with:
— A remote commander that came with a Sony amplifier or receiver if it has the mark and cassette deck control capability.
— An optional Sony remote commander with the mark and cassette deck control capability.

Remote Commander

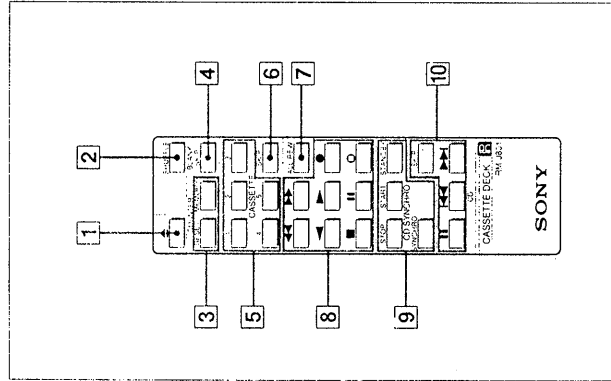

The controls on the remote commander are identical in function and operation to those with the same name on the main unit.

For details, refer to the page number indicated in ●

- 1 OPEN/CLOSE button
- 2 SHUFFLE button ①
- 3 COUNTER buttons ①
- 4 BLANK SKIP button ①
- 5 CASSETTE buttons ① ② ③ ④
- 6 SKIP button ① ② ③
- 7 ALL REW (rewind) button ①
- 8 Tape operation buttons
- 9 CD SYNCHRO buttons ① for synchronized recording with a Sony CD player
- 10 CD (Compact Disc) buttons
SKIP button
⏏ (pause) button
◀ / ▶ buttons for locating selections sequentially

Installing Batteries into the Remote Commander

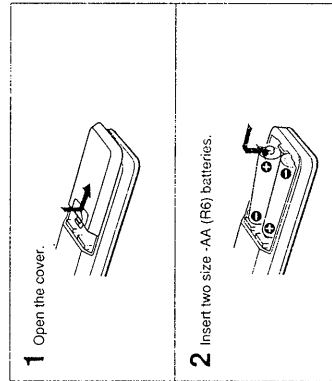

On battery life

- About half a year of normal operation can be expected when using the Sony SUM-3(NS) batteries.
- When the batteries are run down, the remote commander will not operate the unit. In this case, replace both batteries with new ones.

On handling

- Keep the commander away from extremely hot or humid places.
- Avoid dropping any foreign objects into the commander casing, particularly when replacing the batteries.
- Avoid exposing the remote sensor to direct sunlight or lighting apparatus. Such exposure can cause a malfunction.
- To avoid damage caused by battery leakage and corrosion, remove the batteries when the commander will not be used for a long time.

SECTION 2 DISASSEMBLY

NOTE : Follow the disassembly procedure in the numerical order given.

DRUM

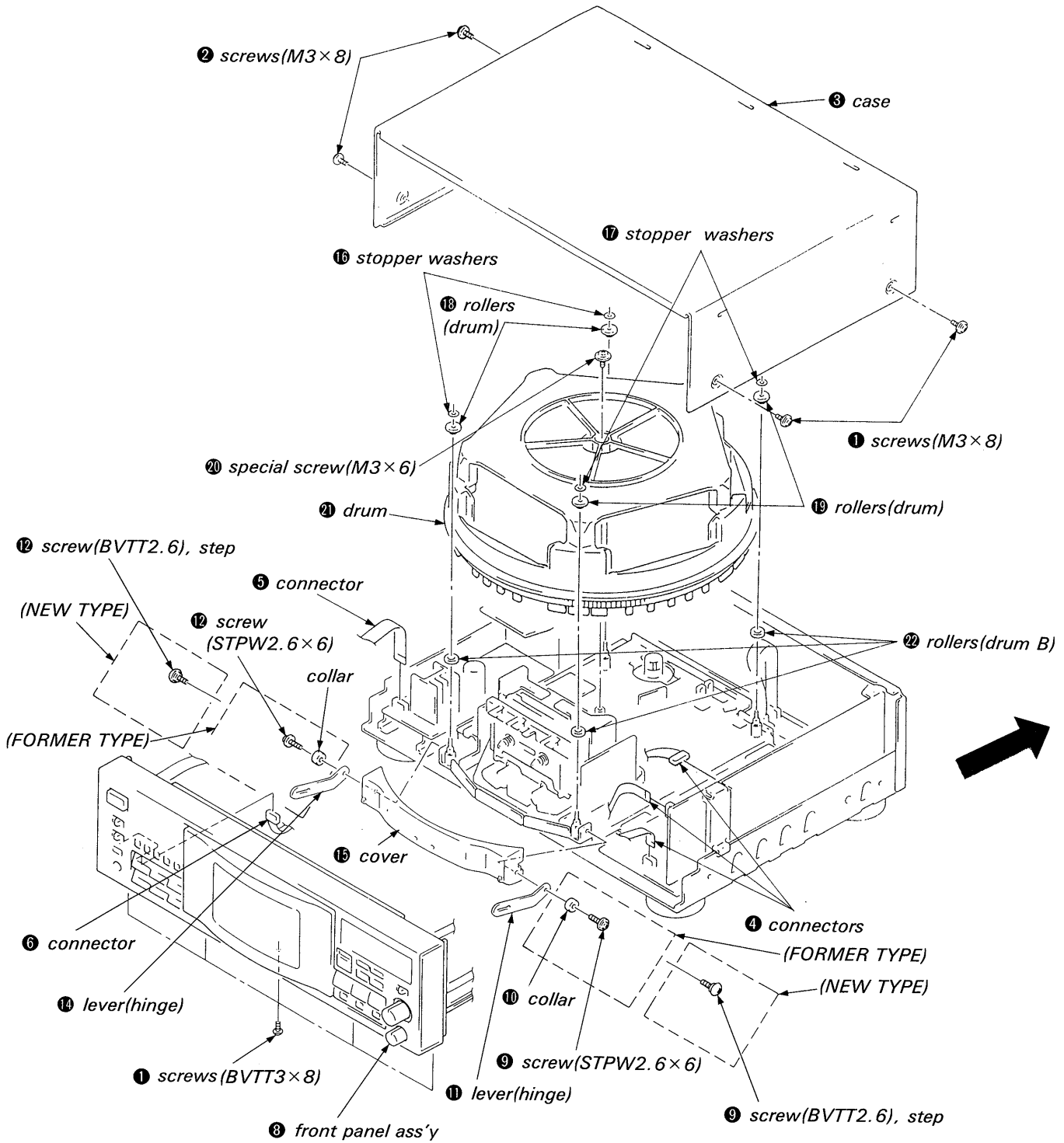

MECHANISM BLOCK

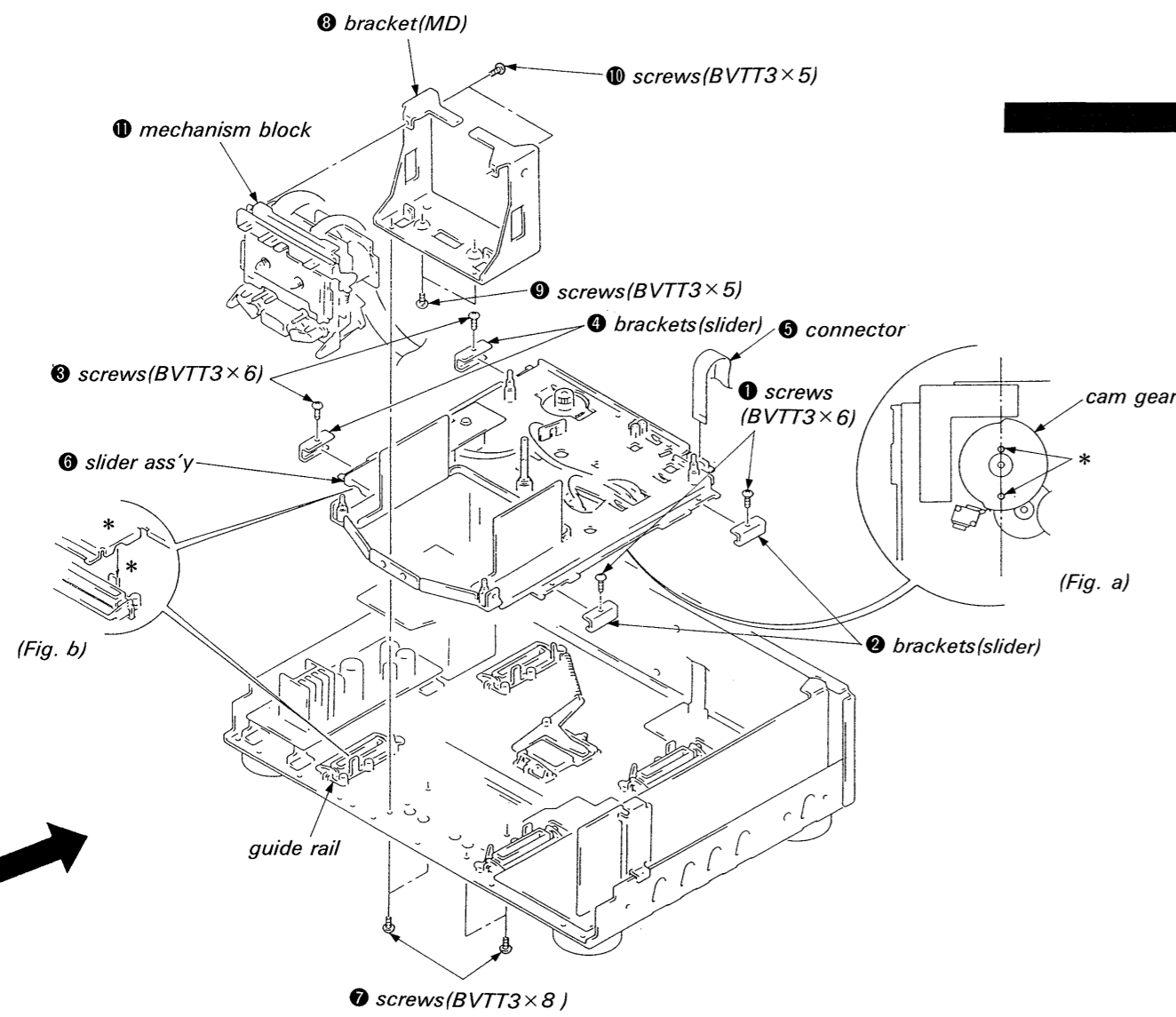

(Installation)

1. Rotate the cam gear so that two bosses marked with * are aligned as shown in Fig. a.
2. Insert the shaft into guide rail while aligning a notched face marked with * with the end face marked with * of guide rail as shown in Fig. b.

ORNAMENTAL PLATE

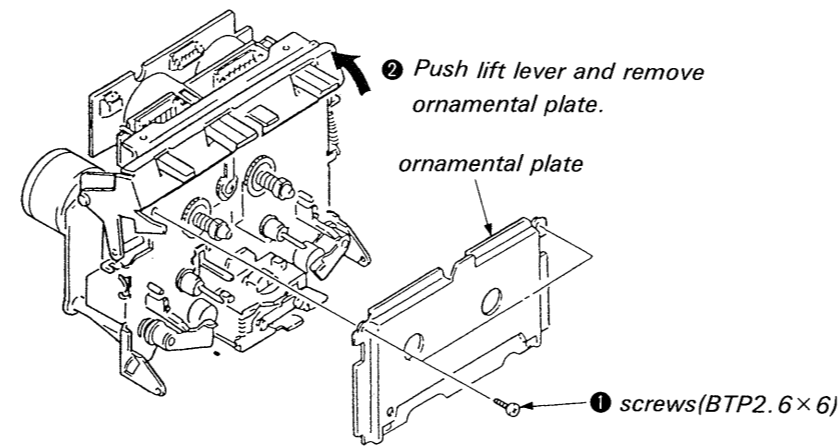

CAPSTAN MOTOR/FLYWHEEL

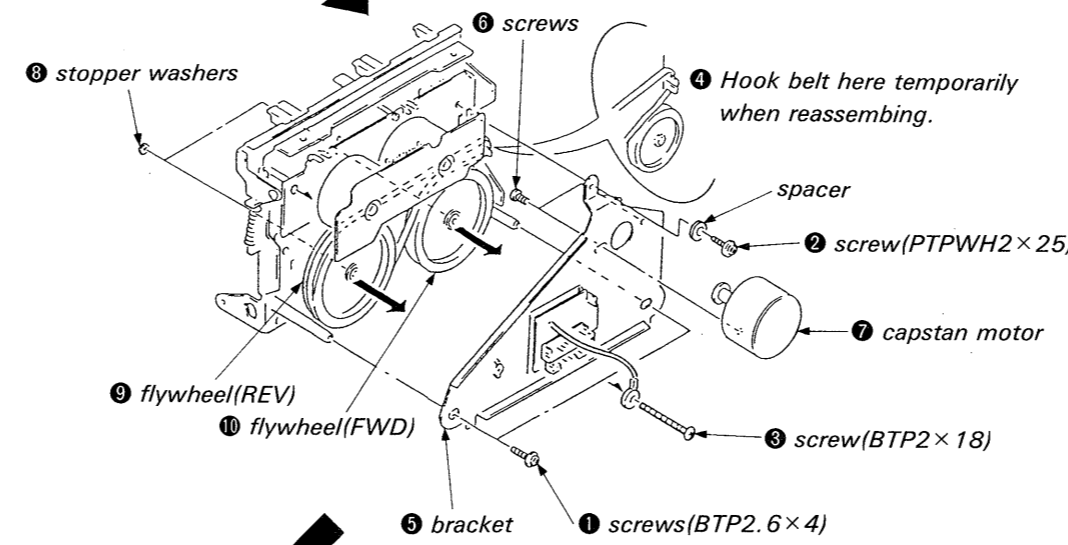

PINCH LEVER/HEAD

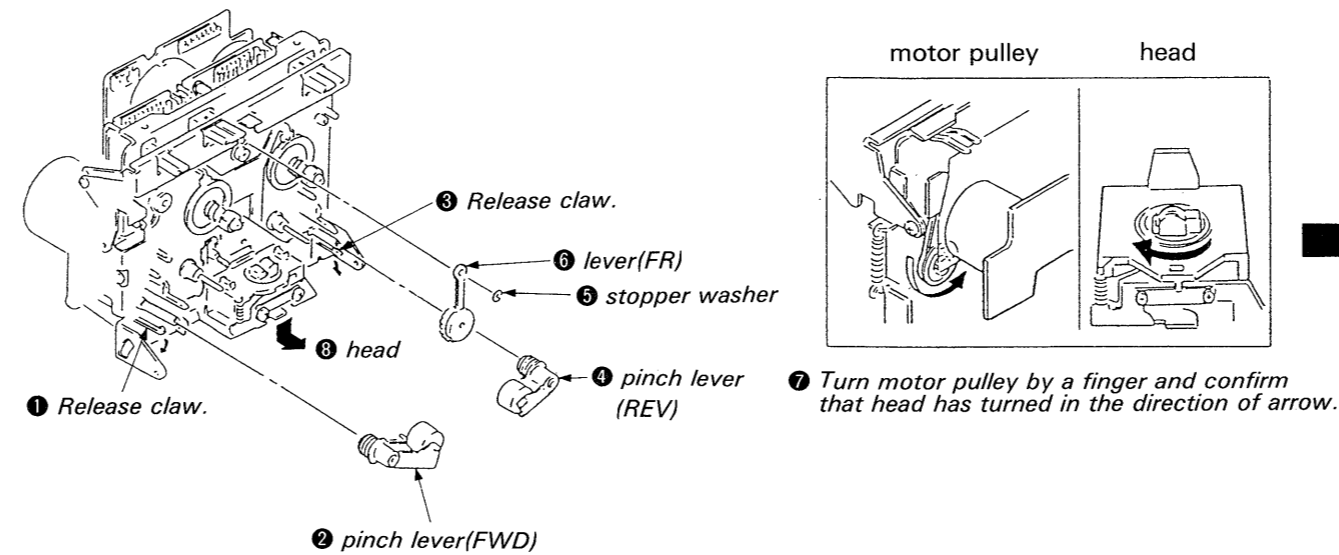

REEL AND ASSIST MOTORS

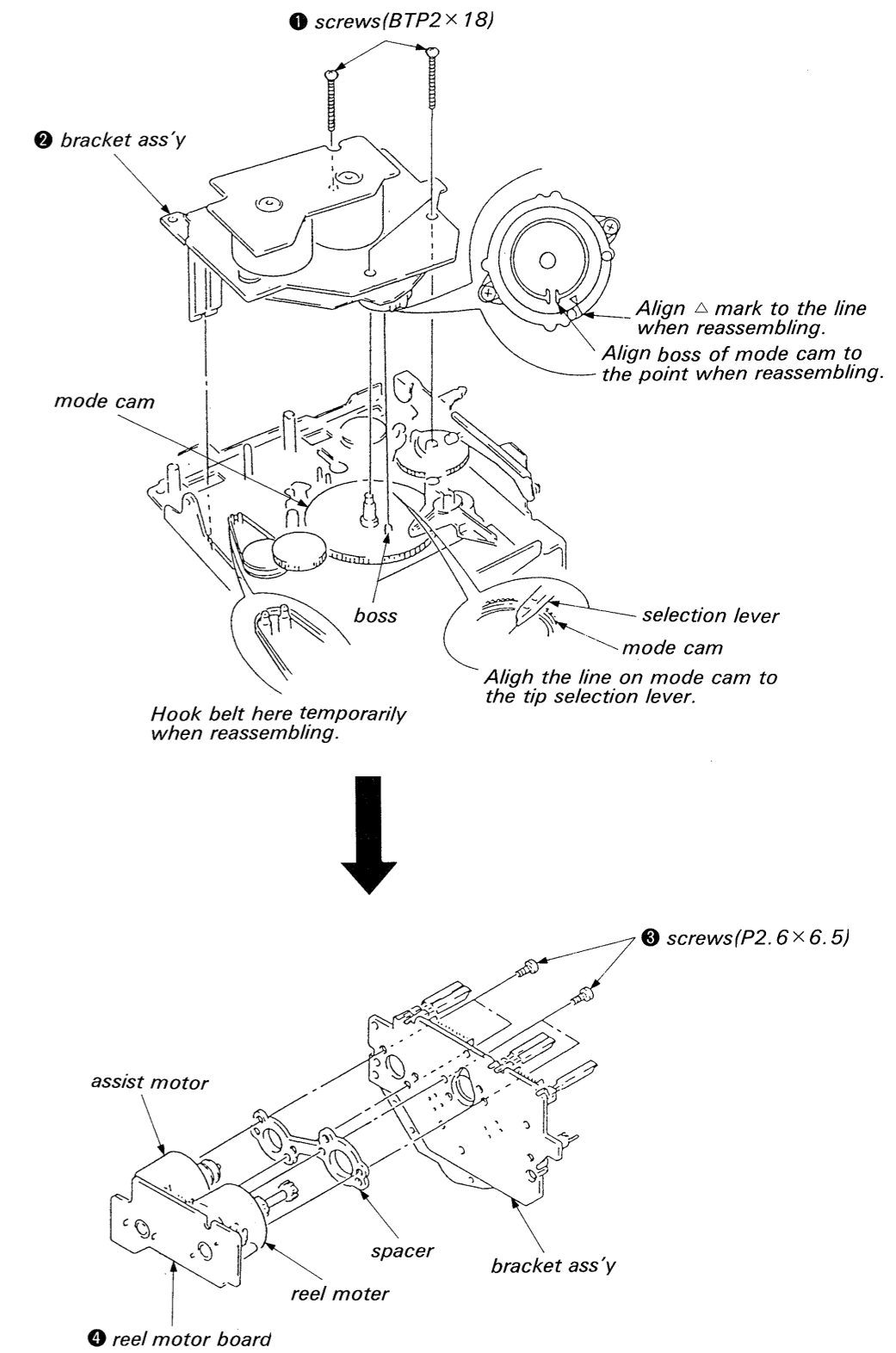

SECTION 3
DIAGRAM

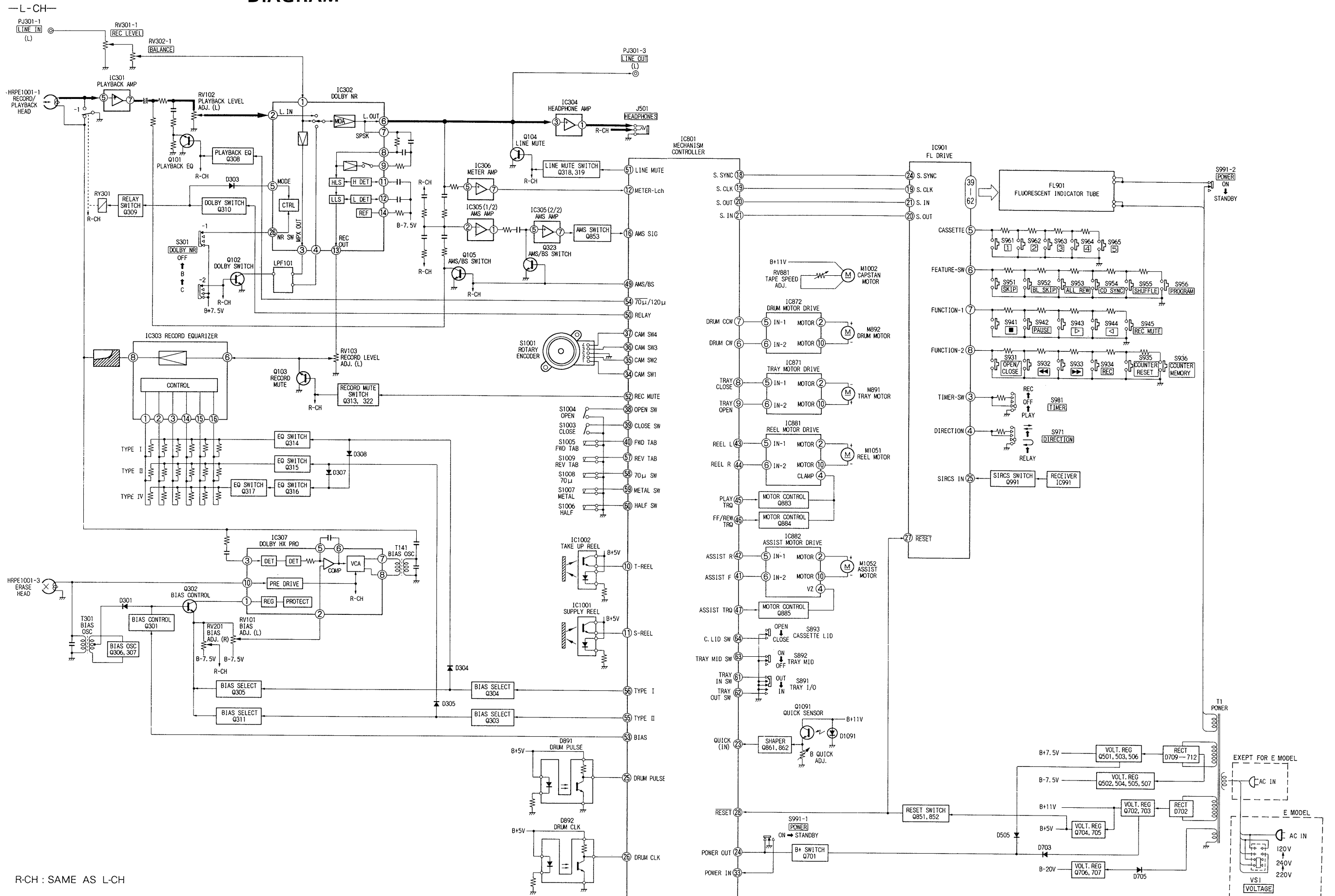

R-CH : SAME AS L-CH

SECTION 4 MECHANISM OPERATION

1. IN THIS UNIT, TWO MOTORS FOR DRUM AND TRAY ROTATE THE DRUM AND OPEN/CLOSE THE TRAY.

Before explanation of each operation, main mechanical part names and electrical part names are described.

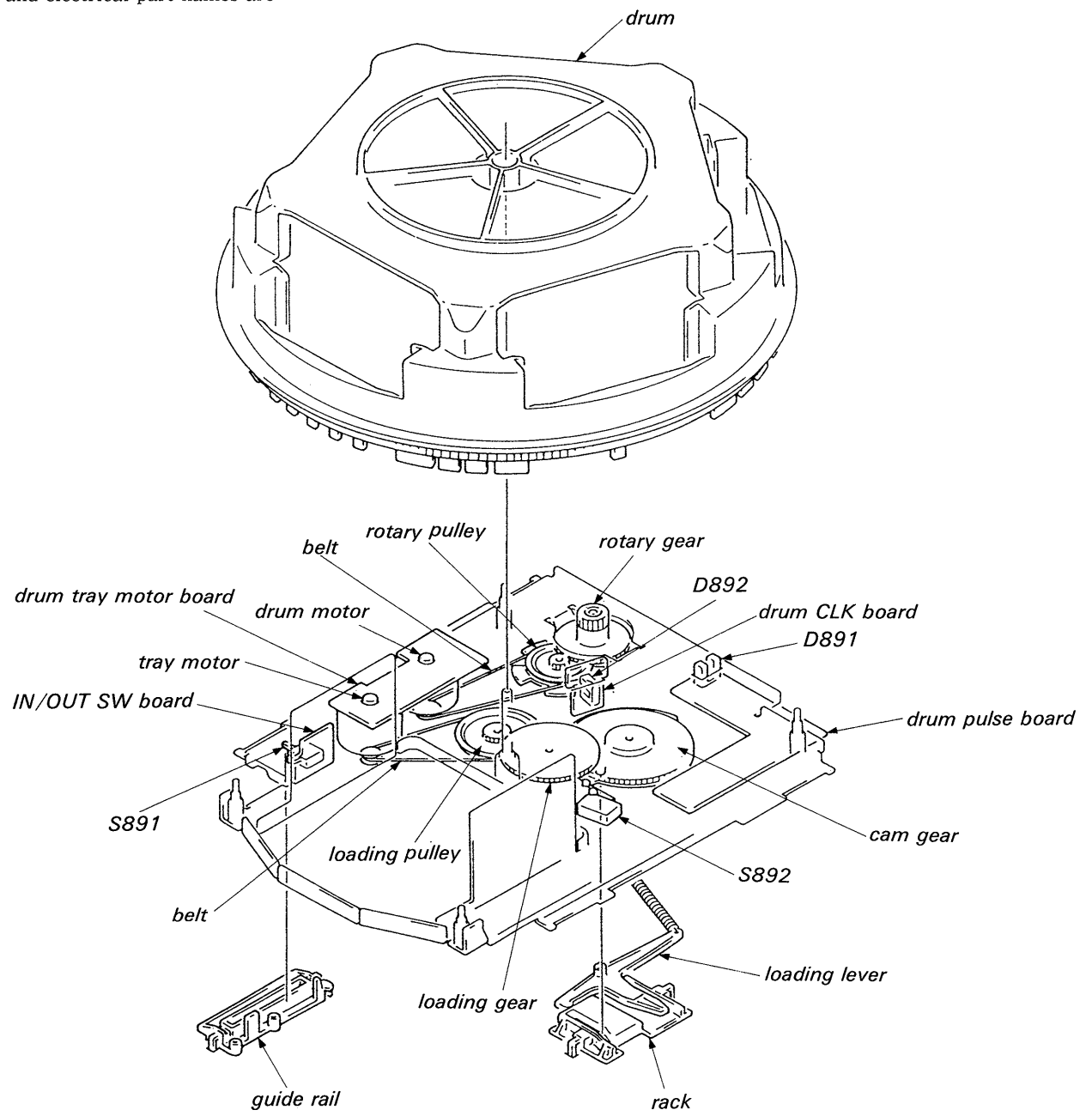

Fig. 1

2. DRUM ROTATION

Drum is driven by the drum motor. As shown in Fig. 2, the drum motor rotates the pulley and rotary gear via belt to rotate the drum.

DETECTION OF CASSETTE HOLDER POSITION

The D891 on the drum pulse board detects the cassette holder position by detecting a slit in the bottom of drum. Holder rotation stop position is detected at the position shown with arrow in Fig. 3, and holder number is detected at A position.

The D892 on the drum CLK board detects the drum motor rotation pulses to control the slit detection by D891. Thus, the motor control is executed by double detections.

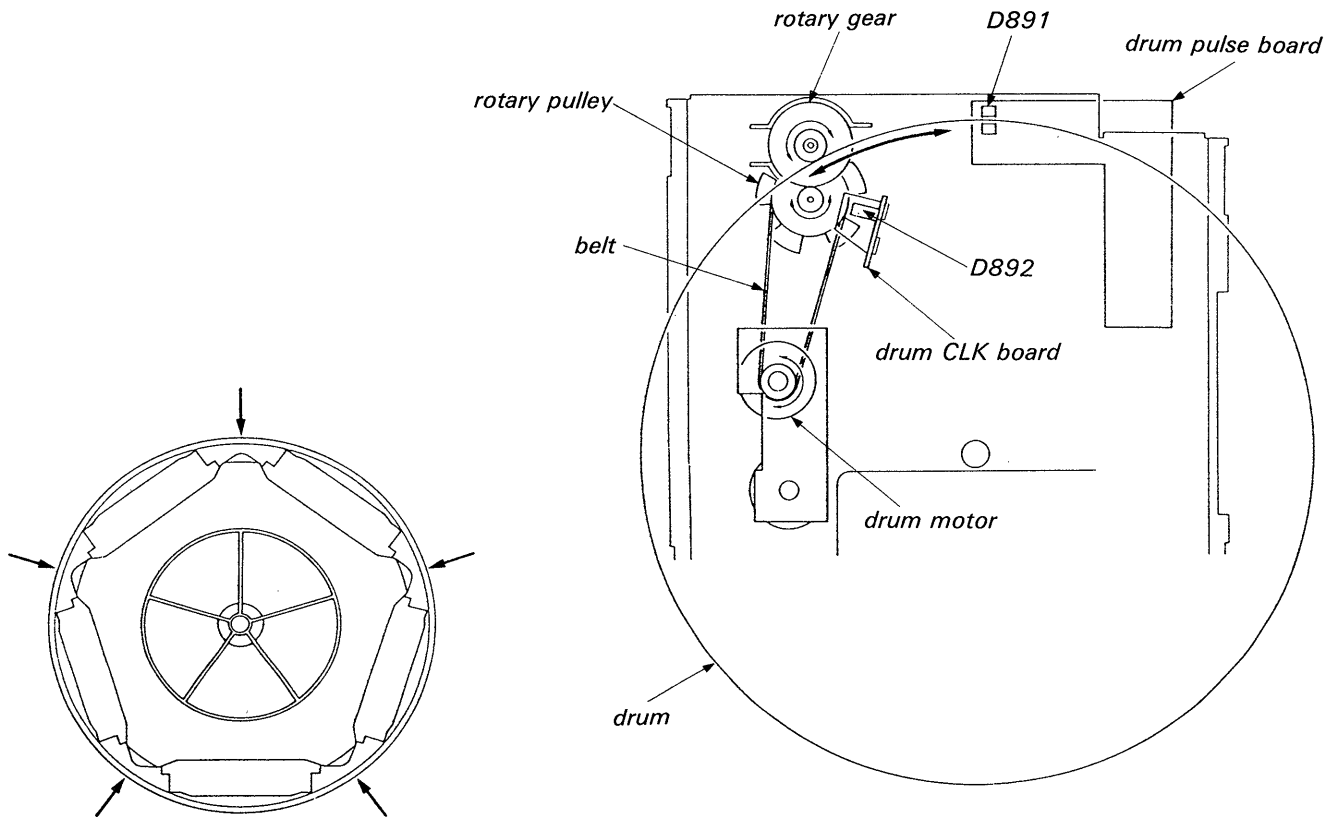

Fig. 2

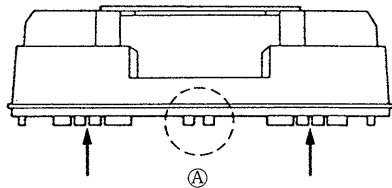
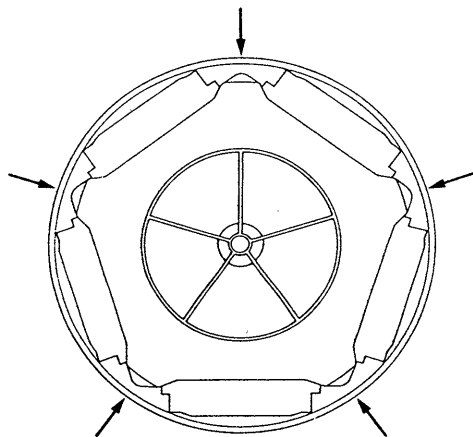

Fig. 3

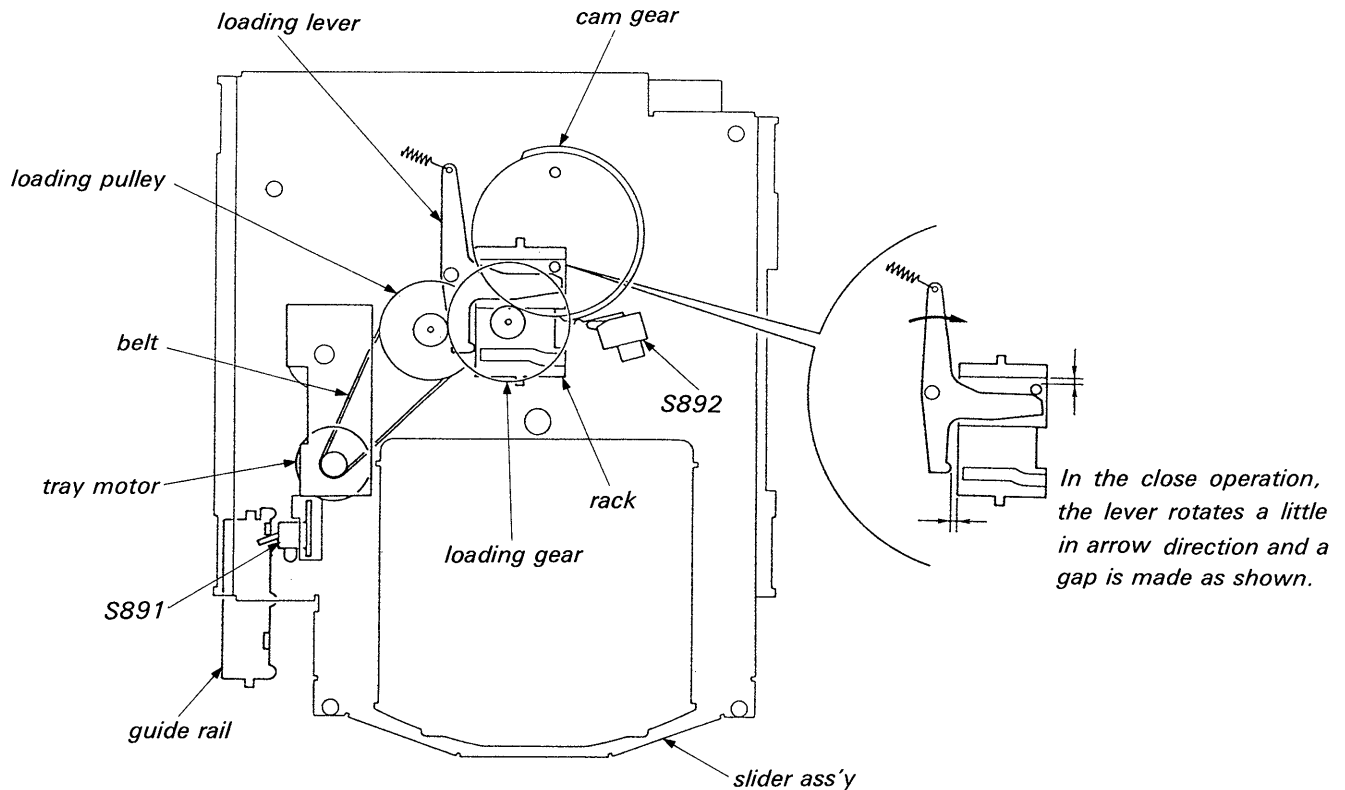

Fig. 4

3. OPEN/CLOSE OPERATION

Fig. 4 shows a close state. Operation from this state to the point where the drum can start to rotate is described below. (Fig. 5)

- (1) The tray motor rotates in arrow direction and the loading pulley rotates in arrow direction via belt.
- (2) Rotation of loading pulley drives the cam gear in arrow direction via loading gear.
- (3) Two bosses of cam gear and rack transform cam gear rotation into linear motion of Slider ass'y.
- (4) S892 detects completion of slider ass'y.

The close operation is performed reversely to the above operation and S891 detects completion of close operation. (Fig. 4)

4. OPEN

- (1) Motor, pulley and gear perform the same operation as that up to the position where the drum can start to rotate.
- (2) S891 detects completion of operation by means of guide rail. (Fig. 6)

The close operation is performed reversely to the above operation and S891 detects completion of close operation. (Fig. 4)

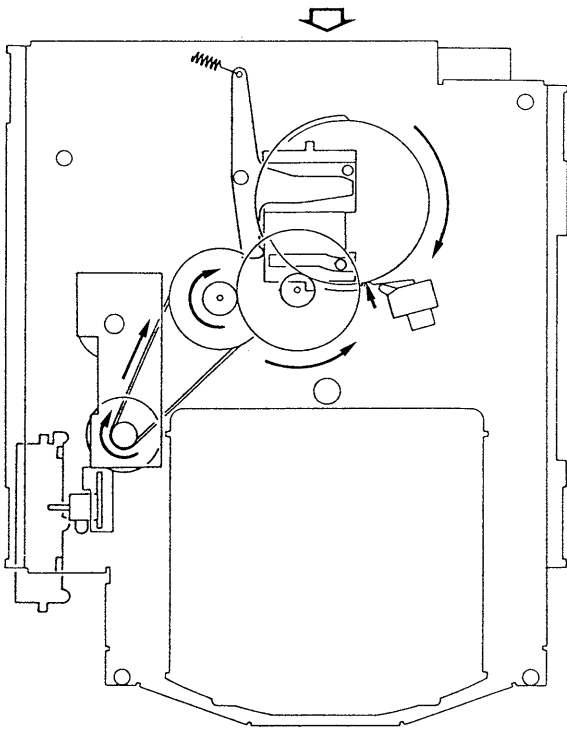

Fig. 5

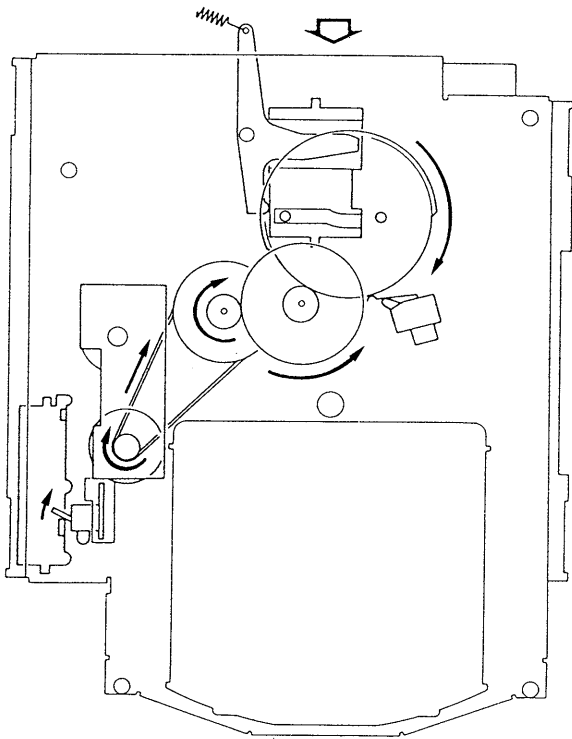

Fig. 6

SECTION 5 ADJUSTMENTS

5-1. MECHANICAL ADJUSTMENTS

PRECAUTION

1. Clean the following parts with a denatured-alcohol-moistened swab :
 - record/playback/erase head
 - pinch roller
 - rubber belts
 - capstan
 - idler
2. Demagnetize the record/playback head with a head demagnetizer.
3. Do not use a magnetized screwdriver for the adjustments.
4. After the adjustments, apply suitable locking compound to the parts adjusted.
5. The adjustments should be performed in the rated power supply voltage unless otherwise noted.

Torque Measurement

Torque	Torque meter	Meter reading
FWD	CQ-102C	30 - 60g · cm (0.42 - 0.83oz · inch)
FWD Back tention	CQ-102C	1 - 5g · cm (0.014 - 0.063oz · inch)
REV	CQ-102RC	30 - 60g · cm (0.42 - 0.83oz · inch)
REV Back tention	CQ-102RC	1 - 5g · cm (0.014 - 0.063oz · inch)
FF, REW	CQ-201B	65 - 100g · cm (0.9 - 1.39oz · inch)

5-2. ELECTRICAL ADJUSTMENTS

Note : The adjustment should be performed in the order given in the service manual. As a rule, adjustments about playback should be performed before those about recording. The adjustments should be performed for both L-CH and R-CH.

- Switches and controls should be set as follows unless otherwise specified.

DOLBY NR switch : OFF
 DIRECTION switch : \rightleftarrows
 TIMER switch : OFF

- Standard Record :

Deliver the standard input signal level to the input jack and set the REC LEVEL control to obtain the standard output signal level.

—Record Mode—

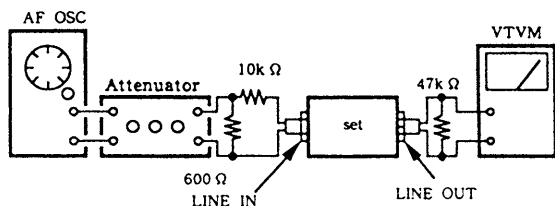

Standard Input Level

input terminal	LINE IN
source impedance	10k Ω
input level	0.25V (-10dB)

Standard Output Level

output terminal	LINE OUT
load impedance	47k Ω
output level	0.44V (-5dB)

Test tape

Type	Signal	Used for
P-4 · A100	10kHz, -10dB	Azimuth Adjustment
P-4 · L300	315Hz, 0dB	PB Level Adjustment
WS-48B	3kHz, 0dB	Tape Speed Adjustment
CS-123	————	Record Bias, Record Level and Quick Reverse Sensitivity Adjustment
CS-413	————	Bias Consumption Current Adjustment

0dB = 0.775V

- The set will get into TEST MODE by shorting the pins of TP801 (TEST) pins 2 and 3 on SYSTEM CONTROL board before turning the power on, and TEST MODE functions as follows :
- Remove a short pin after electrical adjustment is finished.

1. Source monitor

Cancels muting of line signal while recording.

2. Record memory stop

When starting recording, tape counter is reset to zero and counter memory turned on.

Record/Playback/Erase Head Azimuth Adjustment

Procedure :

1. Mode : FWD playback

Test tape
P-4-A100
(10kHz, -10dB)

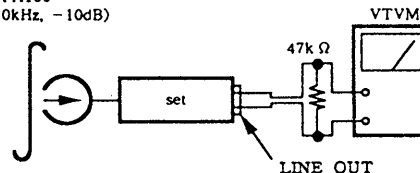

- Turn the adjustment screw for the maximum output levels. If these levels do not match, turn the adjustment screw until both of output levels match together within 1dB.

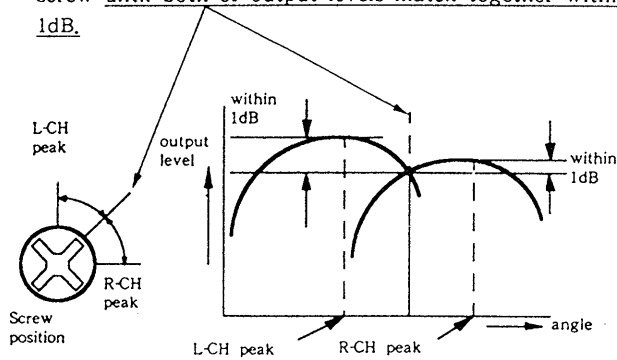

- Phase Check
Mode : playback

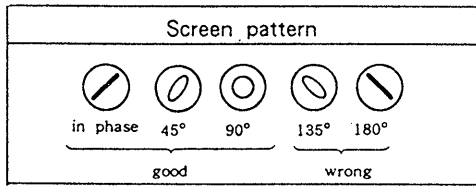
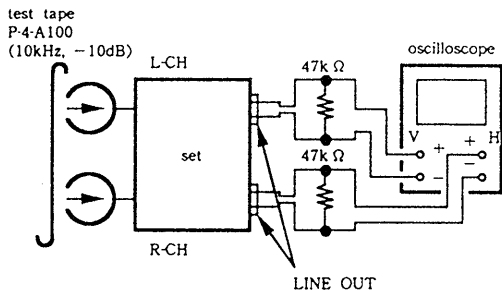

- Set in the REV mode and repeat the step 1-3.
- After the adjustment, lock the screws with locking compound.

Adjustment Location : Record / Playback / Erase head

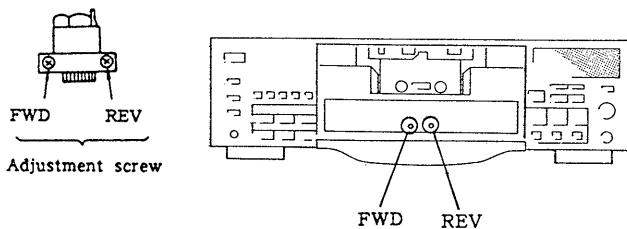

Tape Speed Adjustment

- Procedure :
Mode : playback

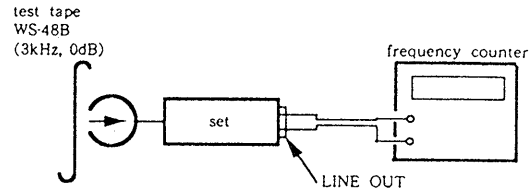

- Set to FWD playback mode.
- Adjust RV881 on SYSTEM CONTROL board so that the frequency counter reading becomes $3,000 \pm 15\text{Hz}$.

Frequency difference between the beginning and the end of the tape should be within 3%.

Adjustment Location : SYSTEM CONTROL board (See page 20.)

Playback Level Adjustment

- Procedure :
Mode : playback

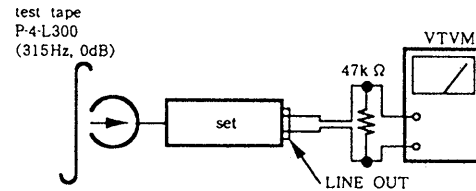

Adjust RV102 (L-ch) and RV202 (R-ch) for so that the reading on VTVM meets the adjustment limits below.

Adjustment Value : $-7.7\text{dB} \pm 0.5\text{dB}$ (0.3 to 0.34V)

Level difference between channels : less than 0.5dB
Check that the LINE OUT level does not change even if Playback and Stop operation is repeated several times.

Adjustment Location : AUDIO board (See page 20.)

Bias Consumption Current Adjustment

Procedure:

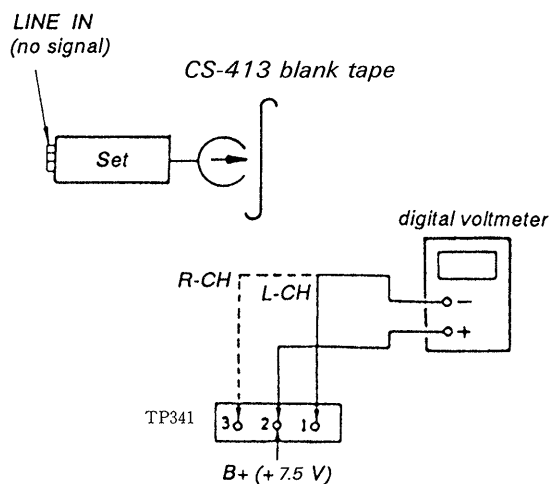

1. Set RV101 and RV201 to mechanical center and turn the set recording mode.
2. Connect digital voltmeter as shown by the following table.
3. Adjust the following transformers for the minimum readings on the digital voltmeter.

	Mesurement Point	Adjustment Part	Value
L-ch	② and ①, TP341	T141	not more than 130mV
R-ch	② and ③ TP341	T241	

Adjustment Location : AUDIO board (See page 20.)

Record Bias Adjustment

Setting :

REC LEVEL control : standard Record (See page 17.)
 TP801(TEST)pins 2 and 3 : short

Procedure :

1. Mode : record

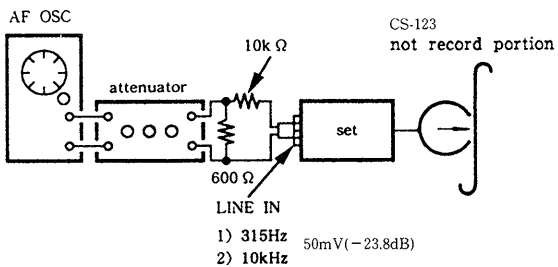

2. Mode : playback

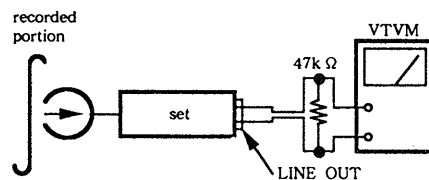

Playback the signal recorded in step 1.
 Confirm that the 10kHz playback output is $0 \pm 0.5\text{dB}$ relative to the 315Hz output. If necessary, adjust RV101 (L-ch) and RV201 (R-ch) for repeat the steps given above.

Adjustment Location : AUDIO board (See page 20.)

Record Level Adjustment

Setting :

REC LEVEL control : Standard Record (See page 17.)
 TP801(TEST)pins 2 and 3 : short

Procedure :

1. Mode : record

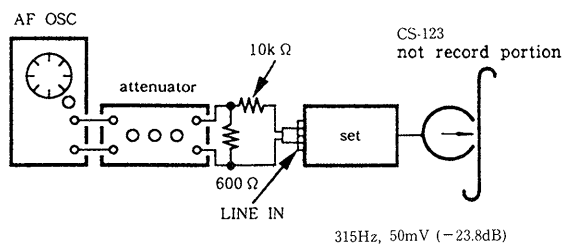

2. Mode : playback

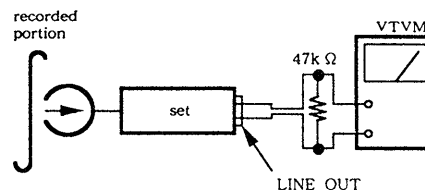

3. Playback the signal recorded in step1.
 Confirm that the signal level is within the adjustment limits below.
 If necessary, adjust RV103 (L-ch) and RV203 (R-ch) repeat the step1-2.

Adjustment Value : $-23.8\text{dB} \pm 0.5\text{dB}$ (53 to 47.2mV)

Adjustment Location : AUDIO board (See page 20.)

Quick Reverse Sensitivity Adjustment

Conditions :

DIRECTION MODE switch : \rightleftarrows

Adjustment procedure :

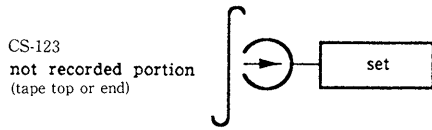

1. Connect the digital voltmeter to test point TP861.
2. Load CS-123 tape cassette and playback the leading portion in FWD mode.
3. Adjust the RV861 for $4.5 \pm 0.5V$ reading on the digital voltmeter.
4. Playback CS-123 tape cassette in FWD mode again.
5. Confirm that the reading on the digital voltmeter is "L" level at the magnetic portion of the tape.
6. Confirm that the tape stop around the tape end (border of the leading and the magnetic portions).

Adjustment Location : SYSTEM CONTROL board

Adjustment Parts Location Diagram

—SYSTEM CONTROL board—

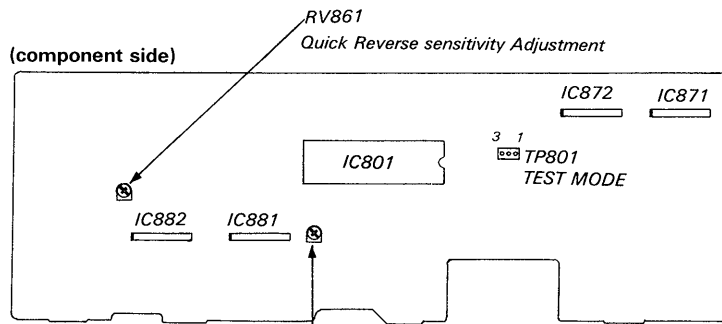

—AUDIO board—

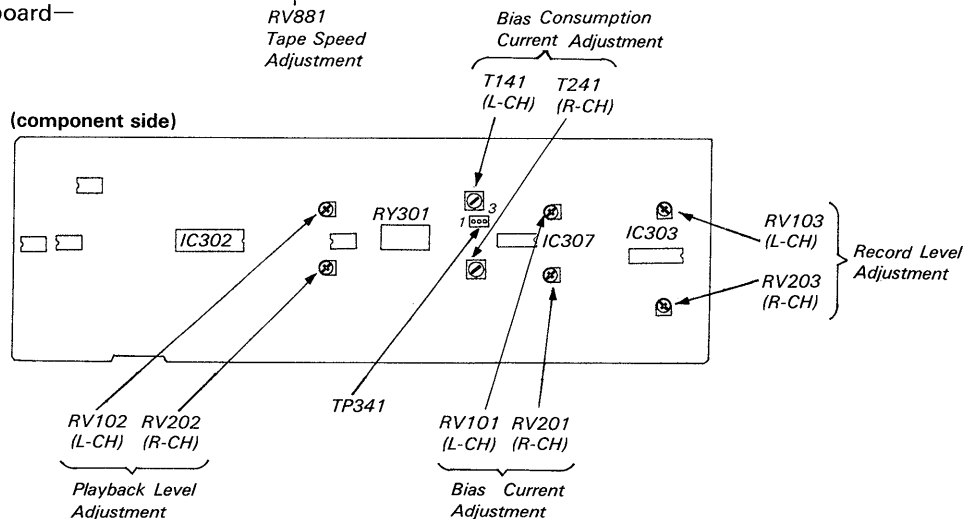

**SECTION 6
DIAGRAMS**

**6-1. PRINTED WIRING BOARDS—AUDIO/SYSTEM CONTROL Section FORMER TYPE—
(TC-C5 US, Canadian, AEP, Germany, UK model)**

• See page 33, 40 for Circuit Boards Location and Semiconductor Lead Layouts.

Note:
 ○ — : parts extracted from the component side.
 □ — : Pattern on the side which is seen.
 ● CND: Canadian
 ● G: Germany

● Semiconductor Location

Ref. No.	Location	Ref. No.	Location
D101	H-28	Q101	G-24
D201	I-28	Q102	H-24
D301	I-19	Q103	H-18
D302	H-22	Q104	H-27
D303	G-25	Q105	J-28
D304	G-19	Q201	I-24
D305	G-19	Q202	I-24
D307	G-18	Q203	I-18
D308	G-18	Q204	I-27
D309	G-27	Q205	J-28
D505	C-20	Q301	I-19
D506	D-20	Q302	H-19
D507	C-20	Q303	H-19
D508	D-20	Q304	H-19
D509	D-20	Q305	G-19
D701	I-11	Q306	J-22
D702	I-11	Q307	J-22
D703	I-15	Q308	G-24
D704	I-15	Q309	H-22
D705	I-11	Q310	G-25
D706	I-15	Q311	H-19
D707	H-11	Q313	G-18
D708	H-11	Q314	G-17
D709	J-11	Q315	G-18
D710	J-11	Q316	G-18
D711	J-11	Q317	G-18
D712	J-11	Q318	H-27
D713	H-10	Q319	H-27
D801	B-23	Q322	G-18
D802	B-23	Q323	G-28
D851	D-30	Q501	C-19
D861	D-30	Q502	D-19
D891	B-14	Q503	C-20
D892	D-14	Q504	E-20
		Q505	E-20
IC301	H-23	Q506	C-20
IC302	H-25	Q507	D-20
IC303	I-18	Q701	I-15
IC304	H-28	Q702	I-15
IC305	I-28	Q703	I-15
IC306	I-28	Q704	I-14
IC307	H-20	Q705	I-14
IC801	C-24	Q706	H-12
IC871	B-19	Q707	H-11
IC872	B-21	Q851	D-29
IC881	D-26	Q852	D-29
IC882	D-28	Q853	D-30
IC901	B-9	Q861	D-30
IC991	D-5	Q862	D-30
		Q883	D-25
		Q884	D-25
		Q885	D-28
		Q991	E-5

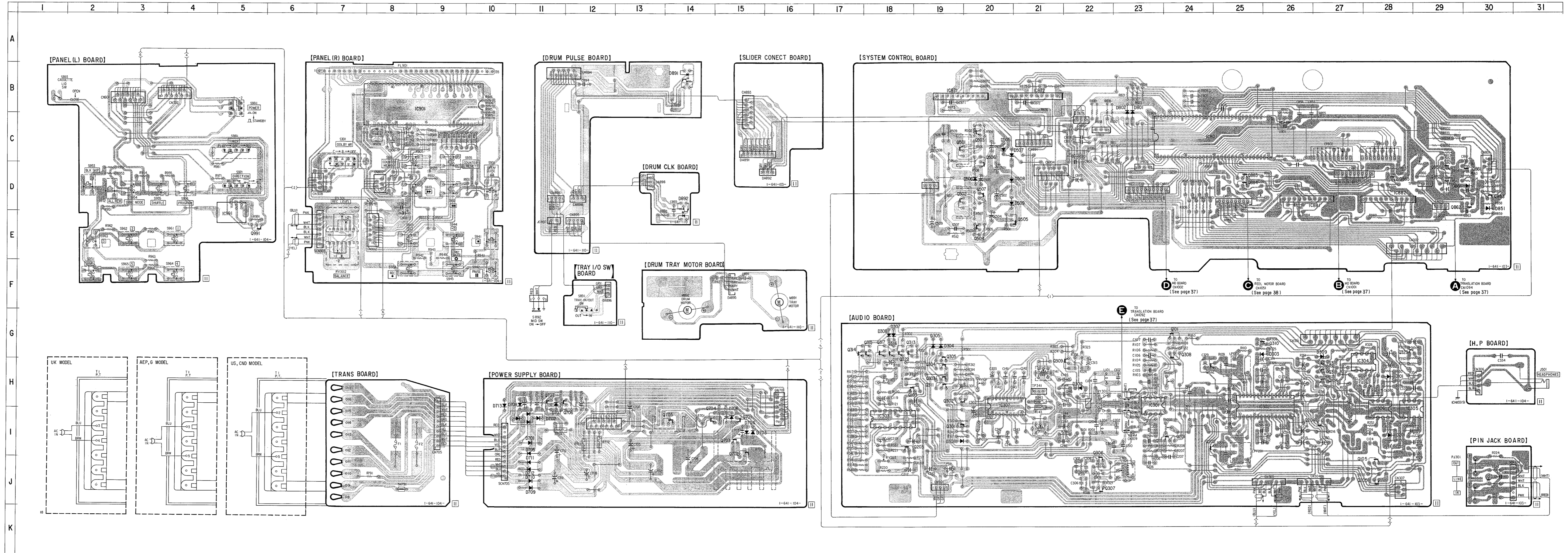

6-2. PRINTED WIRING BOARDS—AUDIO/SYSTEM CONTROL Section NEW TYPE—
(TC-C5/TC-C521)

• See page 33, 40 for Circuit Boards Location and Semiconductor Lead Layouts.

Note:
 ○ : parts extracted from the component side.
 ● : Pattern on the side which is seen.
 CND : Canadian
 G : Germany

● Semiconductor Location

Ref. No.	Location	Ref. No.	Location
D101	H-28	Q101	G-24
D201	I-28	Q102	H-24
D301	I-19	Q103	H-18
D302	H-22	Q104	H-27
D303	G-25	Q105	J-28
D304	G-19	Q201	I-24
D305	G-19	Q202	I-24
D307	G-18	Q203	I-18
D308	G-18	Q204	I-27
D309	G-27	Q205	J-28
D505	C-20	Q301	I-19
D506	D-20	Q302	H-19
D507	C-20	Q303	H-19
D508	D-20	Q304	H-19
D509	D-20	Q305	G-19
D701	I-11	Q306	J-22
D702	I-11	Q307	J-22
D703	I-15	Q308	G-24
D704	I-15	Q309	H-22
D705	I-11	Q310	G-25
D706	I-15	Q311	H-19
D707	H-11	Q313	G-18
D708	H-11	Q314	G-17
D709	J-11	Q315	G-18
D710	J-11	Q316	G-18
D711	J-11	Q317	G-18
D712	J-11	Q318	H-27
D713	H-10	Q319	H-27
D801	B-23	Q322	G-18
D802	B-23	Q323	G-28
D851	D-30	Q501	C-19
D861	D-30	Q502	D-19
D891	B-14	Q503	C-20
D892	D-14	Q504	E-20
		Q505	E-20
IC301	H-23	Q506	C-20
IC302	H-25	Q507	D-20
IC303	I-18	Q701	I-15
IC304	H-28	Q702	I-15
IC305	I-28	Q703	I-15
IC306	I-28	Q704	I-14
IC307	H-20	Q705	I-14
IC801	C-24	Q706	H-12
IC871	B-19	Q707	H-11
IC872	B-21	Q851	D-29
IC881	D-26	Q852	D-29
IC882	D-28	Q853	D-30
IC901	B-9	Q861	D-30
IC991	D-5	Q862	D-30
		Q883	D-25
		Q884	D-25
		Q885	D-28
		Q991	E-5

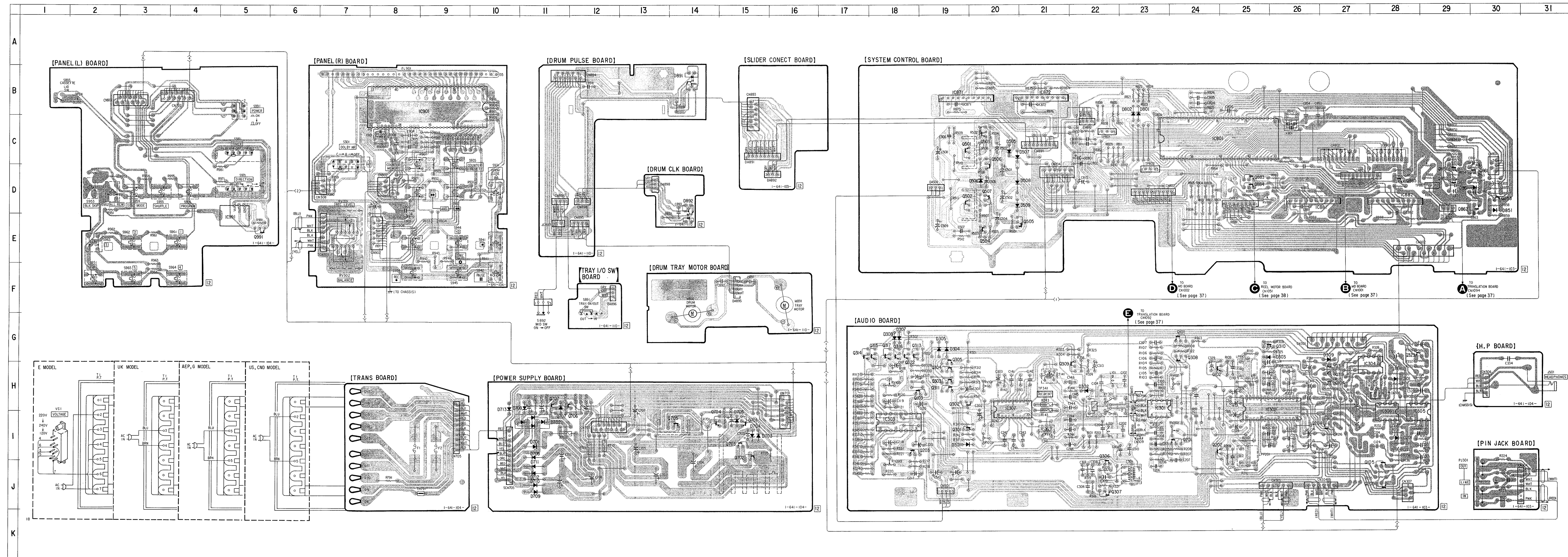

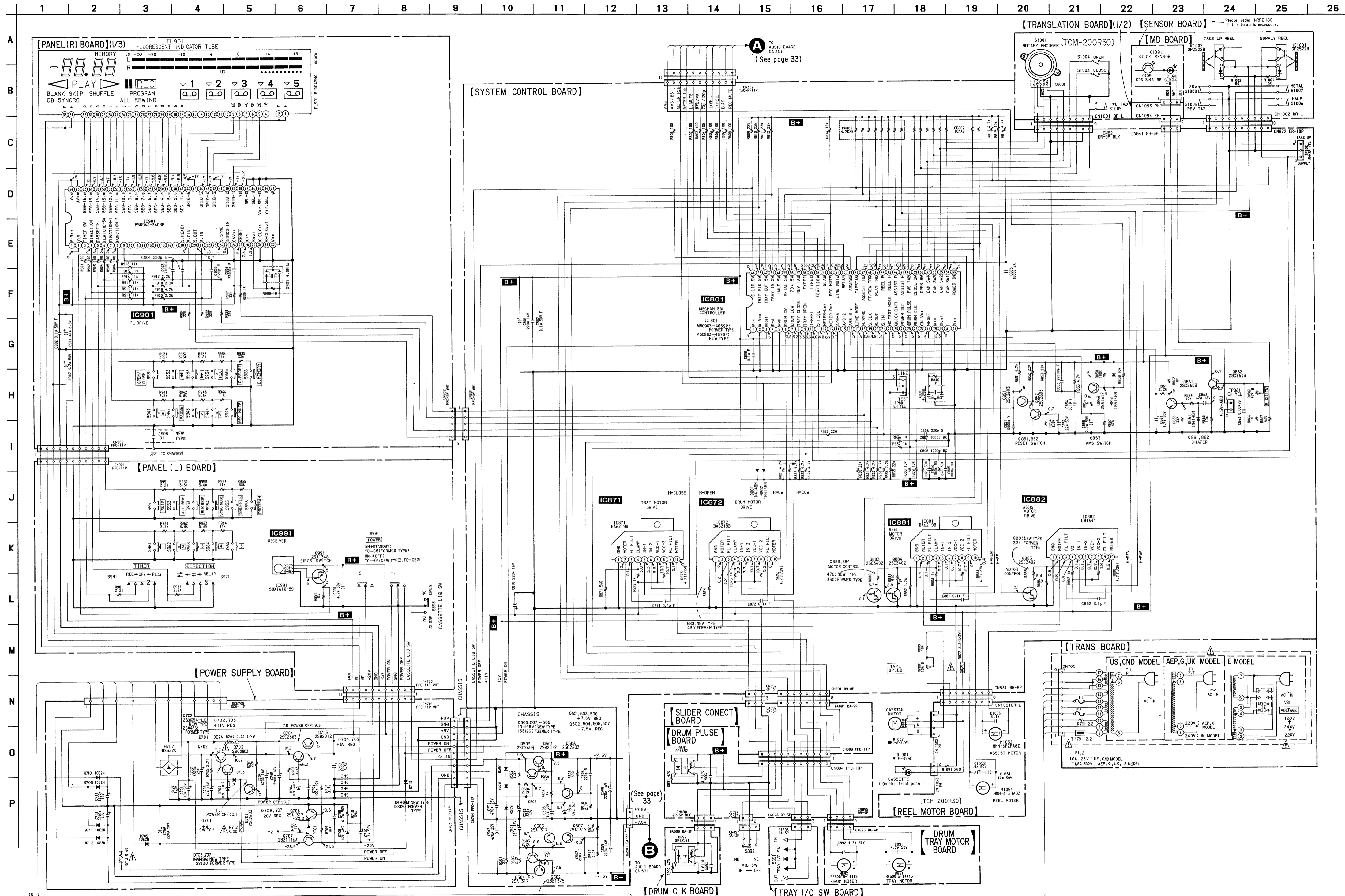

Note:

- All capacitors are in μF unless otherwise noted. pF: μF 50WV or less are not indicated except for electrolytics and tantalums.
- All resistors are in Ω and $1/4\text{W}$ or less unless otherwise specified.
- % : indicates tolerance.
- Δ : internal component.
- \sim : fusible resistor.

Note:
The components identified by mark Δ or dotted line with mark Δ are critical for safety. Replace only with part number specified.

Note:
Les composants identifiés par une marque Δ sont critiques pour la sécurité. Ne les remplacer que par une pièce portant le numéro spécifié.

- B+** : B+ Line
- B-** : B- Line
- no mark: STOP
- Voltages are taken with a VOM (Input Impedance 10M Ω). Voltage variations may be noted due to normal production tolerances.
- CND: Canadian
- G: Germany

● IC Block Diagram
IC882 LB1641
IC871, 872, 881 BA6219B

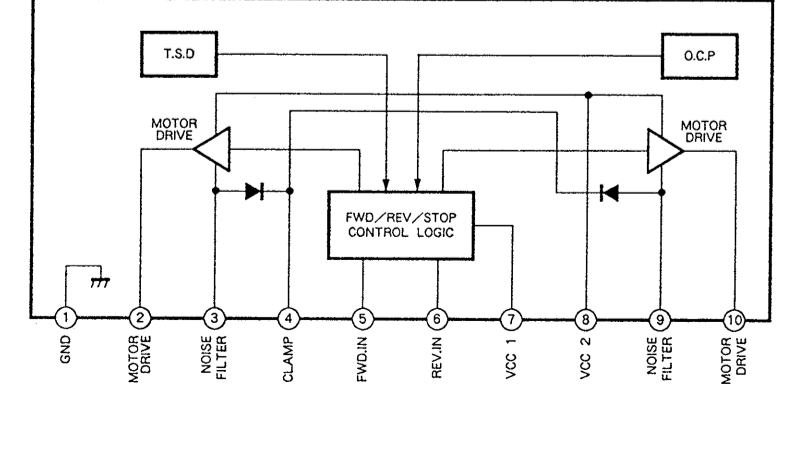

6-4. CIRCUIT BOARDS LOCATION

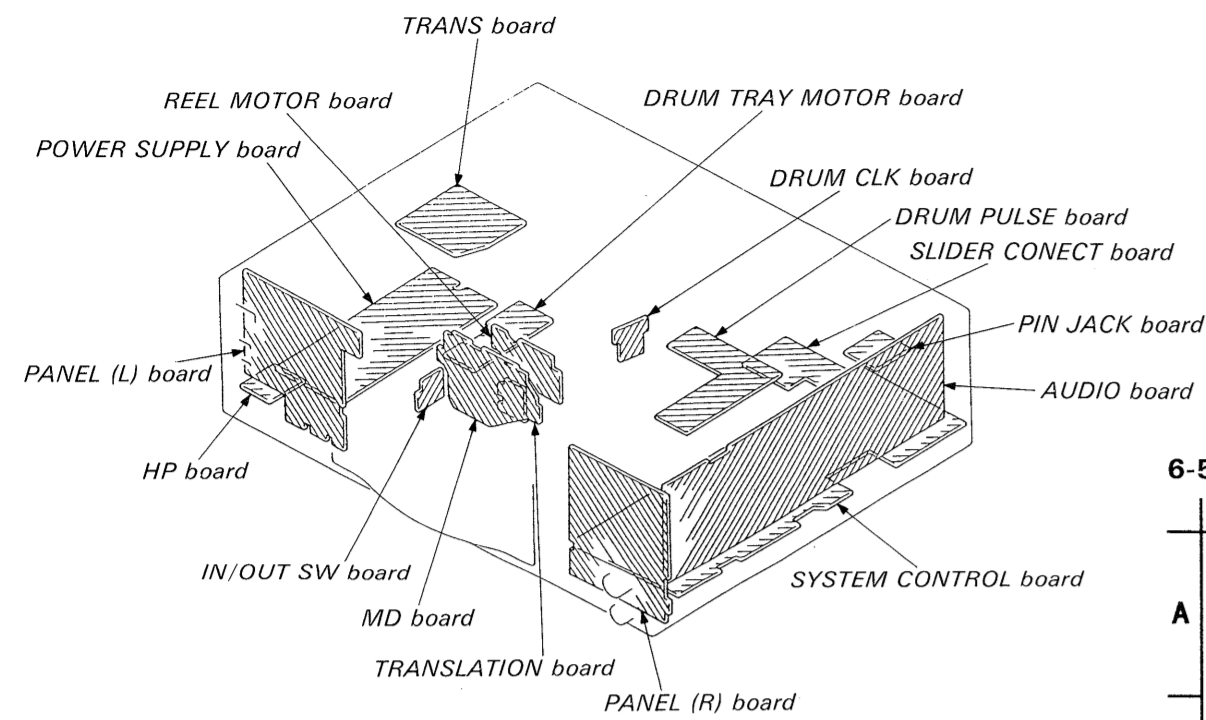

6-5. SCHEMATIC DIAGRAM—AUDIO Section—

1	2	3	4	5	6	7	8	9	10	11	12	13	14	15	16	17	18	19	20	21	22	23	24	25	26
---	---	---	---	---	---	---	---	---	----	----	----	----	----	----	----	----	----	----	----	----	----	----	----	----	----

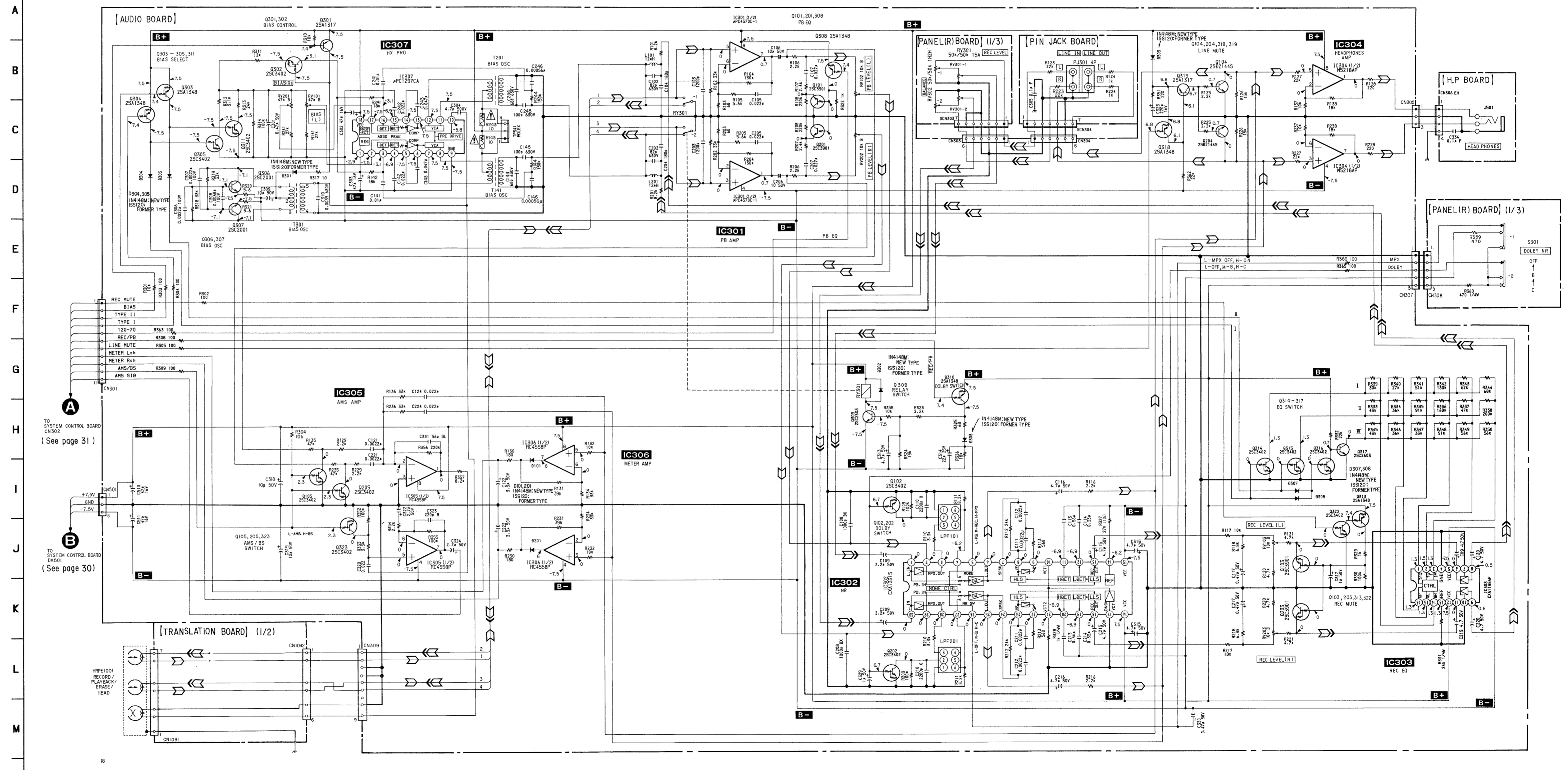

- Note:**
- All capacitors are in μF unless otherwise noted. pF : μF 50WV or less are not indicated except for electrolytics and tantalums.
 - All resistors are in Ω and $\frac{1}{2}W$ or less unless otherwise specified.
 - % : indicates tolerance.
 - --- : fusible resistor.
- Note:**
The components identified by mark Δ or dotted line with mark Δ are critical for safety. Replace only with part number specified.
- Note:**
Les composants identifiés par une marque Δ sont critiques pour la sécurité. Ne les remplacer que par une pièce portant le numéro spécifié.
- B+** : B+ Line
 - B-** : B- Line
 - --- : adjustment for repair.
 - no mark : STOP
 - Voltages are taken with a VOM (Input Impedance $10M\Omega$). Voltage variations may be noted due to normal production tolerances.
 - Signal path.
 - --- : PB
 - --- : REC

6-6. PRINTED WIRING BOARDS—TC SECTION—

• See page 33, 40 for Circuit Boards Location and Semiconductor Lead Layouts.

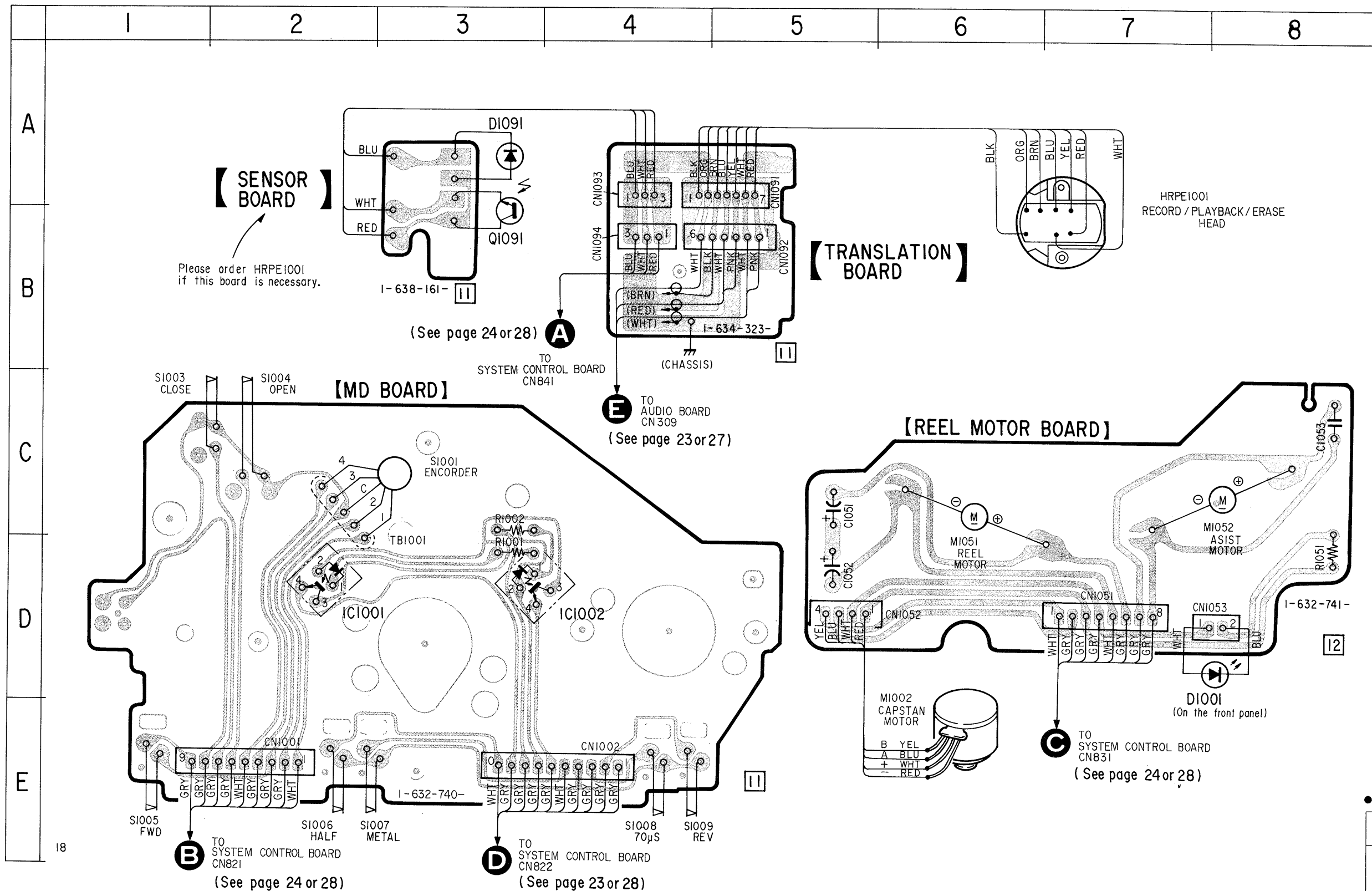

• Semiconductor Location

Ref. No.	Location
D1001	D-8
D1091	A-3
IC1001	D-2
IC1002	D-3
Q1091	B-3

Note:
 • — : parts extracted from the component side.
 • : Pattern on the side which is seen.

• Fluorescent Indicator Tube

FL 901
FLUORESCENT INDICATOR TUBE

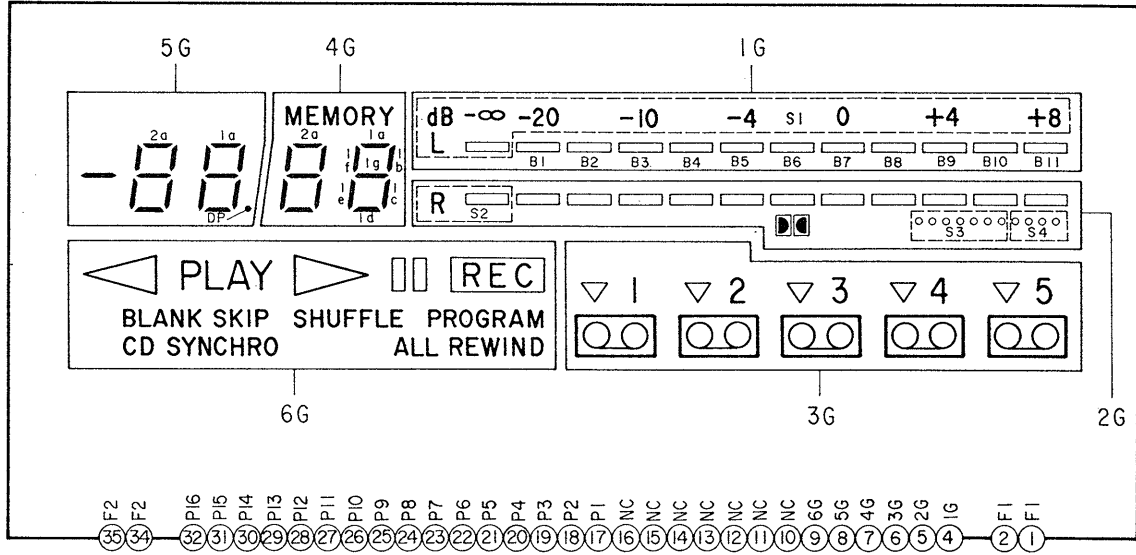

ANODE CONNECTION

	6G	5G	4G	3G	2G	1G
P1	▷	1a	1a	▽ (1)	S2	S1
P2	PLAY	1b	1b	1	B1	B1
P3	▷	1c	1c	□□ (1)	B2	B2
P4	□□	1d	1d	▽ (2)	B3	B3
P5	REC	1e	1e	2	B4	B4
P6	—	1f	1f	□□ (2)	B5	B5
P7	—	1g	1g	▽ (3)	B6	B6
P8	—	DP	—	3	B7	B7
P9	BLANK SKIP	2a	2a	□□ (3)	□□	—
P10	SHUFFLE	2b	2b	▽ (4)	B8	B8
P11	PROGRAM	2c	2c	4	B9	B9
P12	—	2d	2d	□□ (4)	B10	B10
P13	CD SYNCHRO	2e	2e	▽ (5)	B11	B11
P14	ALL REWIND	2f	2f	5	S3	—
P15	—	2g	2g	□□ (5)	S4	—
P16	—	—	MEMORY	—	—	—

● Semiconductor Lead Layouts

BA6219B
LB1641

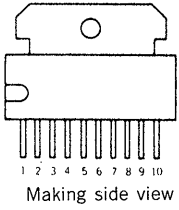

2SA473
2SB1094-LK
2SD2012

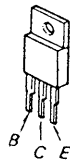

UZL-11H2
1N4148M
1SS120
10E2N

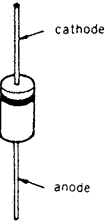

GP2S22B

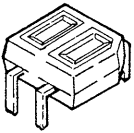

2SB1116A-L
2SC2001-M

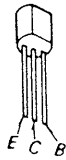

SLR314D

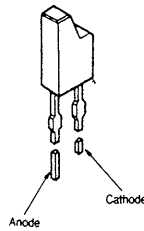

SBX1610-59

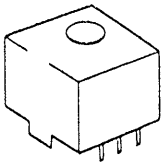

D2SB20

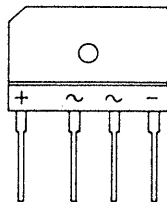

DTA114ES
DTC114ES
DTC143TS
2SA1317-STU
2SC2603-EF
2SD2144S

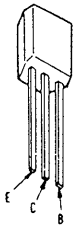
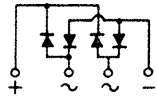

HZS6A1L
HZS6B3L
HZS6C3L

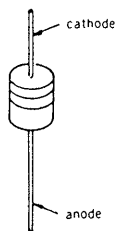

SECTION 7 EXPLODED VIEWS

NOTE:

- -XX, -X mean standardized parts, so they may have some differences from the original one.
- Color Indication of Appearance Parts.
Example:
KNOB, BALANCE(WHITE)...(RED)
 ↑ ↑
 Parts color Cabinet's color

- Items marked " * " are not stocked since they are seldom required for routine service. Some delay should be anticipated when ordering these items.
- The mechanical parts with no reference number in the exploded views are not supplied.
- hardware (#mark) list is given in the last of this parts list.
- C5 :TC-C5 • G : Germany
- C521 : TC-C521 • CND : Canadian

The components identified by mark or dotted line with mark are critical for safety. Replace only with part number specified.

Les composants identifiés par une marque sont critiques pour la sécurité. Ne les remplacer que par une pièce portant le numéro spécifié.

7-1. DRUM SECTION

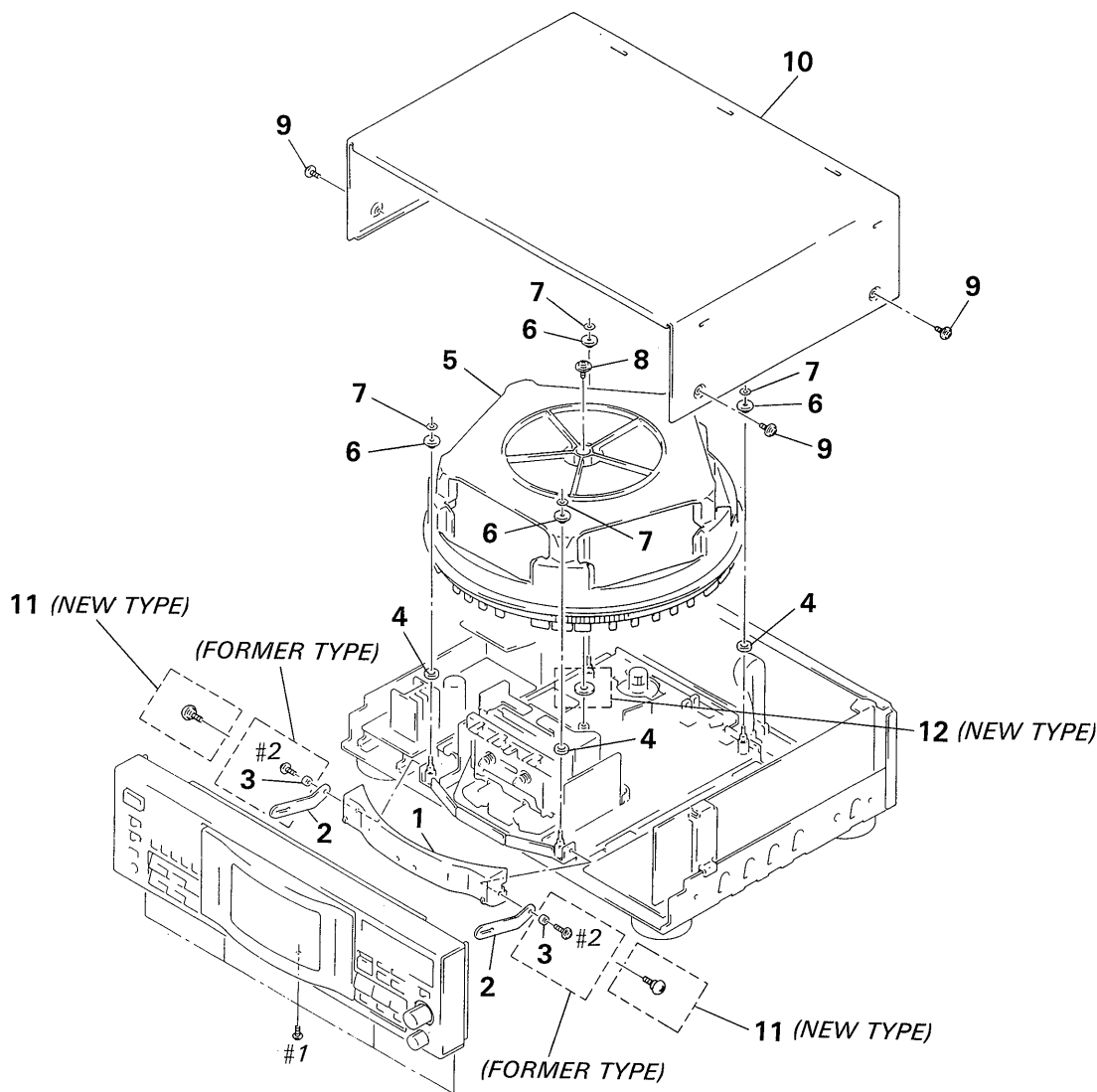

Ref. No.	Part No.	Description	Remark	Ref. No.	Part No.	Description	Remark
1	3-372-439-01	COVER		7	3-558-708-21	WASHER, STOPPER	
* 2	3-372-729-01	LEVER (HINGE)		8	3-372-528-01	SCREW (M3X6), SPECIAL	
3	3-372-773-01	COLLAR (FORMER TYPE)		9	3-704-366-01	SCREW (CASE) (M3X8)	
4	3-372-530-01	ROLLER (DRUM B)		10	4-925-039-61	CASE	
* 5	3-372-532-01	DRUM		11	3-372-732-01	SCREW (BVTT2.6), STEP (NEW TYPE)	
6	3-372-529-01	ROLLER (DRUM)		12	3-373-916-01	WASHER (CENTER) (NEW TYPE)	

7-2. FRONT PANEL SECTION

- A : PANEL (R) board
- B : HP board
- C-D : See page 44.

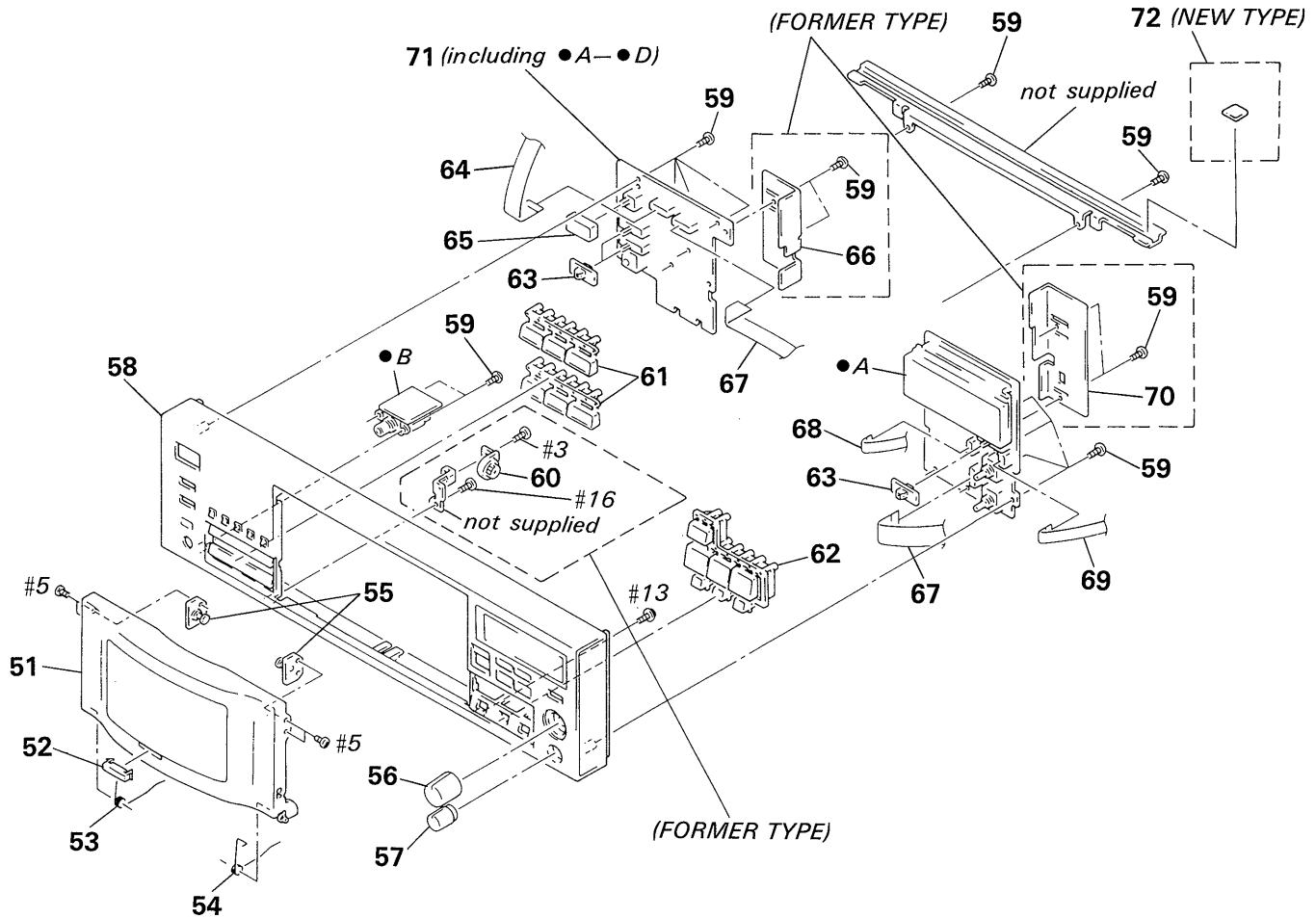

Ref. No.	Part No.	Description	Remark
51	X-3363-664-1	LID ASSY, CASSETTE	
52	3-372-474-01	PLATE (A), ORNAMENTAL	
53	3-372-472-01	SPRING (L), TORSION	
54	3-372-473-01	SPRING (R), TORSION	
* 55	X-3363-691-1	BRACKET (HINGE) ASSY	
56	4-927-863-01	KNOB (R18)	
57	3-349-039-11	KNOB (VOL)	
58	X-3363-663-1	PANEL ASSY, FRONT (C5/US, CND)	
58	X-3363-665-1	PANEL ASSY, FRONT (AEP, G, UK, E)	
58	X-3365-165-1	PANEL ASSY, FRONT (C521)	
59	4-928-635-01	SCREW, +BV (2. 6X8) TAPPING	

Ref. No.	Part No.	Description	Remark
60	3-354-963-01	DAMPER (FORMER TYPE)	
61	3-372-462-01	BUTTON (B)	
62	3-372-464-01	BUTTON (D)	
63	4-931-421-11	KNOB (T & S)	
64	1-534-517-00	WIRE, FLAT TYPE (11 CORE)	
65	4-922-921-01	BUTTON (POWER)	
* 66	3-372-476-01	COVER (L) (FORMER TYPE)	
67	1-690-319-11	WIRE, FLAT TYPE (11 CORE)	
68	1-575-779-11	WIRE, FLAT TYPE (5 CORE)	
69	1-575-778-11	WIRE, FLAT TYPE (5 CORE)	
* 70	3-372-477-01	COVER (R) (FORMER TYPE)	
* 71	A-2006-621-A	PANEL POWER BOARD, COMPLETE	
72	9-911-830-XX	SHEET, HB (NEW TYPE)	

7-3. SLIDER SECTION

- ▲A : DRUM TRAY MOTOR board
- ▲B : DRUM CLK board
- ▲C : IN/OUT SW board

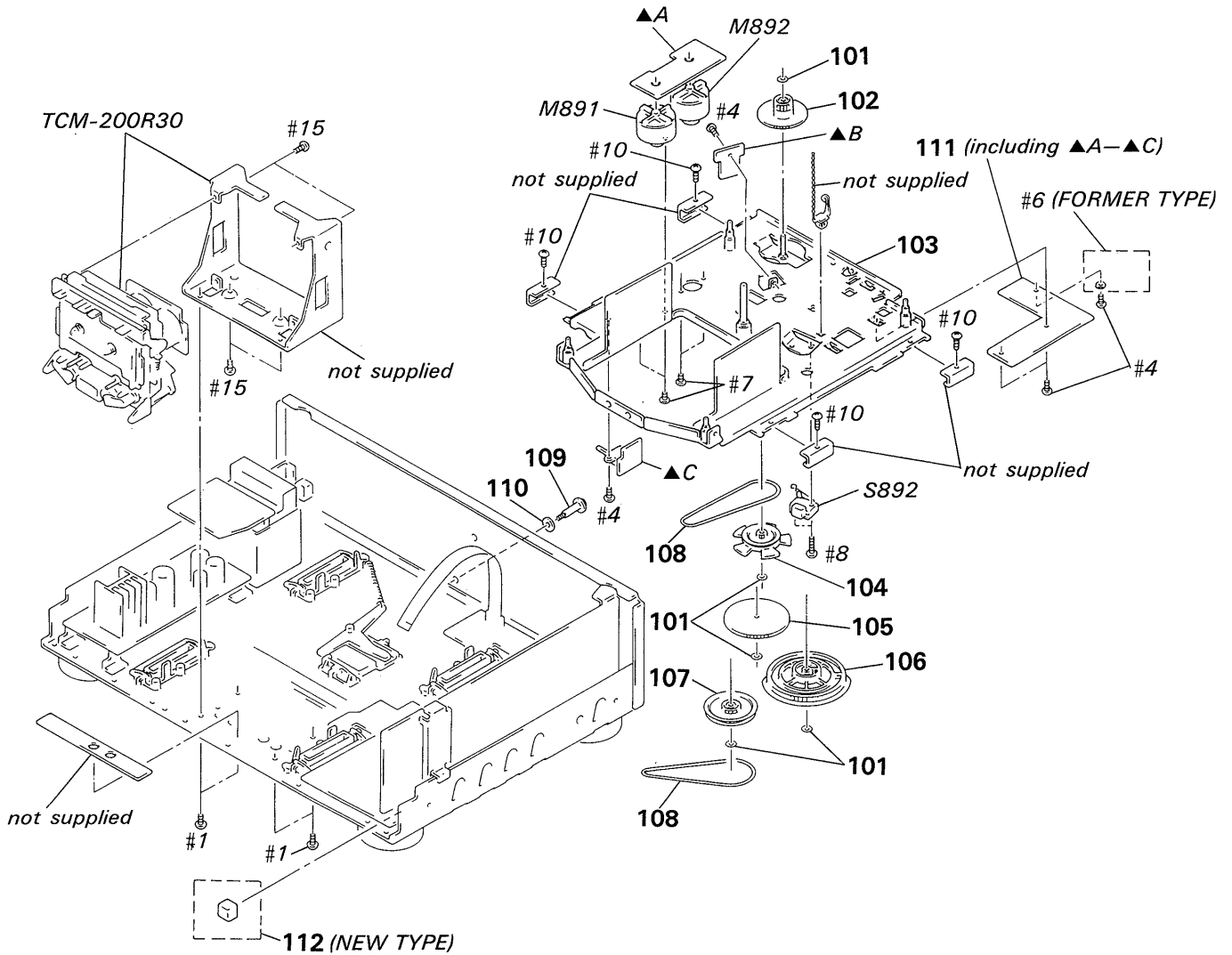

Ref. No.	Part No.	Description	Remark
101	3-558-708-21	WASHER, STOPPER	
102	3-372-519-01	GEAR (ROTARY)	
* 103	X-3363-668-1	SLIDER ASSY	
104	3-372-518-01	PULLEY (ROTARY)	
105	3-372-517-01	GEAR (LOADING)	
106	3-372-515-01	GEAR (CAM GEAR)	
107	3-372-516-01	PULLEY (LOADING)	
108	3-372-514-01	BELT (LOADING) (FORMER TYPE)	
108	3-375-149-01	BELT (B) (NEW TYPE)	

Ref. No.	Part No.	Description	Remark
109	3-372-531-01	SCREW, TRANSPORT	
110	3-375-420-01	WASHER (TRANSPORT SCREW) (NEW TYPE)	
110	4-930-282-01	WASHER (T), POLY-SLIDER (FORMER TYPE)	
* 111	1-641-110-11	SLIDER BOARD	
* 112	3-346-279-01	CUSHION (P) (NEW TYPE)	
M891	X-3363-669-1	MOTOR (TRAY) ASSY	
M892	X-3363-669-1	MOTOR (DRUM) ASSY (NEW TYPE)	
M892	X-3363-670-1	MOTOR (DRUM) ASSY (FORMER TYPE)	
S892	1-572-713-11	SWITCH, PUSH (WITH CONNECTOR) (MID)	

7-4. CHASSIS SECTION

- C : POWER SUPPLY board
- D : TRANS board
- A : AUDIO board
- B : SLIDER CONECT board
- C : PIN JACK board
- D : WIRE HOLDER board

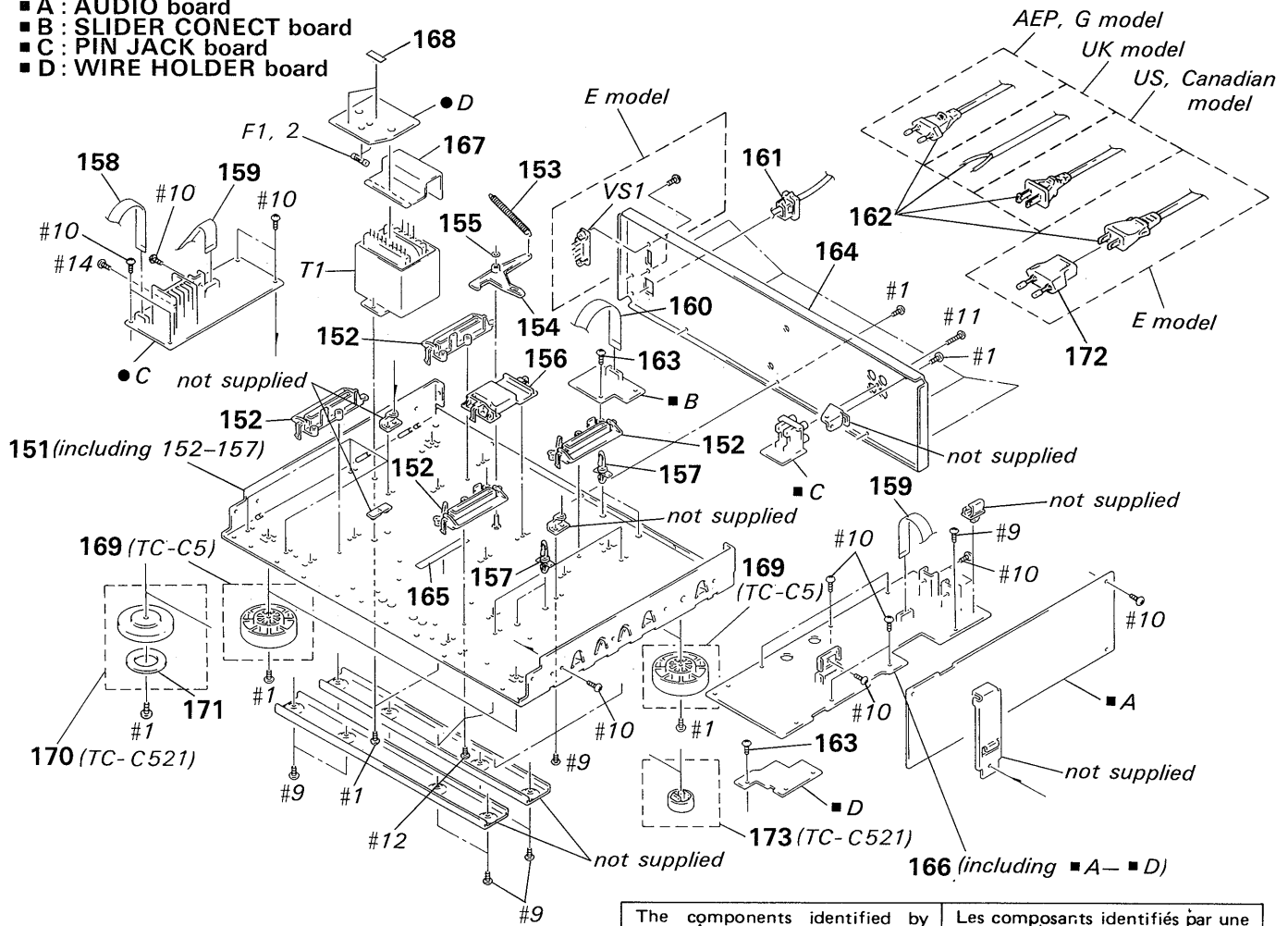

<p>The components identified by mark \triangle or dotted line with mark \triangle are critical for safety. Replace only with part number specified.</p>	<p>Les composants identifiés par une marque \triangle sont critiques pour la sécurité. Ne les remplacer que par une pièce portant le numéro spécifié.</p>
---	--

Ref. No.	Part No.	Description	Remark
* 151	X-3363-671-1	CHASSIS ASSY	
152	3-372-521-01	RAIL, GUIDE	
153	3-372-525-01	SPRING, TENSION	
154	3-372-523-01	LEVER (LOADING)	
155	3-558-708-21	WASHER, STOPPER	
156	3-372-522-01	RACK	
* 157	4-924-098-21	HOLDER, PC BOARD	
158	1-534-517-00	WIRE, FLAT TYPE (11 CORE)	
159	1-690-320-11	WIRE, FLAT TYPE (11 CORE)	
160	1-534-517-00	WIRE, FLAT TYPE (11 CORE)	
* 161	3-703-244-00	BUSHING (2104), CORD (EXCEPT FOR E)	
* 161	3-703-571-11	BUSHING (S) (4516), CORD (E)	
\triangle 162	1-551-188-XX	CORD, POWER (E)	
\triangle 162	1-555-465-00	CORD, POWER (C5/US, CND)	
\triangle 162	1-555-795-00	CORD, POWER, EULO PLUG (AEP, G)	
\triangle 162	1-556-035-00	CORD, POWER (UK)	
\triangle 162	1-590-836-31	CORD, POWER (C521)	
163	4-928-635-01	SCREW, +BV (2.6X8) TAPPING	
* 164	3-371-137-01	PANEL, BACK (C5/US, CND)	
* 164	3-371-137-11	PANEL, BACK (AEP)	
* 164	3-371-137-21	PANEL, BACK (G)	
* 164	3-371-137-31	PANEL, BACK (UK)	

Ref. No.	Part No.	Description	Remark
* 164	3-371-137-51	PANEL, BACK (E)	
* 164	3-380-030-01	PANEL, BACK (C521)	
165	3-831-441-XX	CUSHION (B), CABINET	
* 166	A-2006-620-A	AUDIO SYSCON BOARD, COMPLETE	
* 167	3-337-136-11	COVER, TRANSFORMER SAFETY (AEP, G, UK, E)	
* 167	3-372-475-01	COVER (TRANSFORMER) (US, CND)	
* 168	3-701-947-13	LABEL (T1. 6A), FUSE (AEP, G, UK, E)	
* 168	3-703-044-26	LABEL, CAUTION (US)	
169	4-943-148-32	FOOT (F58175SW) (C5/US, CND)	
169	4-943-148-42	FOOT (F58175SW) (AEP, G, UK, E)	
170	X-4911-201-1	FOOT ASSY (C521)	
171	4-923-836-11	CUSHION (C521)	
\triangle 172	1-569-007-11	ADAPTER, CONVERSION 2P (E)	
173	4-933-601-01	FOOT (C521)	
\triangle F1	1-532-259-00	FUSE, TIME-LAG T1. 6A 250V (AEP, G, UK, E)	
\triangle F1	1-532-742-11	FUSE, GLASS TUBE 1. 6A 125V (US, CND)	
\triangle F2	1-532-259-00	FUSE, TIME-LAG T1. 6A 250V (AEP, G, UK, E)	
\triangle F2	1-532-742-11	FUSE, GLASS TUBE 1. 6A 125V (US, CND)	
\triangle T1	1-450-444-11	TRANSFORMER, POWER (US, CND)	
\triangle T1	1-450-445-11	TRANSFORMER, POWER (E)	
\triangle T1	1-450-446-11	TRANSFORMER, POWER (AEP, G, UK)	
\triangle VS1	1-692-155-11	SELECTOR, POWER VOLTAGE (VOLTAGE) (E)	

7-5. MECHANISM SECTION 1
(TCM-200R30)

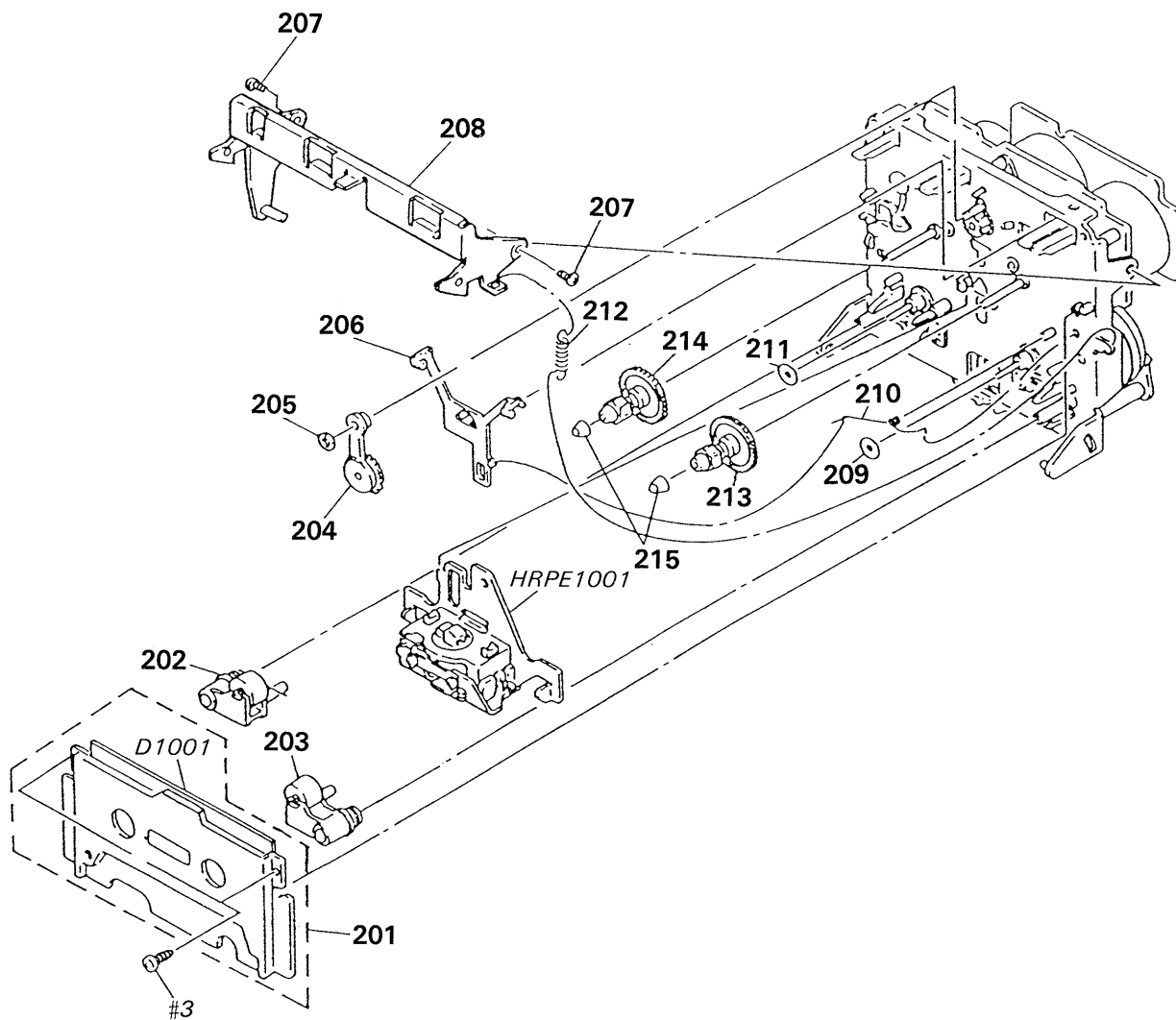

Ref. No.	Part No.	Description	Remark
201	X-3356-613-1	PLATE ASSY, ORNAMENTAL	
202	X-3343-456-1	LEVER (PINCH R) ASSY	
203	X-3343-455-1	LEVER (PINCH F) ASSY	
204	X-3356-641-1	LEVER (FR2) ASSY	
205	3-669-465-11	WASHER (1.5), STOPPER	
206	3-356-614-01	SLIDER (BRAKE)	
207	3-356-601-11	SCREW, STEP	
208	X-3363-367-1	LEVER (LIFTER) ASSY	
209	3-356-713-01	WASHER	

Ref. No.	Part No.	Description	Remark
210	3-356-619-01	SPRING (B), TORSION	
211	3-356-714-01	WASHER	
212	3-356-625-01	SPRING, TENSION	
213	X-3356-627-1	GEAR (A) ASSY	
214	X-3356-628-1	GEAR (S) ASSY	
215	3-362-308-01	CAP (REEL)	
D1001	8-719-980-85	LED SLF325C (CASSETE)	
HRPE	A-2003-722-A	DECK ASSY, HEAD (This parts, if ordered, contains the SENSOR board.)	
1001			

7-6. MECHANISM SECTION 2
(TCM-200R30)

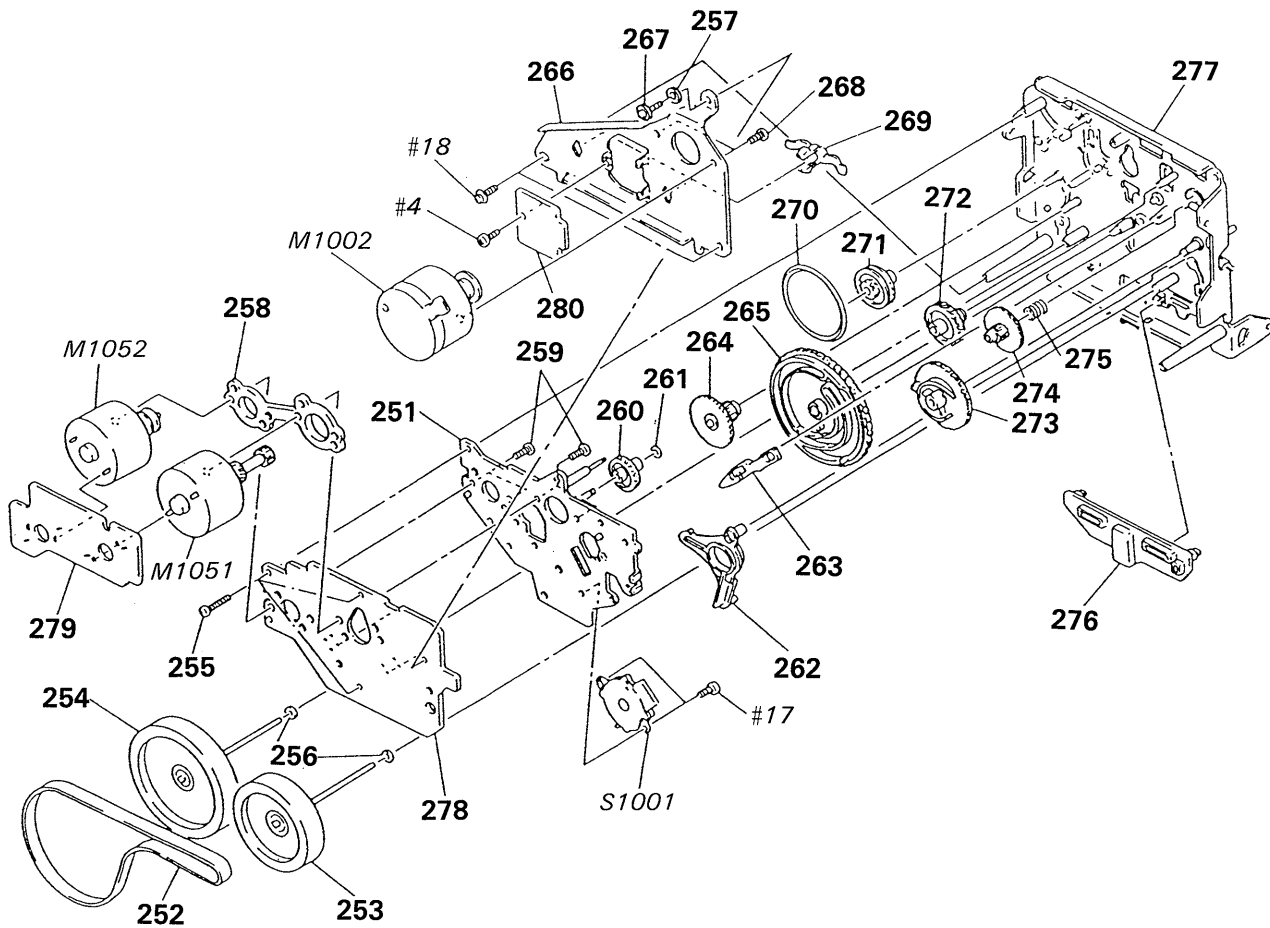

Ref. No.	Part No.	Description	Remark
* 251	X-3356-602-1	BRACKET (MOTOR R) ASSY	
252	3-356-604-01	BELT (CAPSTAN)	
253	X-3363-363-1	FLYWHEEL (R FWD) ASSY	
254	X-3363-364-1	FLYWHEEL (R REV) ASSY	
255	3-355-801-01	SCREW (BTP 2X18)	
256	3-356-705-01	WASHER (CAPSTAN)	
* 257	3-356-718-01	SPACER (THRUST RETAINER R)	
* 258	3-356-628-01	SPACER (MOTOR)	
259	3-363-804-01	SCREW (+P 2.6X6.5)	
260	3-356-702-01	GEAR (COMMUNICATION B)	
261	3-669-465-00	WASHER (1.5), STOPPER	
262	3-356-613-01	LEVER (MODE)	
263	3-356-617-01	LEVER (SELECTION)	
264	3-356-606-01	GEAR (MODE)	
265	3-356-615-01	GEAR (MODE CAM RR)	
* 266	3-356-629-01	BRACKET (THRUST RETAINER R)	
267	3-356-707-01	SCREW (+PTPWH 2X25)	

Ref. No.	Part No.	Description	Remark
268	4-885-599-00	SCREW, FITTING, REINFORCEMENT	
269	3-575-321-00	RETAINER, THRUST, CAPSTAN	
270	3-356-603-01	BELT (MODE)	
271	3-356-607-01	PULLEY (MODE)	
272	3-356-703-01	GEAR (COMMUNICATION C)	
273	3-356-616-01	GEAR (LOADING CAM)	
274	3-356-609-01	GEAR (LOADING)	
275	3-356-605-01	SPRING, COMPRESSION	
276	3-356-612-01	SLIDER (REVERSE)	
277	X-3363-365-1	CHASSIS (R30) COMPLETE ASSY	
* 278	1-632-740-11	MD BOARD	
* 279	1-632-741-11	REEL MOTOR BOARD	
* 280	1-634-323-11	TRANSLATION BOARD	
M1002	X-3365-002-1	MOTOR (CAPSTAN R30) ASSY	
M1051	X-3356-638-1	MOTOR (REEL R) ASSY	
M1052	X-3356-604-1	MOTOR (ASSIST) ASSY	
S1001	1-466-525-11	ENCODER, ROTARY	

SECTION 8 ELECTRICAL PARTS LIST

AUDIO SYSCON

NOTE:

- Due to standardization, replacements in the parts list may be different from the parts specified in the diagrams or the components used on the set.
- -XX and -X mean standardized parts, so they may have some difference from the original one.
- RESISTORS
All resistors are in ohms.
METAL: Metal-film resistor.
METAL OXIDE: Metal oxide-film resistor.
F: nonflammable

- Items marked "*" are not stocked since they are seldom required for routine service. Some delay should be anticipated when ordering these items.
- SEMICONDUCTORS
In each case, u: μ , for example:
uA ..: μ A. uPA..: μ PA.
uPB..: μ PB.. uPC..: μ PC.. uPD..: μ PD..
- CAPACITORS
uF: μ F
- COILS
uH: μ H
- C5:TC-C5 C521:TC-C521 CND:Canadian G:Germany

When indication parts by reference number, please include the board name.

The components identified by mark Δ or dotted line with mark Δ are critical for safety. Replace only with part number specified.

Les composants identifiés par une marque Δ sont critiques pour la sécurité. Ne les remplacer que par une pièce portant le numéro spécifié.

Ref. No.	Part No.	Description	Remark	Ref. No.	Part No.	Description	Remark
*	A-2006-620-A	AUDIO SYSCON BOARD, COMPLETE (including SYSTEM CONTROL BOARD, AUDIO BOARD, SLIDER CONECT BOARD, PIN JACK BOARD) *****		C144	1-136-272-00	FILM 68PF 5% 630V	
				C145	1-136-433-11	FILM 100PF 5% 630V	
				C146	1-130-468-00	MYLAR 560PF 5% 50V	
				C202	1-136-274-11	FILM 82PF 5% 630V	
				C203	1-164-736-31	CERAMIC 0.0012uF 10% 50V	
*	3-309-144-21	HEAT SINK		C204	1-162-285-31	CERAMIC 180PF 10% 50V	
*	3-346-266-12	PLATE, GROUND		C205	1-136-157-00	FILM 0.022uF 5% 50V	
*	3-356-925-01	HEAT SINK		C206	1-124-657-00	ELECT 10uF 20% 50V	
	7-682-547-04	SCREW +BVTT 3X6 (S)		C207	1-136-158-00	FILM 0.027uF 5% 50V	
		< CAPACITOR >		C208	1-162-294-31	CERAMIC 0.001uF 10% 50V	
	C102	1-136-274-11	FILM 82PF 5% 630V	C209	1-124-925-11	ELECT 2.2uF 20% 100V	
	C103	1-164-736-31	CERAMIC 0.0012uF 10% 50V	C210	1-161-375-00	CERAMIC 0.0022uF 20% 50V	
	C104	1-162-285-31	CERAMIC 180PF 10% 50V	C211	1-130-475-00	MYLAR 0.0022uF 5% 50V	
	C105	1-136-157-00	FILM 0.022uF 5% 50V	C212	1-130-475-00	MYLAR 0.0022uF 5% 50V	
	C106	1-124-657-00	ELECT 10uF 20% 50V	C213	1-136-174-00	FILM 0.56uF 5% 50V	
	C107	1-136-158-00	FILM 0.027uF 5% 50V	C214	1-136-171-00	FILM 0.33uF 5% 50V	
	C108	1-162-294-31	CERAMIC 0.001uF 10% 50V	C215	1-124-927-11	ELECT 4.7uF 20% 100V	
	C109	1-124-925-11	ELECT 2.2uF 20% 100V	C216	1-124-927-11	ELECT 4.7uF 20% 100V	
	C110	1-161-375-00	CERAMIC 0.0022uF 20% 50V	C217	1-124-902-00	ELECT 0.47uF 20% 50V	
	C111	1-130-475-00	MYLAR 0.0022uF 5% 50V	C219	1-124-927-11	ELECT 4.7uF 20% 100V	
	C112	1-130-475-00	MYLAR 0.0022uF 5% 50V	C220	1-124-927-11	ELECT 4.7uF 20% 100V	
	C113	1-136-174-00	FILM 0.56uF 5% 50V	C221	1-130-475-00	MYLAR 0.0022uF 5% 50V	
	C114	1-136-171-00	FILM 0.33uF 5% 50V	C222	1-123-382-00	ELECT 3.3uF 20% 100V	
	C115	1-124-927-11	ELECT 4.7uF 20% 100V	C224	1-136-157-00	FILM 0.022uF 5% 50V	
	C116	1-124-927-11	ELECT 4.7uF 20% 100V	C241	1-136-153-00	FILM 0.01uF 5% 50V	
	C117	1-124-902-00	ELECT 0.47uF 20% 50V	C242	1-136-157-00	FILM 0.022uF 5% 50V	
	C119	1-124-927-11	ELECT 4.7uF 20% 100V	C243	1-136-161-00	FILM 0.047uF 5% 50V	
	C120	1-124-927-11	ELECT 4.7uF 20% 100V	C244	1-136-272-00	FILM 68PF 5% 630V	
	C121	1-130-475-00	MYLAR 0.0022uF 5% 50V	C245	1-136-433-11	FILM 100PF 5% 630V	
	C122	1-123-382-00	ELECT 3.3uF 20% 100V	C246	1-130-468-00	MYLAR 560PF 5% 50V	
	C124	1-136-157-00	FILM 0.022uF 5% 50V	C301	1-124-902-00	ELECT 0.47uF 20% 50V	
	C141	1-136-153-00	FILM 0.01uF 5% 50V	C302	1-124-477-11	ELECT 47uF 20% 25V	
	C142	1-136-157-00	FILM 0.022uF 5% 50V	C303	1-124-477-11	ELECT 47uF 20% 25V	
	C143	1-136-161-00	FILM 0.047uF 5% 50V	C304	1-107-046-00	MICA 4.7PF 500V	

AUDIO SYSCON

Ref. No.	Part No.	Description			Remark	Ref. No.	Part No.	Description			Remark
C305	1-164-159-11	CERAMIC	0. 1uF		50V	C863	1-130-479-00	MYLAR	0. 0047uF	5%	50V
C306	1-136-230-00	FILM	0. 0022uF	5%	100V	C871	1-164-159-11	CERAMIC	0. 1uF		50V
C307	1-136-230-00	FILM	0. 0022uF	5%	100V	C872	1-164-159-11	CERAMIC	0. 1uF		50V
C308	1-130-856-00	FILM	0. 0068uF	5%	100V	C881	1-164-159-11	CERAMIC	0. 1uF		50V
C309	1-124-907-11	ELECT	10uF	20%	50V	C882	1-164-159-11	CERAMIC	0. 1uF		50V
C310	1-136-558-11	FILM	0. 0039uF	5%	630V			< CONNECTOR >			
C313	1-124-927-11	ELECT	4. 7uF	20%	100V	* CN301	1-573-979-11	CONNECTOR, BOARD TO BOARD	11P		
C314	1-126-233-11	ELECT	22uF	20%	50V	* CN302	1-573-978-11	CONNECTOR, BOARD TO BOARD	11P		
C315	1-124-927-11	ELECT	4. 7uF	20%	100V	* CN303	1-564-509-11	PLUG, CONNECTOR	6P		
C316	1-124-927-11	ELECT	4. 7uF	20%	100V	* CN304	1-564-509-11	PLUG, CONNECTOR	6P		
C317	1-124-903-11	ELECT	1uF	20%	50V	* CN305	1-564-506-11	PLUG, CONNECTOR	3P		
C318	1-124-907-11	ELECT	10uF	20%	50V						
C319	1-124-907-11	ELECT	10uF	20%	50V	* CN307	1-568-824-11	SOCKET, CONNECTOR	5P		
C320	1-136-157-00	FILM	0. 022uF	5%	50V	* CN309	1-564-512-11	PLUG, CONNECTOR	9P		
C322	1-124-925-11	ELECT	2. 2uF	20%	100V	* CN501	1-564-337-61	PIN, CONNECTOR	3P		
C323	1-162-286-31	CERAMIC	220PF	10%	50V	* CN704	1-568-830-11	SOCKET, CONNECTOR	11P		
C324	1-124-925-11	ELECT	2. 2uF	20%	100V	* CN801	1-568-824-11	SOCKET, CONNECTOR	5P		
C325	1-124-120-11	ELECT	220uF	20%	25V						
C329	1-124-903-11	ELECT	1uF	20%	50V	* CN821	1-506-503-61	PIN, CONNECTOR	9P		
C330	1-124-902-00	ELECT	0. 47uF	20%	50V	* CN822	1-564-666-11	PIN, CONNECTOR	10P		
C331	1-162-217-31	CERAMIC	56PF	5%	50V	* CN831	1-564-342-11	PIN, CONNECTOR	8P		
C501	1-124-480-11	ELECT	470uF	20%	25V	* CN841	1-564-705-11	PIN, CONNECTOR (SMALL TYPE)	3P		
C502	1-124-480-11	ELECT	470uF	20%	25V	* CN891	1-564-342-11	PIN, CONNECTOR	8P		
C503	1-124-120-11	ELECT	220uF	20%	25V						
C504	1-124-120-11	ELECT	220uF	20%	25V	* CN892	1-564-337-00	PIN, CONNECTOR	3P		
C505	1-124-925-11	ELECT	2. 2uF	20%	100V	* CN893	1-568-830-11	SOCKET, CONNECTOR	11P		
C506	1-162-286-31	CERAMIC	220PF	10%	50V			< COMPOSITION CIRCUIT BLOCK >			
C507	1-162-286-31	CERAMIC	220PF	10%	50V	CP801	1-233-204-11	COMPOSITION CIRCUIT BLOCK			
C508	1-124-120-11	ELECT	220uF	20%	25V	CP802	1-233-199-11	COMPOSITION CIRCUIT BLOCK			
C509	1-124-120-11	ELECT	220uF	20%	25V			< DIODE >			
C510	1-124-477-11	ELECT	47uF	20%	25V	D101	8-719-987-63	DIODE	1N4148M (NEW TYPE)		
C511	1-124-477-11	ELECT	47uF	20%	25V	D101	8-719-912-20	DIODE	1SS120 (FORMER TYPE)		
C801	1-124-120-11	ELECT	220uF	20%	25V	D201	8-719-987-63	DIODE	1N4148M (NEW TYPE)		
C802	1-164-159-11	CERAMIC	0. 1uF		50V	D201	8-719-912-20	DIODE	1SS120 (FORMER TYPE)		
C803	1-162-294-31	CERAMIC	0. 001uF	10%	50V	D301	8-719-987-63	DIODE	1N4148M (NEW TYPE)		
C804	1-162-294-31	CERAMIC	0. 001uF	10%	50V	D301	8-719-912-20	DIODE	1SS120 (FORMER TYPE)		
C805	1-162-294-31	CERAMIC	0. 001uF	10%	50V	D302	8-719-987-63	DIODE	1N4148M (NEW TYPE)		
C806	1-162-286-31	CERAMIC	220PF	10%	50V	D302	8-719-912-20	DIODE	1SS120 (FORMER TYPE)		
C807	1-162-294-31	CERAMIC	0. 001uF	10%	50V	D303	8-719-987-63	DIODE	1N4148M (NEW TYPE)		
C808	1-162-294-31	CERAMIC	0. 001uF	10%	50V	D303	8-719-912-20	DIODE	1SS120 (FORMER TYPE)		
C809	1-164-159-11	CERAMIC	0. 1uF		50V	D304	8-719-987-63	DIODE	1N4148M (NEW TYPE)		
C810	1-124-120-11	ELECT	220uF	20%	25V	D304	8-719-912-20	DIODE	1SS120 (FORMER TYPE)		
C851	1-161-379-00	CERAMIC	0. 01uF	20%	25V	D305	8-719-987-63	DIODE	1N4148M (NEW TYPE)		
C852	1-126-233-11	ELECT	22uF	20%	50V	D305	8-719-912-20	DIODE	1SS120 (FORMER TYPE)		
C853	1-161-494-00	CERAMIC	0. 022uF		25V	D307	8-719-987-63	DIODE	1N4148M (NEW TYPE)		
C854	1-164-159-11	CERAMIC	0. 1uF		50V	D307	8-719-912-20	DIODE	1SS120 (FORMER TYPE)		
C855	1-124-925-11	ELECT	2. 2uF	20%	100V	D308	8-719-987-63	DIODE	1N4148M (NEW TYPE)		
C861	1-124-927-11	ELECT	4. 7uF	20%	100V	D308	8-719-912-20	DIODE	1SS120 (FORMER TYPE)		
C862	1-124-477-11	ELECT	47uF	20%	25V						

AUDIO SYSCON

Ref. No.	Part No.	Description	Remark
D309	8-719-987-63	DIODE 1N4148M (NEW TYPE)	
D309	8-719-912-20	DIODE 1SS120 (FORMER TYPE)	
D505	8-719-987-63	DIODE 1N4148M (NEW TYPE)	
D505	8-719-912-20	DIODE 1SS120 (FORMER TYPE)	
D506	8-719-933-33	DIODE HZS6A1L	
D507	8-719-987-63	DIODE 1N4148M (NEW TYPE)	
D507	8-719-912-20	DIODE 1SS120 (FORMER TYPE)	
D508	8-719-987-63	DIODE 1N4148M (NEW TYPE)	
D508	8-719-912-20	DIODE 1SS120 (FORMER TYPE)	
D509	8-719-987-63	DIODE 1N4148M (NEW TYPE)	
D509	8-719-912-20	DIODE 1SS120 (FORMER TYPE)	
D801	8-719-987-63	DIODE 1N4148M (NEW TYPE)	
D801	8-719-912-20	DIODE 1SS120 (FORMER TYPE)	
D802	8-719-987-63	DIODE 1N4148M (NEW TYPE)	
D802	8-719-912-20	DIODE 1SS120 (FORMER TYPE)	
D851	8-719-987-63	DIODE 1N4148M (NEW TYPE)	
D851	8-719-912-20	DIODE 1SS120 (FORMER TYPE)	
D861	8-719-987-63	DIODE 1N4148M (NEW TYPE)	
D861	8-719-912-20	DIODE 1SS120 (FORMER TYPE)	
< IC >			
IC301	8-759-111-44	IC μ PC4570C-1	
IC302	8-752-059-55	IC CXA1331S (NEW TYPE)	
IC302	8-752-035-94	IC CXA1331S (FORMER TYPE)	
IC303	8-752-038-02	IC CXA1198AP	
IC304	8-759-634-51	IC M5218AP	
IC305	8-759-945-58	IC RC4558P	
IC306	8-759-945-58	IC RC4558P	
IC307	8-759-106-56	IC μ PC1297CA	
IC801	8-759-055-81	IC M50963-467SP (NEW TYPE)	
IC801	8-759-637-35	IC M50963-465SP (FORMER TYPE)	
IC871	8-759-973-95	IC BA6219B	
IC872	8-759-973-95	IC BA6219B	
IC881	8-759-973-95	IC BA6219B	
IC882	8-759-822-09	IC LB1641	
< COIL >			
L101	1-410-776-11	INDUCTOR 12mH	
L201	1-410-776-11	INDUCTOR 12mH	
< FILTER >			
LPF101	1-236-147-11	FILTER, LOW PASS	
LPF201	1-236-147-11	FILTER, LOW PASS	
< JACK >			
PJ301	1-565-258-11	JACK, PIN 4P (LINE IN/OUT)	

Ref. No.	Part No.	Description	Remark
< TRANSISTOR >			
Q101	8-729-900-74	TRANSISTOR DTC143TS	
Q102	8-729-900-80	TRANSISTOR DTC114ES	
Q103	8-729-900-74	TRANSISTOR DTC143TS	
Q104	8-729-922-37	TRANSISTOR 2SD2144S	
Q105	8-729-900-80	TRANSISTOR DTC114ES	
Q201	8-729-900-74	TRANSISTOR DTC143TS	
Q202	8-729-900-80	TRANSISTOR DTC114ES	
Q203	8-729-900-74	TRANSISTOR DTC143TS	
Q204	8-729-922-37	TRANSISTOR 2SD2144S	
Q205	8-729-900-80	TRANSISTOR DTC114ES	
Q301	8-729-821-04	TRANSISTOR 2SA1317-STU	
Q302	8-729-900-80	TRANSISTOR DTC114ES	
Q303	8-729-900-61	TRANSISTOR DTA114ES	
Q304	8-729-900-61	TRANSISTOR DTA114ES	
Q305	8-729-900-80	TRANSISTOR DTC114ES	
Q306	8-729-142-46	TRANSISTOR 2SC2001-LK	
Q307	8-729-142-46	TRANSISTOR 2SC2001-LK	
Q308	8-729-900-61	TRANSISTOR DTA114ES	
Q309	8-729-620-05	TRANSISTOR 2SC2603-EF	
Q310	8-729-900-61	TRANSISTOR DTA114ES	
Q311	8-729-900-80	TRANSISTOR DTC114ES	
Q313	8-729-900-61	TRANSISTOR DTA114ES	
Q314	8-729-900-80	TRANSISTOR DTC114ES	
Q315	8-729-900-80	TRANSISTOR DTC114ES	
Q316	8-729-900-80	TRANSISTOR DTC114ES	
Q317	8-729-620-05	TRANSISTOR 2SC2603-EF	
Q318	8-729-900-61	TRANSISTOR DTA114ES	
Q319	8-729-821-04	TRANSISTOR 2SA1317-STU	
Q322	8-729-900-80	TRANSISTOR DTC114ES	
Q323	8-729-900-80	TRANSISTOR DTC114ES	
Q501	8-729-209-15	TRANSISTOR 2SD2012	
Q502	8-729-141-83	TRANSISTOR 2SB1094-LK (NEW TYPE)	
Q502	8-729-111-67	TRANSISTOR 2SA473 (FORMER TYPE)	
Q503	8-729-620-05	TRANSISTOR 2SC2603-EF	
Q504	8-729-821-04	TRANSISTOR 2SA1317-STU	
Q505	8-729-821-04	TRANSISTOR 2SA1317-STU	
Q506	8-729-620-05	TRANSISTOR 2SC2603-EF	
Q507	8-729-821-04	TRANSISTOR 2SA1317-STU	
Q851	8-729-620-05	TRANSISTOR 2SC2603-EF	
Q852	8-729-620-05	TRANSISTOR 2SC2603-EF	
Q853	8-729-821-04	TRANSISTOR 2SA1317-STU	
Q861	8-729-620-05	TRANSISTOR 2SC2603-EF	
Q862	8-729-620-05	TRANSISTOR 2SC2603-EF	
Q883	8-729-900-80	TRANSISTOR DTC114ES	
Q884	8-729-900-80	TRANSISTOR DTC114ES	
Q885	8-729-900-80	TRANSISTOR DTC114ES	

AUDIO SYSCON

Ref. No.	Part No.	Description	Remark		
< RESISTOR >					
R101	1-249-428-11	CARBON	8. 2K	5%	1/4W
R102	1-249-435-11	CARBON	33K	5%	1/4W
R103	1-249-403-11	CARBON	68	5%	1/4W
R104	1-247-882-11	CARBON	130K	5%	1/4W
R105	1-249-426-11	CARBON	5. 6K	5%	1/4W
R106	1-249-421-11	CARBON	2. 2K	5%	1/4W
R107	1-247-840-00	CARBON	2. 4K	5%	1/4W
R108	1-247-887-00	CARBON	220K	5%	1/4W
R109	1-249-441-11	CARBON	100K	5%	1/4W
R110	1-249-423-11	CARBON	3. 3K	5%	1/4W
R111	1-249-428-11	CARBON	8. 2K	5%	1/4W
R112	1-247-864-11	CARBON	24K	5%	1/4W
R113	1-249-414-11	CARBON	560	5%	1/4W
R116	1-249-421-11	CARBON	2. 2K	5%	1/4W
R117	1-249-429-11	CARBON	10K	5%	1/4W
R118	1-249-427-11	CARBON	6. 8K	5%	1/4W
R120	1-249-425-11	CARBON	4. 7K	5%	1/4W
R121	1-249-425-11	CARBON	4. 7K	5%	1/4W
R123	1-249-433-11	CARBON	22K	5%	1/4W
R124	1-249-417-11	CARBON	1K	5%	1/4W
R125	1-249-421-11	CARBON	2. 2K	5%	1/4W
R126	1-249-431-11	CARBON	15K	5%	1/4W
R127	1-249-433-11	CARBON	22K	5%	1/4W
R128	1-249-409-11	CARBON	220	5%	1/4W
R129	1-249-421-11	CARBON	2. 2K	5%	1/4W
R130	1-249-408-11	CARBON	180	5%	1/4W
R131	1-249-436-11	CARBON	39K	5%	1/4W
R132	1-249-429-11	CARBON	10K	5%	1/4W
R134	1-249-435-11	CARBON	33K	5%	1/4W
R135	1-249-437-11	CARBON	47K	5%	1/4W
R136	1-249-435-11	CARBON	33K	5%	1/4W
R137	1-249-429-11	CARBON	10K	5%	1/4W
R138	1-249-432-11	CARBON	18K	5%	1/4W
R141	1-249-434-11	CARBON	27K	5%	1/4W
R142	1-249-432-11	CARBON	18K	5%	1/4W
△R143	1-212-857-00	FUSIBLE	10	5%	1/4W F
R144	1-247-883-00	CARBON	150K	5%	1/4W
R201	1-249-428-11	CARBON	8. 2K	5%	1/4W
R202	1-249-435-11	CARBON	33K	5%	1/4W
R203	1-249-403-11	CARBON	68	5%	1/4W
R204	1-247-882-11	CARBON	130K	5%	1/4W
R205	1-249-426-11	CARBON	5. 6K	5%	1/4W
R206	1-249-421-11	CARBON	2. 2K	5%	1/4W
R207	1-247-840-00	CARBON	2. 4K	5%	1/4W
R208	1-247-887-00	CARBON	220K	5%	1/4W
R209	1-249-441-11	CARBON	100K	5%	1/4W
R210	1-249-423-11	CARBON	3. 3K	5%	1/4W

Ref. No.	Part No.	Description	Remark		
R211	1-249-428-11	CARBON	8. 2K	5%	1/4W
R212	1-247-864-11	CARBON	24K	5%	1/4W
R213	1-249-414-11	CARBON	560	5%	1/4W
R216	1-249-421-11	CARBON	2. 2K	5%	1/4W
R217	1-249-429-11	CARBON	10K	5%	1/4W
R218	1-249-427-11	CARBON	6. 8K	5%	1/4W
R220	1-249-425-11	CARBON	4. 7K	5%	1/4W
R221	1-249-425-11	CARBON	4. 7K	5%	1/4W
R223	1-249-433-11	CARBON	22K	5%	1/4W
R224	1-249-417-11	CARBON	1K	5%	1/4W
R225	1-249-421-11	CARBON	2. 2K	5%	1/4W
R226	1-249-431-11	CARBON	15K	5%	1/4W
R227	1-249-433-11	CARBON	22K	5%	1/4W
R228	1-249-409-11	CARBON	220	5%	1/4W
R229	1-249-421-11	CARBON	2. 2K	5%	1/4W
R230	1-249-408-11	CARBON	180	5%	1/4W
R231	1-249-436-11	CARBON	39K	5%	1/4W
R232	1-249-429-11	CARBON	10K	5%	1/4W
R234	1-249-435-11	CARBON	33K	5%	1/4W
R235	1-249-437-11	CARBON	47K	5%	1/4W
R236	1-249-435-11	CARBON	33K	5%	1/4W
R237	1-249-429-11	CARBON	10K	5%	1/4W
R238	1-249-432-11	CARBON	18K	5%	1/4W
R241	1-249-434-11	CARBON	27K	5%	1/4W
R242	1-249-432-11	CARBON	18K	5%	1/4W
△R243	1-212-857-00	FUSIBLE	10	5%	1/4W F
R244	1-247-883-00	CARBON	150K	5%	1/4W
R301	1-249-429-11	CARBON	10K	5%	1/4W
R302	1-249-405-11	CARBON	100	5%	1/4W
R303	1-249-405-11	CARBON	100	5%	1/4W
R304	1-249-405-11	CARBON	100	5%	1/4W
R305	1-249-405-11	CARBON	100	5%	1/4W
R308	1-249-405-11	CARBON	100	5%	1/4W
R309	1-249-405-11	CARBON	100	5%	1/4W
R310	1-249-429-11	CARBON	10K	5%	1/4W
R311	1-249-430-11	CARBON	12K	5%	1/4W
R312	1-247-854-11	CARBON	9. 1K	5%	1/4W
R313	1-247-864-11	CARBON	24K	5%	1/4W
R314	1-249-441-11	CARBON	100K	5%	1/4W
R317	1-249-393-11	CARBON	10	5%	1/4W
R318	1-249-435-11	CARBON	33K	5%	1/4W
R319	1-249-435-11	CARBON	33K	5%	1/4W
R320	1-249-390-11	CARBON	5. 6	5%	1/6W
R321	1-249-390-11	CARBON	5. 6	5%	1/6W
R322	1-249-417-11	CARBON	1K	5%	1/4W
R323	1-249-421-11	CARBON	2. 2K	5%	1/4W
R324	1-249-431-11	CARBON	15K	5%	1/4W
R325	1-249-403-11	CARBON	68	5%	1/4W
R326	1-249-429-11	CARBON	10K	5%	1/4W

The components identified by mark △ or dotted line with mark △ are critical for safety. Replace only with part number specified.

Les composants identifiés par une marque △ sont critiques pour la sécurité. Ne les remplacer que par une pièce portant le numéro spécifié.

AUDIO SYSCON

Ref. No.	Part No.	Description	Remark			Ref. No.	Part No.	Description	Remark		
R327	1-215-455-00	METAL	27K	1%	1/6W	R801	1-249-405-11	CARBON	100	5%	1/4W
R328	1-249-417-11	CARBON	1K	5%	1/4W	R802	1-249-405-11	CARBON	100	5%	1/4W
R329	1-249-417-11	CARBON	1K	5%	1/4W	R803	1-249-405-11	CARBON	100	5%	1/4W
R330	1-249-441-11	CARBON	100K	5%	1/4W	R804	1-249-405-11	CARBON	100	5%	1/4W
R331	1-247-864-11	CARBON	24K	5%	1/4W	R805	1-249-405-11	CARBON	100	5%	1/4W
R332	1-249-433-11	CARBON	22K	5%	1/4W	R806	1-249-405-11	CARBON	100	5%	1/4W
R333	1-247-870-11	CARBON	43K	5%	1/4W	R807	1-249-405-11	CARBON	100	5%	1/4W
R334	1-247-868-11	CARBON	36K	5%	1/4W	R808	1-249-405-11	CARBON	100	5%	1/4W
R335	1-247-878-00	CARBON	91K	5%	1/4W	R809	1-249-433-11	CARBON	22K	5%	1/4W
R336	1-247-884-11	CARBON	160K	5%	1/4W	R810	1-249-433-11	CARBON	22K	5%	1/4W
R337	1-249-437-11	CARBON	47K	5%	1/4W	R811	1-249-433-11	CARBON	22K	5%	1/4W
R338	1-247-886-11	CARBON	200K	5%	1/4W	R812	1-249-433-11	CARBON	22K	5%	1/4W
R339	1-247-866-11	CARBON	30K	5%	1/4W	R813	1-249-425-11	CARBON	4.7K	5%	1/4W
R340	1-249-434-11	CARBON	27K	5%	1/4W	R814	1-249-429-11	CARBON	10K	5%	1/4W
R341	1-247-872-11	CARBON	51K	5%	1/4W	R815	1-249-429-11	CARBON	10K	5%	1/4W
R342	1-247-882-11	CARBON	130K	5%	1/4W	R816	1-249-425-11	CARBON	4.7K	5%	1/4W
R343	1-247-874-11	CARBON	62K	5%	1/4W	R821	1-249-425-11	CARBON	4.7K	5%	1/4W
R344	1-249-439-11	CARBON	68K	5%	1/4W	R822	1-249-425-11	CARBON	4.7K	5%	1/4W
R345	1-247-870-11	CARBON	43K	5%	1/4W	R823	1-249-425-11	CARBON	4.7K	5%	1/4W
R346	1-247-868-11	CARBON	36K	5%	1/4W	R824	1-249-425-11	CARBON	4.7K	5%	1/4W
R347	1-249-435-11	CARBON	33K	5%	1/4W	R825	1-249-436-11	CARBON	39K	5%	1/4W
R348	1-247-878-00	CARBON	91K	5%	1/4W	R826	1-249-436-11	CARBON	39K	5%	1/4W
R349	1-249-438-11	CARBON	56K	5%	1/4W	R827	1-249-409-11	CARBON	220	5%	1/4W
R350	1-249-438-11	CARBON	56K	5%	1/4W	R830	1-249-433-11	CARBON	22K	5%	1/4W
R351	1-249-409-11	CARBON	220	5%	1/4W	R831	1-249-425-11	CARBON	4.7K	5%	1/4W
R352	1-249-441-11	CARBON	100K	5%	1/4W	R832	1-249-425-11	CARBON	4.7K	5%	1/4W
R353	1-249-423-11	CARBON	3.3K	5%	1/4W	R833	1-249-425-11	CARBON	4.7K	5%	1/4W
R354	1-249-421-11	CARBON	2.2K	5%	1/4W	R834	1-249-421-11	CARBON	2.2K	5%	1/4W
R355	1-249-441-11	CARBON	100K	5%	1/4W	R835	1-249-433-11	CARBON	22K	5%	1/4W
R356	1-247-887-00	CARBON	220K	5%	1/4W	R836	1-249-417-11	CARBON	1K	5%	1/4W
R357	1-249-428-11	CARBON	8.2K	5%	1/4W	R837	1-249-417-11	CARBON	1K	5%	1/4W
R358	1-249-429-11	CARBON	10K	5%	1/4W	R838	1-249-429-11	CARBON	10K	5%	1/4W
R362	1-249-433-11	CARBON	22K	5%	1/4W	R839	1-249-429-11	CARBON	10K	5%	1/4W
R363	1-249-405-11	CARBON	100	5%	1/4W	R840	1-247-903-00	CARBON	1M	5%	1/4W
R364	1-249-429-11	CARBON	10K	5%	1/4W	R851	1-249-425-11	CARBON	4.7K	5%	1/4W
R365	1-249-405-11	CARBON	100	5%	1/4W	R852	1-249-433-11	CARBON	22K	5%	1/4W
R366	1-249-405-11	CARBON	100	5%	1/4W	R853	1-249-433-11	CARBON	22K	5%	1/4W
R501	1-249-433-11	CARBON	22K	5%	1/4W	R854	1-249-424-11	CARBON	3.9K	5%	1/4W
R502	1-249-421-11	CARBON	2.2K	5%	1/4W	R855	1-249-425-11	CARBON	4.7K	5%	1/4W
R503	1-249-421-11	CARBON	2.2K	5%	1/4W	R856	1-249-417-11	CARBON	1K	5%	1/4W
R504	1-249-421-11	CARBON	2.2K	5%	1/4W	R857	1-249-437-11	CARBON	47K	5%	1/4W
R505	1-249-421-11	CARBON	2.2K	5%	1/4W	R858	1-249-441-11	CARBON	100K	5%	1/4W
R506	1-249-417-11	CARBON	1K	5%	1/4W	R859	1-249-429-11	CARBON	10K	5%	1/4W
R507	1-249-417-11	CARBON	1K	5%	1/4W	R861	1-249-421-11	CARBON	2.2K	5%	1/4W
R508	1-249-417-11	CARBON	1K	5%	1/4W	R862	1-249-429-11	CARBON	10K	5%	1/4W
R509	1-249-415-11	CARBON	680	5%	1/4W	R863	1-249-433-11	CARBON	22K	5%	1/4W
R510	1-249-422-11	CARBON	2.7K	5%	1/4W	R864	1-249-429-11	CARBON	10K	5%	1/4W
R511	1-249-424-11	CARBON	3.9K	5%	1/4W	R865	1-249-429-11	CARBON	10K	5%	1/4W
R512	1-249-423-11	CARBON	3.3K	5%	1/4W	R866	1-249-417-11	CARBON	1K	5%	1/4W

AUDIO SYSCON MD

Ref. No.	Part No.	Description	Remark		
R867	1-247-826-00	CARBON	620	5%	1/4W
R871	1-249-414-11	CARBON	560	5%	1/4W
R872	1-249-417-11	CARBON	1K	5%	1/4W
R873	1-249-482-11	CARBON	4.7	5%	1/2W
R874	1-249-415-11	CARBON (NEW TYPE)	680	5%	1/4W
R874	1-247-822-11	CARBON (FORMER TYPE)	430	5%	1/4W
R875	1-249-417-11	CARBON	1K	5%	1/4W
R876	1-249-482-11	CARBON	4.7	5%	1/2W
△R877	1-212-942-00	FUSIBLE	2.2	5%	1/2W F
R880	1-249-413-11	CARBON (NEW TYPE)	470	5%	1/4W
R880	1-249-411-11	CARBON (FORMER TYPE)	330	5%	1/4W
R881	1-247-830-11	CARBON	910	5%	1/4W
R882	1-249-418-11	CARBON	1.2K	5%	1/4W
R883	1-249-417-11	CARBON	1K	5%	1/4W
R884	1-249-482-11	CARBON	4.7	5%	1/2W
R885	1-249-416-11	CARBON (NEW TYPE)	820	5%	1/4W
R885	1-249-421-11	CARBON (FORMER TYPE)	2.2K	5%	1/4W
R886	1-249-419-11	CARBON	1.5K	5%	1/4W
R887	1-249-417-11	CARBON	1K	5%	1/4W
R888	1-249-482-11	CARBON	4.7	5%	1/2W
R889	1-249-429-11	CARBON	10K	5%	1/4W
< VARIABLE RESISTOR >					
RV101	1-241-632-11	RES, ADJ, CARBON 47K (NEW TYPE)			
RV101	1-238-019-11	RES, ADJ, CARBON 47K (FORMER TYPE)			
RV102	1-241-630-11	RES, ADJ, CARBON 10K (NEW TYPE)			
RV102	1-238-016-11	RES, ADJ, CARBON 10K (FORMER TYPE)			
RV103	1-241-630-11	RES, ADJ, CARBON 10K (NEW TYPE)			
RV103	1-238-016-11	RES, ADJ, CARBON 10K (FORMER TYPE)			
RV201	1-241-632-11	RES, ADJ, CARBON 47K (NEW TYPE)			
RV201	1-238-019-11	RES, ADJ, CARBON 47K (FORMER TYPE)			
RV202	1-241-630-11	RES, ADJ, CARBON 10K (NEW TYPE)			
RV202	1-238-016-11	RES, ADJ, CARBON 10K (FORMER TYPE)			
RV203	1-241-630-11	RES, ADJ, CARBON 10K (NEW TYPE)			
RV203	1-238-016-11	RES, ADJ, CARBON 10K (FORMER TYPE)			
RV861	1-241-632-11	RES, ADJ, CARBON 47K (NEW TYPE)			
RV861	1-238-019-11	RES, ADJ, CARBON 47K (FORMER TYPE)			
RV881	1-241-630-11	RES, ADJ, CARBON 10K (NEW TYPE)			
RV881	1-238-016-11	RES, ADJ, CARBON 10K (FORMER TYPE)			

Ref. No.	Part No.	Description	Remark		
		< RELAY >			
RY301	1-515-683-11	RELAY			
		< TRANSFORMER >			
T141	1-433-335-11	TRANSFORMER, BIAS OSCILLATION			
T241	1-433-335-11	TRANSFORMER, BIAS OSCILLATION			
T301	1-433-336-11	TRANSFORMER, BIAS OSCILLATION			
		< TEST PIN >			
* TP341	1-568-449-11	HOUSING, CONNECTOR(PC BOARD)3P			
* TP801	1-564-506-11	PLUG, CONNECTOR 3P			
* TP802	1-564-506-11	PLUG, CONNECTOR 3P			
* TP861	1-564-505-11	PLUG, CONNECTOR 2P			
		< VIBRATOR >			
X801	1-577-358-21	VIBRATOR, CERAMIC 4MHz			

*	1-632-740-11	MD BOARD			

	3-356-631-01	HOLDER (SENSOR)			
		< CONNECTOR >			
CN1001	1-506-615-11	PIN, CONNECTOR 9P			
* CN1002	1-564-502-11	PIN, CONNECTOR 10P			
		< IC >			
IC1001	8-749-920-97	PHOTOSENSOR	GP2S22B		
IC1002	8-749-920-97	PHOTOSENSOR	GP2S22B		
		< RESISTOR >			
R1001	1-249-407-11	CARBON	150	5%	1/4W
R1002	1-249-407-11	CARBON	150	5%	1/4W
		< SWITCH >			
S1003	1-571-958-11	SWITCH, PUSH (1 KEY) (CLOSE)			
S1004	1-572-126-11	SWITCH, PUSH (1 KEY) (OPEN)			
S1005	1-572-125-11	SWITCH, LEAF (FWD TAB)			
S1006	1-572-202-11	SWITCH, LEAF (HALF)			
S1007	1-572-125-11	SWITCH, LEAF (METAL)			
S1008	1-572-125-11	SWITCH, LEAF (70uS)			
S1009	1-572-125-11	SWITCH, LEAF (REV TAB)			
		< TERMINAL >			
* TB1001	1-694-018-11	TERMINAL (5P) (NEW TYPE)			
* TB1001	1-569-066-11	PIN, CONNECTOR 5P (FORMER TYPE)			

The components identified by mark △ or dotted line with mark. △ are critical for safety. Replace only with part number specified.	Les composants identifiés par une marque △ sont critiques pour la sécurité. Ne les remplacer que par une pièce portant le numéro spécifié.
---	--

PANEL POWER

Ref. No.	Part No.	Description	Remark
*	A-2006-621-A	PANEL POWER BOARD, COMPLETE (including PANEL (L) BOARD, PANEL (R) BOARD, POWER SUPPLY BOARD, TRANS BOARD, H. P BOARD) *****	
*△	1-533-213-31	HOLDER, FUSE	
*	3-309-144-21	HEAT SINK	
*	3-350-145-01	HOLDER, FL TUBE	
*	4-921-941-01	CUSHION (FL) (NEW TYPE)	
	7-685-646-79	SCREW +BVTP 3X8 TYPE2	
	7-682-547-04	SCREW +BVTT 3X6 (S)	
< CAPACITOR >			
C334	1-164-159-11	CERAMIC 0.1uF	50V
C701	1-124-907-11	ELECT 10uF	20% 50V
C702	1-126-946-11	ELECT 6800uF	20% 25V
C703	1-124-477-11	ELECT 47uF	20% 25V
C704	1-124-898-11	ELECT 4700uF	20% 16V
C705	1-124-556-11	ELECT 2200uF	20% 16V
C706	1-124-443-00	ELECT 100uF	20% 10V
C707	1-124-471-00	ELECT 1000uF	20% 6.3V
C708	1-124-911-11	ELECT 220uF	20% 50V
C709	1-124-927-11	ELECT 4.7uF	20% 100V
C710	1-124-927-11	ELECT 4.7uF	20% 100V
C711	1-124-556-11	ELECT 2200uF	20% 16V
C712	1-124-556-11	ELECT 2200uF	20% 16V
C901	1-126-154-11	ELECT 47uF	20% 6.3V
C902	1-164-159-11	CERAMIC 0.1uF	50V
C903	1-161-494-00	CERAMIC 0.022uF	25V
C904	1-162-286-31	CERAMIC 220PF	10% 50V
C905	1-162-286-31	CERAMIC 220PF	10% 50V
C906	1-161-494-00	CERAMIC 0.022uF	25V
C907	1-126-163-11	ELECT 4.7uF	20% 50V
C908	1-164-159-11	CERAMIC 0.1uF	50V (NEW TYPE)
C991	1-126-163-11	ELECT 4.7uF	20% 50V
< CONNECTOR >			
CN306	1-564-507-11	PLUG, CONNECTOR 4P	
* CN308	1-568-824-11	SOCKET, CONNECTOR 5P	
* CN701	1-568-830-21	SOCKET, CONNECTOR 11P	
* CN702	1-568-830-21	SOCKET, CONNECTOR 11P	
* CN703	1-568-830-11	SOCKET, CONNECTOR 11P	
* CN705	1-508-882-00	BASE POST	
* CN802	1-568-824-11	SOCKET, CONNECTOR 5P	
* CN901	1-568-830-11	SOCKET, CONNECTOR 11P	
* CN902	1-568-830-11	SOCKET, CONNECTOR 11P	

Ref. No.	Part No.	Description	Remark
< DIODE >			
D701	8-719-200-77	DIODE 10E2N	
D702	8-719-500-36	DIODE D2S820	
D703	8-719-987-63	DIODE 1N4148M (NEW TYPE)	
D703	8-719-912-20	DIODE 1SS120 (FORMER TYPE)	
D704	8-719-001-54	DIODE UZL-11H2	
D705	8-719-200-77	DIODE 10E2N	
D706	8-719-933-41	DIODE HZS6C3L	
D707	8-719-987-63	DIODE 1N4148M (NEW TYPE)	
D707	8-719-912-20	DIODE 1SS120 (FORMER TYPE)	
D708	8-719-933-38	DIODE HZS6B3L	
D709	8-719-200-77	DIODE 10E2N	
D710	8-719-200-77	DIODE 10E2N	
D711	8-719-200-77	DIODE 10E2N	
D712	8-719-200-77	DIODE 10E2N	
D713	8-719-987-63	DIODE 1N4148M (NEW TYPE)	
D713	8-719-912-20	DIODE 1SS120 (FORMER TYPE)	
< FUSE >			
△F1	1-532-259-00	FUSE, TIME-LAG T1.6A 250V (AEP, G, UK, E)	
△F1	1-532-742-11	FUSE, GLASS TUBE 1.6A 125V (US, CND)	
△F2	1-532-259-00	FUSE, TIME-LAG T1.6A 250V (AEP, G, UK, E)	
△F2	1-532-742-11	FUSE, GLASS TUBE 1.6A 125V (US, CND)	
< FILTER >			
FL901	1-519-687-11	INDICATOR TUBE, FLUORESCENT	
< IC >			
IC901	8-759-637-33	IC M50940-340SP	
IC991	8-741-100-48	IC SBX1610-59	
< JACK >			
J501	1-507-981-11	JACK (LARGE TYPE) (HEADPHONES)	
< TRANSISTOR >			
Q701	8-729-620-05	TRANSISTOR 2SC2603-EF	
Q702	8-729-141-83	TRANSISTOR 2SB1094-LK (NEW TYPE)	
Q702	8-729-111-67	TRANSISTOR 2SA473 (FORMER TYPE)	
Q703	8-729-620-05	TRANSISTOR 2SC2603-EF	
Q704	8-729-620-05	TRANSISTOR 2SC2603-EF	
Q705	8-729-209-15	TRANSISTOR 2SD2012	
Q706	8-729-821-04	TRANSISTOR 2SA1317-STU	
Q707	8-729-140-04	TRANSISTOR 2SB1116A-L	
Q991	8-729-900-61	TRANSISTOR DTA114ES	
< RESISTOR >			
R359	1-249-413-11	CARBON 470 5% 1/4W	

The components identified by mark △ or dotted line with mark. △ are critical for safety. Replace only with part number specified.

Les composants identifiés par une marque △ sont critiques pour la sécurité. Ne les remplacer que par une pièce portant le numéro spécifié.

PANEL POWER

Ref. No.	Part No.	Description	Remark			Ref. No.	Part No.	Description	Remark		
R360	1-249-413-11	CARBON	470	5%	1/4W	R961	1-249-421-11	CARBON	2.2K	5%	1/4W
R701	1-249-433-11	CARBON	22K	5%	1/4W	R962	1-249-423-11	CARBON	3.3K	5%	1/4W
R702	1-249-419-11	CARBON	1.5K	5%	1/4W	R963	1-249-426-11	CARBON	5.6K	5%	1/4W
△R704	1-219-136-11	FUSIBLE	0.22	10%	1/4W	R964	1-247-856-00	CARBON	11K	5%	1/4W
R705	1-249-422-11	CARBON	2.7K	5%	1/4W	R971	1-249-421-11	CARBON	2.2K	5%	1/4W
R706	1-249-421-11	CARBON	2.2K	5%	1/4W	R981	1-249-421-11	CARBON	2.2K	5%	1/4W
R707	1-249-422-11	CARBON	2.7K	5%	1/4W	R991	1-249-429-11	CARBON	10K	5%	1/4W
R708	1-249-430-11	CARBON	12K	5%	1/4W			< VARIABLE RESISTOR >			
R709	1-249-429-11	CARBON	10K	5%	1/4W	RV301	1-241-524-11	RES, VAR, CARBON 50K/50K (REC LEVEL)			
R710	1-249-436-11	CARBON	39K	5%	1/4W	RV302	1-241-655-11	RES, VAR, CARBON 50K/50K (BALANCE)			
△R712	1-219-139-11	FUSIBLE	0.68	10%	1/4W			< SWITCH >			
△R713	1-219-139-11	FUSIBLE	0.68	10%	1/4W	S301	1-572-374-11	SWITCH, SLIDE (DOLBY NR)			
△R791	1-249-385-11	CARBON	2.2	5%	1/6W	S893	1-570-953-11	SWITCH, PUSH (1 KEY) (CASSETTE LID)			
R901	1-249-405-11	CARBON	100	5%	1/4W	S931	1-554-303-21	SWITCH, TACTILE (OPEN/CLOSE)			
R902	1-249-405-11	CARBON	100	5%	1/4W	S932	1-554-303-21	SWITCH, TACTILE (AMS REW)			
R903	1-249-405-11	CARBON	100	5%	1/4W	S933	1-554-303-21	SWITCH, TACTILE (AMS FF)			
R904	1-249-405-11	CARBON	100	5%	1/4W	S934	1-554-303-21	SWITCH, TACTILE (REC)			
R905	1-249-405-11	CARBON	100	5%	1/4W	S935	1-554-303-21	SWITCH, TACTILE (COUNTER RESET)			
R906	1-249-405-11	CARBON	100	5%	1/4W	S936	1-554-303-21	SWITCH, TACTILE (COUNTER MEMORY)			
R907	1-249-433-11	CARBON	22K	5%	1/4W	S941	1-554-303-21	SWITCH, TACTILE (STOP)			
R908	1-249-417-11	CARBON	1K	5%	1/4W	S942	1-554-303-21	SWITCH, TACTILE (PAUSE)			
R909	1-247-903-00	CARBON	1M	5%	1/4W	S943	1-554-303-21	SWITCH, TACTILE (FWD)			
R911	1-247-856-00	CARBON	11K	5%	1/4W	S944	1-554-303-21	SWITCH, TACTILE (REV)			
R912	1-247-856-00	CARBON	11K	5%	1/4W	S945	1-554-303-21	SWITCH, TACTILE (REC MUTE)			
R913	1-247-856-00	CARBON	11K	5%	1/4W	S951	1-554-303-21	SWITCH, TACTILE (SKIP)			
R914	1-247-856-00	CARBON	11K	5%	1/4W	S952	1-554-303-21	SWITCH, TACTILE (ALL REW)			
R915	1-247-856-00	CARBON	11K	5%	1/4W	S953	1-554-303-21	SWITCH, TACTILE (BLK SKIP)			
R916	1-247-856-00	CARBON	11K	5%	1/4W	S954	1-554-303-21	SWITCH, TACTILE (SYNC MODE)			
R917	1-249-421-11	CARBON	2.2K	5%	1/4W	S955	1-554-303-21	SWITCH, TACTILE (SHUFFLE)			
R918	1-249-421-11	CARBON	2.2K	5%	1/4W	S956	1-554-303-21	SWITCH, TACTILE (PROGRAM)			
R919	1-249-425-11	CARBON	4.7K	5%	1/4W	S961	1-554-303-21	SWITCH, TACTILE (1)			
R920	1-249-421-11	CARBON	2.2K	5%	1/4W	S962	1-554-303-21	SWITCH, TACTILE (2)			
R921	1-249-409-11	CARBON	220	5%	1/4W	S963	1-554-303-21	SWITCH, TACTILE (3)			
R922	1-249-409-11	CARBON	220	5%	1/4W	S964	1-554-303-21	SWITCH, TACTILE (4)			
R923	1-249-409-11	CARBON	220	5%	1/4W	S965	1-554-303-21	SWITCH, TACTILE (5)			
R931	1-249-421-11	CARBON	2.2K	5%	1/4W	S971	1-571-520-11	SWITCH, SLIDE (DIRECTION)			
R932	1-249-423-11	CARBON	3.3K	5%	1/4W	S981	1-571-520-11	SWITCH, SLIDE (TIMER)			
R933	1-249-426-11	CARBON	5.6K	5%	1/4W	S991	1-554-118-00	SWITCH, PUSH (1 KEY) (POWER)			
R934	1-247-856-00	CARBON	11K	5%	1/4W			< TRANSFORMER >			
R935	1-249-435-11	CARBON	33K	5%	1/4W	△T1	1-450-444-11	TRANSFORMER, POWER (US, CND)			
R941	1-249-421-11	CARBON	2.2K	5%	1/4W	△T1	1-450-445-11	TRANSFORMER, POWER (E)			
R942	1-249-423-11	CARBON	3.3K	5%	1/4W	△T1	1-450-446-11	TRANSFORMER, POWER (AEP, G, UK)			
R943	1-249-426-11	CARBON	5.6K	5%	1/4W			< THERMISTOR >			
R944	1-247-856-00	CARBON	11K	5%	1/4W	TH791	1-806-882-11	THERMISTOR, POSITIVE			
R951	1-249-421-11	CARBON	2.2K	5%	1/4W						
R952	1-249-423-11	CARBON	3.3K	5%	1/4W						
R953	1-249-426-11	CARBON	5.6K	5%	1/4W						
R954	1-247-856-00	CARBON	11K	5%	1/4W						
R955	1-249-435-11	CARBON	33K	5%	1/4W						

The components identified by mark △ or dotted line with mark. △ are critical for safety. Replace only with part number specified.

Les composants identifiés par une marque △ sont critiques pour la sécurité. Ne les remplacer que par une pièce portant le numéro spécifié.

PANEL POWER

REEL MOTOR

SLIDER

TRANSLATION

Ref. No.	Part No.	Description	Remark
		< VIBRATOR >	
X901	1-577-358-21	VIBRATOR, CERAMIC 4MHz	

*	1-632-741-11	REEL MOTOR BOARD	

		< CAPACITOR >	
C1051	1-124-907-11	ELECT 10uF 20% 50V	
C1052	1-124-907-11	ELECT 10uF 20% 50V	
C1053	1-164-159-11	CERAMIC 0.1uF 50V	
		< CONNECTOR >	
CN1051	1-564-501-11	PIN, CONNECTOR 8P	
* CN1052	1-564-720-11	PIN, CONNECTOR (SMALL TYPE) 4P	
* CN1053	1-564-718-11	PIN, CONNECTOR (SMALL TYPE) 2P	
		< MOTOR >	
M1051	X-3356-638-1	MOTOR (REEL R) ASSY	
M1052	X-3356-604-1	MOTOR (ASSIST) ASSY	
		< RESISTOR >	
R1051	1-249-414-11	CARBON 560 5% 1/4W	

*	1-641-110-11	SLIDER BOARD (including DRUM PULSE BOARD, DRUM TRAY MOTOR BOARD, DRUM CLK BOARD, IN/OUT SW BOARD)	

		< CAPACITOR >	
C891	1-124-768-11	ELECT 4.7uF 20% 50V	
C892	1-124-768-11	ELECT 4.7uF 20% 50V	
C893	1-164-159-11	CERAMIC 0.1uF 50V	
C894	1-164-159-11	CERAMIC 0.1uF 50V	
		< CONNECTOR >	
* CN894	1-568-830-11	SOCKET, CONNECTOR 11P	
* CN895	1-564-338-00	PIN, CONNECTOR 4P	
* CN896	1-564-337-00	PIN, CONNECTOR 3P	
* CN898	1-564-337-61	PIN, CONNECTOR 3P	
		< DIODE >	
D891	8-719-970-19	PHOTOINTERRUPTER GP-1A521	
D892	8-719-970-19	PHOTOINTERRUPTER GP-1A521	
		< MOTOR >	
M891	X-3363-669-1	MOTOR (TRAY) ASSY	
M892	X-3363-669-1	MOTOR (TRAY) ASSY (NEW TYPE)	

Ref. No.	Part No.	Description	Remark
M892	X-3363-670-1	MOTOR (DRUM) ASSY (FORMER TYPE)	
		< RESISTOR >	
R891	1-249-413-11	CARBON 470 5% 1/4W	
R892	1-249-413-11	CARBON 470 5% 1/4W	
		< SWITCH >	
S891	1-571-300-21	SWITCH, ROTARY (TRAY I/O)	

*	1-634-323-11	TRANSLATION BOARD	

		< CONNECTOR >	
* CN1091	1-564-709-11	PIN, CONNECTOR (SMALL TYPE) 7P	
* CN1092	1-564-509-11	PLUG, CONNECTOR 6P	
* CN1093	1-564-705-11	PIN, CONNECTOR (SMALL TYPE) 3P	
* CN1094	1-564-506-11	PLUG, CONNECTOR 3P	

		MISCELLANEOUS	

64	1-534-517-00	WIRE, FLAT TYPE (11 CORE)	
67	1-690-319-11	WIRE, FLAT TYPE (11 CORE)	
68	1-575-779-11	WIRE, FLAT TYPE (5 CORE)	
69	1-575-778-11	WIRE, FLAT TYPE (5 CORE)	
158	1-534-517-00	WIRE, FLAT TYPE (11 CORE)	
159	1-690-320-11	WIRE, FLAT TYPE (11 CORE)	
160	1-534-517-00	WIRE, FLAT TYPE (11 CORE)	
△162	1-551-188-XX	CORD, POWER (E)	
△162	1-555-465-00	CORD, POWER (C5/US, CND)	
△162	1-555-792-00	CORD, POWER, EULO PLUG (AEP, G)	
△162	1-556-035-00	CORD, POWER (UK)	
△162	1-590-836-31	CORD, POWER (C521)	
△172	1-569-007-11	ADAPTER, CONVERSION 2P (E)	
D1001	8-719-980-85	LED SLF325C (CASSETE)	
D1091	8-719-950-74	PHOTOINTERRUPTER SLR-314D	
HRPE	A-2003-722-A	DECK ASSY, HEAD (This parts, if ordered, contains the SENSOR board.)	
1001			
M1002	X-3365-002-1	MOTOR (CAPSTAN R30) ASSY	
Q1091	8-729-809-43	PHOTOINTERRUPTER SPS-314B	
S892	1-572-713-11	SWITCH, PUSH (WITH CONNECTOR) (MID)	
S1001	1-466-525-11	ENCODER, ROTARY	
△VS1	1-692-155-11	SELECTOR, POWER VOLTAGE (VOLTAGE) (E)	

The components identified by mark △ or dotted line with mark △ are critical for safety. Replace only with part number specified.

Les composants identifiés par une marque △ sont critiques pour la sécurité. Ne les remplacer que par une pièce portant le numéro spécifié.

Ref. No.	Part No.	Description	Remark
ACCESSORIES & PACKING MATERIALS			

	1-465-912-11	REMOTE COMMANDER (RM-J801) (EXCEPT FOR C521)	
	1-558-271-11	CORD, CONNECTION	
*	3-371-943-01	CUSHION	
*	3-371-944-01	INDIVIDUAL CARTON (EXCEPT FOR C521)	
	3-703-450-01	INSTRUCTION (C5/US) (FORMER TYPE)	
	3-754-020-11	MANUAL, INSTRUCTION (ENGLISH, FRENCH , SPANISH, PORTUGUESE (AEP, UK, E)	
	3-754-020-21	MANUAL, INSTRUCTION (ENGLISH) (C5/US, CND)	
	3-754-020-31	MANUAL, INSTRUCTION (FRENCH) (CND)	
	3-754-020-41	MANUAL, INSTRUCTION (GERMAN, DUTCH , SWEDISH, ITALIAN) (AEP)	
	3-754-020-51	MANUAL, INSTRUCTION (G) (FRENCH)	
	3-755-386-21	MANUAL, INSTRUCTION (ENGLISH) (C521)	

HARDWARE LIST

- #1 7-682-548-09 SCREW +BVTT 3X8 (S)
- #2 7-621-775-40 SCREW (2.6X8), STPWH (FORMER TYPE)
- #3 7-685-133-19 SCREW +BTP 2.6X6 TYPE2 N-S
- #4 7-621-770-67 SCREW +BVTT 2.6X6 (S)
- #5 7-627-854-07 PRECISION SCREW +P 2X2.5 TYPE3

- #6 7-623-421-07 LW 2.6, TYPE B (FORMER TYPE)
- #7 7-621-775-00 SCREW +B 2.6X3
- #8 7-621-775-68 SCREW +BVTT 2.6X12 (S)
- #9 7-682-547-09 SCREW +BVTT 3X6 (S)
- #10 7-682-547-04 SCREW +BVTT 3X6 (S)

- #11 7-621-849-00 SCREW (BV/RING)
- #12 7-621-773-93 SCREW (PANEL 2.6 TP2)
- #13 7-687-233-11 SCREW (+ PTPWH) (2.6X6)
- #14 7-685-646-79 SCREW +BVTP 3X8 TYPE2 N-S
- #15 7-685-870-09 SCREW +BVTT 3X5 (S)

- #16 7-621-773-95 SCREW +BVTT 2.6X6 (S) (FORMER TYPE)
- #17 7-621-255-35 SCREW +BVTT 2X5 (S)
- #18 7-685-131-19 SCREW +BTP 2.6X4 TYPE2 N-S

TC-C5/C521

SONY SERVICE MANUAL

US Model

TC-C5/C521

Canadian Model

AEP Model

UK Model

E model

TC-C5

CORRECTION-1

Correct your service manual as shown below.

____ (Under line) : indicates corrected portion.

Page	INCORRECT			CORRECT		
	<u>Ref. No.</u>	<u>Part No.</u>	<u>Description</u>	<u>Ref. No.</u>	<u>Part No.</u>	<u>Description</u>
42	64	1-534-517-00	WIRE, FLAT TYPE (11 CORE)	64	<u>1-590-575-11</u>	WIRE, FLAT TYPE (11 CORE)
44	158	1-534-517-00	WIRE, FLAT TYPE (11 CORE)	158	<u>1-590-575-11</u>	WIRE, FLAT TYPE (11 CORE)
	160	1-534-517-00	WIRE, FLAT TYPE (11 CORE)	160	<u>1-590-575-11</u>	WIRE, FLAT TYPE (11 CORE)
55	64	1-534-517-00	WIRE, FLAT TYPE (11 CORE)	64	<u>1-590-575-11</u>	WIRE, FLAT TYPE (11 CORE)
	158	1-534-517-00	WIRE, FLAT TYPE (11 CORE)	158	<u>1-590-575-11</u>	WIRE, FLAT TYPE (11 CORE)
	160	1-534-517-00	WIRE, FLAT TYPE (11 CORE)	160	<u>1-590-575-11</u>	WIRE, FLAT TYPE (11 CORE)

(SPM-96017)