

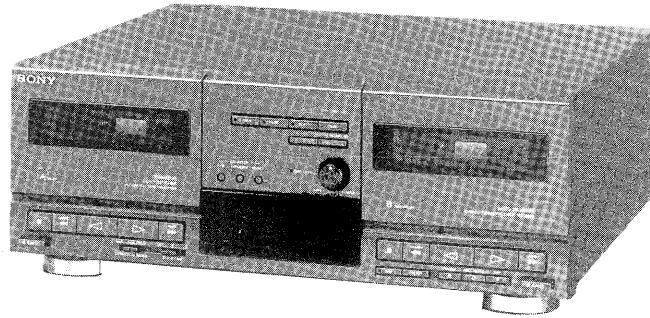

TC-D607

SERVICE MANUAL

*AEP Model
UK Model
E Model
Australian Model*



• This set is the cassette deck section in LBT-D607/D607CD.

Dolby noise reduction manufactured under license from Dolby Laboratories Licensing Corporation. "DOLBY" and the double-D symbol  are trademarks of Dolby Laboratories Licensing Corporation.

Model Name Using Similar Mechanism	TC-H1600
Tape Transport Mechanism Type	DECK A : TCM-190RA12C DECK B : TCM-190RB22C

SPECIFICATIONS

Recording system	4-track 2-channel stereo
Frequency response	DOLBY NR OFF With Type IV cassette (Sony METAL-ES) 30 Hz to 15 kHz (± 3 dB) With Type II cassette (Sony UX-S) 40 Hz to 14 kHz (± 3 dB) With Type I cassette (Sony HF-S) 40 Hz to 14 kHz (± 3 dB)
Wow and flutter	$\pm 0.2\%$ (DIN)
Weight	Approx. 3.5 kg (8 lbs 1 oz)
Dimensions	Approx. 355 x 131 x 304 mm (14 x 5 $\frac{1}{4}$ x 12 inches) (w/h/d, including projections)

Design and specifications are subject to change without notice.

Note

This appliance conforms with EEC Directive 87/308/EEC regarding interference suppression.



STEREO CASSETTE DECK
SONY®

TABLE OF CONTENTS

<u>Section</u>	<u>Title</u>	<u>Page</u>
SECTION 1.	GENERAL	3
SECTION 2.	DISASSEMBLY	4
SECTION 3.	MECHANICAL ADJUSTMENTS	6
SECTION 4.	ELECTRICAL ADJUSTMENTS	6
SECTION 5.	DIAGRAMS	
5-1.	Circuit Boards Location	10
5-2.	Semiconductor Lead Layouts	11
5-3.	Printed Wiring Boards — Main Section —	12
5-4.	Schematic Diagrams — Main Section —	17
5-5.	Printed Wiring Boards — Panel Section —	21
5-6.	Schematic Diagrams — Panel Section —	23
SECTION 6.	EXPLODED VIEWS	
6-1.	Overall Section	25
6-2.	Front Panel Section	26
6-3.	Mechanism-1 Section	27
6-4.	Mechanism-2 Section	28
SECTION 7.	ELECTRICAL PARTS LIST	29

SECTION 1 GENERAL

This section is extracted
from instruction manual.

Location of Controls

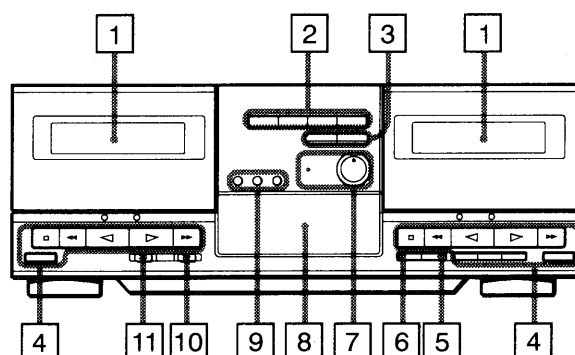

- 1 Cassette holders
- 2 AUTO CD SYNCHRO REC buttons and indicators
C.(Cross) FADE (29)
FADE (28)
EDIT (31)
TIME (31)
- 3 SYNCHRO DUBBING buttons (24)
- 4 Tape operation buttons
◀◀ Leftward fast winding/AMS*, ▶▶ Rightward fast winding/AMS*, ▶ Forward play, ◀ Reverse play, ■ Stop, ▲ EJECT, || PAUSE(deck B only), ○ REC MUTE Record muting (deck B only), ● REC Record (deck B only)
- 5 FADER button (22)
- 6 ARL (Automatic recording level) button and indicator (21)
- 7 REC (recording) LEVEL control and indicator (20)
- 8 Display window
- 9 COUNTER setting buttons (19)
A/B, MEMORY and RESET button
- 10 DOLBY NR (noise reduction) selector (20)
- 11 DIRECTION MODE selector (17, 20, 24)

* AMS is the abbreviation of Automatic Music Sensor.

SECTION 2 DISASSEMBLY

NOTE: Follow the disassembly procedure in the numerical order given.

CASE
Unscrew the four case attachment screws M3×8 and remove the case.

FRONT PANEL

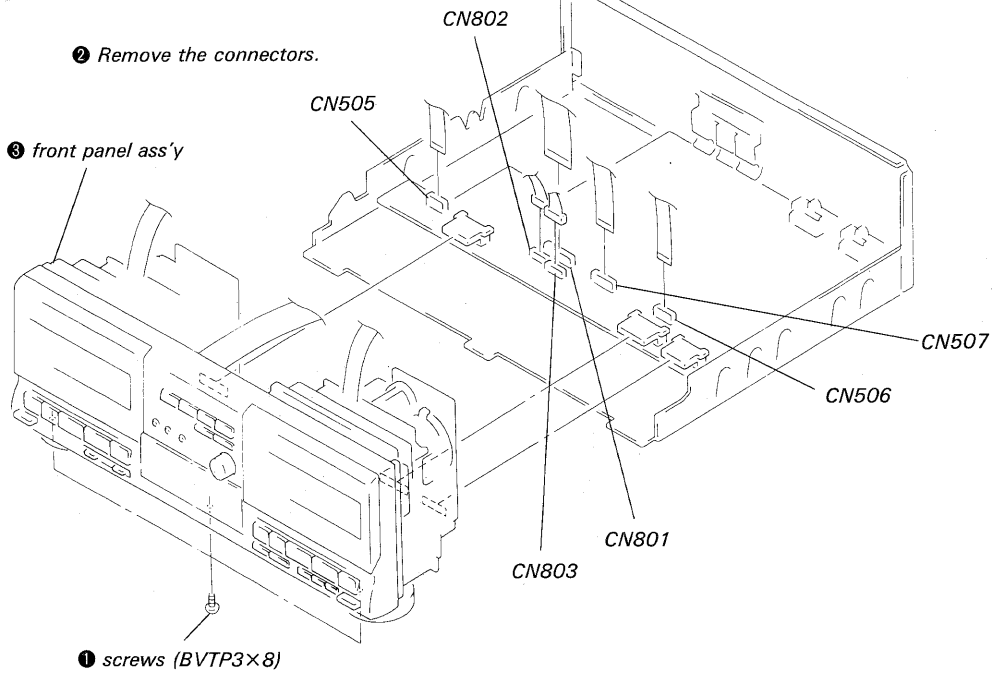

MECHANISM DECK

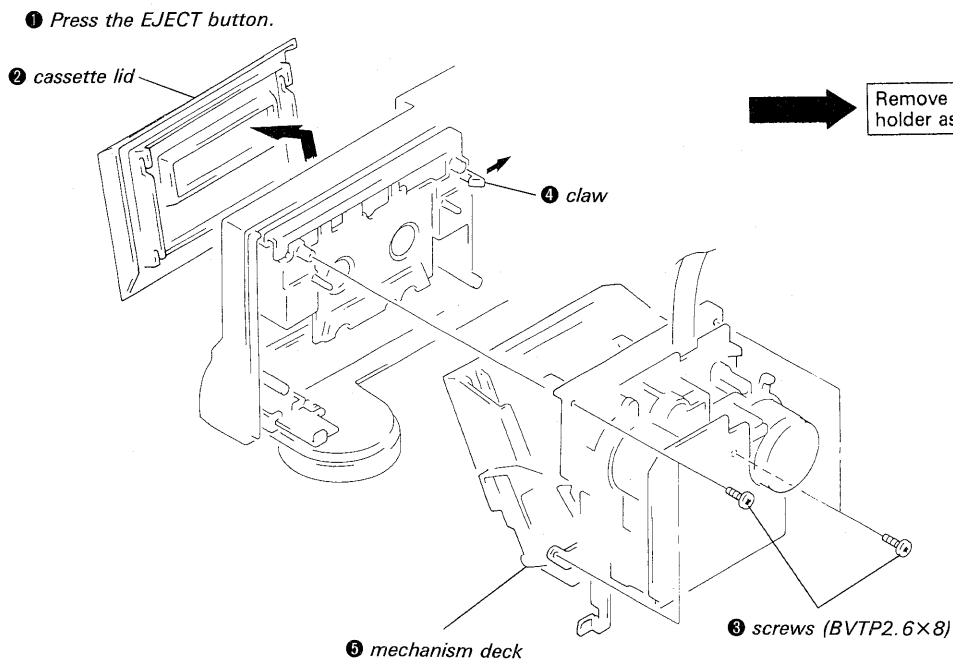

Remove the cassette holder assembly.

HEAD

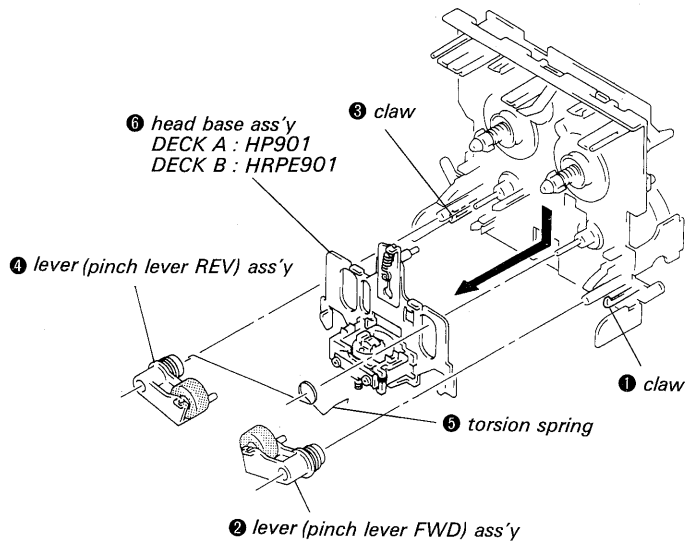

MOTOR

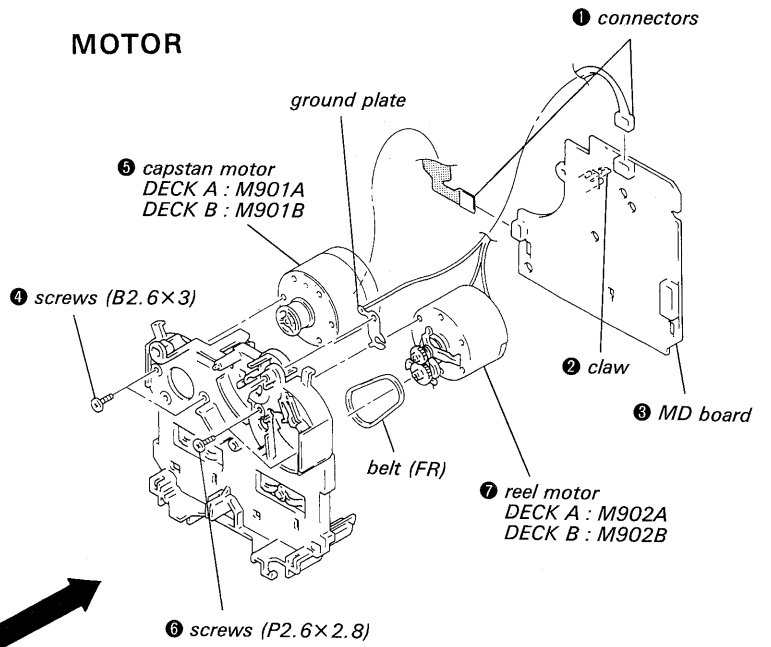

FITTING BASE BLOCK

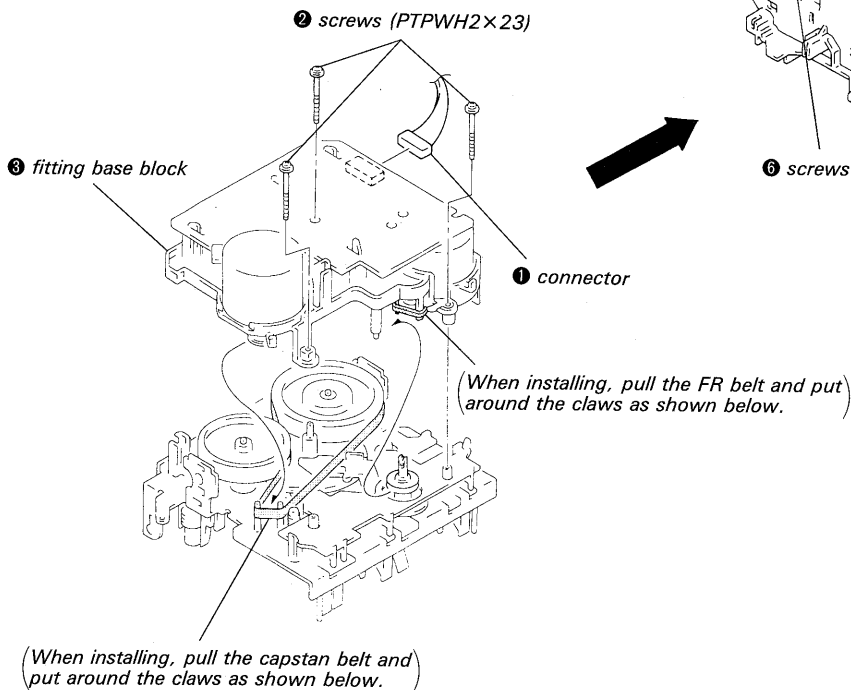

SECTION 3 MECHANICAL ADJUSTMENTS

PRECAUTION

1. Clean the following parts with a denatured-alcoholmois-tened swab;
 - record/playback/erase head
 - pinch roller rubber belts
 - capstan idler
2. Demagnetize the record/playback head with a head demagnetizer.
(Head demagnetizer do not approach for the erase head.)
3. Do not use a magnetized screwdriver for the adjustments.
4. After the adjustments, apply suitable locking compound to the parts adjusted.
5. The adjustments should be performed in the rated power supply voltage unless otherwise noted.

Torque Measurement

Torque	Torque meter	Meter reading
FWD	CQ-102C	35 to 60g · cm (0.49 to 0.83 oz · inch)
FWD Back tension	CQ-102C	2 to 6g · cm (0.03 to 0.08 oz · inch)
REV	CQ-102RC	35 to 60g · cm (0.49 to 0.83 oz · inch)
REV Back tension	CQ-102RC	2 to 6g · cm (0.03 to 0.08 oz · inch)
FF, REW	CQ-201B	70 to 110g · cm (0.98 to 1.52 oz · inch)

SECTION 4 ELECTRICAL ADJUSTMENTS

Note: The adjustment should be performed in the order given in the service manual. As a rule, adjustment about playback should be performed before adjustment about recording. The adjustments should be performed for both L-CH and R-CH.

● **Test Mode**

The Test mode is activated by shorting Test Point Service mode (IC805 34 pin changes over to "L") with the POWER switch in OFF position, then turning on the POWER switch.

In this mode, the following functions operate:

1. Source monitor
Line mute is cancelled during recording.
2. High speed playback
High speed playback is executed when the HIGH SPEED (DUBBING) button is jpressed during playback. Normal speed playback is restored when the button is pressed again.
3. Record memory
The tape counter is reset to "0" at the record start point. After adjustment, open the Service mode to cancel the Test mode.

[MAIN BOARD] (CONDUCTOR SIDE)

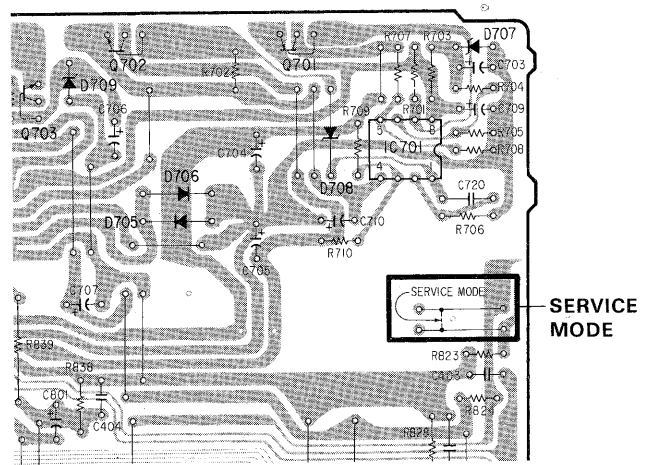

- Switches and controls should be set as follows unless otherwise specified.

NR switch : OFF
DIR MODE switch : ↔

- Standard Record:
Deliver the standard input signal level to the input jack and set the REC LEVEL control to obtain the standard output signal level.

– Record Mode –

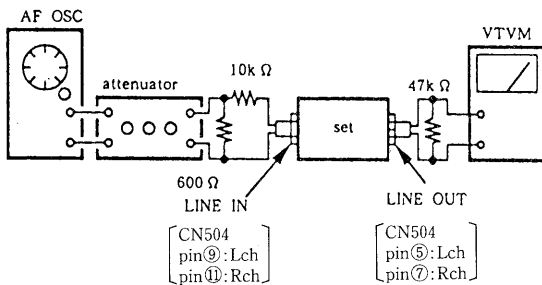

Standard Input Level

input terminal	LINE IN
source impedance	10kΩ
input level	0.25V (-10dB)

Standard Output Level

output terminal	LINE OUT
load impedance	47kΩ
output level	0.44V (-5dB)

Test tape

Type	Signal	Used for
P-4-A100	10kHz, -10dB	Azimuth Adjustment
P-4-L300	315Hz, 0dB	PB Level Adjustment
WS-48B	3kHz, 0dB	Tape Speed Adjustment

Record/Playback Head Azimuth Adjustment

DECK A DECK B

Procedure :

- Mode: FWD playback

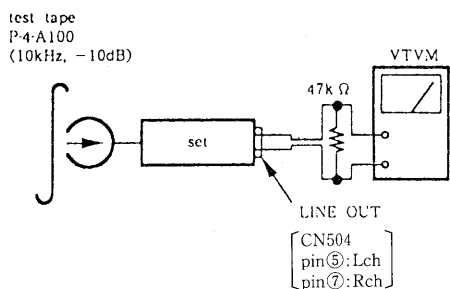

- Turn the adjustment screw for the maximum output levels. If these levels do not match, turn the adjustment screw until both of output levels match together within 1dB.

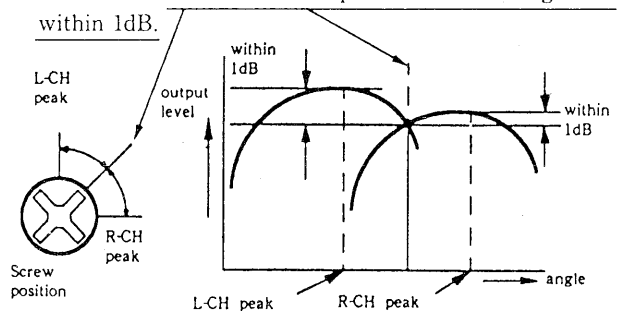

- Phase Check
Mode: playback

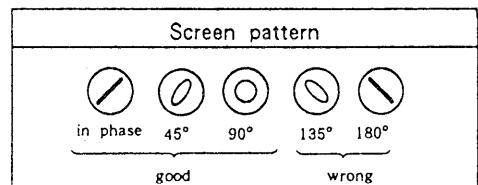
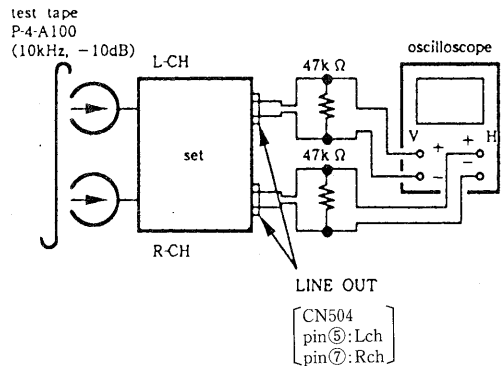

- Set in the REV mode and repeat the step 1-3.
- After the adjustment, lock the screws with locking compound.

Adjustment Location : Record/playback head

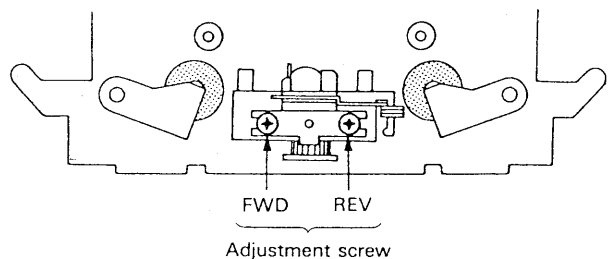

Tape Speed Adjustment DECK A DECK B

Procedure :

Mode: playback

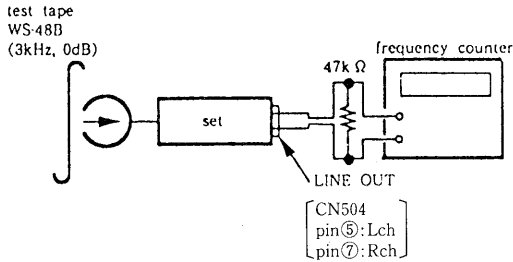

Perform high speed adjustment before normal speed adjustment.

(High speed adjustment)

1. Continue pressing the SYNCHRO DUBBING HIGH SPEED switch.
2. Check that frequency counter reading is within the standard value $6,000 \pm 60\text{Hz}$.
3. If out of the standard, adjust each RV72 so that the frequency counter reading satisfies $6,000 \pm 60\text{Hz}$ on both A and B decks.
4. Change over to Rev playback status, and repeat the above steps 1 to 3.

(Normal speed adjustment)

1. Continue pressing the SYNCHRO DUBBING NORM SPEED switch.
2. Check that the frequency counter reading is within the standard value $3,000 \pm 30\text{Hz}$.
3. If out of the standard, adjust each RV71 so that the frequency counter reading satisfies $3,000 \pm 30\text{Hz}$ on both A and B decks.
4. Change over to REV playback status, and repeat the above steps 1 to 3.

Frequency difference between the beginning and the end of the tape should be within 3%.

Frequency difference between deck A and deck B the beginning of the tape should be within 1.0%.

Adjustment Location :

MD-A, MD-B board

Playback Level Adjustment

DECK A DECK B

Procedure :

Mode: playback

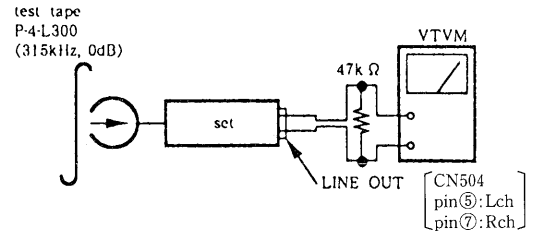

Adjust RV11 (L-CH), RV21 (R-CH) so that the reading on VTVM meets the adjustment limits below.

Adjustment Limits :

LINE OUT level: $-7.7 \pm 0.5\text{dB}$ (0.30 – 0.33V)

Level difference between channels: less than 0.5dB

Check that the LINE OUT level does not change in playback mode while changing the mode from playback to stop several times.

Adjustment Location : MD-A, MD-B board

Record Bias Adjustment DECK B

Setting :

REC LEVEL control : Standard Record (See page 7).

Procedure :

1. Mode : record

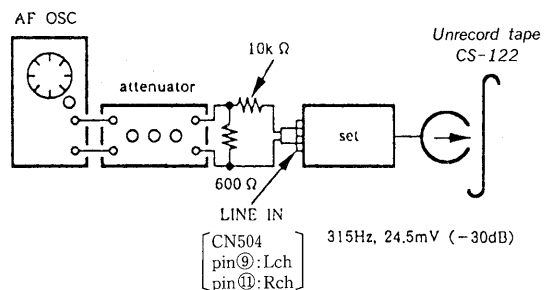

2. Mode : playback

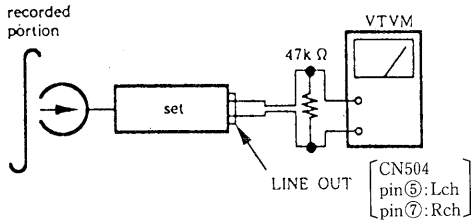

Playback the signal recorded in step 1.
 Confirm that the 10kHz playback output is $0 \pm 0.5\text{dB}$ relative to the 315Hz output. If necessary, adjust RV12 (L-CH), RV22 (R-CH) and repeat the steps given above.

Adjustment Location : MD-B board

Record Level Adjustment **DECK B**

Setting :

REC LEVEL control : Standard Record (See page 7).

Procedure :

1. Mode: record

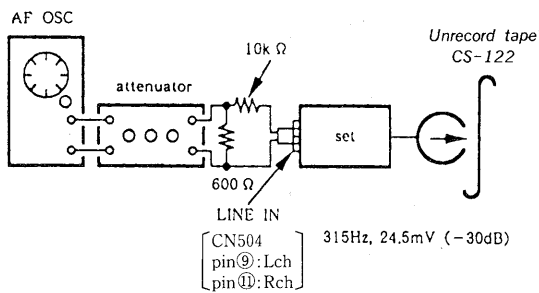

2. Mode: playback

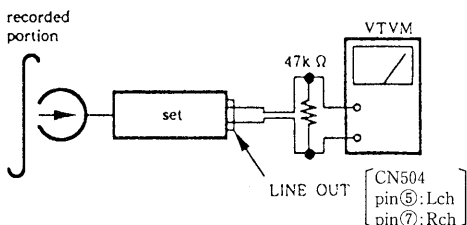

3. Playback the signal recorded in step 1.

Confirm that the signal level is within the adjustment limits below. If necessary, adjust RV101 (L-CH), RV201 (R-CH) and repeat the step 1-2.

Adjustment Limits : $-7\text{dB} \pm 0.5\text{dB}$ (0.33 - 0.36V)

Adjustment Location : MAIN board (component side)

- Adjustment Parts Location Diagrams -

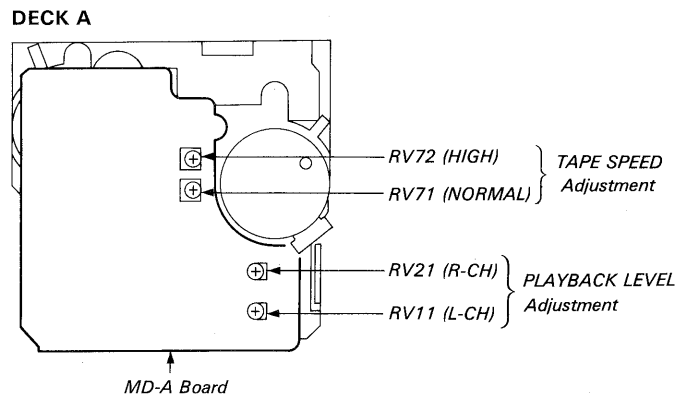
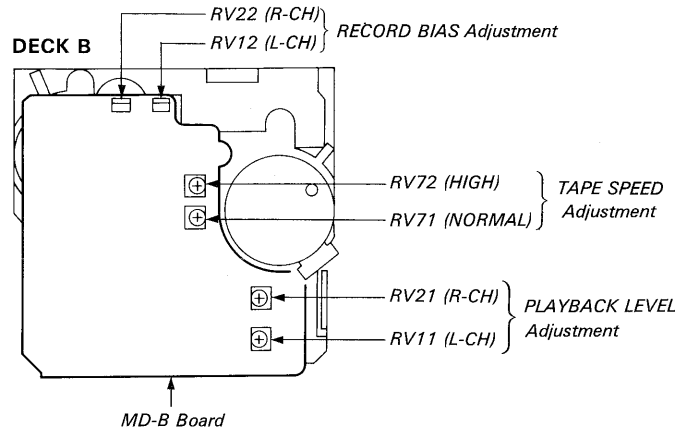

MAIN BOARD (COMPONENT SIDE)

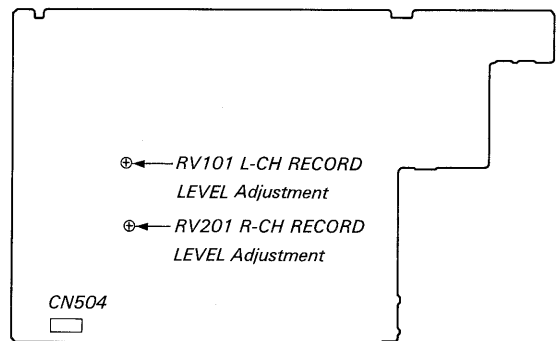

**SECTION 5
DIAGRAMS**

5-1. CIRCUIT BOARDS LOCATION

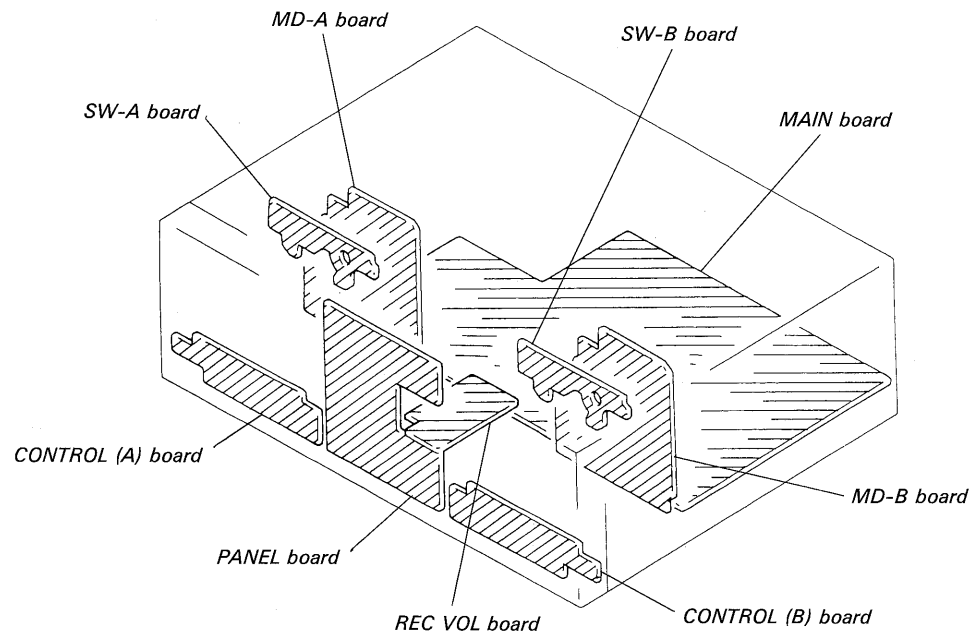

5-2. SEMICONDUCTOR LEAD LAYOUTS

TA7272P

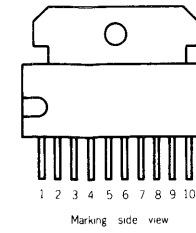

**2SC2603-EF
DTA114ES
DTA144ES
DTC114ES
DTC143TS**



NJL5165K-B

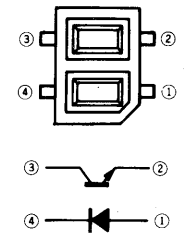

**2SA1175-HFE
2SC3623A-LK
DTC144ES**

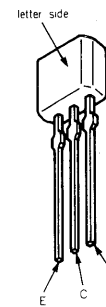

2SD1622-S

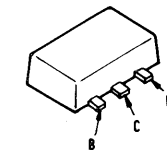

SEL2210S-C

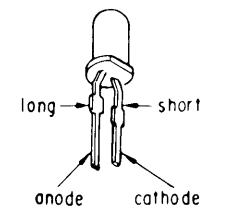

**1N4148M
10E2N**

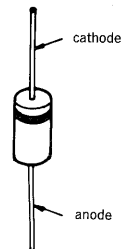

SEL2213C-C

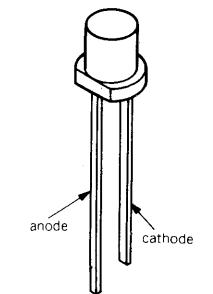

2SA1602

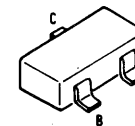

2SB1013-4



1SS355

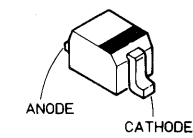

**2SB1094-LK
2SD2012**



**HZS6A1L
HZS7A1L
HZS9A2L**

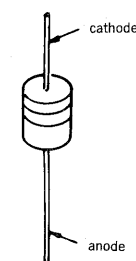

● Semiconductor Location

Ref. No.	Location	Ref. No.	Location
D31	G-23	Q51	E-24
D101	C-4	Q52	E-24
D102	F-10	Q53	F-24
D201	C-4	Q71(MD-A)	G-19
D202	F-10	Q71(MD-B)	G-27
D401	B-5	Q101	G-2
D402	B-5	Q102	C-3
D501	G-9	Q201	F-2
D504	E-5	Q202	B-2
D701	B-7	Q501	F-2
D702	B-7	Q502	B-3
D703	B-6	Q503	B-3
D704	B-6	Q504	G-3
D705	B-8	Q505	G-3
D706	B-8	Q506	G-9
D707	B-10	Q510	E-6
D708	B-9	Q511	D-6
D709	B-8	Q512	E-9
D801	F-3	Q514	D-6
D802	F-9	Q515	E-6
D803	G-9	Q516	D-6
D804	G-10	Q601	G-5
D805	B-12	Q701	A-9
D806	B-12	Q702	A-8
D807	E-8	Q703	B-8
D808	B-7	Q704	A-7
D809	B-6	Q705	F-8
		Q706	F-9
		Q801	F-9
IC31(MD-A)	G-17	Q802	D-10
IC31(MD-B)	G-24	Q803	D-10
IC81(SW-A)	C-22	Q804	F-3
IC81(SW-B)	C-29	Q805	F-3
IC501	G-2	Q806	I-6
IC502	C-2	Q807	B-12
IC503	E-3	Q808	B-12
IC504	G-5	Q810	D-3
IC505	G-4	Q813	F-9
IC506	C-3	Q814	F-9
IC507	C-4	Q815	G-10
IC701	B-10	Q816	G-10
IC801	F-10		
IC802	F-12		
IC803	E-5		
IC804	G-12		
IC805	E-9		
IC806	B-12		

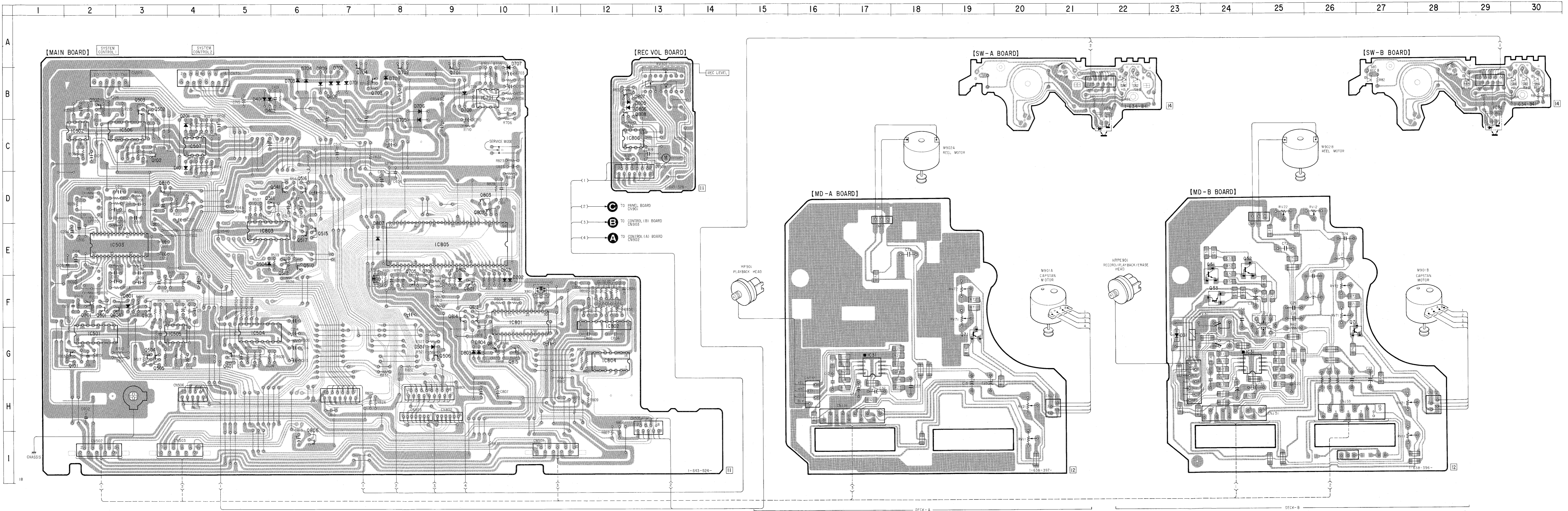

Note:
 ● ○ : parts extracted from the component side.

5-4. SCHEMATIC DIAGRAMS - MAIN section -

Note:

- All capacitors are in μF unless otherwise noted. pF: μF 50WV or less are not indicated except for electrolytics and tantalums.
- All resistors are in Ω and $\frac{1}{4}\text{W}$ or less unless otherwise specified.
- \triangle : internal component.
- \square : nonflammable resistor.
- \square : B+ Line
- \square : B- Line
- \square : adjustment for repair.
- Voltage is dc with respect to ground under no-signal (detuned) conditions. no mark: REC
- Voltages are taken with a VOM (input impedance 10M Ω). Voltage variations may be noted due to normal production tolerances.
- Signal path.
- \square : PB (DECK A)
- \square : PB (DECK B)
- \square : REC (DECK B)

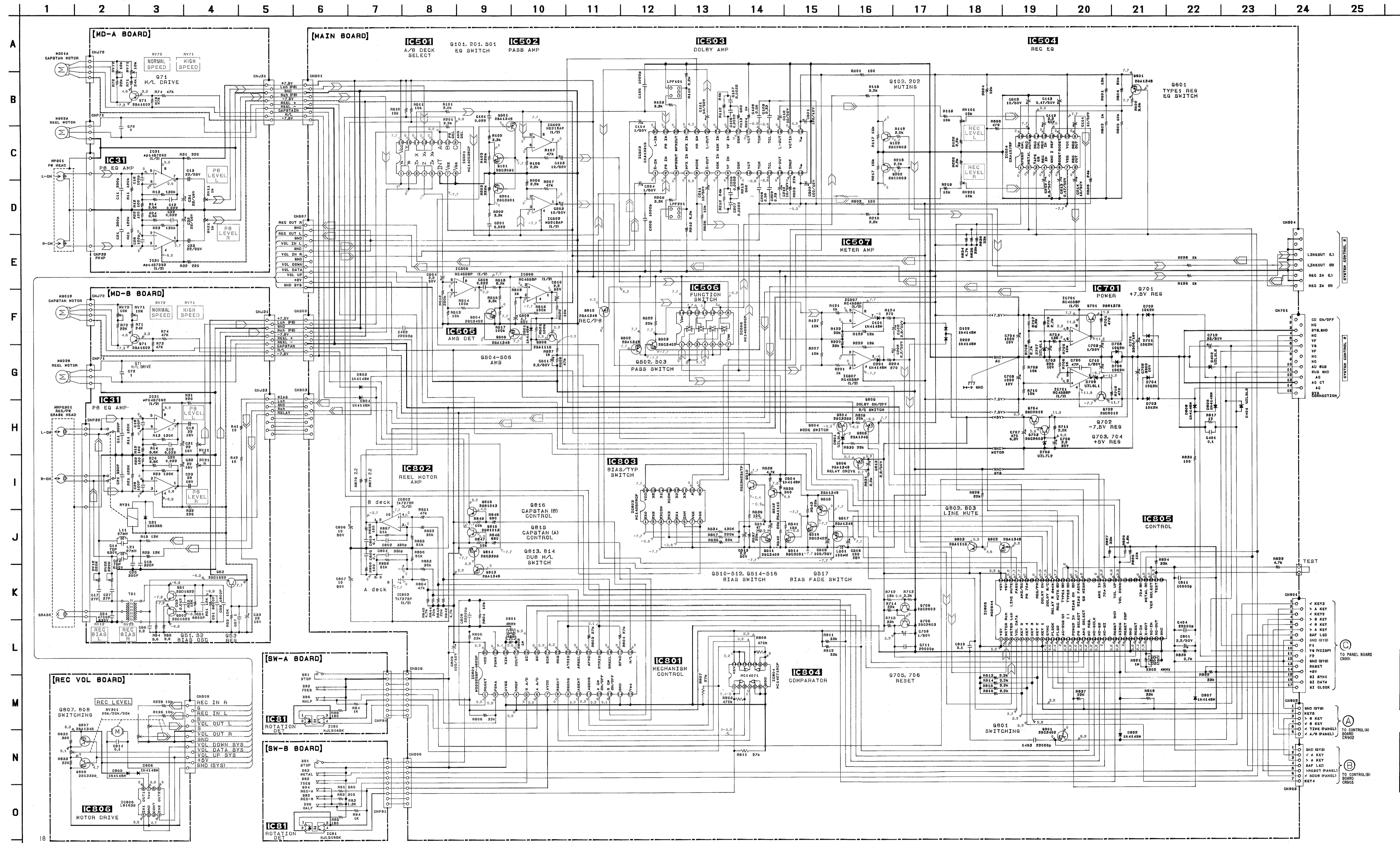

• IC Block Diagrams

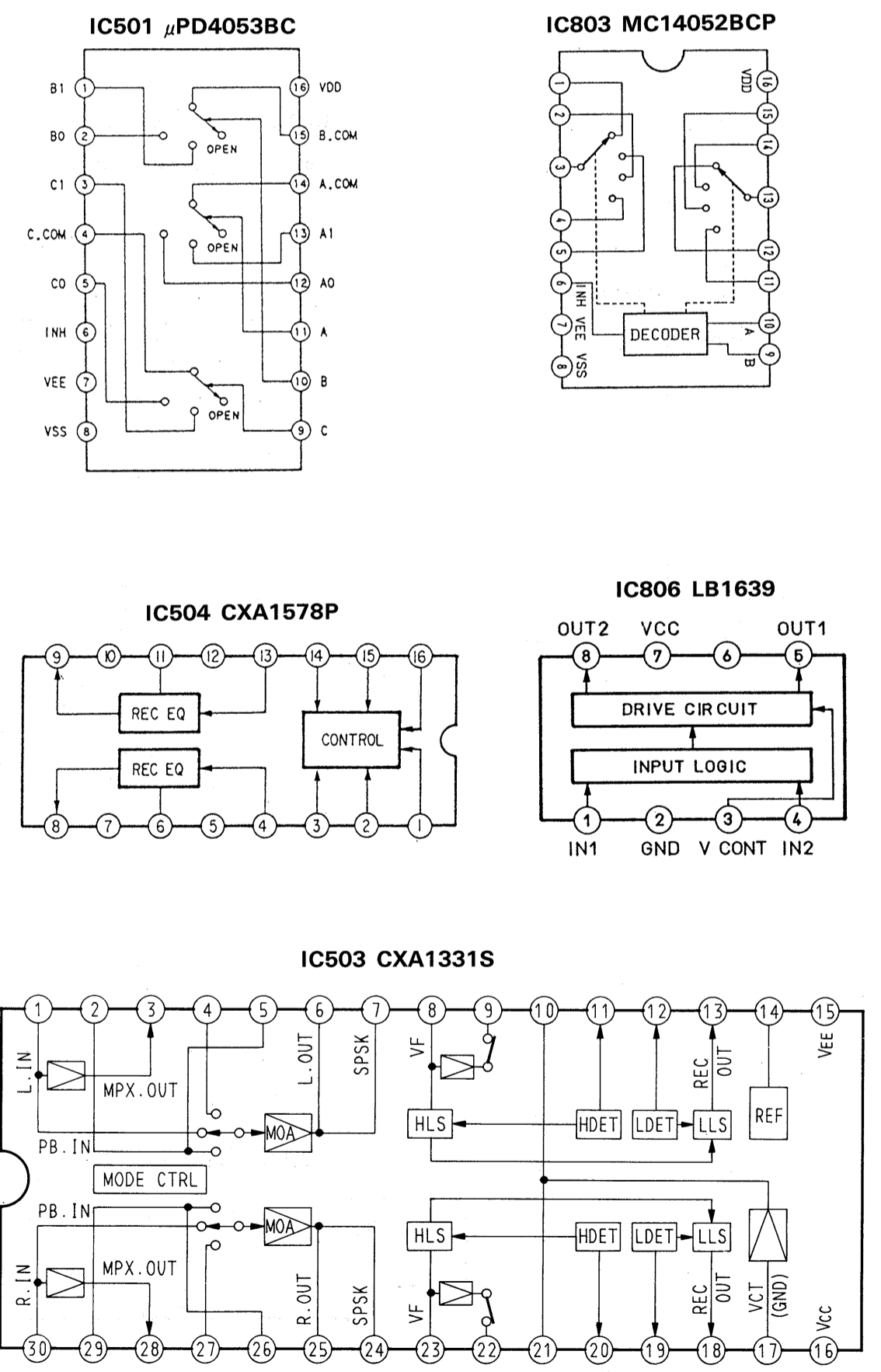

5-5. PRINTED WIRING BOARDS - PANEL section -

• See page 10,11 Circuit boards location and Semiconductor lead layouts.

Note:

• ○ — : parts extracted from the component side.

● Semiconductor Location

Ref. No.	Location
D901	E-2
D902	E-3
D903	E-4
D904	D-4
D905	H-8
D906	B-5
IC901	B-3
Q501	D-2

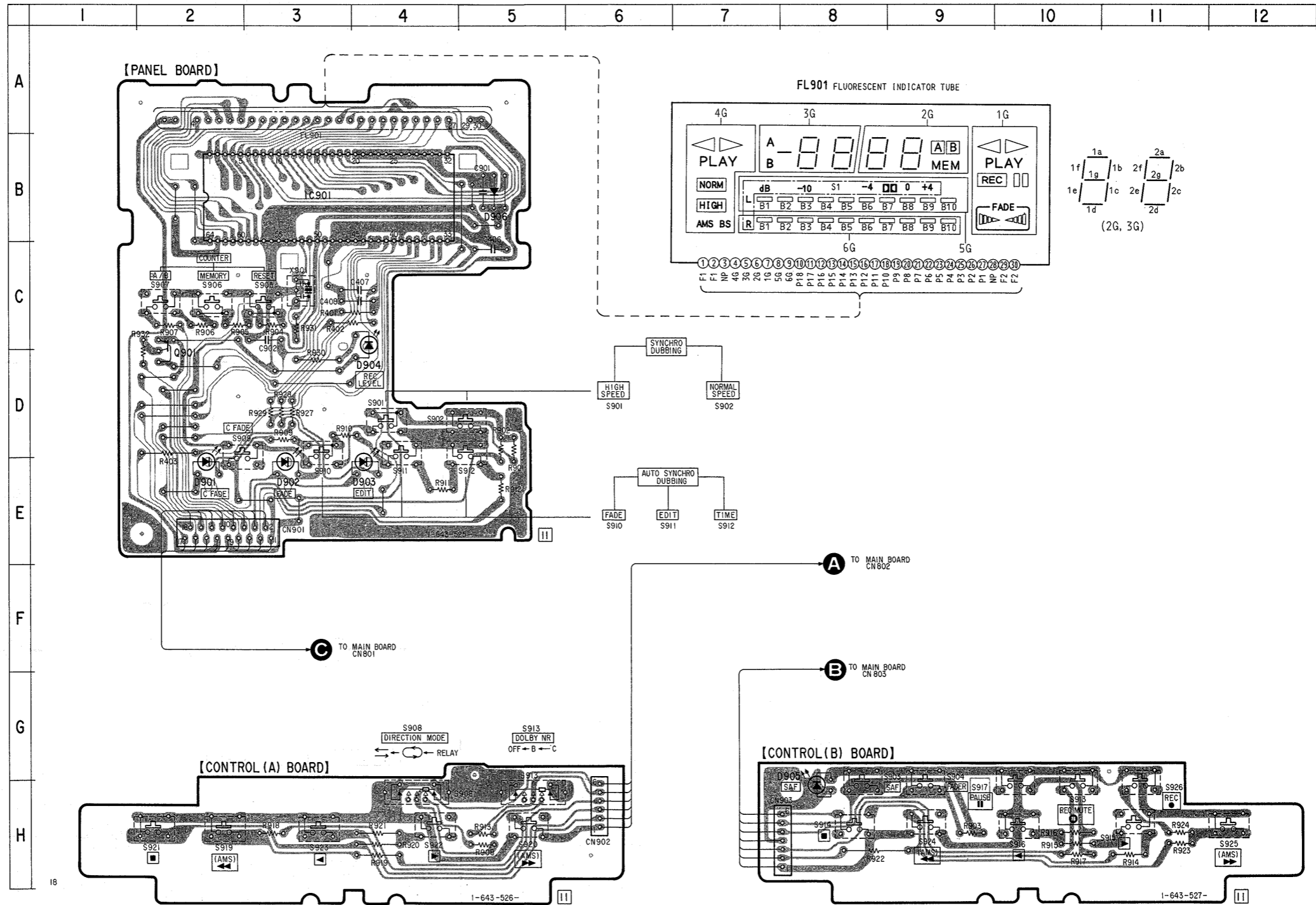

5-6. SCHEMATIC DIAGRAMS – PANEL section –

Note:

- All capacitors are in μF unless otherwise noted. pF : μF 50WV or less are not indicated except for electrolytics and tantalums.
- All resistors are in Ω and $\frac{1}{4}\text{W}$ or less unless otherwise specified.
- Δ : internal component.
- --- : B+ Line
- Voltage is dc with respect to ground under no-signal (detuned) conditions. no mark : REC
- Voltages are taken with a VOM (Input Impedance $10\text{M}\Omega$). Voltage variations may be noted due to normal production tolerances.

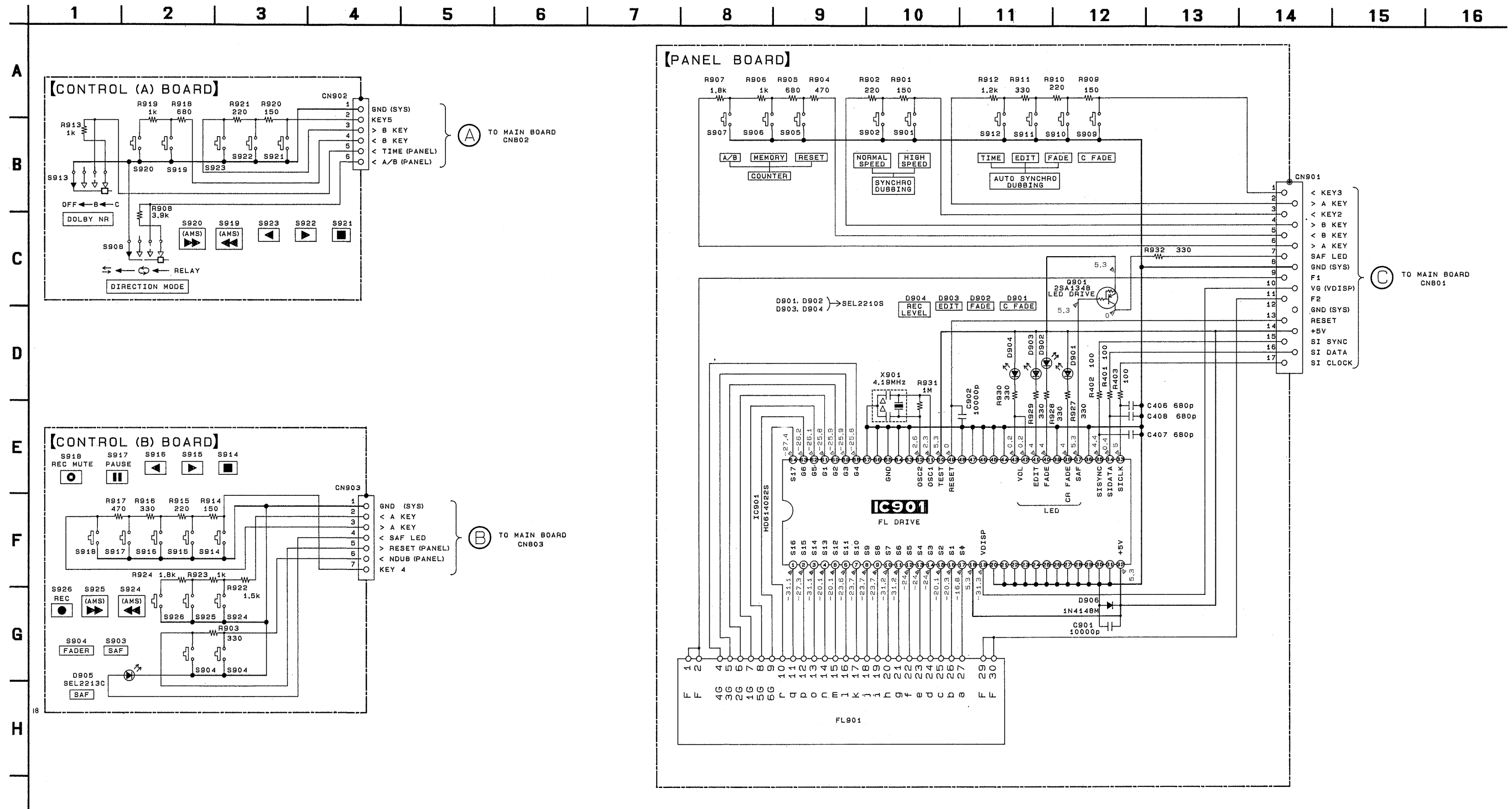

SECTION 6 EXPLODED VIEWS

NOTE:

• -XX, -X mean standardized parts, so they may have some differences from the original one.

• Color Indication of Appearance Parts
Example:

KNOB, BALANCE(WHITE)...(RED)

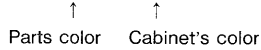

- Items marked " * " are not stocked since they are seldom required for routine service. Some delay should be anticipated when ordering these items.
- The mechanical parts with no reference number in the exploded views are not supplied.
- hardware (#mark) list is given in the last of this parts list.

G: Germany EA: Saudi Arabia

IT: Italian AUS: Australian

6-1. OVERALL SECTION

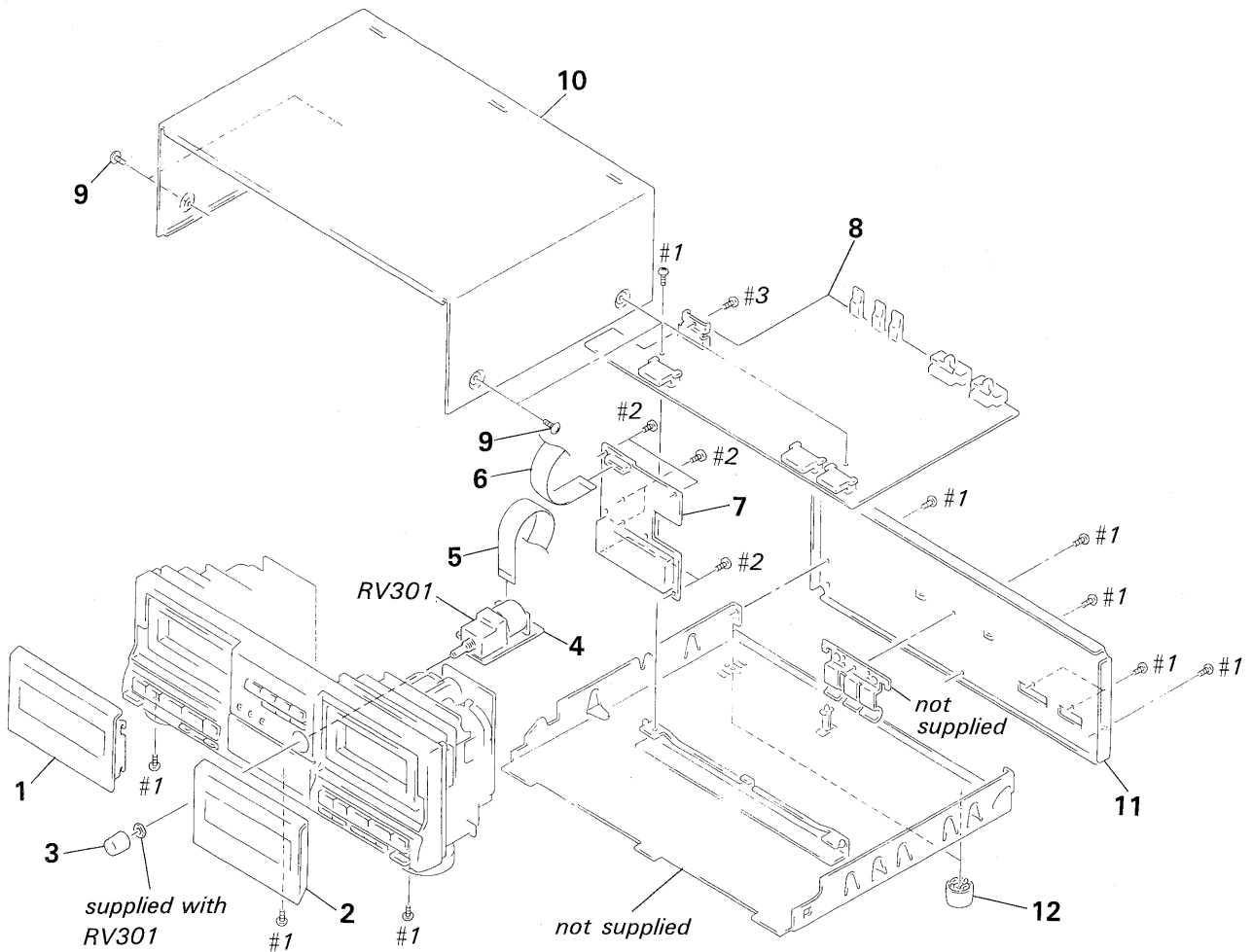

Ref. No.	Part No.	Description	Remark
1	X-3364-710-1	LID (A) ASSY, CASSETTE (AEP, G, UK, E, EA, AUS)	
1	X-3364-711-1	LID (A) ASSY, CASSETTE (IT)	
2	X-3364-714-1	LID (B) ASSY, CASSETTE (AEP, G, UK, E, EA, AUS)	
2	X-3364-718-1	LID (B) ASSY, CASSETTE (IT)	
3	4-950-651-21	KNOB (DIA. 16), ROUND (IT)	
3	4-950-651-31	KNOB (DIA. 16), ROUND (AEP, G, UK, E, EA, AUS)	
* 4	1-643-528-11	REC VOL BOARD	
* 5	1-574-726-11	WIRE, FLAT TYPE (13 CORE)	

Ref. No.	Part No.	Description	Remark
6	1-690-907-11	WIRE (FLAT TYPE) (17 CORE)	
* 7	A-2006-747-A	PANEL BOARD, COMPLETE	
* 8	A-2006-746-A	MAIN BOARD, COMPLETE	
9	3-363-099-01	SCREW (CASE +3X8 TP2)	
* 10	4-939-803-31	CASE (AEP, G, UK, E, EA, AUS)	
* 10	4-939-803-71	CASE (IT)	
* 11	3-377-136-31	PANEL, BACK (AEP, IT, UK, E, EA, AUS)	
* 11	3-377-136-41	PANEL, BACK (G)	
12	4-931-169-01	FOOT	
RV301	1-241-891-11	RES, VAR, CARBON 20KX3 (REC LEVEL)	

6-2. FRONT PANEL SECTION

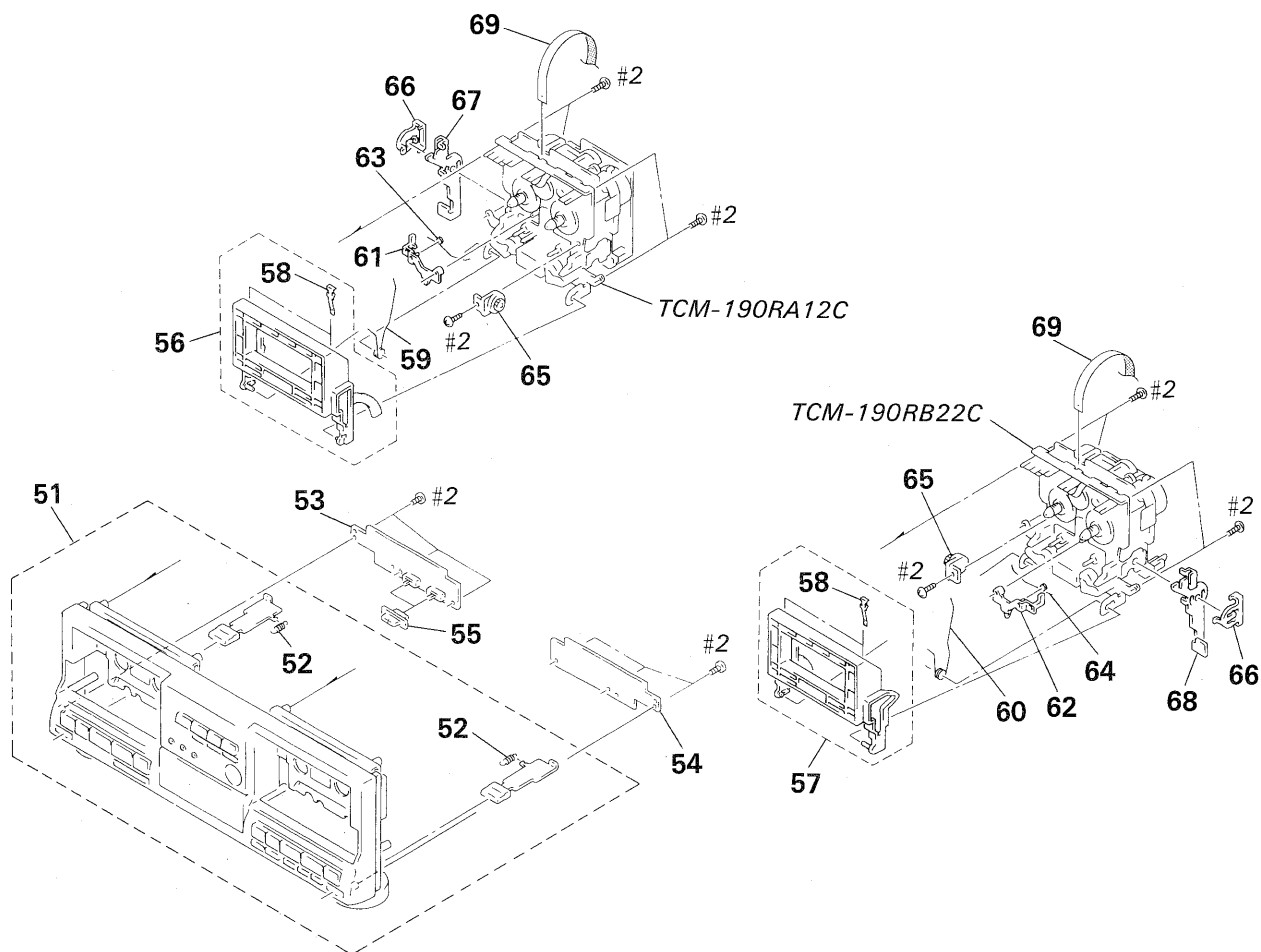

Ref. No.	Part No.	Description	Remark
51	X-3364-708-1	PANEL ASSY, FRONT (AEP, G, UK, E, EA, AUS)	
51	X-3364-709-1	PANEL ASSY, FRONT (IT)	
52	3-662-752-21	SPRING, TENSION	
* 53	1-643-526-11	CONTROL (A) BOARD	
* 54	1-643-527-11	CONTROL (B) BOARD	
55	3-377-120-01	KNOB (SLIDE) (AEP, G, UK, E, EA, AUS)	
55	3-377-120-11	KNOB (SLIDE) (IT)	
56	X-3340-194-1	HOLDER (L) ASSY, CASSETTE	
57	X-3340-195-1	HOLDER (R) ASSY, CASSETTE	
58	3-308-823-11	SPRING	
59	3-354-959-01	SPRING (LOADING L), TORSION	

Ref. No.	Part No.	Description	Remark
60	3-354-960-01	SPRING (LOADING R), TORSION	
61	3-354-955-01	LEVER (EJ SAFTY LEVER L)	
62	3-354-956-01	LEVER (EJ SAFTY LEVER R)	
63	3-354-961-01	SPRING (EJ SAFTY SPRING L)	
64	3-354-962-01	SPRING (EJ SAFTY SPRING R)	
65	3-354-963-01	DAMPER	
66	3-354-957-01	JOINT (LOCK LEVER)	
* 67	3-363-638-01	LEVER (LOCK LEVER L)	
* 68	3-363-639-01	LEVER (LOCK LEVER R)	
69	1-690-906-11	WIRE (FLAT TYPE) (9 CORE)	

6-3. MECHANISM SECTION 1

(TCM-190RA12C)
(TCM-190RB22C)

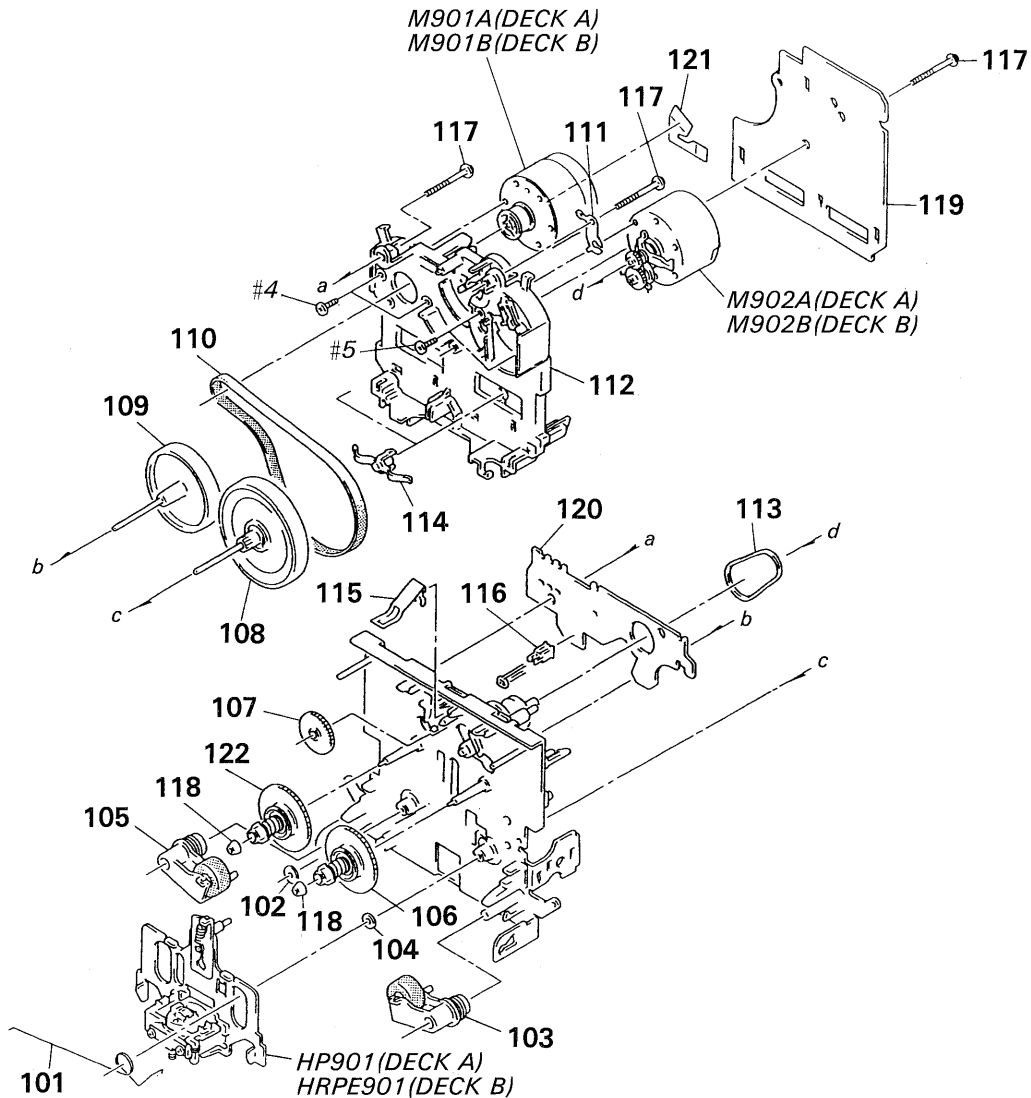

Ref. No.	Part No.	Description	Remark	Ref. No.	Part No.	Description	Remark
101	3-359-455-01	SPRING, TORSION		116	3-343-419-01	HOLDER (S SENSER A)	
102	3-356-714-01	WASHER		117	3-359-414-01	SCREW (+PTPWH 2X23)	
103	X-3359-408-1	LEVER (PINCH LEVER FWD) ASSY		118	3-362-308-01	CAP (REEL)	
104	3-356-713-01	WASHER		* 119	A-2006-399-A	MD-A BORAD, COMPLETE (DECK A)	
105	X-3359-409-1	LEVER (PINCH LEVER REV) ASSY		* 119	A-2006-400-A	MD-B BOARD, COMPLETE (DECK B)	
106	X-3359-404-1	TABLE ASSY, REEL		* 120	1-634-841-14	SW-A BOARD (DECK A)	
107	3-359-424-01	GEAR (REV GEAR)		* 120	1-634-841-14	SW-B BOARD (DECK B)	
108	X-3359-406-1	FLYWHEEL (FWD) COMPLETE ASSY (DECK A)		121	1-638-983-11	MOTOR FLEXIBLE BOARD	
108	X-3364-554-1	FLYWHEEL (FWD) ASSY (DECK B)		122	X-3362-078-1	TABLE ASSY (B), REEL	
109	X-3359-410-1	FLYWHEEL (REV) ASSY		HP901	A-2003-837-A	BASE ASSY, HEAD (PB) (DECK A)	
110	3-359-417-01	BELT (FLAT), CAPSTAN		HRPE901A-2003-838-A	BASE ASSY, HEAD (REC/PB/ERASE) (DECK B)		
111	3-359-450-01	PLATE, GROUND		M901A	X-3359-417-1	MOTOR ASSY (CAPSTAN) (DECK A)	
* 112	3-359-436-01	BASE (THRUST RETAINER), FITTING		M901B	X-3359-417-1	MOTOR ASSY (CAPSTAN) (DECK B)	
113	3-359-466-01	BELT (FR), SQUARE		M902A	X-3363-501-1	MOTOR ASSY (REEL) (DECK A)	
114	3-575-321-00	RETAINER, THRUST, CAPSTAN		M902B	X-3363-501-1	MOTOR ASSY (REEL) (DECK B)	
115	3-359-430-01	SPRING (CASSETTE RETAINER), LEAF					

6-4. MECHANISM SECTION 2

(TCM-190RA12C)
(TCM-190RB22C)

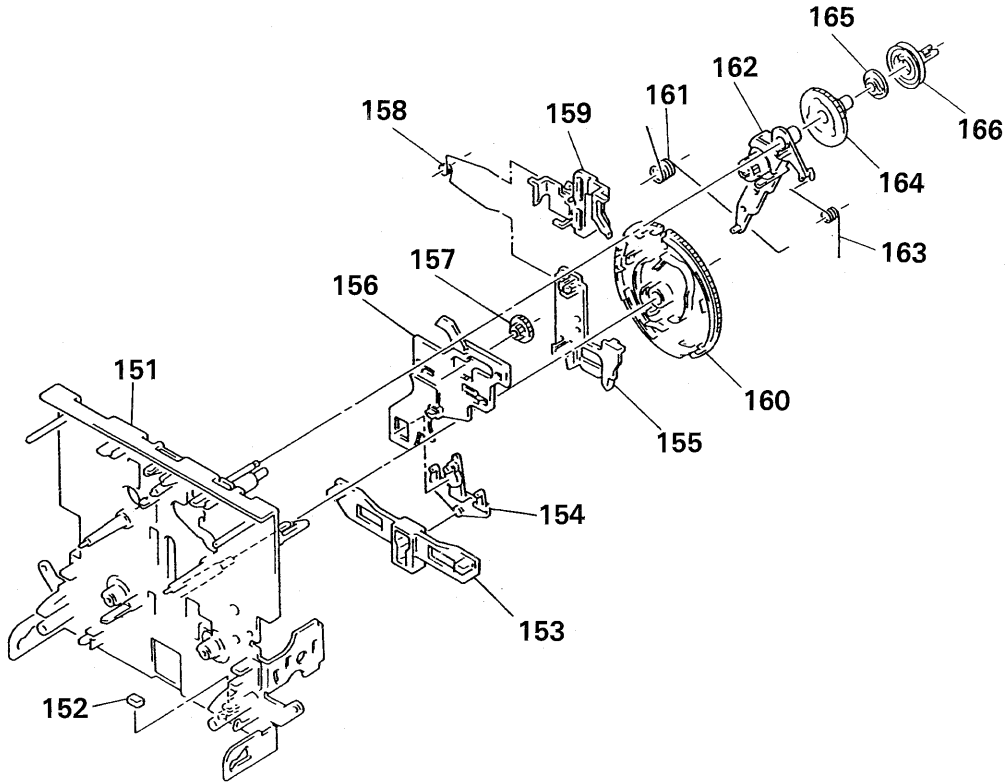

Ref. No.	Part No.	Description	Remark	Ref. No.	Part No.	Description	Remark
151	X-3363-790-1	CHASSIS ASSY, MECHANICAL (DECK A)		159	3-359-429-01	SLIDER (BRAKE PLATE)	
151	X-3359-415-1	CHASSIS ASSY, MECHANICAL (DECK B)		160	3-359-420-01	GEAR (CAM GEAR)	
152	3-359-469-01	SPACER		161	3-359-456-01	SPRING (TRIGGER SPRING), TORSION	
* 153	3-359-425-01	SLIDER (REVERSE SLIDER)		162	X-3359-405-1	LEVER (FR ARM) ASSY	
154	3-359-426-01	LEVER (REVERSE LEVER)		163	3-359-453-01	SPRING (FR ARM), TORSION	
* 155	3-359-427-01	SLIDER (LEVERSE SLIDER)		164	3-359-419-01	GEAR (FR GEAR)	
* 156	3-359-415-01	SLIDER (TRIGGER SLIDER)		165	3-359-421-01	CLUTCH (REEL DISK)	
157	3-359-448-01	GEAR (TRIGGER)		166	3-359-418-01	PULLEY (FR PULLEY)	
158	3-359-454-01	SPRING, TORSION					

SECTION 7 ELECTRICAL PARTS LIST

CONTROL (A)

CONTROL (B)

MAIN

NOTE:

- Due to standardization, replacements in the parts list may be different from the parts specified in the diagrams or the components used on the set.
- -XX, -X mean standardized parts, so they may have some differences from the original one.
- RESISTORS
All resistors are in ohms
METAL: Metal-film resistor
METAL OXIDE: Metal Oxide-film resistor
F: nonflammable

- Items marked " * " are not stocked since they are seldom required for routine service. Some delay should be anticipated when ordering these items.
- SEMICONDUCTORS
In each case, u: μ , for example:
uA...: μ A..., uPA...: μ PA...,
uPB...: μ PB..., uPC...: μ PC...,
uPD...: μ PD...
- CAPACITORS
uF: μ F
- COILS
uH: μ H

When indication parts by reference number, please include the board name.

The components identified by mark Δ or dotted line with mark Δ are critical for safety. Replace only with part number specified.

Les composants identifiés par une marque Δ sont critiques pour la sécurité. Ne les remplacer que par une pièce portant le numéro spécifié.

Ref. No.	Part No.	Description	Remark	Ref. No.	Part No.	Description	Remark
* -----	1-643-526-11	CONTROL (A) BOARD *****				< RESISTOR >	
		< CONNECTOR >		R903	1-249-411-11	CARBON 330 5% 1/4W	
* CN902	1-564-499-11	PIN, CONNECTOR 6P		R914	1-249-407-11	CARBON 150 5% 1/4W	
		< RESISTOR >		R915	1-249-409-11	CARBON 220 5% 1/4W	
R908	1-249-424-11	CARBON 3.9K 5% 1/4W		R916	1-249-411-11	CARBON 330 5% 1/4W	
R913	1-249-417-11	CARBON 1K 5% 1/4W		R917	1-249-413-11	CARBON 470 5% 1/4W	
R918	1-249-415-11	CARBON 680 5% 1/4W		R922	1-249-419-11	CARBON 1.5K 5% 1/4W	
R919	1-249-417-11	CARBON 1K 5% 1/4W		R923	1-249-417-11	CARBON 1K 5% 1/4W	
R920	1-249-407-11	CARBON 150 5% 1/4W		R924	1-249-420-11	CARBON 1.8K 5% 1/4W	
R921	1-249-409-11	CARBON 220 5% 1/4W				< SWITCH >	
		< SWITCH >		S903	1-554-303-21	SWITCH, TACTILE (SAF)	
S908	1-572-378-11	SWITCH, SLIDE (DIRECTION MODE)		S904	1-554-303-21	SWITCH, TACTILE (FADER)	
S913	1-572-378-11	SWITCH, SLIDE (DOLBY NR)		S914	1-554-303-21	SWITCH, TACTILE (STOP)	
S919	1-554-303-21	SWITCH, TACTILE (AMS REW)		S915	1-554-303-21	SWITCH, TACTILE (FWD)	
S920	1-554-303-21	SWITCH, TACTILE (AMS FF)		S916	1-554-303-21	SWITCH, TACTILE (REV)	
S921	1-554-303-21	SWITCH, TACTILE (STOP)		S917	1-554-303-21	SWITCH, TACTILE (PAUSE)	
S922	1-554-303-21	SWITCH, TACTILE (FWD)		S918	1-554-303-21	SWITCH, TACTILE (REC MUTE)	
S923	1-554-303-21	SWITCH, TACTILE (REW)		S924	1-554-303-21	SWITCH, TACTILE (AMS REW)	
*****				S925	1-554-303-21	SWITCH, TACTILE (AMS FF)	
* -----	1-643-527-11	CONTROL (B) BOARD *****		S926	1-554-303-21	SWITCH, TACTILE (REC)	
		< CONNECTOR >		*****			
* CN903	1-564-500-11	PIN, CONNECTOR 7P		* A-2006-746-A	MAIN BOARD, COMPLETE *****		
		< DIODE >		* 4-942-204-01	PLATE, GROUND		
D905	8-719-302-23	DIODE SEL2213C-C		7-685-645-79	SCREW +BVTP 3X6 TYPE2 N-S		
						< CAPACITOR >	
				C101	1-136-157-00	FILM 0.022uF 5% 50V	
				C102	1-126-161-11	ELECT 2.2uF 20% 50V	
				C103	1-126-059-11	ELECT 10uF 20% 50V	
				C104	1-126-301-11	ELECT 1uF 20% 50V	
				C105	1-162-294-31	CERAMIC 0.001uF 10% 50V	

MAIN

Ref. No.	Part No.	Description	Remark			Ref. No.	Part No.	Description	Remark		
C106	1-130-475-00	MYLAR	0.0022uF	5%	50V	C711	1-101-005-00	CERAMIC	22000PF		50V
C107	1-130-475-00	MYLAR	0.0022uF	5%	50V	C712	1-126-867-11	ELECT	33uF	20%	50V
C108	1-136-174-00	FILM	0.56uF	5%	50V	C720	1-162-215-31	CERAMIC	47PF	5%	50V
C109	1-136-171-00	FILM	0.33uF	5%	50V	C801	1-126-161-11	ELECT	2.2uF	20%	50V
C110	1-126-059-11	ELECT	10uF	20%	50V	C802	1-162-288-31	CERAMIC	330PF	10%	50V
C111	1-126-059-11	ELECT	10uF	20%	50V	C803	1-136-165-00	FILM	0.1uF	5%	50V
C112	1-126-162-11	ELECT	3.3uF	20%	50V	C804	1-162-288-31	CERAMIC	330PF	10%	50V
C113	1-126-300-11	ELECT	0.47uF	20%	50V	C805	1-136-165-00	FILM	0.1uF	5%	50V
C114	1-126-059-11	ELECT	10uF	20%	50V	C806	1-126-059-11	ELECT	10uF	20%	50V
C201	1-136-157-00	FILM	0.022uF	5%	50V	C807	1-126-059-11	ELECT	10uF	20%	50V
C202	1-126-161-11	ELECT	2.2uF	20%	50V	C808	1-101-005-00	CERAMIC	22000PF		50V
C203	1-126-059-11	ELECT	10uF	20%	50V	C809	1-124-994-11	ELECT	100uF	20%	10V
C204	1-126-301-11	ELECT	1uF	20%	50V	C810	1-136-165-00	FILM	0.1uF	5%	50V
C205	1-162-294-31	CERAMIC	0.001uF	10%	50V	C811	1-161-379-00	CERAMIC	0.01uF	20%	25V
C206	1-130-475-00	MYLAR	0.0022uF	5%	50V	C813	1-126-161-11	ELECT	2.2uF	20%	50V
C207	1-130-475-00	MYLAR	0.0022uF	5%	50V	< CONNECTOR >					
C208	1-136-174-00	FILM	0.56uF	5%	50V	* CN501	1-580-784-11	CONNECTOR, BOARD TO BOARD			
C209	1-136-171-00	FILM	0.33uF	5%	50V	* CN502	1-580-784-11	CONNECTOR, BOARD TO BOARD			
C210	1-126-059-11	ELECT	10uF	20%	50V	* CN503	1-580-784-11	CONNECTOR, BOARD TO BOARD			
C211	1-126-059-11	ELECT	10uF	20%	50V	* CN504	1-566-858-11	SOCKET, CONNECTOR 11P			
C212	1-126-162-11	ELECT	3.3uF	20%	50V	* CN505	1-568-828-11	SOCKET, CONNECTOR 9P			
C213	1-126-300-11	ELECT	0.47uF	20%	50V	* CN506	1-568-828-11	SOCKET, CONNECTOR 9P			
C214	1-126-059-11	ELECT	10uF	20%	50V	* CN507	1-568-832-11	SOCKET, CONNECTOR 13P			
C401	1-164-159-11	CERAMIC	0.1uF		50V	* CN701	1-566-859-11	SOCKET, CONNECTOR 15P			
C402	1-101-005-00	CERAMIC	22000PF		50V	* CN801	1-568-836-11	SOCKET, CONNECTOR 17P			
C403	1-101-005-00	CERAMIC	22000PF		50V	* CN802	1-564-340-00	PIN, CONNECTOR 6P			
C404	1-101-005-00	CERAMIC	22000PF		50V	* CN803	1-564-341-11	PIN, CONNECTOR 7P			
C501	1-124-994-11	ELECT	100uF	20%	10V	< DIODE >					
C502	1-124-994-11	ELECT	100uF	20%	10V	D101	8-719-987-63	DIODE	1N4148M		
C503	1-126-059-11	ELECT	10uF	20%	50V	D102	8-719-987-63	DIODE	1N4148M		
C504	1-126-161-11	ELECT	2.2uF	20%	50V	D201	8-719-987-63	DIODE	1N4148M		
C508	1-126-163-11	ELECT	4.7uF	20%	50V	D202	8-719-987-63	DIODE	1N4148M		
C510	1-126-161-11	ELECT	2.2uF	20%	50V	D401	8-719-933-54	DIODE	HZS9A2L		
C511	1-126-161-11	ELECT	2.2uF	20%	50V	D402	8-719-933-54	DIODE	HZS9A2L		
C513	1-126-161-11	ELECT	2.2uF	20%	50V	D501	8-719-987-63	DIODE	1N4148M		
C514	1-124-910-11	ELECT	47uF	20%	50V	D504	8-719-987-63	DIODE	1N4148M		
C515	1-124-478-11	ELECT	100uF	20%	25V	D701	8-719-200-77	DIODE	10E2N		
C516	1-124-478-11	ELECT	100uF	20%	25V	D702	8-719-200-77	DIODE	10E2N		
C506	1-161-494-00	CERAMIC	0.022uF		25V	D703	8-719-200-77	DIODE	10E2N		
C701	1-124-887-00	ELECT	3300uF	20%	16V	D704	8-719-200-77	DIODE	10E2N		
C702	1-124-887-00	ELECT	3300uF	20%	16V	D705	8-719-200-77	DIODE	10E2N		
C703	1-126-101-11	ELECT	100uF	20%	16V	D706	8-719-200-77	DIODE	10E2N		
C704	1-124-473-11	ELECT	1000uF	20%	10V	D707	8-719-933-33	DIODE	HZS6A1L		
C705	1-124-473-11	ELECT	1000uF	20%	10V	D708	8-719-933-33	DIODE	HZS6A1L		
C706	1-126-161-11	ELECT	2.2uF	20%	50V	D709	8-719-000-78	DIODE	UZL-7L2		
C707	1-124-472-11	ELECT	470uF	20%	10V	D801	8-719-933-54	DIODE	HZS9A2L		
C708	1-126-301-11	ELECT	1uF	20%	50V						
C709	1-126-301-11	ELECT	1uF	20%	50V						
C710	1-126-301-11	ELECT	1uF	20%	50V						

MAIN

Ref. No.	Part No.	Description	Remark	Ref. No.	Part No.	Description	Remark
D802	8-719-987-63	DIODE 1N4148M		Q701	8-729-141-83	TRANSISTOR 2SB1094-LK	
D803	8-719-987-63	DIODE 1N4148M		Q702	8-729-209-15	TRANSISTOR 2SD2012	
D804	8-719-987-63	DIODE 1N4148M		Q703	8-729-620-05	TRANSISTOR 2SC2603-EF	
D807	8-719-987-63	DIODE 1N4148M		Q704	8-729-209-15	TRANSISTOR 2SD2012	
D808	8-719-987-63	DIODE 1N4148M		Q705	8-729-620-05	TRANSISTOR 2SC2603-EF	
D809	8-719-987-63	DIODE 1N4148M		Q706	8-729-620-05	TRANSISTOR 2SC2603-EF	
< IC >				Q801	8-729-900-80	TRANSISTOR DTC114ES	
IC501	8-759-140-53	IC UPD4053BC		Q802	8-729-900-61	TRANSISTOR DTA114ES	
IC502	8-759-634-51	IC M5218AP		Q803	8-729-119-76	TRANSISTOR 2SA1175-HFE	
IC503	8-752-059-55	IC CXA1331S		Q804	8-729-900-89	TRANSISTOR DTC144ES	
IC504	8-752-055-61	IC CXA1578P		Q805	8-729-900-65	TRANSISTOR DTA144ES	
IC505	8-759-945-58	IC RC4558P		Q806	8-729-900-61	TRANSISTOR DTA114ES	
IC506	8-759-000-49	IC MC14066BCP		Q810	8-729-900-61	TRANSISTOR DTA114ES	
IC507	8-759-945-58	IC RC4558P		Q813	8-729-900-61	TRANSISTOR DTA114ES	
IC701	8-759-945-58	IC RC4558P		Q814	8-729-900-89	TRANSISTOR DTC144ES	
IC801	8-759-635-94	IC M50925SP-482SP		Q815	8-729-801-84	TRANSISTOR 2SB1013-4	
IC802	8-759-207-05	IC TA7272P		Q816	8-729-801-84	TRANSISTOR 2SB1013-4	
IC803	8-759-000-48	IC MC14052BCP		< RESISTOR >			
IC804	8-759-240-71	IC TC4071BP		R101	1-249-421-11	CARBON 2.2K 5% 1/4W	
IC805	8-759-067-45	IC M50944-180SP		R102	1-249-423-11	CARBON 3.3K 5% 1/4W	
< COIL >				R103	1-247-887-00	CARBON 220K 5% 1/4W	
L501	1-408-080-00	INDUCTOR 100uH		R106	1-249-421-11	CARBON 2.2K 5% 1/4W	
< LOW PASS FILTER >				R107	1-249-437-11	CARBON 47K 5% 1/4W	
LPF101	1-236-087-11	FILTER, LOW PASS		R109	1-249-423-11	CARBON 3.3K 5% 1/4W	
LPF201	1-236-087-11	FILTER, LOW PASS		R110	1-249-428-11	CARBON 8.2K 5% 1/4W	
< TRANSISTOR >				R112	1-247-864-11	CARBON 24K 5% 1/4W	
Q101	8-729-900-74	TRANSISTOR DTC143TS		R113	1-249-414-11	CARBON 560 5% 1/4W	
Q102	8-729-620-05	TRANSISTOR 2SC2603-EF		R115	1-249-421-11	CARBON 2.2K 5% 1/4W	
Q201	8-729-900-74	TRANSISTOR DTC143TS		R117	1-249-431-11	CARBON 15K 5% 1/4W	
Q202	8-729-620-05	TRANSISTOR 2SC2603-EF		R118	1-249-421-11	CARBON 2.2K 5% 1/4W	
Q501	8-729-900-61	TRANSISTOR DTA114ES		R119	1-249-429-11	CARBON 10K 5% 1/4W	
Q502	8-729-900-61	TRANSISTOR DTA114ES		R120	1-249-421-11	CARBON 2.2K 5% 1/4W	
Q503	8-729-900-80	TRANSISTOR DTC114ES		R121	1-249-417-11	CARBON 1K 5% 1/4W	
Q504	8-729-900-80	TRANSISTOR DTC114ES		R122	1-249-436-11	CARBON 39K 5% 1/4W	
Q505	8-729-900-61	TRANSISTOR DTA114ES		R123	1-249-432-11	CARBON 18K 5% 1/4W	
Q506	8-729-119-76	TRANSISTOR 2SA1175-HFE		R124	1-249-410-11	CARBON 270 5% 1/4W	
Q510	8-729-141-30	TRANSISTOR 2SC3623A-LK		R126	1-249-417-11	CARBON 1K 5% 1/4W	
Q511	8-729-900-80	TRANSISTOR DTC114ES		R127	1-249-429-11	CARBON 10K 5% 1/4W	
Q512	8-729-119-76	TRANSISTOR 2SA1175-HFE		R201	1-249-421-11	CARBON 2.2K 5% 1/4W	
Q514	8-729-900-74	TRANSISTOR DTC143TS		R202	1-249-423-11	CARBON 3.3K 5% 1/4W	
Q515	8-729-900-61	TRANSISTOR DTA114ES		R203	1-247-887-00	CARBON 220K 5% 1/4W	
Q516	8-729-900-80	TRANSISTOR DTC114ES		R206	1-249-421-11	CARBON 2.2K 5% 1/4W	
Q517	8-729-900-61	TRANSISTOR DTA114ES		R207	1-249-437-11	CARBON 47K 5% 1/4W	
Q601	8-729-900-65	TRANSISTOR DTA144ES		R209	1-249-423-11	CARBON 3.3K 5% 1/4W	
				R210	1-249-428-11	CARBON 8.2K 5% 1/4W	
				R212	1-247-864-11	CARBON 24K 5% 1/4W	
				R213	1-249-414-11	CARBON 560 5% 1/4W	
				R215	1-249-421-11	CARBON 2.2K 5% 1/4W	

MAIN

Ref. No.	Part No.	Description	Remark		
R217	1-249-431-11	CARBON	15K	5%	1/4W
R218	1-249-421-11	CARBON	2.2K	5%	1/4W
R219	1-249-429-11	CARBON	10K	5%	1/4W
R220	1-249-421-11	CARBON	2.2K	5%	1/4W
R221	1-249-417-11	CARBON	1K	5%	1/4W
R222	1-249-436-11	CARBON	39K	5%	1/4W
R223	1-249-432-11	CARBON	18K	5%	1/4W
R224	1-249-410-11	CARBON	270	5%	1/4W
R226	1-249-417-11	CARBON	1K	5%	1/4W
R227	1-249-429-11	CARBON	10K	5%	1/4W
R501	1-249-405-11	CARBON	100	5%	1/4W
R502	1-249-405-11	CARBON	100	5%	1/4W
R503	1-249-434-11	CARBON	27K	5%	1/4W
R504	1-249-429-11	CARBON	10K	5%	1/4W
R505	1-249-413-11	CARBON	470	5%	1/4W
R506	1-247-864-11	CARBON	24K	5%	1/4W
R507	1-247-887-00	CARBON	220K	5%	1/4W
R510	1-249-429-11	CARBON	10K	5%	1/4W
R511	1-249-429-11	CARBON	10K	5%	1/4W
R512	1-247-887-00	CARBON	220K	5%	1/4W
R513	1-249-429-11	CARBON	10K	5%	1/4W
R514	1-249-441-11	CARBON	100K	5%	1/4W
R515	1-249-428-11	CARBON	8.2K	5%	1/4W
R516	1-249-423-11	CARBON	3.3K	5%	1/4W
R517	1-249-441-11	CARBON	100K	5%	1/4W
R518	1-249-417-11	CARBON	1K	5%	1/4W
R519	1-249-441-11	CARBON	100K	5%	1/4W
R520	1-249-429-11	CARBON	10K	5%	1/4W
R521	1-249-441-11	CARBON	100K	5%	1/4W
R522	1-249-433-11	CARBON	22K	5%	1/4W
R524	1-249-417-11	CARBON	1K	5%	1/4W
R526	1-249-429-11	CARBON	10K	5%	1/4W
R527	1-249-417-11	CARBON	1K	5%	1/4W
R528	1-249-437-11	CARBON	47K	5%	1/4W
R534	1-247-882-11	CARBON	130K	5%	1/4W
R535	1-249-440-11	CARBON	82K	5%	1/4W
R536	1-249-405-11	CARBON	100	5%	1/4W
R537	1-249-433-11	CARBON	22K	5%	1/4W
R538	1-249-425-11	CARBON	4.7K	5%	1/4W
R539	1-249-414-11	CARBON	560	5%	1/4W
R540	1-249-433-11	CARBON	22K	5%	1/4W
R541	1-249-407-11	CARBON	150	5%	1/4W
R543	1-249-433-11	CARBON	22K	5%	1/4W
R601	1-247-858-11	CARBON	13K	5%	1/4W
R602	1-247-844-11	CARBON	3.6K	5%	1/4W
R603	1-249-417-11	CARBON	1K	5%	1/4W
R604	1-247-862-11	CARBON	20K	5%	1/4W
R605	1-249-429-11	CARBON	10K	5%	1/4W
R701	1-249-413-11	CARBON	470	5%	1/4W

Ref. No.	Part No.	Description	Remark		
R702	1-249-413-11	CARBON	470	5%	1/4W
R703	1-249-422-11	CARBON	2.7K	5%	1/4W
R704	1-247-858-11	CARBON	13K	5%	1/4W
R705	1-249-429-11	CARBON	10K	5%	1/4W
R706	1-249-417-11	CARBON	1K	5%	1/4W
R707	1-247-850-11	CARBON	6.2K	5%	1/4W
R708	1-249-422-11	CARBON	2.7K	5%	1/4W
R709	1-249-429-11	CARBON	10K	5%	1/4W
R710	1-249-429-11	CARBON	10K	5%	1/4W
R711	1-249-421-11	CARBON	2.2K	5%	1/4W
R712	1-249-432-11	CARBON	18K	5%	1/4W
R713	1-249-423-11	CARBON	3.3K	5%	1/4W
R714	1-249-433-11	CARBON	22K	5%	1/4W
R715	1-249-435-11	CARBON	33K	5%	1/4W
R801	1-249-429-11	CARBON	10K	5%	1/4W
R802	1-247-903-00	CARBON	1M	5%	1/4W
R803	1-249-434-11	CARBON	27K	5%	1/4W
R804	1-249-434-11	CARBON	27K	5%	1/4W
R805	1-249-435-11	CARBON	33K	5%	1/4W
R806	1-249-435-11	CARBON	33K	5%	1/4W
R807	1-249-434-11	CARBON	27K	5%	1/4W
R808	1-247-895-00	CARBON	470K	5%	1/4W
R809	1-247-895-00	CARBON	470K	5%	1/4W
R810	1-249-434-11	CARBON	27K	5%	1/4W
R811	1-249-435-11	CARBON	33K	5%	1/4W
R812	1-249-435-11	CARBON	33K	5%	1/4W
R813	1-249-421-11	CARBON	2.2K	5%	1/4W
R814	1-249-421-11	CARBON	2.2K	5%	1/4W
R815	1-249-421-11	CARBON	2.2K	5%	1/4W
R816	1-249-421-11	CARBON	2.2K	5%	1/4W
R817	1-249-393-11	CARBON	10	5%	1/4W
R818	1-249-435-11	CARBON	33K	5%	1/4W
R821	1-247-903-00	CARBON	1M	5%	1/4W
R822	1-249-435-11	CARBON	33K	5%	1/4W
R823	1-249-425-11	CARBON	4.7K	5%	1/4W
R824	1-249-435-11	CARBON	33K	5%	1/4W
R825	1-249-429-11	CARBON	10K	5%	1/4W
R826	1-249-420-11	CARBON	1.8K	5%	1/4W
R827	1-249-435-11	CARBON	33K	5%	1/4W
R828	1-249-433-11	CARBON	22K	5%	1/4W
R829	1-249-433-11	CARBON	22K	5%	1/4W
R830	1-249-433-11	CARBON	22K	5%	1/4W
R831	1-249-421-11	CARBON	2.2K	5%	1/4W
R834	1-249-425-11	CARBON	4.7K	5%	1/4W
R835	1-249-435-11	CARBON	33K	5%	1/4W
R836	1-249-435-11	CARBON	33K	5%	1/4W
R837	1-249-433-11	CARBON	22K	5%	1/4W
R838	1-249-422-11	CARBON	2.7K	5%	1/4W

MAIN

MD-A

MD-B

Ref. No.	Part No.	Description	Remark		
R839	1-249-405-11	CARBON	100	5%	1/4W
R842	1-249-425-11	CARBON	4.7K	5%	1/4W
R843	1-247-862-11	CARBON	20K	5%	1/4W
R844	1-247-862-11	CARBON	20K	5%	1/4W
R845	1-249-425-11	CARBON	4.7K	5%	1/4W
R846	1-249-415-11	CARBON	680	5%	1/4W
R847	1-249-429-11	CARBON	10K	5%	1/4W
R848	1-249-415-11	CARBON	680	5%	1/4W
R849	1-249-429-11	CARBON	10K	5%	1/4W
R851	1-249-437-11	CARBON	47K	5%	1/4W
R852	1-247-866-11	CARBON	30K	5%	1/4W
R853	1-247-866-11	CARBON	30K	5%	1/4W
R854	1-249-437-11	CARBON	47K	5%	1/4W
R855	1-247-872-11	CARBON	51K	5%	1/4W
R856	1-247-872-11	CARBON	51K	5%	1/4W
R857	1-247-872-11	CARBON	51K	5%	1/4W
R858	1-247-872-11	CARBON	51K	5%	1/4W
R859	1-249-405-11	CARBON	100	5%	1/4W
R860	1-249-405-11	CARBON	100	5%	1/4W
R870	1-247-688-11	CARBON	2.2	5%	1/4W
R871	1-247-688-11	CARBON	2.2	5%	1/4W
< VARIABLE RESISTOR >					
RV101	1-238-600-11	RES. ADJ. CARBON 10K			
RV201	1-238-600-11	RES. ADJ. CARBON 10K			
< VIBRATOR >					
X801	1-577-358-21	VIBRATOR, CERAMIC (4MHz)			
X802	1-577-358-21	VIBRATOR, CERAMIC (4MHz)			

*	A-2006-399-A	MD-A BOARD, COMPLETE			

< CAPACITOR >					
C11	1-163-131-00	CERAMIC CHIP	390PF	5%	50V
C12	1-136-157-00	FILM	0.022uF	5%	50V
C13	1-124-234-00	ELECT	22uF	20%	16V
C18	1-163-117-00	CERAMIC CHIP	100PF	5%	50V
C21	1-163-131-00	CERAMIC CHIP	390PF	5%	50V
C22	1-136-157-00	FILM	0.022uF	5%	50V
C23	1-124-234-00	ELECT	22uF	20%	16V
C28	1-163-117-00	CERAMIC CHIP	100PF	5%	50V
C31	1-124-234-00	ELECT	22uF	20%	16V
C32	1-124-234-00	ELECT	22uF	20%	16V
C72	1-124-499-11	ELECT, NONPOLAR	1uF	20%	50V

Ref. No.	Part No.	Description	Remark		
< CONNECTOR >					
* CNJ72	1-580-411-11	SOCKET, CONNECTOR 4P			
* CNP32	1-580-772-11	PIN, CONNECTOR (PC BOARD) 4P			
* CNP71	1-564-719-11	PIN, CONNECTOR (SMALL TYPE) 3P			
< IC >					
IC31	8-759-106-02	IC uPC4570G2			
< JUMPER >					
JW1	1-216-295-00	METAL CHIP	0	5%	1/10W
JW51	1-216-296-00	METAL CHIP	0	5%	1/8W
JW52	1-216-296-00	METAL CHIP	0	5%	1/8W
JW53	1-216-296-00	METAL CHIP	0	5%	1/8W
JW54	1-216-296-00	METAL CHIP	0	5%	1/8W
< TRANSISTOR >					
Q71	8-729-602-36	TRANSISTOR 2SA1602			
< RESISTOR >					
R11	1-216-099-00	METAL CHIP	120K	5%	1/10W
R12	1-216-025-00	METAL CHIP	100	5%	1/10W
R13	1-216-100-00	METAL GLAZE	130K	5%	1/10W
R14	1-216-067-00	METAL CHIP	5.6K	5%	1/10W
R21	1-216-099-00	METAL CHIP	120K	5%	1/10W
R22	1-216-025-00	METAL CHIP	100	5%	1/10W
R23	1-216-100-00	METAL GLAZE	130K	5%	1/10W
R24	1-216-067-00	METAL CHIP	5.6K	5%	1/10W
R31	1-216-033-00	METAL CHIP	220	5%	1/10W
R32	1-216-033-00	METAL CHIP	220	5%	1/10W
R71	1-216-082-00	METAL GLAZE	24K	5%	1/10W
R72	1-216-081-00	METAL CHIP	22K	5%	1/10W
R73	1-216-089-00	METAL CHIP	47K	5%	1/10W
R74	1-216-089-00	METAL CHIP	47K	5%	1/10W
< VARIABLE RESISTOR >					
RV11	1-238-012-11	RES. ADJ. CARBON 1K			
RV21	1-238-012-11	RES. ADJ. CARBON 1K			
RV71	1-238-016-11	RES. ADJ. CARBON 10K			
RV72	1-238-016-11	RES. ADJ. CARBON 10K			

*	A-2006-400-A	MD-B BOARD, COMPLETE			

< CAPACITOR >					
C11	1-163-131-00	CERAMIC CHIP	390PF	5%	50V
C12	1-136-157-00	FILM	0.022uF	5%	50V
C13	1-124-234-00	ELECT	22uF	20%	16V
C14	1-136-273-91	FILM	75PF	5%	630V

MD-B

Ref. No.	Part No.	Description			Remark
C15	1-164-080-11	CERAMIC	390PF	10%	50V
C17	1-163-103-00	CERAMIC CHIP	27PF	5%	50V
C18	1-163-117-00	CERAMIC CHIP	100PF	5%	50V
C21	1-163-131-00	CERAMIC CHIP	390PF	5%	50V
C22	1-136-157-00	FILM	0.022uF	5%	50V
C23	1-124-234-00	ELECT	22uF	20%	16V
C24	1-136-273-91	FILM	75PF	5%	630V
C25	1-164-080-11	CERAMIC	390PF	10%	50V
C27	1-163-103-00	CERAMIC CHIP	27PF	5%	50V
C28	1-163-117-00	CERAMIC CHIP	100PF	5%	50V
C31	1-124-234-00	ELECT	22uF	20%	16V
C32	1-124-234-00	ELECT	22uF	20%	16V
C33	1-124-234-00	ELECT	22uF	20%	16V
C51	1-163-019-00	CERAMIC CHIP	0.0068uF	10%	50V
C52	1-163-019-00	CERAMIC CHIP	0.0068uF	10%	50V
C53	1-163-022-00	CERAMIC CHIP	0.012uF	10%	50V
C54	1-136-559-11	FILM	0.0047uF	5%	630V
C56	1-164-505-11	CERAMIC CHIP	2.2uF		16V
C57	1-164-346-11	CERAMIC CHIP	1uF		16V
C58	1-163-024-00	CERAMIC CHIP	0.018uF	10%	50V
C72	1-124-499-11	ELECT. NONPOLAR	1uF	20%	50V
< CONNECTOR >					
* CNJ31	1-580-782-11	CONNECTOR, BOARD TO BOARD			
* CNJ33	1-580-782-11	CONNECTOR, BOARD TO BOARD			
* CNJ72	1-580-411-11	SOCKET, CONNECTOR 4P			
* CNP32	1-580-781-11	PIN, CONNECTOR (PC BOARD) 7P			
* CNP71	1-564-719-11	PIN, CONNECTOR (SMALL TYPE) 3P			
< DIODE >					
D31	8-719-988-62	DIODE 1SS355			
< IC >					
IC31	8-759-106-02	IC uPC4570G2			
< JUMPER >					
JW1	1-216-296-00	METAL CHIP	0	5%	1/8W
JW2	1-216-295-00	METAL CHIP	0	5%	1/10W
JW3	1-216-295-00	METAL CHIP	0	5%	1/10W
JW4	1-216-295-00	METAL CHIP	0	5%	1/10W
JW5	1-216-295-00	METAL CHIP	0	5%	1/10W
JW6	1-216-295-00	METAL CHIP	0	5%	1/10W
JW7	1-216-295-00	METAL CHIP	0	5%	1/10W
JW52	1-216-296-00	METAL CHIP	0	5%	1/8W
JW53	1-216-296-00	METAL CHIP	0	5%	1/8W
JW54	1-216-296-00	METAL CHIP	0	5%	1/8W
JW55	1-216-296-00	METAL CHIP	0	5%	1/8W
JW56	1-216-296-00	METAL CHIP	0	5%	1/8W

Ref. No.	Part No.	Description			Remark
JW57	1-216-296-00	METAL CHIP	0	5%	1/8W
JW58	1-216-296-00	METAL CHIP	0	5%	1/8W
JW59	1-216-296-00	METAL CHIP	0	5%	1/8W
JW60	1-216-296-00	METAL CHIP	0	5%	1/8W
JW61	1-216-296-00	METAL CHIP	0	5%	1/8W
< COIL >					
L11	1-410-780-11	INDUCTOR			27mH
L21	1-410-780-11	INDUCTOR			27mH
< TRANSISTOR >					
Q51	8-729-808-01	TRANSISTOR	2SD1622-S		
Q52	8-729-808-01	TRANSISTOR	2SD1622-S		
Q53	8-729-808-01	TRANSISTOR	2SD1622-S		
Q71	8-729-602-36	TRANSISTOR	2SA1602		
< RESISTOR >					
R11	1-216-099-00	METAL CHIP	120K	5%	1/10W
R12	1-216-025-00	METAL CHIP	100	5%	1/10W
R13	1-216-100-00	METAL GLAZE	130K	5%	1/10W
R14	1-216-067-00	METAL CHIP	5.6K	5%	1/10W
R15	1-249-430-11	CARBON	12K	5%	1/4W
R21	1-216-099-00	METAL CHIP	120K	5%	1/10W
R22	1-216-025-00	METAL CHIP	100	5%	1/10W
R23	1-216-100-00	METAL GLAZE	130K	5%	1/10W
R24	1-216-067-00	METAL CHIP	5.6K	5%	1/10W
R25	1-249-430-11	CARBON	12K	5%	1/4W
R31	1-216-033-00	METAL CHIP	220	5%	1/10W
R32	1-216-033-00	METAL CHIP	220	5%	1/10W
R41	1-249-393-11	CARBON	10	5%	1/4W
R42	1-249-393-11	CARBON	10	5%	1/4W
R51	1-216-075-00	METAL CHIP	12K	5%	1/10W
R52	1-216-075-00	METAL CHIP	12K	5%	1/10W
R53	1-216-073-00	METAL CHIP	10K	5%	1/10W
R54	1-216-309-00	METAL CHIP	5.6	5%	1/10W
R55	1-216-309-00	METAL CHIP	5.6	5%	1/10W
R56	1-216-298-00	METAL CHIP	2.2	5%	1/10W
R71	1-216-082-00	METAL GLAZE	24K	5%	1/10W
R72	1-216-081-00	METAL CHIP	22K	5%	1/10W
R73	1-216-089-00	METAL CHIP	47K	5%	1/10W
R74	1-216-089-00	METAL CHIP	47K	5%	1/10W
< VARIABLE RESISTOR >					
RV11	1-238-012-11	RES. ADJ. CARBON	1K		
RV12	1-238-551-11	RES. ADJ. CARBON	220K		
RV21	1-238-012-11	RES. ADJ. CARBON	1K		
RV22	1-238-551-11	RES. ADJ. CARBON	220K		
RV71	1-238-016-11	RES. ADJ. CARBON	10K		

MD-B **PANEL** **RECVOL**

Ref.No.	Part No.	Description	Remark
RV72	1-238-016-11	RES. ADJ. CARBON 10K	
		< RELAY >	
RY31	1-515-726-11	RELAY	
		< COIL >	
T51	1-406-419-11	COIL, BIAS OSCILLATION	

*	A-2006-747-A	PANEL BOARD, COMPLETE	

*	3-362-478-21	HOLDER (T), LED	
*	4-921-941-01	CUSHION (FL)	
*	4-933-646-01	HOLDER (TC), FL TUBE	
		< CAPACITOR >	
C406	1-162-292-31	CERAMIC 680PF 10% 50V	
C407	1-162-292-31	CERAMIC 680PF 10% 50V	
C408	1-162-292-31	CERAMIC 680PF 10% 50V	
C901	1-161-379-00	CERAMIC 0.01uF 20% 25V	
C902	1-161-379-00	CERAMIC 0.01uF 20% 25V	
		< CONNECTOR >	
* CN901	1-568-836-11	SOCKET, CONNECTOR 17P	
		< DIODE >	
D901	8-719-301-38	LED SEL2210S-C	
D902	8-719-301-38	LED SEL2210S-C	
D903	8-719-301-38	LED SEL2210S-C	
D904	8-719-301-38	LED SEL2210S-C	
D906	8-719-987-63	DIODE 1N4148M	
		< FLUORESCENT INDICATOR >	
FL901	1-519-741-11	INDICATOR TUBE, FLUORESCENT	
		< IC >	
IC901	8-759-321-92	IC HD614022S	
		< TRANSISTOR >	
Q901	8-729-900-61	TRANSISTOR DTA114ES	
		< RESISTOR >	
R401	1-249-405-11	CARBON 100 5% 1/4W	
R402	1-249-405-11	CARBON 100 5% 1/4W	
R403	1-249-405-11	CARBON 100 5% 1/4W	
R901	1-249-407-11	CARBON 150 5% 1/4W	
R902	1-249-409-11	CARBON 220 5% 1/4W	

Ref.No.	Part No.	Description	Remark
R904	1-249-413-11	CARBON 470 5% 1/4W	
R905	1-249-415-11	CARBON 680 5% 1/4W	
R906	1-249-417-11	CARBON 1K 5% 1/4W	
R907	1-249-420-11	CARBON 1.8K 5% 1/4W	
R909	1-249-407-11	CARBON 150 5% 1/4W	
R910	1-249-409-11	CARBON 220 5% 1/4W	
R911	1-249-411-11	CARBON 330 5% 1/4W	
R912	1-249-418-11	CARBON 1.2K 5% 1/4W	
R927	1-249-411-11	CARBON 330 5% 1/4W	
R928	1-249-411-11	CARBON 330 5% 1/4W	
R929	1-249-411-11	CARBON 330 5% 1/4W	
R930	1-249-411-11	CARBON 330 5% 1/4W	
R931	1-247-903-00	CARBON 1M 5% 1/4W	
R932	1-249-411-11	CARBON 330 5% 1/4W	
		< SWITCH >	
S901	1-554-303-21	SWITCH, TACTILE (HIGH SPEED)	
S902	1-554-303-21	SWITCH, TACTILE (NORMAL SPEED)	
S905	1-554-303-21	SWITCH, TACTILE (RESET)	
S906	1-554-303-21	SWITCH, TACTILE (MEMORY)	
S907	1-554-303-21	SWITCH, TACTILE (A/B)	
S909	1-554-303-21	SWITCH, TACTILE (C FADE)	
S910	1-554-303-21	SWITCH, TACTILE (FADE)	
S911	1-554-303-21	SWITCH, TACTILE (EDIT)	
S912	1-554-303-21	SWITCH, TACTILE (TIME)	
		< VIBRATOR >	
X901	1-567-775-11	VIBRATOR, CERAMIC (4.19MHZ)	

*	1-643-528-11	RECVOL BOARD	

		< CAPACITOR >	
C814	1-164-159-11	CERAMIC 0.1uF 50V	
		< CONNECTOR >	
* CN508	1-568-832-11	SOCKET, CONNECTOR 13P	
		< DIODE >	
D805	8-719-987-63	DIODE 1N4148M	
D806	8-719-987-63	DIODE 1N4148M	
		< IC >	
IC806	8-759-820-62	IC LB1639	
		< TRANSISTOR >	
Q807	8-729-900-65	TRANSISTOR DTA144ES	

RECVOL

SW-A

SW-B

Ref. No.	Part No.	Description	Remark
Q808	8-729-900-89	TRANSISTOR DTC144ES	
< RESISTOR >			
R125	1-249-429-11	CARBON 10K 5% 1/4W	
R225	1-249-429-11	CARBON 10K 5% 1/4W	
R832	1-249-412-11	CARBON 390 5% 1/4W	
R833	1-249-411-11	CARBON 330 5% 1/4W	
< VARIABLE RESISTOR >			
RV301	1-241-891-11	RES. VAR. CARBON 20KX3 (REC LEVEL)	

*	1-634-841-14	SW-A BOARD	

	3-343-419-01	HOLDER (S SENSER A)	
< CONNECTOR >			
* CNP81	1-568-852-11	SOCKET, CONNECTOR 9P	
< IC >			
IC81	8-719-710-03	DIODE NJL5165K-B	
< RESISTOR >			
R84	1-249-417-11	CARBON 1K 5% 1/4W	
R85	1-249-408-11	CARBON 180 5% 1/4W	
< SWITCH >			
S81	1-571-958-11	SWITCH, PUSH (1 KEY) (STOP)	
S82	1-571-281-21	SWITCH, LEAF (70EQ)	
S86	1-571-281-21	SWITCH, LEAF (HALF)	

*	1-634-841-14	SW-B BOARD	

	3-343-419-01	HOLDER (S SENSER A)	
< CONNECTOR >			
* CNP81	1-568-852-11	SOCKET, CONNECTOR 9P	
< IC >			
IC81	8-719-710-03	DIODE NJL5165K-B	
< RESISTOR >			
R81	1-249-414-11	CARBON 560 5% 1/4W	
R82	1-247-818-11	CARBON 300 5% 1/4W	
R83	1-247-834-11	CARBON 1.3K 5% 1/4W	
R84	1-249-417-11	CARBON 1K 5% 1/4W	

Ref. No.	Part No.	Description	Remark
R85	1-249-408-11	CARBON 180 5% 1/4W	
< SWITCH >			
S81	1-571-958-11	SWITCH, PUSH (1 KEY) (STOP)	
S82	1-571-281-21	SWITCH, LEAF (70EQ)	
S83	1-571-281-21	SWITCH, LEAF (METAL)	
S84	1-571-281-21	SWITCH, LEAF (REC A)	
S85	1-571-281-21	SWITCH, LEAF (REC B)	
S86	1-571-281-21	SWITCH, LEAF (HALF)	

MISCELLANEOUS			

* 5	1-574-726-11	WIRE, FLAT TYPE (13 CORE)	
6	1-690-907-11	WIRE (FLAT TYPE) (17 CORE)	
69	1-690-906-11	WIRE (FLAT TYPE) (9 CORE)	
121	1-638-983-11	MOTOR FLEXIBLE BOARD	
HP901	A-2003-837-A	BASE ASSY, HEAD (PB) (DECK A)	
HRPE901A	2003-838-A	BASE ASSY, HEAD (REC/PB/ERASE) (DECK B)	
M901A	X-3359-417-1	MOTOR ASSY (CAPSTAN) (DECK A)	
M901B	X-3359-417-1	MOTOR ASSY (CAPSTAN) (DECK B)	
M902A	X-3363-501-1	MOTOR ASSY (REEL) (DECK A)	
M902B	X-3363-501-1	MOTOR ASSY (REEL) (DECK B)	

ACCESSORIES & PACKING MATERIALS			

*	3-350-154-01	CUSHION	
	4-920-940-01	SHEET (A), PROTECTION	

HARDWARE LIST

#1	7-685-646-79	SCREW +BVTP 3X8 TYPE2 N-S
#2	7-621-773-93	SCREW (PANEL 2.6 TP2)
#3	7-685-645-79	SCREW +BVTP 3X6 TYPE2 N-S
#4	7-621-775-00	SCREW +B 2.6X3
#5	7-627-556-08	SCREW +P 2.6X2.8

TC-D607

SONY[®] SERVICE MANUAL

AEP Model
UK Model
E Model
Australian Model

SUPPLEMENT-1

File this supplement with the service manual.

Subject : Addition of R798 and R799 to UK model.

 : Added portion

5-3. PRINTED WIRING BOARDS –MAIN section–

[MAIN BOARD]

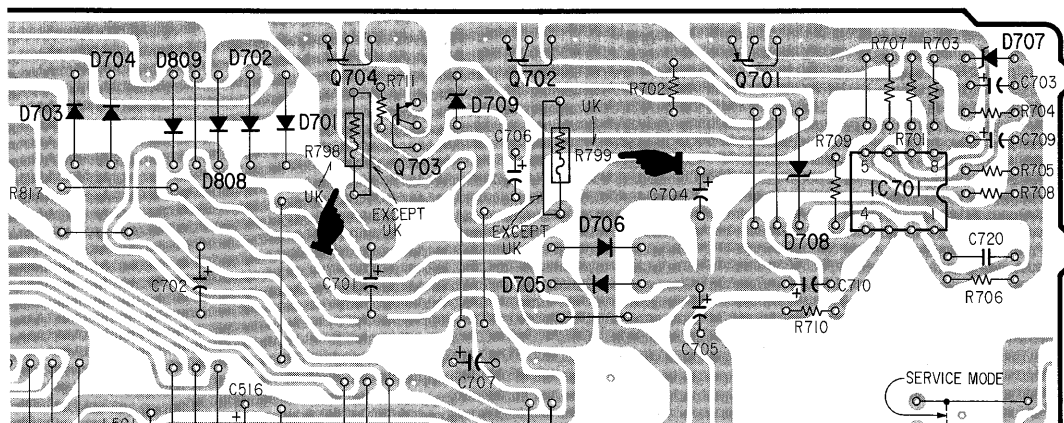

5-4. SCHEMATIC DIAGRAMS –MAIN section–

[MAIN BOARD]

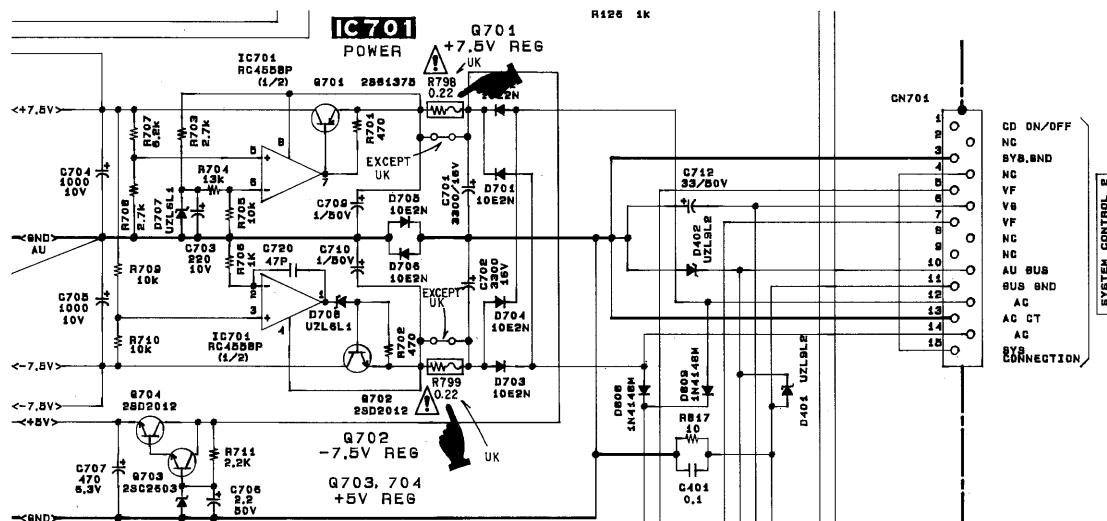

SECTION 7. ELECTRICAL PARTS LIST

Ref.No.	Part No.	Description	Remark
△R798	1-219-136-11	RES, FUSE 0.22 10% 1/4W	
△R799	1-219-136-11	RES, FUSE 0.22 10% 1/4W	

The components identified by mark Δ or dotted line with mark Δ are critical for safety. Replace only with part number specified.

TC-D607

SONY SERVICE MANUAL

AEP Model
UK Model
E model
Australian Model

CORRECTION-1

Correct your service manual as shown below.

___ (Under line) : indicates corrected portion.

Page	INCORRECT			CORRECT		
	<u>Ref. No.</u>	<u>Part No.</u>	<u>Description</u>	<u>Ref. No.</u>	<u>Part No.</u>	<u>Description</u>
28	151	X-3363-790-1	CHASSIS ASSY, MECHANICAL (DECK A)	151	<u>X-3359-415-1</u>	CHASSIS ASSY, MECHANICAL (DECK A)

(SPM-95045)