

TC-D707

SERVICE MANUAL

*AEP Model
UK Model
E Model
Australian Model*



• This set is the cassette deck section in LBT-D707CD/D707CDM.

Model Name Using Similar Mechanism		TC-H1600/WR590
Tape Transport Mechanism Type	DECK A	TCM-190RA12C
	DECK B	TCM-190RB12C

SPECIFICATIONS

Recording system	4-track 2-channel stereo
Frequency response	DOLBY NR OFF With Type IV cassette (Sony METAL-ES) 30 Hz to 15 kHz (± 3 dB) With Type II cassette (Sony UX-S) 40 Hz to 14 kHz (± 3 dB) With Type I cassette (Sony HF-S) 40 Hz to 14 kHz (± 3 dB)
Wow and flutter	$\pm 0.2\%$ W.PEAK (DIN)
Weight	Approx. 3.5 kg (8 lb 1 oz)
Dimensions	Approx. 355 x 131 x 304 mm (14 x 5 $\frac{1}{4}$ x 12 inches) (w/h/d, including projections)

Design and specifications are subject to change without notice.

Note

This appliance conforms with EEC Directive 87/308/EEC regarding interference suppression.

Dolby noise reduction and HX Pro headroom extension manufactured under license from Dolby Laboratories Licensing Corporation. HX Pro originated by Bang & Olufsen.



"DOLBY", the double-D symbol  and "HX PRO" are trademarks of Dolby Laboratories Licensing Corporation.

STEREO CASSETTE DECK
SONY[®]

TABLE OF CONTENTS

<u>Section</u>	<u>Title</u>	<u>Page</u>
SECTION 1.	GENERAL	3
SECTION 2.	DISASSEMBLY	4
SECTION 3.	ADJUSTMENTS	
	3-1. Mechanical Adjustments	6
	3-2. Electrical Adjustments	6
SECTION 4.	DIAGRAMS	
	4-1. Circuit Boards Location	10
	4-2. Semiconductor Lead Layouts	11
	4-3. Printed Wiring Boards—Main Section—	12
	4-4. Schematic Diagrams—Main Section—	17
	IC Block Diagrams	21
	4-5. Printed Wiring Boards—Panel Section—	21
	4-6. Schematic Diagrams—Panel Section—	23
SECTION 5.	EXPLODED VIEWS	
	5-1. Overall Section	25
	5-2. Front panel Section	26
	5-3. Mechanism Section-1	27
	5-4. Mechanism Section-2	28
SECTION 6.	ELECTRICAL PARTS LIST	29

SAFETY-RELATED COMPONENT WARNING!!

COMPONENTS IDENTIFIED BY MARK  OR DOTTED LINE WITH MARK  ON THE SCHEMATIC DIAGRAMS AND IN THE PARTS LIST ARE CRITICAL TO SAFE OPERATION. REPLACE THESE COMPONENTS WITH SONY PARTS WHOSE PART NUMBERS APPEAR AS SHOWN IN THIS MANUAL OR IN SUPPLEMENTS PUBLISHED BY SONY.

SECTION 1 GENERAL

This section is extracted
from instruction manual.

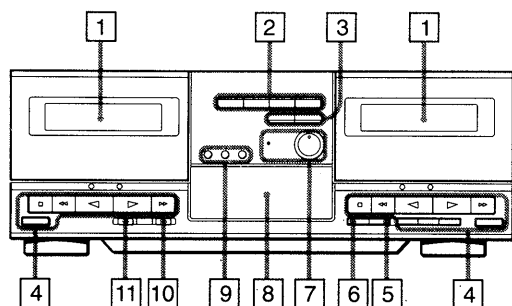

- 1 Cassette holders
- 2 AUTO CD SYNCHRO REC buttons and indicators
C.(Cross) FADE (29)
FADE (28)
EDIT (31)
TIME (31)
- 3 SYNCHRO DUBBING buttons (24)
- 4 Tape operation buttons
◀◀ Leftward fast winding/AMS*, ▶▶ Rightward fast winding/AMS*, ▶ Forward play, ◀ Reverse play, ■ Stop, ▲ EJECT, || PAUSE (deck B only), ○ REC MUTE Record muting (deck B only), ● REC Record (deck B only)
- 5 FADER button (22)
- 6 ARL (Automatic recording level) button and indicator (21)
- 7 REC (recording) LEVEL control and indicator (20)
- 8 Display window
- 9 COUNTER setting buttons (19)
A/B, MEMORY and RESET button
- 10 DOLBY NR (noise reduction) selector (20)
- 11 DIRECTION MODE selector (17, 20, 24)

* AMS is the abbreviation of Automatic Music Sensor.

SECTION 2 DISASSEMBLY

NOTE: Follow the disassembly procedure in the numerical order given.

CASE

Unscrew the four case attachment screws M3×8 and remove the case.

FRONT PANEL

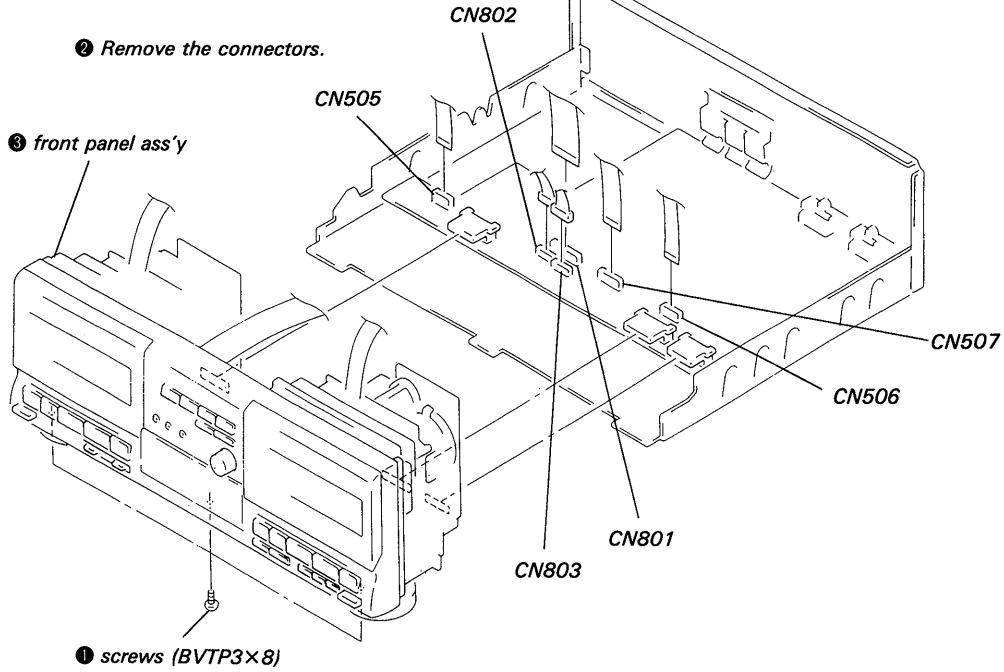

MECHANISM DECK

① Press the EJECT button.

② cassette lid

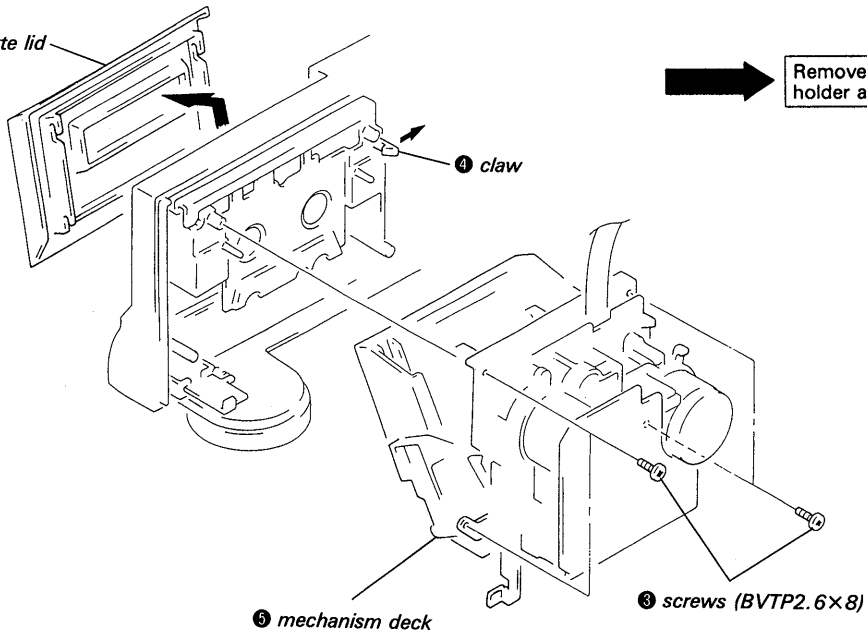

Remove the cassette holder assembly.

HEAD

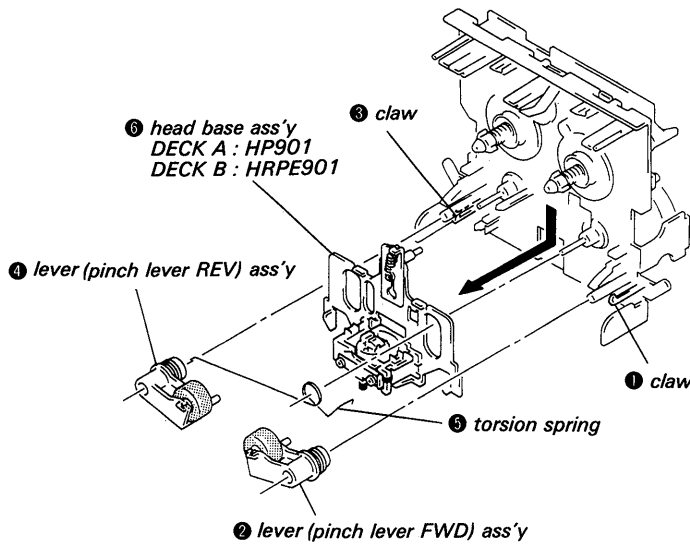

MOTOR

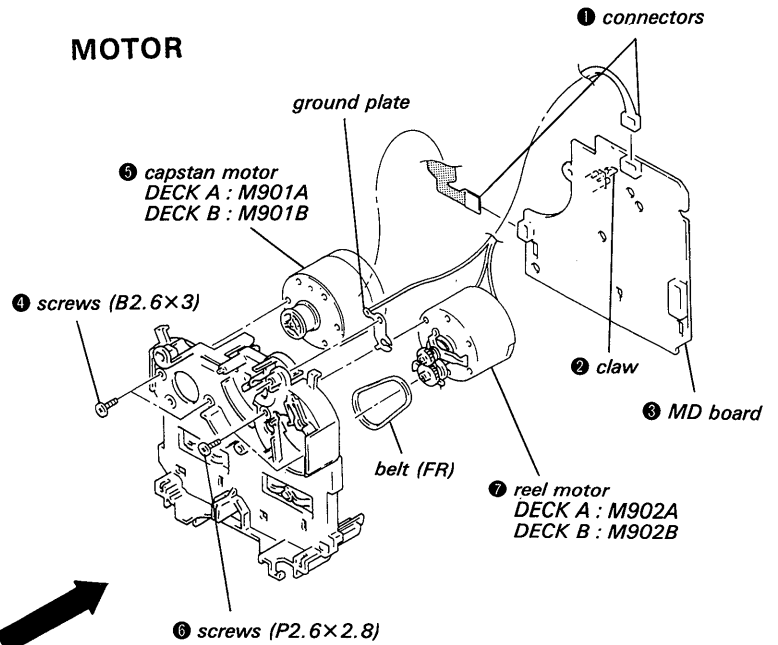

FITTING BASE BLOCK

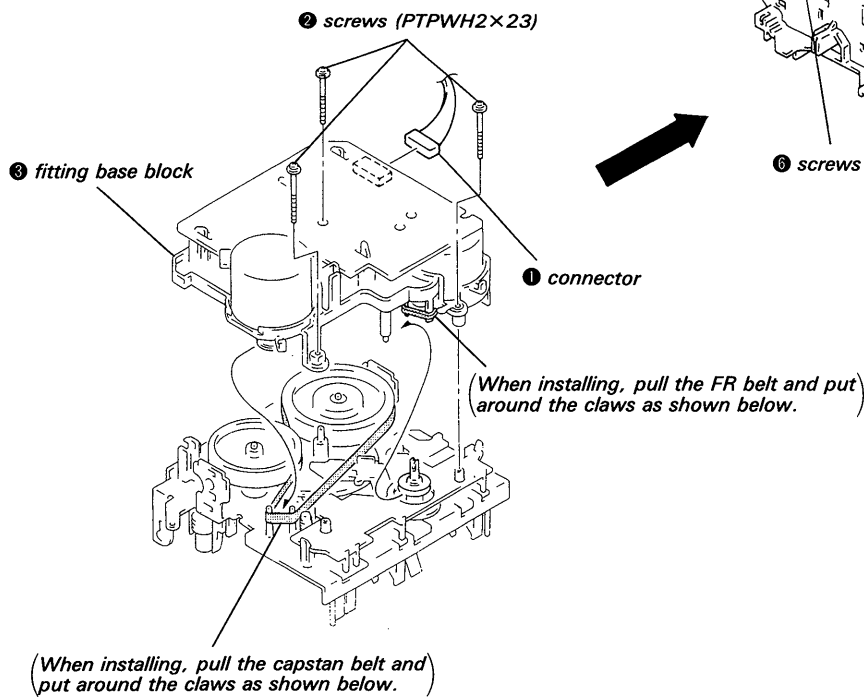

SECTION 3 ADJUSTMENTS

3-1. MECHANICAL ADJUSTMENTS

PRECAUTION

1. Clean the following parts with a denatured-alcoholmoistened swab;

record/playback/erase head	
pinch roller	rubber belts
capstan	idler
2. Demagnetize the record/playback head with a head demagnetizer.
(Head demagnetizer do not approach for the erase head.)
3. Do not use a magnetized screwdriver for the adjustments.
4. After the adjustments, apply suitable locking compound to the parts adjusted.
5. The adjustments should be performed in the rated power supply voltage unless otherwise noted.

Torque Measurement

Torque	Torque meter	Meter reading
FWD	CQ-102C	35 to 60g · cm (0.49 to 0.83 oz · inch)
FWD Back tension	CQ-102C	2 to 6g · cm (0.03 to 0.08 oz · inch)
REV	CQ-102RC	35 to 60g · cm (0.49 to 0.83 oz · inch)
REV Back tension	CQ-102RC	2 to 6g · cm (0.03 to 0.08 oz · inch)
FF, REW	CQ-201B	70 to 110g · cm (0.98 to 1.52 oz · inch)

3-2. ELECTRICAL ADJUSTMENTS

Note: The adjustment should be performed in the order given in the service manual. As a rule, adjustment about playback should be performed before adjustment about recording. The adjustments should be performed for both L-CH and R-CH.

● **Test Mode**

The Test mode is activated by shorting Test Point Service mode (IC805 34 pin changes over to "L") with the POWER switch in OFF position, then turning on the POWER switch.

In this mode, the following functions operate:

1. Source monitor
Line mute is cancelled during recording.
2. High speed playback
High speed playback is executed when the HIGH SPEED (DUBBING) button is pressed during playback. Normal speed playback is restored when the button is pressed again.
3. Record memory
The tape counter is reset to "0" at the record start point.
After adjustment, open the Service mode to cancel the Test mode.

[MAIN BOARD] (CONDUCTOR SIDE)

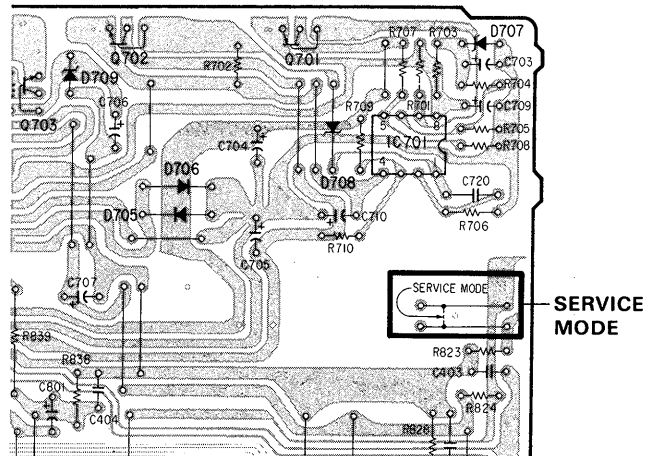

- Switches and controls should be set as follows unless otherwise specified.

NR switch : OFF
DIR MODE switch : ⇄

- Standard Record:
Deliver the standard input signal level to the input jack and set the REC LEVEL control to obtain the standard output signal level.

– Record Mode –

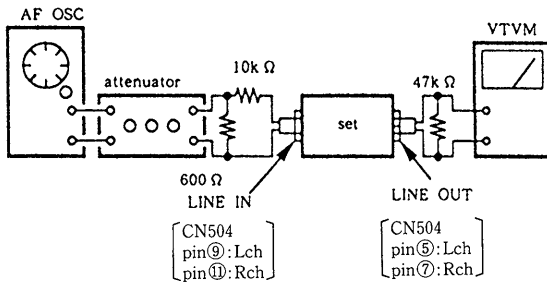

Standard Input Level

input terminal	LINE IN
source impedance	10kΩ
input level	0.25V (-10dB)

Standard Output Level

output terminal	LINE OUT
load impedance	47kΩ
output level	0.44V (-5dB)

Test tape

Type	Signal	Used for
P-4-A100	10kHz, -10dB	Azimuth Adjustment
P-4-L300	315Hz, 0dB	PB Level Adjustment
WS-48B	3kHz, 0dB	Tape Speed Adjustment

Record/Playback Head Azimuth Adjustment

DECK A DECK B

Procedure :

1. Mode: FWD playback

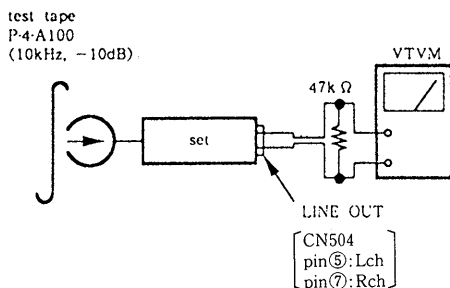

2. Turn the adjustment screw for the maximum output levels. If these levels do not match, turn the adjustment screw until both of output levels match together within 1dB.

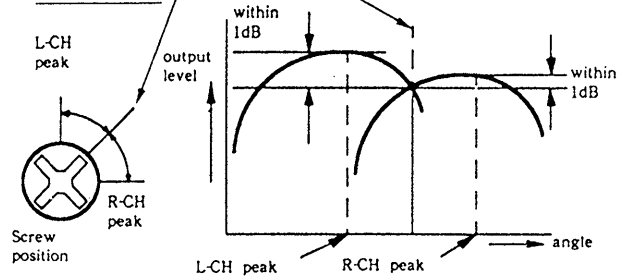

3. Phase Check
Mode: playback

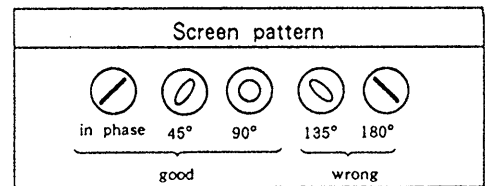
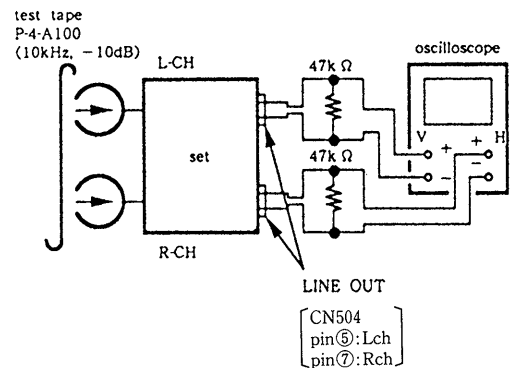

4. Set in the REV mode and repeat the step 1-3.
5. After the adjustment, lock the screws with locking compound.

Adjustment Location : Record/playback head

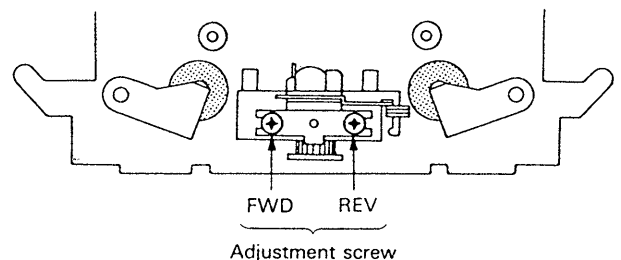

Tape Speed Adjustment **DECK A** **DECK B**

Procedure :

Mode: playback

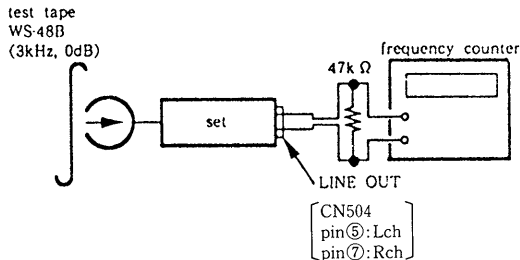

Perform high speed adjustment before normal speed adjustment.

(High speed adjustment)

1. Continue pressing the SYNCHRO DUBBING HIGH SPEED switch.
2. Check that frequency counter reading is within the standard value $6,000 \pm 60\text{Hz}$.
3. If out of the standard, adjust each RV72 so that the frequency counter reading satisfies $6,000 \pm 60\text{Hz}$ on both A and B decks.
4. Change over to Rev playback status, and repeat the above steps 1 to 3.

(Normal speed adjustment)

1. Continue pressing the SYNCHRO DUBBING NORM SPEED switch.
2. Check that the frequency counter reading is within the standard value $3,000 \pm 30\text{Hz}$.
3. If out of the standard, adjust each RV71 so that the frequency counter reading satisfies $3,000 \pm 30\text{Hz}$ on both A and B decks.
4. Change over to REV playback status, and repeat the above steps 1 to 3.

Frequency difference between the beginning and the end of the tape should be within 3%.

Frequency difference between deck A and deck B the beginning of the tape should be within 1.0%.

Adjustment Location :

MD-A, MD-HX board

Playback Level Adjustment

DECK A **DECK B**

Procedure :

Mode: playback

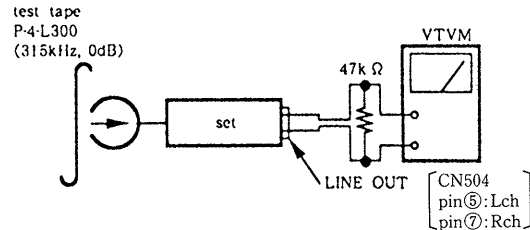

Adjust RV11 (L-CH), RV21 (R-CH) so that the reading on VTVM meets the adjustment limits below.

Adjustment Limits :

LINE OUT level: $-5 \pm 0.5\text{dB}$ (0.42–0.46V)

Level difference between channels: less than 0.5dB
Check that the LINE OUT level does not change in playback mode while changing the mode from playback to stop several times.

Adjustment Location : MD-A, MD-HX board

Bias Consumption Current Adjustment

This adjustment should be performed when replacing the head assy or the bias oscillating transformer (T81,T91).

Procedure :

() : R-CH

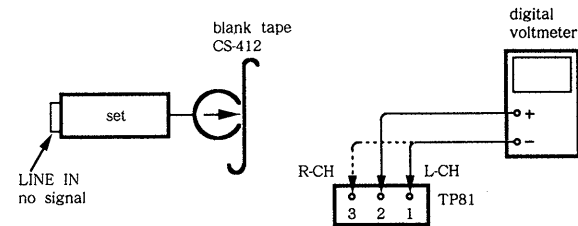

1. Connect the digital voltmeter to test point TP81.
2. Set RV81 (RV91) to mechanical center.
3. Set to FWD record mode.
4. Adjust T81 (T91) so that the digital voltmeter reading becomes minimum.

Adjustment Location : MD-HX board

Record Bias Adjustment **DECK B**

Setting :

REC LEVEL control : Standard Record (See page 7).

Procedure :

1. Mode : record

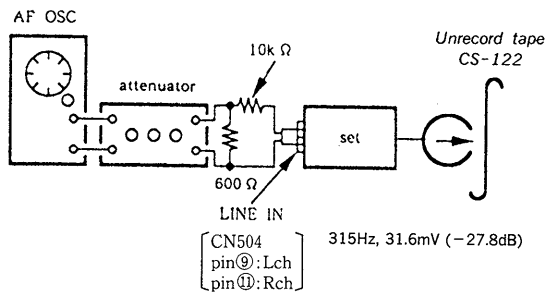

2. Mode : playback

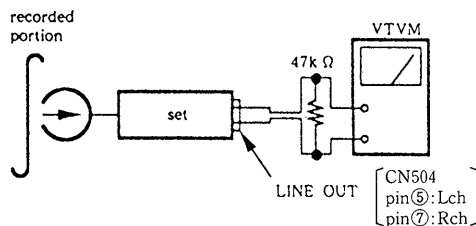

Playback the signal recorded in step 1.

Confirm that the 10kHz playback output is $0 \pm 0.5\text{dB}$ relative to the 315Hz output. If necessary, adjust RV 81 (L-CH), RV 91 (R-CH) and repeat the steps given above.

Adjustment Location : MD-HX board

Record Level Adjustment **DECK B**

Setting :

REC LEVEL control : Standard Record (See page 7).

Procedure :

1. Mode: record

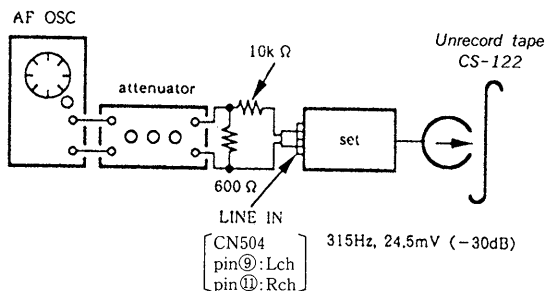

2. Mode: playback

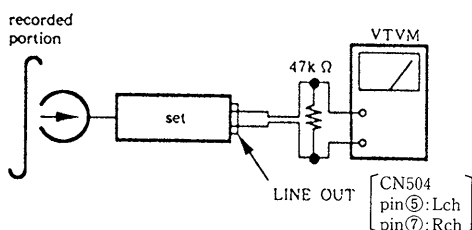

3. Playback the signal recorded in step 1.

Confirm that the signal level is within the adjustment limits below. If necessary, adjust RV101 (L-CH), RV201 (R-CH) and repeat the step 1-2.

Adjustment Limits : $-27.7\text{dB} \pm 0.5\text{dB}$ (30.2–33.8mV)

Adjustment Location : MAIN board (component side)

- Adjustment Parts Location Diagrams -

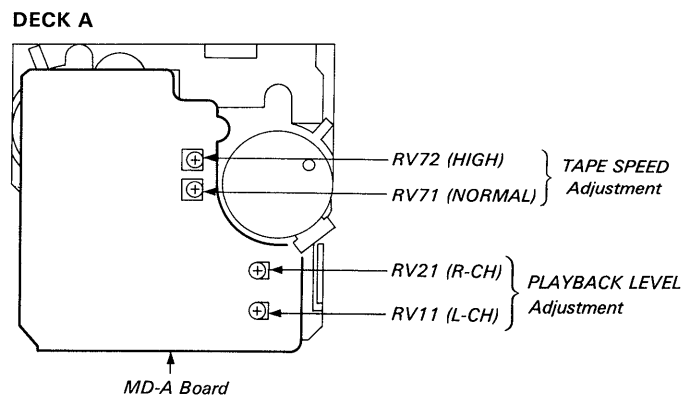
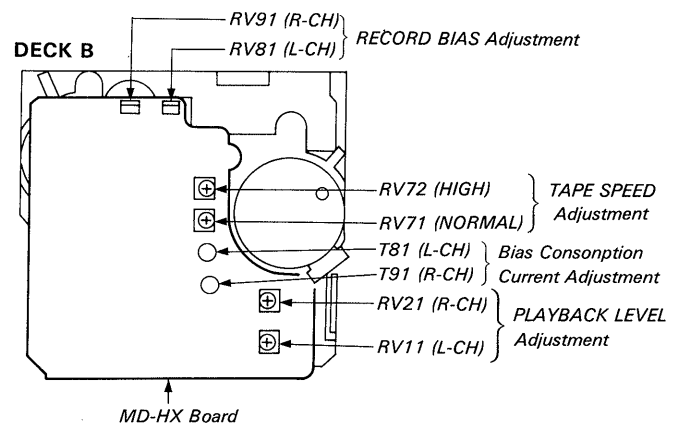

MAIN BOARD (COMPONENT SIDE)

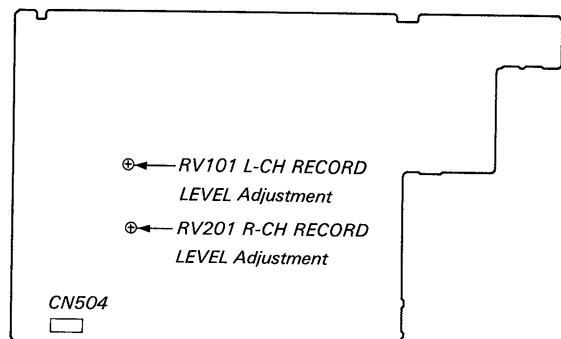

SECTION 4 DIAGRAMS

4-1. CIRCUIT BOARDS LOCATION

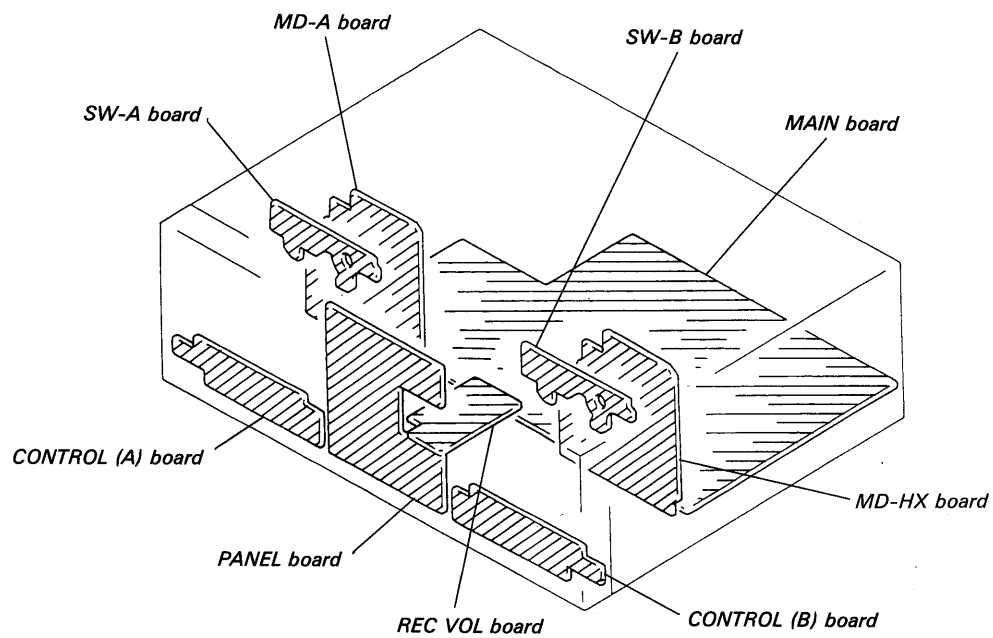

4-2. SEMICONDUCTOR LEAD LAYOUTS

TA7272P

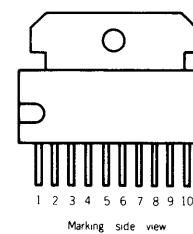

2SC2603-EF
2SC3622A-LK
DTA114ES
DTA144ES
DTC114ES
DTC143TS



NJL5165K-B

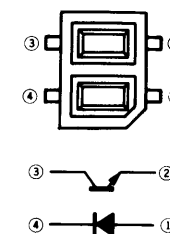

2SA1175-HFE
DTC144ES

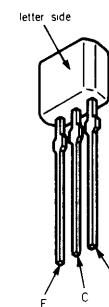

SEL2210S-C

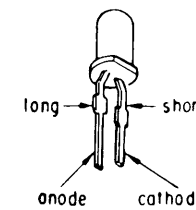

1N4148M
10E2N

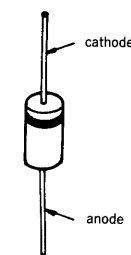

SEL2213C-C

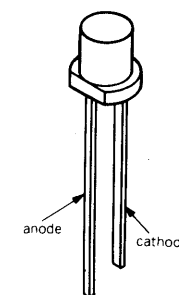

2SB1013-4



1SS352

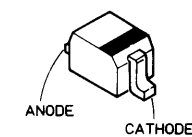

2SB1094-LK
2SD2012



HZS6A1L
HZS9A2L
UZL-7L2

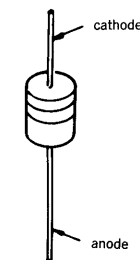

4-3. PRINTED WIRING BOARDS - MAIN Section -
• See page 10, 11 Circuit boards location and Semiconductor lead layouts.

● Semiconductor Location

Ref. No.	Location	Ref. No.	Location
D31	G-23	Q51	F-24
D101	C-4	Q52	F-25
D102	F-10	Q53	F-24
D201	C-4	Q71(MD-A)	G-19
D202	F-10	Q71(MD-HX)	G-26
D401	B-5	Q101	G-2
D402	B-5	Q102	C-3
D501	G-9	Q201	F-2
D503	E-5	Q202	B-2
D504	E-5	Q501	F-2
D701	B-7	Q502	B-3
D702	B-7	Q503	B-3
D703	B-6	Q504	G-3
D704	B-6	Q505	G-3
D705	B-8	Q506	G-9
D706	B-8	Q507	E-5
D707	B-10	Q508	D-5
D708	B-9	Q509	D-5
D709	B-8	Q510	E-6
D801	F-3	Q511	D-6
D802	F-9	Q512	E-9
D803	G-9	Q513	E-5
D804	G-10	Q514	D-6
D805	B-12	Q515	E-6
D806	B-12	Q516	D-6
D807	E-8	Q601	G-5
D808	B-7	Q701	A-9
D809	B-6	Q702	A-8
		Q703	B-8
		Q704	A-7
IC31(MD-A)	G-17	Q705	F-8
IC31(MD-HX)	G-25	Q706	F-9
IC81(SW-A)	C-22	Q801	F-9
IC81(SW-HX)	F-25	Q802	D-10
IC501	G-2	Q803	D-10
IC502	C-2	Q804	F-3
IC503	E-3	Q805	F-3
IC504	G-5	Q806	I-6
IC505	G-4	Q807	B-12
IC506	C-3	Q808	B-12
IC507	C-4	Q810	D-3
IC701	B-10	Q813	F-9
IC801	F-10	Q814	F-9
IC802	F-12	Q815	G-10
IC803	E-5	Q816	G-10
IC804	G-12		
IC805	E-9		
IC806	B-12		

Note:
 ○ : parts extracted from the component side.
 ● : parts extracted from the conductor side.
 ● : Through hole.
 ● : Pattern on the side which is seen.
 ○ : Pattern of the rear side.

G:Germany

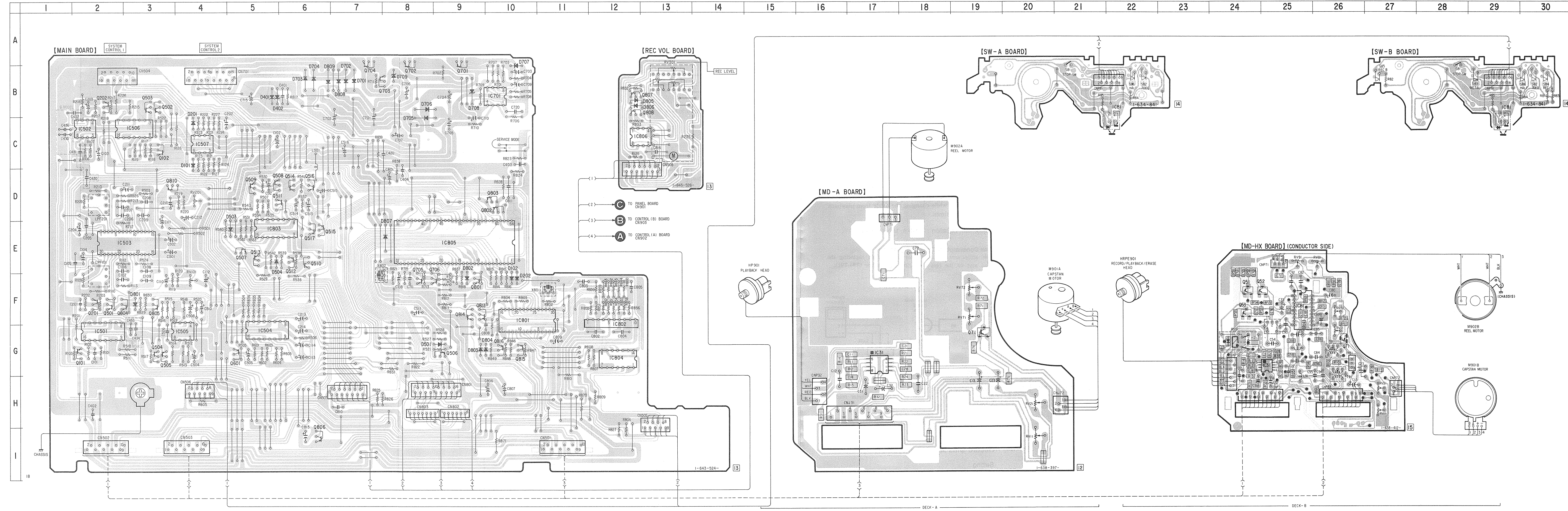

4-4. SCHEMATIC DIAGRAMS - MAIN Section -
 See page 21 for IC Block Diagrams.

- Note:
- All capacitors are in μF unless otherwise noted. pF: μF 50WV or less are not indicated except for electrolytics and tantalums.
 - All resistors are in Ω and $1/4\text{W}$ or less unless otherwise specified.
 - Δ : internal component.
 - \square : nonflammable resistor.
 - --- : B+ Line
 - --- : B- Line
 - --- : adjustment for repair.
 - Voltage is dc with respect to ground under no-signal (detuned) conditions. no mark: REC
 - Voltagcs are taken with a VOM (Input Impedance $10\text{M}\Omega$). Voltage variations may be noted due to normal production tolerances.
 - Signal path.
 - \gg : PB (DECK A)
 - \square : PB (DECK B)
 - \square : REC (DECK B)
 - G: Germany

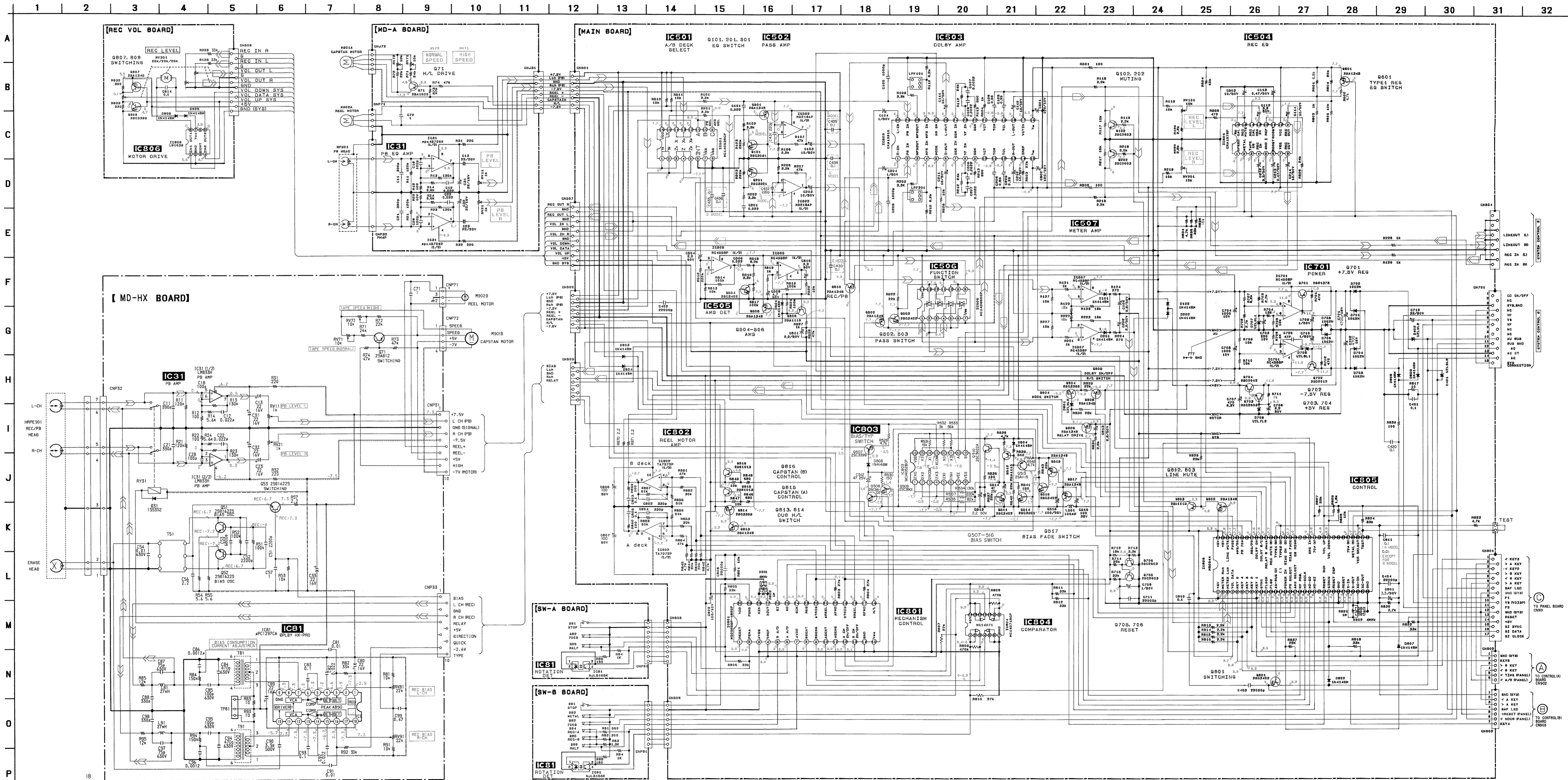

● IC Block Diagrams

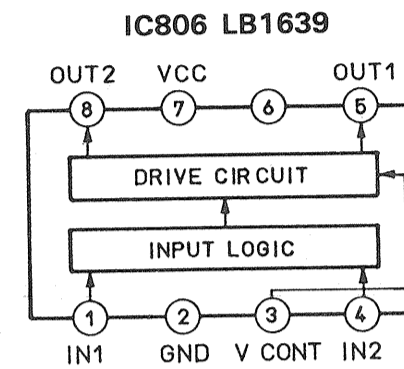
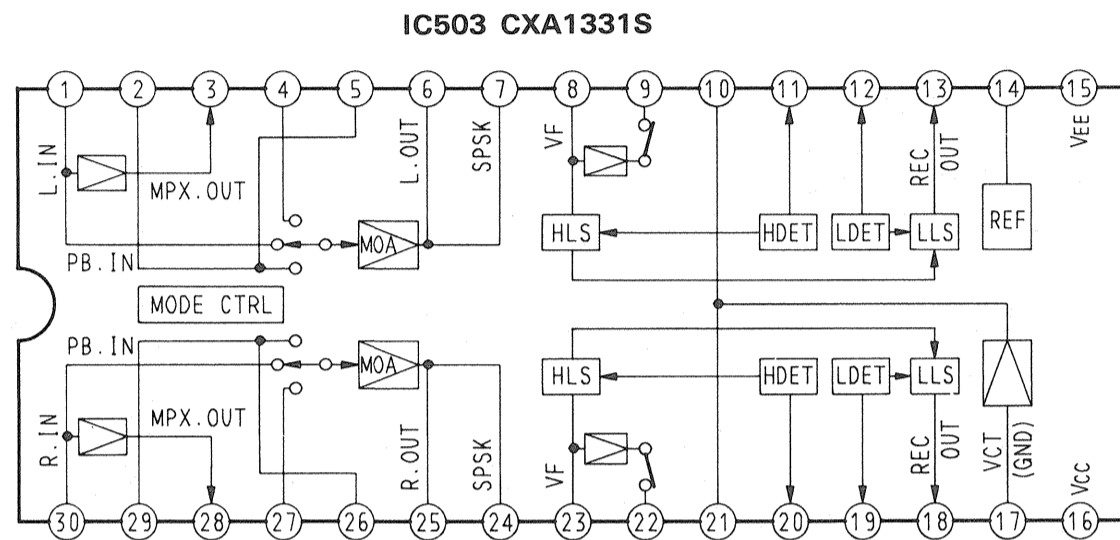
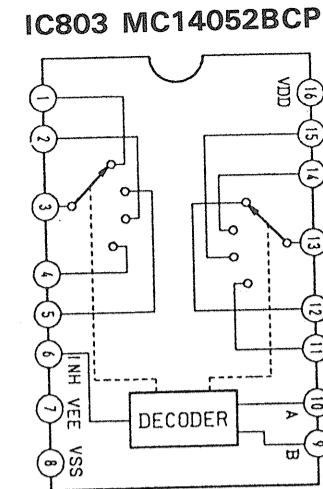
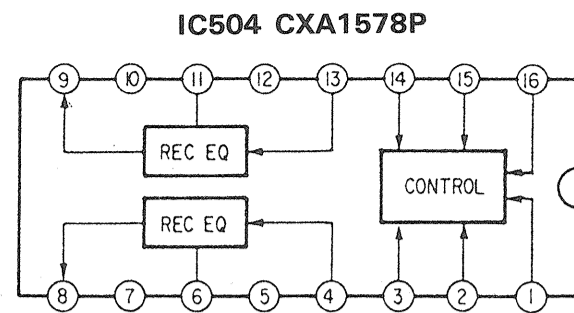
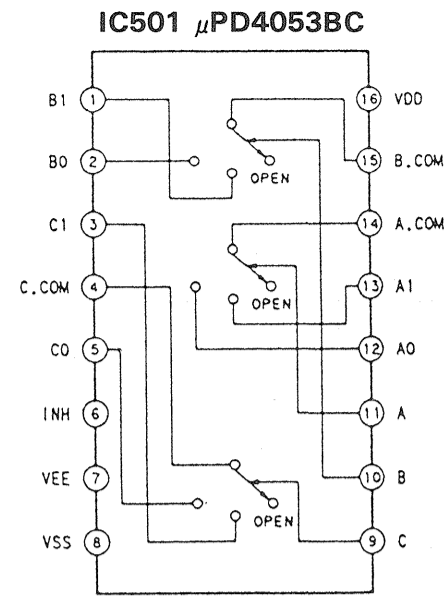

4-5. PRINTED WIRING BOARDS - PANEL Section -
• See page 10, 11 Circuit boards location and Semiconductor lead layouts.

● Semiconductor Location

Ref. No.	Location
D901	E-2
D902	E-3
D903	E-4
D904	D-4
D905	H-8
D906	B-5
IC901	B-3
Q901	D-2

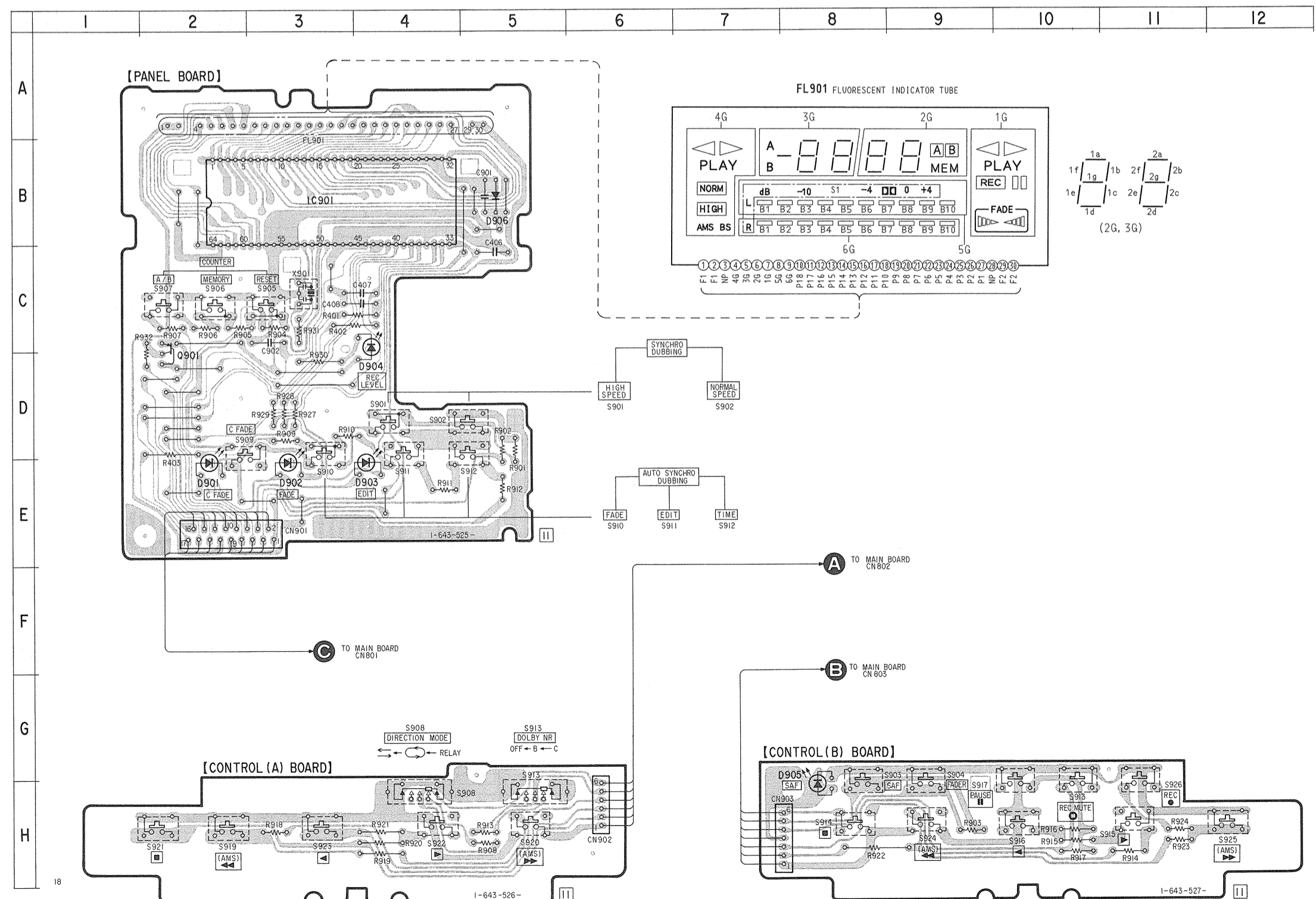

Note:
● : parts extracted from the component side.
● : Pattern on the side which is seen.

4-6. SCHEMATIC DIAGRAMS - PANEL Section-

Note:

- All capacitors are in μF unless otherwise noted. μF : $\mu\mu\text{F}$ 50WV or less are not indicated except for electrolytics and tantalums.
- All resistors are in Ω and $\frac{1}{4}\text{W}$ or less unless otherwise specified.
- Δ : internal component.
- : B+ Line
- Voltage is dc with respect to ground under no-signal (detuned) conditions. no mark : REC
- Voltages are taken with a VOM (Input Impedance $10\text{M}\Omega$). Voltage variations may be noted due to normal production tolerances.

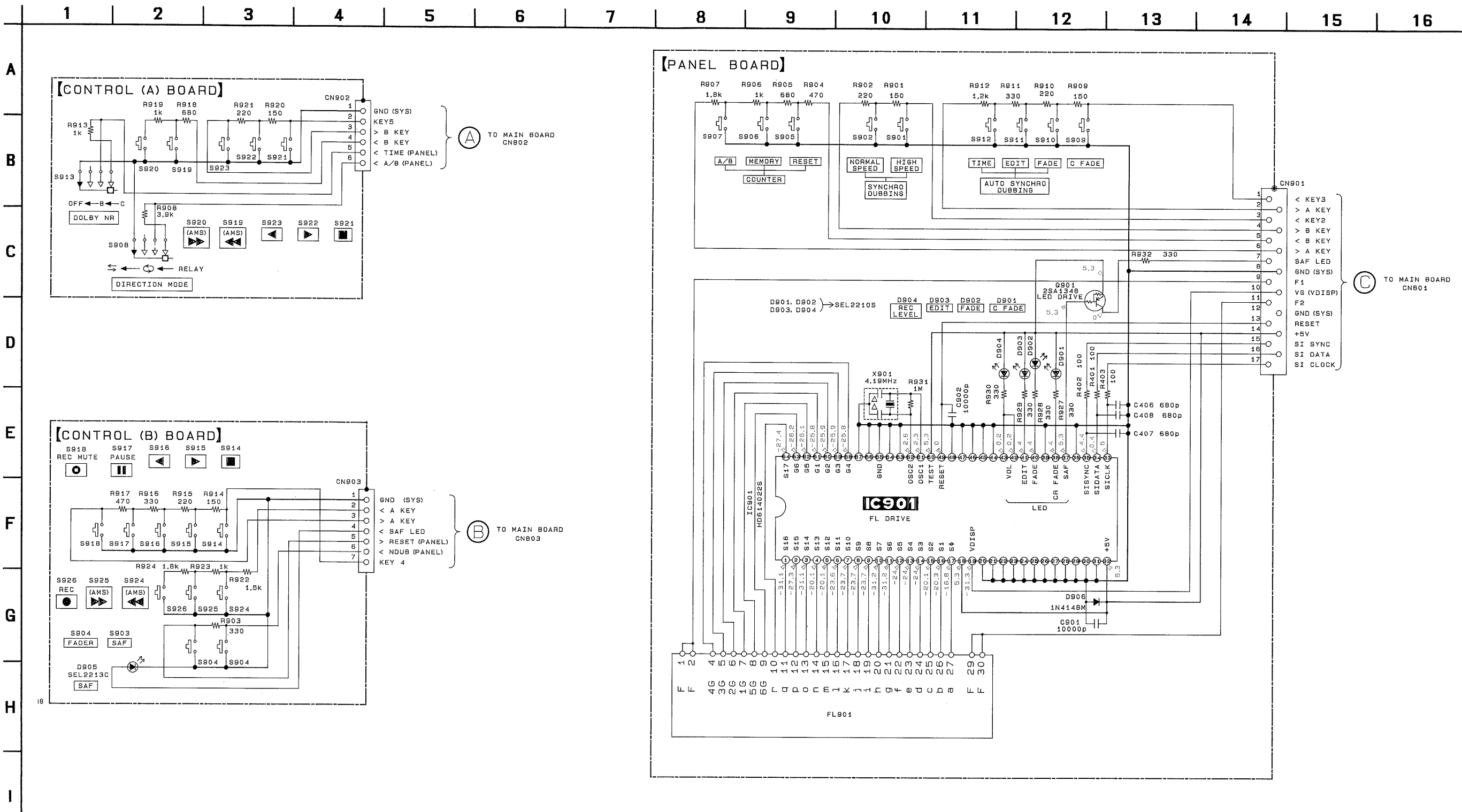

SECTION 5 EXPLODED VIEWS

NOTE:

- -XX, -X mean standardized parts, so they may have some differences from the original one.

- Color Indication of Appearance Parts

Example:

KNOB, BALANCE(WHITE)...(RED)

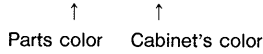

- Items marked " * " are not stocked since they are seldom required for routine service. Some delay should be anticipated when ordering these items.
- The mechanical parts with no reference number in the exploded views are not supplied.
- hardware (#mark) list is given in the last of this parts list.

G: Germany EA: Saudi Arabia
IT: Italian AUS: Australian

5-1. OVERALL SECTION

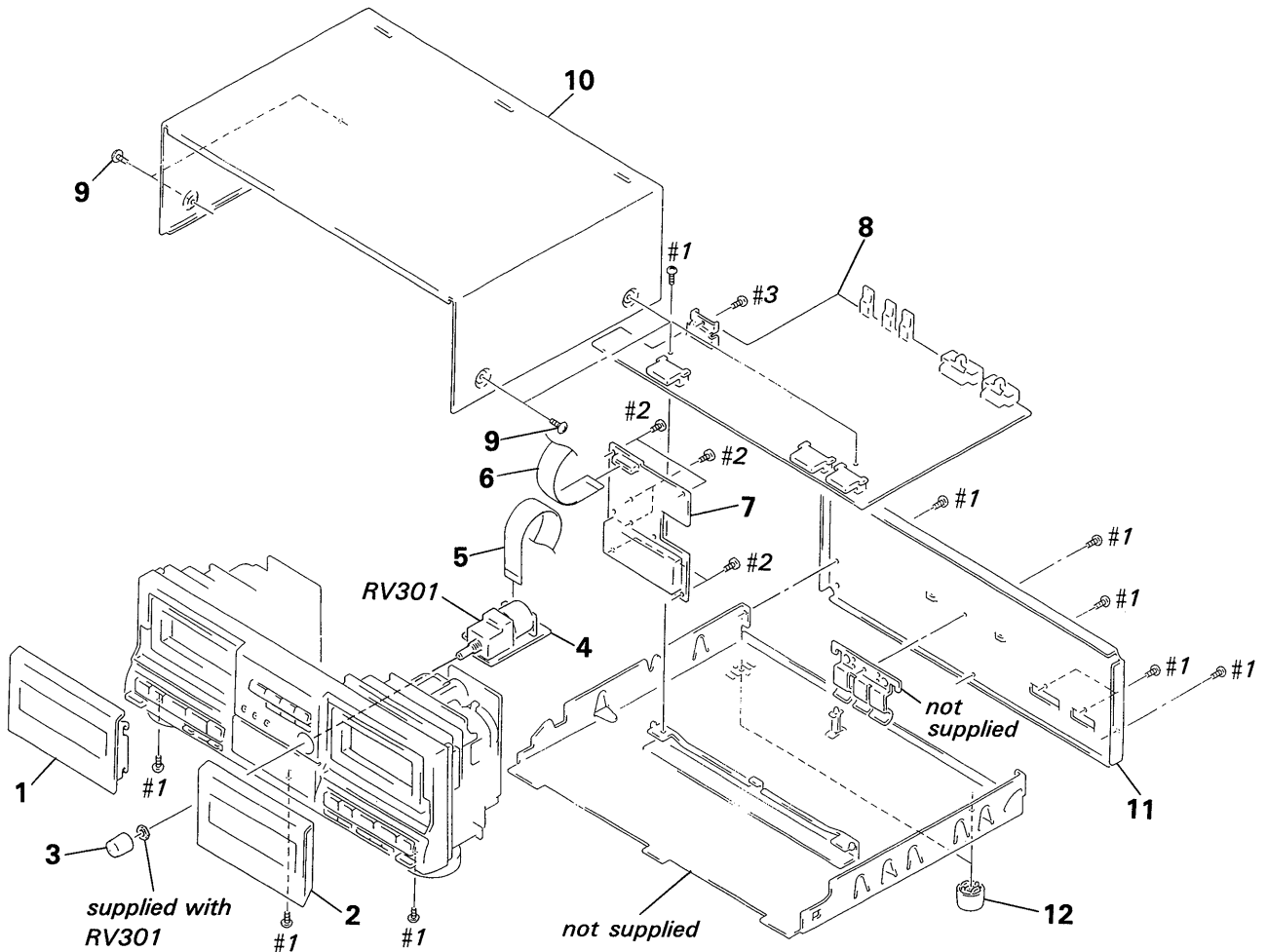

Ref. No.	Part No.	Description	Remark
1	X-3364-983-1	LID (A) ASSY, CASSETTE (EXCEPT IT)	
1	X-3364-984-1	LID (A) ASSY, CASSETTE (IT)	
2	X-3364-985-1	LID (B) ASSY, CASSETTE (EXCEPT IT)	
2	X-3364-986-1	LID (B) ASSY, CASSETTE (IT)	
3	4-950-651-21	KNOB (DIA. 16), ROUND (IT)	
3	4-950-651-31	KNOB (DIA. 16), ROUND (EXCEPT IT)	
* 4	1-643-528-11	REC VOL BOARD	
* 5	1-574-726-11	WIRE, FLAT TYPE (13 CORE)	
6	1-690-907-11	WIRE (FLAT TYPE) (17 CORE)	
* 7	A-2006-797-A	PANEL BOARD, COMPLETE	

Ref. No.	Part No.	Description	Remark
* 8	A-2006-796-A	MAIN BOARD, COMPLETE (EXCEPT G)	
* 8	A-2006-837-A	MAIN BOARD, COMPLETE (G)	
9	3-363-099-01	SCREW (CASE +3X8 TP2)	
* 10	4-939-803-31	CASE (EXCEPT IT)	
* 10	4-939-803-71	CASE (IT)	
* 11	3-377-136-51	PANEL, BACK (EXCEPT G)	
* 11	3-377-136-61	PANEL, BACK (G)	
12	4-931-169-01	FOOT	
RV301	1-241-891-11	RES, VAR, CARBON 20KX3 (REC LEVEL)	

5-2. FRONT PANEL SECTION

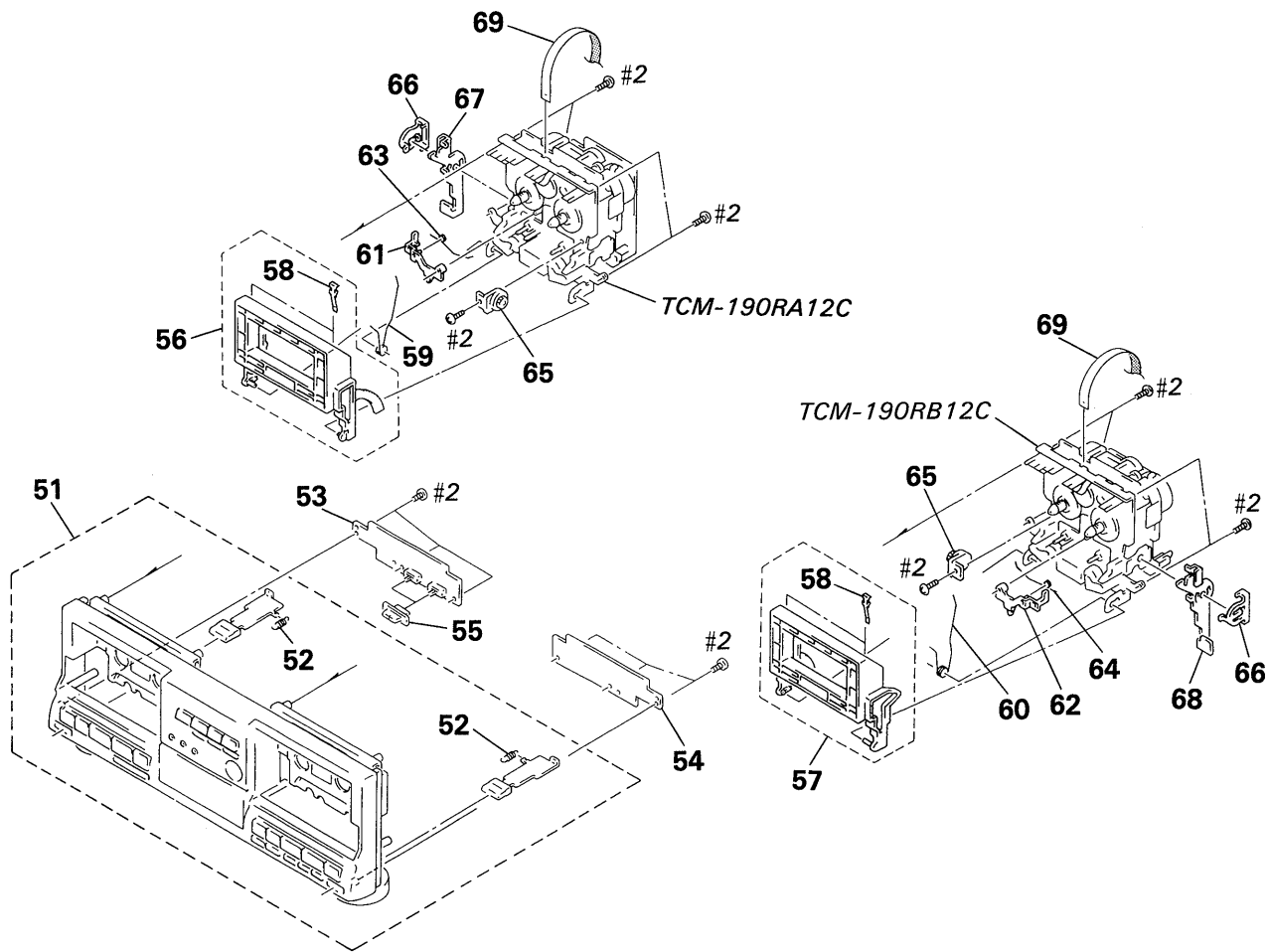

Ref. No.	Part No.	Description	Remark
51	X-3364-708-1	PANEL ASSY, FRONT (EXCEPT IT)	
51	X-3364-709-1	PANEL ASSY, FRONT (IT)	
52	3-662-752-21	SPRING, TENSION	
* 53	1-643-526-11	CONTROL (A) BOARD	
* 54	1-643-527-11	CONTROL (B) BOARD	
55	3-377-120-01	KNOB (SLIDE) (EXCEPT IT)	
55	3-377-120-11	KNOB (SLIDE) (IT)	
56	X-3340-194-1	HOLDER (L) ASSY, CASSETTE	
57	X-3340-195-1	HOLDER (R) ASSY, CASSETTE	
58	3-308-823-11	SPRING	
59	3-354-959-01	SPRING (LOADING L), TORSION	

Ref. No.	Part No.	Description	Remark
60	3-354-960-01	SPRING (LOADING R), TORSION	
61	3-354-955-01	LEVER (EJ SAFTY LEVER L)	
62	3-354-956-01	LEVER (EJ SAFTY LEVER R)	
63	3-354-961-01	SPRING (EJ SAFTY SPRING L)	
64	3-354-962-01	SPRING (EJ SAFTY SPRING R)	
65	3-354-963-01	DAMPER	
66	3-354-957-01	JOINT (LOCK LEVER)	
* 67	3-363-638-01	LEVER (LOCK LEVER L)	
* 68	3-363-639-01	LEVER (LOCK LEVER R)	
69	1-690-906-11	WIRE (FLAT TYPE) (9 CORE)	

5-3. MECHANISM SECTION-1

(TCM-190RA12C)
(TCM-190RB12C)

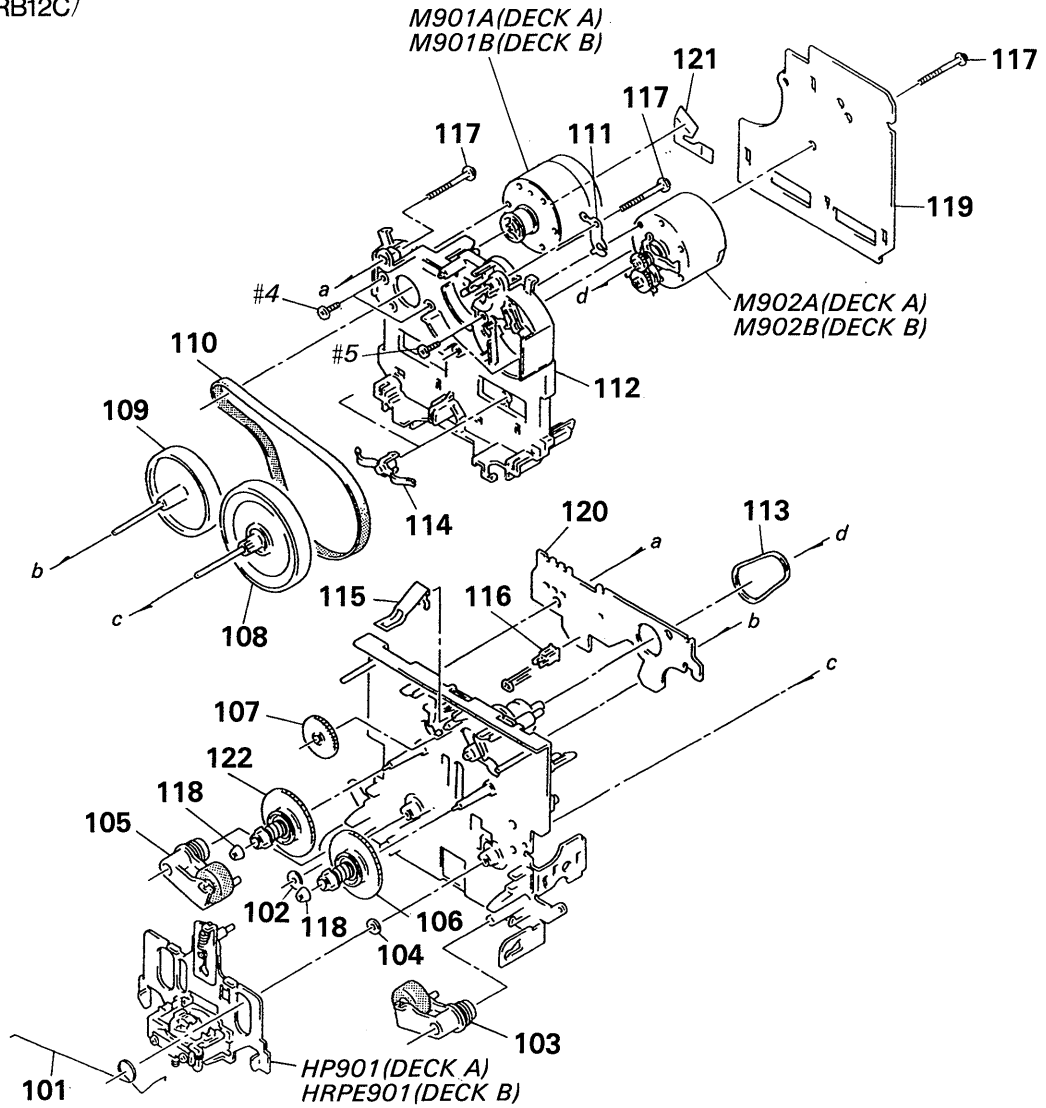

Ref. No.	Part No.	Description	Remark	Ref. No.	Part No.	Description	Remark
101	3-359-455-01	SPRING, TORSION		116	3-343-419-01	HOLDER (S SENSER A)	
102	3-356-714-01	WASHER		117	3-359-414-01	SCREW (+PTPWH 2X23)	
103	X-3359-408-1	LEVER (PINCH LEVER FWD) ASSY		118	3-362-308-01	CAP (REEL)	
104	3-356-713-01	WASHER		* 119	A-2006-399-A	MD-A BOARD, COMPLETE (DECK A)	
105	X-3359-409-1	LEVER (PINCH LEVER REV) ASSY		* 119	A-2006-401-A	MD-HX BOARD, COMPLETE (DECK B)	
106	X-3359-404-1	TABLE ASSY, REEL		* 120	1-634-841-14	SW-A BOARD (DECK A)	
107	3-359-424-01	GEAR (REV GEAR)		* 120	1-634-841-14	SW-B BOARD (DECK B)	
108	X-3364-554-1	FLYWHEEL (FWD) ASSY		121	1-638-983-11	MOTOR FLEXIBLE BOARD	
109	X-3359-410-1	FLYWHEEL (REV) ASSY		122	X-3362-078-1	TABLE ASSY (B), REEL	
110	3-359-417-01	BELT (FLAT), CAPSTAN		M901A	X-3359-417-1	MOTOR ASSY (CAPSTAN) (DECK A)	
111	3-359-450-01	PLATE, GROUND		M901B	X-3359-417-1	MOTOR ASSY (CAPSTAN) (DECK B)	
* 112	3-359-436-01	BASE (THRUST RETAINER), FITTING		M902A	X-3363-501-1	MOTOR ASSY (REEL) (DECK A)	
113	3-359-466-01	BELT (FR), SQUARE		M902B	X-3363-501-1	MOTOR ASSY (REEL) (DECK B)	
114	3-575-321-00	RETAINER, THRUST, CAPSTAN		HP901	A-2003-837-A	BASE ASSY, HEAD (PB) (DECK A)	
115	3-359-430-01	SPRING (CASSETTE RETAINER), LEAF		HRPE901A	2003-838-A	BASE ASSY, HEAD (PB/REC/ERASE) (DECK B)	

5-4. MECHANISM SECTION-2

(TCM-190RA12C)
(TCM-190RB12C)

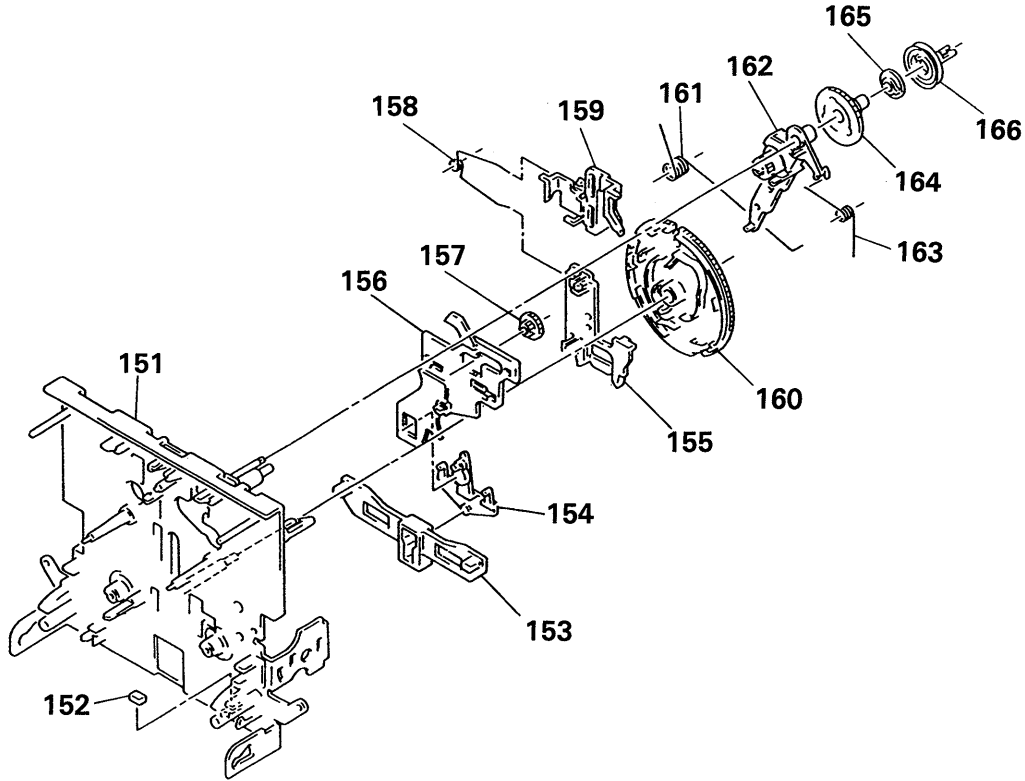

Ref. No.	Part No.	Description	Remark
151	X-3359-415-1	CHASSIS ASSY, MECHANICSL	
152	3-359-469-01	SPACER	
* 153	3-359-425-01	SLIDER (REVERSE SLIDER)	
154	3-359-426-01	LEVER (REVERSE LEVER)	
* 155	3-359-427-01	SLIDER (LEVERSE SLIDER)	
* 156	3-359-415-01	SLIDER (TRIGGER SLIDER)	
157	3-359-448-01	GEAR (TRIGGER)	
158	3-359-454-01	SPRING, TORSION	

Ref. No.	Part No.	Description	Remark
159	3-359-429-01	SLIDER (BRAKE PLATE)	
160	3-359-420-01	GEAR (CAM GEAR)	
161	3-359-456-01	SPRING (TRIGGER SPRING), TORSION	
162	X-3359-405-1	LEVER (FR ARM) ASSY	
163	3-359-453-01	SPRING (FR ARM), TORSION	
164	3-359-419-01	GEAR (FR GEAR)	
165	3-359-421-01	CLUTCH (REEL DISK)	
166	3-359-418-01	PULLEY (FR PULLEY)	

SECTION 6 ELECTRICAL PARTS LIST

CONTROL (A)

COTROL (B)

MAIN

NOTE:

- Due to standardization, replacements in the parts list may be different from the parts specified in the diagrams or the components used on the set.
- -XX and -X mean standardized parts, so they may have some difference from the original one.
- RESISTORS
All resistors are in ohms.
METAL: Metal-film resistor.
METAL OXIDE: Metal oxide-film resistor.
F: nonflammable

- Items marked "*" are not stocked since they are seldom required for routine service. Some delay should be anticipated when ordering these items.
- SEMICONDUCTORS
In each case, u: μ , for example:
uA ..: μ A.. uPA..: μ PA..
uPB..: μ PB.. uPC..: μ PC.. uPD..: μ PD..
- CAPACITORS
uF: μ F
- COILS
uH: μ H
- G: Germany

The components identified by mark Δ or dotted line with mark Δ are critical for safety. Replace only with part number specified.

When indicating parts by reference number, please include the board.

Ref. No.	Part No.	Description	Remark
*	1-643-526-11	CONTROL (A) BOARD *****	
		< CONNECTOR >	
*CN902	1-564-499-11	PIN, CONNECTOR 6P < RESISTOR >	
R908	1-249-424-11	CARBON 3.9K 5% 1/4W	
R913	1-249-417-11	CARBON 1K 5% 1/4W	
R918	1-249-415-11	CARBON 680 5% 1/4W	
R919	1-249-417-11	CARBON 1K 5% 1/4W	
R920	1-249-407-11	CARBON 150 5% 1/4W	
R921	1-249-409-11	CARBON 220 5% 1/4W < SWITCH >	
S908	1-572-378-11	SWITCH, SLIDE (DIRECTION MODE)	
S913	1-572-378-11	SWITCH, SLIDE (DOLBY NR)	
S919	1-554-303-21	SWITCH, TACTILE (AMS REW)	
S920	1-554-303-21	SWITCH, TACTILE (AMS FF)	
S921	1-554-303-21	SWITCH, TACTILE (STOP)	
S922	1-554-303-21	SWITCH, TACTILE (FWD)	
S923	1-554-303-21	SWITCH, TACTILE (REV)	

*	1-643-527-11	CONTROL (B) BOARD *****	
		< CONNECTOR >	
*CN903	1-564-500-11	PIN, CONNECTOR 7P < DIODE >	
D905	8-719-302-23	LED SEL2213C-C (SAF)	

Ref. No.	Part No.	Description	Remark
		< RESISTOR >	
R903	1-249-411-11	CARBON 330 5% 1/4W	
R914	1-249-407-11	CARBON 150 5% 1/4W	
R915	1-249-409-11	CARBON 220 5% 1/4W	
R916	1-249-411-11	CARBON 330 5% 1/4W	
R917	1-249-413-11	CARBON 470 5% 1/4W	
R922	1-249-419-11	CARBON 1.5K 5% 1/4W	
R923	1-249-417-11	CARBON 1K 5% 1/4W	
R924	1-249-420-11	CARBON 1.8K 5% 1/4W	
		< SWITCH >	
S903	1-554-303-21	SWITCH, TACTILE (SAF)	
S904	1-554-303-21	SWITCH, TACTILE (FADER)	
S914	1-554-303-21	SWITCH, TACTILE (STOP)	
S915	1-554-303-21	SWITCH, TACTILE (FWD)	
S916	1-554-303-21	SWITCH, TACTILE (REV)	
S917	1-554-303-21	SWITCH, TACTILE (PAUSE)	
S918	1-554-303-21	SWITCH, TACTILE (REC MUTE)	
S924	1-554-303-21	SWITCH, TACTILE (AMS REW)	
S925	1-554-303-21	SWITCH, TACTILE (AMS FF)	
S926	1-554-303-21	SWITCH, TACTILE (REC)	

*	A-2006-796-A	MAIN BOARD, COMPLETE (EXCEPT G)	
*	A-2006-837-A	MAIN BOARD, COMPLETE (G) *****	
	4-942-204-01	PLATE, GROUND	
	7-685-645-79	SCREW +BVTP 3X6 TYPE2 N-S	
		< CAPACITOR >	
C101	1-136-157-00	FILM 0.022uF 5% 50V	
C102	1-126-161-11	ELECT 2.2uF 20% 50V	
C103	1-126-059-11	ELECT 10uF 20% 50V	
C104	1-126-301-11	ELECT 1uF 20% 50V	

MAIN

Ref. No.	Part No.	Description			Remark	Ref. No.	Part No.	Description			Remark
C105	1-162-294-31	CERAMIC	0.001uF	10%	50V	C701	1-126-937-11	ELECT	4700uF	20%	16V
C106	1-130-475-00	MYLAR	0.0022uF	5%	50V	C702	1-126-937-11	ELECT	4700uF	20%	16V
C107	1-130-475-00	MYLAR	0.0022uF	5%	50V	C703	1-126-101-11	ELECT	100uF	20%	16V
C108	1-136-174-00	FILM	0.56uF	5%	50V	C704	1-124-473-11	ELECT	1000uF	20%	10V
C109	1-136-171-00	FILM	0.33uF	5%	50V	C705	1-124-473-11	ELECT	1000uF	20%	10V
C110	1-126-059-11	ELECT	10uF	20%	50V	C706	1-126-161-11	ELECT	2.2uF	20%	50V
C111	1-126-059-11	ELECT	10uF	20%	50V	C707	1-124-472-11	ELECT	470uF	20%	10V
C112	1-126-162-11	ELECT	3.3uF	20%	50V	C708	1-126-301-11	ELECT	1uF	20%	50V
C113	1-126-300-11	ELECT	0.47uF	20%	50V	C709	1-126-301-11	ELECT	1uF	20%	50V
C114	1-126-059-11	ELECT	10uF	20%	50V	C710	1-126-301-11	ELECT	1uF	20%	50V
C201	1-136-157-00	FILM	0.022uF	5%	50V	C711	1-101-005-00	CERAMIC	22000PF		50V
C202	1-126-161-11	ELECT	2.2uF	20%	50V	C712	1-126-867-11	ELECT	33uF	20%	50V
C203	1-126-059-11	ELECT	10uF	20%	50V	C720	1-162-215-31	CERAMIC	47PF	5%	50V
C204	1-126-301-11	ELECT	1uF	20%	50V	C801	1-126-162-11	ELECT	3.3uF	20%	50V
C205	1-162-294-31	CERAMIC	0.001uF	10%	50V	C802	1-162-288-31	CERAMIC	330PF	10%	50V
C206	1-130-475-00	MYLAR	0.0022uF	5%	50V	C803	1-136-165-00	FILM	0.1uF	5%	50V
C207	1-130-475-00	MYLAR	0.0022uF	5%	50V	C804	1-162-288-31	CERAMIC	330PF	10%	50V
C208	1-136-174-00	FILM	0.56uF	5%	50V	C805	1-136-165-00	FILM	0.1uF	5%	50V
C209	1-136-171-00	FILM	0.33uF	5%	50V	C806	1-124-994-11	ELECT	100uF	20%	10V
C210	1-126-059-11	ELECT	10uF	20%	50V	C807	1-124-994-11	ELECT	100uF	20%	10V
C211	1-126-059-11	ELECT	10uF	20%	50V	C808	1-101-005-00	CERAMIC	22000PF		50V
C212	1-126-162-11	ELECT	3.3uF	20%	50V	C809	1-124-994-11	ELECT	100uF	20%	10V
C213	1-126-300-11	ELECT	0.47uF	20%	50V	C810	1-136-165-00	FILM	0.1uF	5%	50V
C214	1-126-059-11	ELECT	10uF	20%	50V	C811	1-161-379-00	CERAMIC	0.01uF	20%	25V
C401	1-164-159-11	CERAMIC	0.1uF		50V						(EXCEPT G)
C402	1-101-005-00	CERAMIC	22000PF		50V	C811	1-164-159-11	CERAMIC	0.1uF		50V (G)
C403	1-101-005-00	CERAMIC	22000PF		50V	C813	1-126-161-11	ELECT	2.2uF	20%	50V
C404	1-101-005-00	CERAMIC	22000PF		50V						< CONNECTOR >
C420	1-164-159-11	CERAMIC	0.1uF		50V						
C430	1-164-159-11	CERAMIC	0.1uF		50V (G)						
C431	1-162-286-31	CERAMIC	220PF	10%	50V (G)	*CN501	1-580-784-11	CONNECTOR, BOARD TO BOARD			
C432	1-162-286-31	CERAMIC	220PF	10%	50V (G)	*CN502	1-580-784-11	CONNECTOR, BOARD TO BOARD			
C433	1-164-159-11	CERAMIC	0.1uF		50V (G)	*CN503	1-580-784-11	CONNECTOR, BOARD TO BOARD			
C434	1-164-159-11	CERAMIC	0.1uF		50V (G)	*CN504	1-566-858-41	SOCKET, CONNECTOR 11P			
C435	1-164-159-11	CERAMIC	0.1uF		50V (G)	*CN505	1-568-828-11	SOCKET, CONNECTOR 9P			
C436	1-164-159-11	CERAMIC	0.1uF		50V (G)	*CN506	1-568-828-11	SOCKET, CONNECTOR 9P			
C501	1-124-994-11	ELECT	100uF	20%	10V	*CN507	1-568-832-11	SOCKET, CONNECTOR 13P			
C502	1-124-994-11	ELECT	100uF	20%	10V	*CN701	1-566-859-11	SOCKET, CONNECTOR 15P			
C503	1-126-059-11	ELECT	10uF	20%	50V	*CN801	1-568-836-11	SOCKET, CONNECTOR 17P			
C504	1-126-161-11	ELECT	2.2uF	20%	50V	*CN802	1-564-340-61	PIN, CONNECTOR 6P			
C506	1-161-494-00	CERAMIC	0.022uF		25V	*CN803	1-564-341-11	PIN, CONNECTOR 7P			
C508	1-126-163-11	ELECT	4.7uF	20%	50V						< DIODE >
C510	1-126-161-11	ELECT	2.2uF	20%	50V	D101	8-719-987-63	DIODE	1N4148M		
C511	1-126-161-11	ELECT	2.2uF	20%	50V	D102	8-719-987-63	DIODE	1N4148M		
C512	1-124-910-11	ELECT	47uF	20%	50V	D201	8-719-987-63	DIODE	1N4148M		
C513	1-126-161-11	ELECT	2.2uF	20%	50V	D202	8-719-987-63	DIODE	1N4148M		
C514	1-124-910-11	ELECT	47uF	20%	50V	D401	8-719-933-54	DIODE	HZS9A2L		
C515	1-124-478-11	ELECT	100uF	20%	25V	D402	8-719-933-54	DIODE	HZS9A2L		
C516	1-124-478-11	ELECT	100uF	20%	25V						

Ref. No.	Part No.	Description	Remark	Ref. No.	Part No.	Description	Remark
D501	8-719-987-63	DIODE	1N4148M	Q502	8-729-900-61	TRANSISTOR	DTA114ES
D503	8-719-987-63	DIODE	1N4148M	Q503	8-729-900-80	TRANSISTOR	DTC114ES
D504	8-719-987-63	DIODE	1N4148M	Q504	8-729-900-80	TRANSISTOR	DTC114ES
D701	8-719-200-77	DIODE	10E2N	Q505	8-729-900-61	TRANSISTOR	DTA114ES
D702	8-719-200-77	DIODE	10E2N	Q506	8-729-119-76	TRANSISTOR	2SA1175-HFE
D703	8-719-200-77	DIODE	10E2N	Q507	8-729-900-89	TRANSISTOR	DTC144ES
D704	8-719-200-77	DIODE	10E2N	Q508	8-729-900-80	TRANSISTOR	DTC114ES
D705	8-719-200-77	DIODE	10E2N	Q509	8-729-900-74	TRANSISTOR	DTC143TS
D706	8-719-200-77	DIODE	10E2N	Q510	8-729-141-26	TRANSISTOR	2SC3622A-LK
D707	8-719-933-33	DIODE	HZS6A1L	Q511	8-729-900-80	TRANSISTOR	DTC114ES
D708	8-719-933-33	DIODE	HZS6A1L	Q512	8-729-119-76	TRANSISTOR	2SA1175-HFE
D709	8-719-000-78	DIODE	UZL-7L2	Q513	8-729-119-76	TRANSISTOR	2SA1175-HFE
D801	8-719-933-54	DIODE	HZS9A2L	Q514	8-729-900-74	TRANSISTOR	DTC143TS
D802	8-719-987-63	DIODE	1N4148M	Q515	8-729-900-61	TRANSISTOR	DTA114ES
D803	8-719-987-63	DIODE	1N4148M	Q516	8-729-900-80	TRANSISTOR	DTC114ES
D804	8-719-987-63	DIODE	1N4148M	Q517	8-729-900-61	TRANSISTOR	DTA114ES
D807	8-719-987-63	DIODE	1N4148M	Q601	8-729-900-65	TRANSISTOR	DTA144ES
D808	8-719-987-63	DIODE	1N4148M	Q701	8-729-141-83	TRANSISTOR	2SB1094-LK
D809	8-719-987-63	DIODE	1N4148M	Q702	8-729-209-15	TRANSISTOR	2SD2012
		< IC >		Q703	8-729-620-05	TRANSISTOR	2SC2603-EF
IC501	8-759-140-53	IC	μPD4053BC	Q704	8-729-209-15	TRANSISTOR	2SD2012
IC502	8-759-634-51	IC	M5218AP	Q705	8-729-620-05	TRANSISTOR	2SC2603-EF
IC503	8-752-059-55	IC	CXA1331S	Q706	8-729-620-05	TRANSISTOR	2SC2603-EF
IC504	8-752-055-61	IC	CXA1578P	Q801	8-729-900-80	TRANSISTOR	DTC114ES
IC505	8-759-945-58	IC	RC4558P	Q802	8-729-900-61	TRANSISTOR	DTA114ES
IC506	8-759-000-49	IC	MC14066BCP	Q803	8-729-119-76	TRANSISTOR	2SA1175-HFE
IC507	8-759-945-58	IC	RC4558P	Q804	8-729-900-89	TRANSISTOR	DTC144ES
IC701	8-759-945-58	IC	RC4558P	Q805	8-729-900-65	TRANSISTOR	DTA144ES
IC801	8-759-635-94	IC	M50925SP-482SP	Q806	8-729-900-61	TRANSISTOR	DTA114ES
IC802	8-759-207-05	IC	TA7272P	Q810	8-729-900-61	TRANSISTOR	DTA114ES
IC803	8-759-000-48	IC	MC14052BCP	Q813	8-729-900-61	TRANSISTOR	DTA114ES
IC804	8-759-240-71	IC	TC4071BP	Q814	8-729-900-89	TRANSISTOR	DTC144ES
IC805	8-759-067-45	IC	M50944-180SP	Q815	8-729-801-84	TRANSISTOR	2SB1013-4
		< COIL >		Q816	8-729-801-84	TRANSISTOR	2SB1013-4
L501	1-408-080-00	INDUCTOR	100μH			< RESISTOR >	
		< FILTER >		R101	1-249-421-11	CARBON	2.2K 5% 1/4W
LPF101	1-236-087-11	FILTER, LOW PASS		R102	1-249-423-11	CARBON	3.3K 5% 1/4W
LPF201	1-236-087-11	FILTER, LOW PASS		R103	1-247-887-00	CARBON	220K 5% 1/4W
		< TRANSISTOR >		R106	1-249-421-11	CARBON	2.2K 5% 1/4W
Q101	8-729-900-74	TRANSISTOR	DTC143TS	R107	1-249-437-11	CARBON	47K 5% 1/4W
Q102	8-729-620-05	TRANSISTOR	2SC2603-EF	R109	1-249-423-11	CARBON	3.3K 5% 1/4W
Q201	8-729-900-74	TRANSISTOR	DTC143TS	R110	1-249-428-11	CARBON	8.2K 5% 1/4W
Q202	8-729-620-05	TRANSISTOR	2SC2603-EF	R112	1-247-864-11	CARBON	24K 5% 1/4W
Q501	8-729-900-61	TRANSISTOR	DTA114ES	R113	1-249-414-11	CARBON	560 5% 1/4W
				R115	1-249-421-11	CARBON	2.2K 5% 1/4W
				R117	1-249-431-11	CARBON	15K 5% 1/4W
				R118	1-249-421-11	CARBON	2.2K 5% 1/4W
				R119	1-249-429-11	CARBON	10K 5% 1/4W

MAIN

Ref. No.	Part No.	Description	Remark			Ref. No.	Part No.	Description	Remark		
R120	1-249-421-11	CARBON	2. 2K	5%	1/4W	R527	1-249-417-11	CARBON	1K	5%	1/4W
R121	1-249-417-11	CARBON	1K	5%	1/4W	R528	1-249-437-11	CARBON	47K	5%	1/4W
R122	1-249-432-11	CARBON	18K	5%	1/4W	R529	1-249-425-11	CARBON	4. 7K	5%	1/4W
R123	1-249-432-11	CARBON	18K	5%	1/4W	R530	1-249-407-11	CARBON	150	5%	1/4W
R124	1-249-410-11	CARBON	270	5%	1/4W	R531	1-249-431-11	CARBON	15K	5%	1/4W
R126	1-249-417-11	CARBON	1K	5%	1/4W	R532	1-247-842-11	CARBON	3K	5%	1/4W
R127	1-249-429-11	CARBON	10K	5%	1/4W	R533	1-249-438-11	CARBON	56K	5%	1/4W
R201	1-249-421-11	CARBON	2. 2K	5%	1/4W	R534	1-247-882-11	CARBON	130K	5%	1/4W
R202	1-249-423-11	CARBON	3. 3K	5%	1/4W	R535	1-249-440-11	CARBON	82K	5%	1/4W
R203	1-247-887-00	CARBON	220K	5%	1/4W	R536	1-249-405-11	CARBON	100	5%	1/4W
R206	1-249-421-11	CARBON	2. 2K	5%	1/4W	R537	1-249-433-11	CARBON	22K	5%	1/4W
R207	1-249-437-11	CARBON	47K	5%	1/4W	R538	1-249-425-11	CARBON	4. 7K	5%	1/4W
R209	1-249-423-11	CARBON	3. 3K	5%	1/4W	R539	1-249-414-11	CARBON	560	5%	1/4W
R210	1-249-428-11	CARBON	8. 2K	5%	1/4W	R540	1-249-433-11	CARBON	22K	5%	1/4W
R212	1-247-864-11	CARBON	24K	5%	1/4W	R541	1-249-407-11	CARBON	150	5%	1/4W
R213	1-249-414-11	CARBON	560	5%	1/4W	R542	1-249-425-11	CARBON	4. 7K	5%	1/4W
R215	1-249-421-11	CARBON	2. 2K	5%	1/4W	R543	1-249-433-11	CARBON	22K	5%	1/4W
R217	1-249-431-11	CARBON	15K	5%	1/4W	R601	1-249-427-11	CARBON	6. 8K	5%	1/4W
R218	1-249-421-11	CARBON	2. 2K	5%	1/4W	R602	1-249-425-11	CARBON	4. 7K	5%	1/4W
R219	1-249-429-11	CARBON	10K	5%	1/4W	R603	1-249-417-11	CARBON	1K	5%	1/4W
R220	1-249-421-11	CARBON	2. 2K	5%	1/4W	R604	1-247-862-11	CARBON	20K	5%	1/4W
R221	1-249-417-11	CARBON	1K	5%	1/4W	R605	1-249-429-11	CARBON	10K	5%	1/4W
R222	1-249-432-11	CARBON	18K	5%	1/4W	R701	1-249-413-11	CARBON	470	5%	1/4W
R223	1-249-432-11	CARBON	18K	5%	1/4W	R702	1-249-413-11	CARBON	470	5%	1/4W
R224	1-249-410-11	CARBON	270	5%	1/4W	R703	1-249-422-11	CARBON	2. 7K	5%	1/4W
R226	1-249-417-11	CARBON	1K	5%	1/4W	R704	1-247-858-11	CARBON	13K	5%	1/4W
R227	1-249-429-11	CARBON	10K	5%	1/4W	R705	1-249-429-11	CARBON	10K	5%	1/4W
R501	1-249-405-11	CARBON	100	5%	1/4W	R706	1-249-417-11	CARBON	1K	5%	1/4W
R502	1-249-405-11	CARBON	100	5%	1/4W	R707	1-247-850-11	CARBON	6. 2K	5%	1/4W
R503	1-249-434-11	CARBON	27K	5%	1/4W	R708	1-249-422-11	CARBON	2. 7K	5%	1/4W
R504	1-249-429-11	CARBON	10K	5%	1/4W	R709	1-249-429-11	CARBON	10K	5%	1/4W
R505	1-249-413-11	CARBON	470	5%	1/4W	R710	1-249-429-11	CARBON	10K	5%	1/4W
R506	1-247-864-11	CARBON	24K	5%	1/4W	R711	1-249-417-11	CARBON	1K	5%	1/4W
R507	1-247-887-00	CARBON	220K	5%	1/4W	R712	1-249-432-11	CARBON	18K	5%	1/4W
R510	1-249-429-11	CARBON	10K	5%	1/4W	R713	1-249-423-11	CARBON	3. 3K	5%	1/4W
R511	1-249-429-11	CARBON	10K	5%	1/4W	R714	1-249-433-11	CARBON	22K	5%	1/4W
R512	1-247-887-00	CARBON	220K	5%	1/4W	R715	1-249-435-11	CARBON	33K	5%	1/4W
R513	1-249-429-11	CARBON	10K	5%	1/4W	R801	1-249-429-11	CARBON	10K	5%	1/4W
R514	1-249-441-11	CARBON	100K	5%	1/4W	R802	1-247-903-00	CARBON	1M	5%	1/4W
R515	1-249-428-11	CARBON	8. 2K	5%	1/4W	R803	1-249-434-11	CARBON	27K	5%	1/4W
R516	1-249-423-11	CARBON	3. 3K	5%	1/4W	R804	1-249-434-11	CARBON	27K	5%	1/4W
R517	1-249-441-11	CARBON	100K	5%	1/4W	R805	1-249-435-11	CARBON	33K	5%	1/4W
R518	1-249-417-11	CARBON	1K	5%	1/4W	R806	1-249-435-11	CARBON	33K	5%	1/4W
R519	1-249-441-11	CARBON	100K	5%	1/4W	R807	1-249-434-11	CARBON	27K	5%	1/4W
R520	1-249-429-11	CARBON	10K	5%	1/4W	R808	1-247-895-00	CARBON	470K	5%	1/4W
R521	1-249-441-11	CARBON	100K	5%	1/4W	R809	1-247-895-00	CARBON	470K	5%	1/4W
R522	1-249-433-11	CARBON	22K	5%	1/4W	R810	1-249-434-11	CARBON	27K	5%	1/4W
R524	1-249-417-11	CARBON	1K	5%	1/4W	R811	1-249-435-11	CARBON	33K	5%	1/4W
R526	1-249-429-11	CARBON	10K	5%	1/4W	R812	1-249-435-11	CARBON	33K	5%	1/4W

MAIN

MD-A

Ref. No.	Part No.	Description	Remark	Ref. No.	Part No.	Description	Remark
R813	1-249-421-11	CARBON	2. 2K 5% 1/4W			< VIBRATOR >	
R814	1-249-421-11	CARBON	2. 2K 5% 1/4W				
R815	1-249-421-11	CARBON	2. 2K 5% 1/4W	X801	1-577-358-21	VIBRATOR, CERAMIC 4MHz	
R816	1-249-421-11	CARBON	2. 2K 5% 1/4W	X802	1-577-358-21	VIBRATOR, CERAMIC 4MHz	
R817	1-249-393-11	CARBON	10 5% 1/4W	*****			
R818	1-249-435-11	CARBON	33K 5% 1/4W	*	A-2006-399-A	MD-A BOARD, COMPLETE	
R821	1-247-903-00	CARBON	1M 5% 1/4W	*****			
R822	1-249-435-11	CARBON	33K 5% 1/4W			< CAPACITOR >	
R823	1-249-425-11	CARBON	4. 7K 5% 1/4W				
R824	1-249-435-11	CARBON	33K 5% 1/4W	C11	1-163-131-00	CERAMIC CHIP 390PF 5% 50V	
R825	1-249-429-11	CARBON	10K 5% 1/4W	C12	1-136-157-00	FILM 0. 022uF 5% 50V	
R826	1-249-420-11	CARBON	1. 8K 5% 1/4W	C13	1-124-234-00	ELECT 22uF 20% 16V	
R827	1-249-435-11	CARBON	33K 5% 1/4W	C18	1-163-117-00	CERAMIC CHIP 100PF 5% 50V	
R828	1-249-433-11	CARBON	22K 5% 1/4W	C21	1-163-131-00	CERAMIC CHIP 390PF 5% 50V	
R829	1-249-433-11	CARBON	22K 5% 1/4W	C22	1-136-157-00	FILM 0. 022uF 5% 50V	
R830	1-249-433-11	CARBON	22K 5% 1/4W	C23	1-124-234-00	ELECT 22uF 20% 16V	
R831	1-249-421-11	CARBON	2. 2K 5% 1/4W	C28	1-163-117-00	CERAMIC CHIP 100PF 5% 50V	
R834	1-249-425-11	CARBON	4. 7K 5% 1/4W	C31	1-124-234-00	ELECT 22uF 20% 16V	
R835	1-249-435-11	CARBON	33K 5% 1/4W	C32	1-124-234-00	ELECT 22uF 20% 16V	
R836	1-249-435-11	CARBON	33K 5% 1/4W	C72	1-124-499-11	ELECT, NONPOLAR R 1uF 20% 50V	
R837	1-249-431-11	CARBON	15K 5% 1/4W			< JACK >	
R838	1-249-422-11	CARBON	2. 7K 5% 1/4W	*CNJ31	1-580-782-11	CONNECTOR, BOARD TO BOARD	
R839	1-249-405-11	CARBON	100 5% 1/4W	*CNJ72	1-580-411-11	SOCKET, CONNECTOR 4P	
R842	1-249-425-11	CARBON	4. 7K 5% 1/4W			< CONNECTOR >	
R843	1-247-862-11	CARBON	20K 5% 1/4W	*CNP32	1-580-772-11	PIN, CONNECTOR (PC BOARD) 4P	
R844	1-247-862-11	CARBON	20K 5% 1/4W	*CNP71	1-564-719-11	PIN, CONNECTOR (SMALL TYPE) 3P	
R845	1-249-425-11	CARBON	4. 7K 5% 1/4W			< IC >	
R846	1-249-415-11	CARBON	680 5% 1/4W	IC31	8-759-106-02	IC uPC4570G2	
R847	1-249-429-11	CARBON	10K 5% 1/4W			< JUMPER RESISTOR >	
R848	1-249-415-11	CARBON	680 5% 1/4W	JW1	1-216-295-00	METAL CHIP 0 5% 1/10W	
R849	1-249-429-11	CARBON	10K 5% 1/4W	JW51	1-216-296-00	METAL CHIP 0 5% 1/8W	
R851	1-249-437-11	CARBON	47K 5% 1/4W	JW52	1-216-296-00	METAL CHIP 0 5% 1/8W	
R852	1-247-866-11	CARBON	30K 5% 1/4W	JW53	1-216-296-00	METAL CHIP 0 5% 1/8W	
R853	1-247-866-11	CARBON	30K 5% 1/4W	JW54	1-216-296-00	METAL CHIP 0 5% 1/8W	
R854	1-249-437-11	CARBON	47K 5% 1/4W			< TRANSISTOR >	
R855	1-247-872-11	CARBON	51K 5% 1/4W	Q71	8-729-602-36	TRANSISTOR 2SA1602	
R856	1-247-872-11	CARBON	51K 5% 1/4W			< RESISTOR >	
R857	1-247-872-11	CARBON	51K 5% 1/4W	R11	1-216-099-00	METAL CHIP 120K 5% 1/10W	
R858	1-247-872-11	CARBON	51K 5% 1/4W	R12	1-216-025-00	METAL CHIP 100 5% 1/10W	
R859	1-249-405-11	CARBON	100 5% 1/4W	R13	1-216-100-00	METAL GLAZE 130K 5% 1/10W	
R860	1-249-405-11	CARBON	100 5% 1/4W	R14	1-216-067-00	METAL CHIP 5. 6K 5% 1/10W	
R870	1-249-451-11	CARBON	2. 2 5% 1/4W	R21	1-216-099-00	METAL CHIP 120K 5% 1/10W	
R871	1-249-451-11	CARBON	2. 2 5% 1/4W				
		< VARIABLE RESISTOR >					
RV101	1-241-630-11	RES, ADJ, CARBON 10K					
RV201	1-241-630-11	RES, ADJ, CARBON 10K					

MD-A

MD-HX

Ref. No.	Part No.	Description	Remark		
R23	1-216-100-00	METAL GLAZE	130K	5%	1/10W
R24	1-216-067-00	METAL CHIP	5.6K	5%	1/10W
R31	1-216-033-00	METAL CHIP	220	5%	1/10W
R32	1-216-033-00	METAL CHIP	220	5%	1/10W
R71	1-216-082-00	METAL GLAZE	24K	5%	1/10W
R72	1-216-081-00	METAL CHIP	22K	5%	1/10W
R73	1-216-089-00	METAL CHIP	47K	5%	1/10W
R74	1-216-089-00	METAL CHIP	47K	5%	1/10W
< VARIABLE RESISTOR >					
RV11	1-241-627-11	RES, ADJ, CARBON 1K			
RV21	1-241-627-11	RES, ADJ, CARBON 1K			
RV71	1-241-630-11	RES, ADJ, CARBON 10K			
RV72	1-241-630-11	RES, ADJ, CARBON 10K			

*	A-2006-401-A	MD-HX BOARD, COMPLETE			

< CAPACITOR >					
C11	1-163-131-00	CERAMIC CHIP	390PF	5%	50V
C12	1-136-157-00	FILM	0.022uF	5%	50V
C13	1-124-234-00	ELECT	22uF	20%	16V
C18	1-163-117-00	CERAMIC CHIP	100PF	5%	50V
C21	1-163-131-00	CERAMIC CHIP	390PF	5%	50V
C22	1-136-157-00	FILM	0.022uF	5%	50V
C23	1-124-234-00	ELECT	22uF	20%	16V
C28	1-163-117-00	CERAMIC CHIP	100PF	5%	50V
C31	1-124-234-00	ELECT	22uF	20%	16V
C32	1-124-234-00	ELECT	22uF	20%	16V
C33	1-124-234-00	ELECT	22uF	20%	16V
C51	1-164-161-11	CERAMIC CHIP	0.0022uF	10%	100V
C52	1-164-161-11	CERAMIC CHIP	0.0022uF	10%	100V
C53	1-163-019-00	CERAMIC CHIP	0.0068uF	10%	50V
C54	1-136-601-11	FILM	0.01uF	5%	630V
C56	1-164-505-11	CERAMIC CHIP	2.2uF		16V
C57	1-164-346-11	CERAMIC CHIP	1uF		16V
C71	1-164-346-11	CERAMIC CHIP	1uF		16V
C80	1-124-234-00	ELECT	22uF	20%	16V
C81	1-164-232-11	CERAMIC CHIP	0.01uF		50V
C82	1-136-157-00	FILM	0.022uF	5%	50V
C83	1-164-004-11	CERAMIC CHIP	0.1uF	10%	25V
C84	1-136-478-11	FILM	470PF	5%	630V
C85	1-136-433-11	FILM	100PF	5%	630V
C86	1-163-143-00	CERAMIC CHIP	0.0012uF	5%	50V
C87	1-136-273-91	FILM	75PF	5%	630V
C88	1-163-003-11	CERAMIC CHIP	330PF	10%	50V
C89	1-124-234-00	ELECT	22uF	20%	16V
C90	1-107-045-00	MICA	3.9PF		500V
C91	1-164-232-11	CERAMIC CHIP	0.01uF		50V

Ref. No.	Part No.	Description	Remark		
C92	1-136-157-00	FILM	0.022uF	5%	50V
C93	1-164-004-11	CERAMIC CHIP	0.1uF	10%	25V
C94	1-136-478-11	FILM	470PF	5%	630V
C95	1-136-433-11	FILM	100PF	5%	630V
C96	1-163-143-00	CERAMIC CHIP	0.0012uF	5%	50V
C97	1-136-273-91	FILM	75PF	5%	630V
C98	1-163-003-11	CERAMIC CHIP	330PF	10%	50V
C99	1-164-005-11	CERAMIC CHIP	0.47uF		25V
< CONNECTOR >					
*CNP31	1-580-782-11	CONNECTOR, BOARD TO BOARD			
*CNP32	1-580-781-11	PIN, CONNECTOR (PC BOARD) 7P			
*CNP33	1-580-782-11	CONNECTOR, BOARD TO BOARD			
*CNP71	1-564-719-11	PIN, CONNECTOR (SMALL TYPE) 3P			
*CNP72	1-580-411-11	SOCKET, CONNECTOR 4P			
< DIODE >					
D31	8-719-016-74	DIODE			1SS352
< IC >					
IC31	8-759-106-02	IC			uPC4570G2
IC81	8-759-106-56	IC			uPC1297CA
< COIL >					
L81	1-410-780-11	INDUCTOR			27mH
L91	1-410-780-11	INDUCTOR			27mH
< TRANSISTOR >					
Q51	8-729-808-01	TRANSISTOR			2SD1622-S
Q52	8-729-808-01	TRANSISTOR			2SD1622-S
Q53	8-729-808-01	TRANSISTOR			2SD1622-S
Q71	8-729-216-22	TRANSISTOR			2SA1162
< RESISTOR >					
R11	1-216-099-00	METAL CHIP	120K	5%	1/10W
R12	1-216-025-00	METAL CHIP	100	5%	1/10W
R13	1-216-100-00	METAL GLAZE	130K	5%	1/10W
R14	1-216-067-00	METAL CHIP	5.6K	5%	1/10W
R21	1-216-099-00	METAL CHIP	120K	5%	1/10W
R22	1-216-025-00	METAL CHIP	100	5%	1/10W
R22	1-216-025-00	METAL CHIP	100	5%	1/10W
R23	1-216-100-00	METAL GLAZE	130K	5%	1/10W
R24	1-216-067-00	METAL CHIP	5.6K	5%	1/10W
R31	1-216-033-00	METAL CHIP	220	5%	1/10W
R32	1-216-033-00	METAL CHIP	220	5%	1/10W
R51	1-216-097-00	METAL CHIP	100K	5%	1/10W
R52	1-216-097-00	METAL CHIP	100K	5%	1/10W
R53	1-216-073-00	METAL CHIP	10K	5%	1/10W
R54	1-216-309-00	METAL CHIP	5.6	5%	1/10W

MD-HX

PANEL

Ref. No.	Part No.	Description	Remark		
R55	1-216-309-00	METAL CHIP	5.6	5%	1/10W
R57	1-216-298-00	METAL CHIP	2.2	5%	1/10W
R71	1-216-082-00	METAL GLAZE	24K	5%	1/10W
R72	1-216-081-00	METAL CHIP	22K	5%	1/10W
R73	1-216-089-00	METAL CHIP	47K	5%	1/10W
R74	1-216-089-00	METAL CHIP	47K	5%	1/10W
R81	1-216-073-00	METAL CHIP	10K	5%	1/10W
R82	1-216-085-00	METAL CHIP	33K	5%	1/10W
R83	1-216-001-00	METAL CHIP	10	5%	1/10W
R84	1-216-101-00	METAL CHIP	150K	5%	1/10W
R85	1-216-075-00	METAL CHIP	12K	5%	1/10W
R91	1-216-073-00	METAL CHIP	10K	5%	1/10W
R92	1-216-085-00	METAL CHIP	33K	5%	1/10W
R93	1-216-001-00	METAL CHIP	10	5%	1/10W
R94	1-216-101-00	METAL CHIP	150K	5%	1/10W
R95	1-216-075-00	METAL CHIP	12K	5%	1/10W
< VARIABLE RESISTOR >					
RV11	1-241-627-11	RES, ADJ, CARBON 1K			
RV21	1-241-627-11	RES, ADJ, CARBON 1K			
RV71	1-241-630-11	RES, ADJ, CARBON 10K			
RV72	1-241-630-11	RES, ADJ, CARBON 10K			
RV81	1-241-122-11	RES, ADJ, CARBON 22K			
RV91	1-241-122-11	RES, ADJ, CARBON 22K			
< RELAY >					
RY31	1-515-726-11	RELAY			
< TRANSFORMER >					
T51	1-406-417-11	COIL, BIAS OSCILLATION			
T81	1-433-381-11	TRANSFORMER, BIAS OSCILLATOR			
T91	1-433-381-11	TRANSFORMER, BIAS OSCILLATOR			
< TEST PIN >					
*TP81	1-568-449-11	HOUSING, CONNECTOR(PC BOARD)3P			

*	A-2006-797-A	PANEL BOARD, COMPLETE			

*	3-362-478-21	HOLDER (T), LED			
*	4-921-941-01	CUSHION (FL)			
*	4-933-646-01	HOLDER (TC), FL TUBE			
< CAPACITOR >					
C406	1-162-292-31	CERAMIC	680PF	10%	50V
C407	1-162-292-31	CERAMIC	680PF	10%	50V
C408	1-162-292-31	CERAMIC	680PF	10%	50V
C901	1-161-379-00	CERAMIC	0.01uF	20%	25V

Ref. No.	Part No.	Description	Remark		
C902	1-161-379-00	CERAMIC	0.01uF	20%	25V
< CONNECTOR >					
*CN901	1-568-836-11	SOCKET, CONNECTOR 17P			
< DIODE >					
D901	8-719-301-38	LED	SEL2210S-C (C FADE)		
D902	8-719-301-38	LED	SEL2210S-C (FADE)		
D903	8-719-301-38	LED	SEL2210S-C (EDIT)		
D904	8-719-301-38	LED	SEL2210S-C (REC LEVEL)		
D906	8-719-987-63	DIODE	1N4148M		
< FILTER >					
FL901	1-519-741-11	INDICATOR TUBE, FLUORESCENT			
< IC >					
IC901	8-759-321-92	IC	HD614022S		
< TRANSISTOR >					
Q901	8-729-900-61	TRANSISTOR	DTA114ES		
< RESISTOR >					
R401	1-249-405-11	CARBON	100	5%	1/4W
R402	1-249-405-11	CARBON	100	5%	1/4W
R403	1-249-405-11	CARBON	100	5%	1/4W
R901	1-249-407-11	CARBON	150	5%	1/4W
R902	1-249-409-11	CARBON	220	5%	1/4W
R904	1-249-413-11	CARBON	470	5%	1/4W
R905	1-249-415-11	CARBON	680	5%	1/4W
R906	1-249-417-11	CARBON	1K	5%	1/4W
R907	1-249-420-11	CARBON	1.8K	5%	1/4W
R909	1-249-407-11	CARBON	150	5%	1/4W
R910	1-249-409-11	CARBON	220	5%	1/4W
R911	1-249-411-11	CARBON	330	5%	1/4W
R912	1-249-418-11	CARBON	1.2K	5%	1/4W
R927	1-249-411-11	CARBON	330	5%	1/4W
R928	1-249-411-11	CARBON	330	5%	1/4W
R929	1-249-411-11	CARBON	330	5%	1/4W
R930	1-249-411-11	CARBON	330	5%	1/4W
R931	1-247-903-00	CARBON	1M	5%	1/4W
R932	1-249-411-11	CARBON	330	5%	1/4W
< SWITCH >					
S901	1-554-303-21	SWITCH, TACTILE (HIGH SPEED)			
S902	1-554-303-21	SWITCH, TACTILE (NORMAL SPEED)			
S905	1-554-303-21	SWITCH, TACTILE (RESET)			
S906	1-554-303-21	SWITCH, TACTILE (MEMORY)			
S907	1-554-303-21	SWITCH, TACTILE (A/B)			

PANEL

REC VOL

SW-A

SW-B

Ref. No.	Part No.	Description	Remark
S909	1-554-303-21	SWITCH, TACTILE (C FADE)	
S910	1-554-303-21	SWITCH, TACTILE (FADE)	
S911	1-554-303-21	SWITCH, TACTILE (EDIT)	
S912	1-554-303-21	SWITCH, TACTILE (TIME)	
< VIBRATOR >			
X901	1-567-775-11	VIBRATOR, CERAMIC 4.19MHz	

*	1-643-528-11	REC VOL BOARD	

< CAPACITOR >			
C814	1-164-159-11	CERAMIC 0.1uF	50V
< CONNECTOR >			
*CN508	1-568-832-11	SOCKET, CONNECTOR 13P	
< DIODE >			
D805	8-719-987-63	DIODE 1N4148M	
D806	8-719-987-63	DIODE 1N4148M	
< IC >			
IC806	8-759-820-62	IC LB1639	
< TRANSISTOR >			
Q807	8-729-900-65	TRANSISTOR DTA144ES	
Q808	8-729-900-89	TRANSISTOR DTC144ES	
< RESISTOR >			
R125	1-249-435-11	CARBON 33K 5%	1/4W
R225	1-249-435-11	CARBON 33K 5%	1/4W
R832	1-249-412-11	CARBON 390 5%	1/4W
R833	1-249-411-11	CARBON 330 5%	1/4W
< VARIABLE RESISTOR >			
RV301	1-241-891-11	RES, VAR, CARBON 20KX3 (REC REVEL)	

*	1-634-841-14	SW-A BOARD	

	3-343-419-01	HOLDER (S SENSER A)	
< CONNECTOR >			
*CNP81	1-568-852-11	SOCKET, CONNECTOR 9P	

Ref. No.	Part No.	Description	Remark
< IC >			
IC81	8-719-710-03	DIODE	NJL5165K-B
< RESISTOR >			
R84	1-249-417-11	CARBON 1K 5%	1/4W
R85	1-249-408-11	CARBON 180 5%	1/4W
< SWITCH >			
S81	1-571-958-11	SWITCH, PUSH (1 KEY) (STOP)	
S82	1-571-281-21	SWITCH, LEAF (70EQ)	
S86	1-571-281-21	SWITCH, LEAF (HALF)	

*	1-634-841-14	SW-B BOARD	

	3-343-419-01	HOLDER (S SENSER A)	
< CONNECTOR >			
*CNP81	1-568-852-11	SOCKET, CONNECTOR 9P	
< IC >			
IC81	8-719-710-03	DIODE	NJL5165K-B
< RESISTOR >			
R81	1-249-414-11	CARBON 560 5%	1/4W
R82	1-247-818-11	CARBON 300 5%	1/4W
R83	1-247-834-11	CARBON 1.3K 5%	1/4W
R84	1-249-417-11	CARBON 1K 5%	1/4W
R85	1-249-408-11	CARBON 180 5%	1/4W
< SWITCH >			
S81	1-571-958-11	SWITCH, PUSH (1 KEY) (STOP)	
S82	1-571-281-21	SWITCH, LEAF (70EQ)	
S83	1-571-281-21	SWITCH, LEAF (METAL)	
S84	1-571-281-21	SWITCH, LEAF (REC A)	
S85	1-571-281-21	SWITCH, LEAF (REC B)	
S86	1-571-281-21	SWITCH, LEAF (HALF)	

MISCELLANEOUS			

* 5	1-574-726-11	WIRE, FLAT TYPE (13 CORE)	
6	1-690-907-11	WIRE (FLAT TYPE) (17 CORE)	
69	1-690-906-11	WIRE (FLAT TYPE) (9 CORE)	
* 120	1-634-841-14	SW-A BOARD (DECK A)	
* 120	1-634-841-14	SW-B BOARD (DECK B)	
HP901	A-2003-837-A	BASE ASSY, HEAD (PB) (DECK A)	

Ref.No.	Part No.	Description	Remark
	HRPE901A-2003-838-A	BASE ASSY, HEAD (PB/REC/ERASE)	(DECK B)
M901A	X-3359-417-1	MOTOR ASSY (CAPSTAN)	(DECK A)
M901B	X-3359-417-1	MOTOR ASSY (CAPSTAN)	(DECK B)
M902A	X-3363-501-1	MOTOR ASSY (REEL)	(DECK A)
M902B	X-3363-501-1	MOTOR ASSY (REEL)	(DECK B)

ACCESSORIES & PACKING MATERIALS

- * 3-350-154-01 CUSHION
- * 3-704-350-01 SHEET (STANDARD), PROTECTION

HARDWARE LIST

- #1 7-685-646-79 SCREW +BVTP 3X8 TYPE2 N-S
- #2 7-621-773-93 SCREW (PANEL 2.6 TP2)
- #3 7-685-645-79 SCREW +BVTP 3X6 TYPE2 N-S
- #4 7-621-775-00 SCREW +B 2.6X3
- #5 7-627-556-08 SCREW +P 2.6X2.8

