

TC-D905

SERVICE MANUAL

AEP Model
UK Model
E Model



SPECIFICATIONS

Recording system 4-track 2-channel stereo
Fast-forward and rewind time
Approx. 90 sec. (with C-60 cassette)
Bias AC Bias
Signal-to-noise ratio (NAB, at peak level)

Cassette	Dolby NR switch		
	OFF	B-TYPE ON	C-TYPE ON
TYPE IV (Sony METAL-ES)	58 dB	65 dB	71 dB
TYPE II (Sony UX-S)	57 dB	64 dB	70 dB
TYPE I (Sony HF-S)	54 dB	61 dB	67 dB

Total harmonic distortion
1.0% (with Sony METAL-ES cassettes)

Frequency response (DOLBY NR OFF)

TYPE IV cassette (Sony METAL-ES)	30 – 15,000 Hz (± 3 dB)
TYPE II cassette (Sony UX-S)	30 – 14,000 Hz (± 3 dB)
TYPE I cassette (Sony HF-S)	30 – 13,000 Hz (± 3 dB)

Wow and flutter $\pm 0.18\%$ (DIN)

Inputs

Line inputs (phono jacks)	Sensitivity	77.5 mV (-20 dB)
	Input impedance	50 k ohms

Model Name Using Similar Mechanism	NEW
Tape Transport Mechanism Type	DECK A TCM-190RA11
	DECK B TCM-190RB13

Outputs

Line outputs (phono jacks)	Rated output level	0.44 V (-5 dB) at a load impedance 47 k ohms
	Load impedance	Over 10 k ohms

General

Power requirements

AEP, G model: 220–230 V AC, 50/60 Hz
UK model: 240 V AC, 50/60 Hz
Saudi Arabia, E model: 120,220,240 V AC, 50/60 Hz

Power consumption

25 watts

Dimensions

Approx. 355 × 134.5 × 310 mm (w/h/d) including projecting parts and controls

Weight

Approx. 4.5 kg

Supplied accessory

Audio connecting cord (2)

Design and specifications subject to change without notice.

Note

This appliance conforms with EEC Directive 87/308/EEC regarding interference suppression.

STEREO CASSETTE DECK
SONY[®]



TABLE OF CONTENTS

<u>Section</u>	<u>Title</u>	<u>Page</u>
Specifications		1
Service Note		2
Model Identification		2
SECTION 1. GENERAL		
1-1. Location of Controls		3
SECTION 2. DISASSEMBLY		
2-1. Front Panel Assembly		4
2-2. Mechanism Deck		4
SECTION 3. ADJUSTMENTS		
3-1. Mechanical Adjustments		5
3-2. Electrical Adjustments		5
SECTION 4. DIAGRAMS		
4-1. Circuit Board Location		8
4-2. Semiconductor Lead Layouts		8
4-3. Printed Wiring Boards (Main Section)		10
4-4. Schematic Diagram (Main Section)		15
4-5. Schematic Diagram (Panel Section)		19
4-6. Printed Wiring Boards (Panel Section)		23
SECTION 5. EXPLODED VIEWS		
5-1. Chassis Section		25
5-2. Front Panel Section		26
5-3. Mechanism Deck Section (1)		27
5-4. Mechanism Deck Section (2)		28
SECTION 6. ELECTRICAL PARTS LIST		
		29

SERVICING NOTE



Flexible Circuit Board Repairing

- Keep the temperature of the soldering iron around 270°C during repairing.
- Do not touch the soldering iron on the same conductor of the circuit board (within 3 times).
- Be careful not to apply force on the conductor when soldering or unsoldering.

Notes on chip component replacement

- Never reuse a disconnected chip component.
- Notice that the minus side of a tantalum capacitor may be damaged by heat.

SAFETY-RELATED COMPONENT WARNING!!

COMPONENTS IDENTIFIED BY MARK  OR DOTTED LINE WITH MARK  ON THE SCHEMATIC DIAGRAMS AND IN THE PARTS LIST ARE CRITICAL TO SAFE OPERATION. REPLACE THESE COMPONENTS WITH SONY PARTS WHOSE PART NUMBERS APPEAR AS SHOWN IN THIS MANUAL OR IN SUPPLEMENTS PUBLISHED BY SONY.

MODEL IDENTIFICATION

—Specification Label—

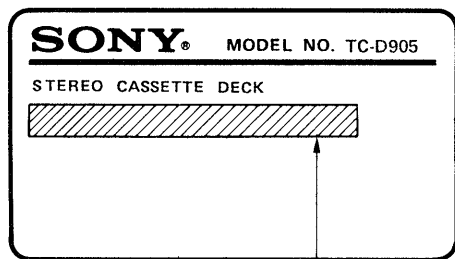

AEP, G model: AC: 220—230V ~ 50/60Hz
 UK model: AC: 240V ~ 50/60Hz
 Saudi Arabia, E model: AC: 120V, 220V, 240V ~ 50/60Hz 25W

SECTION 1 GENERAL

This section is extracted from instruction manual.

1-1. LOCATION OF CONTROLS

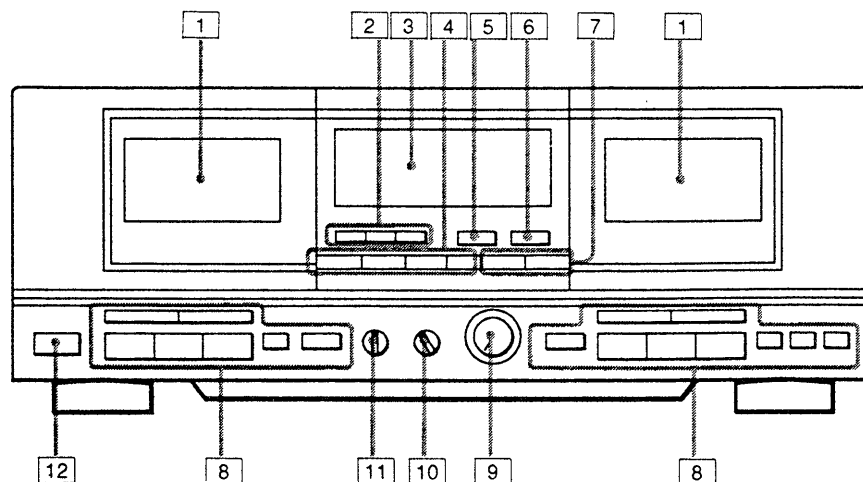

- | | |
|--|--|
| <p>1 Cassette holders</p> <p>2 COUNTER buttons 13, 15</p> <p>3 Display window</p> <p>4 AUTO CD SYNCRO REC buttons and indicators
C.FADE button and indicator 37
FADE button and indicator 35
EDIT button and indicator 41
TIME SET button 41</p> <p>5 ARL (automatic recording level) button and indicator 20</p> <p>6 FADER button 22</p> <p>7 SYNCRO (synchronized) DUBBING buttons 27</p> <p>8 Tape operation buttons
◀◀ Leftward fast winding/AMS* 8, 12
▶▶ Rightward fast winding/AMS* 8, 12
◀ Reverse play
▶ Forward play
▲ Ejection
■ Stop
 PAUSE
○ REC MUTE Record muting (deck B only) 24
● REC Recording (deck B only)</p> | <p>9 REC (recording) LEVEL control 16</p> <p>10 DOLBY NR switch 8, 16, 35, 37, 41</p> <p>11 DIRECTION MODE switch 8, 16, 35, 37, 40</p> <p>12 POWER switch</p> |
|--|--|

* AMS is the abbreviation for Automatic Music Sensor.

SECTION 2 DISASSEMBLY

2-1. FRONT PANEL ASSEMBLY

- ① Remove the connector from MAIN board.

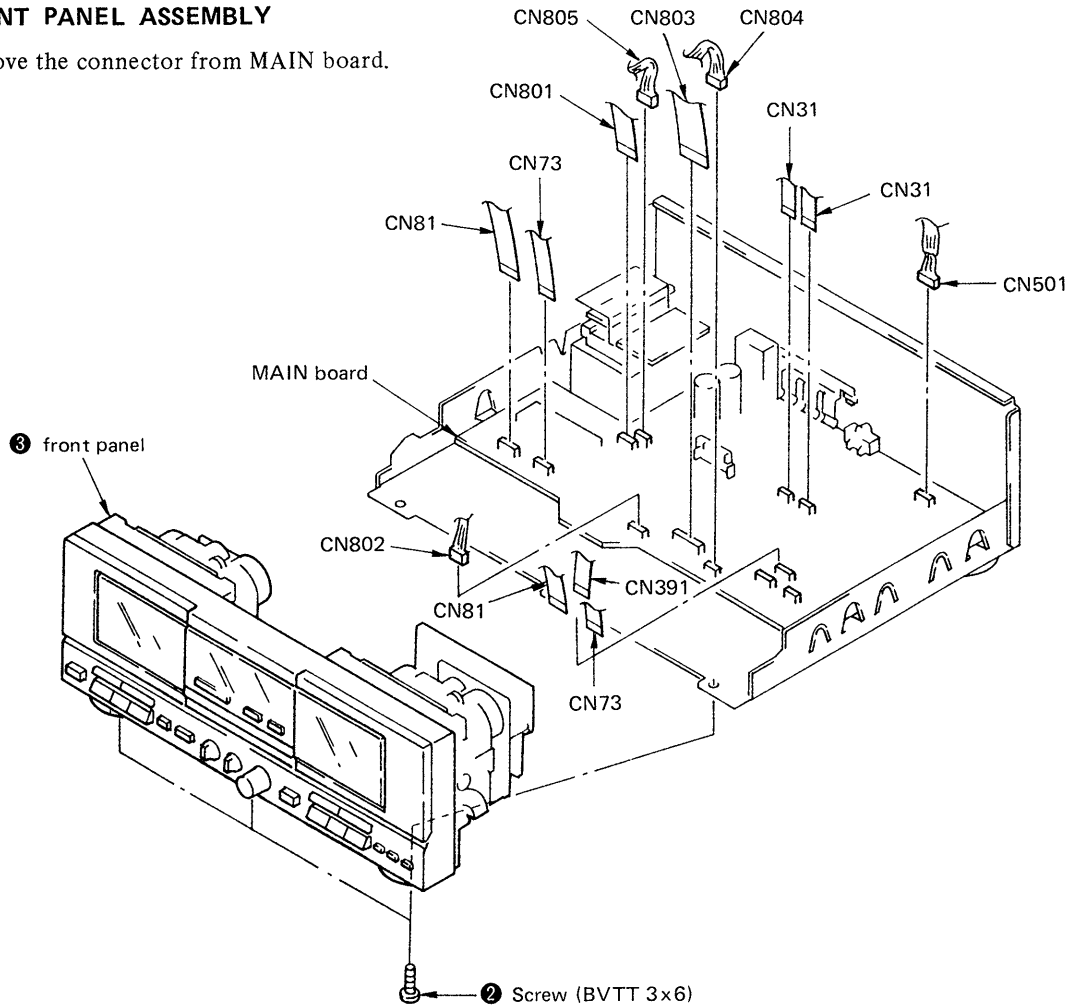

2-2. MECHANISM DECK

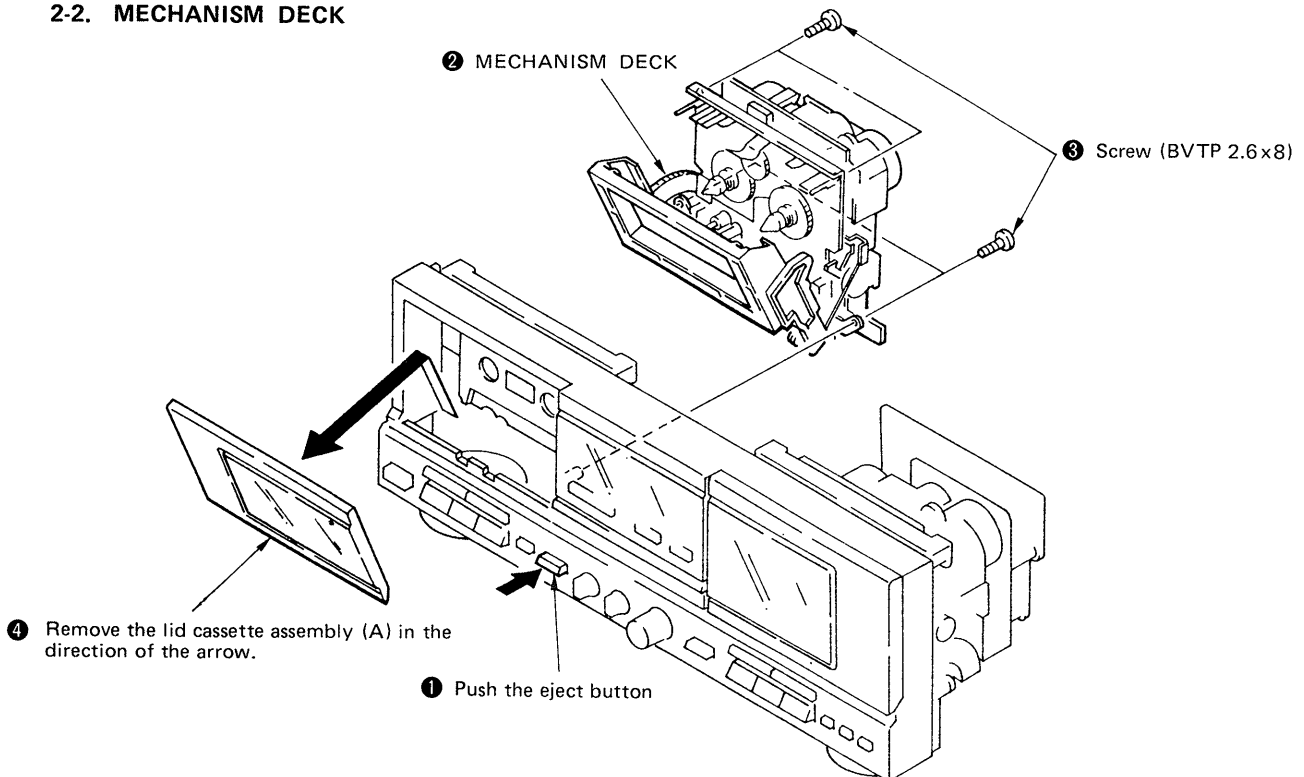

SECTION 3 ADJUSTMENTS

3-1. MECHANICAL ADJUSTMENTS PRECAUTIONS

- Clean the following parts with a denatured alcohol-moistened swab :

record/playback head	pinch roller
erase head	rubber belts
capstan	idlers
- Demagnetize the record/playback head with a head demagnetizer.
(Head demagnetizer do not approach for the erase head.)
- Do not use a magnetized screwdriver for the adjustment.
- After the adjustments, apply suitable locking compound to the parts adjusted.
- The adjustments should be performed with the rated power supply voltage unless otherwise noted.

Torque Measurement

Torque	Torque meter	Meter reading
FWD	CQ-102C	35 to 60g·cm (0.49 to 0.83 oz·inch)
FWD Back tension	CQ-102C	2 to 6g·cm (0.028 to 0.084 oz·inch)
Reverse	CQ-102RB	35 to 60g·cm (0.49 to 0.83 oz·inch)
Reverse Back tension	CQ-102RB	2 to 6g·cm (0.028 to 0.084 oz·inch)
FF, REW	CQ-201B	70 to 110g·cm (0.98 to 1.52 oz·inch)

3-2. ELECTRICAL ADJUSTMENTS PRECAUTIONS

- The adjustment should be performed in the publication.
(Be sure to make playback adjustment at first.)
- The adjustment and measurement should be performed for both L-CH and R-CH.
 - Switch position
DOLBY NR switch : OFF
DIR MODE switch : ⇌
 - Standard record position
Deliver the standard input signal level to input jack and set the REC LEVEL control to obtain the standard output signal level as follows.

—Record Mode—

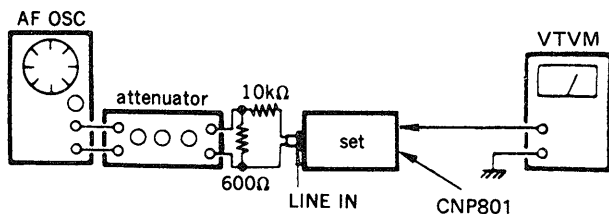

Standard Input Level

Input terminal	LINE IN
source impedance	10kΩ
input signal level	0.25V (-10dB)

Standard Output Level

Output terminal	LINE OUT
load impedance	47kΩ
output signal level	0.44V (-5dB)

Test Tape

Tape	Contents	Use
P-4-A100	10kHz, -10dB	Azimuth Adjustment
P-4-L300	315Hz, 0dB	Level Adjustment
WS-48B	3kHz, 0dB	Tape Speed Adjustment

- Prepare to electrical adjustments.
Short the connector TP801.

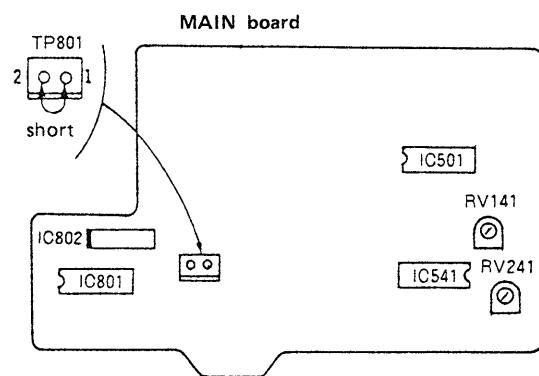

Record/Playback Head Azimuth Adjustment

DECK A DECK B

Procedure :

- FWD Playback Mode
test tape
P-4-A100
(10kHz, -10dB)

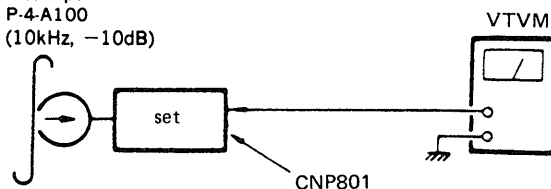

- Turn the adjustment screw for the maximum output levels. If these levels do not match, turn the adjustment screw until both of output levels match together within 1dB.

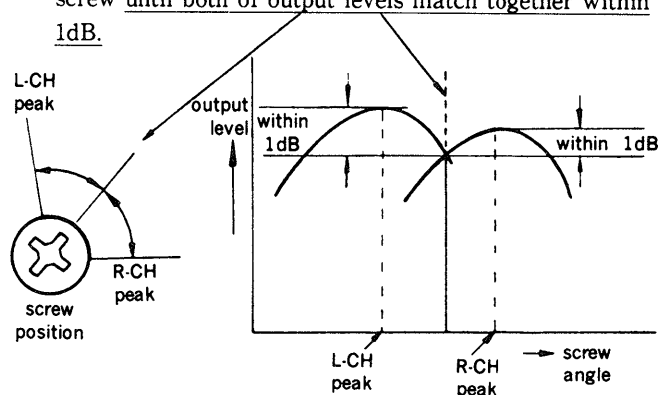

3. Playback Mode

test tape
P-4-A100
(10kHz, -10dB)

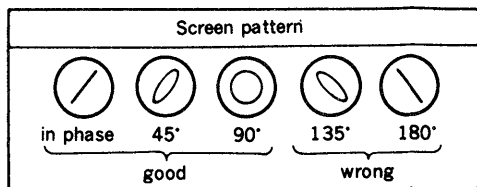
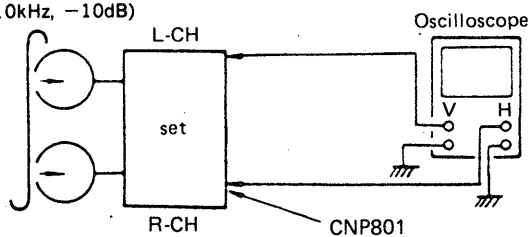

- Change the reverse playback mode and repeat the steps 1 to 3.
- After the adjustment, lock the adjustment screw with suitable locking compound.

Adjustment Location : record/playback head

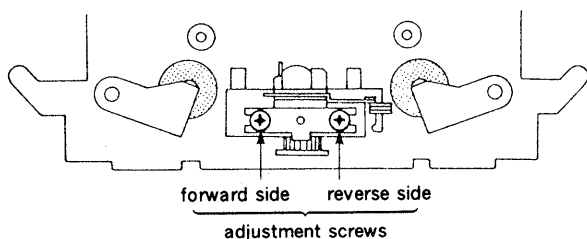

Tape Speed Adjustment DECK A DECK B

Procedure :

— FWD Playback Mode —

test tape
WS-48B
(3kHz, 0dB)

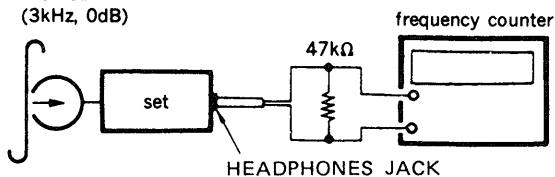

Perform high speed adjustment before normal speed adjustment.

(high speed adjustment)

- Keep on pressing the HIGH SPEED DUBBING switch.
- Adjust RV72 so that the frequency counter reading becomes $6,000 \pm 30$ Hz.
- Change to the Reverse playback mode and then repeat step 1 - 3.

(normal speed adjustment)

- Keep on pressing the NORMAL SPEED switch.
- Adjust RV71 so that the frequency counter reading becomes $3,000 \pm 15$ Hz.

Frequency difference between deck A and deck B the beginning of the tape should be within 1.5%.

Adjustment Location : MD-A, MD-D board

Playback Level Adjustment DECK A DECK B

Procedure :

— FWD Playback Mode —

test tape
P-4-L300
(315kHz, 0dB)

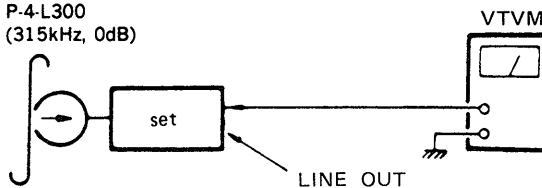

Adjust deck A/B: RV11 (L-CH), RV21 (R-CH) so that the VTVM reading becomes the adjustment limits below.

Adjustment Limits :

LINE OUT level: -15 ± 0.5 dB (0.130 ~ 0.146 V)

Level Difference between Channels: within 0.5 dB

Confirm the LINE OUT level does not change in playback mode while changing the mode from playback to stop several times.

Adjustment Location : MD-A, MD-D board

Record Bias Adjustment DECK B

Setting :

REC LEVEL control: standard record position (Refer to page 5.)

Procedure :

- Record Mode

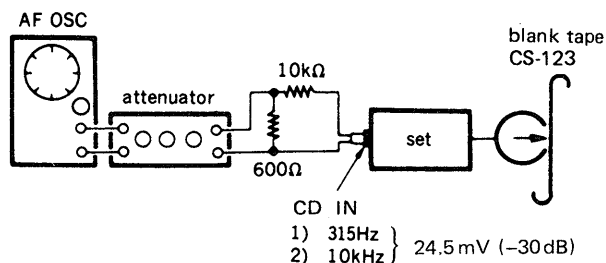

2. Playback Mode

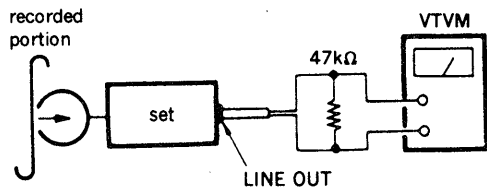

Playback the signal recorded in step 1.
 Confirm that the 10kHz playback output is $0 \pm 0.5\text{dB}$ relative to the 315Hz output. If necessary, adjust RV391 (L-CH) RV491 (R-CH) and repeat the steps given above.

Adjustment Location: HX-PRO board

Record Level Adjustment DECK B

Setting:

REC LEVEL control: standard record position (Refer to page 5.)

Procedure:

1. Record Mode

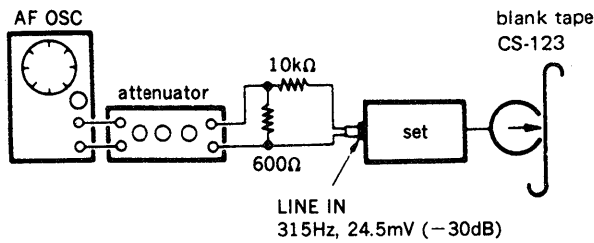

2. Playback Mode

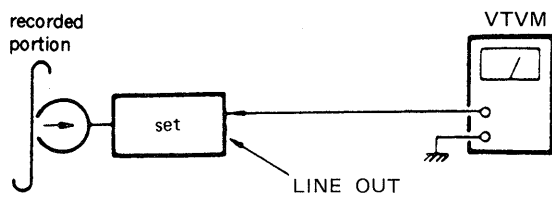

Confirm playback the tape recorded become adjustment level as follows.

If necessary, adjust RV141 (L-CH), RV241 (R-CH) and repeat steps 1 and 2.

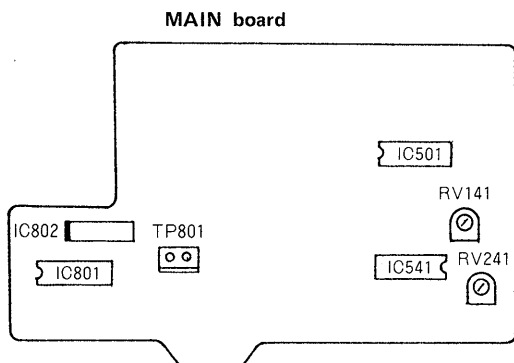

Adjustment Limits:

LINE OUT level: $-25 \pm 0.5\text{ dB}$ (42 ~ 46 mV)

Adjustment Location: MAIN board

—Adjustment Parts Location Diagrams—

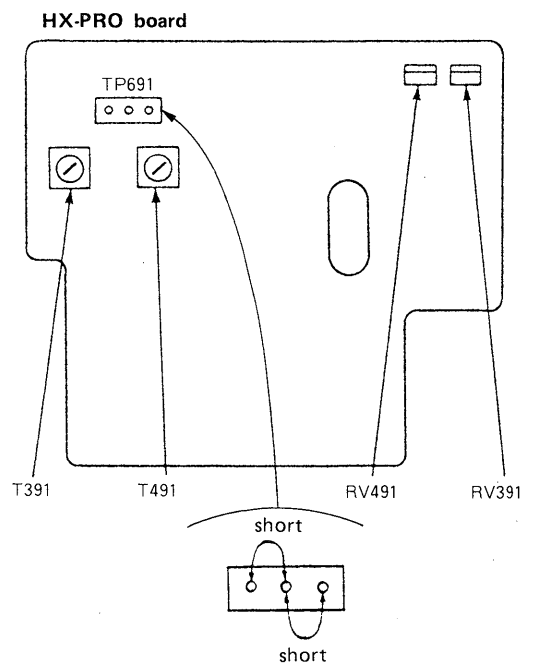
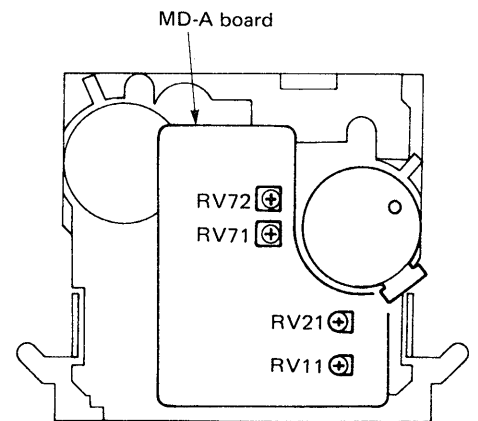
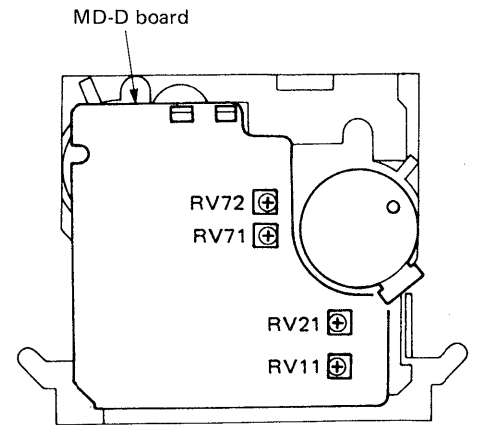

Note: After adjustment replace the short on TP691.

SECTION 4 DIAGRAMS

4-1. CIRCUIT BOARD LOCATION

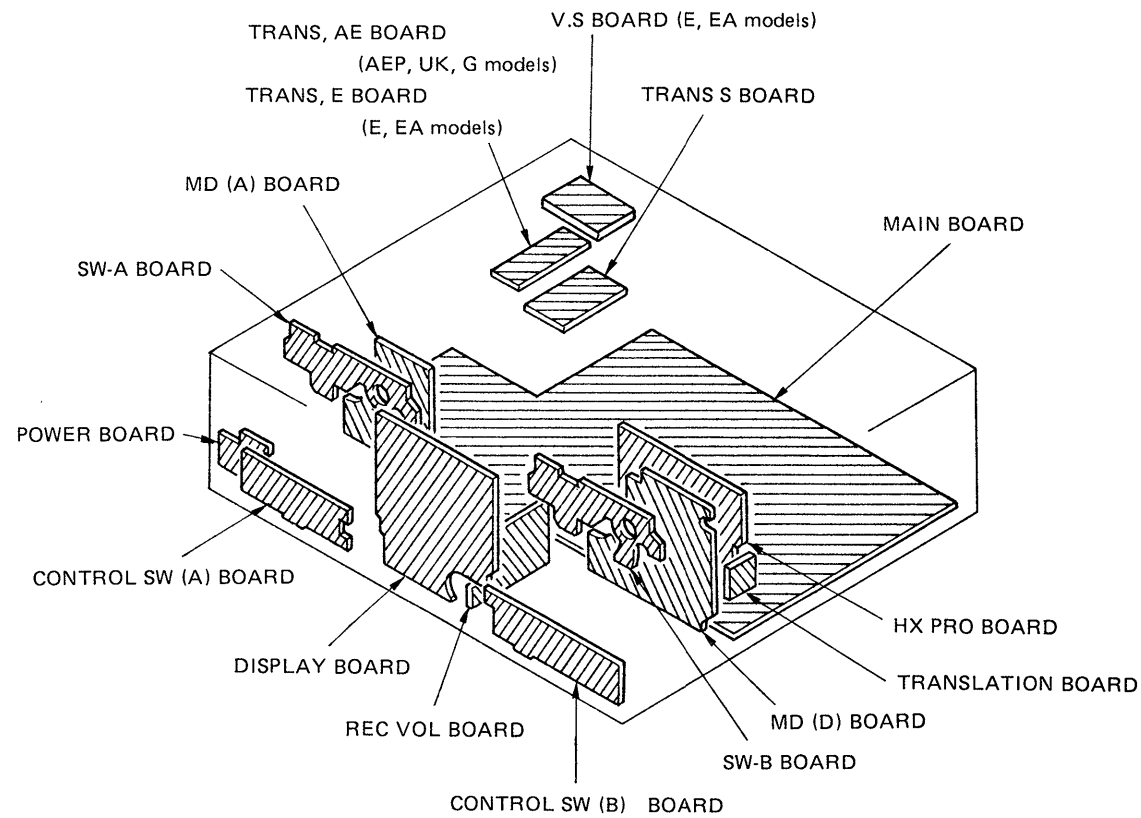

4-2. SEMICONDUCTOR LEAD LAYOUTS

BA6208

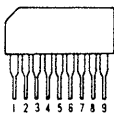

DTA114ES
DTA144ES
DTC114ES
DTC143ES
DTC144ES
2SC2603EF



HZS6A1L
HZS6B3L
HZS9A2L
1SS120
1SS202-1

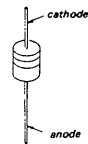

SEL2210S-D

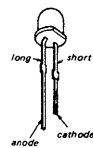

2SB1370-EF
2SD1312-K

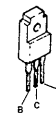

TA7272P

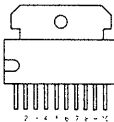

2SA1317-S
2SA1175-HFE

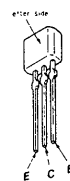

10E2N

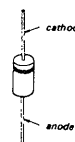

NJL5165K-B

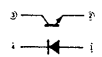
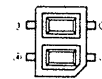

2SC3623A-LK



2SB1116-K
2SB1-13-4



4-3. PRINTED WIRING BOARDS
 -MAIN SECTION-
 ● See page 8 for semiconductor lead layouts.

● Semiconductor Location

Ref. No.	Location	Ref. No.	Location
D31	I-28	Q51	H-28
D161	B-10	Q52	H-28
D261	C-10	Q71 (DECK A)	D-28
D501	D-12	Q71 (DECK B)	H-27
D571	C-15	Q101	C-13
D661	G-12	Q131	D-14
D662	G-13	Q201	C-14
D701	D-19	Q231	E-14
D702	D-19	Q501	F-12
D703	C-19	Q502	C-12
D704	C-19	Q503	D-12
D706	D-18	Q551	C-12
D707	C-18	Q552	C-13
D709	B-16	Q571	D-15
D712	D-19	Q572	C-15
D713	D-19	Q602	H-11
D714	D-19	Q603	H-11
D715	E-19	Q605	H-11
D716	E-18	Q661	G-13
D717	E-18	Q662	G-13
D718	E-19	Q663	G-13
D801	G-22	Q665	F-12
D802	I-21	Q666	G-12
D803	I-22	Q667	G-12
D804	I-22	Q668	G-12
D805	B-19	Q669	G-14
D861	E-17	Q670	G-14
D862	E-16	Q671	G-14
D863	H-15	Q672	G-13
D864	I-11	Q701	B-17
		Q702	C-18
		Q703	B-15
IC31 (DECKA)	F-27	Q704	B-15
IC31 (DECKB)	J-26	Q707	E-18
IC81	B-29	Q708	E-19
IC82	B-27	Q709	B-16
IC501	E-11	Q710	D-17
IC502	C-13	Q801	G-21
IC531	E-14	Q802	G-22
IC541	G-11	Q803	G-22
IC551	C-14	Q804	G-22
IC561	C-10	Q806	G-22
IC571	D-16	Q808	G-20
IC681	G-13	Q809	H-21
IC691	C-23	Q810	I-20
IC701	C-18	Q811	H-20
IC801	H-21	Q861	G-16
IC802	G-20	Q862	G-16
IC861	F-17	Q863	H-16
IC862	G-17	Q864	H-16
IC863	G-15		

Note:
 ● ○ : parts extracted from the component side.
 ● Abbreviation
 G: Germany model
 EA: Saudi Arabia model

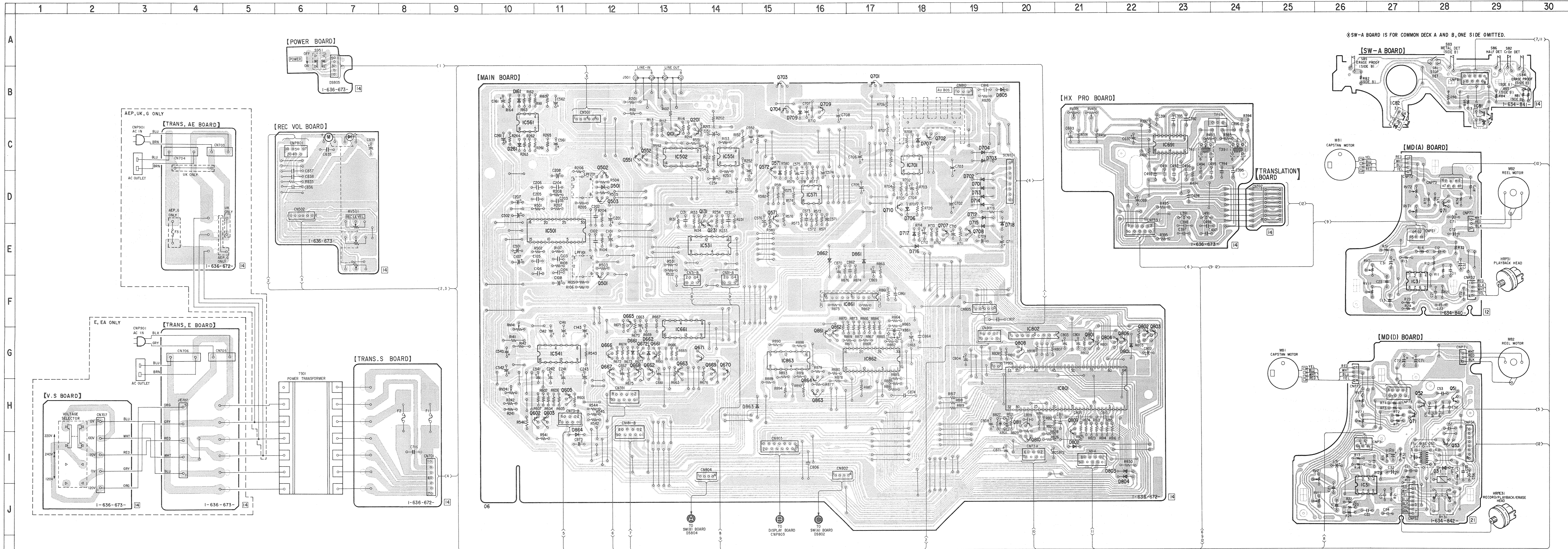

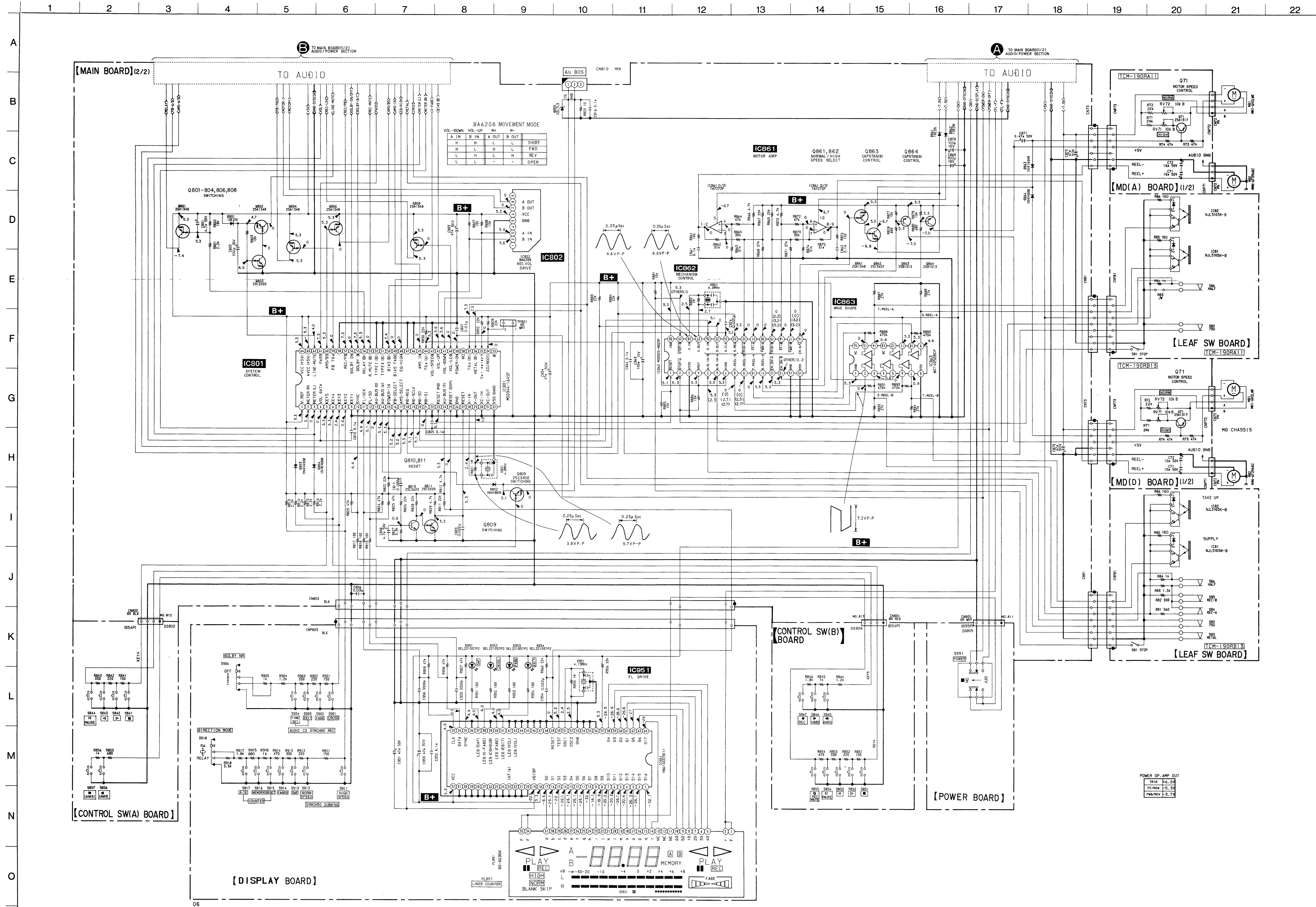

Note:

- All capacitors are in μF unless otherwise noted. pF : μF 50WV or less are not indicated except for electrolytics and tantalums.
- All resistors are in Ω and $1/4\text{W}$ or less unless otherwise specified.

Note: The components identified by mark Δ or dotted line with mark Δ are critical for safety. Replace only with part number specified.

- \bullet B+ : B+ line.
- \bullet B- : B- line.
- \square : adjustment for repair.
- \ast : selected to yield optimum performance.
- Voltage and waveforms are dc with respect to ground under no-signal (detuned) conditions.
- no mark: STOP
- (): \blacktriangleright
- < >: \blacktriangleleft
- []: REV

- Voltagess are taken with a VOM. (Input impedance $10\text{M}\Omega$) Voltage variations may be noted due to normal production tolerances.
- Abbreviation
G: Germany model
EA: Saudi Arabia model

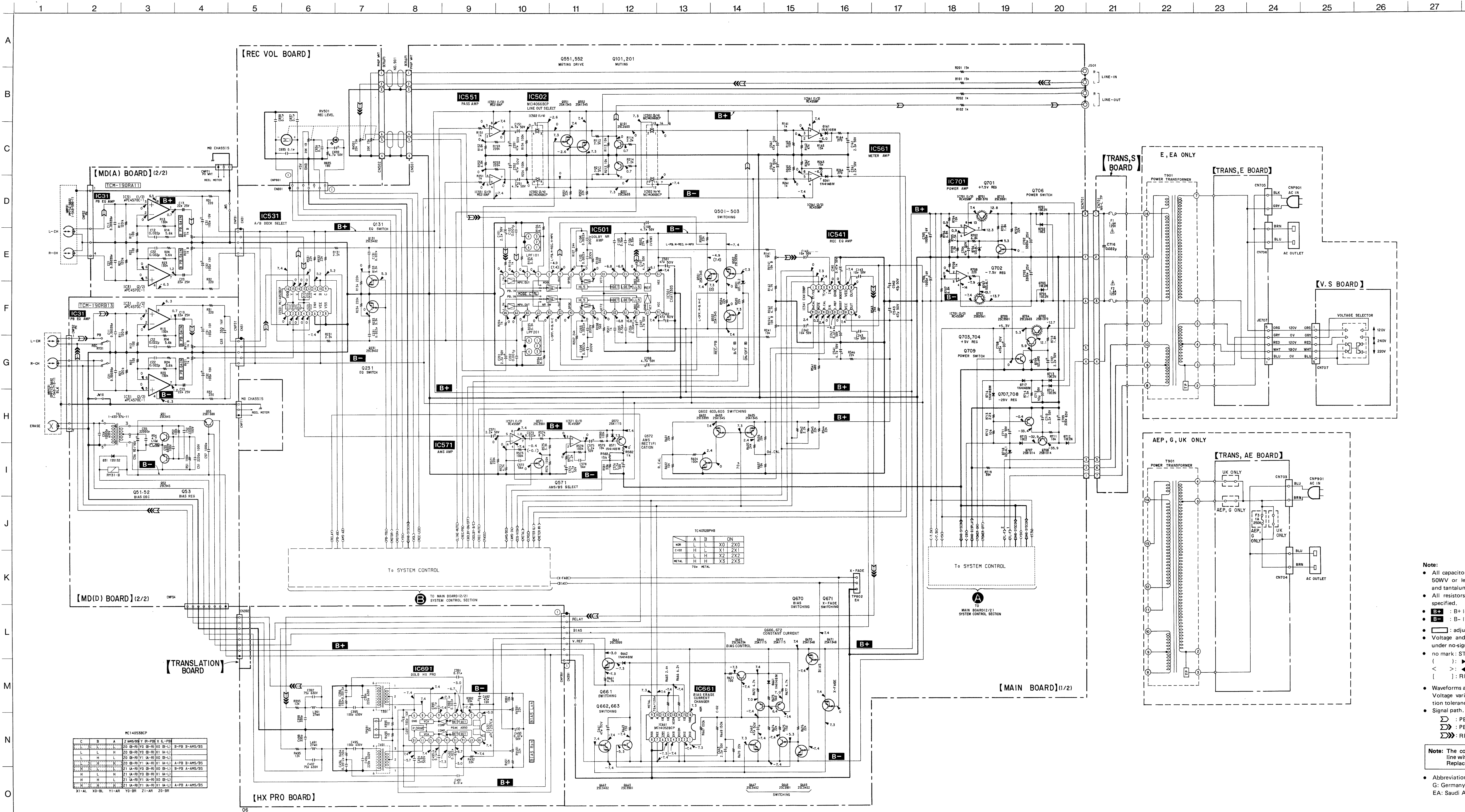

Note:

- All capacitors are in μF unless otherwise noted. pF : μpF 50WV or less are not indicated except for electrolytics and tantalums.
- All resistors are in Ω and $\frac{1}{2}\text{W}$ or less unless otherwise specified.
- B+**: B+ line.
- B-**: B- line.
- \square : adjustment for repair.
- Voltage and waveforms are dc with respect to ground under no-signal (detuned) conditions.
- no mark: STOP
- (): \blacktriangleleft
- < : \blacktriangleright
- []: REV
- Waveforms are taken with an oscilloscope. Voltage variations may be noted due to normal production tolerances.
- Signal path.
- \curvearrowright : PB (DECK A)
- \curvearrowleft : PB (DECK B)
- \curvearrowright : REC (DECK B)

Note: The components identified with mark \triangle or dotted line with mark \triangle are critical for safety. Replace only with part number specified.

- Abbreviation
- G: Germany model
- EA: Saudi Arabia model

4-6. PRINTED WIRING BOARDS —PANEL SECTION—

• See page 8 for semiconductor lead layouts.

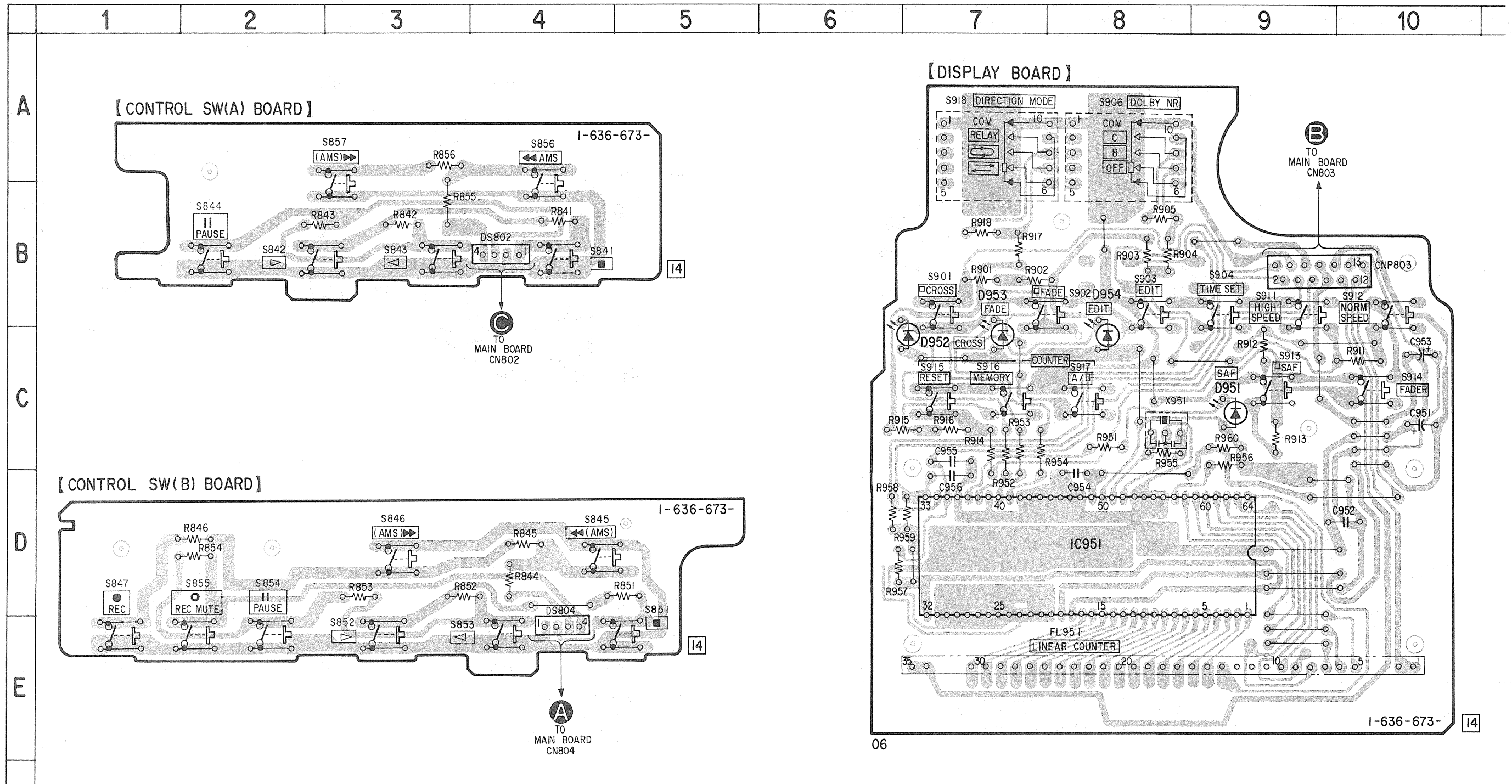

Note:

• ○ — : parts extracted from the component side.

• Abbreviation

G: Germany model

EA: Saudi Arabia model

SECTION 5 EXPLODED VIEWS

NOTE:

- -XX, -X mean standardized parts, so they may have some differences from the original one.
- Color Indication of Appearance Parts
Example:
KNOB, BALANCE (WHITE) ... (RED)

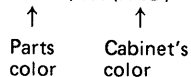

- Items marked "*" are not stocked since they are seldom required for routine service. Some delay should be anticipated when ordering these items.
- The mechanical parts with no reference number in the exploded views are not supplied.
- Hardware (# mark) list is given in the last of this parts list.

The components identified by mark ▲ or dotted line with mark ▲ are critical for safety. Replace only with part number specified.

- Abbreviation
G: Germany model
EA: Saudi Arabia model

5-1. CHASSIS SECTION

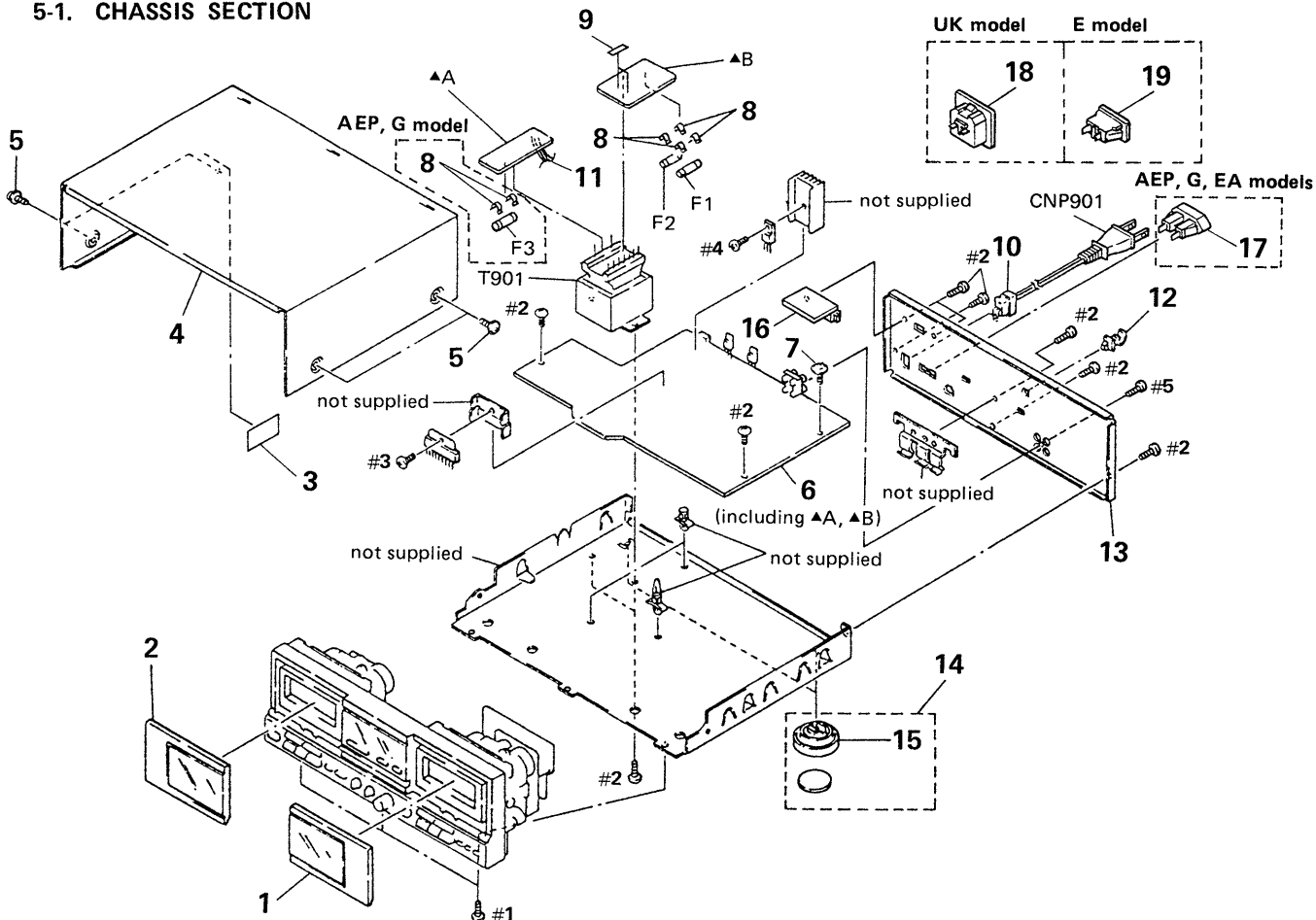

Ref. No.	Part No.	Description	Remark
1	X-3362-149-1	LID (B) ASSY, CASSETTE	
2	X-3362-148-1	LID (A) ASSY, CASSETTE	
3	* 4-615-364-01	SHEET, INSULATING (E, EA)	
4	4-919-379-01	CASE	
5	3-704-366-01	SCREW (CASE) (M3X8)	
6	* A-2006-538-A	MAIN BOARD, COMPLETE (AEP, G)	
6	* A-2006-540-A	MAIN BOARD, COMPLETE (UK)	
6	* A-2006-541-A	MAIN BOARD, COMPLETE (E, EA)	
7	2-383-566-00	SCREW +PTTWH 3X8 (S TIGHT)	
8	1-533-213-31	HOLDER, FUSE	
9	3-701-947-12	LABEL (T1.25A), FUSE	
10	* 3-703-244-00	BUSHING (2104), CORD (AEP, UK, G, EA)	
10	* 3-703-571-11	BUSHING (S) (4516), CORD (E)	
11	* 1-690-057-21	LEAD (WITH CONNECTOR) (2 CORE)	
12	* 2-379-614-01	HOOK	
13	* 3-363-067-21	PANEL, BACK (AEP)	
13	* 3-363-067-31	PANEL, BACK (UK)	

Ref. No.	Part No.	Description	Remark
13	* 3-363-067-41	PANEL, BACK (E)	
13	* 3-363-067-51	PANEL, BACK (EA)	
13	* 3-363-067-61	PANEL, BACK (G)	
14	X-4941-163-1	FOOT ASSY	
15	4-934-884-11	FOOT	
16	1-572-009-11	SELECTOR, VOLTAGE (E, EA)	
17	▲ 1-526-794-11	OUTLET, AC (AEP, G, EA)	
18	▲ 1-526-751-00	OUTLET, AC (UK)	
19	▲ 1-526-882-00	OUTLET, AC (E)	
	CNP901▲	1-575-651-11 CORD, POWER (AEP, G)	
	CNP901▲	1-575-654-11 CORD, POWER (EA)	
	CNP901▲	1-575-656-11 CORD, POWER (E)	
	CNP901▲	1-575-669-21 CORD, POWER (UK)	
	F1▲	1-532-285-00 FUSE, TIME-LAG	
	F2▲	1-532-285-00 FUSE, TIME-LAG	
	F3▲	1-532-078-00 FUSE, TIME-LAG (AEP, G)	
	T901▲	1-449-461-11 TRANSFORMER, POWER (E, EA)	
	T901▲	1-450-605-11 TRANSFORMER, POWER (AEP, UK, G)	

5-2. FRONT PANEL SECTION

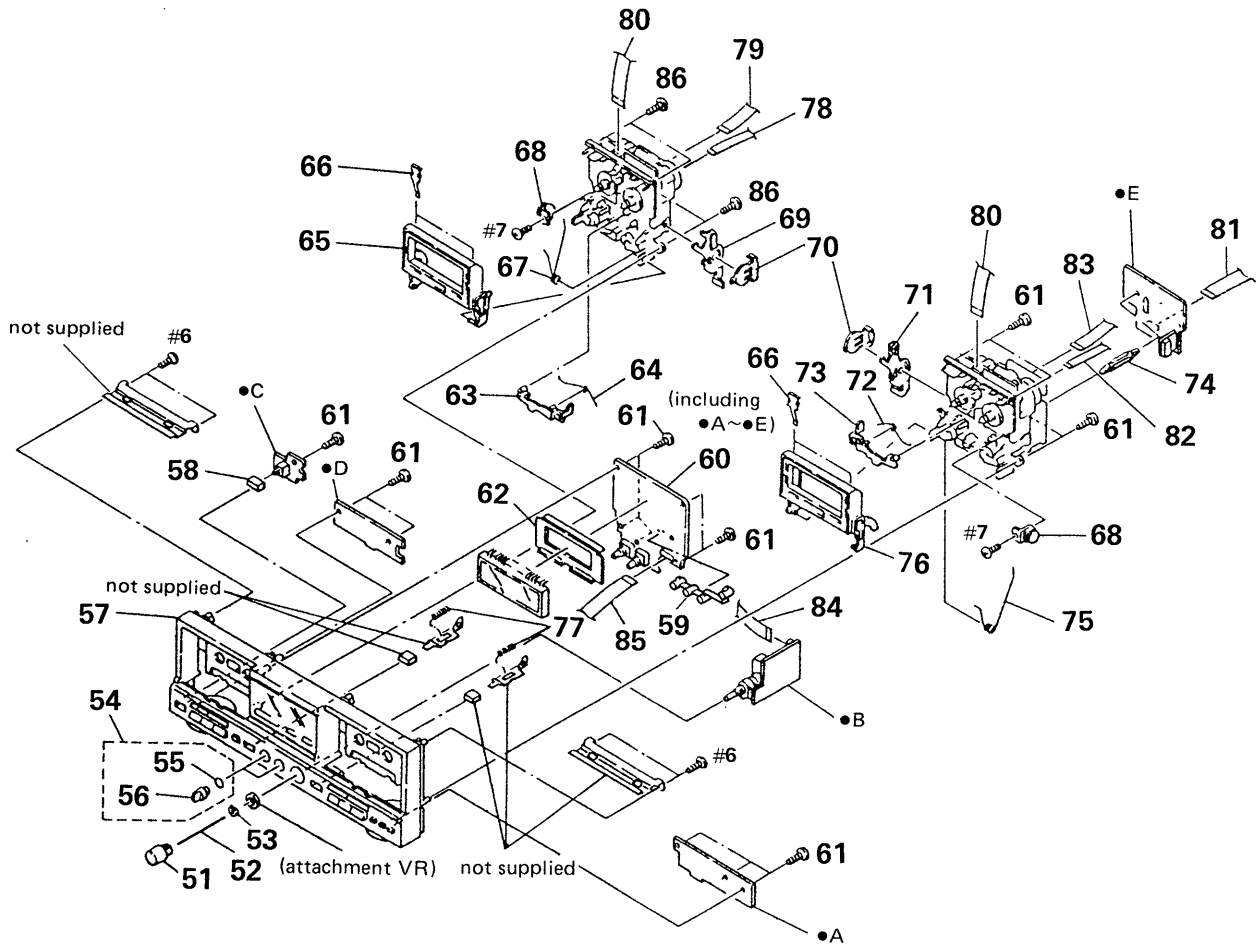

Ref. No.	Part No.	Description	Remark	Ref. No.	Part No.	Description	Remark
51	3-363-064-01	KNOB (REC)		67	3-354-960-01	SPRING (LOADING R), TORSION	
52	4-922-979-11	INDICATOR		68	3-354-963-01	DAMPER	
53	4-922-978-01	HOLDER (FIBER)		69	* 3-354-954-01	LEVER (LOCK LEVER R)	
54	A-2003-693-A	KNOB (DIA. 10) ASSY		70	3-354-957-01	JOINT (LOCK LEVER)	
55	3-354-981-01	SPRING (SUS), RING		71	* 3-354-953-01	LEVER (LOCK LEVER L)	
56	3-354-931-01	KNOB (DIA. 10)		72	3-354-961-01	SPRING (EJ SAFTY SPRING L)	
57	X-3363-182-1	PANEL ASSY, FRONT		73	3-354-955-01	LEVER (EJ SAFTY LEVER L)	
58	4-922-903-01	BUTTON (PW)		74	* 3-682-419-21	HOLDER, P. C. B	
59	* 3-366-281-01	HOLDER, LED		75	3-354-959-01	SPRING (LOADING L), TORSION	
60	* A-2006-539-A	PANEL BOARD, COMPLETE (AEP, UK, G)		76	X-3340-194-1	HOLDER (L) ASSY, CASSETTE	
60	* A-2006-542-A	PANEL BOARD, COMPLETE (E, EA)		77	3-500-131-00	SPRING, COMPRESSION	
61	4-928-635-01	SCREW, +BV (2.6X8) TAPPING		78	1-575-777-11	WIRE, FLAT TYPE (5 CORE)	
62	* 3-350-145-01	HOLDER, FL TUBE		79	1-575-780-11	WIRE, FLAT TYPE (7 CORE)	
63	3-354-956-01	LEVER (EJ SAFTY LEVER R)		80	1-575-781-11	WIRE, FLAT TYPE (9 CORE)	
64	3-354-962-01	SPRING (EJ SAFTY SPRING R)		81	* 1-575-849-11	WIRE, FLAT TYPE (9 CORE)	
65	X-3340-195-1	HOLDER (R) ASSY, CASSETTE		82	1-590-207-21	WIRE, FLAT TYPE (5 CORE)	
66	3-308-823-11	SPRING		83	1-590-208-11	WIRE, FLAT TYPE (7 CORE)	
				84	1-590-209-21	WIRE, FLAT TYPE (7 CORE)	
				85	1-690-034-11	WIRE, FLAT TYPE (13 CORE)	
				86	4-928-635-21	SCREW, +BV (2.6X10) TAPPING	

5-3. MECHANISM DECK SECTION (1)

(DECK A: TCM-190RA11)
(DECK B: TCM-190RB13)

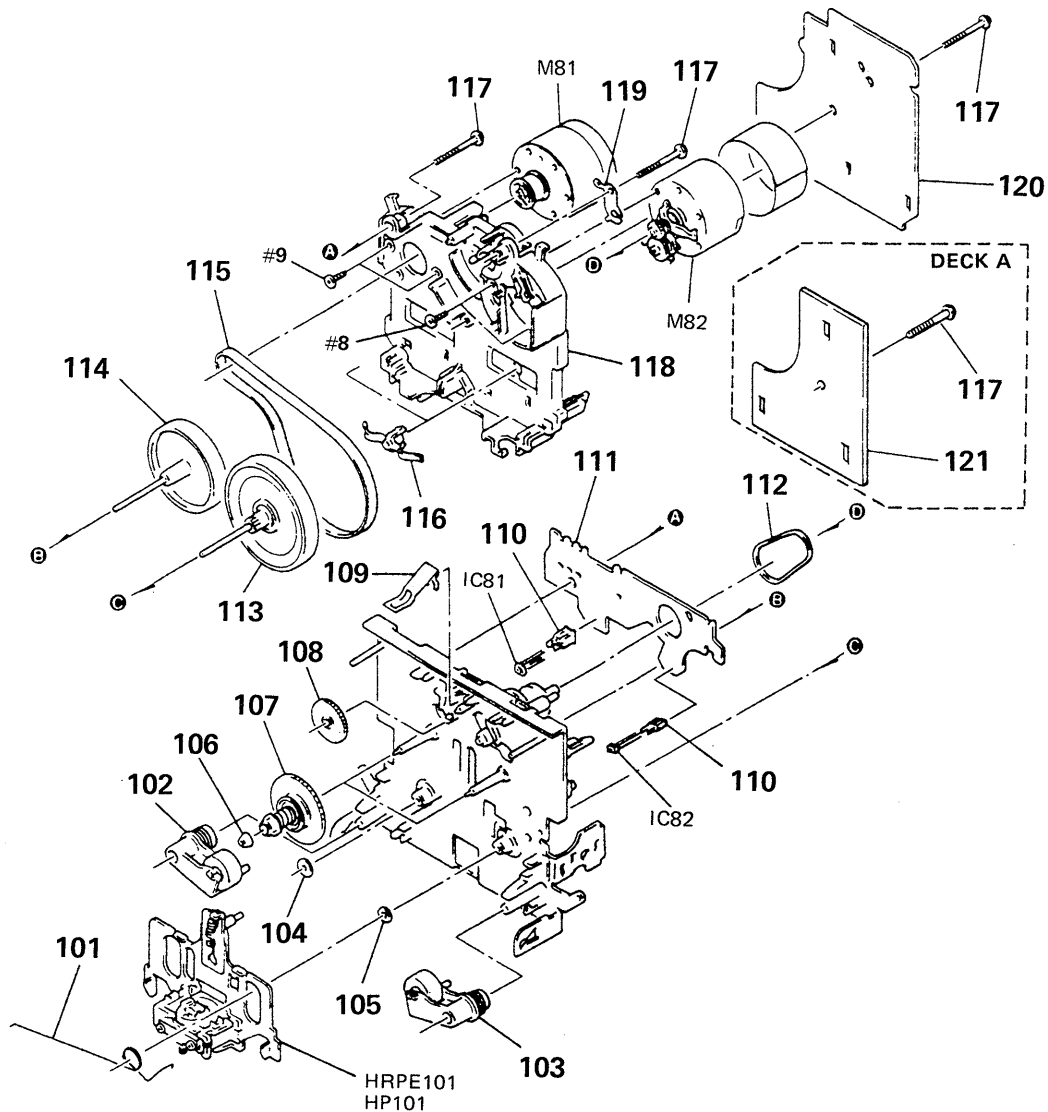

Ref.No.	Part No.	Description	Remark	Ref.No.	Part No.	Description	Remark
101	3-359-455-01	SPRING, TORSION		114	X-3359-410-1	FLYWHEEL (REV) ASSY	
102	X-3359-409-1	LEVER (PINCH LEVER REV) ASSY		115	3-359-417-01	BELT (FLAT), CAPSTAN	
103	X-3359-408-1	LEVER (PINCH LEVER FWD) ASSY		116	3-575-321-00	RETAINER, THRUST, CAPSTAN	
104	3-356-714-01	WASHER		117	3-359-414-01	SCREW (+PTPW 2X23)	
105	3-356-713-01	WASHER		118	* 3-359-436-01	BASE (THRUST RETAINER), FITTING	
106	3-362-308-01	CAP (REEL)		119	3-359-450-01	PLATE, GROUND	
107	X-3362-078-1	TABLE ASSY (B), REEL		120	* A-2006-305-A	AUDIO (RB13) BOARD, COMPLETE (MD-D)	
108	3-359-424-01	GEAR (REV GEAR)		121	1-634-840-11	MD-A BOARD	
109	3-359-430-01	SPRING (CASSETTE RETAINER), LEAF		HP101	A-2003-418-A	BASE ASSY, HEAD	
110	3-343-419-01	HOLDER (S SENSER A)		HRPE101	A-2003-477-A	BASE ASSY, HEAD	
111	1-634-841-11	SW-A BOARD		M81	X-3359-417-1	MOTOR ASSY, CAPSTAN	
112	3-359-466-01	BELT (FR), SQUARE		M82	A-2003-474-A	MOTOR ASSY, REEL	
113	X-3359-406-1	FLYWHEEL (FWD) COMPLETE ASSY					

5-4. MECHANISM DECK SECTION (2)

(DECK A: TCM-190RA11)
(DECK B: TCM-190RB13)

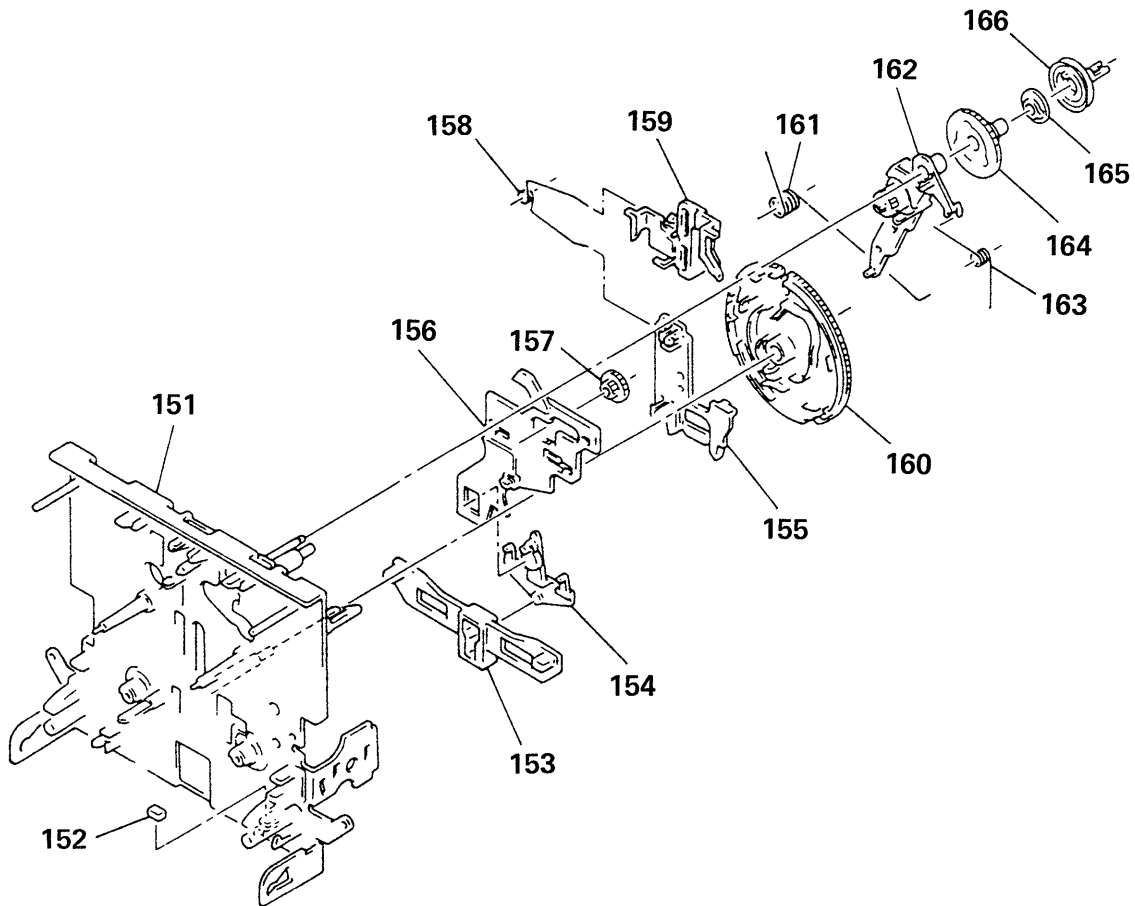

Ref. No.	Part No.	Description	Remark	Ref. No.	Part No.	Description	Remark
151	X-3359-415-1	CASSIS ASSY, MECHANICAL		159	3-359-429-01	SLIDER (BRAKE PLATE)	
152	3-359-469-01	SPACER		160	3-359-420-01	GEAR (CAM GEAR)	
153	* 3-359-425-01	SLIDER (REVERSE SLIDER)		161	3-359-456-01	SPRING (TRIGGER SPRING), TORSION	
154	3-359-426-01	LEVER (REVERSE LEVER)		162	X-3359-405-1	LEVER (FR ARM) ASSY	
155	* 3-359-427-01	SLIDER (LEVERSE SLIDER)		163	3-359-453-01	SPRING (FR ARM), TORSION	
156	* 3-359-415-01	SLIDER (TRIGGER SLIDER)		164	3-359-419-01	GEAR (FR GEAR)	
157	3-359-448-01	GEAR (TRIGGER)		165	3-359-421-01	CLUTCH (REEL DISK)	
158	3-359-454-01	SPRING, TORSION		166	3-359-418-01	PULLEY (FR PULLEY)	

SECTION 6 ELECTRICAL PARTS LIST

NOTE:

- Due to standardization, replacements in the parts list may be different from the parts specified in the diagrams or the components used on the set.
- -XX, -X mean standardized parts, so they may have some difference from the original one.
- RESISTORS
All resistors are in ohms
METAL: Metal-film resistor
METAL OXIDE: Metal Oxide-film resistor
F: nonflammable

- Items marked " * " are not stocked since they are seldom required for routine service. Some delay should be anticipated when ordering these items.
- SEMICONDUCTORS
In each case, u: μ , for example:
uA...: μ A..., uPA...: μ PA...,
uPB...: μ PB..., uPC...: μ PC...,
uPD...: μ PD...
- CAPACITORS
uF: μ F
- COILS
uH: μ H

The components identified by mark or dotted line with mark are critical for safety. Replace only with part number specified.

- Abbreviation
G: Germany model
EA: Saudi Arabia model

Ref. No.	Part No.	Description	Remark	Ref. No.	Part No.	Description	Remark
	* A-2006-305-A	AUDIO (RB13) BOARD, COMPLETE (MD-D) *****				< IC >	
		< CAPACITOR >				< TRANSISTOR >	
C11	1-110-342-11	MYLAR	390PF 5% 50V	1031	8-759-111-44	IC uPC4570C-1	
C12	1-136-157-00	FILM	0.022uF 5% 50V			< RESISTOR >	
C13	1-124-282-00	ELECT	22uF 20% 25V	Q51	8-729-194-57	TRANSISTOR 2SC945-QP	
C21	1-110-342-11	MYLAR	390PF 5% 50V	Q52	8-729-194-57	TRANSISTOR 2SC945-QP	
C22	1-136-157-00	FILM	0.022uF 5% 50V	Q53	8-729-111-29	TRANSISTOR 2SD1616A-K	
				Q71	8-729-820-16	TRANSISTOR 2SA1317-S	
C23	1-124-282-00	ELECT	22uF 20% 25V			< RESISTOR >	
C31	1-124-443-00	ELECT	100uF 20% 10V	R11	1-247-881-00	CARBON 120K 5% 1/4W	
C32	1-124-443-00	ELECT	100uF 20% 10V	R12	1-249-405-11	CARBON 100 5% 1/4W	
C33	1-124-119-00	ELECT	330uF 20% 16V	R13	1-247-882-11	CARBON 130K 5% 1/4W	
C51	1-136-230-00	FILM	0.0022uF 5% 100V	R14	1-249-426-11	CARBON 5.6K 5% 1/4W	
C52	1-136-230-00	FILM	0.0022uF 5% 100V	R21	1-247-881-00	CARBON 120K 5% 1/4W	
C53	1-130-856-00	FILM	0.0068uF 5% 100V	R22	1-249-405-11	CARBON 100 5% 1/4W	
C54	1-136-601-11	FILM	0.01uF 5% 630V	R23	1-247-882-11	CARBON 130K 5% 1/4W	
C55	1-161-494-00	CERAMIC	0.022uF 25V	R24	1-249-426-11	CARBON 5.6K 5% 1/4W	
C56	1-126-157-11	ELECT	10uF 20% 16V	R31	1-249-409-11	CARBON 220 5% 1/4W	
C57	1-162-294-31	CERAMIC	0.001uF 10% 50V	R32	1-249-409-11	CARBON 220 5% 1/4W	
C71	1-124-907-11	ELECT	10uF 20% 50V	R51	1-249-441-11	CARBON 100K 5% 1/4W	
C72	1-124-907-11	ELECT	10uF 20% 50V	R52	1-249-441-11	CARBON 100K 5% 1/4W	
		< CONNECTOR >		R54	1-212-849-00	FUSIBLE 4.7 5% 1/4W F	
CNP31	* 1-568-824-11	SOCKET, CONNECTOR 5P		R71	1-247-864-11	CARBON 24K 5% 1/4W	
CNP32	* 1-564-709-11	PIN, CONNECTOR (SMALL TYPE) 7P		R72	1-249-433-11	CARBON 22K 5% 1/4W	
CNP34	* 1-565-344-11	PIN, CONNECTOR (PC BOARD) 8P				< VARIABLE RESISTOR >	
CNP71	* 1-564-705-11	PIN, CONNECTOR (SMALL TYPE) 3P		R73	1-249-437-11	CARBON 47K 5% 1/4W	
CNP72	* 1-564-706-11	PIN, CONNECTOR (SMALL TYPE) 4P		R74	1-249-437-11	CARBON 47K 5% 1/4W	
CNP73	* 1-568-826-11	SOCKET, CONNECTOR 7P				< DIODE >	
D31	8-719-107-94	DIODE 1SS202-1		RV11	1-238-597-11	RES, ADJ, CARBON 1K	
				RV21	1-238-597-11	RES, ADJ, CARBON 1K	
				RV71	1-238-600-11	RES, ADJ, CARBON 10K	
				RV72	1-238-600-11	RES, ADJ, CARBON 10K	

MD-D

MAIN

TRANS.S

TRANS.AE

Ref.No.	Part No.	Description	Remark	Ref.No.	Part No.	Description	Remark
		< RELAY >					
RY31	1-515-726-11	RELAY		C502	1-124-910-11	ELECT 47uF 20% 50V	
		< TRANSFORMER >		C541	1-126-163-11	ELECT 4.7uF 20% 50V	
T51	1-433-376-11	TRANSFORMER, BIAS OSCILLATION		C542	1-124-910-11	ELECT 47uF 20% 50V	

		* A-2006-538-A MAIN BOARD, COMPLETE (AEP,G)		C543	1-124-910-11	ELECT 47uF 20% 50V	
		* A-2006-540-A MAIN BOARD, COMPLETE (UK)		C551	1-124-910-11	ELECT 47uF 20% 50V	
		* A-2006-541-A MAIN BOARD, COMPLETE (E, EA)		C552	1-124-910-11	ELECT 47uF 20% 50V	
		*****		C561	1-124-910-11	ELECT 47uF 20% 50V	
		* 1-533-213-31 HOLDER, FUSE		C562	1-124-910-11	ELECT 47uF 20% 50V	
		* 1-568-824-11 SOCKET, CONNECTOR 5P		C571	1-126-161-11	ELECT 2.2uF 20% 50V	
		* 1-568-826-11 SOCKET, CONNECTOR 7P		C572	1-162-217-31	CERAMIC 56PF 5% 50V	
		* 1-568-828-11 SOCKET, CONNECTOR 9P		C573	1-136-157-00	FILM 0.022uF 5% 50V	
		7-682-548-09 SCREW +B 3X8		C574	1-126-163-11	ELECT 4.7uF 20% 50V	
		7-682-547-04 SCREW +BVTT 3X6 (S)		C575	1-126-161-11	ELECT 2.2uF 20% 50V	
		< CAPACITOR >		C576	1-126-161-11	ELECT 2.2uF 20% 50V	
				C578	1-162-217-31	CERAMIC 56PF 5% 50V	
C101	1-126-161-11	ELECT 2.2uF 20% 50V		C661	1-124-910-11	ELECT 47uF 20% 50V	
C102	1-162-294-31	CERAMIC 0.001uF 10% 50V		C662	1-124-910-11	ELECT 47uF 20% 50V	
C103	1-106-351-00	MYLAR 2200PF 5% 200V		C663	1-126-161-11	ELECT 2.2uF 20% 50V	
C104	1-106-351-00	MYLAR 2200PF 5% 200V		C702	1-126-029-11	ELECT 3300uF 20% 25V	
C105	1-136-174-00	FILM 0.56uF 5% 50V		C703	1-126-029-11	ELECT 3300uF 20% 25V	
C106	1-136-171-00	FILM 0.33uF 5% 50V		C704	1-124-910-11	ELECT 47uF 20% 50V	
C107	1-126-163-11	ELECT 4.7uF 20% 50V		C705	1-124-360-00	ELECT 1000uF 20% 16V	
C108	1-126-163-11	ELECT 4.7uF 20% 50V		C706	1-124-360-00	ELECT 1000uF 20% 16V	
C131	1-136-157-00	FILM 0.022uF 5% 50V		C707	1-126-161-11	ELECT 2.2uF 20% 50V	
C141	1-126-300-11	ELECT 0.47uF 20% 50V		C708	1-124-472-11	ELECT 470uF 20% 10V	
C142	1-126-059-11	ELECT 10uF 20% 50V		C709	1-124-919-11	ELECT 220uF 20% 63V	
C143	1-126-059-11	ELECT 10uF 20% 50V		C710	1-126-161-11	ELECT 2.2uF 20% 50V	
C151	1-126-163-11	ELECT 4.7uF 20% 50V		C711	1-126-059-11	ELECT 10uF 20% 50V	
C161	1-126-161-11	ELECT 2.2uF 20% 50V		C712	1-126-059-11	ELECT 10uF 20% 50V	
C201	1-126-161-11	ELECT 2.2uF 20% 50V		C716	1-136-157-00	FILM 0.022uF 5% 50V	
C202	1-162-294-31	CERAMIC 0.001uF 10% 50V		C801	1-126-163-11	ELECT 4.7uF 20% 50V	
C203	1-106-351-00	MYLAR 2200PF 5% 200V		C802	1-126-101-11	ELECT 100uF 20% 16V	
C204	1-106-351-00	MYLAR 2200PF 5% 200V		C803	1-124-910-11	ELECT 47uF 20% 50V	
C205	1-136-174-00	FILM 0.56uF 5% 50V		C804	1-124-910-11	ELECT 47uF 20% 50V	
C206	1-136-171-00	FILM 0.33uF 5% 50V		C805	1-164-159-11	CERAMIC 0.1uF 50V	
C207	1-126-163-11	ELECT 4.7uF 20% 50V		C806	1-162-294-31	CERAMIC 0.001uF 10% 50V	
C208	1-126-163-11	ELECT 4.7uF 20% 50V		C807	1-162-306-11	CERAMIC 0.01uF 20% 16V	
C231	1-136-157-00	FILM 0.022uF 5% 50V		C808	1-126-163-11	ELECT 4.7uF 20% 50V	
C241	1-126-300-11	ELECT 0.47uF 20% 50V		C809	1-161-494-00	CERAMIC 0.022uF 25V	
C242	1-126-059-11	ELECT 10uF 20% 50V		C810	1-164-159-11	CERAMIC 0.1uF 50V	
C243	1-126-059-11	ELECT 10uF 20% 50V		C811	1-161-494-00	CERAMIC 0.022uF 25V	
C251	1-126-163-11	ELECT 4.7uF 20% 50V		C816	1-164-159-11	CERAMIC 0.1uF 50V	
C261	1-126-161-11	ELECT 2.2uF 20% 50V		C861	1-164-159-11	CERAMIC 0.1uF 50V	
C501	1-124-910-11	ELECT 47uF 20% 50V		C862	1-164-159-11	CERAMIC 0.1uF 50V	
				C863	1-124-443-00	ELECT 100uF 20% 10V	
				C864	1-164-159-11	CERAMIC 0.1uF 50V	
				C869	1-126-101-11	ELECT 100uF 20% 16V	
				C870	1-126-101-11	ELECT 100uF 20% 16V	
				C871	1-126-300-11	ELECT 0.47uF 20% 50V	

MAIN

TRANS.S

TRANS.AE

Ref. No.	Part No.	Description	Remark
C872	1-124-910-11	ELECT 47uF 20% 50V	
C873	1-124-910-11	ELECT 47uF 20% 50V	
C874	1-162-294-31	CERAMIC 0.001uF 10% 50V	
< CONNECTOR >			
CN391	* 1-568-828-11	SOCKET, CONNECTOR 9P	
CN501	* 1-564-708-11	PIN, CONNECTOR (SMALL TYPE) 6P	
CN701	1-564-044-00	BASE POST, MCD CONNECTOR 7P	
CN703	* 1-564-321-00	PIN, CONNECTOR 2P (AEP, UK, G)	
CN704	* 1-580-629-11	PIN, CONNECTOR 2P (AEP, UK, G)	
CN801	* 1-568-826-11	SOCKET, CONNECTOR 7P	
CN802	* 1-564-338-61	PIN, CONNECTOR 4P	
CN803	* 1-568-832-11	SOCKET, CONNECTOR 13P	
CN804	* 1-564-338-71	PIN, CONNECTOR 4P	
CN805	* 1-564-339-00	PIN, CONNECTOR 5P	
CN810	* 1-565-561-11	PIN, CONNECTOR 3P	
< DIODE >			
D161	8-719-912-20	DIODE 1SS120	
D261	8-719-912-20	DIODE 1SS120	
D501	8-719-933-54	DIODE HZS9A2L	
D571	8-719-912-20	DIODE 1SS120	
D661	8-719-912-20	DIODE 1SS120	
D662	8-719-912-20	DIODE 1SS120	
D701	8-719-200-77	DIODE 10E2N	
D702	8-719-200-77	DIODE 10E2N	
D703	8-719-200-77	DIODE 10E2N	
D704	8-719-200-77	DIODE 10E2N	
D706	8-719-933-33	DIODE HZS6A1L	
D707	8-719-933-33	DIODE HZS6A1L	
D709	8-719-933-38	DIODE HZS6B3L	
D712	8-719-200-77	DIODE 10E2N	
D713	8-719-200-77	DIODE 10E2N	
D714	8-719-200-77	DIODE 10E2N	
D715	8-719-200-77	DIODE 10E2N	
D716	8-719-912-20	DIODE 1SS120	
D717	8-719-912-20	DIODE 1SS120	
D718	8-719-933-33	DIODE HZS6A1L	
D801	8-719-200-77	DIODE 10E2N	
D802	8-719-912-20	DIODE 1SS120	
D803	8-719-912-20	DIODE 1SS120	
D804	8-719-912-20	DIODE 1SS120	
D805	8-719-000-81	DIODE UZL-7L3	
D861	8-719-200-77	DIODE 10E2N	
D862	8-719-200-77	DIODE 10E2N	
D863	8-719-912-20	DIODE 1SS120	
D864	8-719-912-20	DIODE 1SS120	

Ref. No.	Part No.	Description	Remark
< IC >			
IC501	8-752-036-34	IC CXA1330S	
IC502	8-759-000-49	IC MC140668CP	
IC531	8-759-140-53	IC uPD4053BC	
IC541	8-752-039-24	IC CXA1398P	
IC551	8-759-634-51	IC M5218AP	
IC561	8-759-945-58	IC RC4558P	
IC571	8-759-945-58	IC RC4558P	
IC661	8-759-000-48	IC MC14052BCP	
IC701	8-759-945-58	IC RC4558P	
IC801	8-759-635-43	IC M50944-164SP	
IC802	8-759-962-08	IC BA6208	
IC861	8-759-207-05	IC TA7272P	
IC862	8-759-635-94	IC M50925SP-482SP	
IC863	8-759-240-50	IC TC4050BP	
< JACK >			
J501	1-565-258-11	JACK, PIN 4P (LINE IN/LINE OUT)	
< FILTER >			
LPF101	1-236-087-11	FILTER, LOW PASS	
LPF201	1-236-087-11	FILTER, LOW PASS	
< TRANSISTOR >			
Q101	8-729-620-05	TRANSISTOR 2SC2603-EF	
Q131	8-729-900-80	TRANSISTOR DTC114ES	
Q201	8-729-620-05	TRANSISTOR 2SC2603-EF	
Q231	8-729-900-80	TRANSISTOR DTC114ES	
Q501	8-729-900-65	TRANSISTOR DTA144ES	
Q502	8-729-900-89	TRANSISTOR DTC144ES	
Q503	8-729-900-65	TRANSISTOR DTA144ES	
Q551	8-729-900-65	TRANSISTOR DTA144ES	
Q552	8-729-900-65	TRANSISTOR DTA144ES	
Q571	8-729-900-74	TRANSISTOR DTC143TS	
Q572	8-729-119-76	TRANSISTOR 2SA1175-HFE	
Q602	8-729-900-89	TRANSISTOR DTC144ES	
Q603	8-729-900-65	TRANSISTOR DTA144ES	
Q605	8-729-900-65	TRANSISTOR DTA144ES	
Q661	8-729-900-89	TRANSISTOR DTC144ES	
Q662	8-729-900-80	TRANSISTOR DTC114ES	
Q663	8-729-900-74	TRANSISTOR DTC143TS	
Q665	8-729-141-30	TRANSISTOR 2SC3623A-LK	
Q666	8-729-119-76	TRANSISTOR 2SA1175-HFE	
Q667	8-729-900-80	TRANSISTOR DTC114ES	
Q668	8-729-900-74	TRANSISTOR DTC143TS	
Q669	8-729-900-80	TRANSISTOR DTC114ES	
Q670	8-729-900-61	TRANSISTOR DTA114ES	
Q671	8-729-900-61	TRANSISTOR DTA114ES	

MAIN

TRANS.S

TRANS.AE

Ref. No.	Part No.	Description	Remark	Ref. No.	Part No.	Description	Remark
Q672	8-729-119-76	TRANSISTOR 2SA1175-HFE		R202	1-249-417-11	CARBON 1K 5%	1/4W
Q701	8-729-924-90	TRANSISTOR 2SB1370-EF		R204	1-249-417-11	CARBON 1K 5%	1/4W
Q702	8-729-111-55	TRANSISTOR 2SD1312-K		R205	1-249-423-11	CARBON 3.3K 5%	1/4W
Q703	8-729-924-90	TRANSISTOR 2SB1370-EF		R206	1-249-428-11	CARBON 8.2K 5%	1/4W
Q704	8-729-620-05	TRANSISTOR 2SC2603-EF		R207	1-247-864-11	CARBON 24K 5%	1/4W
Q707	8-729-118-01	TRANSISTOR 2SB1116-K		R208	1-249-414-11	CARBON 560 5%	1/4W
Q708	8-729-118-01	TRANSISTOR 2SB1116-K		R212	1-249-421-11	CARBON 2.2K 5%	1/4W
Q709	8-729-900-74	TRANSISTOR DTC143TS		R213	1-249-429-11	CARBON 10K 5%	1/4W
Q710	8-729-900-74	TRANSISTOR DTC143TS		R214	1-249-421-11	CARBON 2.2K 5%	1/4W
Q801	8-729-900-61	TRANSISTOR DTA114ES		R231	1-249-421-11	CARBON 2.2K 5%	1/4W
Q802	8-729-900-61	TRANSISTOR DTA114ES		R233	1-249-423-11	CARBON 3.3K 5%	1/4W
Q803	8-729-900-89	TRANSISTOR DTC144ES		R234	1-247-887-00	CARBON 220K 5%	1/4W
Q804	8-729-900-61	TRANSISTOR DTA114ES		R241	1-249-429-11	CARBON 10K 5%	1/4W
Q806	8-729-900-61	TRANSISTOR DTA114ES		R242	1-249-425-11	CARBON 4.7K 5%	1/4W
Q808	8-729-900-61	TRANSISTOR DTA114ES		R251	1-249-417-11	CARBON 1K 5%	1/4W
Q809	8-729-900-80	TRANSISTOR DTC114ES		R252	1-249-427-11	CARBON 6.8K 5%	1/4W
Q810	8-729-620-05	TRANSISTOR 2SC2603-EF		R253	1-247-887-00	CARBON 220K 5%	1/4W
Q811	8-729-900-89	TRANSISTOR DTC144ES		R254	1-249-441-11	CARBON 100K 5%	1/4W
Q861	8-729-900-61	TRANSISTOR DTA114ES		R261	1-249-417-11	CARBON 1K 5%	1/4W
Q862	8-729-900-80	TRANSISTOR DTC114ES		R262	1-249-437-11	CARBON 47K 5%	1/4W
Q863	8-729-801-84	TRANSISTOR 2SB1013-4		R263	1-249-431-11	CARBON 15K 5%	1/4W
Q864	8-729-801-84	TRANSISTOR 2SB1013-4		R264	1-249-410-11	CARBON 270 5%	1/4W
		< RESISTOR >		R265	1-249-441-11	CARBON 100K 5%	1/4W
R101	1-249-431-11	CARBON 15K 5%	1/4W	R501	1-249-417-11	CARBON 1K 5%	1/4W
R102	1-249-417-11	CARBON 1K 5%	1/4W	R502	1-215-455-00	METAL 27K 1%	1/6W
R104	1-249-417-11	CARBON 1K 5%	1/4W	R503	1-249-433-11	CARBON 22K 5%	1/4W
R105	1-249-423-11	CARBON 3.3K 5%	1/4W	R504	1-249-433-11	CARBON 22K 5%	1/4W
R106	1-249-428-11	CARBON 8.2K 5%	1/4W	R505	1-249-433-11	CARBON 22K 5%	1/4W
R107	1-247-864-11	CARBON 24K 5%	1/4W	R531	1-249-433-11	CARBON 22K 5%	1/4W
R108	1-249-414-11	CARBON 560 5%	1/4W	R532	1-249-433-11	CARBON 22K 5%	1/4W
R112	1-249-421-11	CARBON 2.2K 5%	1/4W	R541	1-249-415-11	CARBON 680 5%	1/4W
R113	1-249-429-11	CARBON 10K 5%	1/4W	R542	1-249-421-11	CARBON 2.2K 5%	1/4W
R114	1-249-421-11	CARBON 2.2K 5%	1/4W	R543	1-247-864-11	CARBON 24K 5%	1/4W
R131	1-249-421-11	CARBON 2.2K 5%	1/4W	R544	1-249-433-11	CARBON 22K 5%	1/4W
R133	1-249-423-11	CARBON 3.3K 5%	1/4W	R545	1-249-433-11	CARBON 22K 5%	1/4W
R134	1-247-887-00	CARBON 220K 5%	1/4W	R546	1-249-433-11	CARBON 22K 5%	1/4W
R141	1-249-429-11	CARBON 10K 5%	1/4W	R551	1-249-433-11	CARBON 22K 5%	1/4W
R142	1-249-425-11	CARBON 4.7K 5%	1/4W	R552	1-249-433-11	CARBON 22K 5%	1/4W
R151	1-249-417-11	CARBON 1K 5%	1/4W	R571	1-247-887-00	CARBON 220K 5%	1/4W
R152	1-249-427-11	CARBON 6.8K 5%	1/4W	R572	1-249-425-11	CARBON 4.7K 5%	1/4W
R153	1-247-887-00	CARBON 220K 5%	1/4W	R573	1-249-441-11	CARBON 100K 5%	1/4W
R154	1-249-441-11	CARBON 100K 5%	1/4W	R574	1-249-428-11	CARBON 8.2K 5%	1/4W
R161	1-249-417-11	CARBON 1K 5%	1/4W	R575	1-249-423-11	CARBON 3.3K 5%	1/4W
R162	1-249-437-11	CARBON 47K 5%	1/4W	R576	1-249-441-11	CARBON 100K 5%	1/4W
R163	1-249-431-11	CARBON 15K 5%	1/4W	R577	1-249-421-11	CARBON 2.2K 5%	1/4W
R164	1-249-410-11	CARBON 270 5%	1/4W	R578	1-249-441-11	CARBON 100K 5%	1/4W
R165	1-249-441-11	CARBON 100K 5%	1/4W	R579	1-249-429-11	CARBON 10K 5%	1/4W
R201	1-249-431-11	CARBON 15K 5%	1/4W	R580	1-249-441-11	CARBON 100K 5%	1/4W
				R581	1-249-435-11	CARBON 33K 5%	1/4W

MAIN

TRANS.S

TRANS.AE

Ref. No.	Part No.	Description	Remark	Ref. No.	Part No.	Description	Remark
R582	1-249-417-11	CARBON	1K 5% 1/4W	R815	1-249-421-11	CARBON	2. 2K 5% 1/4W
R583	1-249-431-11	CARBON	15K 5% 1/4W	R816	1-249-421-11	CARBON	2. 2K 5% 1/4W
R601	1-247-862-11	CARBON	20K 5% 1/4W	R817	1-249-405-11	CARBON	100 5% 1/4W
R602	1-249-429-11	CARBON	10K 5% 1/4W	R818	1-249-405-11	CARBON	100 5% 1/4W
R604	1-249-441-11	CARBON	100K 5% 1/4W	R819	1-249-405-11	CARBON	100 5% 1/4W
R605	1-247-864-11	CARBON	24K 5% 1/4W	R820	1-249-393-11	CARBON	10 5% 1/4W
R606	1-247-862-11	CARBON	20K 5% 1/4W	R821	1-247-903-00	CARBON	1M 5% 1/4W
R607	1-249-429-11	CARBON	10K 5% 1/4W	R822	1-249-433-11	CARBON	22K 5% 1/4W
R661	1-249-425-11	CARBON	4. 7K 5% 1/4W	R823	1-249-437-11	CARBON	47K 5% 1/4W
R663	1-249-407-11	CARBON	150 5% 1/4W	R824	1-249-437-11	CARBON	47K 5% 1/4W
R665	1-247-840-00	CARBON	2. 4K 5% 1/4W	R825	1-249-437-11	CARBON	47K 5% 1/4W
R666	1-247-850-11	CARBON	6. 2K 5% 1/4W	R826	1-249-433-11	CARBON	22K 5% 1/4W
R667	1-249-441-11	CARBON	100K 5% 1/4W	R827	1-249-424-11	CARBON	3. 9K 5% 1/4W
R669	1-247-883-00	CARBON	150K 5% 1/4W	R828	1-249-433-11	CARBON	22K 5% 1/4W
R670	1-249-433-11	CARBON	22K 5% 1/4W	R829	1-249-425-11	CARBON	4. 7K 5% 1/4W
R671	1-249-405-11	CARBON	100 5% 1/4W	R830	1-249-433-11	CARBON	22K 5% 1/4W
R672	1-249-425-11	CARBON	4. 7K 5% 1/4W	R861	1-249-405-11	CARBON	100 5% 1/4W
R673	1-249-414-11	CARBON	560 5% 1/4W	R862	1-247-872-11	CARBON	51K 5% 1/4W
R674	1-249-433-11	CARBON	22K 5% 1/4W	R863	1-247-872-11	CARBON	51K 5% 1/4W
R675	1-249-407-11	CARBON	150 5% 1/4W	R864	1-249-437-11	CARBON	47K 5% 1/4W
R676	1-249-433-11	CARBON	22K 5% 1/4W	R865	1-247-866-11	CARBON	30K 5% 1/4W
R677	1-249-425-11	CARBON	4. 7K 5% 1/4W	R866	1-249-425-11	CARBON	4. 7K 5% 1/4W
R701	1-249-420-11	CARBON	1. 8K 5% 1/4W	R867	1-247-862-11	CARBON	20K 5% 1/4W
R702	1-249-427-11	CARBON	6. 8K 5% 1/4W	R868	1-249-434-11	CARBON	27K 5% 1/4W
R703	1-249-419-11	CARBON	1. 5K 5% 1/4W	R869	1-247-862-11	CARBON	20K 5% 1/4W
R704	1-249-429-11	CARBON	10K 5% 1/4W	R870	1-249-425-11	CARBON	4. 7K 5% 1/4W
R705	1-249-419-11	CARBON	1. 5K 5% 1/4W	R871	1-249-434-11	CARBON	27K 5% 1/4W
R706	1-249-427-11	CARBON	6. 8K 5% 1/4W	R872	1-249-437-11	CARBON	47K 5% 1/4W
R707	1-249-427-11	CARBON	6. 8K 5% 1/4W	R873	1-247-866-11	CARBON	30K 5% 1/4W
R708	1-249-409-11	CARBON	220 5% 1/4W	R874	1-247-872-11	CARBON	51K 5% 1/4W
R709	1-249-417-11	CARBON	1K 5% 1/4W	R875	1-247-872-11	CARBON	51K 5% 1/4W
R710	1-249-420-11	CARBON	1. 8K 5% 1/4W	R876	1-249-405-11	CARBON	100 5% 1/4W
R711	1-249-429-11	CARBON	10K 5% 1/4W	R877	1-249-429-11	CARBON	10K 5% 1/4W
R712	1-249-429-11	CARBON	10K 5% 1/4W	R878	1-249-415-11	CARBON	680 5% 1/4W
R713	1-249-421-11	CARBON	2. 2K 5% 1/4W	R879	1-249-429-11	CARBON	10K 5% 1/4W
R714	1-249-419-11	CARBON	1. 5K 5% 1/4W	R880	1-249-415-11	CARBON	680 5% 1/4W
R719	1-249-436-11	CARBON	39K 5% 1/4W	R881	1-249-429-11	CARBON	10K 5% 1/4W
R720	1-249-433-11	CARBON	22K 5% 1/4W	R882	1-247-903-00	CARBON	1M 5% 1/4W
R801	1-249-421-11	CARBON	2. 2K 5% 1/4W	R883	1-249-433-11	CARBON	22K 5% 1/4W
R802	1-249-432-11	CARBON	18K 5% 1/4W	R884	1-249-433-11	CARBON	22K 5% 1/4W
R803	1-249-429-11	CARBON	10K 5% 1/4W	R885	1-249-429-11	CARBON	10K 5% 1/4W
R807	1-249-429-11	CARBON	10K 5% 1/4W	R886	1-249-429-11	CARBON	10K 5% 1/4W
R808	1-249-429-11	CARBON	10K 5% 1/4W	R887	1-249-434-11	CARBON	27K 5% 1/4W
R809	1-249-433-11	CARBON	22K 5% 1/4W	R888	1-247-895-00	CARBON	470K 5% 1/4W
R810	1-249-433-11	CARBON	22K 5% 1/4W	R889	1-249-434-11	CARBON	27K 5% 1/4W
R811	1-249-433-11	CARBON	22K 5% 1/4W	R890	1-247-895-00	CARBON	470K 5% 1/4W
R812	1-249-425-11	CARBON	4. 7K 5% 1/4W	R891	1-247-895-00	CARBON	470K 5% 1/4W
R813	1-249-421-11	CARBON	2. 2K 5% 1/4W	R892	1-249-434-11	CARBON	27K 5% 1/4W
R814	1-249-421-11	CARBON	2. 2K 5% 1/4W				

MAIN

MD-A

CONTROL SW(A)

CONTROL SW(B)

HX PRO

REC VOL

DISPLAY

POWER

V.S

TRANS.E

Ref. No.	Part No.	Description	Remark
R893	1-247-895-00	CARBON 470K 5%	1/4W
R894	1-249-434-11	CARBON 27K 5%	1/4W
< VARIABLE RESISTOR >			
RV141	1-238-016-11	RES. ADJ. CARBON 10K	
RV241	1-238-016-11	RES. ADJ. CARBON 10K	
< TEST PIN >			
TP801	* 1-564-336-00	PIN, CONNECTOR 2P	
TP802	* 1-564-506-11	PLUG, CONNECTOR 3P	
< CERAMIC >			
X801	1-577-358-21	VIBRATOR, CERAMIC	
X861	1-577-358-21	VIBRATOR, CERAMIC	

	* 1-634-840-11	MD-A BOARD (RA11)	

< CAPACITOR >			
C11	1-110-342-11	MYLAR 390PF 5%	50V
C12	1-136-157-00	FILM 0.022uF 5%	50V
C13	1-124-282-00	ELECT 22uF 20%	25V
C18	1-162-219-31	CERAMIC 68PF 5%	50V
C21	1-110-342-11	MYLAR 390PF 5%	50V
C22	1-136-157-00	FILM 0.022uF 5%	50V
C23	1-124-282-00	ELECT 22uF 20%	25V
C28	1-162-219-31	CERAMIC 68PF 5%	50V
C31	1-124-443-00	ELECT 100uF 20%	10V
C32	1-124-443-00	ELECT 100uF 20%	10V
C71	1-124-907-11	ELECT 10uF 20%	50V
C72	1-124-907-11	ELECT 10uF 20%	50V
< CONNECTOR >			
CNP31	* 1-568-824-11	SOCKET, CONNECTOR 5P	
CNP32	* 1-564-706-11	PIN, CONNECTOR (SMALL TYPE) 4P	
CNP71	* 1-564-705-11	PIN, CONNECTOR (SMALL TYPE) 3P	
CNP72	* 1-564-706-11	PIN, CONNECTOR (SMALL TYPE) 4P	
CNP73	* 1-568-826-11	SOCKET, CONNECTOR 7P	
< IC >			
IC31	8-759-111-44	IC uPC4570C-1	
< TRANSISTOR >			
Q71	8-729-820-16	TRANSISTOR 2SA1317-S	

Ref. No.	Part No.	Description	Remark
< RESISTOR >			
R11	1-247-881-00	CARBON 120K 5%	1/4W
R12	1-249-405-11	CARBON 100 5%	1/4W
R13	1-247-882-11	CARBON 130K 5%	1/4W
R14	1-249-426-11	CARBON 5.6K 5%	1/4W
R21	1-247-881-00	CARBON 120K 5%	1/4W
R22	1-249-405-11	CARBON 100 5%	1/4W
R23	1-247-882-11	CARBON 130K 5%	1/4W
R24	1-249-426-11	CARBON 5.6K 5%	1/4W
R31	1-249-409-11	CARBON 220 5%	1/4W
R32	1-249-409-11	CARBON 220 5%	1/4W
R71	1-247-864-11	CARBON 24K 5%	1/4W
R72	1-249-433-11	CARBON 22K 5%	1/4W
R73	1-249-437-11	CARBON 47K 5%	1/4W
R74	1-249-437-11	CARBON 47K 5%	1/4W
< VARIABLE RESISTOR >			
RV11	1-238-597-11	RES. ADJ. CARBON 1K	
RV21	1-238-597-11	RES. ADJ. CARBON 1K	
RV71	1-238-600-11	RES. ADJ. CARBON 10K	
RV72	1-238-600-11	RES. ADJ. CARBON 10K	

	* A-2006-539-A	PANEL BOARD, COMPLETE (AEP, UK, G)	
	* A-2006-542-A	PANEL BOARD, COMPLETE (E, EA)	

	* 3-350-145-01	HOLDER, FL TUBE	
< CAPACITOR >			
C391	1-136-153-00	FILM 0.01uF 5%	50V
C392	1-136-157-00	FILM 0.022uF 5%	50V
C393	1-136-165-00	FILM 0.1uF 5%	50V
C394	1-136-437-11	FILM 220PF 5%	630V
C395	1-136-433-11	FILM 100PF 5%	630V
C396	1-130-472-00	MYLAR 0.0012uF 5%	50V
C397	1-136-273-91	FILM 75PF 5%	630V
C398	1-162-288-31	CERAMIC 330PF 10%	50V
C491	1-136-153-00	FILM 0.01uF 5%	50V
C492	1-136-157-00	FILM 0.022uF 5%	50V
C493	1-136-165-00	FILM 0.1uF 5%	50V
C494	1-136-437-11	FILM 220PF 5%	630V
C495	1-136-433-11	FILM 100PF 5%	630V
C496	1-130-472-00	MYLAR 0.0012uF 5%	50V
C497	1-136-273-91	FILM 75PF 5%	630V
C498	1-162-288-31	CERAMIC 330PF 10%	50V
C691	1-126-023-11	ELECT 100uF 20%	16V
C692	1-126-022-11	ELECT 47uF 20%	10V
C693	1-126-300-11	ELECT 0.47uF 20%	50V

CONTROL SW(A)

CONTROL SW(B)

HX PRO

REC VOL

DISPLAY

POWER

V.S

TRANS.E

Ref. No.	Part No.	Description	Remark	Ref. No.	Part No.	Description	Remark
C694	1-107-045-00	MICA	3.9PF	500V	R492	1-249-435-11	CARBON 33K 5% 1/4W
C835	1-164-159-11	CERAMIC	0.1uF	50V	R493	1-249-393-11	CARBON 10 5% 1/4W
C836	1-164-159-11	CERAMIC	0.1uF	50V	R494	1-247-883-00	CARBON 150K 5% 1/4W
C837	1-164-159-11	CERAMIC	0.1uF	50V	R495	1-249-430-11	CARBON 12K 5% 1/4W
C838	1-164-159-11	CERAMIC	0.1uF	50V	R835	1-249-408-11	CARBON 180 5% 1/4W
C839	1-126-163-11	ELECT	4.7uF	20% 50V	R841	1-249-407-11	CARBON 150 5% 1/4W
C951	1-124-910-11	ELECT	47uF	20% 50V	R842	1-249-409-11	CARBON 220 5% 1/4W
C952	1-164-159-11	CERAMIC	0.1uF	50V	R843	1-249-411-11	CARBON 330 5% 1/4W
C953	1-124-910-11	ELECT	47uF	20% 50V	R844	1-249-418-11	CARBON 1.2K 5% 1/4W
C954	1-161-494-00	CERAMIC	0.022uF	25V	R845	1-249-417-11	CARBON 1K 5% 1/4W
C955	1-161-327-00	CERAMIC	0.0033uF	20% 16V	R846	1-249-420-11	CARBON 1.8K 5% 1/4W
C956	1-161-327-00	CERAMIC	0.0033uF	20% 16V	R851	1-249-407-11	CARBON 150 5% 1/4W
< CONNECTOR >				R852	1-249-409-11	CARBON 220 5% 1/4W	
CN502	* 1-564-708-11	PIN, CONNECTOR (SMALL TYPE) 6P			R853	1-249-411-11	CARBON 330 5% 1/4W
CN705	* 1-564-321-00	PIN, CONNECTOR 2P (E, EA)			R854	1-249-413-11	CARBON 470 5% 1/4W
CN706	* 1-580-629-11	PIN, CONNECTOR 2P (E, EA)			R855	1-249-415-11	CARBON 680 5% 1/4W
CN707	* 1-690-059-11	LEAD (WITH CONNECTOR) (5 CORE) (E, EA)			R856	1-249-417-11	CARBON 1K 5% 1/4W
CNP391	* 1-568-828-11	SOCKET, CONNECTOR 9P			R901	1-249-407-11	CARBON 150 5% 1/4W
CNP392	* 1-565-347-11	SOCKET, CONNECTOR (PC BOARD) 8P			R902	1-249-409-11	CARBON 220 5% 1/4W
CNP801	* 1-568-826-11	SOCKET, CONNECTOR 7P			R903	1-249-411-11	CARBON 330 5% 1/4W
CNP803	* 1-568-832-11	SOCKET, CONNECTOR 13P			R904	1-249-418-11	CARBON 1.2K 5% 1/4W
< DIODE >				R905	1-249-417-11	CARBON 1K 5% 1/4W	
D951	8-719-301-39	DIODE SEL2210S-D (SAF)			R911	1-249-407-11	CARBON 150 5% 1/4W
D952	8-719-301-39	DIODE SEL2210S-D (CROSS)			R912	1-249-409-11	CARBON 220 5% 1/4W
D953	8-719-301-39	DIODE SEL2210S-D (FADE)			R913	1-249-411-11	CARBON 330 5% 1/4W
D954	8-719-301-39	DIODE SEL2210S-D (EDIT)			R914	1-249-413-11	CARBON 470 5% 1/4W
< FLUORESCENT >				R915	1-249-415-11	CARBON 680 5% 1/4W	
FL951	1-519-625-11	INDICATOR TUBE, FLUORESCENT			R916	1-249-417-11	CARBON 1K 5% 1/4W
< IC >				R917	1-249-420-11	CARBON 1.8K 5% 1/4W	
IC691	8-759-106-56	IC uPC1297CA			R918	1-249-424-11	CARBON 3.9K 5% 1/4W
IC951	8-759-321-92	IC HD614022S			R951	1-249-408-11	CARBON 180 5% 1/4W
< COIL >				R952	1-249-408-11	CARBON 180 5% 1/4W	
L391	1-410-780-11	INDUCTOR	27mH		R953	1-249-408-11	CARBON 180 5% 1/4W
L491	1-410-780-11	INDUCTOR	27mH		R954	1-249-408-11	CARBON 180 5% 1/4W
< RESISTOR >				R955	1-247-903-00	CARBON 1M 5% 1/4W	
R391	1-249-429-11	CARBON	10K	5% 1/4W	R956	1-249-435-11	CARBON 33K 5% 1/4W
R392	1-249-435-11	CARBON	33K	5% 1/4W	R957	1-249-437-11	CARBON 47K 5% 1/4W
R393	1-249-393-11	CARBON	10	5% 1/4W	R958	1-249-437-11	CARBON 47K 5% 1/4W
R394	1-247-883-00	CARBON	150K	5% 1/4W	R959	1-249-437-11	CARBON 47K 5% 1/4W
R395	1-249-430-11	CARBON	12K	5% 1/4W	R960	1-249-433-11	CARBON 22K 5% 1/4W
R491	1-249-429-11	CARBON	10K	5% 1/4W	< VARIABLE RESISTOR >		
					RV391	1-230-722-11	RES. ADJ. CARBON 22K
					RV491	1-230-722-11	RES. ADJ. CARBON 22K
					RV501	1-241-232-11	RES. VAR. CARBON 20K/20K/20K (REC LEVEL)

CONTROL SW(A)

CONTROL SW(B)

HX PRO

REC VOL

DISPLAY

POWER

V.S

TRANS.E

SW-A

Ref. No.	Part No.	Description	Remark
		< SWITCH >	
S841	1-554-303-21	SWITCH, TACTILE (■)	
S842	1-554-303-21	SWITCH, TACTILE (▷)	
S843	1-554-303-21	SWITCH, TACTILE (◁)	
S844	1-554-303-21	SWITCH, TACTILE (PAUSE)	
S845	1-554-303-21	SWITCH, TACTILE (◄◄)	
S846	1-554-303-21	SWITCH, TACTILE (►►)	
S847	1-554-303-21	SWITCH, TACTILE (REC)	
S851	1-554-303-21	SWITCH, TACTILE (■)	
S852	1-554-303-21	SWITCH, TACTILE (▷)	
S853	1-554-303-21	SWITCH, TACTILE (◁)	
S854	1-554-303-21	SWITCH, TACTILE (PAUSE)	
S855	1-554-303-21	SWITCH, TACTILE (REC MUTE)	
S856	1-554-303-21	SWITCH, TACTILE (◄◄)	
S857	1-554-303-21	SWITCH, TACTILE (►►)	
S901	1-554-303-21	SWITCH, TACTILE (CROSS)	
S902	1-554-303-21	SWITCH, TACTILE (FADE)	
S903	1-554-303-21	SWITCH, TACTILE (EDIT)	
S904	1-554-303-21	SWITCH, TACTILE (TIME SET)	
S906	1-572-513-11	SWITCH, ROTARY (DOLBY NR)	
S911	1-554-303-21	SWITCH, TACTILE (HIGH SPEED)	
S912	1-554-303-21	SWITCH, TACTILE (NORMAL SPEED)	
S913	1-554-303-21	SWITCH, TACTILE (SAF)	
S914	1-554-303-21	SWITCH, TACTILE (FADER)	
S915	1-554-303-21	SWITCH, TACTILE (RESET)	
S916	1-554-303-21	SWITCH, TACTILE (MEMORY)	
S917	1-554-303-21	SWITCH, TACTILE (A/B)	
S918	1-572-513-11	SWITCH, ROTARY (DIRECTION MODE)	
S951	1-554-118-00	SWITCH, PUSH (1 KEY) (POWER)	
		< TRANSFORMER >	
T391	1-433-367-11	TRANSFORMER, BIAS OSSCILATION	
T491	1-433-367-11	TRANSFORMER, BIAS OSSCILATION	
		< TEST PIN >	
TP691	* 1-564-518-11	PLUG, CONNECTOR 3P	
		< CERAMIC >	
X951	1-577-359-21	VIBRATOR, CERAMIC	

	* 1-634-841-11	SW-A BOARD (RA11) (DECK A)	

	3-343-419-01	HOLDER (S SENSER A)	

Ref. No.	Part No.	Description	Remark
		< CONNECTOR >	
CNP81	* 1-568-852-11	SOCKET, CONNECTOR 9P	
		< IC >	
IC81	8-719-710-03	IC PHOTO REFLECTOR NJL5165K-B	
IC82	8-719-710-03	IC PHOTO REFLECTOR NJL5165K-B	
		< RESISTOR >	
R84	1-249-417-11	CARBON 1K 5% 1/4W	
R85	1-249-408-11	CARBON 180 5% 1/4W	
R86	1-249-408-11	CARBON 180 5% 1/4W	
		< SWITCH >	
S81	1-571-958-11	SWITCH, PUSH (1 KEY) (STOP)	
S82	1-571-281-21	SWITCH, LEAF (CrO2)	
S86	1-571-281-21	SWITCH, LEAF (HALF)	

	* 1-634-841-11	SW-A BOARD (RB31) (DECK B)	

	3-343-419-01	HOLDER (S SENSER A)	
		< CONNECTOR >	
CNP81	* 1-568-852-11	SOCKET, CONNECTOR 9P	
		< IC >	
IC81	8-719-710-03	IC PHOTO REFLECTOR NJL5165K-B	
IC82	8-719-710-03	IC PHOTO REFLECTOR NJL5165K-B	
		< RESISTOR >	
R81	1-249-414-11	CARBON 560 5% 1/4W	
R82	1-247-818-11	CARBON 300 5% 1/4W	
R83	1-247-834-11	CARBON 1.3K 5% 1/4W	
R84	1-249-417-11	CARBON 1K 5% 1/4W	
R85	1-249-408-11	CARBON 180 5% 1/4W	
R86	1-249-408-11	CARBON 180 5% 1/4W	
		< SWITCH >	
S81	1-571-958-11	SWITCH, PUSH (1 KEY) (STOP)	
S82	1-571-281-21	SWITCH, LEAF (CrO2)	
S83	1-571-281-21	SWITCH, LEAF (METAL)	
S84	1-571-281-21	SWITCH, LEAF (ERASE PROOF)	
S85	1-571-281-21	SWITCH, LEAF (ERASE PROOF)	
S86	1-571-281-21	SWITCH, LEAF (HALF DET)	

Ref.No.	Part No.	Description	Remark
MISCELLANEOUS *****			
8	1-533-213-01	HOLDER, FUSE	
11	* 1-690-057-21	LEAD (WITH CONNECTOR) (2 CORE)	
16	1-572-009-11	SELECTOR, VOLTAGE (E, EA)	
17	△ 1-526-794-11	OUTLET, AC (AEP, G, EA)	
18	△ 1-526-751-00	OUTLET, AC (UK)	
19	△ 1-526-882-00	OUTLET, AC (E)	
78	1-575-777-11	WIRE, FLAT TYPE (5 CORE)	
79	1-575-780-11	WIRE, FLAT TYPE (7 CORE)	
80	1-575-781-11	WIRE, FLAT TYPE (9 CORE)	
81	* 1-575-849-11	WIRE, FLAT TYPE (9 CORE)	
82	1-590-207-21	WIRE, FLAT TYPE (5 CORE)	
83	1-590-208-11	WIRE, FLAT TYPE (7 CORE)	
84	1-590-209-21	WIRE, FLAT TYPE (7 CORE)	
85	1-690-034-11	WIRE, FLAT TYPE (13 CORE)	

CNP901△ 1-575-651-11 CORD, POWER (AEP, G)
 CNP901△ 1-575-654-11 CORD, POWER (EA)
 CNP901△ 1-575-656-11 CORD, POWER (E)
 CNP901△ 1-575-669-21 CORD, POWER (UK)

F1 △ 1-532-285-00 FUSE, TIME-LAG
 F2 △ 1-532-285-00 FUSE, TIME-LAG
 F3 △ 1-532-078-00 FUSE, TIME-LAG (AEP, G)
 HP101 A-2003-418-A BASE ASSY, HEAD
 HRPE101 A-2003-477-A BASE ASSY, HEAD
 M81 X-3359-417-1 MOTOR ASSY, CAPSTAN
 M82 A-2003-474-A MOTOR ASSY, REEL
 T901 △ 1-449-461-11 TRANSFORMER, POWER (E, EA)
 T901 △ 1-450-605-11 TRANSFORMER, POWER (AEP, UK, G)

ACCESSORY & PACKING MATERIAL

1-465-774-11 REMOTE COMMANDER (RM-S905) (UK, E, EA)
 1-558-271-11 CORD, CONNECTION (AEP, G)
 1-559-533-11 CORD, CONNECTION (AEP, G)
 * 3-343-648-01 CUSHION (AEP, G)
 * 3-350-154-01 CUSHION (UK, E, EA)
 * 3-369-336-01 INDIVIDUAL CARTON (AEP, G)
 3-701-630-00 BAG, POLYETHYLENE (G)
 3-753-426-11 MANUAL, INSTRUCTION (ENGLISH, F, S, P) (AEP)
 3-753-426-41 MANUAL, INSTRUCTION (D, NL, S, I) (AEP, G)

F: FRENCH NL: DUTCH
 E: SPANISH S: SWEDISH
 P: PORTUGUESE I: ITALIAN
 D: GERMAN

Note: The components identified by mark △ or dotted line with mark △ are critical for safety. Replace only with part number specified.

Ref.No.	Part No.	Description	Remark
HARDWARE LIST *****			
# 1	7-682-547-09	SCREW +BVTT 3X6 (S)	
# 2	7-685-646-79	SCREW +BVTP 3X8 TYPE2 N-S	
# 3	7-682-547-04	SCREW +BVTT 3X6 (S)	
# 4	7-682-548-09	SCREW +B 3X8	
# 5	7-621-849-00	SCREW (BV/RING)	
# 6	7-685-134-19	SCREW +BTP 2.6X8 TYPE2 N-S	
# 7	7-621-773-95	SCREW +BVTT 2.6X6 (S)	
# 8	7-627-556-08	SCREW +P 2.6X2.8	
# 9	7-621-775-00	SCREW +B 2.6X3	

TC-D905

SONY® SERVICE MANUAL

*AEP Model
UK Model
E Model*

SUPPLEMENT-1

File this supplement with the service manual.

Block Diagram

• BLOCK DIAGRAM

