

# TC-EX7/EX10

## SERVICE MANUAL

AEP Model  
UK Model  
TC-EX7/EX10

E Model  
Australian Model  
TC-EX10

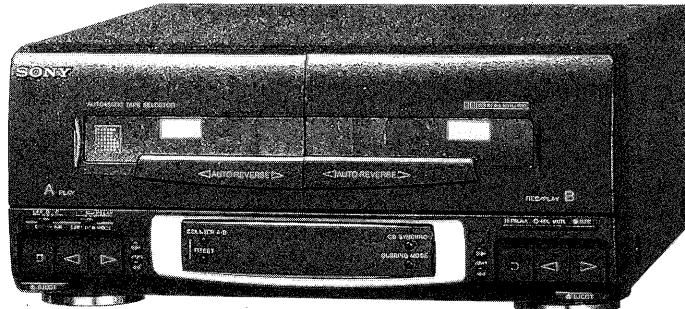



Photo : TC-EX10

TC-EX7 is cassette deck section in MHC-EX7.  
TC-EX10 is cassette deck section in MHC-EX9AV/EX10AV.

\* Dolby noise reduction and HX Pro headroom extension manufactured under license from Dolby Laboratories Licensing Corporation. HX Pro originated by Bang & Olufsen.

"DOLBY", the double-D symbol  and "HX PRO" are trademarks of Dolby Laboratories Licensing Corporation.

Model Name Using Similar Mechanism		TC-A590
Tape Transport Mechanism Type	DECK A	TCM-190RA12CL
	DECK B	TCM-190RB12CL

### SPECIFICATIONS

#### Stereo cassette deck

Recording system

4-track 2-channel stereo

Frequency response

(DOLBY NR OFF)

40 - 13,000 Hz ( $\pm 3$  dB),

using Sony TYPE I cassette

40 - 14,000 Hz ( $\pm 3$  dB),

using Sony TYPE II cassette

40 - 15,000 Hz ( $\pm 3$  dB),

using Sony TYPE IV cassette

Wow and flutter

0.1% WRMS $\pm$ 0.3% (DIN)

Dimensions

Approx. 280 x 125 x 285 mm (w/h/d)

(11 1/8 x 5 x 11 1/4 inches)

Mass Approx. 3.0 kg (6 lb 10 oz)





STEREO CASSETTE DECK  
**SONY**®

## TABLE OF CONTENTS

<i>Section</i>	<i>Title</i>	<i>Page</i>
<b>1. GENERAL</b>	.....	3
<b>2. ADJUSTMENTS</b>		
2-1. Mechanical Adjustments	.....	4
2-2. Electrical Adjustments	.....	4
<b>3. EXPLANATION OF IC TERMINALS</b>	.....	8
<b>4. DIAGRAMS</b>		
4-1. Block Diagram	.....	11
4-2. Printed Wiring Boards	.....	15
4-3. Schematic Diagram	.....	19
<b>5. EXPLODED VIEWS</b>		
5-1. Chassis Section	.....	24
5-2. Front Panel Section	.....	25
5-3. Mechanism Section-1	.....	26
5-4. Mechanism Section-2	.....	27
<b>6. ELECTRICAL PARTS LIST</b>	.....	28

## SAFETY-RELATED COMPONENT WARNING!!

COMPONENTS IDENTIFIED BY MARK  OR DOTTED LINE WITH MARK  ON THE SCHEMATIC DIAGRAMS AND IN THE PARTS LIST ARE CRITICAL TO SAFE OPERATION. REPLACE THESE COMPONENTS WITH SONY PARTS WHOSE PART NUMBERS APPEAR AS SHOWN IN THIS MANUAL OR IN SUPPLEMENTS PUBLISHED BY SONY.

## SERVICING NOTE

### • POWER SUPPLIED WHILE SERVICING

This unit does not work independently because of not having the power supply.

It must be unite together with the other units when repaired.

### • Power supply method using Jig

Connect the set and jig as shown in the diagram below and turn on the power switch.

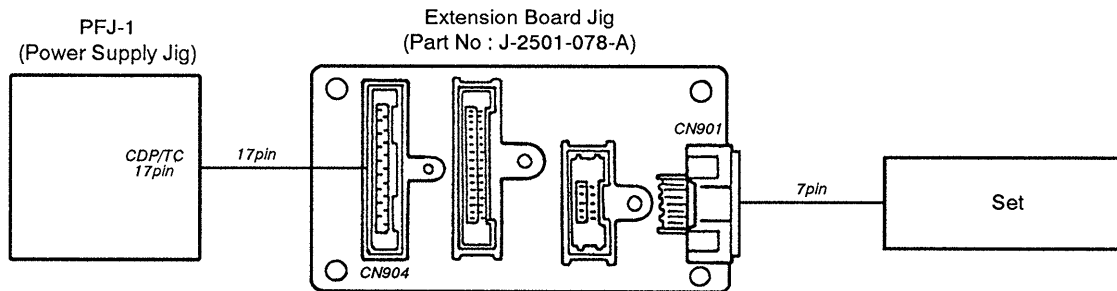

## SECTION 1 GENERAL

This section is extracted from instruction manual.

### Index to Parts and Controls

#### Front Panel

##### Tape player

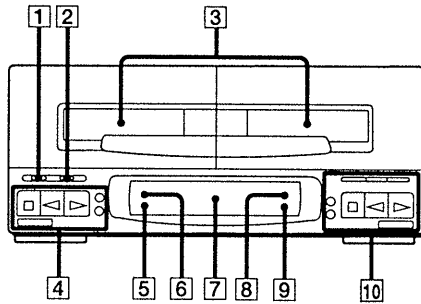

- 1 DOLBY NR selector
  - 2 DIRECTION MODE selector
  - 3 Cassette compartments
  - 4 Tape operating buttons (for deck A)
    - ▷ (front side play)
    - ◁ (reverse side play)
    - (stop)
    - ▶▶ (fast rightward and AMS\*\*)
    - ◀◀ (fast leftward and AMS\*\*)
    - ▲ EJECT button (14)
  - 5 RESET (counter reset) button
  - 6 COUNTER A/B button
  - 7 Display window
  - 8 CD SYNCHRO button
  - 9 DUBBING MODE button
  - 10 Tape operating buttons (for deck B)
    - ▷ (front side play)
    - ◁ (reverse side play)
    - (stop)
    - ▶▶ (fast rightward and AMS\*\*)
    - ◀◀ (fast leftward and AMS\*\*)
    - || PAUSE
    - REC MUTE button
    - REC (recording)
    - ▲ EJECT button
- \*\*AMS: Automatic Music Sensor

#### Display Window

##### Tape Player

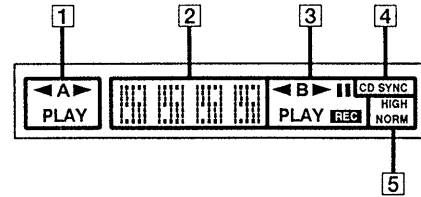

- 1 Deck A status indication
- 2 Tape counter indication
- 3 Deck B status indication
- 4 CD SYNC (synchro) indication
- 5 Dubbing mode indication

## SECTION 2 ADJUSTMENTS

### 2-1. MECHANICAL ADJUSTMENTS

#### PRECAUTION

- Clean the following parts with a denatured alcohol-moistened swab:
 

record/playback/erase head	pinch roller
rubber belts	capstan
idlers	
- Demagnetize the record/playback head with a head demagnetizer. (Head demagnetizer do not approach for the erase head.)
- Do not use a magnetized screwdriver for the adjustment.
- After the adjustments, apply suitable locking compound to the parts adjusted.
- The adjustments should be performed with the rated power supply voltage unless otherwise noted.

#### Torque Measurement

Torque	Torque meter	Meter reading
Forward	CQ-102C	30 to 60g • cm (0.42 to 0.83oz • inch)
Forward back tension	CQ-102C	1 to 5g • cm (0.014 to 0.069 oz • inch)
Reverse	CQ-102RC	30 to 60g • cm (0.42 to 0.83 oz • inch)
Reverse back tension	CQ-102RC	1 to 5g • cm (0.014 to 0.069 oz • inch)
FF/REW	CQ-201B	65 to 90g • cm (0.91 to 1.25 oz • inch)

### 2-2. ELECTRICAL ADJUSTMENTS

#### PRECAUTION

- The adjustment should be performed in the publication. (Be sure to male playback adjustment at first.)
- The adjustments and measurement should be performed for both L-CH and R-CH.
  - Switch position
 

DOLBY NR switch	: OFF
DIRECTION MODE switch	: ⇄
  - Standard record position :  
Deliver the standard input signal level to input jack as follows.

— Record Mode —

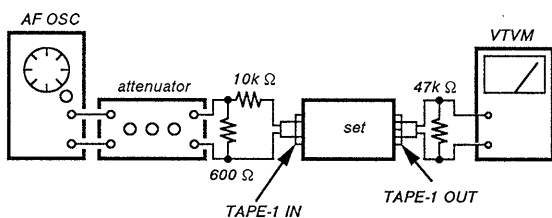

#### Standard Input Level

Input terminal	TAPE-1 (LINE IN)
source impedance	10k Ω
input signal level	0.5V ( - 3.8dB)

#### Standard Output Level

Output terminal	TAPE-1 (LINE OUT)
load impedance	47k Ω
output signal level	0.5V ( - 3.8dB)

#### Test Tape

Tape	Contents	Use
P-4-A100	10kHz, - 10dB	Azimuth Adjustment
P-4-L300	315Hz, 0dB	PB Level Adjustment
WS-48B	3kHz, 0dB	Tape Speed Adjustment

0dB=0.775V

#### Test Mode

- If the power voltage of deck supplied by TA-EX7/EX10.
  - ① Short-circuit following portion (IC104 ⑤ pin to Digital GND (JW612)) on the main board.
  - ② Turn the POWER on.
  - ③ Open the short-circuit to release test mode.

#### [MAIN BOARD]

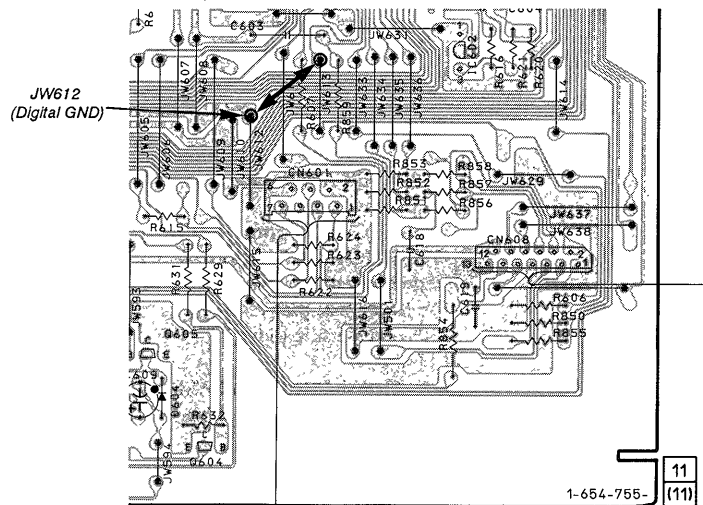

- If the power voltage deck supplied by jig. After, turning on the power, press the STOP button of both DECK-A and DECK-B at the same time.

#### Record/Playback Head Azimuth Adjustment

DECK-A DECK-B

#### Procedure :

- Forward playback Mode

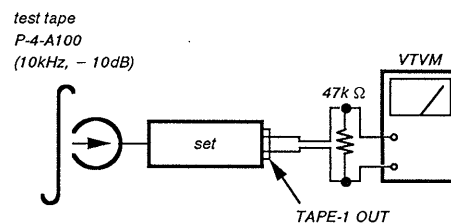

2. Turn the adjustment screw for the maximum output levels. If these levels do not match, turn the adjustment screw until both of output levels match together within 1dB.

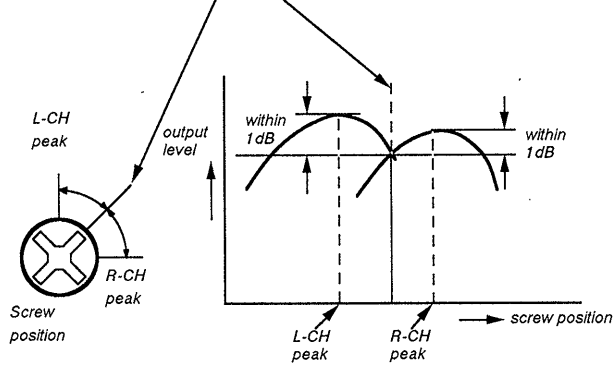

3. Playback Mode

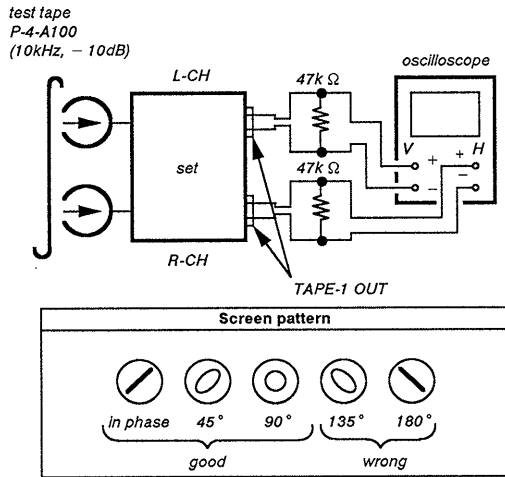

4. Change the reverse playback mode and repeat the steps 1 to 3.  
5. After the adjustment, lock the adjustment screws with suitable locking compound.

**Adjustment Location :** – record/playback head –

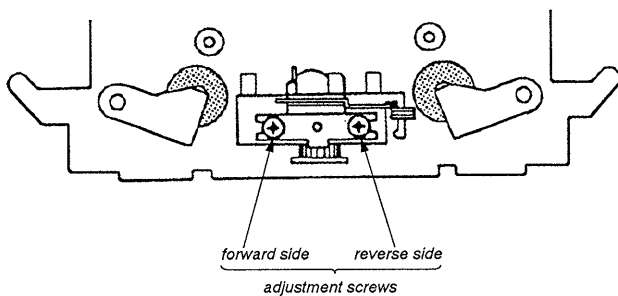

## Tape Speed Adjustment

DECK-A DECK-B

### Procedure :

- Forward Playback Mode –

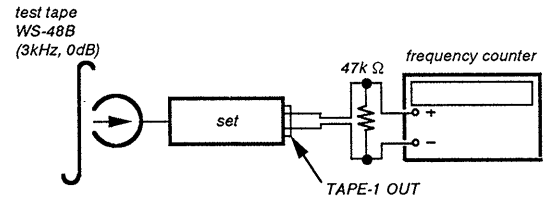

(high speed adjustment)

1. Set to test mode. (Refer to page 4)
2. Set to FWD playback mode.
3. Press the DUBBING MODE button .
4. Adjust RV72 so that the frequency counter reading becomes  $6,000 \pm 60\text{Hz}$ .

(normal speed adjustment)

1. Set to FWD playback mode.
2. Set the DUBBING MODE button to NORMAL.
3. Adjust RV71 so that the frequency counter reading becomes  $3,000 \pm 30\text{Hz}$ .

Frequency difference between the beginning and the end of the tape should be within 3%.

Frequency difference between the deck A and deck B the beginning of the tape should be within 1.5%.

**Adjustment Location :** AUDIO board.

## Playback Level Adjustment

DECK-A DECK-B

### Procedure :

- Forward Playback Mode –

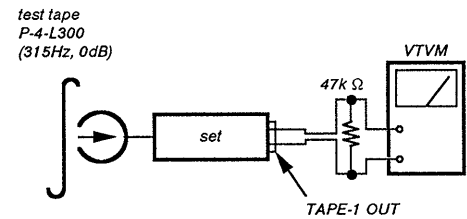

Adjust RV11(L-CH) and RV21(R-CH) so the VTVM reading becomes the adjustment limits below.

### Adjustment Value :

TAPE-1 OUT level : –  $7.4 \pm 1.0\text{dB}$  (0.294 to 0.371V)

Level difference between channels : within 0.5dB

Confirm the TAPE-1 OUT level does not change in playback mode while changing the mode from playback to stop several times.

**Adjustment Location :** AUDIO board.

## Record Bias Adjustment DECK-B

### Procedure :

1. Record Mode

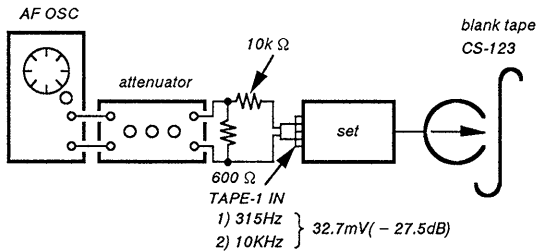

2. Playback Mode

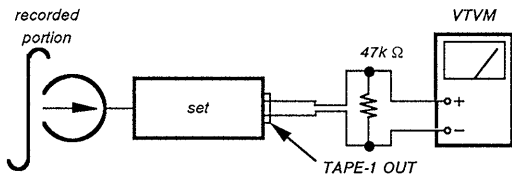

Confirm that the 10kHz playback output is  $0 \pm 0.5\text{dB}$  relative to the 315Hz output. If necessary, adjust RV81 (L-CH), RV91 (R-CH) and repeat the steps given above.

Adjustment Location : AUDIO board.

## Record Level Adjustment DECK-B

### Procedure :

1. Record Mode

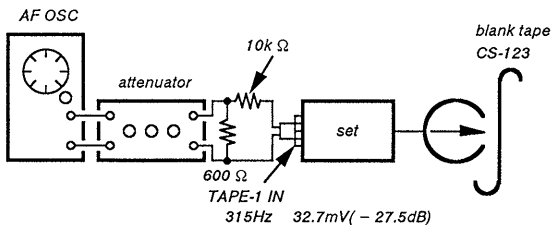

2. Playback Mode

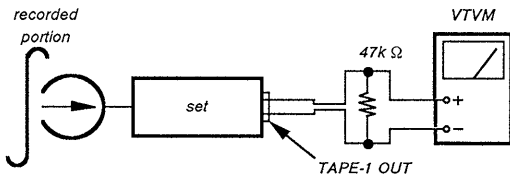

Confirm playback the tape recorded become adjustment level as follows.

If necessary, adjust RV101 (L-CH), RV201 (R-CH) and repeat the steps 1 and 2.

### Adjustment Value :

TAPE-1 OUT level :  $-27.5 \pm 0.5\text{dB}$  (30.8 to 34.6mV)

Adjustment Location : TC MAIN board.

## Bias Consumption Current Adjustment

This adjustment should be performed when replacing the head assy or the bias oscillating transformer (T81, T91).

### Procedure :

( ) : R-CH

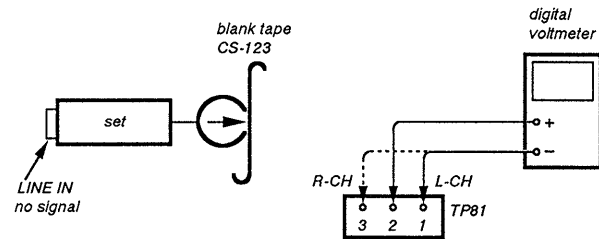

1. Connect the digital voltmeter to test point TP81.
2. Set RV81 (RV91) to mechanical center.
3. Set to FWD record mode.
4. Adjust T81 (T91) so that the digital voltmeter reading becomes minimum.

Adjustment Value : Maximum 140mV

Adjustment Location : AUDIO board

— Adjustment Parts Location Diagrams —

**[MAIN BOARD]**

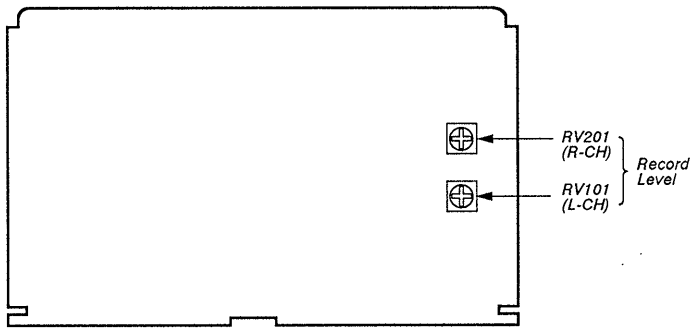

DECK-A :  
**[AUDIO BOARD]**

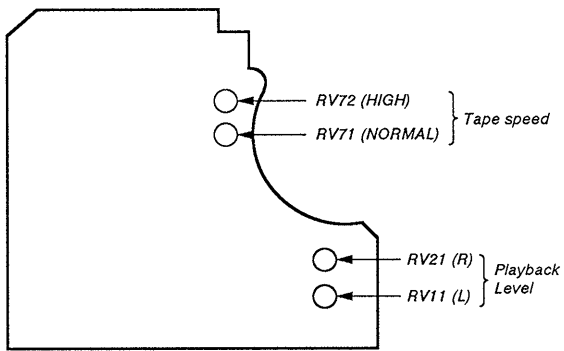

DECK-B :  
**[AUDIO BOARD]**

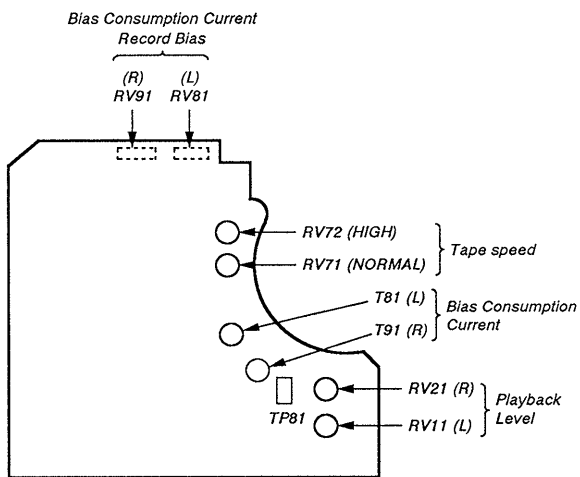

### SECTION 3 EXPLANATION OF IC TERMINALS

#### IC104 M38123M4-118FP SYSTEM CONTROL (MAIN BOARD)

Pin No.	Pin name	I/O	Description
1	B HALF	I	B Half detection input. "L" : Presence "H" : Nothing
2	KEY3	I	Not used. (+5V)
3	KEY2		
4	KEY1		
5	TEST	I	Electrical adjustment test mode setting. "L" : Test mode
6	DISP RST	O	Reset output to IC301 (M38122M2-102FP)
7	DISP SYNC	O	SYNC output to IC301 (M38122M2-102FP)
8	DISP CLK	O	Clock output to IC301 (M38122M2-102FP)
9	DISP OUT	O	Data output to IC301 (M38122M2-102FP)
10	DISP IN	I	Data input from IC301 (M38122M2-102FP)
11	B REEL2	O	Deck B reel motor control output.
12	B REEL3		
13	B REEL1		
14	A REEL1	O	Deck A reel motor control output.
15	A REEL3		
16	A REEL2		
17	PWR IN	I	+5V power supply input.
18	AUB IN	I	Audio bus input.
19	NRST	I	Microcomputer reset input.
20	AUB OUT	O	Audio bus output.
21	XC OUT	O	Not used. (GND)
22	X IN	I	Oscillator connection pins. (4MHz)
23	X OUT	O	
24	Vss	-	GND.
25	VER	-	GND.
26	PWR OUT	O	Not used. (OPEN)
27	LINE MUTE	O	Line mute ON/OFF. "L" : ON
28	BIAS	O	Bias oscillation control output. "L" : ON
29	NC	-	GND.
30	DAT FUNC	O	DAT mute output.
31	CD FUNC	O	CD mute output.
32	PASS	O	PASS amplifier switch output to dolby.
33	EQ H/L	O	REC equalizer switching output. "L" : High speed "H" : Normal speed
34	REC MUTE	O	REC mute output.
35	PB SEL	O	Play mode deck A/B select output. "L" : DECK A "H" : DECK B
36	AMS G SEL	O	AMS/BS mode select output. "H" : AMS mode "L" : BS mode
37	1599 MUTE	O	Mute output to IC101 (CXA1599Q). "H" : ON "L" : OFF
38	NC	-	Not used. (OPEN)
39	NR RELAY	O	ALC control output.
40	CD SYNC	O	Not used. (OPEN)

	FF	TRIG	STOP	FWD
REEL 1	H	L	L	H
REEL 2	L	H	L	L
REEL 3	H	H	L	L



Pin No.	Pin name	I/O	Description
41	DUB H	O	Not used. (OPEN)
42	DUB N	O	Not used. (OPEN)
43	PAUSE	O	Not used. (OPEN)
44	REC	O	Not used. (OPEN)
45	B ◁	O	Not used. (OPEN)
46	B ▷	O	Not used. (OPEN)
47	A ◁	O	Not used. (OPEN)
48	A ▷	O	Not used. (OPEN)
49	B STOP SW	I	Deck B stop detect input. "H" : STOP
50	A STOP SW	I	Deck A stop detect input. "H" : STOP
51	+7.5V DET	I	+7.5V power supply detect input.
52	RELAY	O	Control output to REC/PB select output. "H" : REC "L" : PLAY
53	REC/PB	O	Dolby IC (IC103) REC/PB select output. "H" : REC "L" : PLAY
54	CAP. MOT H/L	O	Capstan motor HIGH/LOW select output. "H" : HIGH "L" : LOW
55	B CAP. MOTOR	O	Deck B capstan motor control output. "H" : ON "L" : OFF
56	A CAP. MOTOR	O	Deck A capstan motor control output. "H" : ON "L" : OFF
57	V <sub>DD</sub>	-	+5V power supply.
58	VEE	-	GND.
59	AV <sub>SS</sub>	-	GND.
60	VREF	I	A/D converter reference power supply +5V.
61	A HALF	I	Deck A half detect input.
62	BS. REEL IN	I	Deck B reel table signal input.
63	AS. REEL IN	I	Deck A reel table signal input.
64	AMS IN	I	AMS input. "L" : No song "H" : Song

**IC301 M38122M2-102FP FL DRIVE (PANEL BOARD)**

Pin No.	Pin name	I/O	Description
1	KEY3	I	Not used. (OPEN)
2	KEY2	I	Key input. (A/D converter analog input)
3	KEY1		
4	KEY0		
5	ALL ON	I	Not used. (+5V)
6	TEST MODE	I	Not used. (+5V)
7	VERSION	I	Not used. (+5V)
8	CLOCK	I	Clock input from IC104 (M38123M4-118FP)
9	DATA OUT	O	Data output to IC104 (M38123M4-118FP)
10	DATA IN	I	Data input from IC104 (M38123M4-118FP)
11	————	—	Not used. (OPEN)
12	————	—	Not used. (OPEN)
13	————	—	Not used. (OPEN)
14	————	—	Not used. (+5V)
15	————	—	Not used. (OPEN)
16	————	—	Not used. (OPEN)
17	MASTER SYNC	I	SYNC input from IC104 (M38123M4-118FP)
18	SIRCS	I	Not used. (OPEN)
19	RESET	I	Reset signal input.
20	————	—	Not used. (OPEN)
21	————	—	Not used. (OPEN)
22	X IN	I	Oscillator connection pins. (4MHz)
23	X OUT	O	
24	V <sub>ss</sub>	—	GND.
25	————	—	Not used. (OPEN)
26	————	—	Not used. (OPEN)
27	————	—	Not used. (OPEN)
28	————	—	Not used. (OPEN)
29 – 48	P20 – P1	O	FL tube segment output.
49 – 54	1G – 6G	O	FL tube digital output.
55	————	—	Not used. (OPEN)
56	————	—	Not used. (OPEN)
57	V <sub>cc</sub>	—	+5V power supply.
58	VEE	—	Minus voltage for FL tube.
59	AV <sub>ss</sub>	—	GND
60	VREF	—	A/D converter reference power supply +5V.
61	————	—	Not used. (OPEN)
62	————	—	Not used. (OPEN)
63	————	—	Not used. (OPEN)
64	————	—	Not used. (OPEN)

SECTION 4  
DIAGRAMS

4-1. BLOCK DIAGRAM

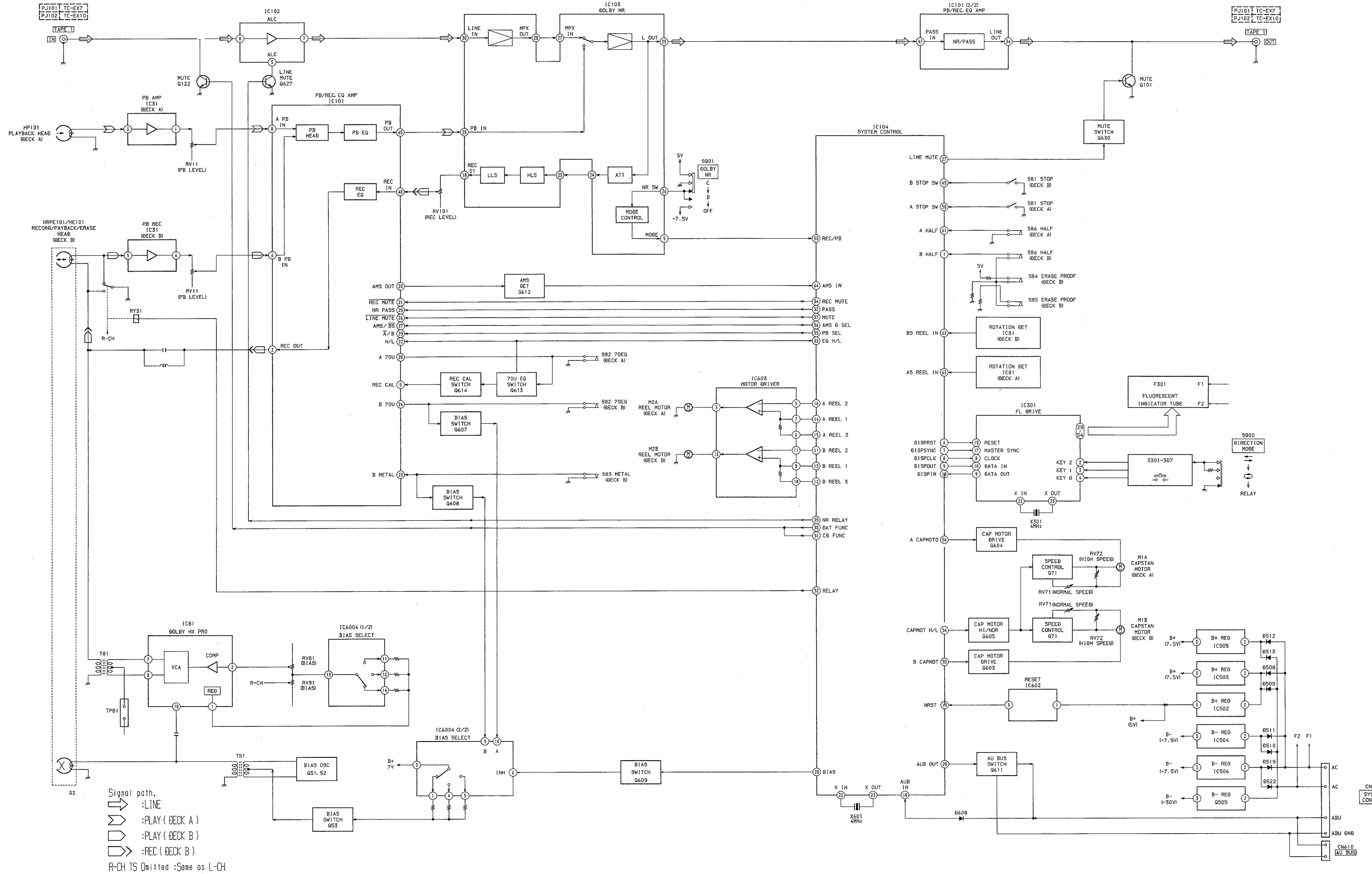

● CIRCUIT BOARD LOCATION

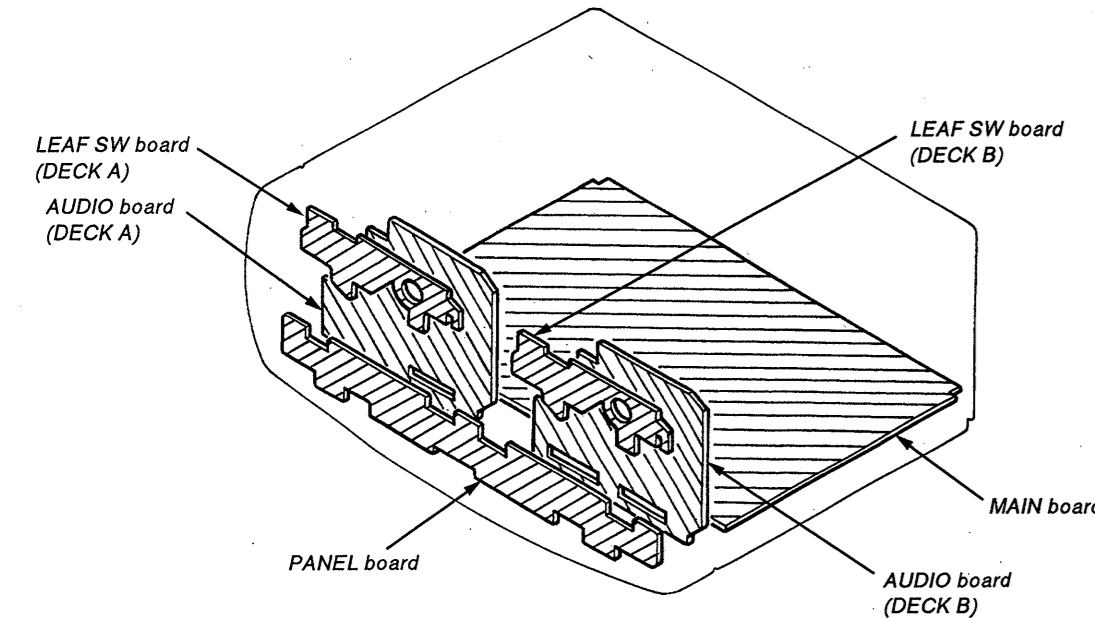

● SEMICONDUCTOR LOCATION

Ref. No.	Location	Ref. No.	Location
D31	I-3	IC101	E-15
D508	C-22	IC102	C-16
D509	C-22	IC103	C-15
D510	C-21	IC104	E-22
D511	C-21	IC301	J-18
D512	C-20	IC502	C-23
D513	C-20	IC503	D-22
D515	B-22	IC504	D-20
D516	B-22	IC505	D-19
D517	B-23	IC506	D-19
D518	C-24	IC602	F-23
D519	C-20	IC603	E-19
D520	D-24	IC6004	G-17
D521	D-24		
D522	C-20		
D523	D-22	Q51	H-3
D524	D-20	Q52	H-3
D525	B-19	Q53	H-3
D526	B-19	Q71	C-5
D527	D-19		(AUDIO DECK A)
D528	D-19		(AUDIO DECK B)
D601	E-23		
D602	E-23		
D603	H-21	Q101	D-16
D604	H-21	Q122	C-18
D605	E-18	Q201	D-16
D606	F-19	Q222	B-15
D607	D-16	Q505	B-23
D608	D-23		
D609	D-23	Q603	H-19
D610	F-19	Q604	H-21
D611	E-22	Q605	G-21
D620	E-19	Q607	G-18
IC31	D-3 (AUDIO DECK A)	Q609	G-18
	I-3 (AUDIO DECK B)	Q611	D-23
	H-4 (AUDIO DECK B)	Q612	D-16
	C-11 (LEAF SW DECK A)	Q613	E-17
	H-11 (LEAF SW DECK B)	Q614	E-17
		Q627	C-17
IC81		Q630	D-17

Note:

- : parts extracted from the component side.
- : Through hole.
- ▨ : Pattern on the side which is seen.
- ▩ : Pattern of the rear side.
- Abbreviation  
 CND : Canadian  
 G : German  
 IT : Italian  
 AUS : Australian  
 EA : Saudi Arabia

4-2. PRINTED WIRING BOARDS

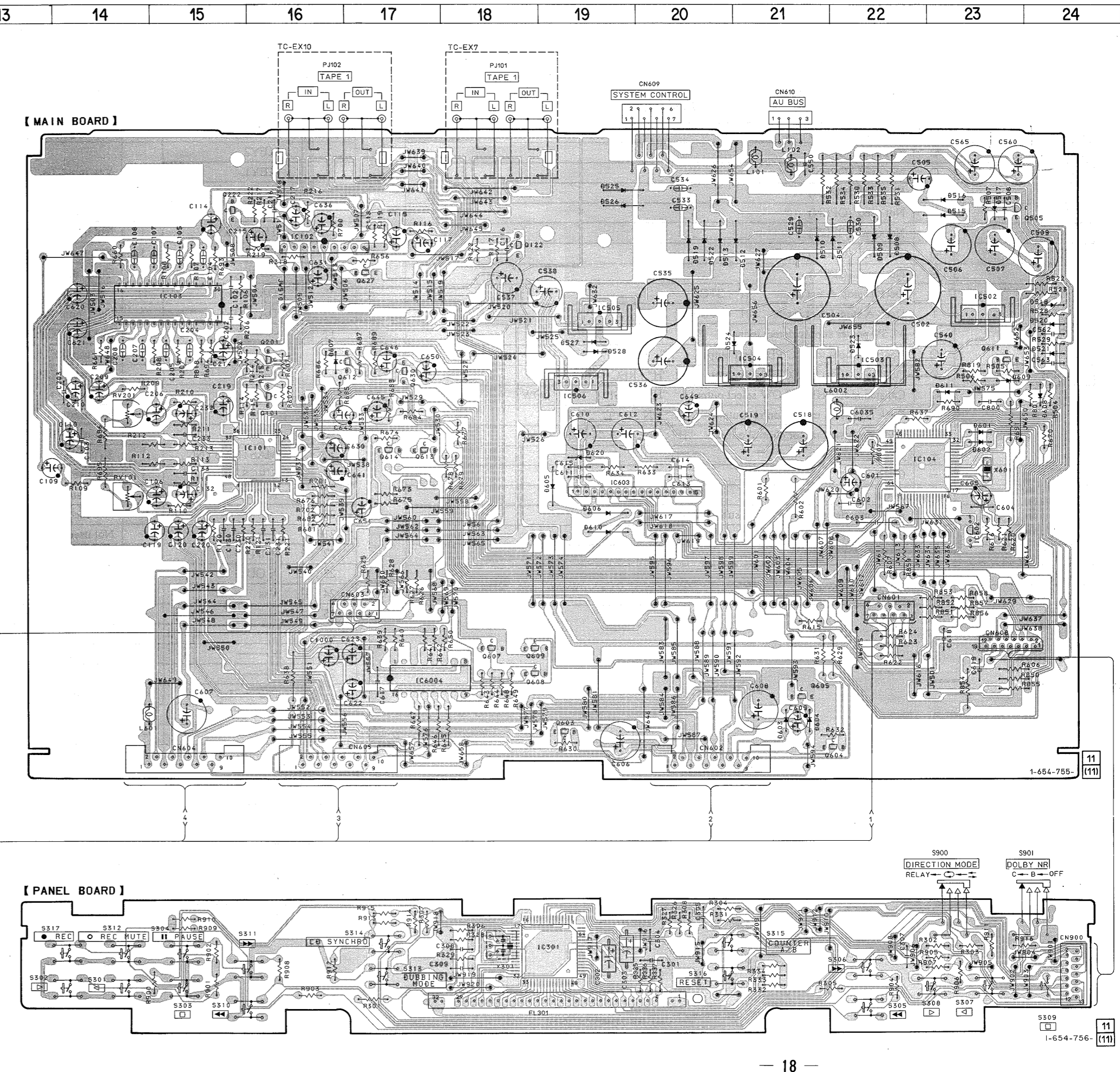
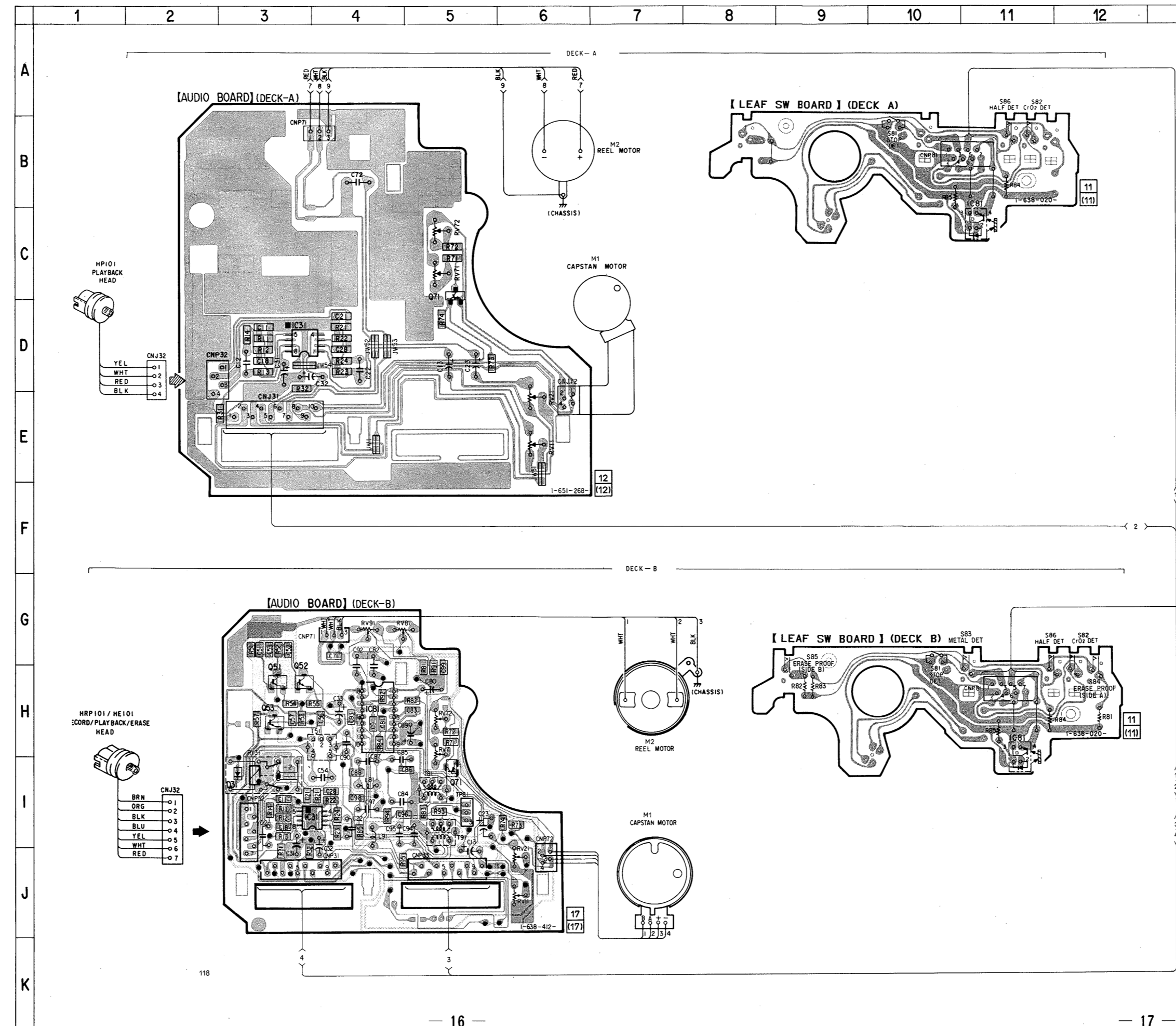

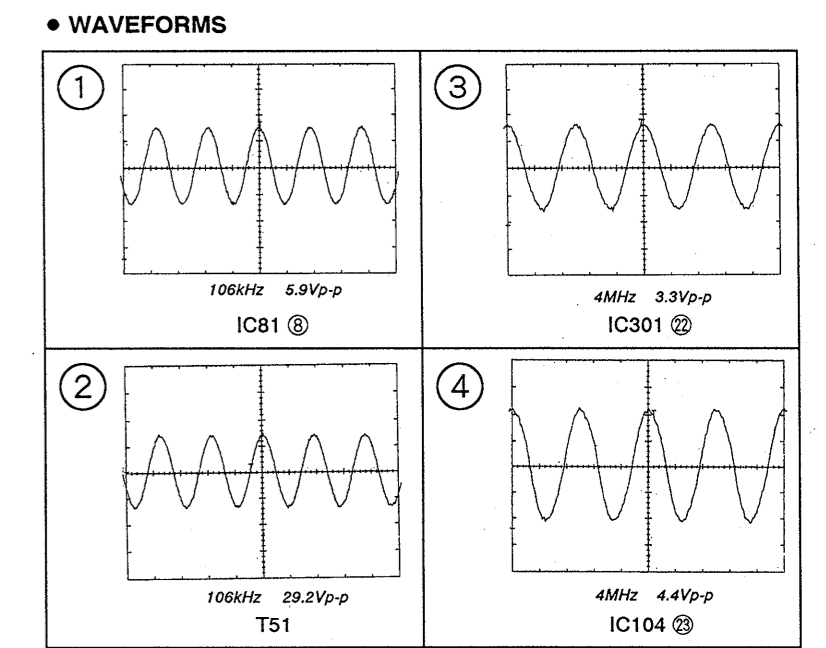
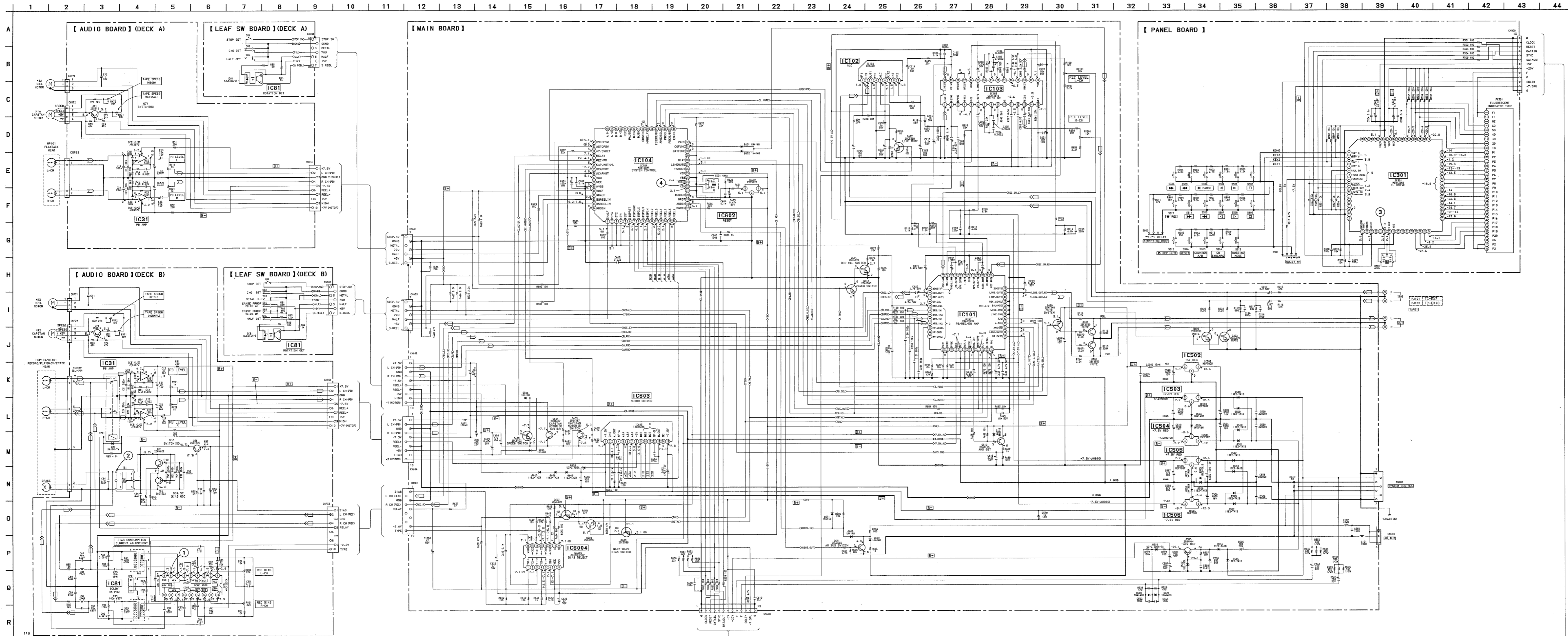

Note :

- All capacitors are in  $\mu F$  unless otherwise noted. pF:  $\mu F$  50WV or less are not indicated except for electrolytics and tantalums.
- All resistors are in  $\Omega$  and  $\frac{1}{4}W$  or less unless otherwise specified.
- $\Delta$  : internal component.
- B+** : B+ Line
- B-** : B- Line
- $\square$  : adjustment for repair.
- Voltage and waveforms are dc with respect to ground under no-signal (detuned) conditions.
- no mark : STOP
- ( ) : REC
- Voltages are taken with a VOM ( Input impedance 10M  $\Omega$  ). Voltage variations may be noted due to normal production tolerances.
- Waveforms are taken with a oscilloscope. Voltage variations may be noted due to normal production tolerances.
- Circled numbers refer to waveforms.
- Signal path.
  - $\square$  : PB ( DECK A )
  - $\square$  : PB ( DECK B )
  - $\square$  : REC ( DECK B )
- Abbreviation
  - CND : Canadian
  - G : German
  - IT : Italian
  - AUS : Australian
  - EA : Saudi Arabia

● IC BLOCK DIAGRAMS

IC101 CXA1599Q

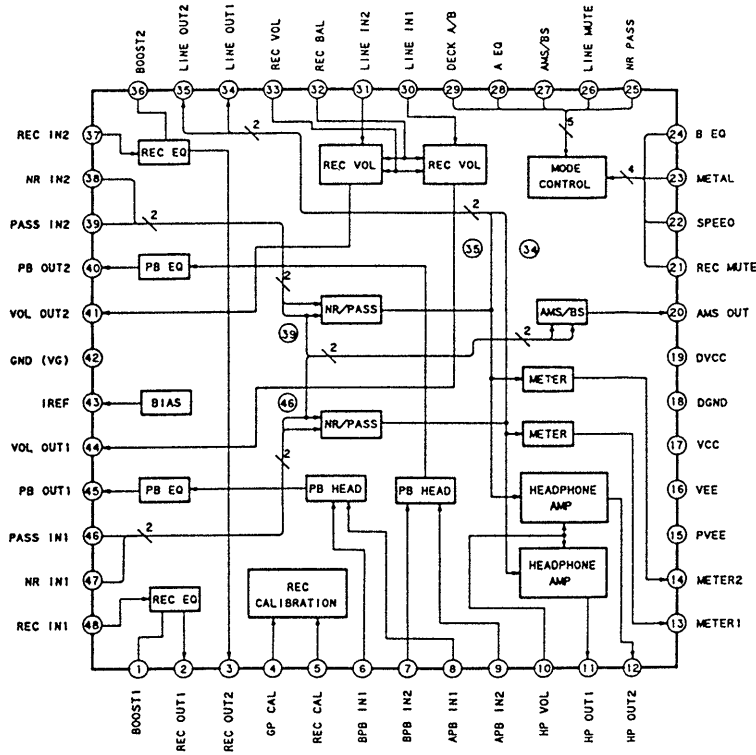

IC102 BA3308

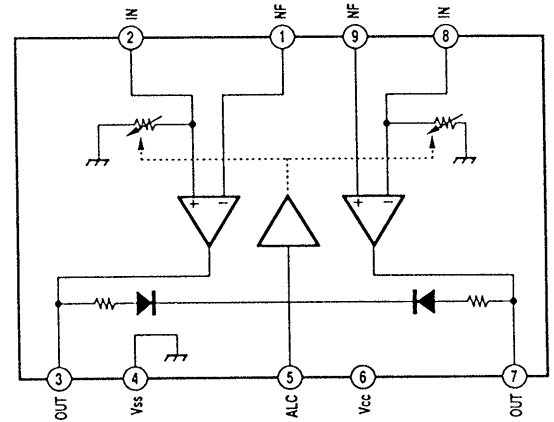

IC103 CXA1331S

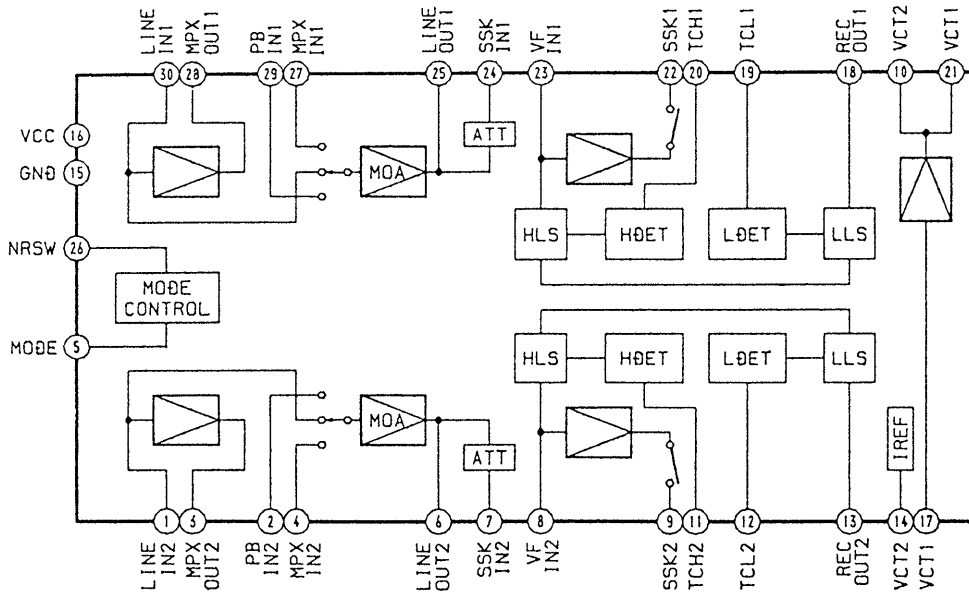

IC603 TA8242AK

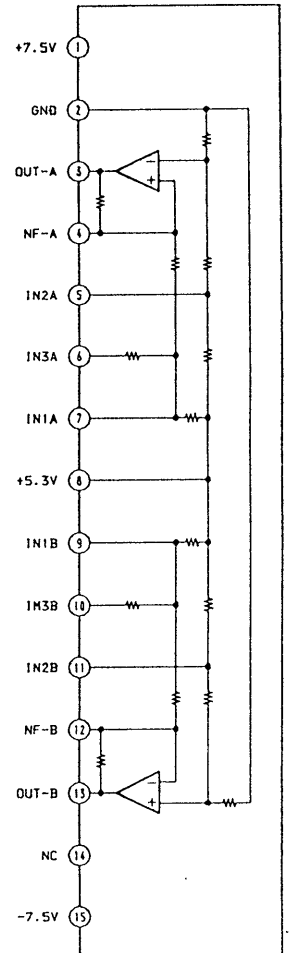

## SECTION 5 EXPLODED VIEWS

**NOTE :**

- -XX, -X mean standardized parts, so they may have some difference from the original one.
- The construction parts of an assembled part are indicated with a collation number in the remark column.

- Items marked “ \* ” are not stocked since they are seldom required for routine service. Some delay should be anticipated when ordering these items.
- The mechanical parts with no reference number in the exploded views are not supplied.
- Hardware ( # mark) list and accessories and packing materials are given in the last of this parts list.

### 5-1. CHASSIS SECTION

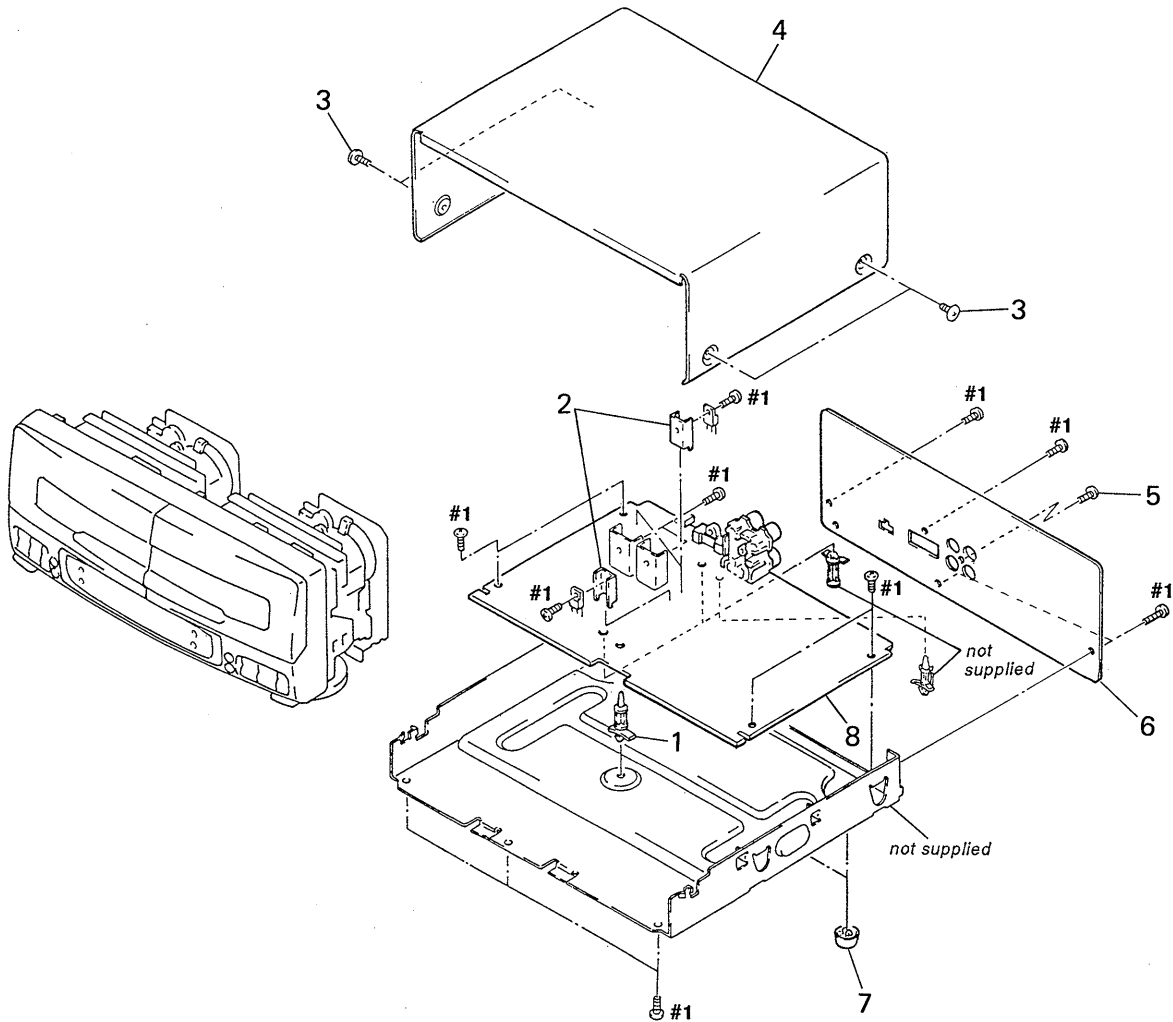

Ref. No.	Part No.	Description	Remark	Ref. No.	Part No.	Description	Remark
* 1	3-349-025-41	HOLDER, PC BOARD		* 6	3-919-578-11	PANEL, BACK (EX7)	
* 2	3-309-144-21	HEAT SINK		* 6	3-919-578-21	PANEL, BACK (EX10)	
3	3-363-099-01	SCREW (CASE 3 TP2)		7	4-965-822-01	FOOT	
4	3-919-558-11	CASE		* 8	A-2007-303-A	MAIN BOARD, COMPLETE (EX10)	
5	3-704-515-01	SCREW (BV/RING)		* 8	A-2007-305-A	MAIN BOARD, COMPLETE (EX7)	

## 5-2. FRONT PANEL SECTION

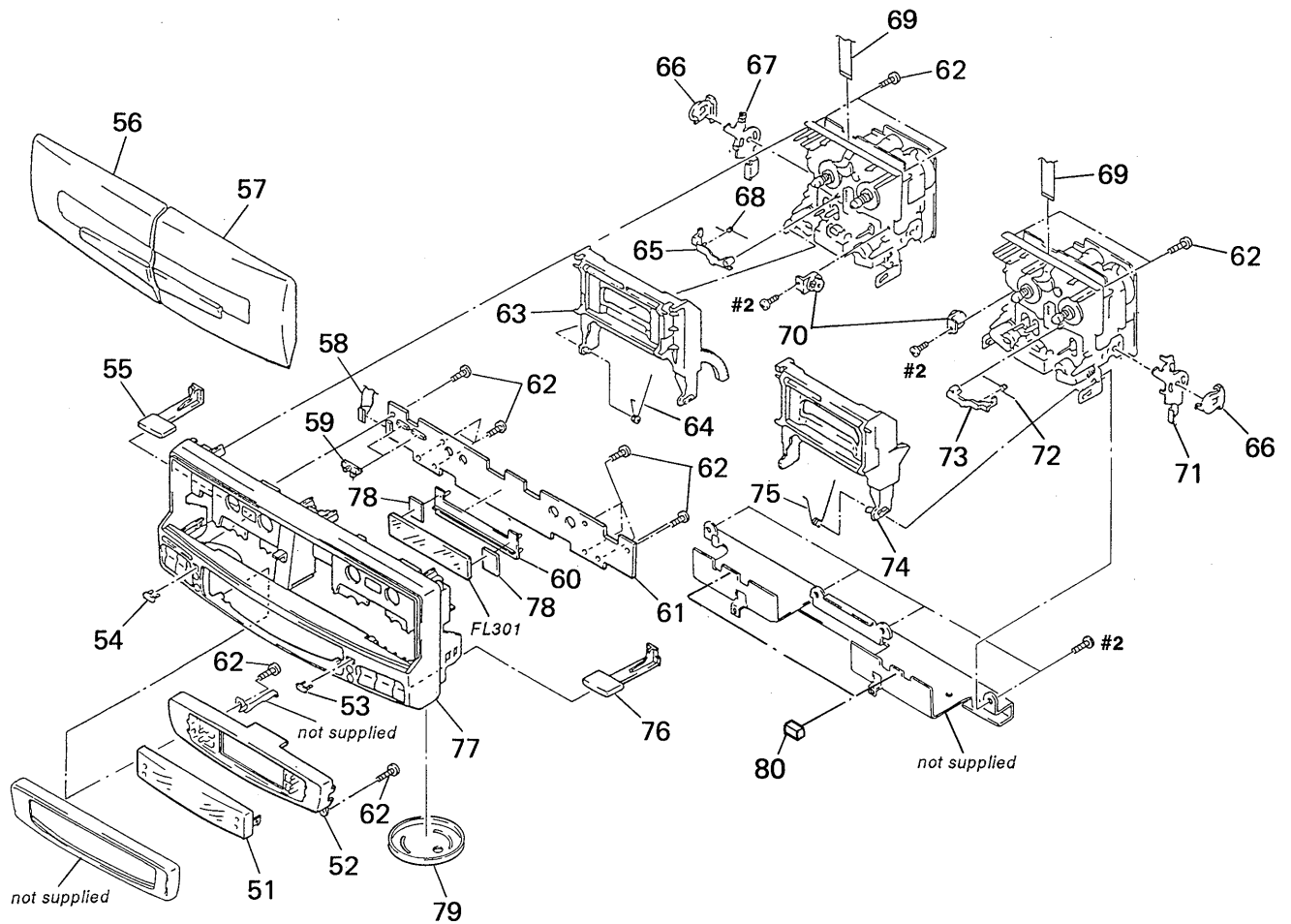

Ref. No.	Part No.	Description	Remark	Ref. No.	Part No.	Description	Remark
51	3-919-555-01	WINDOW (DISPLAY)		66	3-354-957-01	JOINT (LOCK LEVER)	
52	3-919-556-01	BASE, WINDOW		* 67	3-354-953-01	LEVER (LOCK LEVER L)	
53	3-919-573-01	COVER (AZIMUTH B)		68	3-354-961-01	SPRING (EJ SAFTY SPRING L)	
54	3-919-572-01	COVER (AZIMUTH A)		69	1-765-384-11	WIRE (FLAT TYPE) (7 CORE)	
55	3-919-574-01	SLIDER (L)		70	3-354-963-01	DAMPER	
56	X-3369-490-1	LID (A) ASSY, CASSETTE		* 71	3-354-954-01	LEVER (LOCK LEVER R)	
57	X-3369-495-1	LID (B) ASSY, CASSETTE		72	3-354-962-01	SPRING (EJ SAFTY SPRING R)	
58	1-769-391-11	WIRE (FLAT TYPE) (13 CORE)		73	3-354-956-01	LEVER (EJ SAFTY LEVER R)	
59	3-919-576-01	KNOB (SLIDE)		74	X-3369-494-1	HOLDER (R) ASSY, CASSETTE	
* 60	3-919-591-01	HOLDER (FL TUBE)		75	4-959-232-01	SPRING (R), TORSION	
* 61	A-2007-304-A	PANEL BOARD, COMPLETE (EX10)		76	3-919-575-01	SLIDER (R)	
* 61	A-2007-306-A	PANEL BOARD, COMPLETE (EX7)		77	X-3369-492-2	PANEL ASSY, FRONT	
62	4-951-620-01	SCREW (2.6×8), +BVTP		* 78	4-932-810-11	CUSHION (FL)	
63	X-3369-493-1	HOLDER (L) ASSY, CASSETTE		79	4-972-656-01	FOOT (ORNAMENT)	
64	4-959-231-01	SPRING (L), TORSION		80	3-926-057-01	CUSHION (TCM)	
65	3-354-955-01	LEVER (EJ SAFTY LEVER L)		FL301	1-517-370-11	INDICATOR TUBE, FLUORESCENT	



**5-3. MECHANISM SECTION-1**  
**(DECK A : TCM-190RA12CL)**  
**(DECK B : TCM-190RB12CL)**

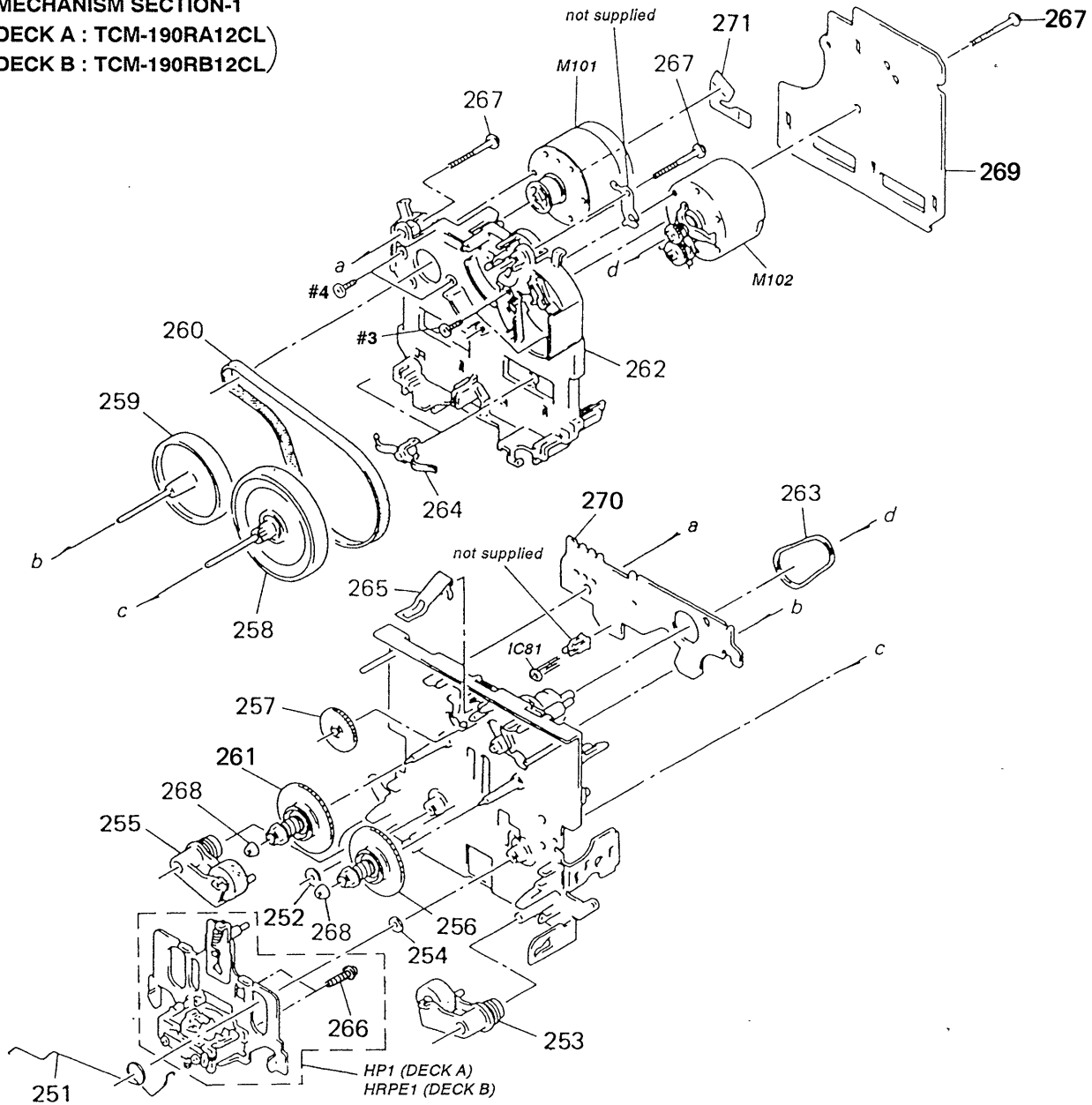

Ref.No.	Part No.	Description	Remark	Ref.No.	Part No.	Description	Remark
251	3-907-362-01	SPRING, TORSION		263	3-359-466-01	BELT (FR), SQUARE	
252	3-356-714-01	WASHER		264	3-575-321-00	RETAINER, THRUST, CAPSTAN	
253	X-3366-047-1	LEVER (PINCH F) ASSY		265	3-359-430-01	SPRING(CASSETTE RETAINER), LEAF	
254	3-356-713-01	WASHER		266	3-388-848-01	SCREW (P2×6) (B TIGHT)	
255	X-3366-048-1	LEVER (PINCH R) ASSY		267	3-359-414-01	SCREW (+PTPWH 2×23)	
256	X-3366-971-1	TABLE (B) ASSY, REEL (DECK A)		268	3-362-308-01	CAP (REEL)	
256	X-3369-508-1	TABLE (C) ASSY, REEL (DECK B)		* 269	A-2007-040-A	AUDIO BOARD, COMPLETE (DECK B)	
257	3-359-424-01	GEAR (REV GEAR)		* 269	A-2007-266-A	AUDIO BOARD, COMPLETE (DECK A)	
258	X-3367-629-1	FLYWHEEL (FWD) ASSY		* 270	1-638-020-11	LEAF SW BOARD	
259	X-3359-410-1	FLYWHEEL (REV) ASSY (DECK A)		271	1-638-983-11	MOTOR FLEXIBLE BOARD	
259	X-3367-630-1	FLYWHEEL (REV) ASSY (DECK B)		HP1	A-2003-757-A	BASE ASSY, HEAD (PB) (DECK A)	
260	3-359-417-01	BELT (FLAT), CAPSTAN		HRPE1	A-2003-930-A	BASE ASSY, HEAD (PB/REC/ERASE) (DECK B)	
261	X-3366-970-1	TABLE ASSY, REEL		M101	X-3365-377-2	MOTOR ASSY (CAPSTAN)	
262	3-359-436-11	BASE (THRUST RETAINER), FITTING		M202	X-3365-501-2	MOTOR ASSY (REEL)	

**5-4. MECHANISM SECTION-2**  
**( DECK A : TCM-190RA12CL )**  
**( DECK B : TCM-190RB12CL )**

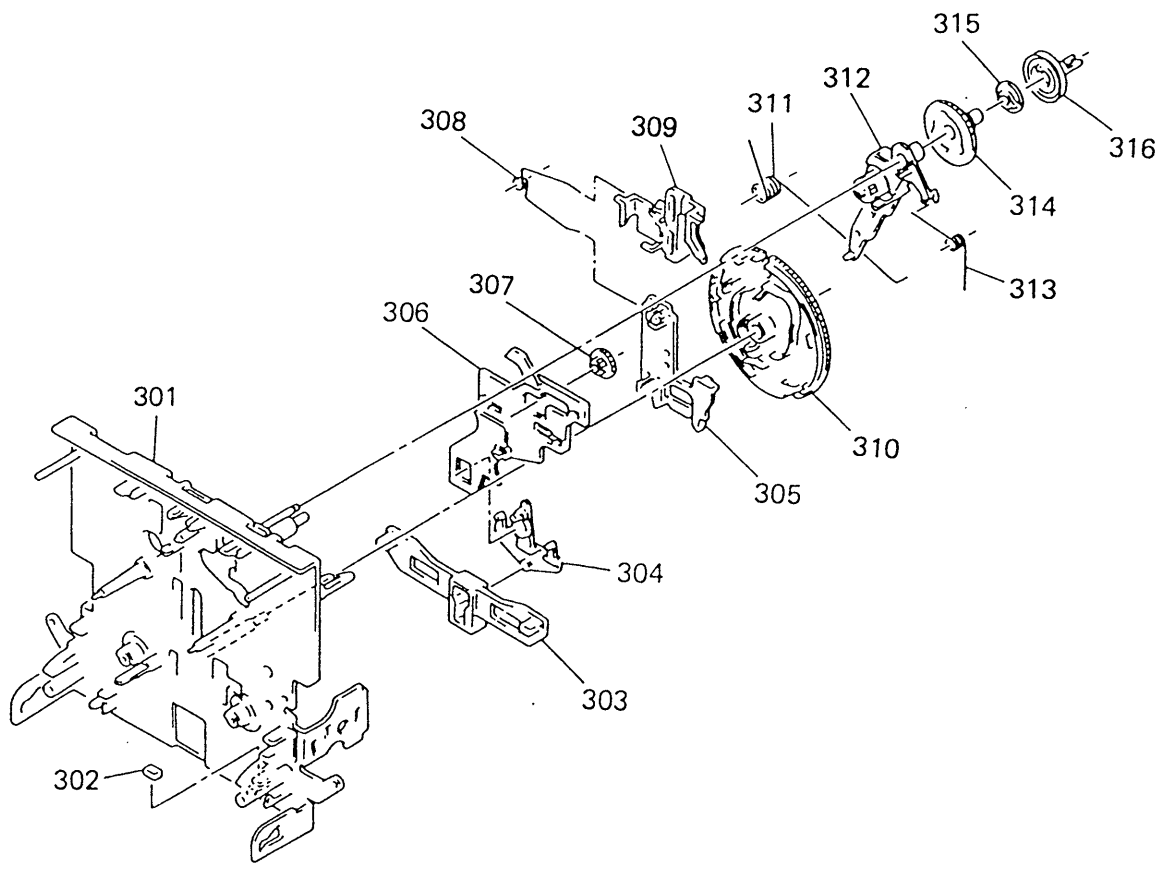

<u>Ref. No.</u>	<u>Part No.</u>	<u>Description</u>	<u>Remark</u>	<u>Ref. No.</u>	<u>Part No.</u>	<u>Description</u>	<u>Remark</u>
301	X-3359-415-1	CHASSIS ASSY, MECHANICAL		309	3-359-429-01	SLIDER (BRAKE PLATE)	
302	3-359-469-01	SPACER		310	3-359-420-01	GEAR (CAM GEAR)	
303	3-359-425-01	SLIDER (REVERSE SLIDER)		311	3-359-456-01	SPRING (TRIGGER SPRING), TORSION	
304	3-359-426-01	LEVER (REVERSE LEVER)		312	X-3366-569-1	ARM ASSY, FR	
305	3-359-427-01	SLIDER (LEVERSE SLIDER)		313	3-924-185-11	SPRING (FR ARM), TORSION	
* 306	3-359-415-01	SLIDER (TRIGGER SLIDER)		314	3-359-419-11	GEAR (FR GEAR)	
307	3-359-448-01	GEAR (TRIGGER)		315	3-359-421-01	CLUTCH (REEL DISK)	
308	3-359-454-01	SPRING, TORSION		316	3-359-418-01	PULLEY (FR PULLEY)	

## SECTION 6 ELECTRICAL PARTS LIST

### AUDIO (DECK A)

### AUDIO (DECK B)

**NOTE :**

- Due to standardization, replacements in the parts list may be different from the parts specified in the diagrams or the components used on the set.
- -XX, -X mean standardized parts, so they may have some difference from the original one.
- RESISTORS  
All resistors are in ohms  
METAL : Metal-film resistor  
METAL OXIDE : Metal oxide-film resistor  
F : Nonflammable

- Items marked " \* " are not stocked since they are seldom required for routine service. Some delay should be anticipated when ordering these items.
- SEMICONDUCTORS  
In each case, u :  $\mu$ , for example :  
uA.... :  $\mu$  A...., uPA.... :  $\mu$  PA....  
uPB.... :  $\mu$  PB...., uPC.... :  $\mu$  PC....  
uPD.... :  $\mu$  PD....
- CAPACITORS  
uF :  $\mu$  F
- COILS  
uH :  $\mu$  H

When indicating parts by reference number, please include the board.

Ref. No.	Part No.	Description	Remark
*	A-2007-266-A	AUDIO BOARD, COMPLETE (DECK A) *****	
		< CAPACITOR >	
C11	1-163-131-00	CERAMIC CHIP 390PF	5% 50V
C12	1-136-157-00	FILM 0.022uF	5% 50V
C13	1-124-234-00	ELECT 22uF	20% 16V
C18	1-163-117-00	CERAMIC CHIP 100PF	5% 50V
C21	1-163-131-00	CERAMIC CHIP 390PF	5% 50V
C22	1-136-157-00	FILM 0.022uF	5% 50V
C23	1-124-234-00	ELECT 22uF	20% 16V
C28	1-163-117-00	CERAMIC CHIP 100PF	5% 50V
C31	1-124-234-00	ELECT 22uF	20% 16V
C32	1-124-234-00	ELECT 22uF	20% 16V
C72	1-124-499-11	ELECT, NONPOLAR 1uF	20% 50V
		< CONNECTOR >	
* CNJ31	1-580-782-11	CONNECTOR, BOARD TO BOARD	
CNJ72	1-764-902-11	CONNECTOR, FPC/FPC 4P	
* CNP32	1-580-772-11	PIN, CONNECTOR (PC BOARD) 4P	
* CNP71	1-564-719-11	PIN, CONNECTOR (SMALL TYPE) 3P	
		< IC >	
IC31	8-759-106-02	IC uPC4570G2	
		< JUMPER RESISTOR >	
JW1	1-216-295-91	METAL CHIP 0	5% 1/10W
JW51-54	1-216-296-00	METAL CHIP 0	5% 1/8W
		< TRANSISTOR >	
Q71	8-729-216-22	TRANSISTOR 2SA1162-G	
		< RESISTOR >	
R11	1-216-099-00	METAL CHIP 120K	5% 1/10W
R12	1-216-025-91	METAL GLAZE 100	5% 1/10W
R13	1-216-100-00	METAL GLAZE 130K	5% 1/10W
R14	1-216-068-00	METAL CHIP 6.2K	5% 1/10W
R21	1-216-099-00	METAL CHIP 120K	5% 1/10W

Ref. No.	Part No.	Description	Remark
R22	1-216-025-91	METAL GLAZE 100	5% 1/10W
R23	1-216-100-00	METAL GLAZE 130K	5% 1/10W
R24	1-216-068-00	METAL CHIP 6.2K	5% 1/10W
R31	1-216-033-00	METAL CHIP 220	5% 1/10W
R32	1-216-033-00	METAL CHIP 220	5% 1/10W
R71	1-216-082-00	METAL GLAZE 24K	5% 1/10W
R72	1-216-081-00	METAL CHIP 22K	5% 1/10W
R73	1-216-089-00	METAL CHIP 47K	5% 1/10W
R74	1-216-089-00	METAL CHIP 47K	5% 1/10W
		< VARIABLE RESISTOR >	
RV11	1-241-761-11	RES, ADJ, CARBON 1K (PLAYBACK LEVEL L)	
RV21	1-241-761-11	RES, ADJ, CARBON 1K (PLAYBACK LEVEL R)	
RV71	1-241-630-11	RES, ADJ, CARBON 10K (TAPE SPEED NOR)	
RV72	1-241-630-11	RES, ADJ, CARBON 10K (TAPE SPEED HI)	
*****			
*	A-2007-040-A	AUDIO BOARD, COMPLETE (DECK B) *****	
		< CAPACITOR >	
C11	1-163-131-00	CERAMIC CHIP 390PF	5% 50V
C12	1-136-157-00	FILM 0.022uF	5% 50V
C13	1-124-234-00	ELECT 22uF	20% 16V
C18	1-163-117-00	CERAMIC CHIP 100PF	5% 50V
C21	1-163-131-00	CERAMIC CHIP 390PF	5% 50V
C22	1-136-157-00	FILM 0.022uF	5% 50V
C23	1-124-234-00	ELECT 22uF	20% 16V
C28	1-163-117-00	CERAMIC CHIP 100PF	5% 50V
C31	1-124-234-00	ELECT 22uF	20% 16V
C32	1-124-234-00	ELECT 22uF	20% 16V
C33	1-124-234-00	ELECT 22uF	20% 16V
C51	1-164-161-11	CERAMIC CHIP 0.0022uF	10% 100V
C52	1-164-161-11	CERAMIC CHIP 0.0022uF	10% 100V
C53	1-163-019-00	CERAMIC CHIP 0.0068uF	10% 50V
C54	1-136-601-11	FILM 0.01uF	5% 630V
C56	1-164-505-11	CERAMIC CHIP 2.2uF	16V
C57	1-164-346-11	CERAMIC CHIP 1uF	16V
C71	1-164-346-11	CERAMIC CHIP 1uF	16V
C80	1-124-234-00	ELECT 22uF	20% 16V
C81	1-164-232-11	CERAMIC CHIP 0.01uF	50V

# AUDIO (DECK B)

Ref. No.	Part No.	Description	Remark
C82	1-136-157-00	FILM 0.022uF	5% 50V
C83	1-164-004-11	CERAMIC CHIP 0.1uF	10% 25V
C84	1-136-478-11	FILM 470PF	5% 630V
C85	1-136-433-11	FILM 100PF	5% 630V
C86	1-163-143-00	CERAMIC CHIP 0.0012uF	5% 50V
C87	1-136-273-91	FILM 75PF	5% 630V
C88	1-163-003-11	CERAMIC CHIP 330PF	10% 50V
C89	1-124-234-00	ELECT 22uF	20% 16V
C90	1-107-584-11	CERAMIC 4PF	0.25PF 500V
C91	1-164-232-11	CERAMIC CHIP 0.01uF	50V
C92	1-136-157-00	FILM 0.022uF	5% 50V
C93	1-164-004-11	CERAMIC CHIP 0.1uF	10% 25V
C94	1-136-478-11	FILM 470PF	5% 630V
C95	1-136-433-11	FILM 100PF	5% 630V
C96	1-163-143-00	CERAMIC CHIP 0.0012uF	5% 50V
C97	1-136-273-91	FILM 75PF	5% 630V
C98	1-163-003-11	CERAMIC CHIP 330PF	10% 50V
C99	1-164-005-11	CERAMIC CHIP 0.47uF	25V
< CONNECTOR >			
* CNP31	1-580-782-11	CONNECTOR, BOARD TO BOARD	
* CNP32	1-580-781-11	PIN, CONNECTOR (PC BOARD) 7P	
* CNP33	1-580-782-11	CONNECTOR, BOARD TO BOARD	
* CNP71	1-564-719-11	PIN, CONNECTOR (SMALL TYPE) 3P	
CNP72	1-764-902-11	CONNECTOR, FPC/FPC 4P	
* CNP75	1-564-718-11	PIN, CONNECTOR (SMALL TYPE) 2P	
< DIODE >			
D31	8-719-404-46	DIODE MA110	
< IC >			
IC31	8-759-106-02	IC uPC4570G2	
IC81	8-759-106-56	IC uPC1297CA	
< COIL >			
L81	1-410-780-11	INDUCTOR 27mH	
L91	1-410-780-11	INDUCTOR 27mH	
< TRANSISTOR >			
Q51-53	8-729-808-01	TRANSISTOR 2SD1622-S	
Q71	8-729-216-22	TRANSISTOR 2SA1162-G	
< RESISTOR >			
R11	1-216-099-00	METAL CHIP 120K 5%	1/10W
R12	1-216-025-91	METAL GLAZE 100 5%	1/10W
R13	1-216-100-00	METAL GLAZE 130K 5%	1/10W
R14	1-216-067-00	METAL CHIP 5.6K 5%	1/10W
R21	1-216-099-00	METAL CHIP 120K 5%	1/10W

Ref. No.	Part No.	Description	Remark
R22	1-216-025-91	METAL GLAZE 100 5%	1/10W
R23	1-216-100-00	METAL GLAZE 130K 5%	1/10W
R24	1-216-067-00	METAL CHIP 5.6K 5%	1/10W
R31	1-216-033-00	METAL CHIP 220 5%	1/10W
R32	1-216-033-00	METAL CHIP 220 5%	1/10W
R33	1-216-065-00	METAL CHIP 4.7K 5%	1/10W
R51	1-216-097-00	METAL CHIP 100K 5%	1/10W
R52	1-216-097-00	METAL CHIP 100K 5%	1/10W
R53	1-216-073-00	METAL CHIP 10K 5%	1/10W
R54	1-216-309-00	METAL CHIP 5.6 5%	1/10W
R55	1-216-309-00	METAL CHIP 5.6 5%	1/10W
R57	1-216-298-00	METAL CHIP 2.2 5%	1/10W
R71	1-216-082-00	METAL GLAZE 24K 5%	1/10W
R72	1-216-081-00	METAL CHIP 22K 5%	1/10W
R73	1-216-089-00	METAL CHIP 47K 5%	1/10W
R74	1-216-089-00	METAL CHIP 47K 5%	1/10W
R81	1-216-073-00	METAL CHIP 10K 5%	1/10W
R82	1-216-085-00	METAL CHIP 33K 5%	1/10W
R83	1-216-001-00	METAL CHIP 10 5%	1/10W
R84	1-216-101-00	METAL CHIP 150K 5%	1/10W
R85	1-216-075-00	METAL CHIP 12K 5%	1/10W
R91	1-216-073-00	METAL CHIP 10K 5%	1/10W
R92	1-216-085-00	METAL CHIP 33K 5%	1/10W
R93	1-216-001-00	METAL CHIP 10 5%	1/10W
R94	1-216-101-00	METAL CHIP 150K 5%	1/10W
R95	1-216-075-00	METAL CHIP 12K 5%	1/10W
< VARIABLE RESISTOR >			
RV11	1-241-761-11	RES, ADJ, CARBON 1K (PLAYBACK LEVEL L)	
RV21	1-241-761-11	RES, ADJ, CARBON 1K (PLAYBACK LEVEL R)	
RV71	1-241-630-11	RES, ADJ, CARBON 10K (TAPE SPEED NOR)	
RV72	1-241-630-11	RES, ADJ, CARBON 10K (TAPE SPEED HI)	
RV81	1-241-786-11	RES, ADJ, CARBON 22K (REC BIAS L)	
RV91	1-241-786-11	RES, ADJ, CARBON 22K (REC BIAS R)	
< RELAY >			
RY31	1-515-913-11	RELAY	
< TRANSFORMER >			
T51	1-406-417-11	COIL, BIAS OSCILLATION	
T81	1-433-381-11	TRANSFORMER, BIAS OSCILLATOR	
T91	1-433-381-11	TRANSFORMER, BIAS OSCILLATOR	
< TEST PIN >			
* TP81	1-568-449-11	HOUSING, CONNECTOR (PC BOARD) 3P	
*****			

# LEAF SW (DECK A)

# LEAF SW (DECK B)

# MAIN

Ref. No.	Part No.	Description	Remark
*	1-638-020-11	LEAF SW BOARD (DECK A) *****	
		< CONNECTOR >	
* CNP81	1-568-850-11	SOCKET, CONNECTOR 7P	
		< IC >	
IC81	8-749-924-10	IC PHONT REFLECTOR NJL5165K-B(H1)	
		< RESISTOR >	
R84	1-249-417-11	CARBON 1K 5% 1/4W	
R85	1-249-408-11	CARBON 180 5% 1/4W	
		< SWITCH >	
S81	1-571-958-11	SWITCH, PUSH (1 KEY) (STOP DET)	
S82	1-571-281-21	SWITCH, LEAF (CrO <sub>2</sub> )	
S86	1-571-281-21	SWITCH, LEAF (HALF DET)	
*****			
*	1-638-020-11	LEAF SW BOARD (DECK B) *****	
		< CONNECTOR >	
* CNP81	1-568-850-11	SOCKET, CONNECTOR 7P	
		< IC >	
IC81	8-749-924-10	IC PHONT REFLECTOR NJL5165K-B(H1)	
		< RESISTOR >	
R81	1-249-414-11	CARBON 560 5% 1/4W	
R82	1-247-818-11	CARBON 300 5% 1/4W	
R83	1-247-834-11	CARBON 1.3K 5% 1/4W	
R84	1-249-417-11	CARBON 1K 5% 1/4W	
R85	1-249-408-11	CARBON 180 5% 1/4W	
		< SWITCH >	
S81	1-571-958-11	SWITCH, PUSH (1 KEY) (STOP DET)	
S82	1-571-281-21	SWITCH, LEAF (CrO <sub>2</sub> )	
S83	1-571-281-21	SWITCH, LEAF (METAL DET)	
S84	1-571-281-21	SWITCH, LEAF (ERASE PROOF A)	
S85	1-571-281-21	SWITCH, LEAF (ERASE PROOF B)	
S86	1-571-281-21	SWITCH, LEAF (HALF DET)	
*****			

Ref. No.	Part No.	Description	Remark
*	A-2007-303-A	MAIN BOARD, COMPLETE (EX10)	
*	A-2007-305-A	MAIN BOARD, COMPLETE (EX7) *****	
		< CAPACITOR >	
C102	1-162-294-31	CERAMIC 0.001uF 10% 50V	
C103	1-162-282-31	CERAMIC 100PF 10% 50V	
C104	1-130-475-00	MYLAR 0.0022uF 5% 50V	
C105	1-130-475-00	MYLAR 0.0022uF 5% 50V	
C106	1-124-925-11	ELECT 2.2uF 20% 100V	
C107	1-136-174-00	FILM 0.56uF 5% 50V	
C108	1-136-171-00	FILM 0.33uF 5% 50V	
C109	1-124-925-11	ELECT 2.2uF 20% 100V	
C110	1-124-925-11	ELECT 2.2uF 20% 100V	
C114	1-124-907-11	ELECT 10uF 20% 50V	
C115	1-124-443-00	ELECT 100uF 20% 10V	
C116	1-162-282-31	CERAMIC 100PF 10% 50V	
C117	1-124-925-11	ELECT 2.2uF 20% 100V	
C119	1-124-902-00	ELECT 0.47uF 20% 50V	
C120	1-126-963-11	ELECT 4.7uF 20% 50V	
C130	1-162-282-31	CERAMIC 100PF 10% 50V	
C131	1-162-282-31	CERAMIC 100PF 10% 50V	
C132	1-124-903-11	ELECT 1uF 20% 50V	
C133	1-162-286-21	CERAMIC 220PF 10% 50V	
C202	1-162-294-31	CERAMIC 0.001uF 10% 50V	
C203	1-162-282-31	CERAMIC 100PF 10% 50V	
C204	1-130-475-00	MYLAR 0.0022uF 5% 50V	
C205	1-130-475-00	MYLAR 0.0022uF 5% 50V	
C206	1-124-925-11	ELECT 2.2uF 20% 100V	
C207	1-136-174-00	FILM 0.56uF 5% 50V	
C208	1-136-171-00	FILM 0.33uF 5% 50V	
C209	1-124-925-11	ELECT 2.2uF 20% 100V	
C210	1-124-925-11	ELECT 2.2uF 20% 100V	
C214	1-124-907-11	ELECT 10uF 20% 50V	
C215	1-124-443-00	ELECT 100uF 20% 10V	
C216	1-162-282-31	CERAMIC 100PF 10% 50V	
C217	1-124-925-11	ELECT 2.2uF 20% 100V	
C219	1-124-902-00	ELECT 0.47uF 20% 50V	
C220	1-126-963-11	ELECT 4.7uF 20% 50V	
C230	1-162-282-31	CERAMIC 100PF 10% 50V	
C231	1-162-282-31	CERAMIC 100PF 10% 50V	
C232	1-124-903-11	ELECT 1uF 20% 50V	
C233	1-162-286-21	CERAMIC 220PF 10% 50V	
C502	1-128-489-11	ELECT 3300uF 20% 16V	
C504	1-128-489-11	ELECT 3300uF 20% 16V	
C505	1-124-122-11	ELECT 100uF 20% 50V	
C506	1-124-920-11	ELECT 330uF 20% 50V	
C507	1-124-911-11	ELECT 220uF 20% 50V	
C508	1-162-306-11	CERAMIC 0.01uF 20% 16V	

Ref. No.	Part No.	Description	Remark
C509	1-124-911-11	ELECT	220uF 20% 50V
C518	1-126-927-11	ELECT	2200uF 20% 10V
C519	1-126-927-11	ELECT	2200uF 20% 10V
C529	1-136-157-00	FILM	0.022uF 5% 50V
C530	1-136-157-00	FILM	0.022uF 5% 50V
C533	1-136-157-00	FILM	0.022uF 5% 50V
C534	1-136-157-00	FILM	0.022uF 5% 50V
C535	1-126-942-61	ELECT	1000uF 20% 16V
C536	1-126-942-61	ELECT	1000uF 20% 16V
C537	1-124-472-11	ELECT	470uF 20% 10V
C538	1-124-472-11	ELECT	470uF 20% 10V
C540	1-124-473-11	ELECT	1000uF 20% 10V
C550	1-162-282-31	CERAMIC	100PF 10% 50V
C560	1-124-911-11	ELECT	220uF 20% 50V
C562	1-162-282-31	CERAMIC	100PF 10% 50V
C563	1-162-282-31	CERAMIC	100PF 10% 50V
C565	1-124-911-11	ELECT	220uF 20% 50V
C601	1-124-443-00	ELECT	100uF 20% 10V
C602	1-164-159-11	CERAMIC	0.1uF 50V
C603	1-161-494-00	CERAMIC	0.022uF 25V
C604	1-164-159-11	CERAMIC	0.1uF 50V
C605	1-124-902-00	ELECT	0.47uF 20% 50V
C606-608			
	1-124-480-11	ELECT	470uF 20% 25V
C609	1-124-902-00	ELECT	0.47uF 20% 50V
C610	1-124-472-11	ELECT	470uF 20% 10V
C611	1-162-290-31	CERAMIC	470PF 10% 50V
C612	1-124-472-11	ELECT	470uF 20% 10V
C613	1-162-290-31	CERAMIC	470PF 10% 50V
C614	1-164-159-11	CERAMIC	0.1uF 50V
C615	1-164-159-11	CERAMIC	0.1uF 50V
C617	1-164-159-11	CERAMIC	0.1uF 50V
C618	1-162-288-31	CERAMIC	330PF 10% 50V
C619	1-164-159-11	CERAMIC	0.1uF 50V
C620	1-124-907-11	ELECT	10uF 20% 50V
C621	1-124-907-11	ELECT	10uF 20% 50V
C622	1-124-477-11	ELECT	47uF 20% 25V
C623	1-124-477-11	ELECT	47uF 20% 25V
C630	1-126-963-11	ELECT	4.7uF 20% 50V
C631	1-124-903-11	ELECT	1uF 20% 50V
C636	1-124-916-11	ELECT	22uF 20% 63V
C641	1-126-963-11	ELECT	4.7uF 20% 50V
C642	1-124-902-00	ELECT	0.47uF 20% 50V
C645	1-124-907-11	ELECT	10uF 20% 50V
C646	1-124-925-11	ELECT	2.2uF 20% 100V
C649	1-124-907-11	ELECT	10uF 20% 50V
C650	1-124-916-11	ELECT	22uF 20% 63V
C651	1-124-443-00	ELECT	100uF 20% 10V
C800	1-162-282-31	CERAMIC	100PF 10% 50V

Ref. No.	Part No.	Description	Remark
C1000	1-124-910-11	ELECT	47uF 20% 50V
C6035	1-162-294-31	CERAMIC	0.001uF 10% 50V
		< CONNECTOR >	
CN601	1-750-585-11	CONNECTOR, FFC/FPC 7P	
* CN602	1-691-916-11	CONNECTOR, BOARD TO BOARD	
CN603	1-750-585-11	CONNECTOR, FFC/FPC 7P	
* CN604	1-691-916-11	CONNECTOR, BOARD TO BOARD	
* CN605	1-691-916-11	CONNECTOR, BOARD TO BOARD	
CN608	1-770-165-11	CONNECTOR, FFC/FPC 13P	
CN609	1-770-158-21	HOUSING, CONNECTOR 7P (SYSTEM CONTROL)	
* CN610	1-565-561-11	PIN, CONNECTOR 3P (AU BUS)	
		< DIODE >	
	D508-513		
	8-719-200-02	DIODE	10E2
D515	8-719-200-02	DIODE	10E2
D516	8-719-200-02	DIODE	10E2
D517	8-719-934-22	DIODE	HZS30-2L
D518	8-719-011-38	DIODE	UZ-2.4BSB-TA
D519	8-719-200-02	DIODE	10E2
D520	8-719-987-63	DIODE	1N4148M
D521	8-719-987-63	DIODE	1N4148M
D522	8-719-200-02	DIODE	10E2
D523	8-719-987-63	DIODE	1N4148M
D524	8-719-987-63	DIODE	1N4148M
D525	8-719-200-02	DIODE	10E2
D526	8-719-200-02	DIODE	10E2
D527	8-719-987-63	DIODE	1N4148M
D528	8-719-987-63	DIODE	1N4148M
	D601-604		
	8-719-987-63	DIODE	1N4148M
D605	8-719-200-02	DIODE	10E2
D606	8-719-200-02	DIODE	10E2
D607-609			
	8-719-987-63	DIODE	1N4148M
D610	8-719-200-02	DIODE	10E2
D611	8-719-987-63	DIODE	1N4148M
D620	8-719-011-40	DIODE	UZ-2.7BSA-TA
		< IC >	
IC101	8-752-058-57	IC	CXA1599Q
IC102	8-759-939-73	IC	BA3308
IC103	8-752-059-55	IC	CXA1331S
IC104	8-759-337-73	IC	M38123M4-118FP
IC502	8-759-231-53	IC	TA7805S
IC503	8-759-604-86	IC	M5F7807L
IC504	8-759-604-90	IC	M5F7907L
IC505	8-759-604-86	IC	M5F7807L

# MAIN

Ref. No.	Part No.	Description	Remark	Ref. No.	Part No.	Description	Remark
IC506	8-759-604-90	IC M5F7907L		R121	1-247-807-31	CARBON 100 5%	1/4W
IC602	8-759-510-54	IC PST572D		R122	1-249-422-11	CARBON 2.7K 5%	1/4W
IC603	8-759-266-35	IC TA8242AK		R206	1-247-832-11	CARBON 1.1K 5%	1/4W
IC6004	8-759-000-48	IC MC14052BCP		R207	1-247-864-11	CARBON 24K 5%	1/4W
< COIL >				R208	1-249-414-11	CARBON 560 5%	1/4W
L101	1-410-470-11	INDUCTOR 10uH		R209	1-249-429-11	CARBON 10K 5%	1/4W
L102	1-410-470-11	INDUCTOR 10uH		R210	1-249-427-11	CARBON 6.8K 5%	1/4W
L601	1-410-482-31	INDUCTOR 100uH		R211	1-249-427-11	CARBON 6.8K 5%	1/4W
L6002	1-410-470-11	INDUCTOR 10uH		R212	1-247-832-11	CARBON 1.1K 5%	1/4W
< JACK >				R213	1-249-429-11	CARBON 10K 5%	1/4W
PJ101	1-695-188-31	JACK, PIN 4P (TAPE 1 IN/OUT) (EX7)		R214	1-249-421-11	CARBON 2.2K 5%	1/4W
PJ102	1-695-188-31	JACK, PIN 4P (TAPE 1 IN/OUT) (EX10)		R215	1-247-887-00	CARBON 220K 5%	1/4W
< TRANSISTOR >				R216	1-249-437-11	CARBON 47K 5%	1/4W
Q101	8-729-119-78	TRANSISTOR 2SC2785-HFE		R217	1-249-415-11	CARBON 680 5%	1/4W
Q122	8-729-900-89	TRANSISTOR DTC144ES		R218	1-249-439-11	CARBON 68K 5%	1/4W
Q201	8-729-119-78	TRANSISTOR 2SC2785-HFE		R219	1-249-415-11	CARBON 680 5%	1/4W
Q222	8-729-900-89	TRANSISTOR DTC144ES		R220	1-247-807-31	CARBON 100 5%	1/4W
Q505	8-729-118-01	TRANSISTOR 2SB1116-K		R221	1-247-807-31	CARBON 100 5%	1/4W
Q603	8-729-801-93	TRANSISTOR 2SD1387		R222	1-249-422-11	CARBON 2.7K 5%	1/4W
Q604	8-729-801-93	TRANSISTOR 2SD1387		R504	1-247-807-31	CARBON 100 5%	1/4W
Q605	8-729-900-80	TRANSISTOR DTC114ES		R505	1-249-429-11	CARBON 10K 5%	1/4W
Q607-609	8-729-900-89	TRANSISTOR DTC144ES		R506	1-249-393-11	CARBON 10 5%	1/4W
Q611	8-729-620-05	TRANSISTOR 2SC2603-EF		R507	1-249-429-11	CARBON 10K 5%	1/4W
Q612	8-729-119-76	TRANSISTOR 2SA1175-HFE		R522	1-249-441-11	CARBON 100K 5%	1/4W
Q613	8-729-900-65	TRANSISTOR DTA144ES		R523	1-247-807-31	CARBON 100 5%	1/4W
Q614	8-729-900-89	TRANSISTOR DTC144ES		R528	1-249-413-11	CARBON 470 5%	1/4W
Q627	8-729-900-89	TRANSISTOR DTC144ES		R529	1-249-413-11	CARBON 470 5%	1/4W
Q630	8-729-900-61	TRANSISTOR DTA114ES		R530-535	1-260-093-11	CARBON 330 5%	1/2W
< RESISTOR >				R601	1-247-807-31	CARBON 100 5%	1/4W
R106	1-247-832-11	CARBON 1.1K 5%	1/4W	R602	1-247-807-31	CARBON 100 5%	1/4W
R107	1-247-864-11	CARBON 24K 5%	1/4W	R606	1-249-435-11	CARBON 33K 5%	1/4W
R108	1-249-414-11	CARBON 560 5%	1/4W	R607	1-247-807-31	CARBON 100 5%	1/4W
R109	1-249-429-11	CARBON 10K 5%	1/4W	R615	1-247-807-31	CARBON 100 5%	1/4W
R110	1-249-427-11	CARBON 6.8K 5%	1/4W	R616	1-247-863-91	CARBON 22K 5%	1/4W
R111	1-249-427-11	CARBON 6.8K 5%	1/4W	R620	1-249-441-11	CARBON 100K 5%	1/4W
R112	1-247-832-11	CARBON 1.1K 5%	1/4W	R621	1-249-417-11	CARBON 1K 5%	1/4W
R113	1-249-429-11	CARBON 10K 5%	1/4W	R622	1-249-421-11	CARBON 2.2K 5%	1/4W
R114	1-249-421-11	CARBON 2.2K 5%	1/4W	R623	1-249-421-11	CARBON 2.2K 5%	1/4W
R115	1-247-887-00	CARBON 220K 5%	1/4W	R624	1-249-434-11	CARBON 27K 5%	1/4W
R116	1-249-437-11	CARBON 47K 5%	1/4W	R625-627	1-249-421-11	CARBON 2.2K 5%	1/4W
R117	1-249-415-11	CARBON 680 5%	1/4W	R628	1-249-434-11	CARBON 27K 5%	1/4W
R118	1-249-439-11	CARBON 68K 5%	1/4W	R629	1-249-421-11	CARBON 2.2K 5%	1/4W
R119	1-249-415-11	CARBON 680 5%	1/4W	R630	1-249-429-11	CARBON 10K 5%	1/4W
R120	1-247-807-31	CARBON 100 5%	1/4W	R631	1-249-421-11	CARBON 2.2K 5%	1/4W
				R632	1-249-429-11	CARBON 10K 5%	1/4W
				R633	1-247-807-31	CARBON 100 5%	1/4W
				R634	1-247-807-31	CARBON 100 5%	1/4W

<b>MAIN</b>	<b>PANEL</b>
-------------	--------------

Ref. No.	Part No.	Description	Remark
R637	1-249-401-11	CARBON	47 5% 1/4W
R638	1-249-437-11	CARBON	47K 5% 1/4W
R639	1-249-429-11	CARBON	10K 5% 1/4W
R640	1-249-429-11	CARBON	10K 5% 1/4W
R641	1-249-417-11	CARBON	1K 5% 1/4W
R642	1-249-424-11	CARBON	3.9K 5% 1/4W
R643	1-247-807-31	CARBON	100 5% 1/4W
R644	1-247-807-31	CARBON	100 5% 1/4W
R645	1-249-425-11	CARBON	4.7K 5% 1/4W
R646	1-249-434-11	CARBON	27K 5% 1/4W
R647	1-249-430-11	CARBON	12K 5% 1/4W
R648-650			
	1-249-437-11	CARBON	47K 5% 1/4W
R656	1-249-393-11	CARBON	10 5% 1/4W
R660	1-249-417-11	CARBON	1K 5% 1/4W
R661	1-249-434-11	CARBON	27K 5% 1/4W
R670	1-247-863-91	CARBON	22K 5% 1/4W
R673	1-249-429-11	CARBON	10K 5% 1/4W
R674	1-247-860-11	CARBON	16K 5% 1/4W
R675	1-249-429-11	CARBON	10K 5% 1/4W
R676	1-249-434-11	CARBON	27K 5% 1/4W
R677-679			
	1-247-807-31	CARBON	100 5% 1/4W
R681-683			
	1-249-429-11	CARBON	10K 5% 1/4W
R684	1-249-413-11	CARBON	470 5% 1/4W
R685	1-249-429-11	CARBON	10K 5% 1/4W
R686	1-249-429-11	CARBON	10K 5% 1/4W
R687	1-249-417-11	CARBON	1K 5% 1/4W
R689	1-247-872-11	CARBON	51K 5% 1/4W
R690	1-249-429-11	CARBON	10K 5% 1/4W
R691	1-249-425-11	CARBON	4.7K 5% 1/4W
R693	1-247-863-91	CARBON	22K 5% 1/4W
R694	1-247-863-91	CARBON	22K 5% 1/4W
R695	1-249-421-11	CARBON	2.2K 5% 1/4W
R696	1-249-421-11	CARBON	2.2K 5% 1/4W
R700	1-247-903-00	CARBON	1M 5% 1/4W
R701	1-249-429-11	CARBON	10K 5% 1/4W
R702	1-249-437-11	CARBON	47K 5% 1/4W
R801	1-249-417-11	CARBON	1K 5% 1/4W
R807	1-247-863-91	CARBON	22K 5% 1/4W
R818	1-249-435-11	CARBON	33K 5% 1/4W
R819	1-249-393-11	CARBON	10 5% 1/4W
R850-853			
	1-247-863-91	CARBON	22K 5% 1/4W
R854	1-249-425-11	CARBON	4.7K 5% 1/4W
R855-859			
	1-247-807-31	CARBON	100 5% 1/4W
R6070	1-249-421-11	CARBON	2.2K 5% 1/4W
R6071	1-249-421-11	CARBON	2.2K 5% 1/4W

Ref. No.	Part No.	Description	Remark
< VARIABLE RESISTOR >			
RV101	1-238-600-11	RES, ADJ, CARBON 10K (RECORD LEVEL)	
RV201	1-238-600-11	RES, ADJ, CARBON 10K (RECORD LEVEL)	
< VIBRATOR >			
X601	1-577-358-21	VIBRATOR, CERAMIC (4MHz)	
*****			
*	A-2007-304-A	PANEL BOARD, COMPLETE (EX10)	
*	A-2007-306-A	PANEL BOARD, COMPLETE (EX7)	*****
*	3-919-591-01	HOLDER (FL TUBE)	
*	4-932-810-11	CUSHION (FL)	
< CAPACITOR >			
C301	1-164-159-11	CERAMIC	0.1uF 50V
C302	1-110-582-21	ELECT	3.3uF 20% 50V
C303	1-110-585-21	ELECT	22uF 20% 63V
C304	1-164-159-11	CERAMIC	0.1uF 50V
C305	1-162-288-31	CERAMIC	330PF 10% 50V
C307-309			
	1-162-288-31	CERAMIC	330PF 10% 50V
< CONNECTOR >			
CN900	1-770-063-11	CONNECTOR (FFC) 13P	
< INDICATOR TUBE >			
FL301	1-517-370-11	INDICATOR TUBE, FLUORESCENT	
< IC >			
IC301	8-759-342-15	IC M38122M2-102FP	
< RESISTOR >			
R301-305			
	1-247-807-31	CARBON	100 5% 1/4W
R306-308			
	1-249-429-11	CARBON	10K 5% 1/4W
R326-329			
	1-249-429-11	CARBON	10K 5% 1/4W
R331	1-249-429-11	CARBON	10K 5% 1/4W
R332-337			
	1-249-441-11	CARBON	100K 5% 1/4W
R900	1-249-418-11	CARBON	1.2K 5% 1/4W
R901	1-249-420-11	CARBON	1.8K 5% 1/4W
R902	1-249-422-11	CARBON	2.7K 5% 1/4W
R903	1-249-424-11	CARBON	3.9K 5% 1/4W
R904	1-249-427-11	CARBON	6.8K 5% 1/4W



**PANEL**

Ref. No.	Part No.	Description	Remark
R905	1-249-418-11	CARBON	1. 2K 5% 1/4W
R906	1-249-420-11	CARBON	1. 8K 5% 1/4W
R907	1-249-422-11	CARBON	2. 7K 5% 1/4W
R908	1-249-424-11	CARBON	3. 9K 5% 1/4W
R909	1-249-427-11	CARBON	6. 8K 5% 1/4W
R910	1-249-431-11	CARBON	15K 5% 1/4W
R911	1-249-437-11	CARBON	47K 5% 1/4W
R912	1-249-426-11	CARBON	5. 6K 5% 1/4W
R913	1-249-424-11	CARBON	3. 9K 5% 1/4W
R914	1-249-427-11	CARBON	6. 8K 5% 1/4W
R915	1-249-431-11	CARBON	15K 5% 1/4W
R916	1-249-425-11	CARBON	4. 7K 5% 1/4W

< SWITCH >

S301	1-554-303-21	SWITCH, TACTILE	( < ) (DECK B)
S302	1-554-303-21	SWITCH, TACTILE	( > ) (DECK B)
S303	1-554-303-21	SWITCH, TACTILE	( □ ) (DECK B)
S304	1-554-303-21	SWITCH, TACTILE	(PAUSE)
S305	1-554-303-21	SWITCH, TACTILE	( ◀ ) (DECK A)
S306	1-554-303-21	SWITCH, TACTILE	( ▶ ) (DECK A)
S307	1-554-303-21	SWITCH, TACTILE	( < ) (DECK A)
S308	1-554-303-21	SWITCH, TACTILE	( > ) (DECK A)
S309	1-572-184-11	SWITCH, KEYBOARD	( □ ) (DECK A)
S310	1-554-303-21	SWITCH, TACTILE	( ◀ ) (DECK B)
S311	1-554-303-21	SWITCH, TACTILE	( ▶ ) (DECK B)
S312	1-554-303-21	SWITCH, TACTILE	(REC MUTE)
S313	1-554-303-21	SWITCH, TACTILE	(DUBBING MODE)
S314	1-554-303-21	SWITCH, TACTILE	(CD SYNCHRO)
S315	1-554-303-21	SWITCH, TACTILE	(COUNTER A/B)
S316	1-554-303-21	SWITCH, TACTILE	(RESET)
S317	1-554-303-21	SWITCH, TACTILE	(REC)
S900	1-762-205-11	SWITCH, SLIDE	(DIRECTION MODE)
S901	1-762-205-11	SWITCH, SLIDE	(DOLBY NR)

< VIBRATOR >

X301 1-760-534-11 VIBRATOR, CERAMIC (4MHz)

\*\*\*\*\*

MISCELLANEOUS

\*\*\*\*\*

58	1-769-391-11	WIRE (FLAT TYPE)	(13 CORE)
69	1-765-384-11	WIRE (FLAT TYPE)	(7 CORE)
271	1-638-983-11	MOTOR FLEXIBLE BOARD	
HP1	A-2003-757-A	BASE ASSY, HEAD (PB)	(DECK A)
HRPE1	A-2003-930-A	BASE ASSY, HEAD (PB/REC/ERASE)	(DECK B)
M101	X-3365-377-2	MOTOR ASSY (CAPSTAN)	
M202	X-3365-501-2	MOTOR ASSY (REEL)	

\*\*\*\*\*

Ref. No.	Part No.	Description	Remark
		*****	
		<b>HARDWARE LIST</b>	
		*****	
#1	7-685-646-79	SCREW +BVTP 3×8 TYPE2 N-S	
#2	7-621-770-67	SCREW +PTT 2.6×6 (S)	
#3	7-627-556-08	SCREW +P 2.6×2.8	
#4	7-621-775-00	SCREW +B 2.6×3	

# TC-EX7/EX10

**SONY**

## SERVICE MANUAL

*AEP Model*

*UK Model*

*TC-EX7/EX10*

*E Model*

*Australian Model*

*TC-EX10*

## CORRECTION-1

Correct your service manual as shown below.

\_\_\_\_ (Under line) : indicates corrected portion.

Page	INCORRECT			CORRECT		
	<u>Ref. No.</u>	<u>Part No.</u>	<u>Description</u>	<u>Ref. No.</u>	<u>Part No.</u>	<u>Description</u>
26, 34	M202	X-3365-501-2	MOTOR ASSY (REEL)	<u>M102</u>	X- <del>3363</del> -501-2	MOTOR ASSY (REEL)

(RPC-96023)