

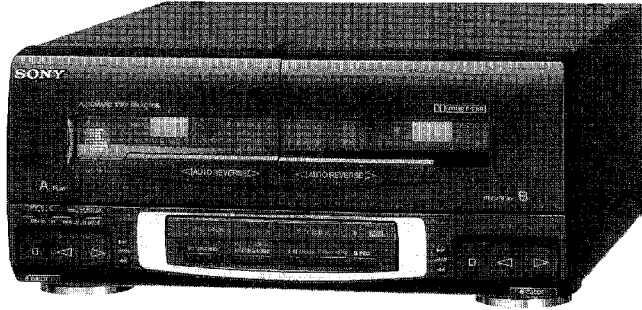

TC-EX5

SERVICE MANUAL

*AEP Model
UK Model
E Model
Australian Model
Tourist Model*



TC-EX5 is cassette deck section in MHC-EX5.

Dolby noise reduction manufactured under license from Dolby Laboratories Licensing Corporation. "DOLBY" and the double-D symbol  are trademarks of Dolby Laboratories Licensing Corporation.

Model Name Using Similar Mechanism		NEW
Tape Transport Mechanism Type	DECK A	TCM-190RA12CL
	DECK B	TCM-190RB52C

SPECIFICATIONS

Recording system
4-track 2-channel stereo

Frequency response
(DOLBY NR OFF)
40 - 13,000 Hz (± 3 dB),
using Sony TYPE I cassette
40 - 14,000 Hz (± 3 dB),
using Sony TYPE II cassette
40 - 15,000 Hz (± 3 dB),
using Sony TYPE IV cassette

Wow and flutter
0.1% WRMS \pm 0.3% (DIN)

Dimensions
Approx. 280 x 125 x 285 mm (w/h/d)
(11 1/8 x 5 x 11 1/4 inches)

Mass Approx. 2.9 kg (6 lb 7 oz)



Design and specifications are subject to change without notice.

STEREO CASSETTE DECK
SONY[®]

TABLE OF CONTENTS

Section	Title	Page
1. GENERAL	2
2. ADJUSTMENTS		
2-1. Mechanical Adjustments	3
2-2. Electrical Adjustments	3
3. EXPLANATION OF IC TERMINALS	7
4. DIAGRAMS		
4-1. Block Diagram	9
4-2. Printed Wiring Boards	13
4-3. Schematic Diagram	17
5. EXPLODED VIEWS		
5-1. Chassis Section	23
5-2. Front Panel Section	24
5-3. Mechanism Section-1	25
5-4. Mechanism Section-2	26
6. ELECTRICAL PARTS LIST	27

SAFETY-RELATED COMPONENT WARNING!!

COMPONENTS IDENTIFIED BY MARK  OR DOTTED LINE WITH MARK  ON THE SCHEMATIC DIAGRAMS AND IN THE PARTS LIST ARE CRITICAL TO SAFE OPERATION. REPLACE THESE COMPONENTS WITH SONY PARTS WHOSE PART NUMBERS APPEAR AS SHOWN IN THIS MANUAL OR IN SUPPLEMENTS PUBLISHED BY SONY.

SERVICING NOTE

• POWER SUPPLIED WHILE SERVICING

This unit does not work independently because of not having the power supply.

It must be unite together with the other units when repaired.

SECTION 1 GENERAL

LOCATION OF CONTROLS

This section is extracted from instruction manual.

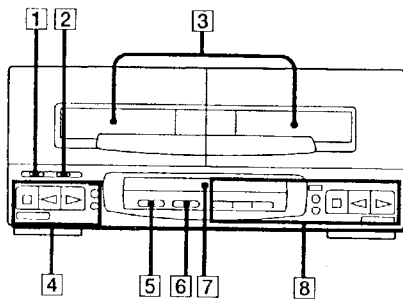

- | | |
|--|--|
| <p>1 DOLBY NR selector (15)</p> <p>2 DIRECTION MODE selector (14)</p> <p>3 Cassette compartments (14)</p> <p>4 Tape operating buttons (for deck A)</p> <p>▷ (front side play) (14)</p> <p>◁ (reverse side play) (14)</p> <p>□ (stop) (14)</p> <p>▶▶ (fast rightward and AMS**) (14)</p> <p>◀◀ (fast leftward and AMS**) (14)</p> <p>▲ EJECT button (14)</p> <p>5 CD SYNCHRO button* (15)</p> <p>6 DUBBING MODE button* (19)</p> <p>7 Display window</p> | <p>8 Tape operating buttons (for deck B)</p> <p>▷ (front side play) (14)</p> <p>◁ (reverse side play) (14)</p> <p>□ (stop) (14)</p> <p>▶▶ (fast rightward and AMS**) (14)</p> <p>◀◀ (fast leftward and AMS**) (14)</p> <p>⏸ PAUSE (14)</p> <p>○ REC MUTE button (16)</p> <p>● REC (recording) (16)</p> <p>▲ EJECT button (14)</p> <p>**AMS: Automatic Music Sensor (14)</p> |
|--|--|

SECTION 2 ADJUSTMENTS

2-1. MECHANICAL ADJUSTMENTS

PRECAUTION

1. Clean the following parts with a denatured alcohol-moistened swab:

record/playback/erase head	pinch roller
rubber belts	capstan
idlers	

2. Demagnetize the record/playback head with a head demagnetizer. (Head demagnetizer do not approach for the erase head.)
3. Do not use a magnetized screwdriver for the adjustment.
4. After the adjustments, apply suitable locking compound to the parts adjusted.
5. The adjustments should be performed with the rated power supply voltage unless otherwise noted.

Torque Measurement

Torque	Torque meter	Meter reading
Forward	CQ-102C	30 to 60g • cm (0.42 to 0.83oz • inch)
Forward back tension	CQ-102C	1 to 5g • cm (0.014 to 0.069 oz • inch)
Reverse	CQ-102RC	30 to 60g • cm (0.42 to 0.83 oz • inch)
Reverse back tension	CQ-102RC	1 to 5g • cm (0.014 to 0.069 oz • inch)
FF/REW	CQ-201B	65 to 90g•cm (0.91 to 1.25 oz•inch)

2-2. ELECTRICAL ADJUSTMENTS

PRECAUTION

1. The adjustment should be performed in the publication. (Be sure to make playback adjustment at first.)
2. The adjustments and measurement should be performed for both L-CH and R-CH.

- Switch position

DOLBY NR switch : OFF
DIRECTION MODE switch : \Rightarrow

- Standard record position :

Deliver the standard input signal level to input jack as follows.

— Record Mode —

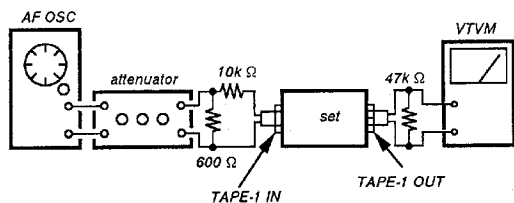

Standard Input Level

Input terminal	TAPE-1 (LINE IN)
source impedance	10k Ω
input signal level	0.5V (- 3.8dB)

Standard Output Level

Output terminal	TAPE-1 (LINE OUT)
load impedance	47k Ω
output signal level	0.5V (- 3.8dB)

Test Tape

Tape	Contents	Use
P-4-A100	10kHz, - 10dB	Azimuth Adjustment
P-4-L300	315Hz, 0dB	PB Level Adjustment
WS-48B	3kHz, 0dB	Tape Speed Adjustment

0dB=0.775V

Test Mode

1. If the power supply is TA-EX5. (When AU BUS is alive)
 - ① Short-circuit following portion (IC104 ⑤ pin) on the main board.
 - ② Turn the POWER on.
 - ③ Open the short-circuit to release test mode.

[TC MAIN BOARD]

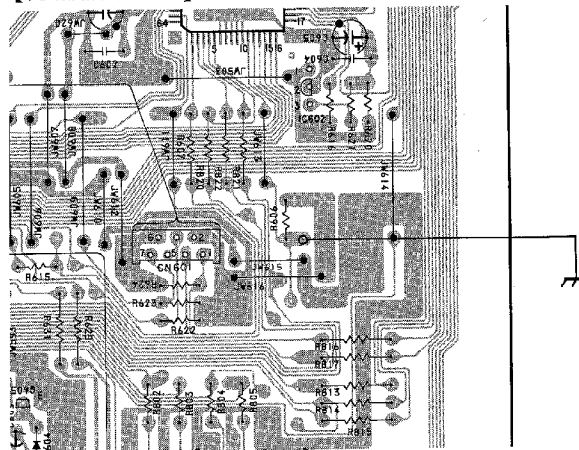

2. If the power supply is a jig.

After, turning on the power, press the STOP button of both DECK-A and DECK-B at the same time.

Record/Playback Head Azimuth Adjustment

DECK-A DECK-B

Procedure :

1. Forward playback Mode

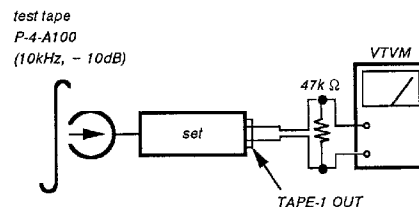

2. Turn the adjustment screw for the maximum output levels. If these levels do not match, turn the adjustment screw until both of output levels match together within 1dB.

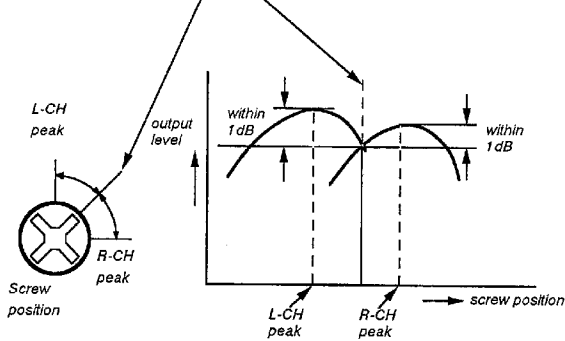

3. Playback Mode

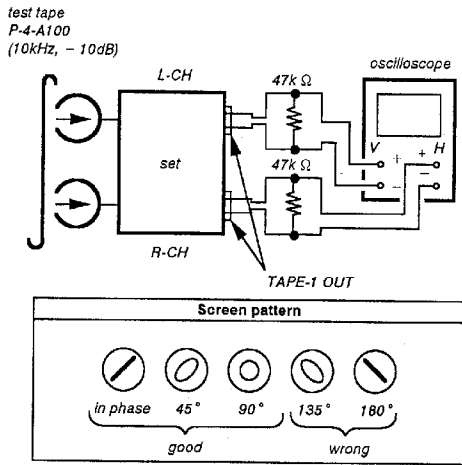

4. Change the reverse playback mode and repeat the steps 1 to 3.
5. After the adjustment, lock the adjustment screws with suitable locking compound.

Adjustment Location : - record/playback head -

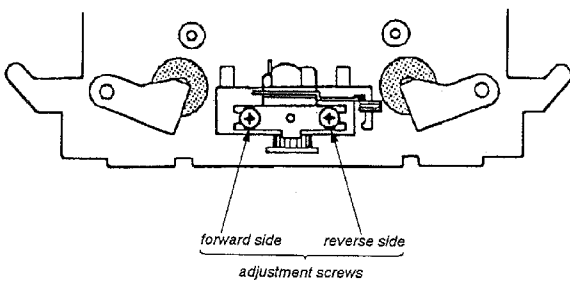

Tape Speed Adjustment

DECK-A DECK-B

Procedure :

- Forward Playback Mode -

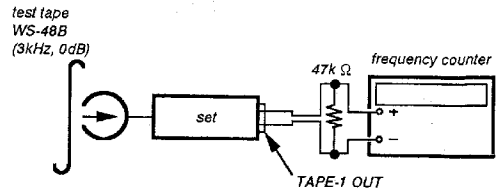

(high speed adjustment)

1. Connect ⑤ pin of IC104 to ground with lead wire.
2. Set to FWD playback mode.
3. Keep on pressing the DUBBING MODE button at HIGH position.
4. Adjust RV72 so that the frequency counter reading becomes $6,000 \pm 30\text{Hz}$.

(normal speed adjustment)

1. Set to FWD playback mode.
2. Set the DUBBING MODE button to NORMAL.
3. Adjust RV71 so that the frequency counter reading becomes $3,000 \pm 15\text{Hz}$.

Frequency difference between the beginning and the end of the tape should be within 3%.

Frequency difference between the deck A and deck B the beginning of the tape should be within 1.5%.

Adjustment Location : AUDIO board. (See page 6)

Playback Level Adjustment

DECK-A DECK-B

Procedure :

- Forward Playback Mode -

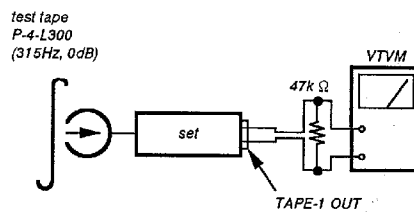

Adjust RV11(L-CH) and RV21(R-CH) so the VTVM reading becomes the adjustment limits below.

Adjustment Value :

TAPE-1 OUT level : $- 7.7 \pm 0.5\text{dB}$ (0.301 to 0.338V)

Level difference between channels : within 0.5dB

Confirm the TAPE-1 OUT level does not change in playback mode while changing the mode from playback to stop several times.

Adjustment Location : AUDIO board. (See page 6)

Record Bias Adjustment DECK-B

Procedure :

1. Record Mode

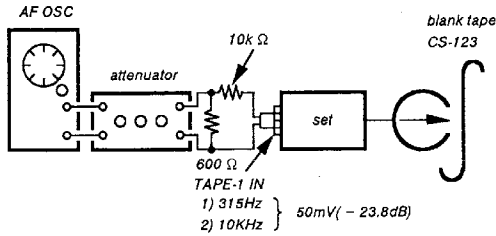

2. Playback Mode

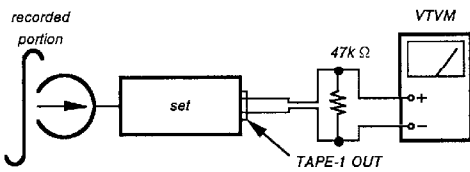

Confirm that the 10kHz playback output is $0 \pm 0.5\text{dB}$ relative to the 315Hz output. If necessary, adjust RV12 (L-CH), RV22 (R-CH) and repeat the steps given above.

Adjustment Location : AUDIO board. (See page 6)

Record Level Adjustment DECK-B

Procedure :

1. Record Mode

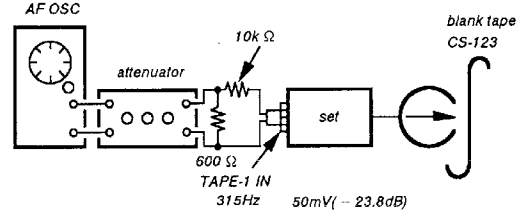

2. Playback Mode

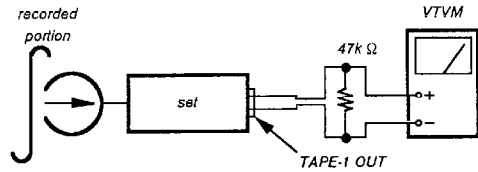

Confirm playback the tape recorded become adjustment level as follows.

If necessary, adjust RV101 (L-CH), RV201 (R-CH) and repeat the steps 1 and 2.

Adjustment Value :

TAPE-1 OUT level : $-23.8 \pm 0.5\text{dB}$ (47.2 to 53mV)

Adjustment Location : TC MAIN board. (See page 6)

— Adjustment Parts Location Diagrams —

[TC MAIN BOARD]

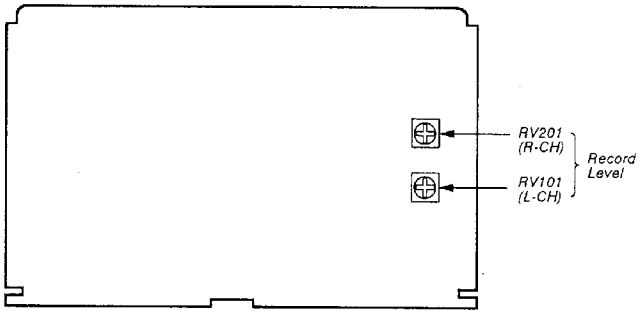

DECK A :
[AUDIO BOARD]

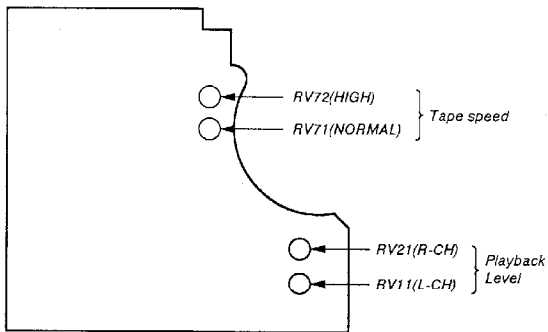

DECK B :
[AUDIO BOARD]

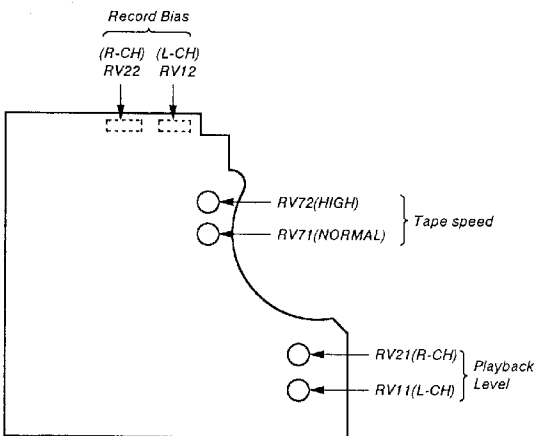

SECTION 3 EXPLANATION OF IC TERMINALS

IC104 M38123M4-118FP TC CONTROL (TC MAIN BOARD)

Pin No.	Pin name	I/O	Description																				
1	B HALF	I	B Half detection input. "L" : Presence "H" : Nothing																				
2	KEY3	I	Key input. (A/D converter analog input)																				
3	KEY2																						
4	KEY1																						
5	TEST	I	Electrical adjustment test mode setting. "L" : Test mode																				
6	DISP RST	O	GND.																				
7	DISP SYNC																						
8	DISP CLK																						
9	DISP OUT																						
10	DISP IN																						
11	B REEL2	O	Deck B reel motor control output.																				
12	B REEL3																						
13	B REEL1																						
<table border="1" style="margin-left: auto; margin-right: auto;"> <thead> <tr> <th></th> <th>FF</th> <th>TRIG</th> <th>STOP</th> <th>FWD</th> </tr> </thead> <tbody> <tr> <td>REEL 1</td> <td>H</td> <td>L</td> <td>L</td> <td>H</td> </tr> <tr> <td>REEL 2</td> <td>L</td> <td>H</td> <td>L</td> <td>L</td> </tr> <tr> <td>REEL 3</td> <td>H</td> <td>H</td> <td>L</td> <td>L</td> </tr> </tbody> </table>					FF	TRIG	STOP	FWD	REEL 1	H	L	L	H	REEL 2	L	H	L	L	REEL 3	H	H	L	L
	FF	TRIG	STOP	FWD																			
REEL 1	H	L	L	H																			
REEL 2	L	H	L	L																			
REEL 3	H	H	L	L																			
14	A REEL1	O	Deck A reel motor control output.																				
15	A REEL3																						
16	A REEL2																						
17	PWR IN	I	+5V power supply input.																				
18	AUB IN	I	Audio bus input.																				
19	NRST	I	Microcomputer reset input.																				
20	AUB OUT	O	Audio bus output.																				
21	XC OUT	O	Not used. (GND)																				
22	X IN	I	Oscillator connection pins. (4MHz)																				
23	X OUT	O																					
24	V _{SS}	-	GND.																				
25	VER	-	GND.																				
26	PWR OUT	O	Not used. (Open)																				
27	LINE MUTE	O	Line mute ON/OFF. "L" : ON																				
28	BIAS	O	Bias oscillation control output. "L" : ON																				
29	NC	-	GND.																				
30	DAT FUNC	O	DAT mute output.																				
31	CD FUNC	O	CD mute output.																				
32	PASS	O	PASS amplifier switch output to dolby.																				
33	EQ H/L	O	REC equalizer switching output. "L" : High speed "H" : Normal speed																				
34	REC MUTE	O	REC mute output.																				
35	PB SEL	O	Play mode deck A/B select output. "L" : DECK A "H" : DECK B																				
36	AMS G SEL	O	AMS/BS mode select output. "H" : AMS mode "L" : BS mode																				
37	1599 MUTE	O	Mute output to IC101 (CXA1599Q). "H" : ON "L" : OFF																				
38	NC	-	Not used. (GND)																				
39	NR RELAY	O	ALC control output.																				
40	CD SYNC	O	CD synchro dubbing LED output "H" : ON "L" : OFF																				

Pin No.	Pin name	I/O	Description
41	DUB H	O	High speed dubbing LED output. "H" : ON "L" : OFF
42	DUB N	O	Normal speed dubbing LED output. "H" : ON "L" : OFF
43	PAUSE	O	PAUSE LED output. "H" : ON "L" : OFF
44	REC	O	REC LED output. "H" : ON "L" : OFF
45	B ◀	O	Deck B REV LED output. "H" : ON "L" : OFF
46	B ▶	O	Deck B FWD LED output. "H" : ON "L" : OFF
47	A ◀	O	Deck A REV LED output. "H" : ON "L" : OFF
48	A ▶	O	Deck A FWD LED output. "H" : ON "L" : OFF
49	B STOP SW	I	Deck B stop detect input. "H" : STOP
50	A STOP SW	I	Deck A stop detect input. "H" : STOP
51	+7.5V DET	I	+7.5V power supply detect input.
52	RELAY	O	Control output to REC/PB select output. "H" : REC "L" : PLAY
53	REC/PB	O	Dolby IC (IC103) REC/PB select output. "H" : REC "L" : PLAY
54	CAP. MOT H/L	O	Capstan motor HIGH/LOW select output. "H" : HIGH "L" : LOW
55	B CAP. MOTOR	O	Deck B capstan motor control output. "H" : ON "L" : OFF
56	A CAP. MOTOR	O	Deck A capstan motor control output. "H" : ON "L" : OFF
57	V _{DD}	—	+5V power supply.
58	VEE	—	GND.
59	AV _{SS}	—	GND.
60	VREF	I	A/D converter reference power supply +5V.
61	A HALF	I	Deck A half detect input.
62	BS. REEL IN	I	Deck B reel table signal input.
63	AS. REEL IN	I	Deck A reel table signal input.
64	AMS IN	I	AMS input. "L" : No song "H" : Song

SECTION 4
DIAGRAMS

4-1. BLOCK DIAGRAM

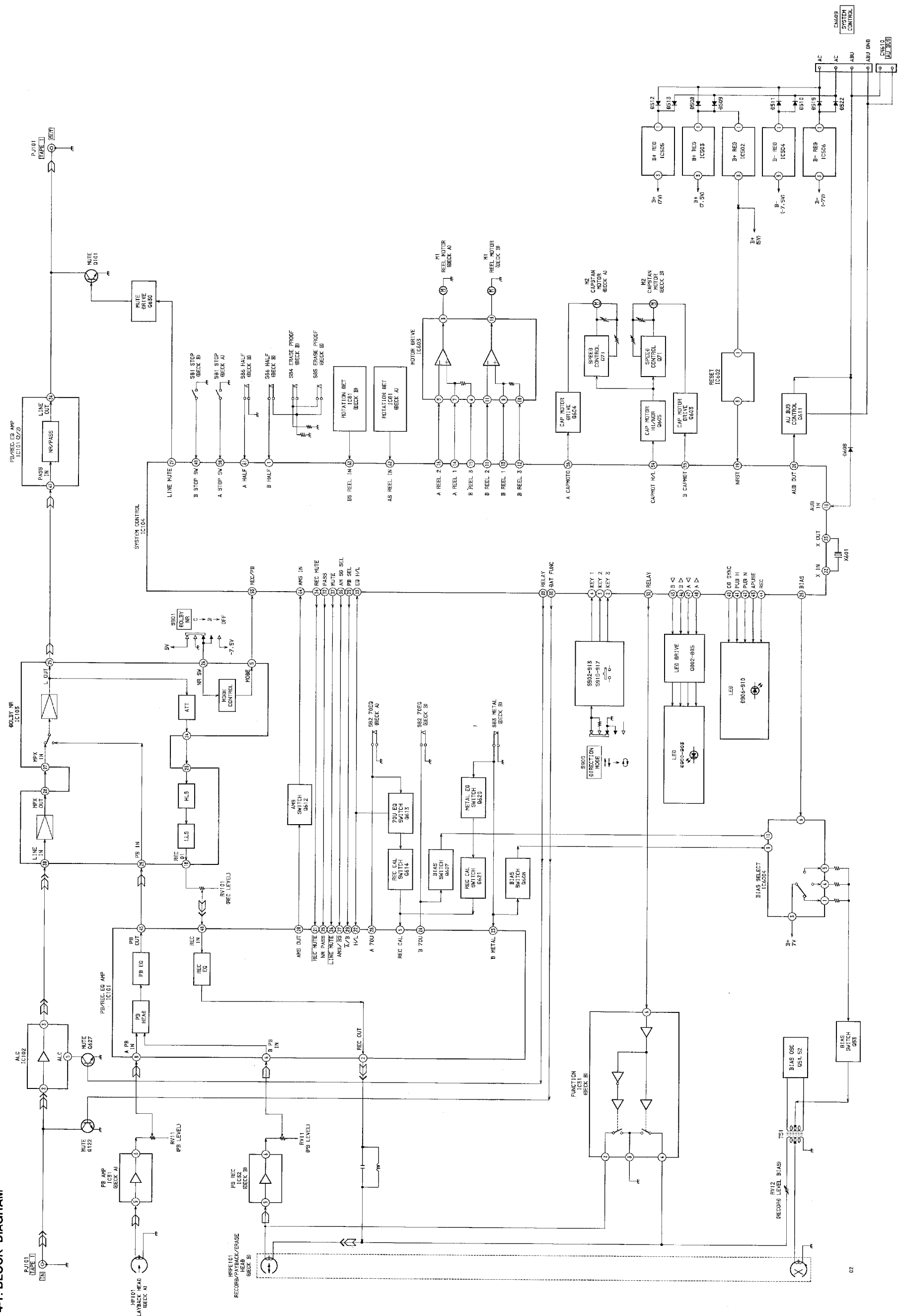

● CIRCUIT BOARD LOCATION

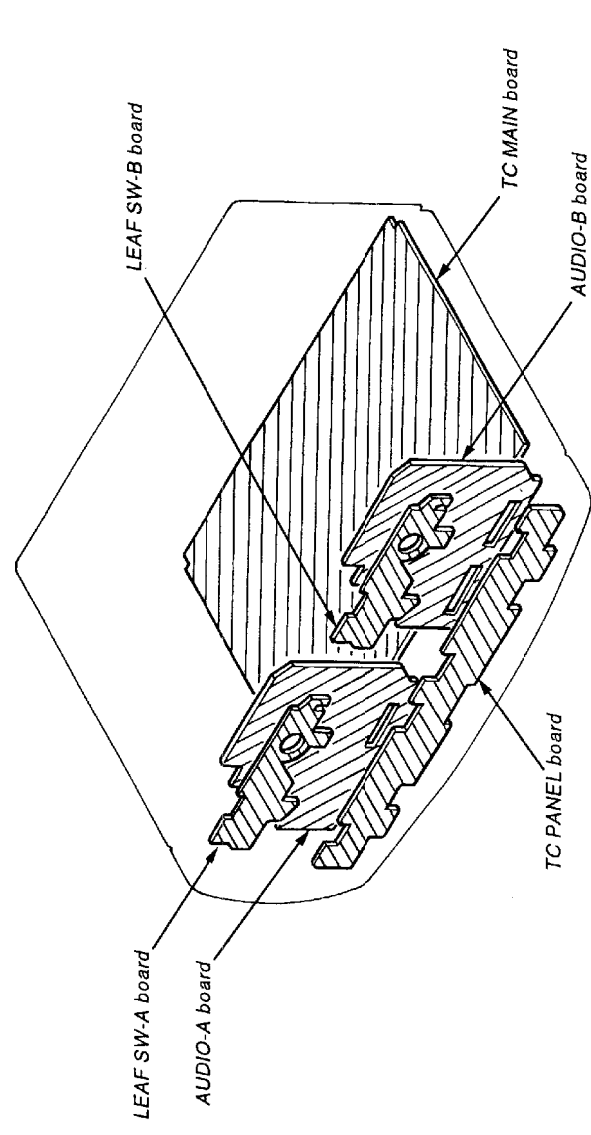

• Signal path.
 ◁ : PB (DECK A)
 ▷ : PB (DECK B)
 ◁ ▷ : REC (DECK B)

● SEMICONDUCTOR LEAD LAYOUTS

BA3308

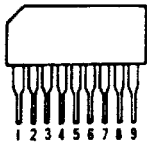

M38123M4-118FP

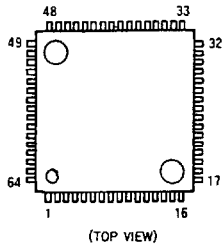

PST572D

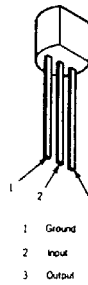

DTA114ES
DTA144ES
DTC114ES
DTC144ES



2SD1387
2SD1616A-K

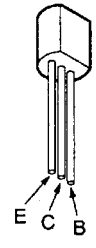

CXA1331S

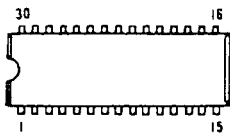

(Top view)

M5F7805S
M5F7807
M5F7907L
TA7805S

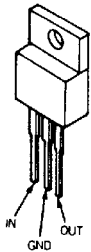

TA8242AK

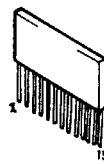

2SA1162-G

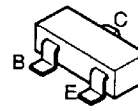

SEL5221S-TP15
SEL5421E-TH8F
SEL5921A-TH15

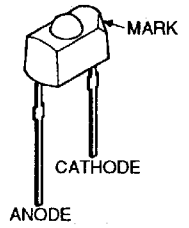

CXA1599Q

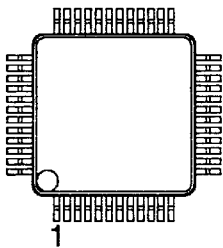

NJL5165K-B (H1)

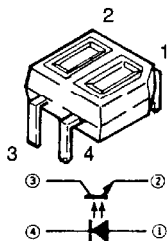

μPC1330AGR

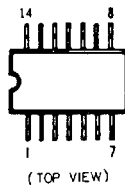

2SA1175-HFE
2SC3623A-K

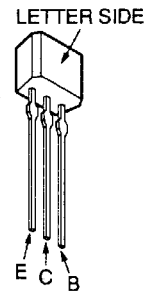

UZ-2.0BSB
1N4148M
10E2

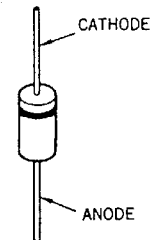

MC14052BCP

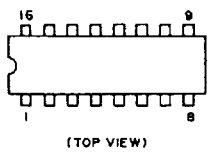

μPC4570G2

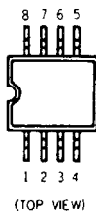

• SEMICONDUCTOR LOCATION

Ref. No.	Location	Ref. No.	Location
D508	B-26	IC102	C-20
D509	B-25	IC103	C-18
D510	B-25	IC104	E-25
D511	B-25	IC502	C-26
D512	B-24	IC503	D-25
D513	B-23	IC504	D-24
D519	B-23	IC505	C-22
D522	B-23	IC506	D-22
D523	C-25	IC602	E-26
D524	D-24	IC603	E-22
D525	B-22	IC6004	G-20
D526	B-22		
D601	D-26		
D602	E-26	Q51	C-5
D603	G-24	Q52	C-5
		Q53	C-4
D604	G-24	Q71 (A)	D-13
D605	E-22	Q71 (B)	D-6
D606	E-22		
D607	D-20	Q101	D-19
D608	D-27	Q122	B-21
		Q201	D-19
		Q222	B-20
D609	D-26	Q221	H-22
D610	F-22	Q603	H-22
D611	D-26		
D620	E-20	Q604	H-24
D900	J-21	Q605	G-24
		Q607	G-21
D901	J-20	Q608	G-21
D902	J-23	Q609	G-22
D903	J-22		
D906	J-20	Q611	C-26
D907	J-21	Q612	D-20
		Q613	E-20
D808	J-21	Q614	E-20
D909	J-23	Q620	E-20
D810	J-23		
		Q621	E-20
		Q627	B-20
		Q630	D-20
IC31 (A)	E-11	Q802	H-25
IC31 (B)	D-3	Q803	H-25
IC32	D-4		
IC81 (A)	I-13	Q804	H-26
IC81 (B)	I-5	Q805	H-26
IC101	E-19		

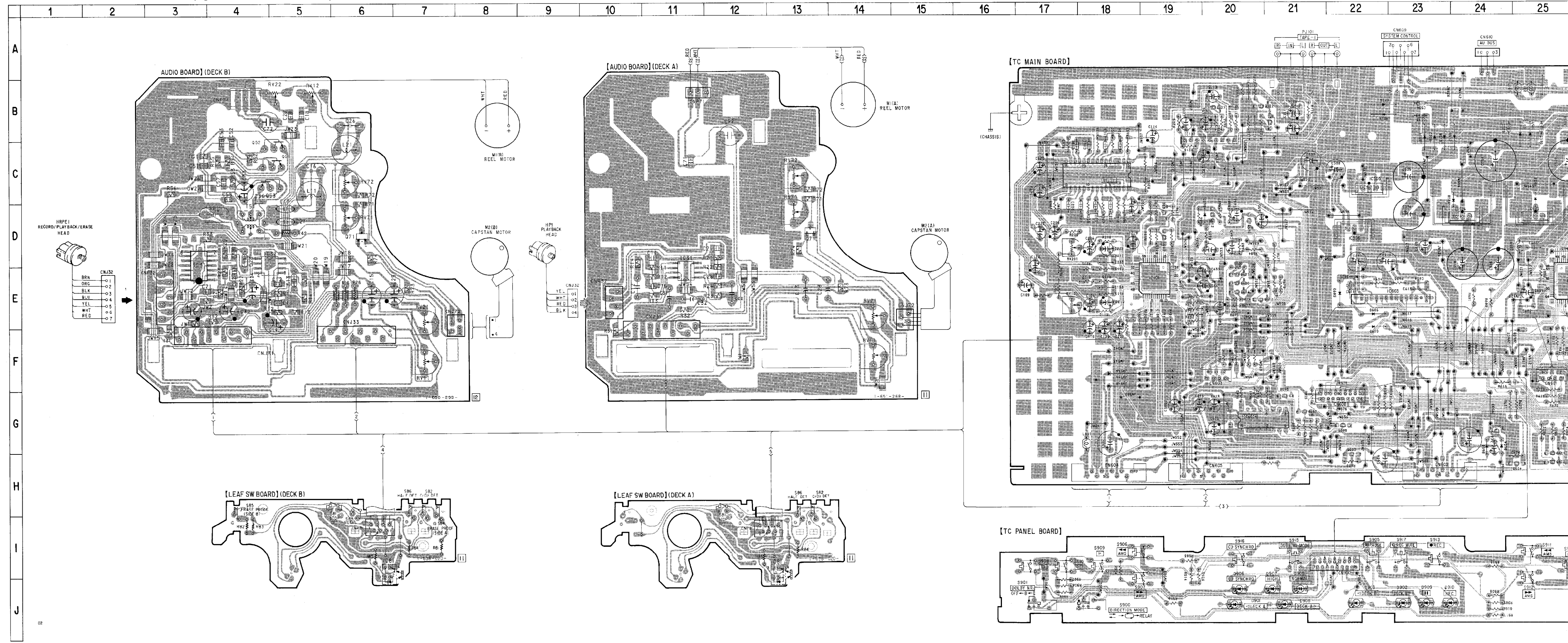

Note:
 ○ : parts extracted from the component side.
 ◐ : Pattern on the side which is seen.

4-3. SCHEMATIC DIAGRAM

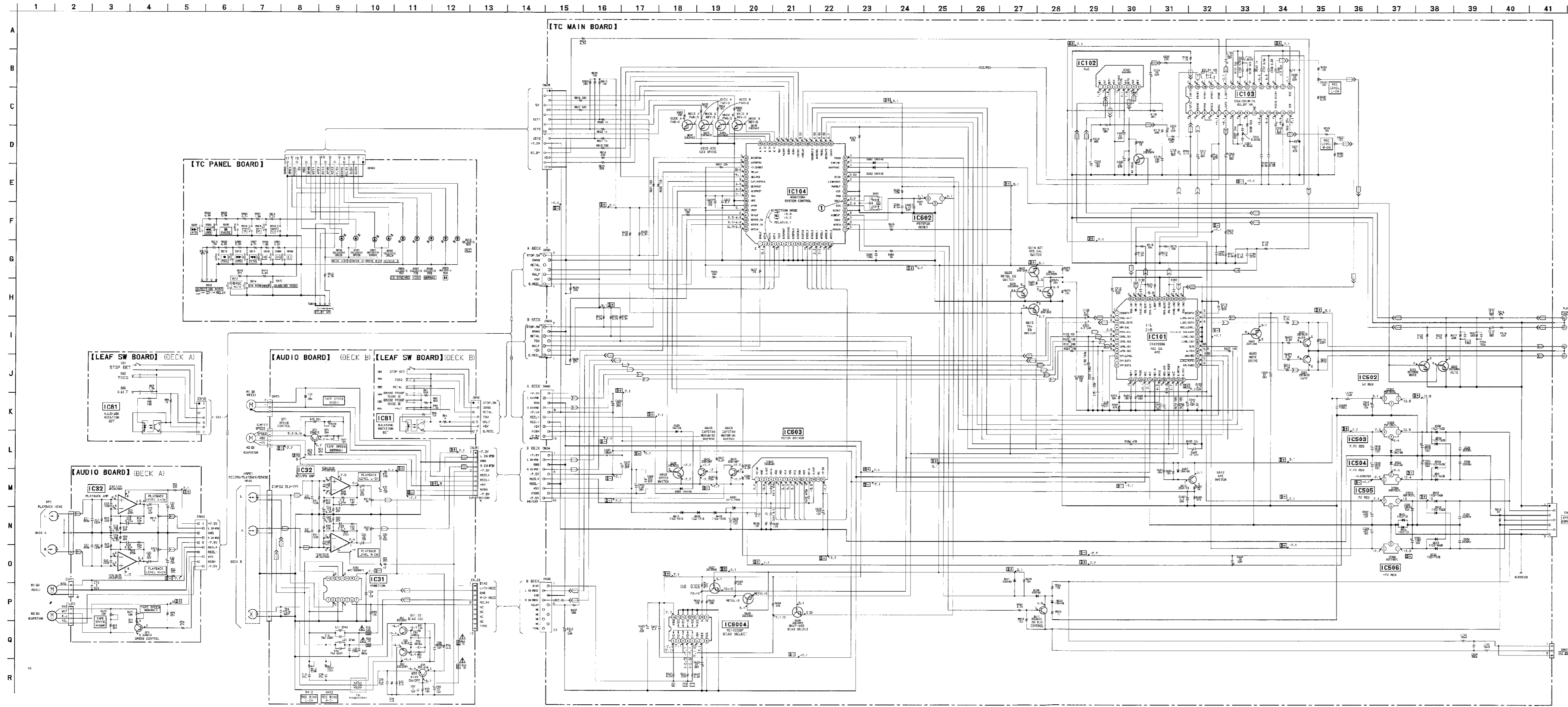

• IC BLOCK DIAGRAMS

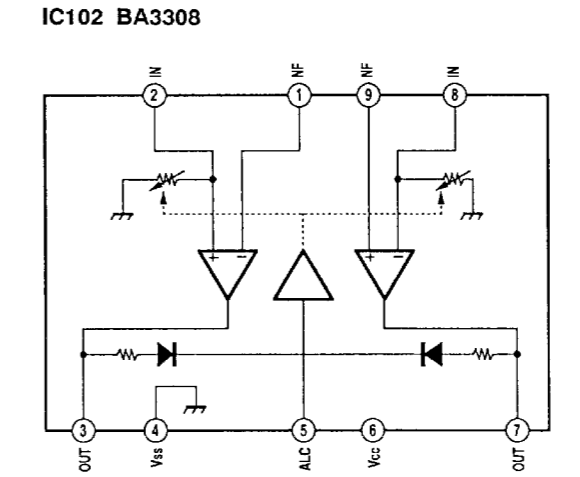

• WAVEFORM

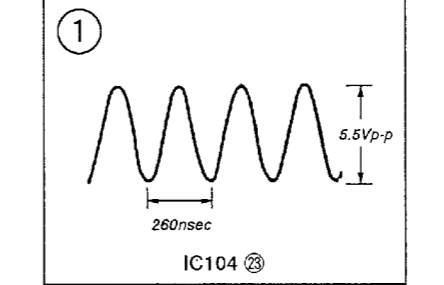

- Note :**
- All capacitors are in μF unless otherwise noted, pF: $\mu \mu F$ 50WV or less are not indicated except for electrolytics and tantalums.
 - All resistors are in Ω and $\frac{1}{4}W$ or less unless otherwise specified.
 - Δ : internal component.
 - \square : nonflammable resistor.
- Note :** The components identified by mark Δ or dotted line with mark Δ are critical for safety. Replace only with part number specified.

- **B+** : B+ Line
- **B-** : B- Line
- \square : adjustment for repair.
- Voltage and waveforms are dc with respect to ground under no-signal (detuned) conditions.
- no mark : STOP
- () : REC
- Voltages are taken with a VOM (Input impedance 10M Ω). Voltage variations may be noted due to normal production tolerances.
- Waveforms are taken with an oscilloscope. Voltage variations may be noted due to normal production tolerances.
- Circled numbers refer to waveforms.
- Signal path.
- \square : PB (DECK A)
- \square : PB (DECK B)
- \square : REC (DECK B)

SECTION 5 EXPLODED VIEWS

NOTE:

- -XX, -X mean standardized parts, so they may have some difference from the original one.
- The construction parts of an assembled part are indicated with a collation number in the remark column.

- Items marked " * " are not stocked since they are seldom required for routine service. Some delay should be anticipated when ordering these items.
- The mechanical parts with no reference number in the exploded views are not supplied.
- Hardware (# mark) list and accessories and packing materials are given in the last of this parts list.

5-1. CHASSIS SECTION

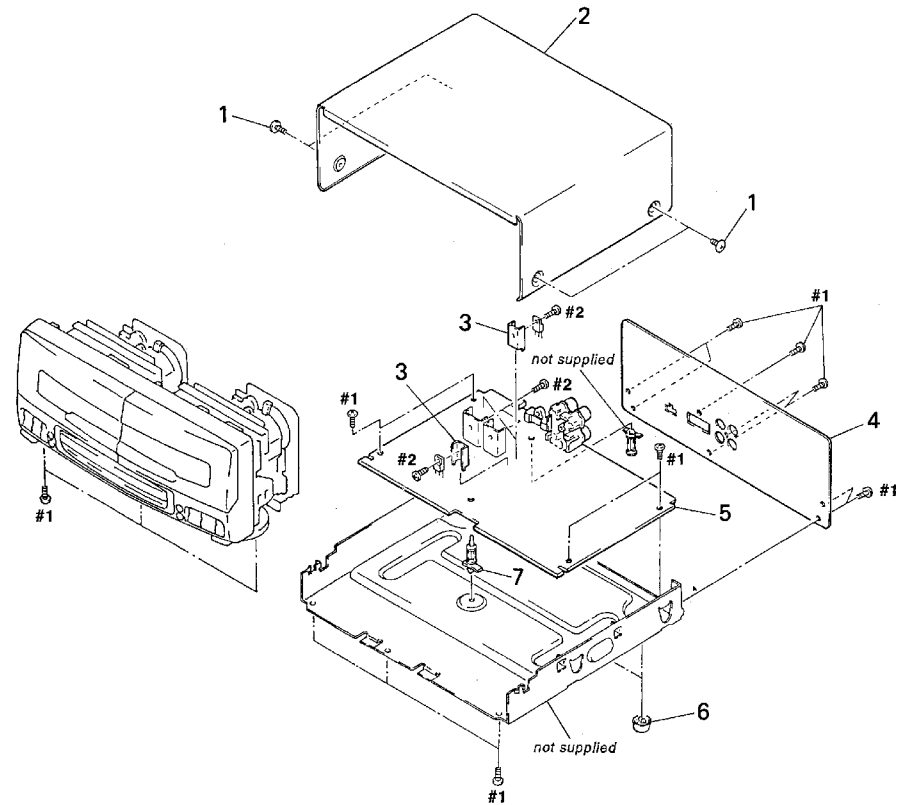

Ref.No.	Part No.	Description
1	3-363-099-21	SCREW (CASE 3 TP2)
2	3-919-558-01	CASE
* 3	3-309-144-21	HEAT SINK
* 4	3-919-578-01	PANEL, BACK

Ref.No.	Part No.	Description	Remark
* 5	A-2007-301-A	TC MAIN BOARD, COMPLETE	
6	4-965-822-01	FOOT	
* 7	3-349-025-41	HOLDER, PC BOARD	

5-2. FRONT PANEL SECTION

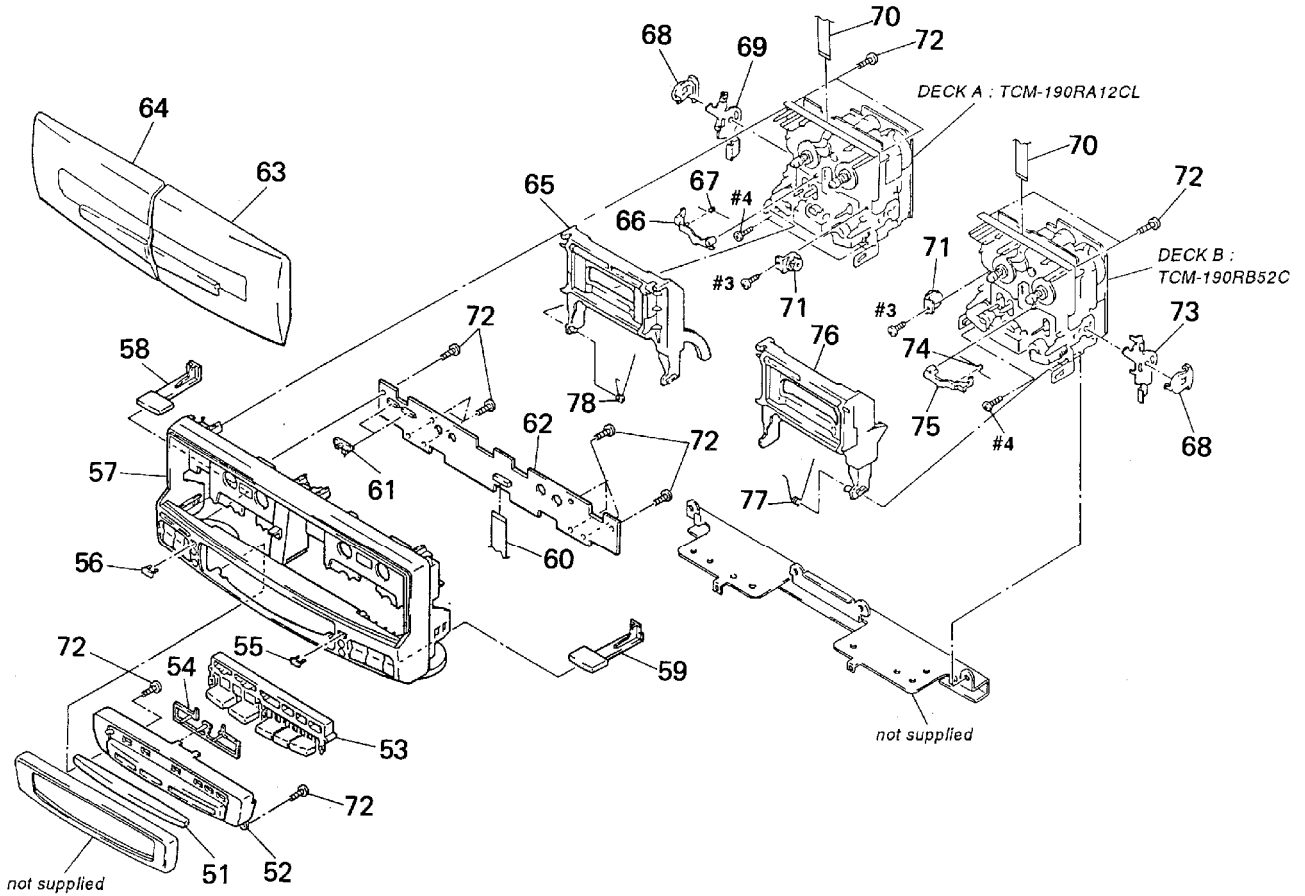

Ref.No.	Part No.	Description	Remark
51	3-919-567-01	WINDOW (DISPLAY)	
52	3-919-571-01	BASE, WINDOW	
53	3-919-566-01	BUTTON (REC)	
54	3-919-577-01	INDICATOR (REC)	
55	3-919-573-01	COVER (AZIMUTH B)	
56	3-919-572-01	COVER (AZIMUTH A)	
57	X-3369-489-1	PANEL ASSY, FRONT	
58	3-919-574-01	SLIDER (L)	
59	3-919-575-01	SLIDER (R)	
60	1-769-390-11	WIRE (FLAT TYPE) (17 CORE)	
61	3-919-576-01	KNOB (SLIDE)	
* 62	A-2007-302-A	TC PANEL BOARD, COMPLETE	
63	X-3369-491-1	LID (B) ASSY, CASSETTE	
64	X-3369-490-1	LID (A) ASSY, CASSETTE	

Ref.No.	Part No.	Description	Remark
65	X-3369-493-1	HOLDER (L) ASSY, CASSETTE	
66	3-354-955-01	LEVER (EJ SAFTY LEVER L)	
67	3-354-961-01	SPRING (EJ SAFTY SPRING L)	
68	3-354-957-01	JOINT (LOCK LEVER)	
* 69	3-354-953-01	LEVER (LOCK LEVER L)	
70	1-765-384-11	WIRE (FLAT TYPE) (7 CORE)	
71	3-354-963-01	DAMPER	
72	4-951-620-01	SCREW (2.6x8), +BVTP	
* 73	3-354-954-01	LEVER (LOCK LEVER R)	
74	3-354-962-01	SPRING (EJ SAFTY SPRING R)	
75	3-354-956-01	LEVER (EJ SAFTY LEVER R)	
76	X-3369-494-1	HOLDER (R) ASSY, CASSETTE	
77	4-959-231-01	SPRING (L), TORSION	
78	4-959-232-01	SPRING (R), TORSION	

5-3. MECHANISM SECTION-1

(DECK A : TCM-190RA12CL)
(DECK B : TCM-190RB52C)

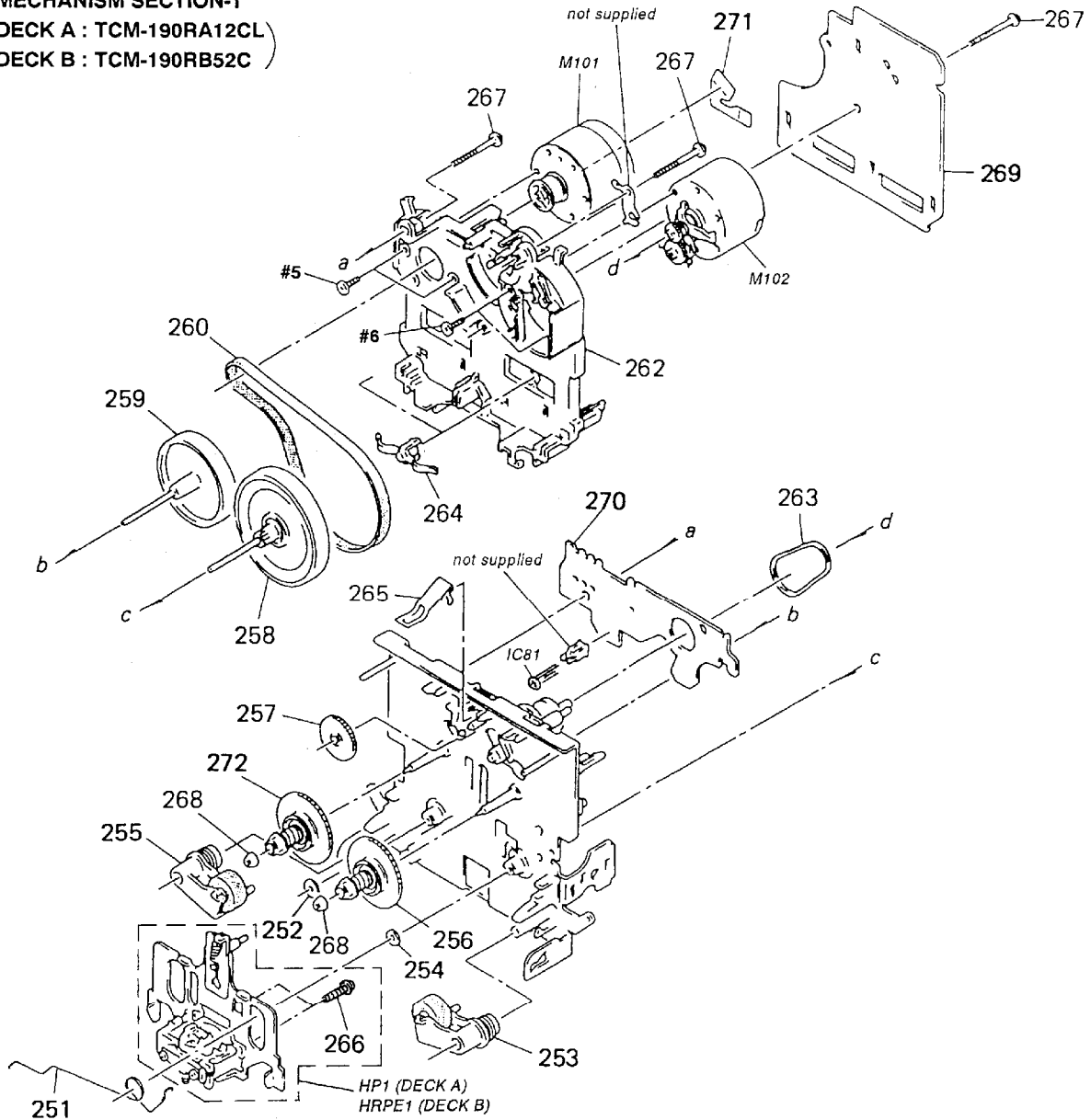

Ref.No.	Part No.	Description	Remark	Ref.No.	Part No.	Description	Remark
251	3-907-362-01	SPRING, TORSION		265	3-359-430-01	SPRING (CASSETTE RETAINER), LEAF	
252	3-356-714-01	WASHER		266	3-388-848-01	SCREW (P2×6) (B TIGHT)	
253	X-3366-047-1	LEVER (PINCH F) ASSY		267	3-359-414-01	SCREW (+PTPWH 2×23)	
254	3-356-713-01	WASHER		268	3-362-308-01	CAP (REEL)	
255	X-3366-048-1	LEVER (PINCH R) ASSY		* 269	A-2007-133-A	AUDIO BOARD, COMPLETE (DECK B)	
256	X-3366-971-1	TABLE ASSY (B), REEL (DECK A)		* 269	A-2007-266-A	AUDIO BOARD, COMPLETE (DECK A)	
256	X-3369-508-1	TABLE (C) ASSY, REEL (DECK B)		* 270	1-638-020-11	LEAF SW BOARD (DECK A) (DECK B)	
257	3-359-424-01	GEAR (REV GEAR)		271	1-638-983-11	PC BOARD, MOTOR FLEXIBLE	
258	X-3367-629-1	FLYWHEEL (FWD) ASSY		272	X-3366-970-1	TABLE ASSY, REEL	
259	X-3359-410-1	FLYWHEEL (REV) ASSY (DECK A)		HP1	A-2003-757-A	BASE ASSY, HEAD (PB) (DECK A)	
259	X-3367-630-1	FLYWHEEL (REV) ASSY (DECK B)		HRPE1	A-2003-930-A	BASE ASSY, HEAD (PB/REC/ERASE) (DECK B)	
260	3-359-417-01	BELT (FLAT), CAPSTAN		IC81	8-749-924-10	IC PHONT REFLECTOR NJL5165K-B(H1)	
262	3-359-436-11	BASE (THRUST RETAINER), FITTING		M101	X-3365-377-2	MOTOR ASSY (CAPSTAN)	
263	3-359-466-01	BELT (FR), SQUARE		M102	X-3363-501-2	MOTOR ASSY (REEL)	
264	3-575-321-00	RETAINER, THRUST, CAPSTAN					

5-4. MECHANISM SECTION-2

(DECK A : TCM-190RA12CL)
 (DECK B : TCM-190RB52C)

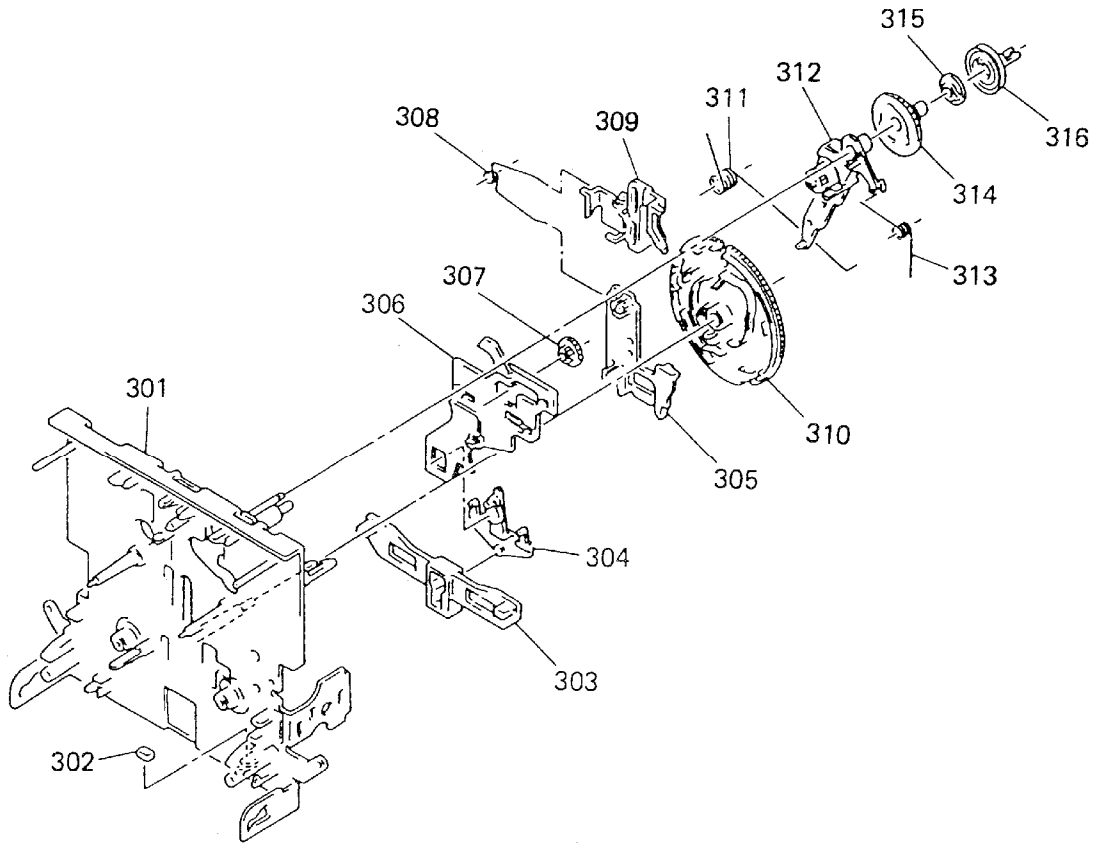

Ref.No.	Part No.	Description	Remark	Ref.No.	Part No.	Description	Remark
301	X-3359-415-1	CHASSIS ASSY, MECHANICAL		309	3-359-429-01	SLIDER (BRAKE PLATE) (DECK A)	
302	3-359-469-01	SPACER		309	3-359-429-11	SLIDER (BRAKE PLATE) (DECK B)	
303	3-359-425-01	SLIDER (REVERSE SLIDER)		310	3-359-420-01	GEAR (CAM GEAR)	
304	3-359-426-01	LEVER (REVERSE LEVER)		311	3-359-456-01	SPRING (TRIGGER SPRING), TORSION	
305	3-359-427-01	SLIDER (LEVERSE SLIDER)		312	X-3366-569-1	ARM ASSY, FR	
* 306	3-359-415-01	SLIDER (TRIGGER SLIDER) (DECK A)		313	3-924-185-11	SPRING (FR ARM), TORSION	
306	3-359-415-11	SLIDER (TRIGGER SLIDER) (DECK B)		314	3-359-419-11	GEAR (FR GEAR)	
307	3-359-448-01	GEAR (TRIGGER)		315	3-359-421-01	CLUTCH (REEL DISK)	
308	3-359-454-01	SPRING, TORSION		316	3-359-418-01	PULLEY (FR PULLEY)	

SECTION 6
ELECTRICAL PARTS LIST

AUDIO (DECK A)

AUDIO (DECK B)

NOTE :

- Due to standardization, replacements in the parts list may be different from the parts specified in the diagrams or the components used on the set.
- -XX, -X mean standardized parts, so they may have some difference from the original one.
- RESISTORS
All resistors are in ohms
METAL : Metal-film resistor
METAL OXIDE : Metal oxide-film resistor
F : nonflammable

- Items marked " * " are not stocked since they are seldom required for routine service. Some delay should be anticipated when ordering these items.
- SEMICONDUCTORS
In each case, u : μ , for example :
uA..... : μ A....., uPA..... : μ PA.....
uPB..... : μ PB....., uPC..... : μ PC.....
uPD..... : μ PD.....
- CAPACITORS
uF : μ F
- COILS
uH : μ H

The components identified by mark Δ or dotted line with mark Δ are critical for safety. Replace only with part number specified.

When indicating parts by reference number, please include the board.

Ref.No.	Part No.	Description	Remark		
*	A-2007-266-A	AUDIO BOARD, COMPLETE (DECK A) *****			
		< CAPACITOR >			
C11	1-163-131-00	CERAMIC CHIP	390PF	5%	50V
C12	1-136-157-00	FILM	0.022uF	5%	50V
C13	1-124-234-00	ELECT	22uF	20%	16V
C18	1-163-117-00	CERAMIC CHIP	100PF	5%	50V
C21	1-163-131-00	CERAMIC CHIP	390PF	5%	50V
C22	1-136-157-00	FILM	0.022uF	5%	50V
C23	1-124-234-00	ELECT	22uF	20%	16V
C28	1-163-117-00	CERAMIC CHIP	100PF	5%	50V
C31	1-124-234-00	ELECT	22uF	20%	16V
C32	1-124-234-00	ELECT	22uF	20%	16V
C72	1-124-499-11	ELECT, NONPOLAR	1uF	20%	50V
		< CONNECTOR >			
* CNJ31	1-580-782-11	CONNECTOR, BOARD TO BOARD			
CNJ72	1-764-902-11	CONNECTOR, FPC/FPC 4P			
		< CONNECTOR >			
* CNP32	1-580-772-11	PIN, CONNECTOR (PC BOARD) 4P			
* CNP71	1-564-719-11	PIN, CONNECTOR (SMALL TYPE) 3P			
		< IC >			
IC31	8-759-106-02	IC	uPC4570G2		
		< JUMPER RESISTOR >			
JW1	1-216-295-00	METAL CHIP	0	5%	1/10W
JW51	1-216-296-00	METAL CHIP	0	5%	1/8W
JW52	1-216-296-00	METAL CHIP	0	5%	1/8W
JW53	1-216-296-00	METAL CHIP	0	5%	1/8W
JW54	1-216-296-00	METAL CHIP	0	5%	1/8W

Ref.No.	Part No.	Description	Remark		
		< TRANSISTOR >			
Q71	8-729-216-22	TRANSISTOR	2SA1162-G		
		< RESISTOR >			
R11	1-216-099-00	METAL CHIP	120K	5%	1/10W
R12	1-216-025-91	METAL GLAZE	100	5%	1/10W
R13	1-216-100-00	METAL GLAZE	130K	5%	1/10W
R14	1-216-068-00	METAL CHIP	6.2K	5%	1/10W
R21	1-216-099-00	METAL CHIP	120K	5%	1/10W
R22	1-216-025-91	METAL GLAZE	100	5%	1/10W
R23	1-216-100-00	METAL GLAZE	130K	5%	1/10W
R24	1-216-068-00	METAL CHIP	6.2K	5%	1/10W
R31	1-216-033-00	METAL CHIP	220	5%	1/10W
R32	1-216-033-00	METAL CHIP	220	5%	1/10W
R71	1-216-082-00	METAL GLAZE	24K	5%	1/10W
R72	1-216-081-00	METAL CHIP	22K	5%	1/10W
R73	1-216-089-00	METAL CHIP	47K	5%	1/10W
R74	1-216-089-00	METAL CHIP	47K	5%	1/10W
		< VARIABLE RESISTOR >			
RV11	1-241-761-11	RES, ADJ, CARBON 1K (PLAY BACK LEVEL			L-CH)
RV21	1-241-761-11	RES, ADJ, CARBON 1K (PLAY BACK LEVEL			R-CH)
RV71	1-241-630-11	RES, ADJ, CARBON 10K (TAPE SPEED NORMAL)			
RV72	1-241-630-11	RES, ADJ, CARBON 10K (TAPE SPEED HIGH)			

*	A-2007-133-A	AUDIO BOARD, COMPLETE (DECK B) *****			
		< CAPACITOR >			
C11	1-163-131-00	CERAMIC CHIP	390PF	5%	50V
C12	1-163-117-00	CERAMIC CHIP	100PF	5%	50V

AUDIO (DECK B)

Ref.No.	Part No.	Description	Remark			Ref.No.	Part No.	Description	Remark		
C13	1-136-153-00	FILM	0.01uF	5%	50V	JW18	1-216-296-00	METAL CHIP	0	5%	1/8W
C14	1-126-177-11	ELECT	100uF	20%	10V	JW19	1-216-296-00	METAL CHIP	0	5%	1/8W
C15	1-124-234-00	ELECT	22uF	20%	16V	JW20	1-216-296-00	METAL CHIP	0	5%	1/8W
C16	1-136-434-11	FILM	120PF	5%	630V	JW21	1-216-296-00	METAL CHIP	0	5%	1/8W
C17	1-164-080-11	CERAMIC	390PF	10%	50V	JW22	1-216-296-00	METAL CHIP	0	5%	1/8W
C18	1-163-103-00	CERAMIC CHIP	27PF	5%	50V	JW23	1-216-296-00	METAL CHIP	0	5%	1/8W
C21	1-163-131-00	CERAMIC CHIP	390PF	5%	50V	JW24	1-216-296-00	METAL CHIP	0	5%	1/8W
C22	1-163-117-00	CERAMIC CHIP	100PF	5%	50V	JW25	1-216-296-00	METAL CHIP	0	5%	1/8W
C23	1-136-153-00	FILM	0.01uF	5%	50V	JW26	1-216-296-00	METAL CHIP	0	5%	1/8W
C24	1-126-177-11	ELECT	100uF	20%	10V	JW27	1-216-296-00	METAL CHIP	0	5%	1/8W
C25	1-124-234-00	ELECT	22uF	20%	16V	< COIL >					
C26	1-136-434-11	FILM	120PF	5%	630V	L11	1-410-780-11	INDUCTOR	27mH		
C27	1-164-080-11	CERAMIC	390PF	10%	50V	L21	1-410-780-11	INDUCTOR	27mH		
C28	1-163-103-00	CERAMIC CHIP	27PF	5%	50V	< TRANSISTOR >					
C31	1-124-234-00	ELECT	22uF	20%	16V	Q51	8-729-111-29	TRANSISTOR	2SD1616A-K		
C32	1-124-234-00	ELECT	22uF	20%	16V	Q52	8-729-111-29	TRANSISTOR	2SD1616A-K		
C33	1-124-234-00	ELECT	22uF	20%	16V	Q53	8-729-111-29	TRANSISTOR	2SD1616A-K		
C51	1-163-019-00	CERAMIC CHIP	0.0068uF	10%	50V	Q71	8-729-216-22	TRANSISTOR	2SA1162-G		
C52	1-163-019-00	CERAMIC CHIP	0.0068uF	10%	50V	< RESISTOR >					
C53	1-163-023-00	CERAMIC CHIP	0.015uF	5%	50V	R11	1-216-099-00	METAL CHIP	120K	5%	1/10W
C54	1-136-601-11	FILM	0.01uF	5%	630V	R12	1-216-033-00	METAL CHIP	220	5%	1/10W
C56	1-164-505-11	CERAMIC CHIP	2.2uF		16V	R13	1-216-081-00	METAL CHIP	22K	5%	1/10W
C57	1-164-346-11	CERAMIC CHIP	1uF		16V	R14	1-216-075-00	METAL CHIP	12K	5%	1/10W
C58	1-164-232-11	CERAMIC CHIP	0.01uF		50V	R15	1-216-107-00	METAL CHIP	270K	5%	1/10W
C72	1-109-889-11	ELECT	1uF	20%	50V	△R16	1-249-430-11	CARBON	12K	5%	1/4W F
< CONNECTOR >						R21	1-216-099-00	METAL CHIP	120K	5%	1/10W
* CNJ31	1-580-782-11	CONNECTOR, BOARD TO BOARD				R22	1-216-033-00	METAL CHIP	220	5%	1/10W
* CNJ33	1-580-782-11	CONNECTOR, BOARD TO BOARD				R23	1-216-081-00	METAL CHIP	22K	5%	1/10W
CNJ72	1-764-902-11	CONNECTOR, FFC/FPC 4P				R24	1-216-075-00	METAL CHIP	12K	5%	1/10W
< CONNECTOR >						R25	1-216-107-00	METAL CHIP	270K	5%	1/10W
* CNP32	1-580-781-11	PIN, CONNECTOR (PC BOARD) 7P				△R26	1-249-430-11	CARBON	12K	5%	1/4W F
* CNP71	1-564-719-11	PIN, CONNECTOR (SMALL TYPE) 3P				R31	1-216-033-00	METAL CHIP	220	5%	1/10W
< IC >						R32	1-216-033-00	METAL CHIP	220	5%	1/10W
IC31	8-759-249-21	IC uPC1330AGR				R33	1-216-073-00	METAL CHIP	10K	5%	1/10W
IC32	8-759-106-02	IC uPC4570G2				△R41	1-249-393-11	CARBON	10	5%	1/4W F
< JUMPER RESISTOR >						△R42	1-249-393-11	CARBON	10	5%	1/4W F
JW1	1-216-295-00	METAL CHIP	0	5%	1/10W	R51	1-216-689-11	METAL CHIP	39K	0.5%	1/10W
JW2	1-216-295-00	METAL CHIP	0	5%	1/10W	R52	1-216-689-11	METAL CHIP	39K	0.5%	1/10W
JW11	1-216-296-00	METAL CHIP	0	5%	1/8W	R53	1-216-073-00	METAL CHIP	10K	5%	1/10W
JW12	1-216-296-00	METAL CHIP	0	5%	1/8W	R54	1-216-309-00	METAL CHIP	5.6	5%	1/10W
JW13	1-216-296-00	METAL CHIP	0	5%	1/8W	R55	1-216-309-00	METAL CHIP	5.6	5%	1/10W
JW14	1-216-296-00	METAL CHIP	0	5%	1/8W	R56	1-216-298-00	METAL CHIP	2.2	5%	1/10W
JW15	1-216-296-00	METAL CHIP	0	5%	1/8W	R71	1-216-082-00	METAL GLAZE	24K	5%	1/10W
JW16	1-216-296-00	METAL CHIP	0	5%	1/8W	R72	1-216-081-00	METAL CHIP	22K	5%	1/10W
JW17	1-216-296-00	METAL CHIP	0	5%	1/8W	R73	1-216-089-00	METAL CHIP	47K	5%	1/10W
						R74	1-216-089-00	METAL CHIP	47K	5%	1/10W

The components identified by mark Δ or dotted line with mark Δ are critical for safety. Replace only with part number specified.

AUDIO (DECK B)

LEAF SW (DECK A)

LEAF SW (DECK B)

TC MAIN

Ref. No.	Part No.	Description	Remark
< VARIABLE RESISTOR >			
RV11	1-241-761-11	RES, ADJ, CARBON 1K (PLAY BACK LEVEL L-CH)	
RV12	1-238-551-11	RES, ADJ, CARBON 220K (REC BIAS L-CH)	
RV21	1-241-761-11	RES, ADJ, CARBON 1K (PLAY BACK LEVEL R-CH)	
RV22	1-238-551-11	RES, ADJ, CARBON 220K (REC BIAS R-CH)	
RV71	1-241-630-11	RES, ADJ, CARBON 10K (TAPE SPEED NORMAL)	
RV72	1-241-630-11	RES, ADJ, CARBON 10K (TAPE SPEED HIGH)	
< TRANSFORMER >			
T51	1-423-980-11	TRANSFORMER, BIAS OSCILLATION	

*	1-638-020-11	LEAF SW BOARD (DECK A)	

< CONNECTOR >			
* CNP81	1-568-850-11	SOCKET, CONNECTOR 7P	
< IC >			
IC81	8-749-924-10	IC PHONT REFLECTOR NJL5165K-B(H1)	
< RESISTOR >			
R84	1-249-417-11	CARBON 1K 5% 1/4W	
R85	1-249-408-11	CARBON 180 5% 1/4W	
< SWITCH >			
S81	1-571-958-11	SWITCH, PUSH (1 KEY) (STOP DET)	
S82	1-571-281-21	SWITCH, LEAF (70EQ)	
S86	1-571-281-21	SWITCH, LEAF (HALF)	

*	1-638-020-11	LEAF SW BOARD (DECK B)	

< CONNECTOR >			
* CNP81	1-568-850-11	SOCKET, CONNECTOR 7P	
< IC >			
IC81	8-749-924-10	IC PHONT REFLECTOR NJL5165K-B(H1)	
< RESISTOR >			
R81	1-249-414-11	CARBON 560 5% 1/4W	
R82	1-247-818-11	CARBON 300 5% 1/4W	
R83	1-247-834-11	CARBON 1.3K 5% 1/4W	
R84	1-249-417-11	CARBON 1K 5% 1/4W	
R85	1-249-408-11	CARBON 180 5% 1/4W	

Ref. No.	Part No.	Description	Remark
< SWITCH >			
S81	1-571-958-11	SWITCH, PUSH (1 KEY) (STOP DET)	
S82	1-571-281-21	SWITCH, LEAF (70EQ)	
S83	1-571-281-21	SWITCH, LEAF (MFTAL.)	
S84	1-571-281-21	SWITCH, LEAF (ERASE PROOF) (SIDE A)	
S85	1-571-281-21	SWITCH, LEAF (ERASE PROOF) (SIDE B)	
S86	1-571-281-21	SWITCH, LEAF (HALF)	

*	A-2007-301-A	TC MAIN BOARD, COMPLETE	

< CAPACITOR >			
C104	1-130-475-00	MYLAR 0.0022uF 5% 50V	
C105	1-130-475-00	MYLAR 0.0022uF 5% 50V	
C106	1-124-925-11	ELECT 2.2uF 20% 100V	
C107	1-136-174-00	FILM 0.56uF 5% 50V	
C108	1-136-171-00	FILM 0.33uF 5% 50V	
C109	1-124-925-11	ELECT 2.2uF 20% 100V	
C110	1-124-925-11	ELECT 2.2uF 20% 100V	
C114	1-124-907-11	ELECT 10uF 20% 50V	
C115	1-124-443-00	ELECT 100uF 20% 10V	
C116	1-162-282-31	CERAMIC 100PF 10% 50V	
C117	1-124-925-11	ELECT 2.2uF 20% 100V	
C119	1-124-902-00	ELECT 0.47uF 20% 50V	
C120	1-124-927-11	ELECT 4.7uF 20% 100V	
C130	1-162-282-31	CERAMIC 100PF 10% 50V	
C131	1-162-282-31	CERAMIC 100PF 10% 50V	
C132	1-124-903-11	ELECT 1uF 20% 50V	
C133	1-162-286-21	CERAMIC 220PF 10% 50V	
C204	1-130-475-00	MYLAR 0.0022uF 5% 50V	
C205	1-130-475-00	MYLAR 0.0022uF 5% 50V	
C206	1-124-925-11	ELECT 2.2uF 20% 100V	
C207	1-136-174-00	FILM 0.56uF 5% 50V	
C208	1-136-171-00	FILM 0.33uF 5% 50V	
C209	1-124-925-11	ELECT 2.2uF 20% 100V	
C210	1-124-925-11	ELECT 2.2uF 20% 100V	
C214	1-124-907-11	ELECT 10uF 20% 50V	
C215	1-124-443-00	ELECT 100uF 20% 10V	
C216	1-162-282-31	CERAMIC 100PF 10% 50V	
C217	1-124-925-11	ELECT 2.2uF 20% 100V	
C219	1-124-902-00	ELECT 0.47uF 20% 50V	
C220	1-124-927-11	ELECT 4.7uF 20% 100V	
C230	1-162-282-31	CERAMIC 100PF 10% 50V	
C231	1-162-282-31	CERAMIC 100PF 10% 50V	
C232	1-124-903-11	ELECT 1uF 20% 50V	
C233	1-162-286-21	CERAMIC 220PF 10% 50V	
C502	1-128-489-11	ELECT 3300uF 20% 16V	

TC MAIN

Ref. No.	Part No.	Description	Remark	Ref. No.	Part No.	Description	Remark
C504	1-128-489-11	ELECT	3300uF 20% 16V	CN603	1-695-330-31	PIN, CONNECTOR (PC BOARD) 7P	
C518	1-126-927-11	ELECT	2200uF 20% 10V	* CN604	1-691-916-11	CONNECTOR, BOARD TO BOARD	
C519	1-126-927-11	ELECT	2200uF 20% 10V	* CN605	1-691-916-11	CONNECTOR, BOARD TO BOARD	
C529	1-136-157-00	FILM	0.022uF 5% 50V	CN608	1-770-166-11	CONNECTOR, FFC/FPC 17P	
C530	1-136-157-00	FILM	0.022uF 5% 50V	CN609	1-770-158-21	SOCKET, CONNECTOR 7P (SYSTEM CONTROL)	
C533	1-136-157-00	FILM	0.022uF 5% 50V	* CN610	1-565-561-11	PIN, CONNECTOR 3P (AU BUS)	
C534	1-136-157-00	FILM	0.022uF 5% 50V	< DIODE >			
C535	1-124-360-00	ELECT	1000uF 20% 16V	D508	8-719-200-02	DIODE 10E2	
C536	1-124-360-00	ELECT	1000uF 20% 16V	D509	8-719-200-02	DIODE 10E2	
C537	1-124-472-11	ELECT	470uF 20% 10V	D510	8-719-200-02	DIODE 10E2	
C538	1-124-472-11	ELECT	470uF 20% 10V	D511	8-719-200-02	DIODE 10E2	
C540	1-124-473-11	ELECT	1000uF 20% 10V	D512	8-719-200-02	DIODE 10E2	
C550	1-162-282-31	CERAMIC	100PF 10% 50V	D513	8-719-200-02	DIODE 10E2	
C601	1-124-443-00	ELECT	100uF 20% 10V	D519	8-719-200-02	DIODE 10E2	
C602	1-164-159-11	CERAMIC	0.1uF 50V	D522	8-719-200-02	DIODE 10E2	
C604	1-164-159-11	CERAMIC	0.1uF 50V	D523	8-719-987-63	DIODE 1N4148M	
C605	1-124-902-00	ELECT	0.47uF 20% 50V	D524	8-719-987-63	DIODE 1N4148M	
C606	1-124-480-11	ELECT	470uF 20% 25V	D525	8-719-200-02	DIODE 10E2	
C607	1-124-480-11	ELECT	470uF 20% 25V	D526	8-719-200-02	DIODE 10E2	
C608	1-124-480-11	ELECT	470uF 20% 25V	D601	8-719-987-63	DIODE 1N4148M	
C609	1-124-902-00	ELECT	0.47uF 20% 50V	D602	8-719-987-63	DIODE 1N4148M	
C610	1-124-472-11	ELECT	470uF 20% 10V	D603	8-719-987-63	DIODE 1N4148M	
C611	1-162-290-31	CERAMIC	470PF 10% 50V	D604	8-719-987-63	DIODE 1N4148M	
C612	1-124-472-11	ELECT	470uF 20% 10V	D605	8-719-200-02	DIODE 10E2	
C613	1-162-290-31	CERAMIC	470PF 10% 50V	D606	8-719-200-02	DIODE 10E2	
C614	1-164-159-11	CERAMIC	0.1uF 50V	D607	8-719-987-63	DIODE 1N4148M	
C615	1-164-159-11	CERAMIC	0.1uF 50V	D608	8-719-987-63	DIODE 1N4148M	
C616	1-124-910-11	ELECT	47uF 20% 50V	D609	8-719-987-63	DIODE 1N4148M	
C617	1-164-159-11	CERAMIC	0.1uF 50V	D610	8-719-200-02	DIODE 10E2	
C620	1-124-907-11	ELECT	10uF 20% 50V	D611	8-719-987-63	DIODE 1N4148M	
C621	1-124-907-11	ELECT	10uF 20% 50V	D620	8-719-010-05	DIODE UZ-2.0BSB	
C622	1-124-477-11	ELECT	47uF 20% 25V	< IC >			
C623	1-124-477-11	ELECT	47uF 20% 25V	IC101	8-752-058-57	IC CXA1599Q	
C630	1-124-927-11	ELECT	4.7uF 20% 100V	IC102	8-759-939-73	IC BA3308	
C631	1-124-903-11	ELECT	1uF 20% 50V	IC103	8-752-059-55	IC CXA1331S	
C636	1-124-916-11	ELECT	22uF 20% 63V	IC104	8-759-337-73	IC M38123M4-118FP	
C641	1-124-927-11	ELECT	4.7uF 20% 100V	IC502	8-759-231-53	IC TA7805S	
C642	1-124-902-00	ELECT	0.47uF 20% 50V	IC503	8-759-604-86	IC M5F7807	
C645	1-124-907-11	ELECT	10uF 20% 50V	IC504	8-759-604-90	IC M5F7907L	
C646	1-124-925-11	ELECT	2.2uF 20% 100V	IC505	8-759-604-86	IC M5F7807	
C649	1-124-907-11	ELECT	10uF 20% 50V	IC506	8-759-604-90	IC M5F7907L	
C650	1-124-916-11	ELECT	22uF 20% 63V	IC602	8-759-510-54	IC PST572D	
C651	1-124-443-00	ELECT	100uF 20% 10V	IC603	8-759-266-35	IC TA8242AK	
C800	1-162-282-31	CERAMIC	100PF 10% 50V	IC6004	8-759-000-48	IC MC14052BCP	
C6035	1-162-294-31	CERAMIC	0.001uF 10% 50V				
< CONNECTOR >							
CN601	1-695-330-31	PIN, CONNECTOR (PC BOARD) 7P					
* CN602	1-691-916-11	CONNECTOR, BOARD TO BOARD					

TC MAIN

Ref. No.	Part No.	Description	Remark	Ref. No.	Part No.	Description	Remark
		< COIL >					
L101	1-410-470-11	INDUCTOR 10uH		R120	1-247-807-31	CARBON 100 5%	1/4W
L102	1-410-470-11	INDUCTOR 10uH		R121	1-247-807-31	CARBON 100 5%	1/4W
L601	1-410-482-31	INDUCTOR 100uH		R122	1-249-422-11	CARBON 2.7K 5%	1/4W
L6002	1-410-470-11	INDUCTOR 10uH		R206	1-247-832-11	CARBON 1.1K 5%	1/4W
		< JACK >		R207	1-247-864-11	CARBON 24K 5%	1/4W
PJ101	1-695-188-31	JACK, PIN 4P (TAPE-1)		R208	1-249-414-11	CARBON 560 5%	1/4W
		< TRANSISTOR >		R209	1-249-429-11	CARBON 10K 5%	1/4W
Q101	8-729-107-85	TRANSISTOR 2SC3623A-K		R210	1-249-427-11	CARBON 6.8K 5%	1/4W
Q122	8-729-900-89	TRANSISTOR DTC144ES		R211	1-249-427-11	CARBON 6.8K 5%	1/4W
Q201	8-729-107-85	TRANSISTOR 2SC3623A-K		R212	1-247-832-11	CARBON 1.1K 5%	1/4W
Q222	8-729-900-89	TRANSISTOR DTC144ES		R213	1-249-429-11	CARBON 10K 5%	1/4W
Q603	8-729-801-93	TRANSISTOR 2SD1387		R214	1-249-421-11	CARBON 2.2K 5%	1/4W
Q604	8-729-801-93	TRANSISTOR 2SD1387		R215	1-247-887-00	CARBON 220K 5%	1/4W
Q605	8-729-900-80	TRANSISTOR DTC114ES		R216	1-249-437-11	CARBON 47K 5%	1/4W
Q607	8-729-900-89	TRANSISTOR DTC144ES		R217	1-249-415-11	CARBON 680 5%	1/4W
Q608	8-729-900-89	TRANSISTOR DTC144ES		R218	1-249-439-11	CARBON 68K 5%	1/4W
Q609	8-729-900-89	TRANSISTOR DTC144ES		R219	1-249-415-11	CARBON 680 5%	1/4W
Q611	8-729-107-85	TRANSISTOR 2SC3623A-K		R220	1-247-807-31	CARBON 100 5%	1/4W
Q612	8-729-119-76	TRANSISTOR 2SA1175-HFE		R221	1-247-807-31	CARBON 100 5%	1/4W
Q613	8-729-900-65	TRANSISTOR DTA144ES		R222	1-249-422-11	CARBON 2.7K 5%	1/4W
Q614	8-729-900-89	TRANSISTOR DTC144ES		R504	1-247-807-31	CARBON 100 5%	1/4W
Q620	8-729-900-89	TRANSISTOR DTC144ES		R505	1-249-429-11	CARBON 10K 5%	1/4W
Q621	8-729-900-65	TRANSISTOR DTA144ES		R506	1-249-393-11	CARBON 10 5%	1/4W
Q627	8-729-900-89	TRANSISTOR DTC144ES		R601	1-247-807-31	CARBON 100 5%	1/4W
Q630	8-729-900-61	TRANSISTOR DTA114ES		R602	1-247-807-31	CARBON 100 5%	1/4W
Q802	8-729-900-80	TRANSISTOR DTC114ES		R606	1-249-435-11	CARBON 33K 5%	1/4W
Q803	8-729-900-80	TRANSISTOR DTC114ES		R607	1-247-807-31	CARBON 100 5%	1/4W
Q804	8-729-900-80	TRANSISTOR DTC114ES		R615	1-247-807-31	CARBON 100 5%	1/4W
Q805	8-729-900-80	TRANSISTOR DTC114ES		R616	1-247-863-91	CARBON 22K 5%	1/4W
		< RESISTOR >		R620	1-249-441-11	CARBON 100K 5%	1/4W
R106	1-247-832-11	CARBON 1.1K 5%	1/4W	R621	1-249-417-11	CARBON 1K 5%	1/4W
R107	1-247-864-11	CARBON 24K 5%	1/4W	R622	1-249-421-11	CARBON 2.2K 5%	1/4W
R108	1-249-414-11	CARBON 560 5%	1/4W	R623	1-249-421-11	CARBON 2.2K 5%	1/4W
R109	1-249-429-11	CARBON 10K 5%	1/4W	R624	1-249-434-11	CARBON 27K 5%	1/4W
R110	1-249-427-11	CARBON 6.8K 5%	1/4W	R625	1-249-421-11	CARBON 2.2K 5%	1/4W
R111	1-249-427-11	CARBON 6.8K 5%	1/4W	R626	1-249-421-11	CARBON 2.2K 5%	1/4W
R112	1-247-832-11	CARBON 1.1K 5%	1/4W	R627	1-249-421-11	CARBON 2.2K 5%	1/4W
R113	1-249-429-11	CARBON 10K 5%	1/4W	R628	1-249-434-11	CARBON 27K 5%	1/4W
R114	1-249-421-11	CARBON 2.2K 5%	1/4W	R629	1-249-421-11	CARBON 2.2K 5%	1/4W
R115	1-247-887-00	CARBON 220K 5%	1/4W	R630	1-249-429-11	CARBON 10K 5%	1/4W
R116	1-249-437-11	CARBON 47K 5%	1/4W	R631	1-249-421-11	CARBON 2.2K 5%	1/4W
R117	1-249-415-11	CARBON 680 5%	1/4W	R632	1-249-429-11	CARBON 10K 5%	1/4W
R118	1-249-439-11	CARBON 68K 5%	1/4W	R633	1-247-807-31	CARBON 100 5%	1/4W
R119	1-249-415-11	CARBON 680 5%	1/4W	R634	1-247-807-31	CARBON 100 5%	1/4W
				R637	1-249-414-11	CARBON 560 5%	1/4W
				R640	1-249-428-11	CARBON 8.2K 5%	1/4W
				R641	1-249-409-11	CARBON 220 5%	1/4W
				R642	1-249-421-11	CARBON 2.2K 5%	1/4W
				R643	1-247-807-31	CARBON 100 5%	1/4W

TC MAIN

TC PANEL

Ref.No.	Part No.	Description	Remark
R644	1-247-807-31	CARBON 100 5%	1/4W
R648	1-249-437-11	CARBON 47K 5%	1/4W
R649	1-249-437-11	CARBON 47K 5%	1/4W
R650	1-249-437-11	CARBON 47K 5%	1/4W
R656	1-249-393-11	CARBON 10 5%	1/4W
R660	1-249-417-11	CARBON 1K 5%	1/4W
R661	1-249-434-11	CARBON 27K 5%	1/4W
R670	1-247-863-91	CARBON 22K 5%	1/4W
R673	1-249-429-11	CARBON 10K 5%	1/4W
R674	1-247-860-11	CARBON 16K 5%	1/4W
R675	1-249-429-11	CARBON 10K 5%	1/4W
R676	1-249-434-11	CARBON 27K 5%	1/4W
R677	1-247-807-31	CARBON 100 5%	1/4W
R678	1-247-807-31	CARBON 100 5%	1/4W
R679	1-247-807-31	CARBON 100 5%	1/4W
R680	1-249-441-11	CARBON 100K 5%	1/4W
R681	1-249-429-11	CARBON 10K 5%	1/4W
R682	1-249-429-11	CARBON 10K 5%	1/4W
R683	1-249-429-11	CARBON 10K 5%	1/4W
R684	1-249-413-11	CARBON 470 5%	1/4W
R685	1-249-429-11	CARBON 10K 5%	1/4W
R686	1-249-429-11	CARBON 10K 5%	1/4W
R687	1-249-417-11	CARBON 1K 5%	1/4W
R689	1-247-872-11	CARBON 51K 5%	1/4W
R690	1-249-429-11	CARBON 10K 5%	1/4W
R691	1-249-425-11	CARBON 4.7K 5%	1/4W
R693	1-247-863-91	CARBON 22K 5%	1/4W
R694	1-247-863-91	CARBON 22K 5%	1/4W
R695	1-249-421-11	CARBON 2.2K 5%	1/4W
R696	1-249-421-11	CARBON 2.2K 5%	1/4W
R700	1-247-903-00	CARBON 1M 5%	1/4W
R701	1-249-429-11	CARBON 10K 5%	1/4W
R702	1-249-437-11	CARBON 47K 5%	1/4W
R801	1-249-417-11	CARBON 1K 5%	1/4W
R802	1-247-807-31	CARBON 100 5%	1/4W
R803	1-247-807-31	CARBON 100 5%	1/4W
R804	1-247-807-31	CARBON 100 5%	1/4W
R805	1-247-807-31	CARBON 100 5%	1/4W
R807	1-247-863-91	CARBON 22K 5%	1/4W
R808	1-249-429-11	CARBON 10K 5%	1/4W
R809	1-249-429-11	CARBON 10K 5%	1/4W
R810	1-249-429-11	CARBON 10K 5%	1/4W
R813	1-249-411-11	CARBON 330 5%	1/4W
R814	1-249-411-11	CARBON 330 5%	1/4W
R815	1-249-411-11	CARBON 330 5%	1/4W
R816	1-249-411-11	CARBON 330 5%	1/4W
R817	1-249-411-11	CARBON 330 5%	1/4W
R818	1-249-435-11	CARBON 33K 5%	1/4W
R819	1-249-393-11	CARBON 10 5%	1/4W

Ref.No.	Part No.	Description	Remark
R820	1-249-417-11	CARBON 1K 5%	1/4W
R821	1-249-417-11	CARBON 1K 5%	1/4W
R822	1-249-417-11	CARBON 1K 5%	1/4W
R823	1-249-425-11	CARBON 4.7K 5%	1/4W
R6070	1-249-421-11	CARBON 2.2K 5%	1/4W
R6071	1-249-421-11	CARBON 2.2K 5%	1/4W
		< VARIABLE RESISTOR >	
RV101	1-238-600-11	RES, ADJ, CARBON 10K	
RV201	1-238-600-11	RES, ADJ, CARBON 10K	
		< VIBRATOR >	
X601	1-577-358-21	VIBRATOR, CERAMIC	

*	A-2007-302-A	TC PANEL BOARD, COMPLETE	

		< CONNECTOR >	
CN900	1-770-169-11	CONNECTOR, FPC/FPC 17P	
		< DIODE >	
D900	8-719-046-42	LED SEL5421E-TH8F (DECK A >)	
D901	8-719-046-42	LED SEL5421E-TH8F (<DECK A)	
D902	8-719-046-42	LED SEL5421E-TH8F (DECK B >)	
D903	8-719-046-42	LED SEL5421E-TH8F (<DECK B)	
D906	8-719-046-44	LED SEL5221S-TP15 (CD SYNCHRO)	
D907	8-719-046-44	LED SEL5221S-TP15 (HIGHT)	
D908	8-719-046-44	LED SEL5221S-TP15 (NORMAL)	
D909	8-719-046-36	LED SEL5921A-TH15 (II)	
D910	8-719-046-44	LED SEL5221S-TP15 (REC)	
		< RESISTOR >	
R900	1-249-418-11	CARBON 1.2K 5%	1/4W
R901	1-249-420-11	CARBON 1.8K 5%	1/4W
R902	1-249-422-11	CARBON 2.7K 5%	1/4W
R903	1-249-424-11	CARBON 3.9K 5%	1/4W
R904	1-249-427-11	CARBON 6.8K 5%	1/4W
R905	1-249-418-11	CARBON 1.2K 5%	1/4W
R906	1-249-420-11	CARBON 1.8K 5%	1/4W
R907	1-249-422-11	CARBON 2.7K 5%	1/4W
R908	1-249-424-11	CARBON 3.9K 5%	1/4W
R909	1-249-427-11	CARBON 6.8K 5%	1/4W
R910	1-249-431-11	CARBON 15K 5%	1/4W
R911	1-249-437-11	CARBON 47K 5%	1/4W
R914	1-249-426-11	CARBON 5.6K 5%	1/4W
R915	1-249-434-11	CARBON 27K 5%	1/4W
R916	1-249-425-11	CARBON 4.7K 5%	1/4W

TC PANEL

Ref. No.	Part No.	Description	Remark
< SWITCH >			
S900	1-762-205-11	SWITCH, SLIDE (DIRECTION MODE)	
S901	1-762-205-11	SWITCH, SLIDE (DOLBY NR)	
S902	1-554-303-21	SWITCH, TACTILE (□)	
S903	1-554-303-21	SWITCH, TACTILE (>)	
S904	1-554-303-21	SWITCH, TACTILE (<)	
S905	1-554-303-21	SWITCH, TACTILE (PAUSE)	
S906	1-554-303-21	SWITCH, TACTILE (AMS/◀◀)	
S907	1-554-303-21	SWITCH, TACTILE (AMS/▶▶)	
S908	1-554-303-21	SWITCH, TACTILE (□)	
S909	1-554-303-21	SWITCH, TACTILE (>)	
S910	1-554-303-21	SWITCH, TACTILE (<)	
S911	1-554-303-21	SWITCH, TACTILE (AMS/◀◀)	
S912	1-554-303-21	SWITCH, TACTILE (AMS/▶▶)	
S913	1-554-303-21	SWITCH, TACTILE (● REC)	
S915	1-554-303-21	SWITCH, TACTILE (DUBBING MODE)	
S916	1-554-303-21	SWITCH, TACTILE (CD SYNCHRO)	
S917	1-554-303-21	SWITCH, TACTILE (● REC MUTE)	

MISCELLANEOUS			

60	1-769-390-11	WIRE (FLAT TYPE) (17 CORE)	
70	1-765-384-11	WIRE (FLAT TYPE) (7 CORE)	
271	1-638-983-11	PC BOARD, MOTOR FLEXIBLE	
HP1	A-2003-757-A	BASE ASSY, HEAD (PB) (DECK A)	
HRPE1	A-2003-930-A	BASE ASSY, HEAD (PB/REC/ERASE) (DECK B)	
IC81	8-749-924-10	IC PHONT REFLECTOR NJL5165K-B(H1)	
M101	X-3365-377-2	MOTOR ASSY (CAPSTAN)	
M102	X-3363-501-2	MOTOR ASSY (REEL)	

HARDWARE LIST			

#1	7-685-646-79	SCREW +BVTP 3×8 TYPE2 N-S	
#2	7-685-871-01	SCREW +BVTT 3×6 (S)	
#3	7-621-770-67	SCREW +PTT 2.6×6 (S)	
#4	7-685-862-04	SCREW +BVTT 2.6×6 (S)	
#5	7-621-775-00	SCREW +B 2.6×3	
#6	7-627-556-08	SCREW +P 2.6×2.8	

TC-EX5

9-960-061-11

Sony Corporation
Consumer A&V Products Company
Home A&V Products Div.

— 34 —

English
95B0286-1
Printed in Japan
© 1995.2
Published by Home A&V Products Div.
Quality Engineering Dept.